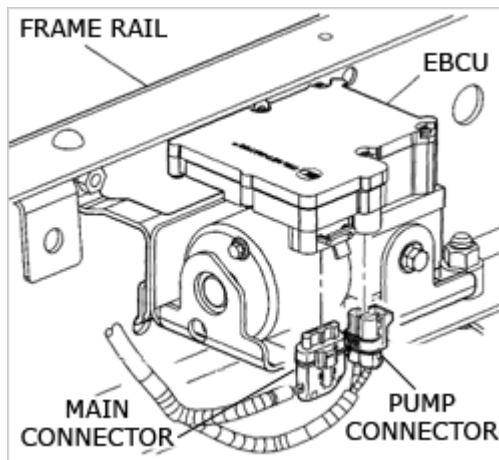

1999-2008

Note: The 1999-2008 Tahoe uses more than one type of ABS module. We can only rebuild the Kelsey Hayes 325 module (on right). The Series 30 is similar, but has a third connector as shown. Both the Series 30 and 310 are unrepairable and must be replaced.

On most Chevy trucks, the ABS module is mounted to the left frame rail under the driver's seat (see diagram below).

**Pulling the ABS Fuse (Only necessary if ABS pump is running continuously)**

Locate and pull the ABS pump fuse located in the power distribution center under the hood near the battery (see photo below). It is a 60 amp fuse in most instances and should be clearly labeled "ABS". Removing the fuse should stop the pump motor. If you can't find the proper fuse, remove the positive (+) battery connection.





Disconnecting the Module

1) To disconnect the rectangular plug, insert a screwdriver under the red plastic locking clip. The EBCM will of course be under your vehicle when doing this.



2) Pry the red locking clip into the down position as shown.

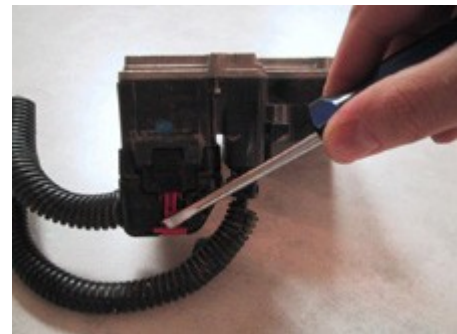

Removal Procedure

1. Find a level place to raise the vehicle.
2. Set the parking brake firmly.
3. Put an automatic transmission shift lever in PARK or shift a manual transmission to FIRST or REVERSE gear.
4. For 4-wheel drive vehicles, be sure the transfer case is in a drive gear, not neutral.
5. Turn off the engine.
6. Place wheel blocks behind the rear wheels.
7. Use jack stands to support the vehicle. Never get under a vehicle when it is supported only by a jack.
8. Make sure the ignition is off when you disconnect the module or it could be permanently damaged.
9. Remove the connector(s) from the module. Follow the steps on the right to avoid breaking the plastic retaining clips.
10. Remove the screws that hold the module to the hydraulic control unit. If you cannot reach the screws easily or if the heads have rusted tight, jump to the section *Removing Difficult Modules* below.
11. Cover the exposed surface of the hydraulic unit with aluminum foil. Avoid driving your vehicle on dusty or wet roads if possible. Protect the plug

Continued on next page

ends of the cables from moisture with electrical tape as well. For those who have electronic four-wheel-drives, 4WD may not function properly until the ABS controller is reinstalled.

- 12.** You can still drive your vehicle since the brakes will not be impaired by removal of the ABS module. On certain vehicles, the speedometer receives an input signal from the ABS module and may not function until the module is back in place.

Removing Difficult Modules

Most people have reported successful removal of the ABS controller without disconnection of the brake lines. However, you may have to disconnect all five (5) hydraulic lines for successful removal if the roads you drive on are salted and the Torx T20 bolts are rusted in place. In such circumstance, it is best to remove the entire ABS assembly from the truck for easier removal of the ABS controller by drilling out the bolt heads.

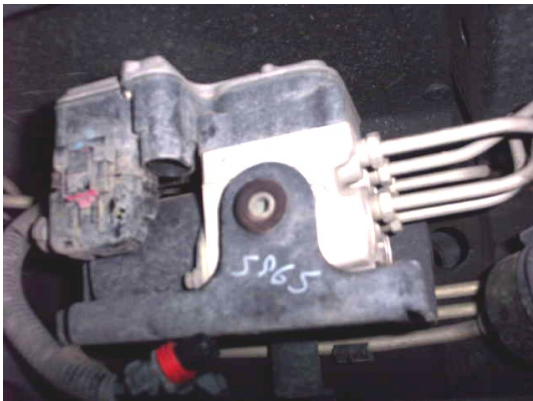

There is very little room to access these four bolts under the truck in such stubborn cases. It is suggested that you disconnect the lines and remove the entire assembly. Take the assembly to a workbench or drill press to drill/grind the heads off of the bolts. If this sounds too ugly and disconnecting the five brake lines will ruin your day; you can instead remove the three hex head bolts attaching the ABS pump/manifold to the vehicle frame and CAREFULLY lower it. You must

- 3)** Firmly squeeze the side of the connector with your thumb as indicated while pulling at the same time.



- 4)** The connector will release as shown. Some resistance is normal due to friction from the rubber "o-ring" seal.



support the heavy pump assembly so you don't kink the brake lines. Then you will have room to get a small grinder or Dremel Tool to grind the heads off of the evil rusted bolts.



Be sure to order a bolt replacement Kit to replace rusted or stripped out Torx ABS module bolts.

After removing the rusted bolts, separate the EBCM from the hydraulic unit. You do not need to worry about any parts falling out and no fluid will leak out. The six protruding valve bodies are permanently pressed into the aluminum housing and will not move or fall apart while the EBCM is removed for the repair.

Installation Procedure

1. Installation is the reverse of the above steps.
2. Removal of any of the brake lines will require bleeding of the brakes upon re-installation. Your vehicle is probably overdue for a brake fluid flush anyways. Brake fluid is hygroscopic (absorbs water) and the water molecules will congregate in the lowest parts of the brake system eventually corroding critical brake components. Modern vehicles should have their brake fluid flushed on a regular basis; so you are providing your vehicle a much needed service in the process of this repair.
3. Start the engine and make sure the brake warning lights go out.

ABS Module Removal & Installation Instructions	ModuleMaster
Chevy Tahoe	Support: 208-892-0764 www.modulemaster.com



2009 and later vehicles

Please call to find out if we can repair your module.