

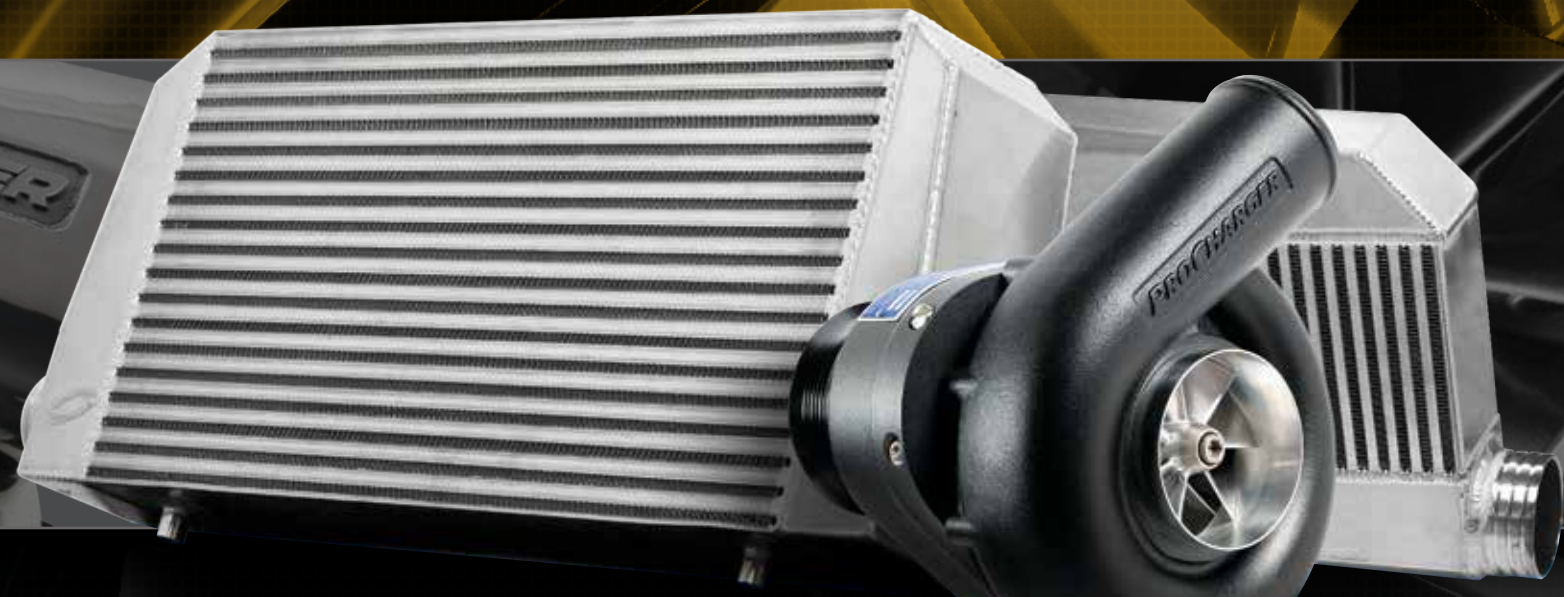

AUTOMOTIVE & TRUCK/SUV

APPLICATIONS, SPECIFICATIONS, AND RETAIL PRICE GUIDE



**EFFECTIVE
04/30/21**

Supersedes all previous price lists

**MADE IN
AMERICA**



CALL FOR 2021-22 MODEL YEARS

**THE WORLD'S BEST & BROADEST
SUPERCHARGER PRODUCT LINE**



FORD AUTOMOTIVE

2018-21 Mustang GT (5.0 4V)	4
2015-17 Mustang GT (5.0 4V)	4
2015-20 GT350 and GT350R (5.2 4V)	4
2015-17 Mustang V6 (3.7)	4
2011-14 Mustang GT (5.0 4V)	6
2011-14 Mustang GT (5.0 4V) i-1	6
2011-14 Mustang V6 (3.7 4V)	6
2012-13 Boss 302 Mustang	8
2012-13 Boss 302 Mustang i-1	8
2005-10 Mustang GT (4.6 3V)	10
2005-10 Mustang V6 (4.0)	10
1999-04 Mustang GT and 2001 Bullitt (4.6 2V)	12
2003-04 Mustang Mach 1 (4.6 4V)	12
1996-98 Mustang GT (4.6 2V)	12
1994-04 Mustang V6 (3.8, 3.9)	12
2003-04 Cobra (4.6 4V)	14
1999-01 Cobra (4.6 4V)	14
1996-98 Cobra (4.6 4V)	14
1994-95 Mustang, Cobra (5.0)	16
1986-93 Mustang, Cobra (5.0)	16
1964½-73 Early Ford Kits (289/302)	18
Carb/Aftermarket EFI Serpentine/Cog Race Kits	18-20
Coyote Engine Swap (5.0 4V) Kits	22
Godzilla Engine Swap (7.3) Kits	22

CHEVROLET/PONTIAC/GM AUTOMOTIVE

2020-21 Corvette C8 Stingray (LT2)	24
2014-19 Corvette C7 Stingray/Grand Sport (LT1)	26
2015-19 Corvette C7 Z06 (LT4)	26
2014-17 Corvette C7 Stingray (LT1) i-1	26
2008-13 Corvette C6 (LS3)	28
2006-13 Corvette C6 Z06 (LS7)	28
2005-07 Corvette C6 (LS2)	28
2008-13 Corvette C6 (LS3) i-1	28
1997-04 Corvette C5, Z06 (LS1, LS6)	30
1992-96 Corvette C4 (LT1, LT4)	30
1985-91 Corvette C4 TPI (L98)	30
2016-19 Cadillac CTS-V (LT4)	32
2017-21 Camaro ZL1 (LT4)	32
2016-21 Camaro SS (LT1)	32
2016-20 Camaro V6 (3.6)	32
2014-15 Camaro Z/28 (LS7)	34
2010-15 Camaro SS (LS3, L99)	34
2010-15 Camaro SS (LS3, L99) i-1	34
2010-15 Camaro SS Cog Race Kits	34
1998-02 Camaro/Firebird (LS1)	36
1993-97 Camaro/Firebird (LT1)	36
1987-92 Camaro/Firebird TPI (L98)	36
2014-17 Chevrolet SS	38
2008-09 Pontiac G8 GT	38
2004-06 Pontiac GTO (LS1, LS2)	38
Carb/Aftermarket EFI Serpentine and Cog Kits	40-42
LS Engine Swap Serpentine/Cog Race Kits	44
LT1/LT4 Engine Swap Serpentine Kits (2014+)	46
Passenger Side LSx Reverse Swap Kits	46

DODGE/CHRYSLER AUTOMOTIVE

2011-21 Dodge Challenger HEMI (6.4)	48
2011-21 Dodge Challenger HEMI (5.7)	48
2015-20 Dodge Challenger V6 (3.6)	48
2008-10 Dodge Challenger HEMI SRT8 (6.1)	50
2008-10 Dodge Challenger HEMI R/T (5.7)	50
2012-21 Dodge Charger HEMI SRT8 (6.4)	52
2011-21 Dodge Charger HEMI R/T (5.7)	52
2011-20 Dodge Charger V6 (3.6)	52
2006-10 Dodge Charger HEMI SRT8 (6.1)	54
2006-10 Dodge Charger HEMI R/T (5.7)	54
2012-14 Chrysler 300 HEMI SRT8 (6.4)	56
2011-20 Chrysler 300 HEMI (5.7)	56
2005-10 Chrysler 300 HEMI (6.1)	56
2005-10 Chrysler 300 HEMI (5.7)	56
2005-08 Dodge Magnum HEMI (6.1)	58
2005-08 Dodge Magnum HEMI (5.7)	58
HEMI Reverse Cog Race Kit	58

GM TRUCK/SUV

2019-21 GM Truck/SUV 1500 (6.2, 5.3)	60
2015-19 GM Truck/SUV 2500 (6.0)	60
2014-18 GM Truck/SUV 1500 (5.3, 6.2)	60
2007-13 GM Truck/SUV 1500 (5.3, 4.8)	62
2007-13 GM Truck/SUV 1500 (6.0, 6.2)	62
2007-13 GM Truck/SUV (5.3, 6.0, 6.2, 4.8) i-1	62
2003-07 GM Truck/SUV (5.3, 6.0, 6.2, 4.8)	64
2003-09 Hummer H2 (6.2, 6.0)	64
1999-03 GM Truck/SUV (5.3, 6.0, 4.8)	64
1999-07 GM 2500 Truck (6.0)	64
1996-00 GM Truck/SUV (5.7, 7.4)	64
1988-95 GM TBI Truck/SUV (5.7, 7.4)	64

FORD TRUCK/SUV

2020-21 Ford Super Duty (7.3)	66
2015-20 Ford F-150 (5.0 4V)	66
2011-14 Ford F-150 (5.0, 6.2 4V)	66
2011-14 Ford F-150 (5.0, 6.2 4V) i-1	66
2017-20 Ford F-150 SVT Raptor (3.5 EcoBoost)	68
2010-14 Ford F-150 SVT Raptor (6.2, 5.4 3V)	68
2010-14 Ford F-150 SVT Raptor (6.2) i-1	68
2004-10 Ford F-150 and Expedition (5.4 3V)	68
1997-03 Ford F-150 and Expedition (5.4, 4.6 2V)	68

DODGE/RAM TRUCK/SUV

2018-21 Dodge Durango SRT (6.4)	70
2014-21 Ram 2500/3500 and Power Wagon (6.4)	70
2011-21 Ram Classic / 1500 / eTorque (5.7)	70
2009-10 Ram Classic (5.7)	72
2004-08 Dodge Ram (5.7)	72
1996-01 Dodge Ram (5.9, 5.2)	72
1997-01 Dodge Dakota/Durango (5.9, 5.2)	72

JEEP

2012-20 Jeep Grand Cherokee SRT (6.4)	74
2011-20 Jeep Grand Cherokee (5.7)	74
2006-10 Jeep Grand Cherokee SRT8 (6.1)	74
2020-21 Jeep Wrangler JT (3.6)	74
2018-21 Jeep Wrangler JL (3.6)	74
2012-18 Jeep Wrangler JK (3.6)	74

TOYOTA

2010-20 4Runner (4.0)	76
2016-21 Tacoma (3.5)	76
2005-15 Tacoma (4.0)	76
2007-20 Tundra (5.7)	76

SPORT COMPACT

2015-19 Polaris Slingshot	78
2003-06 Nissan 350Z (3.5)	78
2003-04 Infiniti G35 Coupe, FX35 (3.5)	78
1999-00 Honda Civic SI (1.6L DOHC)	78
1994-01 Acura Integra GSR Type R (1.8L DOHC)	78
2000-04 Ford Focus (Zetec, SVT)	78

GENERAL INFORMATION

Street/Strip Supercharger Specifications	80
Race Supercharger Specifications	81
Supercharger Clocking	82
Street/Strip Supercharger Pulleys	83
Intercoolers for Custom Applications	84

PARTS AND COMPONENTS

CrankDrive, Rev BeltDrive, DragsterDrive	86
Superchargers & Upgrades	87-88
Supercharger Oil and Related Hardware	88
Pulleys, Belts and Drive System Components	89
Race Bellmouths	90
Intercooler Tubing Kits	90
Air Filters	90
Surge Valves	91
Carburetor Bonnets & Components	91
Field Upgrades	92
Accessory Relocation Brackets	92
Fuel System Components and Gauges	93
Merchandise and Apparel	94
Product Catalogs	95





PROCHARGER COMPLETE SYSTEMS

- ProCharger systems are sold 100% complete unless noted otherwise.
- High Output (HO) Intercooled Systems are designed for operation on vehicles with stock engines and stock exhaust.
- Stage II Intercooled Systems are designed to accommodate higher power levels, but tuning is provided for stock vehicles only.
- Tuning is available for Systems only, and only for vehicles with stock engines with stock exhaust, as well as most “cat-back” exhaust systems.
- Complete systems with tuning require a minimum of US 91 octane gas.
- All engine and exhaust modifications must be noted at time of order. ProCharger is not responsible for boost levels or quality of tune for modified applications.
- Vehicles built for export and other non-US spec vehicles may require custom tuning/calibrations.
- ProCharger systems for stock vehicles are emissions legal in all 50 states where noted in the “CARB EO” column in the product specs. For compliance information, visit www.arb.ca.gov
- Due to variability among OEM computers and the prevalence of custom modifications, dyno tuning may be required; stock vehicles with cat-back exhaust systems may also require custom tuning.

PROCHARGER TUNER KITS

- ProCharger Tuner Kits exclude fuel components and computer programming, but are otherwise identical to complete systems.
- HO Intercooled Tuner Kits are designed for stock and modified vehicles.
- Stage II Intercooled Tuner Kits accommodate higher power levels, and are designed for both stock and modified vehicles.
- Race kits and components are intended for off-road/racing use only and may require modifications, trimming, and/or additional components.
- Tuner kits are intended to be dyno-tuned by professional tuners/installers with custom programming.

GENERAL INFORMATION

- You must list Minimum Advertised Pricing (MAP) equal to PRICE as displayed throughout this price guide. MAP = PRICE
- All prices and specifications are subject to change without prior notification. The most recently printed price guide supersedes all previous statements of product specifications and/or pricing.
- Payment is required in advance before product may be shipped. ATI accepts payment in the form of credit card (USA only), cashier's check, certified check, wire transfers or money order. Payments made by company check, cashier's check, certified check or money order may cause shipping delays while check clears, unless prior arrangements have been made with ATI.
- All products are shipped F.O.B. Accessible Technologies, Inc., Lenexa, KS. Standard shipping is via Federal Express Ground unless prior arrangements have been made with ATI.
- A drop shipment fee will apply to all system, kit and head unit orders not shipped to the purchasing dealer. \$35 for systems and kit orders, \$25 for head unit orders.
- Customer is responsible for all duties, customs, fees and shipping charges required to get product to its destination. Export shipping must be arranged in advance with ATI. All payments on export orders must be made in U.S. funds via wire transfer.
- Drop ship orders may be subject to local sales tax requirements.
- Estimated shipping dates can be obtained from ATI sales or customer service (dates are estimated and not guaranteed).
- All packed orders not shipped within 30 days will be returned to inventory and subject to a 5% restocking fee.
- Inspection of product should occur immediately upon arrival. Any claims of shortages or errors originating at ATI must be made within 5 business days from the date of receipt. Damage to product or packaging must be claimed in accordance with the carrier's policies.
- CARB EO's are applicable at time of purchase and are not retroactive. Only systems with an EO# meet emission requirements for all 50 states and are legal for street use on OEM vehicles only (stock engine, stock exhaust, etc).
- F-Series superchargers may require bellmouth or custom air inlet.
- Model years listed in App guide may not be available at time of print. Call for more details.

WARRANTY INFORMATION

- 12-month warranty on new, serpentine head unit purchases. Warranty does not cover owner misuse or neglect.
- 36-month head unit warranty option is available on new, complete systems with P-series head units.
- Limited warranty on cog drive, gear drive or race head unit purchases. Limited means free of manufacturing defects upon receipt.
- 90-day limited warranty on serpentine head unit upgrades.
- 30-day limited warranty on serpentine head unit rebuilds/repairs.
- Exceeding the published supercharger RPM, failure to follow service procedures, or using improper supercharger orientation will void the warranty. The ProCharger warranty applies to original purchaser only and is non-transferrable.
- Failure to use ProCharger specified oil in head units, and drives, will void ProCharger manufacturer warranty.
- 90-day limited warranty on components purchased separately (excludes electrical and fuel components).
- 30-day limited warranty on electrical components and fuel components.
- 3-year limited warranty on new air-to-air intercoolers.
- 1-year limited warranty on new air-to-water intercoolers.
- Wastegates, methanol injection kits, aftermarket intakes, etc may cause damage to ProCharger supercharger, intercooler, or intake that will not be covered under warranty.

RETURNS

- Returns of new, unused product must be pre-approved by ATI/ProCharger. A 20% restocking fee will apply to part orders and head units, and a 12.5% restocking fee will apply to supercharger systems.
- Supercharger systems returned with the factory seal intact are subject to a restocking fee of 10%. No C.O.D or Freight Collect shipments will be accepted by ATI. Used, damaged, special order or discontinued items may not be returned.
- An RMA (Returned Merchandise Authorization) number must be assigned by ATI for all returns and must be displayed in clear view on the outside of the package and be contained in all correspondence.
- No returns are accepted after 90 days. Returns for electrical and fuel components are limited to 30 days.

2018-21 MUSTANG GT, BULLITT AND CALIFORNIA SPECIAL (5.0 4V) SYSTEMS AND KITS

Year	Part Number	Description	Boost Options	HP Gain	Intercooler	Price
2018-20	1FW611-SCI	High Output Intercooled System with Factory Airbox and P-1SC-1	6.5 psi	55-60%+	750+ HP	\$6,999
2018-20	1FW601-SCI	High Output Intercooled Tuner Kit with Factory Airbox and P-1SC-1	specify	specify	750+ HP	\$6,449
2018-20	1FW614-SCI	High Output Intercooled System with P-1SC-1	6.5 psi	55-60%+	750+ HP	\$6,999
2018-20	1FW604-SCI	High Output Intercooled Tuner Kit with P-1SC-1	specify	specify	750+ HP	\$6,399
2018-20	1FW613-SCI	Stage II Intercooled System with Factory Airbox and P-1SC-1	8.5 psi	65-70%+	1200+ HP	\$7,999
2018-20	1FW603-SCI	Stage II Intercooled Tuner Kit with Factory Airbox and P-1SC-1	specify	specify	1200+ HP	\$6,949
2018-20	1FW612-SCI	Stage II Intercooled System with P-1SC-1	8.5 psi	65-70%+	1200+ HP	\$7,999
2018-20	1FW602-SCI	Stage II Intercooled Tuner Kit with P-1SC-1	specify	specify	1200+ HP	\$7,249

2015-17 MUSTANG GT (5.0 4V) SYSTEMS AND KITS

Year	Part Number	Description	Boost Options	HP Gain	Intercooler	Price
2015-17	1FW411-SCI	High Output Intercooled System with Factory Airbox and P-1SC-1	8 psi	55-60%+	750+ HP	\$6,999
2015-17	1FW401-SCI	High Output Intercooled Tuner Kit with Factory Airbox and P-1SC-1	specify	specify	750+ HP	\$6,299
2015-17	1FW214-SCI	High Output Intercooled System with P-1SC-1	8 psi	55-60%+	750+ HP	\$6,999
2015-17	1FW204-SCI	High Output Intercooled Tuner Kit with P-1SC-1	specify	specify	750+ HP	\$6,299
2015-17	1FW412-SCI	Stage II Intercooled System with Factory Airbox and P-1SC-1	9 psi	60-65%+	1200+ HP	\$7,899
2015-17	1FW402-SCI	Stage II Intercooled Tuner Kit with Factory Airbox and P-1SC-1	specify	specify	1200+ HP	\$6,749
2015-17	1FW212-SCI	Stage II Intercooled System with P-1SC-1	10 psi	65-70%+	1200+ HP	\$8,399
2015-17	1FW202-SCI	Stage II Intercooled Tuner Kit with P-1SC-1	specify	specify	1200+ HP	\$6,899

2015-20 GT350 AND GT350R (5.2 4V) SYSTEMS AND KITS

Year	Part Number	Description	Boost Options	HP Gain	Intercooler	Price
2015-20	1FW312-SCI	High Output Intercooled System with P-1SC-1	6 psi	175+ HP	1100+ HP	\$7,549
2015-20	1FW302-SCI	High Output Intercooled Tuner Kit with P-1SC-1	specify	specify	1100+ HP	\$6,749
2015-20	1FW314-SCI	Stage II Intercooled System with P-1SC-1	9 psi	350 + HP	1100+ HP	\$8,899
2015-20	1FW304-SCI	Stage II Intercooled Tuner Kit with P-1SC-1	specify	specify	1100+ HP	\$7,849

2015-17 MUSTANG V6 (3.7V) SYSTEMS AND KITS

Year	Part Number	Description	Boost Options	HP Gain	Intercooler	Price
2015-17	1FT412-SCI	Intercooled Supercharger System with P-1SC-1	8 psi	50-55%	750+ HP	\$6,799
2015-17	1FT402-SCI	Intercooled Supercharger Tuner Kit with P-1SC-1	specify	specify	750+ HP	\$6,199

2015-20 MUSTANG GT GT350 AND V6 OPTIONS	add "-B" or "-P" to part #	Black or Polished finish for ProCharger (P-series or D-series)	satin standard	-	-	+\$295
	add "-B" or "-P" to part #	Black or Polished finish for ProCharger (F-series, 9" or 9.75" housing)	satin standard	-	-	+\$325
	add "-BB" or "-PB" to part #	Black or Polished finish for supercharger bracket	satin standard	-	-	+\$250
	add "-BI" to part #	Black finish for Intercooler (1200+ HP Intercooler Only)	satin standard	-	-	+\$150
	add "-H" to part #	Helical gerset for noise reduction (P-1SC-1, P-1X, D-1SC, D-1X)	same	same	-	+\$100
	add "-D1SC" to part #	With D-1SC ProCharger (replacing P-1SC-1)	tuner kit only	specify	-	+\$250
	add "-BV" to part #	Bullet Bypass Valve Upgrade	black only	-	-	+\$105
	add "-Race" to part #	1200+ HP Intercooler Upgrade (replacing 750+ HP intercooler) - Tuner kits only	HO GT only	1200+ hp	-	+\$345
2015-20 MUSTANG GT AND GT350 ONLY OPTIONS	add "-P1X" to part #	With P-1X ProCharger (replacing P-1SC-1, Systems and Tuner Kits)	same	add'l 15+ hp	-	+\$200
	add "-D1X" to part #	With D-1X ProCharger (replacing P-1SC-1, Tuner Kits only)	tuner kit only	specify	-	+\$425
	add "-D" or "-1" or "-A"	With F-1D, F-1, F-1A ProCharger (replacing P-1SC-1)	tuner kit only	specify	-	+\$775
	add "-94" or "-C" or "-R"	With F-1A-94, F-1C or F-1R (replacing P-1SC-1, Stage II Tuner kits only)	tuner kit only	-	-	+\$1,100
	add "-RVR" or "-RVB"	Race Bypass Valve Upgrade (open only)	red or black	specify	-	+\$295
	add "-INJ" to part #	95 lb/hr Fuel Injectors (Tuner kits only)	tuner kit only	specify	-	+\$679
	add "-CS" to part #	Coyote Crank Support	satin standard	-	-	+\$599
GT350 ONLY	add "-BC" or "-PC" to part #	Black or Polished finish for Crank Support	satin standard	-	-	+\$250
V6 ONLY	add "-CP" to part #	7.00" Crank Pulley Upgrade	6.25" standard	-	-	+\$107
	add "-AIR" to part #	Stage II air inlet upgrade package (replacing HO standard inlet)	same	specify	-	+\$39

2021 MUSTANG GT AND MACH 1 - COMING SOON - CALL FOR DETAILS

SPECIFICATIONS (2015-21 MUSTANG)

2018-21 MUSTANG GT, BULLITT AND CALIFORNIA SPECIAL (5.0 4V) SPECIFICATIONS

Year	Part Number	OEM HP Rating	HP Gain	Tube Diam	Intercooler Mount	Drive System	Bypass System	Fuel System Upgrade	Fuel Inj. Supplied	Computer/Ignition Modifications	Supercharger Warranty (in months)	CARB E.O.	Foot Notes
2018-20	1FW611-SCI	460	50-60%+	3-3.5"	V	stk 6 rib	ProFlow	not required	not required	programmer supplied	12, 36 opt. (\$99)	D-365-21	A2, A3, A5, A8
2018-20	1FW601-SCI	460	specify	3-3.5"	V	stk 6 rib	ProFlow	not supplied	No	not supplied	12	-	A3, A5, A8
2018-20	1FW614-SCI	460	50-60%+	3-3.5"	V	stk 6 rib	ProFlow	not required	not required	programmer supplied	12, 36 opt. (\$99)	-	A2, A3, A5, A8, A11
2018-20	1FW604-SCI	460	specify	3-3.5"	V	stk 6 rib	ProFlow	not supplied	No	not supplied	12	-	A3, A5, A8, A11
2018-20	1FW613-SCI	460	50-60%+	3-3.5"	V	stk 6 rib	ProFlow	pump voltage booster	not required	programmer supplied	12, 36 opt. (\$99)	D-365-21	A2, A3, A5, A8
2018-20	1FW603-SCI	460	specify	3-3.5"	V	stk 6 rib	ProFlow	not supplied	No	not supplied	12	-	A3, A5, A8
2018-20	1FW612-SCI	460	65-70%+	3-3.5"	V	add'l 8 rib	ProFlow	not required	not required	programmer supplied	12, 36 opt. (\$99)	-	A2, A3, A5, A8
2018-20	1FW602-SCI	460	specify	3-3.5"	V	add'l 8 rib	ProFlow	not supplied	No	not supplied	12	-	A3, A5, A8, A12

2015-17 MUSTANG GT (5.0 4V) SPECIFICATIONS

Year	Part Number	OEM HP Rating	HP Gain	Tube Diam	Intercooler Mount	Drive System	Bypass System	Fuel System Upgrade	Fuel Inj. Supplied	Computer/Ignition Modifications	Supercharger Warranty (in months)	CARB E.O.	Foot Notes
2015-17	1FW411-SCI	435	60-65%+	3"	V	stk 6 rib	ProFlow	not required	52 lb/hr	programmer supplied	12, 36 opt. (\$99)	D-365-16	A1, A3, A4, A5, A8
2015-17	1FW401-SCI	435	specify	3"	V	stk 6 rib	ProFlow	not supplied	No	not supplied	12	-	A1, A3, A4, A5, A8
2015-17	1FW214-SCI	435	60-65%+	3"	V	stk 6 rib	ProFlow	not required	52 lb/hr	programmer supplied	12, 36 opt. (\$99)	-	A1, A2, A3, A4, A5, A8
2015-17	1FW204-SCI	435	specify	3"	V	stk 6 rib	ProFlow	not supplied	No	not supplied	12	-	A1, A3, A4, A5, A8
2015-17	1FW412-SCI	435	65-70%+	3"	V	stk 6 rib	ProFlow	pump voltage booster	52 lb/hr	programmer supplied	12, 36 opt. (\$99)	D-365-16	A1, A3, A4, A5, A8
2015-17	1FW202-SCI	435	specify	3"	V	stk 6 rib	ProFlow	not supplied	No	not supplied	12	-	A1, A3, A4, A5, A6, A8
2015-17	1FW212-SCI	435	65-70%+	3"	V	add'l 8 rib	ProFlow	pump voltage booster	95 lb/hr	programmer supplied	12, 36 opt. (\$99)	-	A1, A2, A3, A4, A5, A8, A10
2015-17	1FW202-SCI	435	specify	3"	V	add'l 8 rib	ProFlow	not supplied	No	not supplied	12	-	A1, A3, A4, A5, A6, A8, A10

2015-20 GT350 AND GT350R (5.2 4V) SPECIFICATIONS

Year	Part Number	OEM HP Rating	HP Gain	Tube Diam	Intercooler Mount	Drive System	Bypass System	Fuel System Upgrade	Fuel Inj. Supplied	Computer/Ignition Modifications	Supercharger Warranty (in months)	CARB E.O.	Foot Notes
2015-19	1FW312-SCI	526	175+hp	3"	V	stk 6 rib	ProFlow	not required	95 lb/hr	programmer supplied	12, 36 opt. (\$99)	-	A1, A2, A3, A4, A5, A8, A11
2015-19	1FW302-SCI	526	specify	3"	V	stk 6 rib	ProFlow	not supplied	No	not supplied	12	-	A1, A3, A4, A5, A8, A11
2015-19	1FW314-SCI	526	350+hp	3"	V	add'l 8 rib	ProFlow	not supplied	95 lb/hr	programmer supplied	12, 36 opt. (\$99)	-	A1, A2, A3, A8, A9
2015-19	1FW304-SCI	526	specify	3"	V	add'l 8 rib	ProFlow	not supplied	No	not supplied	12	-	A1, A3, A8, A9

2015-17 MUSTANG V6 (3.7V) SPECIFICATIONS

Year	Part Number	OEM HP Rating	HP Gain	Tube Diam	Intercooler Mount	Drive System	Bypass System	Fuel System Upgrade	Fuel Inj. Supplied	Computer/Ignition Modifications	Supercharger Warranty (in months)	CARB E.O.	Foot Notes
2015-17	1FT412-SCI	300	50-55%	3"	V	add'l 6 rib	ProFlow	not required	50 lb/hr	programmer supplied	12, 36 opt. (\$99)	-	A1, A2, A3, A7, A8
2015-17	1FT402-SCI	300	specify	3"	V	add'l 6 rib	ProFlow	not supplied	No	not supplied	12	-	A1, A3, A7, A8

FORD AUTOMOTIVE FOOTNOTES (specific to above applications):

- | | |
|--|--|
| <p>A1) Model year must be specified</p> <p>A2) Due to variability among OEM computers and the prevalence of custom modifications, dyno tuning may be required; stock vehicles with cat-back exhaust systems may also require custom tuning</p> <p>A3) System ships in extra large box</p> <p>A4) California Special models may require trimming</p> <p>A5) Specify factory or aftermarket balancer</p> | <p>A6) Fan shroud trimming is required in 2015-19 Mustang GT vehicles equipped with F-1C/F-1R</p> <p>A7) Upgraded driveshaft recommended</p> <p>A8) Specify manual or automatic transmission</p> <p>A9) Aftermarket balancer is included in Stage II GT350 Systems and Kits</p> <p>A10) Factory sway bar only</p> <p>A11) Minor timing cover modifications may be required.</p> <p>A12) Crank Support requires removal of factory sway bar</p> |
|--|--|



2011-14 MUSTANG GT (5.0 4V) SYSTEMS AND KITS

Year	Part Number	Description	Boost Options	HP Gain	Intercooler	Price
2011-14	1FR211-SCI	HO Intercooled System with Factory Airbox and P-1SC-1 (shared drive)	7.5 psi	50%+	750+ HP	\$6,749
2011-14	1FR201-SCI	HO Intercooled Tuner Kit with Factory Airbox and P-1SC-1 (shared drive)	specify	specify	750+ HP	\$5,999
2011-12	1FR14-SCI	High Output Intercooled System with P-1SC-1	7.5 psi	50%+	3 core	\$6,999
2011-12	1FR204-SCI	High Output Intercooled Tuner Kit with P-1SC-1	specify	specify	3 core	\$6,249
2011-14	1FR212-SCI	Stage II Intercooled System with P-1SC-1	8 psi	55%+	Stage II	\$7,599
2011-14	1FR202-SCI	Stage II Intercooled Tuner Kit with P-1SC-1	specify	specify	Stage II	\$6,849
2011-14	1FR200-F1	Intercooled Cog Race Kit with F-1D, F-1 or F-1A	specify	specify	Race	\$7,999
2011-14	1FR200-F1R	Intercooled Cog Race Kit with F-1A-94, F-1C or F-1R	specify	specify	Race	\$8,299

2011-14 MUSTANG GT OPTIONS	add "-B" or "-P" to part #	Black or Polished finish for ProCharger (P-series or D-series)	satin standard	-	-	+\$295
	add "-B" or "-P" to part #	Black or Polished finish for ProCharger (F-series, 9" or 9.75" housing)	satin standard	-	-	+\$325
	add "-BB" or "-PB" to part #	Black or Polished finish for supercharger bracket	satin standard	-	-	+\$250
	add "-H" to part #	Helical gerset for noise reduction (P-1SC-1, P-1X, D-1SC, D-1X)	same	same	-	+\$100
	add "-P1X" to part #	With P-1X ProCharger (replacing P-1SC-1, Systems and Tuner Kits)	same	add'l 10-15+ hp	-	+\$200
	add "-D1SC" to part #	With D-1SC ProCharger (replacing P-1SC-1)	tuner kit only	specify	-	+\$250
	add "-D1X" to part #	With D-1X ProCharger (replacing P-1SC-1, Tuner Kits only)	tuner kit only	specify	-	+\$425
	add "-D" or "-1" or "-A"	With F-1D, F-1, F-1A ProCharger (replacing P-1SC-1)	tuner kit only	specify	-	+\$775
	add "-94" or "-C" or "-R"	With F-1A-94, F-1C or F-1R (replacing P-1SC-1, Stage II Tuner Kits only)	tuner kit only	-	-	+\$1,100
	add "-RVR" or "RVB"	Race Bypass Valve Upgrade (specify open or closed valve)	red or black	specify	-	+\$295
	add "-10R" to part #	10 rib drive system upgrade (2011-14 Stage II Tuner Kits only)	from 8 rib	-	-	+\$230
add "-AIR" to part #	Stage II air inlet upgrade package (replacing HO standard inlet)	same	specify	-	+\$39	
add "-Race" to part #	Air-to-Air Race intercooler upgrade	from Stage II	1000 hp max	3" Tubing	+\$345	

2011-14 MUSTANG GT (5.0 4V) i-1 PROGRAMMABLE RATIO SYSTEMS

Year	Part Number	Description	Boost Options	HP Gain	Intercooler	Price
2011-14	1FR215-SCI	Stage II Intercooled System with i-1	7.5 psi	55%+	Stage II	\$8,799

i-1 OPTIONS	add "-T" to part #	Touchscreen (at time of system purchase)	-	-	-	+\$395
	add "-B" to part #	Black finish (supercharger and bracket)	satin standard	-	-	+\$795
	add "-P" to part #	Polished finish (supercharger and bracket)	satin standard	-	-	+\$595
	add "-R" to part #	Air-to-air race intercooler upgrade	satin standard	-	-	+\$345

2011-14 MUSTANG V6 (3.7) SYSTEMS AND KITS

Year	Part Number	Description	Boost Options	HP Gain	Intercooler	Price
2011-14	1FT212-SCI	Intercooled Supercharger System with P-1SC-1	8 psi	50-60%	3 core	\$6,699
2011-14	1FT202-SCI	Intercooled Supercharger Tuner Kit with P-1SC-1	specify	specify	3 core	\$5,999

2011-14 MUSTANG V6 (3.7) OPTIONS	add "-B" or "-P" to part #	Black or Polished finish for ProCharger (P-series or D-series)	satin standard	-	-	+\$295
	add "-BB" or "-PB" to part #	Black or Polished finish for supercharger bracket	satin standard	-	-	+\$250
	add "-H" to part #	Helical gerset for noise reduction (P-1SC-1, D-1SC)	same	same	-	+\$100
	add "-D1SC" to part #	With D-1SC ProCharger (replacing P-1SC-1)	tuner kit only	-	-	+\$250
	add "-AIR" to part #	With cold air inlet upgrade package (replacing standard inlet)	same	specify	-	+\$39

FOR COYOTE & GODZILLA ENGINE SWAP KITS, SEE PAGE 22

SPECIFICATIONS (2011-14 MUSTANG)

2011-14 MUSTANG GT (5.0 4V) SPECIFICATIONS

Year	Part Number	OEM HP Rating	HP Gain	Tube Diam	IC Mount	Drive System	Bypass System	Fuel System Upgrade	Fuel Inj. Supplied	Computer/Ignition Modifications	Supercharger Warranty (in months)	CARB E.O.	Foot Notes
2011-14	1FR211-SCI	412	50%+	3"	V	stk 6 rib	ProFlow	not required	52 lb/hr	programmer supplied	12, 36 opt. (\$99)	Call	B1, B2, B4, B5, B6, B10, B12
2011-14	1FR201-SCI	412	specify	3"	V	stk 6 rib	ProFlow	not supplied	No	not supplied	12	-	B1, B4, B5, B6, B10
2011-12	1FR214-SCI	412	50%+	3"	V	add'l 8 rib	ProFlow	not required	52 lb/hr	programmer supplied	12, 36 opt. (\$99)	-	B1, B2, B4, B5, B6, B8, B10, B11, B12
2011-12	1FR204-SCI	412	specify	3"	V	add'l 8 rib	ProFlow	not supplied	No	not supplied	12	-	B1, B4, B5, B6, B8, B9, B10, B11
2011-14	1FR212-SCI	412	55%+	3"	V	add'l 8 rib	ProFlow	not required	52 lb/hr	programmer supplied	12, 36 opt. (\$99)	-	B1, B2, B4, B5, B7, B8, B10, B11, B12
2011-14	1FR202-SCI	412	specify	3"	V	add'l 8 rib	ProFlow	not supplied	No	not supplied	12	-	B1, B4, B5, B7, B8, B9, B10, B11
2011-14	1FR200-F1	-	specify	3"	V	cog	Race	not supplied	No	not supplied	-	-	B1, B3, B4, B5, B8, B9, B10
2011-14	1FR200-F1R	-	specify	3"	V	cog	Race	not supplied	No	not supplied	-	-	B1, B3, B4, B5, B8, B9, B10

2011-14 MUSTANG GT (5.0 4V) i-1 PROGRAMMABLE RATIO SPECIFICATIONS

Year	Part Number	OEM HP Rating	HP Gain	Tube Diam	IC Mount	Drive System	Bypass System	Fuel System Upgrade	Fuel Inj. Supplied	Computer/Ignition Modifications	Supercharger Warranty (in months)	CARB E.O.	Foot Notes
2011-14	1FR215-SCI	412	55%+	3"	V	add'l 8 rib	ProFlow	not required	52 lb/hr	programmer supplied	12, 36 opt. (\$149)	-	B1, B2, B4, B8, B10, B12, B14

2011-14 MUSTANG V6 (3.7 4V) SPECIFICATIONS

Year	Part Number	OEM HP Rating	HP Gain	Tube Diam	IC Mount	Drive System	Bypass System	Fuel System Upgrade	Fuel Inj. Supplied	Computer/Ignition Modifications	Supercharger Warranty (in months)	CARB E.O.	Foot Notes
2011-14	1FT212-SCI	305	50-60%	3"	V	add'l 6 rib	ProFlow	not required	50 lb/hr	programmer supplied	12, 36 opt. (\$99)	-	B1, B2, B4, B12, B13
2011-14	1FT202-SCI	305	specify	3"	V	add'l 6 rib	ProFlow	not required	No	not supplied	12	-	B1, B4, B13

FORD AUTOMOTIVE FOOTNOTES (specific to above applications):

- B1) Model year must be specified
- B2) Due to variability among OEM computers, and the prevalence of custom modifications, dyno tuning may be required; stock vehicles with cat-back exhaust systems may also require custom tuning
- B3) Modified engines only
- B4) System ships in extra large box
- B5) California Special models may require trimming
- B6) Fog lights may need to be removed in 2013-14 Mustang GT vehicles with HO Systems and Kits
- B7) 2011-12 Stage II Systems require trimming of plastic bumper cover (behind bumper, not visible)
- B8) Specify factory or aftermarket balancer
- B9) Mustang ATI Balancer #918047 required for 12-rib upgrade and Cog Kits (not included - specify hardened hub)
- B10) Specify if vehicle has optional Ford track-pack package
- B11) Stage II air inlet does not fit in 2011-14 Mustang GT vehicles equipped with upper strut bar
- B12) ECM code required
- B13) Upgraded driveshaft recommended
- B14) Two-part shipment, additional shipping charges may apply



2012-13 BOSS 302 MUSTANG SYSTEMS AND KITS

Year	Part Number	Description	Boost Options	HP Gain	Intercooler	Price
2012-13	1FR311-SCI	HO Intercooled System with Factory Airbox and P-1SC-1 (shared drive)	8.5 psi	50%+	750+ HP	\$6,849
2012-13	1FR301-SCI	HO Intercooled Tuner Kit with Factory Airbox and P-1SC-1 (shared drive)	specify	specify	750+ HP	\$6,099
2012-13	1FR312-SCI	Stage II Intercooled System with P-1SC-1	8.5 psi	50%+	Stage II	\$7,699
2012-13	1FR302-SCI	Stage II Intercooled Tuner Kit with P-1SC-1	specify	specify	Stage II	\$6,949
2012-13	1FR300-F1	Intercooled Cog Race Kit with F-1D, F-1 or F-1A	specify	specify	Race	\$8,049
2012-13	1FR300-F1R	Intercooled Cog Race Kit with F-1A-94, F-1C or F-1R	specify	specify	Race	\$8,349

2012-13 BOSS 302 OPTIONS	add "-B" or "-P" to part #	Black or Polished finish for ProCharger (P-series or D-series)	satin standard	-	-	+\$295
	add "-B" or "-P" to part #	Black or Polished finish for ProCharger (F-series, 9" or 9.75" housing)	satin standard	-	-	+\$325
	add "-BB" or "-PB" to part #	Black or Polished finish for supercharger bracket	satin standard	-	-	+\$250
	add "-H" to part #	Helical gearset for noise reduction (P-1SC-1, P-1X, D-1SC, D-1X)	same	same	-	+\$100
	add "-P1X" to part #	With P-1X ProCharger (replacing P-1SC-1, Systems and Tuner Kits)	same	add'l 10-15+ hp	-	+\$200
	add "-D1SC" to part #	With D-1SC ProCharger (replacing P-1SC-1)	tuner kit only	specify	-	+\$250
	add "-D1X" to part #	With D-1X ProCharger (replacing P-1SC-1, Tuner Kits only)	tuner kit only	specify	-	+\$425
	add "-D" or "-1" or "-A"	With F-1D, F-1, F-1A ProCharger (replacing P-1SC-1)	tuner kit only	specify	-	+\$775
	add "-94" or "-C" or "-R"	With F-1A-94, F-1C or F-1R ProCharger (replacing P-1SC-1)	tuner kit only	-	-	+\$1,100
	add "-12R" to part #	12 rib drive system upgrade (Stage II tuner kits only)	from 8 rib	-	-	+\$230
add "-RVR" or "RVB"	Race Bypass Valve Upgrade (specify open or closed valve)	red or black	specify	-	+\$295	
add "-Race" to part #	Air-to-Air Race intercooler upgrade (Stage II only)	from Stage II	1000 hp max	3" Tubing	+\$345	

2012-13 BOSS 302 MUSTANG i-1 PROGRAMMABLE RATIO SYSTEMS

Year	Part Number	Description	Boost Options	HP Gain	Intercooler	Price
2012-13	1FR315-SCI	Stage II Intercooled System with i-1	8.5 psi	55%+	Stage II	\$8,799
i-1 OPTIONS	add "-T" to part #	Touchscreen (at time of system purchase)	-	-	-	+\$395
	add "-B" to part #	Black finish (supercharger and bracket)	satin standard	-	-	+\$795
	add "-P" to part #	Polished finish (supercharger and bracket)	satin standard	-	-	+\$595
	add "-R" to part #	Air-to-Air Race Intercooler upgrade	-	-	-	+\$345

FOR COYOTE & GODZILLA ENGINE SWAP KITS, SEE PAGE 22

SPECIFICATIONS (2012-13 BOSS 302 MUSTANG)

2012-13 BOSS 302 MUSTANG SPECIFICATIONS

Year	Part Number	OEM HP Rating	HP Gain	Tube Diam	Intercooler Mount	Drive System	Bypass System	Fuel System Upgrade	Fuel Inj. Supplied	Computer/Ignition Modifications	Supercharger Warranty (in months)	CARB E.O.	Foot Notes
2012-13	1FR311-SCI	444	50%+	3"	V	stk 6 rib	ProFlow	not required	52 lb/hr	programmer supplied	12, 36 opt. (\$99)	Call	C1, C2, C4, C8, C9
2012-13	1FR301-SCI	444	specify	3"	V	stk 6 rib	ProFlow	not supplied	No	not supplied	12	-	C1, C4
2012-13	1FR312-SCI	444	50%+	3"	V	add'l 8 rib	ProFlow	pump voltage booster	52 lb/hr	programmer supplied	12, 36 opt. (\$99)	-	C1, C2, C4, C5, C6, C7, C8, C9
2012-13	1FR302-SCI	444	specify	3"	V	add'l 8 rib	ProFlow	not supplied	No	not supplied	12	-	C1, C4, C5, C6, C7
2012-13	1FR300-F1	-	specify	3"	V	cog	Race	not supplied	No	not supplied	Limited	-	C1, C3, C4, C7
2012-13	1FR300-F1R	-	specify	3"	V	cog	Race	not supplied	No	not supplied	Limited	-	C1, C3, C4, C7

2012-13 BOSS 302 MUSTANG i-1 PROGRAMMABLE RATIO SPECIFICATIONS

Year	Part Number	OEM HP Rating	HP Gain	Tube Diam	Intercooler Mount	Drive System	Bypass System	Fuel System Upgrade	Fuel Inj. Supplied	Computer/Ignition Modifications	Supercharger Warranty (in months)	CARB E.O.	Foot Notes
2012-13	1FR315-SCI	444	55%+	3"	V	add'l 8 rib	ProFlow	pump voltage booster	52 lb/hr	programmer supplied	12, 36 opt. (\$149)	-	C1, C2, C4, C6, C8, C9, C10

FORD AUTOMOTIVE FOOTNOTES (specific to above applications):

- C1) Model year must be specified
- C2) Due to variability among OEM computers, and the prevalence of custom modifications, dyno tuning may be required
- C3) Modified engines only
- C4) System ships in extra large box
- C5) 2012 Stage II Systems require trimming of plastic bumper cover (behind bumper, not visible)
- C6) Specify factory or aftermarket balancer
- C7) Mustang ATI Balancer #918047 required for 12-rib upgrade and Cog Kits
- C8) ProCharger tune overrides Ford TrackKey/Boss 302 performance calibrations
- C9) ECM code required
- C10) Two-part shipment, additional shipping charges may apply



2005-10 MUSTANG GT (4.6 3V) SYSTEMS AND KITS

Year	Part Number	Description	Boost Options	HP Gain	Intercooler	Price
2005-10	1FP311-SCI	Intercooled Supercharger System with P-1SC-1 (shared drive)	10 psi	70-75%	3 core	\$6,399
2005-10	1FP301-SCI	Intercooled Supercharger Tuner Kit with P-1SC-1 (shared drive)	specify	specify	3 core	\$5,599
2005-10	1FP214-SCI	High Output Intercooled System with P-1SC-1	10 psi	70-75%	3 core	\$6,649
2005-10	1FP204-SCI	High Output Intercooled Tuner Kit with P-1SC-1	specify	specify	3 core	\$5,849
2005-09	1FP211-SCI	Stage II Intercooled System with P-1SC-1	10 psi	70-75%	3 core	\$7,099
2005-09	1FP202-SCI	Stage II Intercooled Tuner Kit with P-1SC-1	specify	specify	3 core	\$6,299
2005-09	1FP213-F1	Intercooled Serp Race Kit (12 rib) with F-1A	specify	specify	800+ hp	\$7,499

2005-10 MUSTANG GT (4.6 3V) OPTIONS	add "-B" or "-P" to part #	Black or Polished finish for ProCharger (P-series or D-series)	satin standard	-	-	+\$295
	add "-B" or "-P" to part #	Black or Polished finish for ProCharger (F-series, 9" or 9.75" housing)	satin standard	-	-	+\$325
	add "-PT" to part #	Polished finish for throttle body tube inlet	satin standard	-	-	+\$150
	add "-BB" or "-PB" to part #	Black or Polished finish for supercharger bracket	satin standard	-	-	+\$250
	add "-H" to part #	Helical gearset for noise reduction (P-1SC-1, D-1SC)	same	same	-	+\$100
	add "-D1SC" to part #	With D-1SC ProCharger (replacing P-1SC-1)	tuner kit only	specify	-	+\$250
	add "-D" or "-1" or "-A"	With F-1D, F-1, F-1A ProCharger (replacing P-1SC-1, Stage II only)	tuner kit only	specify	-	+\$775
	add "-94" or "-C" or "-R"	With F-1A-94, F-1C or F-1R (replacing P-1SC-1, Stage II Tuner Kits only)	tuner kit only	-	-	+\$1,100
	add "-94" or "-C" or "-R"	With F-1A-94, F-1C or F-1R (replacing F-1A, Serpentine Race Kits only)	race kit only	-	-	+\$325
	add "-RVR" or "RVB"	Race Bypass Valve Upgrade (specify open or closed valve)	red or black	specify	-	+\$295
add "-800" to part #	800+ HP intercooler system upgrade (Stage II only)	from 3 core	900 hp max	3" tubing	+\$345	

2005-10 MUSTANG V6 (4.0) SYSTEMS AND KITS

Year	Part Number	Description	Boost Options	HP Gain	Intercooler	Price
2005-10	1FQ211-SCI	High Output Intercooled System with P-1SC	6 psi	45-50%	2 core	\$5,649
2005-10	1FQ212-SCI	Stage II Intercooled System with P-1SC	8 psi	55-60%	2 core	\$5,949
2005-10	1FQ202-SCI	Intercooled Tuner Kit with P-1SC	specify	specify	2 core	\$5,199

2005-10 MUSTANG V6 (4.0) OPTIONS	add "-P" to part #	Polished finish for ProCharger (P-series or D-series)	head unit only	-	-	+\$295
	add "-H" to part #	Helical gearset for noise reduction (P-1SC, P-1SC-1, D-1SC)	same	same	-	+\$100
	add "-C" to part #	With P-1SC-1 ProCharger (replacing P-1SC, Stage II and Tuner Kit only)	same as P-1SC	-	-	+\$220
	add "-D1SC" to part #	With D-1SC ProCharger (replacing P-1SC)	tuner kit only	-	-	+\$470
	add "-3C" to part #	3 core intercooler system upgrade	from 2 core	-	3" tubing	+\$345

SPECIFICATIONS (2005-10 MUSTANG)

2005-10 MUSTANG GT (4.6 3V) SPECIFICATIONS

Year	Part Number	OEM HP Rating	HP Gain	Tube Diam	Intercooler Mount	Drive System	Bypass System	Fuel System Upgrade	Fuel Inj. Supplied	Computer/Ignition Modifications	Supercharger Warranty (in months)	CARB E.O.	Foot Notes
2005-10	1FP311-SCI	300	70-75%	2.5-3"	V	stk 6 rib	ProFlow	in-tank pump	39.5 lb/hr	programmer supplied	12, 36 opt. (\$99)	Call	D1, D2
2005-10	1FP301-SCI	300	specify	2.5-3"	V	stk 6 rib	ProFlow	not supplied	No	not supplied	12	-	D1
2005-10	1FP214-SCI	300	70-75%	2.5-3"	V	add'l 8 rib	ProFlow	in-tank pump	39.5 lb/hr	programmer supplied	12, 36 opt. (\$99)	-	D1, D2, D8
2005-10	1FP204-SCI	300	specify	2.5-3"	V	add'l 8 rib	ProFlow	not supplied	No	not supplied	12	-	D1, D8
2005-09	1FP211-SCI	300	70-75%	3"	V	add'l 8 rib	ProFlow	in-tank pump	39.5 lb/hr	programmer supplied	12, 36 opt. (\$99)	-	D1, D2, D6, D7
2005-09	1FP202-SCI	300	specify	3"	V	add'l 8 rib	ProFlow	not supplied	No	not supplied	12	-	D1, D6, D7
2005-09	1FP213-F1	-	specify	3"	V	add'l 12 rib	Race	not supplied	No	not supplied	12	-	D1, D3, D4, D5, D7

2005-10 MUSTANG V6 (4.0) SPECIFICATIONS

Year	Part Number	OEM HP Rating	HP Gain	Tube Diam	Intercooler Mount	Drive System	Bypass System	Fuel System Upgrade	Fuel Inj. Supplied	Computer/Ignition Modifications	Supercharger Warranty (in months)	CARB E.O.	Foot Notes
2005-10	1FQ211-SCI	220	45-50%	3"	V	stk 6 rib	ProFlow	not required	not required	programmer supplied	12, 36 opt. (\$99)	-	D1, D2, D9, D10
2005-10	1FQ212-SCI	220	55-60%	3"	V	stk 6 rib	ProFlow	not required	39.5 lb/hr	programmer supplied	12, 36 opt. (\$99)	-	D1, D2, D9, D10
2005-10	1FQ202-SCI	220	specify	3"	V	stk 6 rib	ProFlow	not required	No	not supplied	12	-	D1, D10

FORD AUTOMOTIVE FOOTNOTES (specific to above applications):

- D1) Model year must be specified
- D2) Due to variability among OEM computers, and the prevalence of custom modifications, dyno tuning may be required; stock vehicles with cat-back exhaust systems may also require custom tuning
- D3) Modified engines only
- D4) Inner fender modification required
- D5) Requires use of ATI Performance Products aftermarket balancer, part #918039 (not included - specify hardened hub)
- D6) System ships in extra large box
- D7) 800+ hp intercooler may require trimming of plastic bumper cover (behind bumper, not visible)
- D8) Fog lights may need to be removed on 2010 Mustang GT's
- D9) ECM code required
- D10) Special order kit: order form and non-refundable deposit required at time of order—may require additional lead time for processing



1999-04 MUSTANG GT AND 2001 BULLITT (4.6 2V) SYSTEMS AND KITS

Year	Part Number	Description	Boost Options	HP Gain	Intercooler	Price
1999-04	1FE212-SCI	High Output Intercooled System with P-1SC	8 psi	55-60%	2 core	\$5,949
1999-04	1FE202-SCI	High Output Intercooled Tuner Kit with P-1SC	specify	specify	2 core	\$5,049
1999-04	1FE211-SCI	Stage II Intercooled System with P-1SC	8 psi	60-65%	3 core	\$6,349
1999-04	1FE201-SCI	Stage II Intercooled Tuner Kit with P-1SC	specify	specify	3 core	\$5,349
2001 BULLITT	add "-B" to part # above	Same as 1999-04 Mustang GT	see above	see above	see above	see above

2003-04 MUSTANG MACH 1 (4.6 4V) SYSTEMS AND KITS

Year	Part Number	Description	Boost Options	HP Gain	Intercooler	Price
2003-04	1FL212-SCI	Stage II Intercooled System with P-1SC	8 psi	60-65%	3 core	\$6,999
2003-04	1FL202-SCI	Stage II Intercooled Tuner Kit with P-1SC	specify	specify	3 core	\$5,999

1999-04 MUSTANG GT, BULLITT & MACH 1 OPTIONS	add "-P" to part #	Polished finish for ProCharger (P-series or D-series, head unit only)	satin standard	-	-	+\$295
	add "-P" to part #	Polished finish for ProCharger (F-series, 9" or 9.75" housing)	satin standard	-	-	+\$325
	add "-H" to part #	Helical gearset for noise reduction (P-1SC, D-1SC)	same	same	-	+\$100
	add "-D1SC" to part #	With D-1SC ProCharger (replacing P-1SC)	tuner kit only	specify	-	+\$470
	add "-D" or "-1" or "-A"	With F-1D, F-1, F-1A (replacing P-1SC)	tuner kit only	specify	-	+\$1,000
	add "-RVR" or "RVB"	Race Bypass Valve Upgrade (specify open or closed valve)	red or black	specify	-	+\$295
	add "-3C" to part #	3 core intercooler system upgrade	from 2 core	825 hp max	3" tubing	+\$345
add "-SM" to part #	Sheet metal 3 core race intercooler upgrade	from 3 core	950 hp max	3" tubing	+\$285	

1996-98 MUSTANG GT (4.6 2V) SYSTEMS AND KITS

Year	Part Number	Description	Boost Options	HP Gain	Intercooler	Price
1996-98	1FD211-10I	High Output Intercooled System with P-1SC	8, 10 psi	55-70%	2 core	\$5,449
1996-98	1FD201-SCI	High Output Intercooled Tuner Kit with P-1SC	specify	specify	2 core	\$5,199
1996-98	1FD212-SCI	Stage II Intercooled System with P-1SC	8, 10, 12 psi	60-80%	3 core	\$5,749
1996-98	1FD202-SCI	Stage II Intercooled Tuner Kit with P-1SC	specify	specify	3 core	\$5,499

1996-98 MUSTANG GT OPTIONS	add "-P" to part #	Polished finish for ProCharger (P-series or D-series, head unit only)	satin standard	-	-	+\$295
	add "-H" to part #	Helical gearset for noise reduction (P-1SC, D-1SC)	same	same	-	+\$100
	add "-D1SC" to part #	With D-1SC ProCharger (replacing P-1SC)	tuner kit only	specify	-	+\$470
	add "-3C" to part #	3 core intercooler system upgrade	from 2 core	825 hp max	3" tubing	+\$345
	add "-SM" to part #	Sheet metal 3 core race intercooler upgrade	from 3 core	950 hp max	3" tubing	+\$285

1994-04 MUSTANG V6 (3.8, 3.9) SYSTEMS AND KITS

Year	Part Number	Description	Boost Options	HP Gain	Intercooler	Price
1999-03	1FI202-SCI	Stage II Intercooled System with P-1SC	9, 11 psi	60-80%	2 core	\$5,499
1999-04	1FI200-SCI	Intercooled Tuner Kit with P-1SC	specify	specify	2 core	\$4,949
1994-98	1FJ212-SCI	High Output Intercooled System with P-1SC	11 psi	75-80%	2 core	\$4,799
1994-98	1FJ202-SCI	High Output Intercooled Tuner Kit with P-1SC	specify	specify	2 core	\$4,549

1994-04 MUSTANG V6 (3.8, 3.9)	add "-P" to part #	Polished finish for ProCharger (P-series or D-series, head unit only)	satin standard	-	-	+\$295
	add "-H" to part #	Helical gearset for noise reduction (P-1SC, D-1SC)	same	same	-	+\$100
	add "-D1SC" to part #	With D-1SC ProCharger (replacing P-1SC)	tuner kit only	-	-	+\$470
	add "-3C" to part #	3 core intercooler system upgrade	from 2 core	825 hp max	3" tubing	+\$345

SPECIFICATIONS (1994-04 MUSTANG)

1999-04 MUSTANG GT AND 2001 BULLITT (4.6 2V) SPECIFICATIONS

Year	Part Number	OEM HP Rating	HP Gain	Tube Diam	IC Mount	Drive System	Bypass System	Fuel System Upgrade	Fuel Inj. Supplied	Computer/Ignition Modifications	Supercharger Warranty (in months)	CARB E.O.	Foot Notes
1999-04	1FE212-SCI	260	55-60%	3"	V	stk 6 rib	ProFlow	not required	39.5 lb/hr	programmer supplied	12, 36 opt. (\$99)	D-365-5	E1, E5, E14
1999-04	1FE202-SCI	260	specify	3"	V	stk 6 rib	ProFlow	not supplied	No	not supplied	12	-	E1, E6, E14
1999-04	1FE211-SCI	260	60-65%	3"	V	stk 6 rib	ProFlow	in-tank pump	39.5 lb/hr	programmer supplied	12, 36 opt. (\$99)	-	E1, E3, E5, E14
1999-04	1FE201-SCI	260	specify	3"	V	stk 6 rib	ProFlow	not supplied	No	not supplied	12	-	E1, E6, E14
2001	BULLITT	265	55-60%	3"	V	stk 6 rib	ProFlow	As above	As above	As above	As above	D-365-5	As Above

2003-04 MUSTANG MACH 1 (4.6 4V) SPECIFICATIONS

Year	Part Number	OEM HP Rating	HP Gain	Tube Diam	IC Mount	Drive System	Bypass System	Fuel System Upgrade	Fuel Inj. Supplied	Computer/Ignition Modifications	Supercharger Warranty (in months)	CARB E.O.	Foot Notes
2003-04	1FL212-SCI	300	60-65%	3"	V	stk 6 rib	ProFlow	in-tank pump	39.5 lb/hr	programmer supplied	12, 36 opt. (\$99)	Call	E1, E3, E5
2003-04	1FL202-SCI	300	specify	3"	V	stk 6 rib	ProFlow	not supplied	No	not supplied	12	-	E1

1996-98 MUSTANG GT (4.6 2V) SPECIFICATIONS

Year	Part Number	OEM HP Rating	HP Gain	Tube Diam	IC Mount	Drive System	Bypass System	Fuel System Upgrade	Fuel Inj. Supplied	Computer/Ignition Modifications	Supercharger Warranty (in months)	CARB E.O.	Foot Notes
1996-98	1FD211-101	215-225	55-70%	3"	V	stk 6 rib	ProFlow	ProPump, FMU	not required	not required	12, 36 opt. (\$99) @ 8 psi	D-365-3 (10 psi)	E1, E5, E13
1996-98	1FD201-SCI	215-225	55-70%	3"	V	stk 6 rib	ProFlow	not supplied	not required	not required	12	-	E1, E5, E13
1996-98	1FD212-SCI	215-225	60-80%	3"	V	stk 6 rib	ProFlow	ProPump, FMU	No	not required	12, 36 opt. (\$99) @ 8 psi	-	E1, E2 (12 psi), E5, E13
1996-98	1FD202-SCI	215-225	60-80%	3"	V	stk 6 rib	ProFlow	not supplied	No	not required	12	-	E1, E2 (12 psi), E5, E13

1994-04 MUSTANG V6 (3.8, 3.9) SPECIFICATIONS

Year	Part Number	OEM HP Rating	HP Gain	Tube Diam	IC Mount	Drive System	Bypass System	Fuel System Upgrade	Fuel Inj. Supplied	Computer/Ignition Modifications	Supercharger Warranty (in months)	CARB E.O.	Foot Notes
1999-03	1FJ202-SCI	193	60-80%	3"	V	stk 6 rib	ProFlow	in-tank pump	39.5 lb/hr	programmer supplied	12, 36 opt. (\$99) @ 9 psi	-	E1, E3, E9, E13
1999-04	1FI200-SCI	193	specify	3"	V	stk 6 rib	ProFlow	not supplied	not supplied	not supplied	12	-	E1, E9, E12, E13
1994-98	1FJ212-SCI	145	75-80%	3"	V	stk 6 rib	ProFlow	FMU	not required	not required	12, 36 opt. (\$99)	D-365-3	E1, E11, E13
1994-98	1FJ202-SCI	145	75-80%	3"	V	stk 6 rib	ProFlow	not supplied	not required	not required	12	-	E1, E11, E13

FORD AUTOMOTIVE FOOTNOTES (specific to above applications):

- E1) Model year must be specified
- E2) 24 lb/hr fuel injectors required (not supplied)
- E3) Due to variability among OEM computers, and the prevalence of custom modifications, dyno tuning may be required; stock vehicles with cat-back exhaust systems may also require custom tuning
- E5) Aftermarket mass air sensors will require custom tuning
- E6) D-1SC, F-1, F-1A modified motors only (air inlet may require modification)
- E8) 30 lb/hr fuel injectors required (not supplied)
- E9) 1999-01 3.8 Mustangs must specify if car is equipped with ABS/Traction control
- E11) 1994-98 3.8 Mustangs with ABS/Traction control module will require custom relocation of that module
- E12) Tuner kits available for 2004 Mustang V6 3.9L models; custom tuning required
- E13) Special order kit: order form and non-refundable deposit required at time of order—may require additional lead time for processing
- E14) Race valve requires welding



2003-04 COBRA (4.6 4V) KITS

Year	Part Number	Description	Boost Options	Max RWHP	Intercooler	Price
2003-04	1FM202-SC	High Output Tuner Kit with P-1SC-2	10-15 psi	550 rwhp	OEM supplied	\$4,999
2003-04	1FM203-SC	Stage II Tuner Kit with F-1D, F-1, or F-1A (6 rib)	10-20 psi	620 rwhp	OEM supplied	\$5,499
2003-04	1FM204-SC-C	Race Kit with F-1D, F-1, or F-1A (cog drive)	18-30+ psi	750+ rwhp	OEM supplied	\$5,999

2003-04 COBRA (4V)	add "-P" to part #	Polished finish for ProCharger (P-series or D-series)	satin standard	-	-	+\$295
	add "-PI" to part #	Polished finish for sheet metal intake	satin standard	-	-	+\$350
	add "-O" to part #	Omit Cobra intake manifold	-	-	-	-\$659

1999-01 COBRA (4.6 4V) SYSTEMS AND KITS

Year	Part Number	Description	Boost Options	HP Gain	Intercooler	Price
1999-01	1FF211-SCI	High Output Intercooled System with P-1SC	6 psi max	45-50%	2 core	\$6,699
1999-01	1FF201-SCI	High Output Intercooled Tuner Kit with P-1SC	specify	specify	2 core	\$5,799
1999-01	1FF212-SCI	Stage II Intercooled System with P-1SC	8 psi	60-65%	3 core	\$6,999
1999-01	1FF202-SCI	Stage II Intercooled Tuner Kit with P-1SC	specify	specify	3 core	\$5,949

1999-01 COBRA (4V) OPTIONS	add "-P" to part #	Polished finish for ProCharger (P-series or D-series)	satin standard	-	-	+\$295
	add "-H" to part #	Helical gears for noise reduction (P-1SC, D-1SC)	same	same	-	+\$100
	add "-D1SC" to part #	With D-1SC ProCharger (replacing P-1SC)	tuner kit only	specify	-	+\$470
	add "-3C" to part #	3 core intercooler system upgrade (HO system only)	from 2 core	825 hp max	3" tubing	+\$345
	add "-SM" to part #	Sheet metal 3 core race intercooler upgrade	from 3 core	950 hp max	3" tubing	+\$345

1996-98 COBRA (4.6 4V) SYSTEMS AND KITS

Year	Part Number	Description	Boost Options	HP Gain	Intercooler	Price
1996-98	1FC211-10I	HO Intercooled System with P-1SC	6 psi	45-50%	2 core	\$6,499
1996-98	1FC201-SCI	HO Intercooled Tuner Kit with P-1SC	specify	specify	2 core	\$5,699
1996-98	1FC212-SCI	Stage II Intercooled System with P-1SC	8 psi	60-65%	3 core	\$6,799
1996-98	1FC202-SCI	Stage II Intercooled Tuner Kit with P-1SC	specify	specify	3 core	\$5,999

1996-98 COBRA (4V) OPTIONS	add "-P" to part #	Polished finish for ProCharger (P-series or D-series)	satin standard	-	-	+\$295
	add "-H" to part #	Helical gears for noise reduction (P-1SC, D-1SC)	same	same	-	+\$100
	add "-D1SC" to part #	With D-1SC ProCharger (replacing P-1SC)	tuner kit only	specify	-	+\$470
	add "-SM" to part #	Sheet metal 3 core race intercooler upgrade	from 3 core	950 hp max	3" tubing	+\$345

1996-98 COBRA (4.6 4V) RACE KITS

Year	Part Number	Description	Boost Options	HP Gain	Intercooler	Price
1996-98	1FX205-F1A	Serpentine Race Kit with F-1D, F-1, or F-1A (additional 8 rib)	specify	specify	-	\$5,999
1996-98	1FX244-F1C	Coq Race Kit with F-1C or F-1R	specify	specify	-	\$6,599

1996-98 COBRA (4V) RACE KIT OPTIONS	add "-P" to part #	Polished finish for ProCharger (F-series, 9" or 9.75" housing)	satin standard	-	-	+\$325
	add "-P" to part #	Polished finish for ProCharger (10.5" housing)	satin standard	-	-	+\$375
	add "-C" or "-R" to part #	With F-1C or F-1R ProCharger (replacing F-1D, F-1, F-1A)	specify	specify	-	+\$325
	add "-F2" to part #	With F-2 ProCharger (replacing F-1C, F-1R)	cog kit only	specify	-	+\$975
	AI045A-001	Sheet metal 3 core race intercooler (1300 hp)	-	3.5" in/outlet	-	+\$1,586
	WI1005A-001	Air/water intercooler (race use only)	-	1,800 hp max	-	+\$2,199

SPECIFICATIONS (1996-04 COBRA)

2003-04 COBRA (4.6 4V) SPECIFICATIONS

Year	Part Number	OEM HP Rating	HP Gain	Tube Diam	Intercooler Mount	Drive System	Bypass System	Fuel System Upgrade	Fuel Inj. Supplied	Computer/Ignition Modifications	Supercharger Warranty (in months)	CARB E.O.	Foot Notes
2003-04	1FM202-SC	390	specify	-	-	stk 6 rib	ProFlow	not required	No	not supplied	12	-	F1, F10
2003-04	1FM203-SC	390	specify	-	-	stk 6 rib	Race	not supplied	No	not supplied	12	-	F1, F10
2003-04	1FM204-SC-C	390	specify	-	-	cog	Race	not supplied	No	not supplied	Limited	-	F1, F9, F10

1999-01 COBRA (4.6 4V) SPECIFICATIONS

Year	Part Number	OEM HP Rating	HP Gain	Tube Diam	Intercooler Mount	Drive System	Bypass System	Fuel System Upgrade	Fuel Inj. Supplied	Computer/Ignition Modifications	Supercharger Warranty (in months)	CARB E.O.	Foot Notes
1999-01	1FF211-SCI	320	45-50%	3"	V	stk 6 rib	ProFlow	not required	39.5 lb/hr	programmer supplied	12, 36 opt. (\$99)	-	F1, F2, F3
1999-01	1FF201-SCI	320	specify	3"	V	stk 6 rib	ProFlow	not supplied	No	not supplied	12	-	F1, F3, F4
1999-01	1FF212-SCI	320	60-65%	3"	V	stk 6 rib	ProFlow	in-tank pump	39.5 lb/hr	programmer supplied	12, 36 opt. (\$99)	Call	F1, F2, F4
1999-01	1FF202-SCI	320	specify	3"	V	stk 6 rib	ProFlow	not supplied	No	not supplied	12	-	F1, F4

1996-98 COBRA (4.6 4V) SPECIFICATIONS

Year	Part Number	OEM HP Rating	HP Gain	Tube Diam	Intercooler Mount	Drive System	Bypass System	Fuel System Upgrade	Fuel Inj. Supplied	Computer/Ignition Modifications	Supercharger Warranty (in months)	CARB E.O.	Foot Notes
1996-98	1FC211-10I	305	45-50%	3"	V	stk 6 rib	ProFlow	ProPump, FMU	No	programmer supplied	12, 36 opt. (\$99)	D-365-3	F1, F5, F10
1996-98	1FC201-SCI	305	specify	3"	V	stk 6 rib	ProFlow	not supplied	No	not supplied	12	-	F1, F10
1996-98	1FC212-SCI	305	60-65%	3"	V	stk 6 rib	ProFlow	ProPump, FMU	No	programmer supplied	12, 36 opt. (\$99)	-	F1, F2, F5, F10
1996-98	1FC202-SCI	305	specify	3"	V	stk 6 rib	ProFlow	not supplied	No	not supplied	12	-	F1, F10

1996-98 COBRA (4.6 4V) RACE SPECIFICATIONS

Year	Part Number	OEM HP Rating	HP Gain	Tube Diam	Intercooler Mount	Drive System	Bypass System	Fuel System Upgrade	Fuel Inj. Supplied	Computer/Ignition Modifications	Supercharger Warranty (in months)	CARB E.O.	Foot Notes
1996-98	1FX205-F1A	n/a	specify	-	-	add'l 8 rib	Race	not supplied	No	not supplied	12	-	F6, F8
1996-98	1FX244-F1C	n/a	specify	-	-	cog	Race	not supplied	No	not supplied	Limited	-	F1, F6, F7, F8, F10

FORD AUTOMOTIVE FOOTNOTES (specific to above applications):

- F1) Model year must be specified
- F2) Due to variability among OEM computers, and the prevalence of custom modifications, dyno tuning may be required
- F3) HO Systems and Tuner Kits for 1996-01 Cobras require a cut-down impeller, which limits max boost to 8 psi on stock motors
- F4) 1999-01 model years with over 10 psi boost require Ford Lightning (flange-style) MAF (not supplied)
- F5) 30 lb/hr fuel injectors required (not supplied)
- F6) Modified motors only
- F7) May require cooling system and air conditioning system modifications
- F8) ATI Performance Products aftermarket balancer required, part #918036 (not included - specify hardened hub)
- F9) Battery relocation required (trunk relocation kit supplied)
- F10) Special order kit: order form and non-refundable deposit required at time of order—may require additional lead time for processing



1994-95 MUSTANG AND COBRA (5.0) SYSTEMS AND KITS

Year	Part Number	Description	Boost Options	HP Gain	Intercooler	Price
1994-95	1FB100-091 / 111 / 141	High Output Intercooled System with P-1SC	9, 11, 14 psi	60-85%	2 core	\$5,399
1994-95	1FB202-SCI	High Output Intercooled Tuner Kit with P-1SC	specify	specify	2 core	\$5,149
1994-95	1FB324-D1SC	Stage II Intercooled System with D-1SC	15-22 psi	85%+	3 core	\$6,099
1994-95	1FB012-SC1	High Output Kit with P-1SC	specify	specify	-	\$4,299

1994-95 MUSTANG & COBRA (5.0) OPTIONS	add "-P" to part #	Polished finish for ProCharger (P-series or D-series)	satin standard	-	-	+\$295
	add "-P" to part #	Polished finish for ProCharger (F-series, 9" or 9.75" housing)	satin standard	-	-	+\$325
	add "-H" to part #	Helical gearset for noise reduction (P-1SC, D-1SC)	same	same	-	+\$100
	add "-P1SC1" to part #	With P-1SC-1 ProCharger (replacing P-1SC)	specify	specify	-	+\$220
	add "-P1X" to part #	With P-1X ProCharger (replacing P-1SC)	specify	specify	-	+\$420
	add "-D1SC" to part #	With D-1SC ProCharger (replacing P-1SC)	specify	specify	-	+\$470
	add "-D" or "-1" or "-A"	With F-1D, F-1, F-1A ProCharger (replacing D-1SC, Stage II only)	specify	specify	-	+\$540
	add "-RVR" or "RVB"	Race Bypass Valve Upgrade (specify open or closed valve)	red or black	specify	-	+\$295
	add "-3C" to part #	3 core intercooler system upgrade	from 2 core	825 hp max	3" tubing	+\$345
	add "-SM" to part #	Sheet metal 3 core race intercooler upgrade	from 3 core	950 hp max	3" tubing	+\$285
add "-OF" to part #	Omit FMU (from Stage II)	-	-	-	-\$88	
add "-OP" to part #	Omit in-line fuel pump (from Stage II)	-	-	-	-\$98	

1986-93 MUSTANG AND COBRA (5.0) SYSTEMS AND KITS

Year	Part Number	Description	Boost Options	HP Gain	Intercooler	Price
1986-93	1FA100-091 / 111 / 141	High Output Intercooled System with P-1SC (8 rib)	9, 11, 14 psi	60-85%	2 core	\$5,299
1986-93	1FA202-SCI	High Output Intercooled Tuner Kit with P-1SC (8 rib)	specify	specify	2 core	\$5,049
1986-93	1FA324-D1SC-8R	Stage II Intercooled System with D-1SC (8 rib)	15-25 psi	85%+	3 core	\$5,999
1986-93	1FA012-SC	High Output Kit with P-1SC	specify	specify	-	\$4,199

1986-93 MUSTANG & COBRA (5.0) OPTIONS	add "-B" or "-P" to part #	Black or Polished finish for ProCharger (P-series or D-series)	satin standard	-	-	+\$295
	add "-B" or "-P" to part #	Black or Polished finish for ProCharger (F-series, 9" or 9.75" housing)	satin standard	-	-	+\$325
	add "-H" to part #	Helical gearset for noise reduction (P-1SC, D-1SC)	same	same	-	+\$100
	add "-P1SC1" to part #	With P-1SC-1 ProCharger (replacing P-1SC)	specify	specify	-	+\$220
	add "-P1X" to part #	With P-1X ProCharger (replacing P-1SC)	specify	specify	-	+\$420
	add "-D1SC" to part #	With D-1SC ProCharger (replacing P-1SC)	specify	specify	-	+\$470
	add "-D" or "-1" or "-A"	With F-1D, F-1, F-1A ProCharger (replacing D-1SC)	specify	specify	-	+\$540
	add "-12R" to part #	12 rib drive system upgrade (Stage II only)	specify	specify	-	+\$230
	AV006A-003	Bullet bypass valve kit (from ProFlow, HO Intercooled Systems/Kits only)	-	-	-	+\$105
	add "-3C" to part #	3 core intercooler system upgrade	from 2 core	825 hp max	3" tubing	+\$345
	add "-THF" to part #	Twin Highflow intercooler upgrade	from 3 core	850 hp max	2.5-3" tubing	+\$285
	add "-SM" to part #	Sheet metal 3 core race intercooler upgrade	from 3 core	950 hp max	3" tubing	+\$285
	add "-OF" to part #	Omit FMU (from Stage II)	-	-	-	-\$88
	add "-OP" to part #	Omit in-line fuel pump (from Stage II)	-	-	-	-\$98
AB003A-010	Alternator relocation kit with power steering (non A/C vehicles)	-	-	-	+\$499	

SPECIFICATIONS (1986-95 MUSTANG AND COBRA)

1994-95 MUSTANG, COBRA (5.0) SPECIFICATIONS

Year	Part Number	OEM HP Rating	HP Gain	Tube Diam	IC Mount	Drive System	Bypass System	Fuel System Upgrade	Fuel Inj. Supplied	Computer/Ignition Modifications	Supercharger Warranty (in months)	CARB E.O.	Foot Notes
1994-95	1FB100-091 / 111 / 141	215/240	60-85%	3"	V	stk 6 rib	ProFlow	ProPump, FMU	not req.	not required	12, 36 opt. (\$99) @ 9 psi	D-365-3	G1, G2, G3, G4, G5, G10
1994-95	1FB202-SCI	215/240	60-85%	3"	V	stk 6 rib	ProFlow	not supplied	not req.	not required	12	-	G1, G2, G3, G4, G5, G10
1994-95	1FB324-D1SC	215/240	85%+	3"	V	stk 6 rib	ProFlow	ProPump, FMU	No	not required	12	-	G1, G2, G3, G4, G5, G10
1994-95	1FB012-SC1	215/240	specify	-	-	stk 6 rib	ProFlow	FMU	No	not supplied	12	-	G1, G2, G3, G4, G5, G10

1986-93 MUSTANG, COBRA (5.0) SPECIFICATIONS

Year	Part Number	OEM HP Rating	HP Gain	Tube Diam	IC Mount	Drive System	Bypass System	Fuel System Upgrade	Fuel Inj. Supplied	Computer/Ignition Modifications	Supercharger Warranty (in months)	CARB E.O.	Foot Notes
1986-93	1FA100-091 / 111 / 141	205-235	60-85%	3"	V / H	add'l 8 rib	ProFlow	ProPump, FMU	not req.	not required	12, 36 opt. (\$99) @ 9 psi	D-365-3	G1, G2, G6, G9, G12
1986-93	1FA202-SCI	205-235	60-85%	3"	V / H	add'l 8 rib	ProFlow	not supplied	not req.	not required	12	-	G1, G2, G6, G9, G12
1986-93	1FA324-D1SC-8R	205-235	85%+	3"	V / H	add'l 8 rib	ProFlow	ProPump, FMU	No	not required	12	-	G1, G2, G6, G7, G9, G11, G12
1986-93	1FA012-SC	205-235	specify	3"	-	add'l 8 rib	ProFlow	FMU	No	not supplied	12	-	G1, G2, G8, G9, G12

FORD AUTOMOTIVE FOOTNOTES (specific to above applications):

- G1) Model year must be specified
- G2) Standard ProCharger bracket requires factory a/c and p/s
- G3) Specify stock or bullet-style MAF flange
- G4) Battery relocation required (trunk relocation kit supplied)
- G5) Cobra balancer must be replaced with GT balancer, Ford part #F4ZZ6A312A (not supplied)
- G6) GT models can have either vertical or horizontal intercooler mounting; horizontal intercooler or Twin Highflow mounting recommended for LX models; vertical mounting possible with modifications; vertical mounting or Twin Highflow recommended for all lowered vehicles.
- G7) Inner fender modification may be required
- G8) Specify stock or cowl hood (additional charge for stock hood—requires alternate tubing)
- G9) For speed density models (most 1986-88) MAF conversion is recommended (not supplied)
- G10) Special order kit: order form and non-refundable deposit required at time of order—may require additional lead time for processing
- G11) 12-rib kits may require modifications/trimming.
- G12) Non A/C vehicles require power steering relocation kit (AB003A-010)



CARBURETED AND AFTERMARKET EFI FORD SB SERPENTINE KITS (WINDSOR/YATES BASED, 85-93 ACCESSORIES)

Year	Part Number	Description	Boost Options	HP Gain	Intercooler	Price
1985-93	1FX012-P1SC	High Output with P-1SC (8 rib)	specify	specify	-	\$4,199
1985-93	1FX212-P1SC-I	High Output Intercooled with P-1SC (8 rib)	specify	specify	2 core (550hp)	\$5,199
1985-93	1FX013-P1SC2	High Output Kit with P-1SC-2 (8 rib)	specify	specify	-	\$4,399
1985-93	1FX022-D1SC	High Output with D-1SC (12 rib)	specify	specify	-	\$4,799
1985-93	1FX222-D1SC-I	High Output Intercooled with D-1SC (12 rib)	specify	specify	3 core (825hp)	\$5,899
1985-93	1FX024-F1A94/F1C/F1R	8 rib Race Kit with F-1A-94, F-1C or F-1R (EFI Renegade)	specify	specify	-	\$5,849
1985-93	1FX124-F1D/F1F/F1A	High Output with F-1D, F-1, or F-1A (12 rib)	specify	specify	-	\$5,799
1985-93	1FX324-F1D-I/F1F/F1A-I	High Output Intercooled with F-1D, F-1, or F-1A (12 rib)	specify	specify	Sht mtl 3C (950hp)	\$7,199
1985-93	1FX022-F1A94/F1C/F1R	High Output with F-1A-94, F-1C or F-1R (12 rib)	specify	specify	-	\$6,249
1985-93	1FX124-F1A94-I/F1C-I/F1R-I	High Output Intercooled with F-1A-94, F-1C or F-1R (12 rib)	specify	specify	Sht mtl 3C (1050hp)	\$7,449

1964^{1/2}-66 MUSTANG AND EARLY FORD (289, 302, 351 V8) KITS

Year	Part Number	Description	Boost Options	HP Gain	Intercooler	Price
1964.5-66	1FX400-P1SC	High Output with P-1SC (8 rib)	specify	specify	-	\$4,299
1964.5-66	1FX400-P1SC-I	High Output Intercooled with P-1SC (8 rib)	specify	specify	2 core (550hp)	\$5,299

CARB & AFTERMARKET EFI FORD SB SERPENTINE KIT OPTIONS	add "-B" or "-P" to part #	Black or Polished finish for ProCharger (P-series or D-series)	satin standard	-	-	+\$295
	add "-B" or "-P" to part #	Black or Polished finish for ProCharger (F-series 9"9.75" housing)	satin standard	-	-	+\$325
	add "-BB" or "-PB" to part #	Black or Polished finish for supercharger bracket	satin standard	-	-	+\$250
	add "-BC" or "-PC" to part #	Black or Polished finish for carburetor bonnet	satin standard	-	-	+\$90
	add "-BPPB" or "-PPB" to part #	Black or Polished finish for Power Steering Bracket	satin standard	-	-	+\$159
	add "-BAB" or "-PAB" to part #	Black or Polished finish for Alternator Bracket	satin standard	-	-	+\$152
	add "-H" to part #	Helical gearset for noise reduction (P-1SC, D-1SC)	same	same	-	+\$100
	add "-P1X" to part #	With P-1X ProCharger (replacing P-1SC)	same	add'l 10-15+ hp	-	+\$420
	add "-D1X" to part #	With D-1X ProCharger (replacing P-1SC)	tuner kit only	specify	-	+\$645
	add "-D1SC" to part #	With D-1SC ProCharger (replacing P-1SC)	-	specify	-	+\$470
	add "-D1X" to part #	With D-1X ProCharger (replacing D-1SC)	tuner kit only	specify	-	+\$175
	add "-D" or "-1" or "-A"	With F-1D, F-1, F-1A ProCharger (replacing P-1SC)	-	specify	-	+\$1,000
	add "-94"	With F-1A-94 ProCharger (replacing P-1SC)	-	-	-	+\$1,340
	3FXSS-003	ProFlow bypass valve kit	-	-	-	+\$244
	AV006A-003	Bullet bypass valve kit	-	-	-	+\$349
	3FASS-00X	Race Bypass Valve, Open or Closed (specify alum. or steel flange)	red or black	-	-	+\$469
	add "-CB" to part #	Competition carb bonnet upgrade	from standard	-	-	+\$35
	AB003A-010	Alternator relocation kit with power steering	satin finish only	-	-	+\$499
	AI003A-001	3 core intercooler (825 hp)	from non-ic kit	3" in/outlet	-	+\$975
	AI003A-002	Sheet metal 3 core race intercooler (950 hp)	from non-ic kit	3" in/outlet	-	+\$1,170
	AI003A-005	Sheet metal 3 core race intercooler (1050 hp)	from non-ic kit	3.5" in/outlet	-	+\$1,350
	AI045A-001	Sheet metal 3 core race intercooler (1300 hp)	from non-ic kit	3.5" in/outlet	-	+\$1,586
	AI003A-001	3 Core Intercooler Upgrade (825 hp)	from 2 core	3" in/outlet	-	+\$200
	AI003A-002	Air-to-Air Race Intercooler Upgrade (950 hp)	from 2 core	3" in/outlet	-	+\$395
	3FAAT-003	Alternator Bracket (Requires 1985-93 Alternator) 641/2- 66 Only	-	-	-	+\$150
	FV001I-BST	Boost sensitive fuel pressure regulator (EFI or Carb)	-	-	-	+\$259
	FV002I-BST	Boost sensitive fuel pressure regulator (Carb only, 1000hp capable)	-	-	-	+\$279
FP001I-002	ProPump fuel pump 700 hp	-	-	-	+\$179	
FP001I-006	High performance 1000 hp electric fuel pump	-	-	-	+\$399	

FOR COYOTE & GODZILLA ENGINE SWAP KITS, SEE PAGE 22

SPECIFICATIONS

(CARB AND AFTERMARKET EFI SMALL BLOCK 1964^{1/2} - 73 EARLY FORD)

CARBURETED, AFTERMARKET EFI FORD SB SERPENTINE KITS (WINDSOR/YATES BASED, 1985-93 MUSTANG ACCESSORIES)

Year	Part Number	HP Gain	Tube Diam	Carb Hat	Drive System	Bypass Valve	Alternator Relocation Kit	Alternator with P/S Relocation Kit	Tubing Supplied	SC Warranty (in months)	Foot Notes
1985-93	1FX012-P1SC	specify	-	Low profile	add'l 8 rib	Sold separately	Optional	Optional	-	12	H1, H5, H6, H7
1985-93	1FX212-P1SC-I	specify	3"	Standard	add'l 8 rib	ProFlow	Optional	Optional	Yes	12	H1, H2, H5, H6, H7
1985-93	1FX013-P1SC2	specify	-	Low profile	add'l 8 rib	Sold separately	Optional	Optional	-	12	H1, H5, H6, H7
1985-93	1FX014-D1	specify	-	Standard	add'l 12 rib	Sold separately	Optional	Optional	-	12	H1, H5, H6, H7
1985-93	1FX022-D1SC	specify	-	Standard	add'l 12 rib	Sold separately	Optional	Optional	-	12	H1, H5, H6, H7
1985-93	1FX222-D1SC-I	specify	3"	Standard	add'l 12 rib	ProFlow	Optional	Optional	Yes	12	H1, H2, H5, H6, H7
1985-93	1FX024-F1A94/F1C/F1R	specify	-	-	add'l 8 rib	Race Valve	N/A	N/A	-	12	H1, H4, H5, H6, H7
1985-93	1FX124-F1D/F1F/F1A	specify	-	Standard	add'l 12 rib	Race Valve	Optional	Optional	-	12	H1, H5, H6, H7
1985-93	1FX324-F1D-I/F1-I/F1A-I	specify	3"	Standard	add'l 12 rib	Race Valve	Optional	Optional	Yes	12	H1, H2, H5, H6, H7
1985-93	1FX022-F1A94/F1C/F1R	specify	-	Standard	add'l 12 rib	Race Valve	Optional	Optional	-	12	H1, H5, H6, H7
1985-93	1FX124-F1A94-I/F1C-I/F1R-I	specify	3.5"	Standard	add'l 12 rib	Race Valve	Optional	Optional	Yes	12	H1, H2, H3, H5, H6, H7

1964^{1/2}-73 MUSTANG AND EARLY FORD (289, 302, 351 V8) SPECIFICATIONS

Year	Part Number	HP Gain	Tube Diam	Intercooler Mount	Drive System	Bypass Valve	Power Steering Bracket	Alternator Bracket	Tubing Supplied	SC Warranty (in months)	Foot Notes
1964.5-66	1FX400-P1SC	specify	3"	-	add'l 8 rib	ProFlow	Optional	Optional	-	12	H8, H9, H10
1964.5-66	1FX400-P1SC-I	specify	-	V	add'l 8 rib	ProFlow	Optional	Optional	Yes	12	H8, H9, H10

Call for '69-73 Mustang, '66-73 Fairlane, Maverick, Comet, Falcon, Torino.

FORD AUTOMOTIVE FOOTNOTES (specific to above applications):

- H1) Carbureted systems require Holley 4150 series or similar blow-through carburetor (sold separately by others) and fuel system upgrade (sold separately by ProCharger and others)
- H2) Specify Universal or Fox Body intercooler kit and tubing
- H3) Universal intercooler tubing kit, not designed for a specific vehicle
- H4) ProCharger pulleys do not line up with factory (OEM) 6-rib accessory pulleys—realignment of factory accessories is required
- H5) Specify engine deck height
- H6) Specify Windsor or Yates cylinder heads
- H7) Specify with or without P/S; does not work with A/C
- H8) Factory balancer required
- H9) Alternator bracket option requires 1986-93 Fox Body alternator
- H10) Power steering pump bracket option requires 1986-93 Fox Body p/s pump



CARBURETED AND AFTERMARKET EFI FORD SB COG RACE KITS (1985-93 MUSTANG)

Year	Part Number	Description	Boost Options	HP Gain	Intercooler	Price
1985-93	1FX224-F1D/F1/F1A	Cog Race Kit with F-1D, F-1, F-1A	specify	specify	-	\$5,999
1985-93	1FX234-F1D-I/F1-I/F1A-I	Intercooled Cog Race Kit with F-1D, F-1, or F-1A	specify	specify	Sht mtl 3C (950hp)	\$7,299
1985-93	1FX224-F1C/F1R	Cog Race Kit with F-1C, F-1R	specify	specify	-	\$6,299
1985-93	1FX234-F1C-I/F1R-I	Intercooled Cog Race Kit with F-1C or F-1R	specify	specify	Sht mtl 3C (1050hp)	\$7,599
1985-93	1FX224-F1X	Cog Race Kit with F-1X	specify	specify	-	\$6,749
1985-93	1FX234-F1X-I	Intercooled Cog Race Kit with F-1X	specify	specify	Sht mtl 3C (1300hp)	\$8,199
1985-93	1FX224-F2	Cog Race Kit with F-2	specify	specify	-	\$7,199
1985-93	1FX234-F2-I	Intercooled Cog Race Kit with F-2	specify	specify	Sht mtl 3C (1300hp)	\$8,649
1985-93	1FX224-F3A-spec	Cog Race Kit with F-3R-121	specify	specify	-	\$7,899
1985-93	1FX224-F3R-spec	Cog Race Kit with F-3R-13N (specify 130 or 136)	specify	specify	-	\$8,199
1985-93	1FX223-F1R	Reverse Race Kit with F-1R	specify	specify	-	\$6,699
1985-93	1FX223-F1X	Reverse Race Kit with F-1X	specify	specify	-	\$7,199
1985-93	1FX223-F2R	Reverse Race Kit with F-2	specify	specify	-	\$7,499
1985-93	1FX223-F3AR-spec	Reverse Race Kit with F-3R-121	specify	specify	-	\$8,649
1985-93	1FX223-F3RR-spec	Reverse Race Kit with F-3R-13N (specify 130 or 136)	specify	specify	-	\$8,949

1985-93 CARB & AFTERMARKET EFI FORD SB COG RACE KIT OPTIONS	add "B" or "P" to part #	Black or Polished finish for ProCharger (P-series or D-series)	satin standard	-	-	+\$295
	add "B" or "P" to part #	Black or Polished finish for ProCharger (F-series 9"9.75" housing)	satin standard	-	-	+\$325
	add "B" or "P" to part #	Black or Polished finish for ProCharger (10.5" housing)	satin standard	-	-	+\$375
	add "B" or "P" to part #	Black or Polished finish for ProCharger (12" housing)	satin standard	-	-	+\$425
	add "BB" or "PB" to part #	Black or Polished finish for supercharger bracket	satin standard	-	-	+\$250
	add "BC" or "PC" to part #	Black or Polished finish for carburetor bonnet	satin standard	-	-	+\$90
	add-A91 to part #	With F-1A-91 ProCharger (from F-1D, F-1, F-1A kit)	specify	specify	-	+\$325
	add-A94 to part #	With F-1A-94 ProCharger (from F-1D, F-1, F-1A kit)	specify	specify	-	+\$325
	add "-112" to part #	With F-1X-12/F-3R-112 ProCharger (replacing F-3R-121)	specify	specify	-	-\$300
	3FASS-00X	Race Bypass Valve, Open or Closed (specify alum. or steel flange)	red or black	-	-	included
	add "-CB" to part #	Competition carb bonnet upgrade	from std.	-	-	+\$35
	AM001A-001	Competition carburetor bonnet	-	-	-	+\$240
	3FAAT-002	Alternator Relocation Kit	satin finish only	-	-	+\$289
	AI003A-002	Sheet metal 3 core race intercooler (950 hp)	from non-ic kit	3" in/outlet	-	+\$1,170
	AI003A-005	Sheet metal 3 core race intercooler (1050 hp)	from non-ic kit	3.5" in/outlet	-	+\$1,350
	AI045A-001	Sheet metal 3 core race intercooler (1300 hp)	from non-ic kit	3.5" in/outlet	-	+\$1,586
	AI006A-001	Sheet metal 3 core race intercooler (1550 hp)	from non-ic kit	4" in/outlet	-	+\$2,075
	WI1005A-001	Air/water race intercooler (race use only)	-	1,800 hp max	-	+\$2,199
	WI1005A-002	Air/water race intercooler (race use only)	-	2,500+ hp max	-	+\$2,699
	FV002I-BST	Boost sensitive fuel pressure regulator (Carb only, 1000hp capable)	-	-	-	+\$279
FP001I-006	High Performance 1000 hp electric fuel pump	-	-	-	+\$399	

FOR COYOTE & GODZILLA ENGINE SWAP KITS, SEE PAGE 22
FOR CRANKDRIVE, SEE PAGE 86

SPECIFICATIONS (CARB AND AFTERMARKET EFI SMALL BLOCK)

CARBURETED, AFTERMARKET EFI FORD SB COG RACE KITS (1985-93 MUSTANG ACCESSORIES)

Year	Part Number	HP Gain	Tube Diam	Carb Hat	Drive System	Bypass Valve	Alternator Relocation Kit	Alternator with P/S Relocation Kit	Tubing Supplied	SC Warranty (in months)	Foot Notes
1985-93	1FX224-F1D/F1/F1A	specify	-	Standard	8 x 50 mm Cog	Race Valve	Optional	N/A	-	Limited	11, 12, 15, 16
1985-93	1FX234-F1D-I/F1-I/F1A-I	specify	3"	Standard	8 x 50 mm Cog	Race Valve	Optional	N/A	Yes	Limited	11, 12, 13, 15, 16
1985-93	1FX224-F1C/F1R	specify	-	Standard	8 x 50 mm Cog	Race Valve	Optional	N/A	-	Limited	11, 12, 15, 16
1985-93	1FX234-F1C-I/F1R-I	specify	3"	Standard	8 x 50 mm Cog	Race Valve	Optional	N/A	Yes	Limited	11, 12, 14, 15, 16
1985-93	1FX224-F1X	specify	-	Standard	8 x 50 mm Cog	Race Valve	Optional	N/A	-	Limited	11, 12, 15, 16
1985-93	1FX234-F1X-I	specify	3"	Standard	8 x 50 mm Cog	Race Valve	Optional	N/A	Yes	Limited	11, 12, 14, 15, 16
1985-93	1FX224-F2	specify	-	Standard	8 x 50 mm Cog	Race Valve	Optional	N/A	-	Limited	11, 12, 15, 16, 17
1985-93	1FX234-F2-I	specify	3.5"	Standard	8 x 50 mm Cog	Race Valve	Optional	N/A	Yes	Limited	11, 12, 14, 15, 16
1985-93	1FX224-F3A-spec	specify	-	-	14 x 55 mm Cog	Race Valve	Optional	N/A	-	Limited	11, 12, 15, 16
1985-93	1FX224-F3R-spec	specify	-	-	14 x 55 mm Cog	Race Valve	Optional	N/A	-	Limited	11, 12, 15, 16, 17
1985-93	1FX223-F1R	specify	-	-	8 x 75 mm Cog	Race Valve	N/A	N/A	-	Limited	11, 15, 16
1985-93	1FX223-F1X	specify	-	-	8 x 75 mm Cog	Race Valve	N/A	N/A	-	Limited	11, 15, 16
1985-93	1FX223-F2R	specify	-	-	8 x 75 mm Cog	Race Valve	N/A	N/A	-	Limited	11, 15, 16
1985-93	1FX223-F3AR-spec	specify	-	-	8 x 75 mm Cog	Race Valve	N/A	N/A	-	Limited	11, 15, 16
1985-93	1FX223-F3RR-spec	specify	-	-	8 x 75 mm Cog	Race Valve	N/A	N/A	-	Limited	11, 15, 16

FORD AUTOMOTIVE FOOTNOTES (specific to above applications):

- 1) Carbureted systems require Holley 4150 series or similar blow-through carburetor (sold separately by others) and fuel system upgrade (sold separately by ProCharger and others)
- 2) Specify universal or Fox Body intercooler kit tubing
- 3) Universal intercooler tubing kit, not designed for a specific vehicle
- 4) ProCharger pulleys do not line up with factory (OEM) 6-rib accessory pulleys—realignment of factory accessories is required
- 5) Specify engine deck height
- 6) Specify Windsor or Yates cylinder heads
- 7) Special order kit: order form and non-refundable deposit required at time of order—may require additional lead time for processing



COYOTE ENGINE SWAP GEN 1 (5.0 4V) KITS

Year	Part Number	Description	Boost Options	HP Gain	Intercooler	Price
specify	1FA400-P1SC1-I	High Output Intercooled Tuner Kit with P-1SC-1	specify	specify	Stage II	\$6,399
specify	1FA400-P1SC1	High Output Tuner Kit with P-1SC-1	specify	specify	-	\$5,199
specify	1FA400-F1-I	Intercooled Cog Race Kit with F-1D, F-1 or F-1A	specify	specify	Air-to-Air Race	\$7,699
specify	1FA400-F1	Cog Race Kit with F-1D, F-1, or F-1A	specify	specify	-	\$6,299
specify	1FA400-F1C-I/F1R-I	Intercooled Cog Race Kit with F-1A-94, F-1C or F-1R	specify	specify	Air-to-Air Race	\$7,999
specify	1FA400-F1C/F1R	Cog Race Kit with F-1A-94, F-1C or F-1R	specify	specify	-	\$6,599

COYOTE ENGINE SWAP GEN 2 & 3 (5.0 4V) KITS

Year	Part Number	Description	Boost Options	HP Gain	Intercooler	Price
specify	1FA500-P1SC1-I	High Output Intercooled Tuner Kit with P-1SC-1	specify	specify	Stage II	\$6,499
specify	1FA500-P1SC1	High Output Tuner Kit with P-1SC-1	specify	specify	-	\$5,299

COYOTE ENGINE SWAP 92-96 F-150 (5.0 4V) KITS

Year	Part Number	Description	Boost Options	HP Gain	Intercooler	Price
specify	1FA700-P1SC1-I	High Output Intercooled Tuner Kit with P-1SC-1	specify	specify	Stage II	\$6,299

(5.0 4V) ENGINE SWAP OPTIONS	add "-B" or "-P" to part #	Black or Polished finish for ProCharger (P-series or D-series)	satin standard	-	-	+\$295
	add "-B" or "-P" to part #	Black or Polished finish for ProCharger (F-series, 9" or 9.75" housing)	satin standard	-	-	+\$325
	add "-BB" or "-PB" to part #	Black or Polished finish for supercharger bracket	satin standard	-	-	+\$250
	add "-H" to part #	Helical gearset for noise reduction (P-1SC-1, P-1X, D-1SC, D-1X)	same	same	-	+\$100
	add "-P1X" to part #	With P-1X ProCharger (replacing P-1SC-1, Systems and Tuner Kits)	same	add'l 10-15+ hp	-	+\$200
	add "-D1SC" to part #	With D-1SC ProCharger (replacing P-1SC-1)	tuner kit only	specify	-	+\$250
	add "-D1X" to part #	With D-1X ProCharger (replacing P-1SC-1, Tuner Kits only)	tuner kit only	specify	-	+\$425
	add "-D" or "-1" or "-A"	With F-1D, F-1, F-1A ProCharger (replacing P-1SC-1)	tuner kit only	specify	-	+\$775
	add "-94" or "C" or "R"	With F-1A-94, F-1C or F-1R ProCharger (replacing P-1SC-1)	tuner kit only	-	-	+\$1,100
	add "-CS" to part #	Coyote Crank Support (Gen 2 & 3 only)	satin standard	-	-	+\$599
	add "-BC" or "-PC" to part #	Black or Polished finish for Crank Support	satin standard	-	-	+\$250
add "-RVR" or "RVB"	Race Bypass Valve Upgrade (specify open or closed valve)	red or black	specify	-	+\$295	
add "-Race" to part #	Air-to-Air Race intercooler upgrade	from Stage II	1000 hp max	3" Tubing	+\$345	
add "-CT" to part #	Coolant Tank Reservoir Replacement Kit	-	-	-	+\$267	

GODZILLA ENGINE SWAP (7.3) KITS

Year	Part Number	Description	Boost Options	HP Gain	Intercooler	Price
specify	1FA600-P1SC1-I	High Output Intercooled Tuner Kit with P-1SC-1	specify	specify	Stage II	\$6,298
specify	1FA600-P1SC1	High Output Tuner Kit with P-1SC-1	specify	specify	-	\$5,098

(7.3) ENGINE SWAP OPTIONS	add "-B" or "-P" to part #	Black or Polished finish for ProCharger (P-series or D-series)	satin standard	-	-	+\$295
	add "-B" or "-P" to part #	Black or Polished finish for ProCharger (F-series, 9" or 9.75" housing)	satin standard	-	-	+\$325
	add "-BB" or "-PB" to part #	Black or Polished finish for supercharger bracket	satin standard	-	-	+\$250
	add "-H" to part #	Helical gearset for noise reduction (P-1SC-1, P-1X, D-1SC, D-1X)	same	same	-	+\$100
	add "-P1X" to part #	With P-1X ProCharger (replacing P-1SC-1, Systems and Tuner Kits)	same	add'l 10-15+ hp	-	+\$200
	add "-D1SC" to part #	With D-1SC ProCharger (replacing P-1SC-1)	tuner kit only	specify	-	+\$250
	add "-D1X" to part #	With D-1X ProCharger (replacing P-1SC-1, Tuner Kits only)	tuner kit only	specify	-	+\$425
	add "-D" or "-1" or "-A"	With F-1D, F-1, F-1A ProCharger (replacing P-1SC-1)	tuner kit only	specify	-	+\$775
	add "-94" or "C" or "R"	With F-1A-94, F-1C or F-1R ProCharger (replacing P-1SC-1)	tuner kit only	-	-	+\$1,100
	add "-F1X" to part #	With F-1X ProCharger (replacing P-1SC-1)	tuner kit only	-	-	+\$1,800
	add "-10R" to part #	10 rib drive system upgrade (HO Tuner Kits only)	from 8 rib	-	-	+\$230
	add "-RVR" or "RVB"	Race Bypass Valve Upgrade (specify open or closed valve)	red or black	specify	-	+\$295
	add "-Race" to part #	Air-to-Air Race intercooler upgrade	from Stage II	1000 hp max	3" Tubing	+\$345
	add "-CT" to part #	Coolant Tank Reservoir Replacement Kit	-	-	-	+\$267

SPECIFICATIONS (COYOTE & GODZILLA ENGINE SWAP KITS)

COYOTE ENGINE SWAP (5.0 4V) SPECIFICATIONS

Year	Part Number	OEM HP Rating	HP Gain	Tube Diam	Drive System	Fuel System Upgrade	Fuel Inj. Supplied	Computer/Ignition Modifications	SC Warranty (in months)	CARB E.O.	Foot Notes
specify	1FA400-P1SC1-I	N/A	specify	3"	add'l 8 rib	not supplied	No	not supplied	12	-	J2, J3, J4, J5
specify	1FA400-P1SC1	N/A	specify	-	add'l 8 rib	not supplied	No	not supplied	12	-	J2, J3, J4, J5
specify	1FA400-F1-I	N/A	specify	3"	cog	not supplied	No	not supplied	Limited	-	J1, J2, J3, J4, J5
specify	1FA400-F1	N/A	specify	-	cog	not supplied	No	not supplied	Limited	-	J1, J2, J3, J4, J5
specify	1FA400-F1C-I/F1R-I	N/A	specify	3"	cog	not supplied	No	not supplied	Limited	-	J1, J2, J3, J4, J5
specify	1FA400-F1C/F1R	N/A	specify	-	cog	not supplied	No	not supplied	Limited	-	J1, J2, J3, J4, J5

COYOTE ENGINE SWAP GEN 2 & 3 (5.0 4V) SPECIFICATIONS - REVERSE MOUNT

Year	Part Number	OEM HP Rating	HP Gain	Tube Diam	Drive System	Fuel System Upgrade	Fuel Inj. Supplied	Computer/Ignition Modifications	SC Warranty (in months)	CARB E.O.	Foot Notes
specify	1FA500-P1SC1-I	N/A	specify	3"	add'l 8 rib	not supplied	No	not supplied	12	-	J2, J3, J5, J6
specify	1FA500-P1SC1	N/A	specify	-	add'l 8 rib	not supplied	No	not supplied	12	-	J2, J3, J5, J6

COYOTE ENGINE SWAP 92-96 F-150 (5.0 4V) KITS

Year	Part Number	OEM HP Rating	HP Gain	Tube Diam	Drive System	Fuel System Upgrade	Fuel Inj. Supplied	Computer/Ignition Modifications	SC Warranty (in months)	CARB E.O.	Foot Notes
specify	1FA700-P1SC1-I	N/A	specify	3"	add'l 8 rib	not supplied	No	not supplied	12	-	J2, J3, J5, J6

GODZILLA ENGINE SWAP (7.3) SPECIFICATIONS

Year	Part Number	OEM HP Rating	HP Gain	Tube Diam	Drive System	Fuel System Upgrade	Fuel Inj. Supplied	Computer/Ignition Modifications	SC Warranty (in months)	CARB E.O.	Foot Notes
specify	1FA600-P1SC1-I	N/A	specify	3"	add'l 8 rib	not supplied	No	not supplied	12	-	J2, J7
specify	1FA600-P1SC1	N/A	specify	-	add'l 8 rib	not supplied	No	not supplied	12	-	J2, J7

FORD AUTOMOTIVE FOOTNOTES (specific to above applications):

- J1) Modified engines only
- J2) System ships in extra large box
- J3) Specify factory or aftermarket balancer
- J4) Requires 2011-14 Mustang accessories and utilizes 2011-14 Mustang intercooler and tubing
- J5) Coyote transplant kits require automotive 5.0L engine block (truck blocks are not compatible)
- J6) Requires 2015+ Mustang accessories and utilizes 2015+ Mustang intercooler and tubing
- J7) Requires Innovators West balancer (included)



2020-21 CORVETTE C8 (LT2) SYSTEMS AND KITS

Year	Part Number	Description	Boost Options	HP Gain	Intercooler	Price
2020-21	1KC332-SCI	High Output Intercooled Tuner Kit PLUS with P-1SC-1 (satin finish)	6 psi	180+ HP	A2W	\$12,899
2020-21	1KC302-SCI	High Output Intercooled Tuner Kit with P-1SC-1 (satin finish)	specify	specify	A2W	\$11,999
2020-21	1KC312-SCI	High Output Intercooled System with P-1SC-1 (satin finish)	TBD	TBD	A2W	TBD
2020-21	1KC402-SCI	Stage II Intercooled Tuner Kit (w/ port injection manifold) with P-1SC-1 (satin finish)	6-9 psi	180-225+ HP	A2W	\$12,499

Year	Part Number	Description	Boost Options	HP Gain	Intercooler	Price
C8 CORVETTE (LT2) OPTIONS	add "-B" or "-P" to part #	Black or Polished Finish for supercharger (P-series or D-series)	satin standard	-	-	+\$295
	add "-B" or "-P" to part #	Black or Polished finish for supercharger bracket (satin finish standard)	satin standard	-	-	+\$250
	add "-BI" to part #	Black Finish for Intake Manifold (raw finish standard)	unfinished std	-	-	+\$350
	add "-BC" to part #	Black Finish for Intake Manifold Cover (raw finish standard)	unfinished std	-	-	+\$50
	add "-H" to part #	Helical gearset for noise reduction (P-1SC-1, P-1X, D-1SC, D-1X)	same	same	-	+\$100
	add "-P1X" to part #	With P-1X ProCharger (replacing P-1SC-1, additional 10-15+ hp)	same	add'l 10-15+ hp	-	+\$200
	add "-D1SC" to part #	With D-1SC ProCharger (replacing P-1SC-1, Tuner Kit only)	tuner kit only	specify	-	+\$250
	add "-D1X" to part #	With D-1X ProCharger (replacing P-1SC-1, Tuner Kits only)	tuner kit only	specify	-	+\$425
	add "-CF" to part #	With carbon fiber intake manifold cover	-	-	-	call
	add "-CT" to part #	With carbon fiber trunk cover - Special Order	-	-	-	call
add "-INT/INJ" to part #	Sheet Metal Aluminum Intake Manifold w/ port injector bungs and fuel rails	HO tuner kit only	-	-	+\$500	

SPECIFICATIONS (C8 CORVETTE)

2020-21 CORVETTE C8 (LT2) SPECIFICATIONS

Year	Part Number	OEM HP Rating	HP Gain	Tube Diam	IC Mount	Drive System	Bypass System	Fuel System Upgrade	Fuel Inj. Supplied	Computer/Ignition Modifications	SC Warranty (in months)	CARB E.O.	Foot Notes
2020-21	1KC332-SCI	495	180+ HP	3.5"	A2W	stk 6 rib	Bullet	not required	no	timing control supplied	12, 36 opt. (\$99)	-	KK1, KK2, KK3, KK4, KK5, KK6, KK7, KK8
2020-21	1KC302-SCI	495	specify	3.5"	A2W	stk 6 rib	Bullet	not supplied	no	not supplied	12	-	KK1, KK2, KK3, KK4, KK5, KK6, KK7, KK8
2020-21	1KC312-SCI	495	TBD	3.5"	A2W	stk 6 rib	Bullet	TBD	TBD	TBD	TBD	-	KK1, KK2, KK3, KK4, KK5, KK6, KK7, KK8
2020-21	1KC402-SCI	495	180-225+ HP	3.5"	A2W	stk 6 rib	Bullet	not supplied	no	not supplied	12	-	KK1, KK2, KK3, KK4, KK5, KK6, KK7, KK8

CHEVROLET AUTOMOTIVE FOOTNOTES (specific to above applications):

- KK1) Does not fit convertible
- KK2) Dyno tuning is required
- KK3) Clutch upgrade may be required
- KK4) Multi-part shipment, additional shipping charges may apply
- KK5) Model year must be specified
- KK6) Carbon fiber trunk cover requires special order
- KK7) No cutting required
- KK8) Check Engine Light may be illuminated



2014-19 CORVETTE C7 STINGRAY (LT1) AND 2017-18 GRAND SPORT (LT1) SYSTEMS AND KITS

Year	Part Number	Description	Boost Options	HP Gain	Intercooler	Price
2014-19	1GU212-SCI	High Output Intercooled System with P-1SC-1 (satin finish)	7 psi	40%+	Vertical	\$6,299
2014-19	1GU202-SCI	High Output Intercooled Tuner Kit with P-1SC-1 (satin finish)	specify	specify	Vertical	\$5,999
2014-19	1GU402-F1	Competition Race Tuner Kit with F-1D, F-1 or F-1A (satin finish)	specify	specify	1250+ HP AW	\$9,999
2014-19	1GU402-F1R	Competition Race Tuner Kit with F-1A-94, F-1C or F-1R (satin finish)	specify	specify	1250+ HP AW	\$10,299
2014-19	1GU502-F1	Pro Race Tuner Kit with F-1D, F-1 or F-1A (satin finish)	specify	specify	1500+ HP AW	\$10,999
2014-19	1GU502-F1R	Pro Race Tuner Kit with F-1A-94, F-1C or F-1R (satin finish)	specify	specify	1500+ HP AW	\$11,299

2015-19 CORVETTE C7 Z06 (LT4) KITS

Year	Part Number	Description	Boost Options	HP Gain	Intercooler	Price
2015-19	1GU204-SCI	High Output Intercooled Tuner Kit with D-1SC (satin finish)	specify	specify	Vertical	\$8,499
2015-19	1GU204-SCI-F1	Intercooled Race Tuner Kit with F-1D, F-1, F-1A (satin finish)	specify	specify	Vertical	\$9,199
2015-19	1GU204-SCI-F1R	Intercooled Race Tuner Kit with F-1A-94, F-1C, or F-1R (satin finish)	specify	specify	Vertical	\$9,499
2015-19	1GU300-F1	Competition Race Tuner Kit with F-1D, F-1, F-1A (satin finish)	specify	specify	1250+ HP AW	\$10,999
2015-19	1GU300-F1R	Competition Race Tuner Kit with F-1A-94, F-1C, or F-1R (satin finish)	specify	specify	1250+ HP AW	\$11,299
2015-19	1GU500-F1	Pro Race Tuner Kit with F-1D, F-1 or F-1A (satin finish)	specify	specify	1500+ HP AW	\$11,999
2015-19	1GU500-F1R	Pro Race Tuner Kit with F-1A-94, F-1C or F-1R (satin finish)	specify	specify	1500+ HP AW	\$12,299

C7 CORVETTE (LT1 AND LT4) OPTIONS	add "-B" or "-P" to part #	Black or Polished Finish for supercharger/bracket (P-series or D-series)	satin standard	-	-	+\$545
	add "-B" or "-P" to part #	Black or Polished Finish for supercharger/bracket (F-series, 9" or 9.75" housing)	satin standard	-	-	+\$575
	add "-BI" to part #	Black Finish for Intake Manifold (unfinished standard)	unfinished std	-	-	+\$200
	add "-BC" to part #	Black Finish for Intake Manifold Cover (unfinished standard)	unfinished std	-	-	+\$30
	add "-H" to part #	Helical gearset for noise reduction (P-1SC-1, P-1X, D-1SC, D-1X)	same	same	-	+\$100
	Add "-10R" to part #	10 Rib Belt Drive Upgrade	tuner kit only	-	-	+\$325
	add "-CP" to part #	8.80" Crank Pulley Upgrade (10 rib only)	-	-	-	+\$107
C7 CORVETTE (LT1 ONLY) OPTIONS	add "-AB" to part #	Factory Air Box Inlet and Filter (Race Air Inlet and Filter standard)	7 psi max	same	-	+\$195
	add "-P1X" to part #	With P-1X ProCharger (replacing P-1SC-1, Systems and Tuner Kits)	same	add'l 10-15+ hp	-	+\$200
	add "-D1SC" to part #	With D-1SC ProCharger (replacing P-1SC-1)	tuner kit only	specify	-	+\$250
	add "-D1X" to part #	With D-1X ProCharger (replacing P-1SC-1, Tuner Kits only)	tuner kit only	specify	-	+\$425
	add "-D" or "-1" or "-A"	With F-1D, F-1, F-1A ProCharger (replacing P-1SC-1)	tuner kit only	specify	-	+\$775
	add "-94" or "-C" or "-R"	With F-1A-94, F-1C or F-1R ProCharger (replacing P-1SC-1)	tuner kit only	-	-	+\$1,100
	add "-F1X" to part #	With F-1X ProCharger (replacing P-1SC-1)	tuner kit only	-	-	+\$1,800
	add "-F1X" to part #	With F-1X ProCharger and Bellmouth (replacing F-1A-94, F-1C or F-1R)	tuner kit only	specify	-	+\$895
	add "-BV" to part #	Bullet Bypass Valve Upgrade	-	-	-	+\$105
	add "-RVR" or "-RVB"	Race Bypass Valve Upgrade (open only)	red or black	specify	-	+\$295
	add "-ATIPP" to part #	ATI Performance Products Balancer Upgrade	-	-	-	+\$475
	add "-INT" to part #	Sheet Metal Aluminum Intake Manifold and Cover (Tuner Kit Only)	unfinished std	-	-	+\$2,189
	add "-INT/INJ" to part #	Sheet Metal Aluminum Intake Manifold and Cover w/ injector bungs and fuel rails	tuner kit only	-	-	+\$2,689
C7 CORVETTE Z06 (LT4 ONLY)	add "-D1X" to part #	With D-1X ProCharger (replacing D-1SC)	tuner kit only	specify	-	+\$175
	add "-F1X" to part #	With F-1X ProCharger and Bellmouth (replacing F-1A-94, F-1C or F-1R)	specify	specify	-	+\$895
	add "-RVR" or "-RVB"	Race Bypass Valve Upgrade (open only, from Bullet)	red or black	specify	-	+\$295
	add "-INT/INJ" to part #	Sheet Metal Aluminum Intake Manifold w/ injector bungs and fuel rails (Tuner Kit Only)	unfinished std	-	-	+\$500

2014-17 CORVETTE C7 STINGRAY (LT1) i-1 PROGRAMMABLE RATIO SYSTEMS

Year	Part Number	Description	Boost Options	HP Gain	Intercooler	Price
2014-17	1GU312-SCI	High Output Intercooled Systems with i-1	7 psi	45%+	Vertical	\$8,999
i-1 OPTIONS	add "-HI"	Horizontal Intercooler Mounting Option (Vertical standard, see K8 below)	-	-	-	+\$195
	add "-T" to part #	Touchscreen (at time of system purchase)	-	-	-	+\$395
	add "-B" to part #	Black finish for supercharger and bracket	satin standard	-	-	+\$795
	add "-P" to part #	Polished finish for supercharger and bracket (satin finish standard)	satin standard	-	-	+\$595
	add "-ATIPP" to part #	ATI Performance Products Balancer Upgrade	-	-	-	+\$475

SPECIFICATIONS (C7 CORVETTE)

2014-19 CORVETTE C7 STINGRAY (LT1) AND 2017-18 GRAND SPORT (LT1) SPECIFICATIONS

Year	Part Number	OEM HP Rating	HP Gain	Tube Diam	IC Mount	Drive System	Bypass System	Fuel System Upgrade	Fuel Inj. Supplied	Computer/Ignition Modifications	SC Warranty (in months)	CARB E.O.	Foot Notes
2014-19	1GU212-SCI	455	40%+	3"	V	add'l 8 rib	ProFlow	not required	not required	programmer supplied	12, 36 opt. (\$99)	D-365-17	K1, K2, K3, K5, K6, K7, K8, K10
2014-19	1GU202-SCI	455	specify	3"	V	add'l 8 rib	ProFlow	not supplied	no	not supplied	12	-	K1, K2, K3, K5, K6, K7, K8, K9, K10, K11
2014-19	1GU402-F1	455	specify	3"	V	add'l 8 rib	Race	not supplied	no	not supplied	12	-	K1, K2, K3, K5, K6, K7, K8, K9, K10, K11
2014-19	1GU402-F1R	455	specify	3"	V	add'l 8 rib	Race	not supplied	no	not supplied	12	-	K1, K2, K3, K5, K6, K7, K8, K9, K10, K11
2014-19	1GU502-F1	455	specify	3"	V	add'l 8 rib	Race	not supplied	no	not supplied	12	-	K1, K2, K3, K5, K6, K7, K8, K9, K10, K11, K12
2014-19	1GU502-F1R	455	specify	3"	V	add'l 8 rib	Race	not supplied	no	not supplied	12	-	K1, K2, K3, K5, K6, K7, K8, K9, K10, K11, K12

2015-19 CORVETTE C7 Z06 (LT4) SPECIFICATIONS

Year	Part Number	OEM HP Rating	HP Gain	Tube Diam	IC Mount	Drive System	Bypass System	Fuel System Upgrade	Fuel Inj. Supplied	Computer/Ignition Modifications	SC Warranty (in months)	CARB E.O.	Foot Notes
2015-19	1GU204-SCI	650	specify	3"	V	add'l 8 rib	Bullet	not required	not required	not supplied	12	-	K1, K2, K5, K6, K10, K11
2015-19	1GU204-SCI-F1	650	specify	3"	V	add'l 8 rib	Race	not supplied	no	not supplied	12	-	K1, K2, K5, K6, K10, K11
2015-19	1GU204-SCI-F1R	650	specify	3"	V	add'l 8 rib	Race	not supplied	no	not supplied	12	-	K1, K2, K5, K6, K9, K10, K11
2015-19	1GU300-F1	650	specify	3"	A/W	add'l 8 rib	Race	not supplied	no	not supplied	12	-	K1, K2, K5, K6, K10, K11
2015-19	1GU300-F1R	650	specify	3"	A/W	add'l 8 rib	Race	not supplied	no	not supplied	12	-	K1, K2, K5, K6, K9, K10, K11
2015-19	1GU500-F1	650	specify	3"	A/W	add'l 8 rib	Race	not supplied	no	not supplied	12	-	K1, K2, K5, K6, K10, K11, K12
2015-19	1GU500-F1R	650	specify	3"	A/W	add'l 8 rib	Race	not supplied	no	not supplied	12	-	K1, K2, K5, K6, K9, K10, K11, K12

2014-17 CORVETTE C7 STINGRAY (LT1) i-1 SPECIFICATIONS

Year	Part Number	OEM HP Rating	HP Gain	Tube Diam	IC Mount	Drive System	Bypass System	Fuel System Upgrade	Fuel Inj. Supplied	Computer/Ignition Modifications	SC Warranty (in months)	CARB E.O.	Foot Notes
2014-17	1GU312-SCI	455	40%+	3"	V	add'l 8 rib	ProFlow	not required	not required	programmer supplied	12, 36 opt. (\$149)	-	K1, K2, K3, K4, K5, K7, K8, K10

CHEVROLET AUTOMOTIVE FOOTNOTES (specific to above applications):

- K1) Model year and manual or automatic transmission must be specified
- K2) Satin finish is now standard for Corvette systems; polished finish and black finish is optional
- K3) Specify wet or dry oil sump
- K4) Due to variability among OEM computers, and the prevalence of custom modifications, dyno tuning may be required
- K5) System ships in extra large box
- K6) Specify stock or aftermarket balancer (ATI Balancer Part Numbers: LT1 Dry #917315, LT1 Wet #917314, Z06 LT4 #917315)
- K7) Vertical intercooler recommended for drag racing use
- K8) Horizontal intercooler only available for 2014 Corvette C7's (LT1)
- K9) F-1X supercharger upgrade requires modifications
- K10) Two-part shipment, additional shipping charges may apply
- K11) Works with maximum of 10% overdrive crank pulley
- K12) Ice-tank mount welding, wiring, sway bar removal and minor vehicle trimming required



2008-13 CORVETTE C6 (LS3) SYSTEMS AND KITS

Year	Part Number	Description	Boost Options	HP Gain	Intercooler	Price
2008-13 (LS3)	1GQ212-SCI	High Output Intercooled System with P-1SC-1 (satin finish)	7 psi	45-50%+	C6 3 Core	\$6,999
2008-13 (LS3)	1GQ202-SCI	High Output Intercooled Tuner Kit with P-1SC-1 (satin finish)	specify	specify	C6 3 Core	\$6,199
2008-13 (LS3)	1GQ314-SCI	Stage II Intercooled System with P-1SC-1 (satin finish)	7 psi	45-50%+	C6 3 core	\$7,599
2008-13 (LS3)	1GQ304-SCI	Stage II Intercooled Tuner Kit with P-1SC-1 (satin finish)	specify	specify	C6 3 core	\$6,899
2008-13 (LS3)	1GQ402-SCI	Intercooled Race Kit with F-1D, F-1 or F-1A (satin finish)	specify	specify	Race	\$7,999
2008-13 (LS3)	1GQ402-F1C-SCI	Intercooled Race Kit with F-1A-94, F-1C or F-1R (satin finish)	specify	specify	Race	\$8,299

2006-13 CORVETTE C6 Z06 (LS7) SYSTEMS AND KITS

Year	Part Number	Description	Boost Options	HP Gain	Intercooler	Price
2006-13 (LS7)	1GP214-SCI	High Output Intercooled System with P-1SC-1 (satin finish)	4.5 psi	40%+	C6 3 core	\$7,099
2006-13 (LS7)	1GP204-SCI	High Output Intercooled Tuner Kit with P-1SC-1 (satin finish)	specify	specify	C6 3 core	\$6,299
2006-13 (LS7)	1GP314-SCI	Stage II Intercooled System with P-1SC-1 (satin finish)	4.5 psi	40%+	C6 3 core	\$7,799
2006-13 (LS7)	1GP304-SCI	Stage II Intercooled Tuner Kit with P-1SC-1 (satin finish)	specify	specify	C6 3 core	\$7,099
2006-13 (LS7)	1GP404-SCI	Intercooled Race Kit with F-1D, F-1 or F-1A (satin finish)	specify	specify	Race	\$8,199
2006-13 (LS7)	1GP404-F1C-SCI	Intercooled Race Kit with F-1A-94, F-1C or F-1R (satin finish)	specify	specify	Race	\$8,499

2005-07 CORVETTE C6 (LS2) SYSTEMS AND KITS

Year	Part Number	Description	Boost Options	HP Gain	Intercooler	Price
2005-07	1GP202-SCI	High Output Intercooled System with P-1SC-1 (satin finish)	6 psi	50%+	C6 3 core	\$6,999
2005-07	1GP212-SCI	High Output Intercooled Tuner Kit with P-1SC-1 (satin finish)	specify	specify	C6 3 core	\$6,199
2005-07	1GP315-SCI	Stage II Intercooled System with P-1SC-1 (satin finish)	6 psi	50%+	C6 3 core	\$7,599
2005-07	1GP305-SCI	Stage II Intercooled Tuner Kit with P-1SC-1 (satin finish)	specify	specify	C6 3 core	\$6,899
2005-07	1GP402-SCI	Intercooled Race Kit with F-1D, F-1 or F-1A (satin finish)	specify	specify	Race	\$7,999
2005-07	1GP402-F1C or -F1R-SCI	Intercooled Race Kit with F-1A-94, F-1C or F-1R (satin finish)	specify	specify	Race	\$8,299

2005-13 CORVETTE C6 (LS2, LS3, LS7) OPTIONS	add "-B" or "-P" to part #	Black or Polished Finish for supercharger and bracket (P or D-series)	satin standard	-	-	+\$545
	add "-H" to part #	Helical gearset for noise reduction (P-1SC-1, P-1X, D-1SC, D-1X)	same	same	-	+\$100
	add "-P1X" to part #	With P-1X ProCharger (replacing P-1SC-1, Systems and Tuner Kits)	same	add'l 10-15+ hp	-	+\$200
	add "-D1SC" to part #	With D-1SC ProCharger (replacing P-1SC-1)	tuner kit only	specify	-	+\$250
	add "-D1X" to part #	With D-1X ProCharger (replacing P-1SC-1, Tuner Kits only)	tuner kit only	specify	-	+\$425
	add "-D" or "-1" or "-A"	With F-1D, F-1, F-1A (replacing P-1SC-1, Stage II only, 8 rib required)	tuner kit only	specify	-	+\$775
	add "-C" or "R" to part #	With F-1C, F-1R, F1A-94 (replacing P-1SC-1, Stage II only, 8 rib required)	tuner kit only	specify	-	+\$1,100
	add "-F1X" to part #	With F-1X ProCharger (replacing F-1C/F-1R, Race kit only)	tuner kit only	specify	-	+\$876
	add "-8R" to part #	8 rib dedicated drive upgrade (Stage II, time of purchase, see footnotes)	from 6 rib	specify	-	+\$325
	add "-WP" to part #	With Modified Water Pump for LS3/LS7	from 3 core	1300 hp max	-	+\$149
add "-Race" to part #	Air-to-Air Race Intercooler Upgrade (HO, Stage II only)	tuner kit only	specify	-	+\$345	
add "-RVR" or "RVB"	Race Bypass Valve Upgrade (HO, Stage II only, included in Race Kits)	red or black	specify	-	+\$295	

2008-13 CORVETTE C6 (LS3) i-1 PROGRAMMABLE RATIO SYSTEMS

Year	Part Number	Description	Boost Options	HP Gain	Std Intercooler	Price
2008-13 (LS3)	1GQ312-SCI	High Output Intercooled System with i-1 (satin finish)	7 psi	50%+	C6 3 core	\$8,999

i-1 OPTIONS	add "-T" to part #	Touchscreen (at time of system purchase)	-	-	-	+\$395
	add "-B" to part #	Black finish for supercharger and bracket	satin standard	-	-	+\$795
	add "-P" to part #	Polished finish for supercharger and bracket (satin finish standard)	satin standard	-	-	+\$595
	add "-R" to part #	Air-to-Air Race Intercooler Upgrade	from C6 3 core	-	-	+\$345

SPECIFICATIONS (C6 CORVETTE)

2008-13 CORVETTE C6 (LS3) SPECIFICATIONS

Year	Part Number	OEM HP Rating	HP Gain	Tube Diam	IC Mount	Drive System	Bypass System	Fuel System Upgrade	Fuel Inj. Supplied	Computer/Ignition Modifications	SC Warranty (in months)	CARB E.O.	Foot Notes
2008-13	1GQ212-SCI	430	45-50%+	3"	V	stk 6 rib	ProFlow	not required	50 lb/hr	programmer sup.	12, 36 opt. (\$99)	-	L1, L2, L3, L4, L6, L8, L9, L10, L11, L12
2008-13	1GQ202-SCI	430	specify	3"	V	stk 6 rib	ProFlow	not supplied	no	not supplied	12	-	L1, L2, L3, L6, L8, L9, L10, L11, L12
2008-13	1GQ314-SCI	430	45-50%+	3"	V	add'l 6 rib	ProFlow	not required	50 lb/hr	programmer sup.	12, 36 opt. (\$99)	-	L1, L2, L3, L4, L5, L6, L8, L9, L10, L11, L12
2008-13	1GQ304-SCI	430	specify	3"	V	add'l 6 rib	ProFlow	not supplied	no	not supplied	12	-	L1, L2, L3, L5, L6, L8, L9, L10, L11, L12
2008-13	1GQ402-SCI	430	specify	4"	V	add'l 10 rib	Race	not supplied	no	not supplied	-	-	L1, L2, L3, L7, L8, L9, L10, L11, L12
2008-13	1GQ402-F1C-SCI	430	specify	4"	V	add'l 10 rib	Race	not supplied	no	not supplied	-	-	L1, L2, L3, L6, L7, L8, L9, L10, L11, L12

2006-13 CORVETTE Z06 (LS7) SPECIFICATIONS

Year	Part Number	OEM HP Rating	HP Gain	Tube Diam	IC Mount	Drive System	Bypass System	Fuel System Upgrade	Fuel Inj. Supplied	Computer/Ignition Modifications	SC Warranty (in months)	CARB E.O.	Foot Notes
2006-13	1GP214-SCI	505	40%+	3"3.5"	V	stk 6 rib	ProFlow	not required	65 lb/hr	programmer sup.	12, 36 opt. (\$99)	-	L1, L2, L4, L6, L8, L10, L11, L12
2006-13	1GP204-SCI	505	specify	3"3.5"	V	stk 6 rib	ProFlow	not supplied	No	not supplied	12	-	L1, L2, L6, L8, L10, L11, L12
2006-13	1GP314-SCI	505	40%+	3"3.5"	V	add'l 6 rib	ProFlow	not required	65 lb/hr	programmer sup.	12, 36 opt. (\$99)	-	L1, L2, L4, L5, L6, L8, L10, L11, L12
2006-13	1GP304-SCI	505	specify	3"3.5"	V	add'l 6 rib	ProFlow	not supplied	No	not supplied	12	-	L1, L2, L5, L6, L8, L10, L11, L12
2006-13	1GP404-SCI	505	specify	4"	V	add'l 10 rib	Race	not supplied	No	not supplied	-	-	L1, L2, L6, L7, L8, L10, L11, L12
2006-13	1GP404-F1C-SCI	505	specify	4"	V	add'l 10 rib	Race	not supplied	No	not supplied	-	-	L1, L2, L6, L7, L8, L10, L11, L12

2005-07 CORVETTE C6 (LS2) SPECIFICATIONS

Year	Part Number	OEM HP Rating	HP Gain	Tube Diam	IC Mount	Drive System	Bypass System	Fuel System Upgrade	Fuel Inj. Supplied	Computer/Ignition Modifications	SC Warranty (in months)	CARB E.O.	Foot Notes
2005-07	1GP202-SCI	400	50%+	3"3.5"	V	stk 6 rib	ProFlow	not required	57 lb/hr	programmer sup.	12, 36 opt. (\$99)	D-365-6 (05)	L1, L2, L3, L8, L10, L11, L12
2005-07	1GP212-SCI	400	specify	3"3.5"	V	stk 6 rib	ProFlow	not supplied	No	not supplied	12	-	L1, L2, L3, L8, L10, L11, L12
2005-07	1GP315-SCI	400	50%+	3"3.5"	V	add'l 6 rib	ProFlow	not required	57 lb/hr	programmer sup.	12, 36 opt. (\$99)	-	L1, L2, L3, L4, L5, L8, L10, L11, L12
2005-07	1GP305-SCI	400	specify	3"3.5"	V	add'l 6 rib	ProFlow	not supplied	No	not supplied	12	-	L1, L2, L3, L5, L8, L10, L11, L12
2005-07	1GP402-SCI	400	specify	4"	V	add'l 10 rib	Race	not supplied	No	not supplied	-	-	L1, L2, L3, L7, L8, L10, L11, L12
2005-07	1GP402-F1C-SCI	400	specify	4"	V	add'l 10 rib	Race	not supplied	No	not supplied	-	-	L1, L2, L3, L7, L8, L10, L11, L12

2008-13 CORVETTE C6 (LS3) i-1 SPECIFICATIONS

Year	Part Number	OEM HP Rating	HP Gain	Tube Diam	IC Mount	Drive System	Bypass System	Fuel System Upgrade	Fuel Inj. Supplied	Computer/Ignition Modifications	SC Warranty (in months)	CARB E.O.	Foot Notes
2008-13	1GQ312-SCI	430	50%+	3"	V	stk 6 rib	ProFlow	pump voltage booster	50 lb/hr	programmer sup.	12, 36 opt. (\$149)	-	L1, L2, L3, L4, L8, L9, L11, L12

CHEVROLET AUTOMOTIVE FOOTNOTES (specific to above applications):

- L1) Model year and manual or automatic transmission must be specified
- L2) Satin finish is now standard for Corvette systems; polished finish and black finish is optional
- L3) Specify wet or dry oil sump
- L4) Due to variability among OEM computers and prevalence of custom mods, dyno tuning may be required
- L5) 8-rib drive system upgrade is available for 2005-13 C6 and Grand Sport Stage II Systems/Tuner Kits and requires ATI PP balancer #917345 (LS3/LS2, wet sump) or #918620 (LS7/GS, dry sump) (not supplied), or Innovator's West balancer #843 (LS3/LS2, wet sump) or #853 (LS7/GS, dry sump) (not included - specify hardened hub)

- L6) 2009-13 models require water pump modification (water pump available from ProCharger)
- L7) Requires 10-rib ATI PP balancer #917347X (LS3/LS2, wet sump) (not supplied), or Innovator's West balancer #844 (LS3/LS2, wet sump) or #854 (LS7/GS, dry sump) (not included - specify hardened hub)
- L8) System ships in extra large box
- L9) Grand Sport Corvette applications must be noted at time of order, including body style
- L10) Race intercooler option requires oil cooler relocation (not supplied)
- L11) Specify stock or aftermarket balancer
- L12) Two-part shipment, additional shipping charges may apply



1997-04 CORVETTE C5, Z06 (LS1, LS6) SYSTEMS AND KITS

Year	Part Number	Description	Boost Options	HP Gain	Intercooler	Price
1999-04 (LS1)	1GK213-SCI	Stage II Intercooled System with P-1SC-1 (satin finish)	7 psi	55%+	4.5" twin highflow	\$6,999
1997-04 (LS1)	1GK203-SCI	Stage II Intercooled Tuner Kit with P-1SC-1 (satin finish)	specify	specify	4.5" twin highflow	\$6,249
1997-04 (LS1)	1GK205-SCI-R	Intercooled Serp (8 rib) Race Kit with F-1A (satin finish)	specify	specify	4.5" twin highflow	\$7,599
2001-04 (LS6)	1GK216-SCI	Stage II Intercooled System with P-1SC-1 (satin finish)	6 psi	50%+	4.5" twin highflow	\$6,999
2001-04 (LS6)	1GK206-SCI	Stage II Intercooled Tuner Kit with P-1SC-1 (satin finish)	specify	specify	4.5" twin highflow	\$6,249
2001-04 (LS6)	1GK205-SCI-R	Intercooled Serp (8 rib) Race Kit with F-1A (satin finish)	specify	specify	4.5" twin highflow	\$7,599

1997-04 C5 & Z06 (LS1, LS6)	add "-P" to part #	Polished Finish for supercharger and bracket (satin standard)	satin standard	-	-	+\$545
	add "-H" to part #	Helical gerset for noise reduction (P-1SC-1, D-1SC)	same	same	-	+\$100
	add "-D1SC" to part #	With D-1SC ProCharger (replacing P-1SC-1)	tuner kit only	specify	-	+\$250
	add "-8R" to part #	8 rib drive system upgrade (time of purchase only)	from 6 rib	specify	-	+\$325

1992-96 CORVETTE C4 (LT1, LT4) SYSTEMS AND KITS

Year	Part Number	Description	Boost Options	HP Gain	Intercooler	Price
1992-95 (LT1)	1GF211-SCI	High Output Intercooled System with P-1SC (satin finish)	8 psi	55-60%	LT1 Vette 2 core	\$6,249
1992-95 (LT1)	1GF201-SCI	High Output Intercooled Tuner Kit with P-1SC (satin finish)	specify	specify	LT1 Vette 2 core	\$5,999
1996 (LT4)	1GF212-SCI	High Output Intercooled System with P-1SC (satin finish)	6 psi	45-50%	LT1 Vette 2 core	\$6,249
1996 (LT4)	1GF202-SCI	High Output Intercooled Tuner Kit with P-1SC (satin finish)	specify	specify	LT1 Vette 2 core	\$5,999

1992-96 C4 (LT1, LT4) OPTIONS	add "-P" to part #	Polished Finish for supercharger and bracket (satin standard)	satin standard	-	-	+\$545
	add "-H" to part #	Helical gerset for noise reduction (P-1SC, D-1SC)	same	same	-	+\$100
	add "-D1SC" to part #	With D-1SC ProCharger (replacing P-1SC)	tuner kit only	specify	-	+\$450
	MA0011-001	Mass Airflow Massager (required for 1996 only)	1996 only	-	-	+\$199

1985-91 CORVETTE C4 TPI (L98) SYSTEMS AND KITS

Year	Part Number	Description	Boost Options	HP Gain	Intercooler	Price
1985-91 (L98)	1GB212-08I	High Output Intercooled System with P600B (satin finish)	8 psi	55-75%	2 core (85-89) Twin (90-91)	\$5,699
1985-91 (L98)	1GB211-06S	High Output Kit with P600B (satin finish)	specify	specify	-	\$4,649
1985-91 (L98)	1GB212-D1	High Output Intercooled System with D-1 (satin finish)	10+ psi	75%+	2 core (85-89) Twin (90-91)	\$6,149
1985-91 (L98)	1GB211-D1	High Output Tuner Kit with D-1 (satin finish)	specify	specify	-	\$5,099

1987-92 TPI (L98) OPTIONS	add "-P" to part #	Polished Finish for supercharger and bracket (satin standard)	satin standard	-	-	+\$545
	add "-OF" to part #	Omit FMU (D-1 system only)	-	-	-	-\$88
	add "-OP" to part #	Omit in-line fuel pump (D-1 system only)	-	-	-	-\$98

SPECIFICATIONS (C5/C4 CORVETTE)

1997-04 CORVETTE C5, Z06 (LS1, LS6) SPECIFICATIONS

Year	Part Number	OEM HP Rating	HP Gain	Tube Diam	IC Mount	Drive System	Bypass System	Fuel System Upgrade	Fuel Inj. Supplied	Computer/Ignition Modifications	Supercharger Warranty (in months)	CARB E.O.	Foot Notes
1999-04	1GK213-SCI	345	55%+	3" ea	V	stk 6 rib	ProFlow	not required	38 lb/hr	programmer sup.	12, 36 opt. (\$99)	D-365-6	M1, M2, M4, M5
1997-04	1GK203-SCI	345	specify	3" ea	V	stk 6 rib	ProFlow	not supplied	No	not supplied	12	-	M1, M2, M4, M5
1997-04	1GK205-SCI-R	-	specify	3" ea	V	8 rib	Race	not supplied	No	not supplied	12	-	M1, M2, M5, M4, M5, M6
2001-04	1GK216-SCI	405	50%+	3" ea	V	stk 6 rib	ProFlow	not required	38 lb/hr	programmer sup.	12, 36 opt. (\$99)	D-365-6	M1, M2, M4, M5
2001-04	1GK206-SCI	405	specify	3" ea	V	stk 6 rib	ProFlow	not supplied	No	not supplied	12	-	M1, M2, M4, M5
2001-04	1GK205-SCI-R	-	specify	3" ea	V	8 rib	Race	not supplied	No	not supplied	12	-	M1, M2, M5, M4, M5, M6

1992-96 CORVETTE C4 (LT1, LT4) SPECIFICATIONS

Year	Part Number	OEM HP Rating	HP Gain	Tube Diam	IC Mount	Drive System	Bypass System	Fuel System Upgrade	Fuel Inj. Supplied	Computer/Ignition Modifications	Supercharger Warranty (in months)	CARB E.O.	Foot Notes
1992-95	1GF211-071 / 091	300	55-60%	3"	V	stk 6 rib	Bosch	ProPump, FMU	not req.	not required	12, 36 opt. (\$99)	D-365-3	M1, M2, M7, M11, M12
1992-95	1GF201-SCI	300	specify	3"	V	stk 6 rib	Bosch	not supplied	No	not supplied	12	-	M1, M2, M7, M11, M12
1996	1GF212-SCI	330	45-50%	3"	V	stk 6 rib	Bosch	ProPump, FMU	not req.	not required	12, 36 opt. (\$99)	-	M1, M2, M7, M11, M12
1996	1GF202-SCI	330	specify	3"	V	stk 6 rib	Bosch	not supplied	No	not supplied	12	-	M1, M2, M8, M11, M12

1985-91 CORVETTE C4 TPI (L98) SPECIFICATIONS

Year	Part Number	OEM HP Rating	HP Gain	Tube Diam	IC Mount	Drive System	Bypass System	Fuel System Upgrade	Fuel Inj. Supplied	Computer/Ignition Modifications	Supercharger Warranty (in months)	CARB E.O.	Foot Notes
1985-91	1GB212-081	230-250	55-75%	2.5"	V or Twin	stk 6 rib	Bosch	ProPump, FMU	not req.	not required	36	D-365-3	M1, M2, M5, M9 (12 psi), M10, M11
1985-91	1GB211-06S	230-250	specify	3"	-	stk 6 rib	not required	ProPump, FMU	No	not required	36	-	M1, M2, M10, M11
1985-91	1GB212-D1	230-250	75%+	2.5"	V or Twin	stk 6 rib	Bosch	ProPump, FMU	No	not required	12	-	M1, M2, M5, M9 (12 psi), M10, M11
1985-91	1GB211-D1	230-250	specify	3"	-	stk 6 rib	not supplied	-	No	not required	12	-	M1, M2, M5, M8, M10, M11

CHEVROLET AUTOMOTIVE FOOTNOTES (specific to above applications):

- M1) Model year and manual or automatic transmission must be specified
- M2) Satin finish is now standard for Corvette systems; polished finish is optional
- M3) Due to variability among OEM computers, and the prevalence of custom modifications, dyno tuning may be required
- M4) 8-rib drive systems require use of ATI Performance Products aftermarket balancer (LS1, LS6 part #917345) (not included - specify hardened hub)
- M5) System ships in extra large box
- M6) Utilizes 8 rib accessory drive system which replaces the factory 6 rib serpentine pulleys and belt
- M7) Mass airflow massager required for 1996 LT1's (sold separately by ProCharger)
- M8) Modified engines only
- M9) Larger fuel injectors may be required (sold separately by others)
- M10) Some GM suspension options may require slight modification to hood reinforcement or supercharger bracket
- M11) Special order kit: order form and non-refundable deposit required at time of order—may require additional lead time for processing
- M12) A/C line may need to be modified or removed



2016-21 CAMARO SS (LT1) SYSTEMS AND KITS

Year	Part Number	Description	Boost Options	HP Gain	Intercooler	Price
2016-21	1GY211-SCI	Intercooled System with Factory Airbox and P-1SC-1 only	7 psi	150+ HP	3 core	\$6,549
2016-21	"add SII"	Stage II Intercooler Option for Factory Airbox System P-1SC-1 only	7 psi	Add'l 20+ HP	From 3 core	+\$345
2016-21	1GY212-SCI	High Output Intercooled System with P-1SC-1	7 psi	150+ HP	3 core	\$6,649
2016-21	1GY202-SCI	High Output Intercooled Tuner Kit with P-1SC-1	specify	specify	3 core	\$6,349
2016-21	1GY312-SCI	Stage II Intercooled System with P-1SC-1	7 psi	170+ HP	Stage II	\$6,999
2016-21	1GY302-SCI	Stage II Intercooled Tuner Kit with P-1SC-1	specify	specify	Stage II	\$6,699
2016-21	1GY402-F1	Competition Race Tuner Kit with F-1D, F-1 or F-1A	specify	specify	1250+ HP AW	\$9,949
2016-21	1GY402-F1R	Competition Race Tuner Kit with F-1A-94, F-1C or F-1R	specify	specify	1250+ HP AW	\$10,279

2017-21 CAMARO ZL1 (LT4) KITS

Year	Part Number	Description	Boost Options	HP Gain	Intercooler	Price
2017-21	1GY204-SCI	Stage II Intercooled Tuner Kit with D-1SC	specify	specify	Stage II	\$8,499
2017-21	1GY404-F1	Intercooled Race Tuner Kit with F-1D, F-1 or F-1A	specify	specify	Race	\$9,299
2017-21	1GY404-F1R	Intercooled Race Tuner Kit with F-1A-94, F-1C or F-1R	specify	specify	Race	\$9,599
2017-21	1GY300-F1	Competition Race Tuner Kit with F-1D, F-1 or F-1A	specify	specify	1250+ HP AW	\$11,199
2017-21	1GY300-F1R	Competition Race Tuner Kit with F-1A-94, F-1C or F-1R	specify	specify	1250+ HP AW	\$11,519

2016-20 CAMARO V6 (3.6) SYSTEM AND KIT

Year	Part Number	Description	Boost Options	HP Gain	Intercooler	Price
2016-20	1GZ212-SCI	High Output Intercooled System with P-1SC-1	7 psi	Call	750+ HP	\$5,799
2016-20	1GZ202-SCI	High Output Intercooled Tuner Kit with P-1SC-1	specify	specify	750+ HP	\$5,499

2016-19 CADILLAC CTS-V (LT4)

Year	Part Number	Description	Boost Options	HP Gain	Intercooler	Price
2016-19	1GY704-SCI	Stage II Intercooled Tuner Kit with D-1SC	specify	specify	Stage II	\$8,499

CTS-V, SS, ZL1, V6 OPTIONS	add "-B" or "-P" to part #	Black or Polished finish for ProCharger (P-series or D-series)	satin standard	-	-	+\$295
	add "-B" or "-P" to part #	Black or Polished finish for ProCharger (F-series, 9" or 9.75" housing)	satin standard	-	-	+\$325
	add "-BB" or "-PB" to part #	Black or Polished finish for supercharger bracket	satin standard	-	-	+\$250
	add "-H" to part #	Helical gears for noise reduction (P-1SC-1, P-1X, D-1SC, D-1X)	same	same	-	+\$100
CAMARO SS OPTIONS ONLY	add "-RVR" or "RVB"	Race Bypass Valve (open only, already included in Race kits)	red or black	specify	-	+\$295
	add "-P1X" to part #	With P-1X ProCharger (replacing P-1SC-1, not available for SS factory airbox system)	same	add'l 10-15+ hp	-	+\$200
	add "-D1SC" to part #	With D-1SC ProCharger (replacing P-1SC-1 - Stage II only)	tuner kit only	specify	-	+\$250
	add "-D1X" to part #	With D-1X ProCharger (replacing P-1SC-1 - Stage II only)	tuner kit only	specify	-	+\$425
	add "-D" or "-1" or "-A"	With F-1D, F-1 or F-1A ProCharger (replacing P-1SC-1)	tuner kit only	specify	-	+\$775
	add "-94"	With F-1A-94 (replacing P-1SC-1, Stage II Tuner kits only)	tuner kit only	-	-	+\$1,100
	add "-INT" to part #	Sheet Metal Aluminum Intake Manifold/Cover (Stage II Tuner Kit Only)	unfinished std	-	-	+\$2,189
add "-INT/INJ" to part #	Sheet Metal Aluminum Intake Manifold w/ injector bungs and fuel rails (Stage II only)	tuner kit only	-	-	+\$2,689	
CTS-V AND ZL1 OPTIONS ONLY	add "-D1X" to part #	With D-1X ProCharger (replacing D-1SC)	tuner kit only	specify	-	+\$175
	add "-D" or "-1" or "-A"	With F-1D, F-1 or F-1A ProCharger (replacing D-1SC)	tuner kit only	specify	-	+\$525
	add "-94"	With F-1A-94 (replacing D-1SC, Stage II Tuner kits only)	tuner kit only	-	-	+\$850
	add "-INT/INJ" to part #	Sheet Metal Aluminum Intake Manifold w/ injector bungs and fuel rails	unfinished std	-	-	+\$500
CTS-V, CAMARO SS, ZL1 ONLY	add "-BI" to part #	Black Finish for Intake Manifold (unfinished standard)	unfinished std	-	-	+\$200
	add "-BC" to part #	Black Finish for Intake Manifold Cover (unfinished standard)	unfinished std	-	-	+\$30
	add "-10R" to part #	10 Rib Belt Drive Upgrade	tuner kit only	-	-	+\$325
	add "-ATIPP" to part #	ATI Performance Products Balancer Upgrade (# 918856)	-	-	-	+\$475
	add "-CP" to part #	8.25" Crank Pulley Upgrade	7.65" standard	-	-	+\$107
	add "-Race" to part #	Air-to-Air Race Intercooler (Stage II Systems and kits only)	from Stage II	specify	-	+\$345
ZL1 ONLY	add "-AWR" to part #	Air-to-Water Race Intercooler (Camaro Stage II Tuner kits only)	from Stage II	specify	-	+\$2,499
V6 ONLY	add "-AIR" to part #	Stage II Air Inlet Upgrade Package (Replacing Factory Airbox)	same	specify	-	+\$39

2016-19 CADILLAC CTS V6 (3.6) - COMING SOON

SPECIFICATIONS (2016-21 CAMARO AND CTS-V)

2016-21 CAMARO SS (LT1) SPECIFICATIONS

Year	Part Number	OEM HP Rating	HP Gain	Tube Diam	Intercooler Mount	Drive System	Bypass System	Fuel System Upgrade	Fuel Inj. Supplied	Computer/Ignition Modifications	Supercharger Warranty (in months)	CARB E.O.	Foot Notes
2016-21	1GY211-SCI	455	150+ HP	3"	V	stk 6 rib	Bullet	not required	not required	programmer supplied	12, 36 opt. (\$99)	D-365-25 (16-20)	N1, N3
2016-21	"add -SII"	455	Add'l 20+ HP	3"	V	stk 6 rib	Bullet	not required	not required	programmer supplied	12, 36 opt. (\$99)	D-365-25 (16-20)	
2016-21	1GY212-SCI	455	150+ HP	3"	V	add'l 8 rib	ProFlow	not required	not required	programmer supplied	12, 36 opt. (\$99)	-	N1, N2, N3, N4, N5, N9
2016-21	1GY202-SCI	455	specify	3"	V	add'l 8 rib	ProFlow	not supplied	no	not supplied	12	-	N1, N3, N4, N5, N9
2016-21	1GY312-SCI	455	170+ HP	3"	V	add'l 8 rib	ProFlow	not required	not required	programmer supplied	12, 36 opt. (\$99)	-	N1, N2, N3, N4, N5, N6, N9
2016-21	1GY302-SCI	455	specify	3"	V	add'l 8 rib	ProFlow	not supplied	no	not supplied	12	-	N1, N3, N4, N5, N6, N9
2016-21	1GY402-F1	455	specify	3"	V	add'l 8 rib	Race	not supplied	no	not supplied	12	-	N1, N3, N4, N5, N6, N9
2016-21	1GY402-F1R	455	specify	3"	V	add'l 8 rib	Race	not supplied	no	not supplied	12	-	N1, N3, N4, N5, N6, N9

2017-21 CAMARO ZL1 (LT4) SPECIFICATIONS

Year	Part Number	OEM HP Rating	HP Gain	Tube Diam	Intercooler Mount	Drive System	Bypass System	Fuel System Upgrade	Fuel Inj. Supplied	Computer/Ignition Modifications	Supercharger Warranty (in months)	CARB E.O.	Foot Notes
2017-21	1GY204-SCI	650	specify	3"	V	add'l 8 rib	Bullet	not supplied	no	not supplied	12	-	N1, N3, N7, N8, N9
2017-21	1GY404-F1	650	specify	3"	V	add'l 8 rib	Race	not required	no	not supplied	12	-	N1, N3, N7, N8, N9
2017-21	1GY404-F1R	650	specify	3"	V	add'l 8 rib	Race	not supplied	no	not supplied	12	-	N1, N3, N6, N7, N8, N9
2017-21	1GY300-F1	650	specify	3"	A/W	add'l 8 rib	Race	not supplied	no	not supplied	12	-	N1, N3, N7, N8, N9
2017-21	1GY300-F1R	650	specify	3"	A/W	add'l 8 rib	Race	not supplied	no	not supplied	12	-	N1, N3, N6, N7, N8, N9

2016-20 CAMARO V6 (3.6) SPECIFICATIONS

Year	Part Number	OEM HP Rating	HP Gain	Tube Diam	Intercooler Mount	Drive System	Bypass System	Fuel System Upgrade	Fuel Inj. Supplied	Computer/Ignition Modifications	Supercharger Warranty (in months)	CARB E.O.	Foot Notes
2016-20	1GZ212-SCI	335	call	3"	V	stk 6 rib	ProFlow	not required	not required	programmer supplied	12, 36 opt. (\$99)	D-365-27	N1, N2, N3, N10
2016-20	1GZ202-SCI	335	specify	3"	V	stk 6 rib	ProFlow	not supplied	no	not supplied	12	-	N1, N3, N10

2016-19 CADILLAC CTS-V (LT4) SPECIFICATIONS

Year	Part Number	OEM HP Rating	HP Gain	Tube Diam	Intercooler Mount	Drive System	Bypass System	Fuel System Upgrade	Fuel Inj. Supplied	Computer/Ignition Modifications	Supercharger Warranty (in months)	CARB E.O.	Foot Notes
2016-19	1GY704-SCI	650	specify	3"	V	add'l 8 rib	Bullet	not supplied	no	not supplied	12	-	N1, N3, N8, N9

CHEVROLET AUTOMOTIVE FOOTNOTES (specific to above applications):

- N1) Model year must be specified
- N2) Due to variability among OEM computers, and the prevalence of custom modifications, dyno tuning may be required
- N3) System ships in extra large box
- N4) Race intercooler upgrades requires trimming and removal of driver-side radiator
- N5) Specify stock or aftermarket balancer
- N6) Inner fender modifications required for F-1C and F-1R head units
- N7) Inner bumper support modification or removal required for Race and Air-to-Water intercoolers
- N8) Requires ATI PP balancer #918856 (not included - specify hardened hub)
- N9) Works with maximum of 10% overdrive crank pulley
- N10) Factory balancer only



2010-15 CAMARO SS (LS3, L99) SYSTEMS AND KITS

Year	Part Number	Description	Boost Options	HP Gain	Intercooler	Price
2010-15	1GT214-SCI	High Output Intercooled System with supplied airbox and P-1SC-1	7 psi	50%+	3 core	\$7,549
2010-15	1GT212-SCI	High Output Intercooled System with P-1SC-1	7 psi	50%+	3 core	\$7,399
2010-15	1GT202-SCI	High Output Intercooled Tuner Kit with P-1SC-1	specify	specify	3 core	\$6,699
2010-15	1GT314-SCI	Stage II Intercooled System with supplied airbox and P-1SC-1	7.5 psi	55%+	Race	\$8,149
2010-15	1GT312-SCI	Stage II Intercooled System with P-1SC-1	7.5 psi	55%+	Race	\$7,999
2010-15	1GT302-SCI	Stage II Intercooled Tuner Kit with P-1SC-1	specify	specify	Race	\$7,299

2014-15 CAMARO Z/28 (LS7) SYSTEMS AND KITS

Year	Part Number	Description	Boost Options	HP Gain	Intercooler	Price
2014-15	1GT414-SCI	Stage II Intercooled System with P-1SC-1	6.5 psi	120+ HP	750+ HP	\$7,999
2014-15	1GT404-SCI	Stage II Intercooled Tuner Kit with P-1SC-1	specify	specify	750+ HP	\$7,299

2014-15 CAMARO Z/28 (LS7) AND 2010-15 CAMARO SS (LS3, L99) OPTIONS	add "-B" or "-P" to part #	Black or Polished finish for ProCharger (P-series or D-series)	satin standard	-	-	+\$295
	add "-B" or "-P" to part #	Black or Polished finish for ProCharger (F-series, 9" or 9.75" housing)	satin standard	-	-	+\$325
	add "-BB" or "-PB" to part #	Black or Polished finish for supercharger bracket	satin standard	-	-	+\$250
	add "-H" to part #	Helical gerset for noise reduction (P-1SC-1, P-1X, D-1SC, D-1X)	same	same	-	+\$100
	add "-P1X" to part #	With P-1X ProCharger (replacing P-1SC-1, Systems and Tuner Kits)	same	add'l 10-15+ hp	-	+\$200
	add "-D1SC" to part #	With D-1SC ProCharger (replacing P-1SC-1)	tuner kit only	specify	-	+\$250
	add "-D1X" to part #	With D-1X ProCharger (replacing P-1SC-1, Tuner Kits only)	tuner kit only	specify	-	+\$425
	add "-D" or "-1" or "-A"	With F-1D, F-1, F-1A ProCharger (replacing P-1SC-1)	tuner kit only	specify	-	+\$775
CAMARO SS (LS3, L99) ONLY	add "-94" or "-C" or "-R"	With F-1A-94, F-1C or F-1R ProCharger (replacing P-1SC-1)	tuner kit only	-	-	+\$1,100
	add "-RV" to part #	Race Bypass Valve Upgrade (specify open or closed valve)	red or black	specify	-	+\$295
	add "-F1X" to part #	With F-1X ProCharger (replacing P-1SC-1)	tuner kit only	-	-	+\$1,800
	add "-AIR" to part #	With Stage II air inlet upgrade package (replacing std inlet)	same	specify	-	+\$39
	add "-10R" to part #	10 rib drive system upgrade (Stage II only)	from 8 rib	specify	-	+\$325
	add "-3R" to part #	With Sheet Metal 3 Core Race Intercooler (1300 hp)	from Race	-	-	+\$345
	add "-ATIPP" to part #	ATI Performance Products Balancer Upgrade	-	-	-	+\$475
	Z/28 ONLY	add "-Race" to part #	1200+ HP Intercooler Upgrade (replacing 750+ HP intercooler)	from 750+ hp	1200+ hp	-

2010-15 CAMARO SS (LS3, L99) i-1 PROGRAMMABLE RATIO SYSTEMS

Year	Part Number	Description	Boost Options	HP Gain	Intercooler	Price
EBIRD TPI (L99)	1GT313-SCI	Stage II Intercooled System with i-1	7.5 psi	55%+	Race	\$8,899

i-1 OPTIONS	add "-T" to part #	Touchscreen (at time of system purchase)	-	-	-	+\$395
	add "-B" to part #	Black finish (supercharger and bracket)	satin standard	-	-	+\$795
	add "-P" to part #	Polished finish (supercharger and bracket)	satin standard	-	-	+\$595
	add "-ATIPP" to part #	ATI Performance Products Balancer Upgrade	-	-	-	+\$475

2010-15 CAMARO SS COG RACE KITS

Year	Part Number	Description	Boost Options	HP Gain	Intercooler	Price
2010-15	1GT200-F1-I	Intercooled Cog Race Kit with F-1D, F-1, or F-1A	specify	specify	Race	\$8,899
2010-15	1GT200-F1	Cog Race Kit with F-1D, F-1, or F-1A	specify	specify	-	\$7,399

2010-15 CAMARO SS COG RACE OPTIONS	add "-94" or "-C" or "-R"	With F-1A-94, F-1C or F-1R ProCharger (replacing F-1D, F-1 or F-1A)	from F-1/D/A	specify	-	+\$330
	add "-F1X" to part #	With F-1X ProCharger (replacing F-1D, F-1, or F-1A)	from F-1/D/A	specify	-	+\$1,240
	add "-3R" to part #	With sheet metal 3 core race intercooler (1300 hp)	from Race	3.5" in/outlet	-	+\$345
	W11005A-001	With Air-to-Water race intercooler (race use only)	from non-ic kit	1,800 hp max	-	+\$2,199
	W11005A-002	With Air-to-Water race intercooler (race use only)	from non-ic kit	2,500+ hp max	-	+\$2,699

SPECIFICATIONS (2010-15 CAMARO)

2010-15 CAMARO SS (LS3, L99) SPECIFICATIONS

Year	Part Number	OEM HP Rating	HP Gain	Tube Diam	Intercooler Mount	Drive System	Bypass System	Fuel System Upgrade	Fuel Inj. Supplied	Computer/Ignition Modifications	Supercharger Warranty (in months)	CARB E.O.	Foot Notes
2010-15	1GT214-SCI	426/400	50%+	3"	V	add'l 8 rib	ProFlow	not required	50 lb/hr	programmer supplied	12, 36 opt. (\$99)	D-365-13	O1, O4, O6
2010-15	1GT212-SCI	426/400	50%+	3"	V	add'l 8 rib	ProFlow	not required	50 lb/hr	programmer supplied	12, 36 opt. (\$99)	-	O1, O2, O4, O6
2010-15	1GT202-SCI	426/400	specify	3"	V	add'l 8 rib	ProFlow	not supplied	no	not supplied	12	-	O1, O4, O6, O10
2010-15	1GT314-SCI	426/400	50%+	3"	V	add'l 8 rib	ProFlow	pump voltage booster	50 lb/hr	programmer supplied	12, 36 opt. (\$99)	D-365-13	O1, O3, O4, O6
2010-15	1GT312-SCI	426/400	50%+	3"	V	add'l 8 rib	ProFlow	pump voltage booster	50 lb/hr	programmer supplied	12, 36 opt. (\$99)	-	O1, O2, O3, O4, O6
2010-15	1GT302-SCI	426/400	specify	3"	V	add'l 8 rib	ProFlow	not supplied	no	not supplied	12	-	O1, O3, O5, O4, O6, O10

2014-15 CAMARO Z/28 (LS7) SPECIFICATIONS

Year	Part Number	OEM HP Rating	HP Gain	Tube Diam	Intercooler Mount	Drive System	Bypass System	Fuel System Upgrade	Fuel Inj. Supplied	Computer/Ignition Modifications	Supercharger Warranty (in months)	CARB E.O.	Foot Notes
2014-15	1GT414-SCI	505	120+ HP	3"	V	add'l 8 rib	ProFlow	pump voltage booster	65 lb/hr	programmer supplied	12, 36 opt. (\$99)	-	O1, O2, O4, O5, O6
2014-15	1GT404-SCI	505	specify	3"	V	add'l 8 rib	ProFlow	not supplied	no	not supplied	12	-	O1, O2, O4, O5, O6, O10

2010-15 CAMARO SS (LS3, L99) i-1 SPECIFICATIONS

Year	Part Number	OEM HP Rating	HP Gain	Tube Diam	Intercooler Mount	Drive System	Bypass System	Fuel System Upgrade	Fuel Inj. Supplied	Computer/Ignition Modifications	Supercharger Warranty (in months)	CARB E.O.	Foot Notes
2010-15	1GT313-SCI	426/400	55%+	3"	V	add'l 8 rib	ProFlow	pump voltage booster	50 lb/hr	programmer supplied	12, 36 opt. (\$149)	-	O1, O2, O3, O6, O7

2010-15 CAMARO SS COG RACE KIT SPECIFICATIONS

Year	Part Number	OEM HP Rating	HP Gain	Tube Diam	Intercooler Mount	Drive System	Bypass System	Fuel System Upgrade	Fuel Inj. Supplied	Computer/Ignition Modifications	Supercharger Warranty (in months)	CARB E.O.	Foot Notes
2010-15	1GT200-F1-I	-	specify	3"/3.5"	V	Cog	Race	not supplied	no	not supplied	Limited	-	O1, O3, O4, O5, O8, O9, O10
2010-15	1GT200-F1	-	specify	-	-	Cog	Race	not supplied	no	not supplied	Limited	-	O1, O3, O4, O5, O8, O9, O10

CHEVROLET AUTOMOTIVE FOOTNOTES (specific to above applications):

- O1) Model year must be specified
- O2) Due to variability among OEM computers, and the prevalence of custom modifications, dyno tuning may be required
- O3) System ships in extra large box
- O4) Race intercooler upgrades may require modifications
- O5) 2010-15 Cog and 10-rib requires ATI Balancer ATI PP #918635 (not included - specify hardened hub)
- O6) Stage II air inlet and air inlet upgrade package require auxiliary battery bracket relocation (supplied)
- O7) Two-part shipment, additional shipping charges may apply
- O8) Requires coolant hose modifications
- O9) Bracket brace and Kevlar COG belt recommended
- O10) 9.75" and larger head unit requires modification of strut tower and power steering reservoir (10-12), and inner fender

1998-02 CAMARO/FIREBIRD (LS1) SYSTEMS AND KITS

Year	Part Number	Description	Boost Options	HP Gain	Intercooler	Price
1999-02	1GJ214-SCI	High Output Intercooled System with P-1SC-1	5, 7 psi	40-55%	3.5" twin highflow	\$7,399
1998-02	1GJ213-SCI	High Output Intercooled Tuner Kit with P-1SC-1	specify	specify	3.5" twin highflow	\$6,649
1998-02	1GJ204-SCI	Intercooled Serpentine Race Kit with D-1SC (8 rib with spring tensioner)	specify	specify	4.5" twin highflow	\$7,349

1998-02 CAMARO AND FIREBIRD (LS1) OPTIONS	add "-P" to part #	Polished Aluminum Intake Plenum (Replacing rotomold plenum)	blk rotomold std	-	-	+\$225
	add "-H" to part #	Helical gasket for noise reduction (P-1SC-1, D-1SC)	same	same	-	+\$100
	add "-D1SC" to part #	With D-1SC ProCharger (replacing P-1SC-1)	specify	specify	-	+\$250
	add "-D" or "-1" or "-A"	With F-1D, F-1, F-1A ProCharger (replacing D-1SC, Serp Race Kit only)	Race kit only	specify	-	+\$540
	add "-4.5" to part #	Upgrade to 4.5" Twin Highflow intercooler	from 3.5" Twin	-	850 hp max	+\$315
	add "-8R" to part #	8 Rib Drive System Upgrade	specify	specify	-	+\$225
	add "-10R" to part #	10 Rib Drive System Upgrade (race kit only, from 8 rib)	specify	specify	-	+\$225
	add "-3C" to part #	Race Intercooler Upgrade (race kit only, race valve and modifications req'd)	from 4.5" Twin	specify	1,300 hp max	+\$225
	add "-RVR" or "-RVB"	Race Bypass Valve Upgrade (race kit only, specify open or closed valve)	red or black	specify	-	+\$295
add "-ATIPP" to part #	ATI Performance Products Balancer (#918853, 8 rib drive only)	-	-	-	+\$475	
	3GKMM-004	Crank Pin Kit	-	-	-	+\$99

1993-97 CAMARO/FIREBIRD (LT1) SYSTEMS AND KITS

Year	Part Number	Description	Boost Options	HP Gain	Intercooler	Price
1993-97	1GA211-071 / 09I	High Output Intercooled System with P-1SC	7, 9 psi	55-60%	2 core	\$5,999
1993-97	1GA201-SCI	High Output Intercooled Tuner Kit with P-1SC	specify	specify	2 core	\$5,749
1993-97	1GA212-D1SC	Intercooled Serpentine Race Kit with D-1SC (12 rib)	specify	specify	twin highflow	\$6,499

1993-97 CAMARO AND FIREBIRD (LT1) OPTIONS	add "-P" to part #	Polished finish for ProCharger (P-series or D-series)	satin standard	-	-	+\$295
	add "-I" to part #	Polished finish for intake tract	satin standard	-	-	+\$150
	add "-H" to part #	Helical gasket for noise reduction (P-1SC, D-1SC)	same	same	-	+\$100
	add "-D1SC" to part #	With D-1SC ProCharger (replacing P-1SC)	HO kit only	specify	-	+\$470
	add "-D" or "-1" or "-A"	With F-1D, F-1, F-1A ProCharger (replacing D-1SC, Serp Race Kit only)	Race kit only	specify	-	+\$550
	add "-RVR" or "-RVB"	Race Bypass Valve Upgrade (specify open or closed valve)	red or black	specify	-	+\$295
	add "-THF" to part #	Twin Highflow intercooler upgrade	from 2 core	-	750 hp max	+\$495
	MA001I-001	Mass Airflow Massager (required for 96-97 only)	-	-	-	+\$199

1987-92 CAMARO/FIREBIRD TPI (L98) SYSTEMS AND KITS

Year	Part Number	Description	Boost Options	HP Gain	Intercooler	Price
1987*-92	1GC211-09I	High Output Intercooled System with P-1SC	9 psi	65%	2 core	\$5,399
1987*-92	1GC201-SCI	High Output Intercooled Tuner Kit with P-1SC	specify	specify	2 core	\$5,149
1987*-92	1GC201-D1SC	Stage II Intercooled Tuner with D-1SC	specify	specify	3 core	\$5,799

1987-92 CAMARO AND FIREBIRD (L98) OPTIONS	add "-P" to part #	Polished finish for ProCharger (P-series or D-series)	satin standard	-	-	+\$295
	add "-H" to part #	Helical gasket for noise reduction (P-1SC, D-1SC)	same	same	-	+\$100
	add "-D1SC" to part #	With D-1SC ProCharger (replacing P-1SC)	specify	specify	-	+\$470
	add "-3C" to part #	3 core intercooler upgrade	from 2 core	-	825 hp max	+\$345
	add "-I" to part #	Polished finish for intake tract	satin standard	-	-	+\$150
	add "-OF" to part #	Omit FMU (Stage II)	-	-	-	-\$88
	add "-OP" to part #	Omit in-line fuel pump (Stage II)	-	-	-	-\$98

* 1987 model years require Serpentine Accessory Belt Drive System, GM Part #12497698

SPECIFICATIONS (1987-02 F-BODY)

1998-02 CAMARO/FIREBIRD (LS1) SPECIFICATIONS

Year	Part Number	OEM HP Rating	HP Gain	Tube Diam	IC Mount	Drive System	Bypass System	Fuel System Upgrade	Fuel Inj. Supplied	Computer/Ignition Modifications	Supercharger Warranty (in months)	CARB E.O.	Foot Notes
1999-02	1GJ214-SCI	310-325	40-55%	2.5" ea	H	add'l 6 rib	ProFlow	ProPump	38 lb/hr	programmer sup.	12, 36 opt. (\$99)	D-365-6	P1, P9, P10, P11
1998-02	1GJ213-SCI	310-325	specify	2.5" ea	H	add'l 6 rib	ProFlow	not supplied	No	not supplied	12	-	P1, P9, P10, P11, P14
1998-02	1GJ204-SCI	310-325	specify	2.5" ea	H	add'l 8 rib	ProFlow	not supplied	No	not supplied	12	-	P1, P9, P10, P11, P13, P14

1993-97 CAMARO/FIREBIRD (LT1) SPECIFICATIONS

Year	Part Number	OEM HP Rating	HP Gain	Tube Diam	IC Mount	Drive System	Bypass System	Fuel System Upgrade	Fuel Inj. Supplied	Computer/Ignition Modifications	Supercharger Warranty (in months)	CARB E.O.	Foot Notes
1993-97	1GA211-07I/-09I	275-305	55-60%	3"	H	add'l 8 rib	ProFlow	ProPump	not required	not required	12, 36 opt. (\$99)	D-365-3 (93-95)	P1, P2, P3, P4, P5, P16
1993-97	1GA201-SCI	275-305	55-60%	3"	H	add'l 8 rib	ProFlow	not supplied	not required	not required	12	-	P1, P2, P3, P4, P5, P16
1993-97	1GA212-D1SC	275-305	specify	3.5" ea	H	add'l 12 rib	ProFlow	not supplied	No	not supplied	12	-	P1, P2, P3, P5, P6, P8, P14, P16

1987-92 CAMARO/FIREBIRD TPI (L98) SPECIFICATIONS

Year	Part Number	OEM HP Rating	HP Gain	Tube Diam	IC Mount	Drive System	Bypass System	Fuel System Upgrade	Fuel Inj. Supplied	Computer/Ignition Modifications	Supercharger Warranty (in months)	CARB E.O.	Foot Notes
1987-92	1GC211-09I	230-245	65%	3"	H	add'l 8 rib	ProFlow	ProPump	No	not required	12, 36 opt. (\$99) for 9 psi	D-365-3 (88-92)	P1, P12, P16
1987-92	1GC201-SCI	230-245	specify	3"	H	add'l 8 rib	ProFlow	not supplied	No	not required	12	-	P1, P12, P16
1987-92	1GC211-D1SC	230-245	specify	3"	H	add'l 8 rib	ProFlow	ProPump	No	not required	12	-	P1, P12, P16

CHEVROLET/PONTIAC AUTOMOTIVE FOOTNOTES (specific to above applications):

- P1) Model year must be specified
- P2) Mass airflow massager required for '96-97 LT1's (sold separately by ProCharger)
- P3) LT1 F-bodies with traction control will require custom relocation of that module
- P4) 1993 LT1 F-bodies require the purchase of larger fuel injectors or an ignition retard system (sold separately by others)
- P5) May not accommodate all aftermarket balancers
- P6) Modified engines only
- P8) D-1SC, F-1, F-1A modified engines only (air inlet may require modification)
- P9) Pinning the balancer to the crank is recommended; Pin kit for stock balancer not supplied
- P10) Purchase of specific aftermarket harmonic balancer required for 8 rib and 10 rib upgrade, modifications required (ATI PP part #918853) (not included - specify hardened hub)
- P11) Crank pinning is recommended for higher horsepower applications
- P12) 1987 model years require Serpentine Accessory Belt Drive System, GM Part # 12497698
- P13) Race intercooler upgrade requires front bumper modification and requires system to ship in extra large box
- P14) F-series head unit upgrades may require minor modifications
- P15) Due to variability among OEM computers, and the prevalence of custom modifications, dyno tuning may be required
- P16) Special order kit: order form and non-refundable deposit required at time of order—may require additional lead time for processing



2014-17 CHEVROLET SS SYSTEMS AND KITS

Year	Part Number	Description	Boost Options	HP Gain	Intercooler	Price
2014-17	1GW212-SCI	High Output Intercooled System with P-1SC-1	8 psi	50%	2 Core	\$7,499
2014-17	1GW202-SCI	High Output Intercooled Tuner Kit with P-1SC-1	specify	specify	2 Core	\$6,899

2014-17 CHEVROLET SS	add "-B" or "-P" to part #	Black or Polished finish for ProCharger (P-series or D-series)	satin standard	-	-	+\$295
	add "-B" or "-P" to part #	Black or Polished finish for ProCharger (F-series, 9" or 9.75" housing)	satin standard	-	-	+\$325
	add "-BB" or "-PB" to part #	Black or Polished finish for supercharger bracket	satin standard	-	-	+\$250
	add "-H" to part #	Helical gearset for noise reduction (P-1SC-1, P-1X, D-1SC, D-1X)	same	same	-	+\$100
	add "-P1X" to part #	With P-1X ProCharger (replacing P-1SC-1, Systems and Tuner Kits)	same	add'l 10-15+ hp	-	+\$200
	add "-D1SC" to part #	With D-1SC ProCharger (replacing P-1SC-1)	tuner kit only	specify	-	+\$250
	add "-D1X" to part #	With D-1X ProCharger (replacing P-1SC-1, Tuner Kits only)	tuner kit only	specify	-	+\$425
	add "-D" or "-1" or "-A"	With F-1D, F-1, F-1A ProCharger (replacing P-1SC-1)	tuner kit only	specify	-	+\$775
	add "-94" to part #	With F-1A-94 ProCharger (replacing P-1SC-1)	tuner kit only	specify	-	+\$1,100
add "-RVR" or "RVB"	Race Bypass Valve Upgrade (Open only)	red or black	specify	-	+\$295	
add "-3C" to part #	3 core intercooler system upgrade	from 2 core	825 hp max	3" tubing	+\$345	

2008-09 PONTIAC G8 GT SYSTEMS AND KITS

Year	Part Number	Description	Boost Options	HP Gain	Intercooler	Price
2008-09	1GS212-SCI	High Output Intercooled System with P-1SC-1	8 psi	50-55%	2 Core	\$7,399
2008-09	1GS202-SCI	High Output Intercooled Tuner Kit with P-1SC-1	specify	specify	2 Core	\$6,799

2008-09 G8 GT OPTIONS	add "-B" or "-P" to part #	Black or Polished finish for ProCharger (P-series or D-series)	satin standard	-	-	+\$295
	add "-B" or "-P" to part #	Black or Polished finish for ProCharger (F-series, 9" or 9.75" housing)	satin standard	-	-	+\$325
	add "-BB" or "-PB" to part #	Black or Polished finish for supercharger bracket	satin standard	-	-	+\$250
	add "-3C" to part #	3 core intercooler system upgrade	from 2 core	825 hp max	3" tubing	+\$345
	add "-H" to part #	Helical gearset for noise reduction (P-1SC-1, D-1SC)	same	same	-	+\$100
	add "-D1SC" to part #	With D-1SC ProCharger (replacing P-1SC-1)	tuner kit only	specify	-	+\$250
	add "-D" or "-1" or "-A"	With F-1D, F-1, F-1A ProCharger (replacing P-1SC-1)	tuner kit only	specify	-	+\$775
add "-RVR" or "RVB"	Race Bypass Valve Upgrade (Open only)	red or black	specify	-	+\$295	

2004-06 PONTIAC GTO (LS1, LS2) SYSTEMS AND KITS

Year	Part Number	Description	Boost Options	HP Gain	Intercooler	Price
2005-06 (LS2)	1GN312-SCI	High Output Intercooled System with P-1SC-1	7 psi	50%	GTO	\$7,599
2005-06 (LS2)	1GN302-SCI	High Output Intercooled Tuner Kit with P-1SC-1	specify	specify	GTO	\$6,799
2005-06 (LS2)	1GN313-F1A	Intercooled Serpentine Race Kit with F-1D, F-1, or F-1A	specify	specify	GTO	\$7,699
2004 (LS1)	1GN212-SCI	High Output Intercooled System with P-1SC-1	7 psi	50%	GTO	\$7,599
2004 (LS1)	1GN202-SCI	High Output Intercooled Tuner Kit with P-1SC-1	specify	specify	GTO	\$6,799
2004 (LS1)	1GN213-F1A	Intercooled Serpentine Race Kit with F-1D, F-1, or F-1A	specify	specify	GTO	\$7,699

2004-06 GTO (LS1, LS2) OPTIONS	add "-P" to part #	Black or Polished finish for ProCharger (P-series or D-series)	satin standard	-	-	+\$295
	add "-BB" or "-PB" to part #	Black or Black or Polished finish for supercharger bracket	satin standard	-	-	+\$250
	add "-H" to part #	Helical gearset for noise reduction (P-1SC-1, D-1SC)	same	same	-	+\$100
	add "-D1SC" to part #	With D-1SC ProCharger (replacing P-1SC-1)	tuner kit only	specify	-	+\$250
	add "-RVR" or "RVB"	Race Bypass Valve Upgrade (specify open or closed valve)	red or black	specify	-	+\$295
add "-3R" to part #	Race Intercooler Upgrade (1,000 hp, see Footnote Q8)	-	specify	-	+\$699	

SPECIFICATIONS (2004-17 SS, G8, GTO)

2014-17 CHEVROLET SS SPECIFICATIONS

Year	Part Number	OEM HP Rating	HP Gain	Tube Diam	Intercooler Mount	Drive System	Bypass System	Fuel System Upgrade	Fuel Inj. Supplied	Computer/Ignition Modifications	Supercharger Warranty (in months)	CARB E.O.	Foot Notes
2014-17	1GW212-SCI	415	50%	3"	V	add'l 8 rib	ProFlow	not required	50 lb/hr	programmer sup.	12, 36 opt. (\$99)	-	Q1, Q2, Q3
2014-17	1GW202-SCI	415	specify	3"	V	add'l 8 rib	ProFlow	not supplied	no	not supplied	12	-	Q1, Q2

2008-09 PONTIAC G8 GT SPECIFICATIONS

Year	Part Number	OEM HP Rating	HP Gain	Tube Diam	Intercooler Mount	Drive System	Bypass System	Fuel System Upgrade	Fuel Inj. Supplied	Computer/Ignition Modifications	Supercharger Warranty (in months)	CARB E.O.	Foot Notes
2008-09	1GS212-SCI	361	50-55%	3"	V	add'l 8 rib	ProFlow	not required	50 lb/hr	programmer sup.	12, 36 opt. (\$99)	-	Q1, Q2, Q3, Q7, Q9, Q11
2008-09	1GS202-SCI	361	specify	3"	V	add'l 8 rib	ProFlow	not supplied	no	not supplied	12	-	Q1, Q2, Q7, Q9, Q12

2004-2006 PONTIAC GTO (LS1, LS2) SPECIFICATIONS

Year	Part Number	OEM HP Rating	HP Gain	Tube Diam	Intercooler Mount	Drive System	Bypass System	Fuel System Upgrade	Fuel Inj. Supplied	Computer/Ignition Modifications	Supercharger Warranty (in months)	CARB E.O.	Foot Notes
2005-06	1GN312-SCI	400	50%	3"	V	add'l 8 rib	ProFlow	not required	57 lb/hr	programmer sup.	12, 36 opt. (\$99)	-	Q1, Q2, Q3, Q4, Q5, Q6, Q8
2005-06	1GN302-SCI	400	specify	3"	V	add'l 8 rib	ProFlow	not supplied	No	not supplied	12	-	Q1, Q2, Q4, Q5, Q6, Q8
2005-06	1GN313-F1A	-	specify	3"	V	add'l 8 rib	Race	not supplied	No	not supplied	12	-	Q1, Q2, Q4, Q5, Q6, Q8, Q10
2004	1GN212-SCI	350	50%	3"	V	add'l 8 rib	ProFlow	not required	38 lb/hr	programmer sup.	12, 36 opt. (\$99)	D-365-6	Q1, Q2, Q4, Q5, Q6, Q8
2004	1GN202-SCI	350	specify	3"	V	add'l 8 rib	ProFlow	not supplied	No	not supplied	12	-	Q1, Q2, Q4, Q5, Q6, Q8
2004	1GN213-F1A	-	specify	3"	V	add'l 8 rib	Race	not supplied	No	not supplied	12	-	Q1, Q2, Q4, Q5, Q6, Q8, Q10

CHEVROLET/PONTIAC AUTOMOTIVE FOOTNOTES (specific to above applications):

- Q1) Model year must be specified
- Q2) Pinning the balancer to the crank is recommended; Pin kit for stock balancer is supplied
- Q3) Due to variability among OEM computers, and the prevalence of custom modifications, dyno tuning may be required
- Q4) Specify stock or aftermarket balancer, and stock or overdrive diameter crank pulley (if aftermarket balancer, requires ATI PP part #918853, not included - specify hardened hub)
- Q5) May require transmission cooling line modification
- Q6) System ships in extra large box
- Q7) 2009 G8 may require 2008 Balancer
- Q8) Requires modification of front bumper (GTO race intercooler only)
- Q9) Requires modifications for 3 core upgrade
- Q10) Race intercooler recommended above 600 HP
- Q11) Complete systems are compatible with G8 GT models only
- Q12) Tuner Kits are compatible with G8 GT models, and GXP models with modifications



CARBURETED AND AFTERMARKET EFI CHEVROLET SB AND BB SERPENTINE KITS

Year	Part Number	Description	Boost Options	HP Gain	Intercooler	Price
specify	1CX100-P600B*	High Output with P600B (8 rib)	specify	specify	-	\$3,399
specify	1CX100-P1SC*	High Output with P-1SC (8 rib)	specify	specify	-	\$3,749
specify	1CX100-P1SC-I*	High Output Intercooled with P-1SC (8 rib)	specify	specify	2 core (550hp)	\$4,799
specify	1CX100-D1*	High Output with D-1 (12 rib)	specify	specify	-	\$4,399
specify	1CX100-D1SC*	High Output with D-1SC (12 rib)	specify	specify	-	\$4,399
specify	1CX100-D1SC-I*	High Output Intercooled with D-1SC (12 rib)	specify	specify	3 core (825hp)	\$5,699
specify	1CX100-F1D/F1/F1A*	High Output with F-1D, F-1, F-1A (12 rib)	specify	specify	-	\$5,449
specify	1CX100-F1D-I/F1-I/F1A-I*	High Output Intercooled with F-1D, F-1, F-1A, F-1A-94 (12 rib)	specify	specify	Sht mtl 3C (950hp)	\$6,749
specify	1CX100-F1C/F1R*	High Output with F-1C, F-1R, F-1A-94 (12 rib)	specify	specify	-	\$5,799
specify	1CX100-F1C-I/F1R-I*	High Output Intercooled with F-1C, F-1R (12 rib)	specify	specify	Sht mtl 3C (1050hp)	\$7,149
specify	1CX100-F1X	High Output with F-1X (12 rib)	specify	specify	-	\$6,149
specify	1CX100-F1X-I*	High Output Intercooled with F-1X (12 rib)	specify	specify	Sht mtl (1300hp)	\$7,849
specify	1CX100-F2*	High Output with F-2 (12 rib)	specify	specify	-	\$6,449
specify	1CX100-F2-I*	High Output Intercooled with F-2 (12 rib)	specify	specify	Sht mtl (1300hp)	\$8,149

CARB & AFTERMARKET EFI CHEVY SB AND BB SERPENTINE KIT OPTIONS	add "-B" or "-P" to part #	Black or Polished finish for ProCharger (P-series or D-series)	satin standard	-	-	+\$295
	add "-B" or "-P" to part #	Black or Polished finish for ProCharger (F-series 9"-9.75" housing)	satin standard	-	-	+\$325
	add "-B" or "-P" to part #	Black or Polished finish for ProCharger (F-series, 10.5" housing)	satin standard	-	-	+\$375
	add "-BB" or "-PB" to part #	Polished finish for main bracket(s) and tensioner	satin standard	-	-	+\$250
	add "-BSB" or "-PSB" to part #	Black or Polished finish for serpentine accessory drive bracket	satin standard	-	-	+\$200
	add "-BC" or "-PC" to part #	Black or Polished finish for carburetor bonnet	satin standard	-	-	+\$90
	add "-H" to part #	Helical gearset for noise reduction (P-1SC, P-1X, D-1SC, D-1X)	same	-	-	+\$100
	add "-P1X" to part #	With P-1X ProCharger (replacing P-1SC)	same	add'l 10-15+ hp	-	+\$420
	add "-D1X" to part #	With D-1X ProCharger (replacing P-1SC)	tuner kit only	specify	-	+\$645
	add "-D1X" to part #	With D-1X ProCharger (replacing D-1SC)	tuner kit only	specify	-	+\$175
	add "-CB" to part #	Competition Carb Bonnet Upgrade	from standard	-	-	+\$35
	add "-CB" to part #	Competition Carb Bonnet Upgrade	from low-profile	-	-	+\$60
	1CX110-SC-SBA*	Serpentine Accessory Drive SBC/BBC (time of purchase, see R8)	req Sanden a/c	-	-	+\$829
	1CX110-SC-SB*	Serpentine Accessory Drive SBC/BBC (time of purchase, see R8)	without a/c	-	-	+\$829
	AI003A-001	3 core intercooler (825 hp)	from non-ic kit	3" in/outlet	-	+\$975
	AI003A-002	Sheet metal 3 core race intercooler (950 hp)	from non-ic kit	3" in/outlet	-	+\$1,170
	AI003A-005	Sheet metal 3 core race intercooler (1050 hp)	from non-ic kit	3.5" in/outlet	-	+\$1,350
	AI045A-001	Sheet metal 3 core race intercooler (1300 hp)	from non-ic kit	3.5" in/outlet	-	+\$1,586
	AI006A-001	Sheet metal 3 core race intercooler (1550 hp)	from non-ic kit	4" in/outlet	-	+\$2,075
	3CASS-002	ProFlow bypass valve kit	-	-	-	+\$244
	AV006A-003	Bullet Bypass/Anti-Surge Valve - Closed	-	-	-	+\$349
	AV006A-004	Bullet Bypass/Anti-Surge Valve - Open	-	-	-	+\$349
	3FASS-00X	Race Bypass Valve, Open or Closed (aluminum or steel flange)	red or black	-	-	+\$469
FV001I-BST	Boost sensitive fuel pressure regulator (EFI or Carb)	-	-	-	+\$259	
FV002I-BST	Boost sensitive fuel pressure regulator (Carb, 1000hp capable)	-	-	-	+\$279	
FP001I-002	ProPump fuel pump 700 hp	-	-	-	+\$299	
FP001I-006	High Performance 1000 hp electric fuel pump	-	-	-	+\$399	
AB00XX-000	BB/SB p/s reloc. kit (remote reservoir) pump not included (V-belt)	for Jayco	-	-	+\$269	
AB007A-085	SBC Repositioning bracket	-	-	-	+\$89	
AB008A-065	BBC Repositioning bracket	-	-	-	+\$99	

*Replace "CX" in part number with "CA" for Small Block applications, "CB" for Big Block applications

SPECIFICATIONS (CARB & AFTERMARKET EFI SB/BB)

CARBURETED AND AFTERMARKET EFI CHEVROLET SB AND BB SERPENTINE KIT SPECIFICATIONS

Year	Part Number	Stock HP	HP Gain	Tube Diam	Carb Hat	Drive System	Bypass Valve	Power Steering Relocation Kit (optional)	A/C Installation Kit (optional)	SC Warranty (in months)	Tubing Supplied	Foot Notes
specify	1CX100-P600B*	N/A	specify	-	low profile	add'l 8 rib	Sold separately	Jayco Remote Reservoir	Yes	12	-	R1, R2, R3, R6, R7, R8
specify	1CX100-P1SC*	N/A	specify	-	low profile	add'l 8 rib	Sold separately	Jayco Remote Reservoir	Yes	12	-	R1, R2, R3, R6, R7, R8
specify	1CX100-P1SC-J*	N/A	specify	3"	std	add'l 8 rib	ProFlow	Jayco Remote Reservoir	Yes	12	Yes	R1, R2, R4, R6, R7, R8
specify	1CX100-D1*	N/A	specify	-	std	add'l 12 rib	Sold separately	Jayco Remote Reservoir	Yes	12	-	R1, R2, R3, R6, R7, R8
specify	1CX100-D1SC*	N/A	specify	-	std	add'l 12 rib	Sold separately	Jayco Remote Reservoir	Yes	12	-	R1, R2, R3, R6, R7, R8
specify	1CX100-D1SC-J*	N/A	specify	3"	std	add'l 12 rib	ProFlow	Jayco Remote Reservoir	Yes	12	Yes	R1, R2, R4, R6, R7, R8
specify	1CX100-F1D/F1A*	N/A	specify	-	std	add'l 12 rib	Race Valve	Jayco Remote Reservoir	Yes	12	-	R1, R2, R5, R6, R7, R8
specify	1CX100-F1D-I/F1-I/F1A-I*	N/A	specify	3"	std	add'l 12 rib	Race Valve	Jayco Remote Reservoir	Yes	12	Yes	R1, R2, R4, R5, R6, R7, R8
specify	1CX100-F1C/F1R*	N/A	specify	-	std	add'l 12 rib	Race Valve	Jayco Remote Reservoir	Yes	12	-	R1, R2, R5, R6, R7, R8
specify	1CX100-F1C-I/F1R-I*	N/A	specify	3.5"	std	add'l 12 rib	Race Valve	Jayco Remote Reservoir	Yes	12	Yes	R1, R2, R4, R5, R6, R7, R8
specify	1CX100-F1X*	N/A	specify	3.5"	std	add'l 12 rib	Race Valve	Jayco Remote Reservoir	Yes	12	-	R1, R2, R5, R6, R7, R8
specify	1CX100-F1X-I*	N/A	specify	3.5"	std	add'l 12 rib	Race Valve	Jayco Remote Reservoir	Yes	12	Yes	R1, R2, R4, R5, R6, R7, R8
specify	1CX100-F2*	N/A	specify	-	std	add'l 12 rib	Race Valve	Jayco Remote Reservoir	Yes	12	-	R1, R2, R5, R6, R7, R8
specify	1CX100-F2-I*	N/A	specify	3.5"	std	add'l 12 rib	Race Valve	Jayco Remote Reservoir	Yes	12	Yes	R1, R2, R4, R5, R6, R7, R8

*Replace "X" in part number with "A" for Small Block applications, "B" for Big Block applications

CHEVROLET/GM AUTOMOTIVE FOOTNOTES (specific to above applications):

- R1) Carbureted systems require Holley 4150 series or similar blow-through carburetor (sold separately by others) and fuel system upgrade (sold by ProCharger)
- R2) Must provide own P/S pump with remote reservoir, GM Type II Pump (both Serpentine and V-Groove)
- R3) Purchase of bypass valve recommended above 8 psi, or with intercooler (sold separately by ProCharger)
- R4) Universal Tubing Kit included, not designed for a specific vehicle
- R5) Cog may be required above 1,000 hp
- R6) A/C option on serpentine accessory drive requires Sanden A/C compressor 508/SD5H14 (sold separately by others)
- R7) Serpentine accessory drive requires reverse rotation water pump: SB requires 1984-91 Corvette reverse rotation water pump (sold separately by others), BB requires reverse rotation BB water pump (Edelbrock part #8854, sold separately by others); V-Groove accessory drive requires standard rotation, long water pump (SB and BB)
- R8) Alternator placement with serpentine accessory drive is not compatible with some aftermarket EFI systems; designed to work with Delco style alternator with 6.61" center to center mounting



CARBURETED AND AFTERMARKET EFI CHEVROLET SB AND BB COG RACE KITS

Year	Part Number	Description	Boost Options	HP Gain	Intercooler	Price
specify	1CX200-F1D/F1/F1A*	Cog Race Kit with F-1D, F-1, F-1A	specify	specify	-	\$5,649
specify	1CX200-F1D-I/F1-I/F1A-I*	Intercooled Cog Race Kit with F-1D, F-1, or F-1A	specify	specify	Sht mtl 3C (950hp)	\$6,899
specify	1CX200-F1A94/F1C/F1R*	Cog Race Kit with F-1A-94, F-1C, F-1R	specify	specify	-	\$6,099
specify	1CX200-F1A94-I/F1C-I/F1R-I*	Intercooled Cog Race Kit with F-1A-94, F-1C or F-1R	specify	specify	Sht mtl 3C (1050hp)	\$7,299
specify	1CX200-F1X*	Cog Race Kit with F-1X	specify	specify	-	\$6,699
specify	1CX200-F1X-I*	Intercooled Cog Race Kit with F-1X	specify	specify	Sht mtl (1300hp)	\$8,349
specify	1CX200-F2*	Cog Race Kit with F-2	specify	specify	-	\$6,799
specify	1CX200-F2-I*	Intercooled Cog Race Kit with F-2	specify	specify	Sht mtl (1300hp)	\$8,449
specify	1CX200-F3A-spec*	Cog Race Kit with F-3R-121	specify	specify	-	\$7,699
specify	1CX200-F3R-spec*	Cog Race Kit with F-3R-130 or -136	specify	specify	-	\$7,899
specify	1CX200-F1XR*	Reverse Rotation Cog Race Kit with F-1X	specify	specify	-	\$7,049
specify	1CX200-F2R*	Reverse Rotation Cog Race Kit with F-2	specify	specify	-	\$7,149
specify	1CX200-F3AR-spec*	Reverse Rotation Cog Race Kit with F-3R-121	specify	specify	-	\$8,299
specify	1CX200-F3RR-spec*	Reverse Rotation Cog Race Kit with F-3R-130 or -136	specify	specify	-	\$8,599
CARB & AFTERMARKET EFI CHEVY SB AND BB COG RACE KIT OPTIONS	add "-B" or "-P" to part #	Black or Polished finish for ProCharger (P-series or D-series)	satin standard	-	-	+\$295
	add "-B" or "-P" to part #	Black or Polished finish for ProCharger (F-series, 9" or 9.75" housing)	satin standard	-	-	+\$325
	add "-B" or "-P" to part #	Black or Polished finish for ProCharger (F-series, 10.5" housing)	satin standard	-	-	+\$375
	add "-BB" or "-PB" to part #	Black or Polished finish for main bracket and tensioner	satin standard	-	-	+\$250
	add "-BSB" or "-PSB" to part #	Black or Polished finish for serpentine accessory drive bracket	satin standard	-	-	+\$200
	add "-BC" or "-PC" to part #	Black or Polished finish for carburetor bonnet	satin standard	-	-	+\$90
	add "-112"	With F-1X-12/F-3R-112 (replacing F-3R-121)	specify	-	-	-\$300
	3FASS-00X	Race Bypass Valve, open or closed (RaceDrive, included in Race kits)	red or black	-	-	+\$469
	add "-PRV" to part #	ProRace Bypass Valve (From Race Valve, v-band clamp mounting)	specify	-	-	+\$229
	add "-PRV" to part #	ProRace Bypass Valve (v-band clamp mounting, for RaceDrive)	specify	-	-	+\$699
	add "-CB" to part #	Competition Carb Bonnet Upgrade 4150 (at time of kit purchase)	from standard	-	-	+\$40
	add "-DCP"	Competition Carb Bonnet Upgrade 4500 polished finish (at time of kit purchase)	from standard	-	-	+\$160
	add "-DCB"	Competition Carb Bonnet Upgrade 4500 black finish (at time of kit purchase)	from standard	-	-	+\$200
	1CX210-SCA*	Serpentine Accessory Drive SBC/BBC (at time of kit purchase)	req Sanden a/c	-	-	+\$829
	1CX210-SC*	Serpentine Accessory Drive SBC/BBC (at time of kit purchase)	without a/c	-	-	+\$829
	AI003A-002	Sheet metal 3 core race intercooler (950 hp)	from non-ic kit	3" in/outlet	-	+\$1,170
	AI003A-005	Sheet metal 3 core race intercooler (1050 hp)	from non-ic kit	3.5" in/outlet	-	+\$1,350
	AI045A-001	Sheet metal 3 core race intercooler (1300 hp)	from non-ic kit	3.5" in/outlet	-	+\$1,586
	AI006A-001	Sheet metal 3 core race intercooler (1550 hp)	from non-ic kit	4" in/outlet	-	+\$2,075
	WI1005A-003	Air/water race intercooler (race use only)	-	1,250 hp max	-	+\$1,699
WI1005A-001	Air/water race intercooler (race use only)	-	1,800 hp max	-	+\$2,199	
WI1005A-002	Air/water race intercooler (race use only)	-	2,500+ hp max	-	+\$2,699	
AB007A-085	SB Repositioning bracket	-	-	-	+\$89	
AB008A-065	BB Repositioning bracket	-	-	-	+\$99	
FV002I-BST	Boost sensitive fuel pressure regulator (Carb only, 1000 hp compatible)	-	-	-	+\$279	
FP001I-006	High Performance 1000 hp electric fuel pump	-	-	-	+\$399	

*Replace "CX" in part number with "CA" for Small Block applications or "CB" for Big Block applications

FOR CRANKDRIVE, SEE PAGE 86

FOR PASSENGER REVERSE MOUNTING SEE PAGE 46

SPECIFICATIONS (CARB & AFTERMARKET EFI SB/BB)

CARBURETED AND AFTERMARKET EFI CHEVROLET SB AND BB COG RACE SPECIFICATIONS

Year	Part Number	Stock HP	HP Gain	Tube Diam	Carb Hat	Drive System	Bypass Valve	Power Steering Relocation Kit (optional)	A/C Installation Kit (optional)	SC Warranty (in months)	Tubing Supplied	Foot Notes
specify	1CX200-F1D/F1/F1A*	N/A	specify	-	Standard	8 x 50 mm cog	Race Valve	Jayco Remote Reservoir	Yes	Limited	-	S1, S3, S4, S5, S6, S7
specify	1CX200-F1D-I/F1-I/F1A-I*	N/A	specify	3"	Standard	8 x 50 mm cog	Race Valve	Jayco Remote Reservoir	Yes	Limited	Yes	S1, S2, S3, S4, S5, S6, S7
specify	1CX200-F1A94/F1C/F1R*	N/A	specify	-	Standard	8 x 50 mm cog	Race Valve	Jayco Remote Reservoir	Yes	Limited	-	S1, S3, S4, S5, S6, S7
specify	1CX200-F1A94-I/F1C-I/F1R-I*	N/A	specify	3.5"	Standard	8 x 50 mm cog	Race Valve	Jayco Remote Reservoir	Yes	Limited	Yes	S1, S2, S3, S4, S5, S6, S7
specify	1CX200-F1X*	N/A	specify	-	Standard	8 x 50 mm cog	Race Valve	Jayco Remote Reservoir	Yes	Limited	-	S1, S3, S4, S5, S6, S7
specify	1CX200-F1X-I*	N/A	specify	3.5"	Standard	8 x 50 mm cog	Race Valve	Jayco Remote Reservoir	Yes	Limited	Yes	S1, S2, S3, S4, S5, S6, S7
specify	1CX200-F2*	N/A	specify	-	Standard	8 x 50 mm cog	Race Valve	Jayco Remote Reservoir	Yes	Limited	-	S1, S3, S4, S5, S6, S7
specify	1CX200-F2-I*	N/A	specify	3.5"	Standard	8 x 50 mm cog	Race Valve	Jayco Remote Reservoir	Yes	Limited	Yes	S1, S2, S3, S4, S5, S6, S7
specify	1CX200-F3A-spec*	N/A	specify	-	-	14 x 55 mm cog	Race Valve	-	-	Limited	-	-
specify	1CX200-F3R-spec*	N/A	specify	-	-	14 x 55 mm cog	Race Valve	-	-	Limited	-	-
specify	1CX200-F1XR*	N/A	specify	-	-	8 x 75 mm cog	Race Valve	-	-	Limited	-	-
specify	1CX200-F2R*	N/A	specify	-	-	8 x 75 mm cog	Race Valve	-	-	Limited	-	-
specify	1CX200-F3AR-spec*	N/A	specify	-	-	8 x 75 mm cog	Race Valve	-	-	Limited	-	-
specify	1CX200-F3RR-spec*	N/A	specify	-	-	8 x 75 mm cog	Race Valve	-	-	Limited	-	-

*Replace "X" in part number with "A" for Small Block applications or "B" for Big Block applications

CHEVROLET/GM AUTOMOTIVE FOOTNOTES (specific to above applications):

- S1) Carbureted systems require Holley 4150 series or similar blow-through carburetor (sold separately by others) and fuel system upgrade (sold by ProCharger and others)
- S2) Universal Intercooler Tubing Kit included, not designed for a specific vehicle
- S3) Electric water pump recommended with V-belt; Mechanical water pump recommended for Serpentine (must use short style pump)
- S4) Must provide own P/S pump with remote reservoir, GM Type II Pump (both Serpentine and V-Groove)
- S5) A/C option on serpentine accessory drive requires Sanden A/C compressor 508/SD5H14 (sold separately by others)
- S6) Serpentine accessory drive requires reverse rotation water pump: SB requires 1984-91 Corvette reverse rotation water pump (sold separately by others), BB requires reverse rotation BB water pump (Edelbrock part #8854, sold separately by others)
- S7) Alternator placement with serpentine accessory drive is not compatible with some aftermarket EFI systems; designed to work with Delco style alternator with 6.61" center to center mounting



LS ENGINE SWAP SERPENTINE KITS (EFI AND CARBURETED)

Year	Part Number	Description	Boost Options	HP Gain	Intercooler	Price
specify	1LS100-P1SC1	High Output with P-1SC-1	specify	specify	-	\$4,449
specify	1LS100-P1SC1-I	High Output with Intercooled P-1SC-1	specify	specify	2 core (550 hp)	\$5,249
specify	1LS100-P1X	High Output with P-1X	specify	specify	-	\$4,649
specify	1LS100-P1X-I	High Output with Intercooled P-1X	specify	specify	2 core (550 hp)	\$5,449
specify	1LS100-D1SC	High Output with D-1SC	specify	specify	-	\$4,699
specify	1LS100-D1SC-I	High Output with Intercooled D-1SC	specify	specify	3 core (825 hp)	\$5,899
specify	1LS100-D1X	High Output with D-1X	specify	specify	-	\$4,899
specify	1LS100-D1X-I	High Output with Intercooled D-1X	specify	specify	3 core (825 hp)	\$5,999
specify	1LS100-F1D/F1/F1A	High Output with F-1D, F-1, or F-1A	specify	specify	-	\$5,749
specify	1LS100-F1D-I/F1-I/F1A-I	High Output with Intercooled F-1D, F-1, or F-1A	specify	specify	Sht mtl 3C (950 hp)	\$6,999
specify	1LS100-F1A94/F1C/F1R	High Output with F-1A-94, F-1C or F-1R	specify	specify	-	\$6,099
specify	1LS100-F1A94-I/F1C-I/F1R-I	High Output with Intercooled F-1A-94, F-1C or F-1R	specify	specify	Sht mtl 3C (1050 hp)	\$7,449

LS ENGINE SWAP COG RACE KITS (EFI AND CARBURETED)

Year	Part Number	Description	Boost Options	HP Gain	Intercooler	Price
specify	1LS200-F1D/F1/F1A	Cog Kit with F-1D, F-1, or F-1A	specify	specify	-	\$5,699
specify	1LS200-F1D-I/F1-I/F1A-I	Cog Kit with Intercooled F-1D, F-1, or F-1A	specify	specify	Sht mtl 3C (950 hp)	\$6,899
specify	1LS200-F1A94/F1C/F1R	Cog Kit with F-1A-94, F-1C or F-1R	specify	specify	-	\$6,049
specify	1LS200-F1A94-I/F1C-I/F1R-I	Cog Kit with Intercooled F-1A-94, F-1C or F-1R	specify	specify	Sht mtl 3C (1050 hp)	\$7,349
specify	1LS200-F1X	Cog Kit with F-1X	specify	specify	-	\$6,649
specify	1LS200-F1X-I	Cog Kit with Intercooled F-1X	specify	specify	Sht mtl 3C (1300 hp)	\$8,199
specify	1LS200-F2	Cog Kit with F-2	specify	specify	-	\$6,749
specify	1LS200-F2-I	Cog Kit with Intercooled F-2	specify	specify	Sht mtl 3C (1300 hp)	\$8,299

LS ENGINE SWAP KIT OPTIONS	add "-B" or "-P" to part #	Black or Polished finish for ProCharger (P-series or D-series)	satin standard	-	-	+\$295
	add "-B" or "-P" to part #	Black or Polished finish for ProCharger (F-series 9"-9.75" housing)	satin standard	-	-	+\$325
	add "-B" or "-P" to part #	Black or Polished finish for ProCharger (F-series, 10.5" housing)	satin standard	-	-	+\$375
	add "-BB" or "-PB" to part #	Black or Polished finish for main bracket and tensioner	satin standard	-	-	+\$250
	add "-BC" or "-PC" to part #	Black or Polished finish for carburetor bonnet	satin standard	-	-	+\$90
	add "-BAB" or "-PAB"	Black or Polished finish for alternator bracket	satin standard	-	-	+\$152
	add "-BPB" or "-PPB"	Black or Polished finish for power steering bracket	satin standard	-	-	+\$159
	add "-H" to part #	Helical gearset for noise reduction (P-1SC-1, P-1X, D-1SC, D-1X)	same	same	-	+\$100
	AM006A-001	Low Profile Carburetor Bonnet (3" inlet, 2" height)	-	-	-	+\$180
	AM009A-001	Standard Carburetor Bonnet (3.5" inlet, 2.75" height)	-	-	-	+\$199
	AM001A-001	Competition Carburetor Bonnet (3.5" inlet, 4.15" height)	-	-	-	+\$240
	specify	Non-intercooled Carburetor Tubing Kit (3" or 3.5")	-	-	-	specify
	add "-12R" to part #	12-Rib Drive System Upgrade (from 8 rib, serpentine kits only)	from 8 rib	-	-	+\$152
	add "-ATIPP" to part #	ATI Performance Products Balancer (#918853)	-	-	-	+\$475
	3GKMM-004	Crank Pin Kit	-	-	-	+\$99
	3LSAT-002	Alternator bracket with tensioner	-	-	-	+\$520
	3LSPS-001	Power steering bracket (requires GM pump, #21997867)	-	-	-	+\$229
	3LSPS-002	Power steering delete bracket	-	-	-	+\$202
	3CASS-002	ProFlow Bypass Valve Kit	-	-	-	+\$244
	AV006A-00X	Bullet Bypass/Anti-Surge Valve, (open or closed)	from ProFlow	-	-	+\$105
	3FASS-00X	Race Bypass Valve Open or Closed (specify alum. or steel flange - Red or Black)	from ProFlow	-	-	\$295
	AI003A-001	3 core intercooler (825 hp)	from non-ic kit	3" in/outlet	-	+\$975
AI003A-002	Sheet metal 3 core race intercooler (950 hp)	from non-ic kit	3" in/outlet	-	+\$1,170	
AI003A-005	Sheet metal 3 core race intercooler (1050 hp)	from non-ic kit	3.5" in/outlet	-	+\$1,350	
AI045A-001	Sheet metal 3 core race intercooler (1300 hp)	from non-ic kit	3.5" in/outlet	-	+\$1,586	
AI006A-001	Sheet metal 3 core race intercooler (1550 hp)	from non-ic kit	4" in/outlet	-	+\$2,075	
FP0011-006	High Performance 1000 hp electric fuel pump	-	-	-	+\$399	

FOR CRANKDRIVE, SEE PAGE 86

SPECIFICATIONS (LS ENGINE SWAP)

LS ENGINE SWAP SERPENTINE SPECIFICATIONS

Year	Part Number	Stock HP	HP Gain	Tube Diam	Carb Hat	Drive System	Bypass Valve	Power Steering Bracket (optional)	Alternator Bracket (optional)	SC Warranty (in months)	Tubing Supplied	Foot Notes
specify	1LS100-P1SC1	N/A	specify	-	optional	8 rib	ProFlow	yes	yes	12	-	all
specify	1LS100-P1SC1-I	N/A	specify	3"	optional	8 rib	ProFlow	yes	yes	12	yes	all
specify	1LS100-P1X	N/A	specify	-	optional	8 rib	ProFlow	yes	yes	12	-	all
specify	1LS100-P1X-I	N/A	specify	3"	optional	8 rib	ProFlow	yes	yes	12	yes	all
specify	1LS100-D1SC	N/A	specify	-	optional	8 rib	ProFlow	yes	yes	12	-	all
specify	1LS100-D1SC-I	N/A	specify	3"	optional	8 rib	ProFlow	yes	yes	12	yes	all
specify	1LS100-D1X	N/A	specify	-	optional	8 rib	ProFlow	yes	yes	12	-	all
specify	1LS100-D1X-I	N/A	specify	3"	optional	8 rib	ProFlow	yes	yes	12	yes	all
specify	1LS100-F1D/F1/F1A	N/A	specify	-	optional	8 rib	Race Valve	yes	yes	12	-	all
specify	1LS100-F1D-I/F1-I/F1A-I	N/A	specify	3"	optional	8 rib	Race Valve	yes	yes	12	yes	all
specify	1LS100-F1A94/F1C/F1R	N/A	specify	-	optional	8 rib	Race Valve	yes	yes	12	-	all
specify	1LS100-F1A94-I/F1C-I/F1R-I	N/A	specify	3.5"	optional	8 rib	Race Valve	yes	yes	12	yes	all

LS ENGINE SWAP COG RACE SPECIFICATIONS

Year	Part Number	Stock HP	HP Gain	Tube Diam	Carb Hat	Drive System	Bypass Valve	Power Steering Bracket (optional)	Alternator Bracket (optional)	SC Warranty (in months)	Tubing Supplied	Foot Notes
specify	1LS200-F1D/F1/F1A	N/A	specify	-	optional	8 x 50 mm cog	Race Valve	yes	yes	Limited	-	all
specify	1LS200-F1D-I/F1-I/F1A-I	N/A	specify	3"	optional	8 x 50 mm cog	Race Valve	yes	yes	Limited	yes	all
specify	1LS200-F1A94/F1C/F1R	N/A	specify	-	optional	8 x 50 mm cog	Race Valve	yes	yes	Limited	-	all
specify	1LS200-F1A94-I/F1C-I/F1R-I	N/A	specify	3.5"	optional	8 x 50 mm cog	Race Valve	yes	yes	Limited	yes	all
specify	1LS200-F1X	N/A	specify	-	optional	8 x 50 mm cog	Race Valve	yes	yes	Limited	-	all
specify	1LS200-F1X-I	N/A	specify	3.5"	optional	8 x 50 mm cog	Race Valve	yes	yes	Limited	yes	all
specify	1LS200-F2	N/A	specify	-	optional	8 x 50 mm cog	Race Valve	yes	yes	Limited	-	all
specify	1LS200-F2-I	N/A	specify	3.5"	optional	8 x 50 mm cog	Race Valve	yes	yes	Limited	yes	all

COMPATIBLE GM ACCESSORIES

Description	GM Part #	OEM Vehicle Source
Power Steering Pump	21997867	2004-2007 Cadillac CTS
Power Steering Pulley	12568997	2004-2007 Cadillac CTS
Alternator	19244751	1999-2013 GM Truck 4.8/5.3/6.0
A/C Compressor	92175482	1998-2002 LS1 F-Body
A/C Bracket	92066950	1998-2002 LS1 F-Body
A/C Belt	---	Napa # 25-040430
A/C Belt Tensioner	12595289	---
Water Pump	89017593	1998-2002 LS1 F-Body

(Auto part stores can use these to cross reference other compatible brands)

LS ENGINE SWAP FOOTNOTES (specific to above applications):

- T1) Requires ATI Performance Products balancer (LS3/LS2/LS1 part #918853, LS7 part #918620) (not supplied - specify hardened hub)
- T2) Specify with or without power steering when using ProCharger Accessory Brackets
- T3) Pinning of the crank pulley is recommended
- T4) Compatible with mechanical or electric water pump
- T5) Designed to work with Muscle Rods motor mounts or comparable (application dependent, sold separately by others)
- T6) Not compatible with Corvette-style water pump
- T7) Specify iron block, aluminum block and tall deck
- T8) LS7 engine requires modifications (not supplied)
- T9) Not a direct bolt-on for VVT engines



PASSENGER SIDE LSx REVERSE ENGINE SWAP KIT

Year	Part Number	Description	Boost Options	HP Gain	Intercooler	Price
specify	1GQ400-P1SC-1	High Output with P-1SC-1	specify	specify	-	\$4,449
specify	1GQ400-P1SC-I	High Output with Intercooled P-1SC-1	specify	specify	2 core (550hp)	\$5,249
specify	1GQ400-P1X	High Output with P-1X	specify	specify	-	\$4,649
specify	1GQ400-P1X-I	High Output with Intercooled P-1X	specify	specify	2 core (550hp)	\$5,449
specify	1GQ400-D1SC	High Output with D-1SC	specify	specify	-	\$4,699
specify	1GQ400-D1SC-I	High Output with Intercooled D-1SC	specify	specify	3 core (825hp)	\$5,899
specify	1GQ400-D1X	High Output with D-1X	specify	specify	-	\$4,899
specify	1GQ400-D1X-I	High Output with Intercooled D-1X	specify	specify	3 core (825hp)	\$5,999
specify	1GQ400-F1D/F1/F1A	High Output with F-1D, F-1, or F-1A	specify	specify	-	\$5,749
specify	1GQ400-F1D-I/F1-I/F1A-I	High Output with Intercooled F-1D, F-1, or F-1A	specify	specify	Sht mtl 3C (950hp)	\$6,999
specify	1GQ400-F1A94/F1C/F1R	High Output with F-1A-94, F-1C or F-1R	specify	specify	-	\$6,099
specify	1GQ400-F1A94-I/F1C-I/F1R-I	High Output with Intercooled F-1A-94, F-1C or F-1R	specify	specify	Sht mtl 3C (1050hp)	\$7,449
specify	1GQ400-F1X	High Output with F-1X	specify	specify	-	\$6,499
specify	1GQ400-F1X-I	High Output with Intercooled F-1X	specify	specify	Sht mtl 3C (1050hp)	\$7,799
specify	1GQ400-F2	High Output with F-2	specify	specify	-	\$6,599
specify	1GQ400-F2-I	High Output with Intercooled F-2	specify	specify	Sht mtl 3C (1050hp)	\$7,899

LT1/LT4 ENGINE SWAP SERPENTINE KITS (2014+)

Year	Part Number	Description	Boost Options	HP Gain	Intercooler	Price
specify	1LT100-P1SC1	High Output with P-1SC-1	specify	specify	-	\$4,299
specify	1LT100-P1SC-I	High Output with Intercooled P-1SC-1	specify	specify	2 core (550hp)	\$5,149
specify	1LT100-D1SC	High Output with D-1SC	specify	specify	-	\$4,549
specify	1LT100-D1SC-I	High Output with Intercooled D-1SC	specify	specify	3 core (825hp)	\$5,749
specify	1LT100-F1D/F1/F1A	High Output with F-1D, F-1, or F-1A	specify	specify	-	\$5,549
specify	1LT100-F1D-I/F1-I/F1A-I	High Output with Intercooled F-1D, F-1, or F-1A	specify	specify	Sht mtl 3C (950hp)	\$6,799
specify	1LT100-F1A94/F1C/F1R	High Output with F-1A-94, F-1C or F-1R	specify	specify	-	\$5,899
specify	1LT100-F1A94-I/F1C-I/F1R-I	High Output with Intercooled F-1A-94, F-1C or F-1R	specify	specify	Sht mtl 3C (1050hp)	\$7,249
specify	1LT100-F1X	High Output with F-1X	specify	specify	-	\$6,299
specify	1LT100-F1X-I	High Output with Intercooled F-1X	specify	specify	Sht mtl 3C (1050hp)	\$7,599
specify	1LT100-F2	High Output with F-2	specify	specify	-	\$6,399
specify	1LT100-F2-I	High Output with Intercooled F-2	specify	specify	Sht mtl 3C (1050hp)	\$7,699

LSx PASS SIDE / LT1 / LT4 SERPENTINE ENGINE SWAP KIT OPTIONS	add "-B" or "-P" to part #	Black or Polished finish for ProCharger (P-series or D-series)	satin standard	-	-	+\$295
	add "-B" or "-P" to part #	Black or Polished finish for ProCharger (F-series, 9" or 9.75" housing)	satin standard	-	-	+\$325
	add "-B" or "-P" to part #	Black or Polished finish for ProCharger (F-series, 10.5" housing)	satin standard	-	-	+\$375
	add "-BB" or "-PB" to part #	Black or Polished finish for main bracket and tensioner	satin standard	-	-	+\$250
	add "-BPB" or "-PPB"	Black or Polished finish for power steering bracket	satin standard	-	-	+\$159
	add "-10R" to part #	10 rib drive system upgrade (LSx Only)	from 8 rib	specify	-	+\$325
	add "-H" to part #	Helical gerset for noise reduction (P-1SC-1, P-1X, D-1SC, D-1X)	same	same	-	+\$100
	A1003A-001	3 core intercooler (825 hp)	from non-ic kit	3" in/outlet	-	+\$975
	A1003A-002	Sheet metal 3 core race intercooler (950 hp)	from non-ic kit	3" in/outlet	-	+\$1,170
	A1003A-005	Sheet metal 3 core race intercooler (1050 hp)	from non-ic kit	3.5" in/outlet	-	+\$1,350
A1045A-001	Sheet metal 3 core race intercooler (1300 hp)	from non-ic kit	3.5" in/outlet	-	+\$1,586	
A1006A-001	Sheet metal 3 core race intercooler (1550 hp)	from non-ic kit	4" in/outlet	-	+\$2,075	
	add "-RV"	Race Bypass Valve, Open or Cosed (specify alum. or steel flange - Red or Black)	from ProFlow	-	-	\$295
LSx ONLY	3GKMM-004	Crank Pin Kit	-	-	-	+\$99
LT1/LT4 ONLY	add "-ATIPP" to part #	ATI Performance Products Balancer Upgrade (ATIPP #917314) - LT1 Only	-	-	-	+\$475
	3LTPS-001	Power steering bracket (requires GM Type II pump) - LT1 only	-	-	-	+\$229
	add "-INT" to part #	Sheet Metal Alum Intake Manifold/Cover (replaces OEM manifold)	unfinished std	-	-	+\$2,189
	add "-INT/INJ" to part #	Sheet Metal Alum Intake Manifold/Cover w/ injector bungs, fuel rails	unfinished std	-	-	+\$2,689
	add "-BI" to part #	Black Finish for Sheet Metal Intake Manifold	unfinished std	-	-	+\$200
	add "-BC" to part #	Black Finish for Sheet Metal Intake Manifold Cover	unfinished std	-	-	+\$30

SPECIFICATIONS (LSx/LT1/LT4 ENGINE SWAP)

PASSENGER SIDE LSx REVERSE ENGINE SWAP KIT

Year	Part Number	Stock HP	HP Gain	Tube Diam	Carb Hat	Drive System	Bypass Valve	Power Steering Bracket (optional)	SC Warranty (in months)	Tubing Supplied	Foot Notes
specify	1GQ400-P1SC1	N/A	specify	-	optional	8 rib	ProFlow	yes	12	-	U5, U7, U8, U9, U10, U11
specify	1GQ400-P1SC1-I	N/A	specify	3"	optional	8 rib	ProFlow	yes	12	yes	U5, U7, U8, U9, U10, U11
specify	1GQ400-P1X	N/A	specify	-	optional	8 rib	ProFlow	yes	12	-	U5, U7, U8, U9, U10, U11
specify	1GQ400-P1X-I	N/A	specify	3"	optional	8 rib	ProFlow	yes	12	yes	U5, U7, U8, U9, U10, U11
specify	1GQ400-D1SC	N/A	specify	-	optional	8 rib	ProFlow	yes	12	-	U5, U7, U8, U9, U10, U11
specify	1GQ400-D1SC-I	N/A	specify	3"	optional	8 rib	ProFlow	yes	12	yes	U5, U7, U8, U9, U10, U11
specify	1GQ400-D1X	N/A	specify	-	optional	8 rib	ProFlow	yes	12	-	U5, U7, U8, U9, U10, U11
specify	1GQ400-D1X-I	N/A	specify	3"	optional	8 rib	ProFlow	yes	12	yes	U5, U7, U8, U9, U10, U11
specify	1GQ400-F1D/F1/F1A	N/A	specify	-	optional	8 rib	Race Valve	yes	12	-	U5, U7, U8, U9, U10, U11
specify	1GQ400-F1D-I/F1-I/F1A-I	N/A	specify	3"	optional	8 rib	Race Valve	yes	12	yes	U5, U7, U8, U9, U10, U11
specify	1GQ400-F1A94/F1C/F1R	N/A	specify	-	optional	8 rib	Race Valve	yes	12	-	U5, U7, U8, U9, U10, U11
specify	1GQ400-F1A94-I/F1C-I/F1R-I	N/A	specify	3.5"	optional	8 rib	Race Valve	yes	12	yes	U5, U7, U8, U9, U10, U11
specify	1GQ100-F1X	N/A	specify	-	optional	8 rib	Race Valve	yes	12	-	U5, U7, U8, U9, U10, U11
specify	1GQ100-F1X-I	N/A	specify	3.5"	optional	8 rib	Race Valve	yes	12	yes	U5, U7, U8, U9, U10, U11
specify	1GQ100-F2	N/A	specify	-	optional	8 rib	Race Valve	yes	12	-	U5, U7, U8, U9, U10, U11
specify	1GQ100-F2-I	N/A	specify	3.5"	optional	8 rib	Race Valve	yes	12	yes	U5, U7, U8, U9, U10, U11

LT1/LT4 ENGINE SWAP SERPENTINE (2014+) SPECIFICATIONS

Year	Part Number	Stock HP	HP Gain	Tube Diam	Carb Hat	Drive System	Bypass Valve	Power Steering Bracket (optional)	SC Warranty (in months)	Tubing Supplied	Foot Notes
specify	1LT100-P1SC-1	N/A	specify	-	optional	8 rib	ProFlow	yes	12	-	U1, U2, U3, U4, U5, U6, U7
specify	1LT100-P1SC1-I	N/A	specify	3"	optional	8 rib	ProFlow	yes	12	yes	U1, U2, U3, U4, U5, U6, U7
specify	1LT100-P1X	N/A	specify	-	optional	8 rib	ProFlow	yes	12	-	U1, U2, U3, U4, U5, U6, U7
specify	1LT100-P1X-I	N/A	specify	3"	optional	8 rib	ProFlow	yes	12	yes	U1, U2, U3, U4, U5, U6, U7
specify	1LT100-D1SC	N/A	specify	-	optional	8 rib	ProFlow	yes	12	-	U1, U2, U3, U4, U5, U6, U7
specify	1LT100-D1SC-I	N/A	specify	3"	optional	8 rib	ProFlow	yes	12	yes	U1, U2, U3, U4, U5, U6, U7
specify	1LT100-D1X	N/A	specify	-	optional	8 rib	ProFlow	yes	12	-	U1, U2, U3, U4, U5, U6, U7
specify	1LT100-D1X-I	N/A	specify	3"	optional	8 rib	ProFlow	yes	12	yes	U1, U2, U3, U4, U5, U6, U7
specify	1LT100-F1D/F1/F1A	N/A	specify	-	optional	8 rib	Race Valve	yes	12	-	U1, U2, U3, U4, U5, U6, U7
specify	1LT100-F1D-I/F1-I/F1A-I	N/A	specify	3"	optional	8 rib	Race Valve	yes	12	yes	U1, U2, U3, U4, U5, U6, U7
specify	1LT100-F1A94/F1C/F1R	N/A	specify	-	optional	8 rib	Race Valve	yes	12	-	U1, U2, U3, U4, U5, U6, U7
specify	1LT100-F1A94-I/F1C-I/F1R-I	N/A	specify	3.5"	optional	8 rib	Race Valve	yes	12	yes	U1, U2, U3, U4, U5, U6, U7
specify	1LT100-F1X	N/A	specify	-	optional	8 rib	Race Valve	yes	12	-	U1, U2, U3, U4, U5, U6, U7
specify	1LT100-F1X-I	N/A	specify	3.5"	optional	8 rib	Race Valve	yes	12	yes	U1, U2, U3, U4, U5, U6, U7
specify	1LT100-F2	N/A	specify	-	optional	8 rib	Race Valve	yes	12	-	U1, U2, U3, U4, U5, U6, U7
specify	1LT100-F2-I	N/A	specify	3.5"	optional	8 rib	Race Valve	yes	12	yes	U1, U2, U3, U4, U5, U6, U7

PASSENGER SIDE LSx/LT1/LT4 ENGINE SWAP FOOTNOTES (specific to above applications):

- | | |
|--|--|
| U1) Comes with ProCharger 8-rib crank pulley, but is also compatible with ATI PP Super Damper (Part# 917314) | U8) 8-rib drive system requires ATI PP balancer #917345 (LSx, wet sump) or #918620 (LS7 dry sump) (not supplied), or Innovator's West balancer #843 (LSx, wet sump) or #853 (LS7 dry sump) (not included - specify hardened hub) |
| U2) Works with OEM LT1 intake and ProCharger LT1/LT4 Sheet Metal Aluminum Intake Manifold | U9) Optional 10-rib requires ATI PP balancer #917347X (LSx, wet sump) (not supplied), or Innovator's West balancer #844 (LSx, wet sump) or #854 (LS7 dry sump) (not included - specify hardened hub) |
| U3) Uses all factory LT1 (Corvette) accessories | U10) May require water pump modification (optional water pump available from ProCharger) |
| U4) Factory power steering pump can be used with an attached fluid reservoir, remote reservoir recommended | U11) LSx passenger side uses common C6 Corvette accessories |
| U5) Compatible with factory and most aftermarket A/C compressors | |
| U6) Specify LT1 or LT4 engine model | |
| U7) Specify wet or dry oil sump | |



CONTACT US AT (913) 338-2886 OR LEARN MORE AT PROCHARGER.COM

2011-21 DODGE CHALLENGER HEMI (6.4) SYSTEMS AND KITS

Year	Part Number	Description	Boost Options	HP Gain	Intercooler	Price
2015-21	1DG515-SCI	High Output Intercooled System with P-1SC-1	7 psi	200+/215+*	3 Core	\$7,449
2015-21	1DG505-SCI	High Output Intercooled Tuner Kit with P-1SC-1	specify	specify	3 Core	\$6,349
2015-21	1DG415-SCI	Stage II Intercooled System with P-1SC-1	7 psi	200+/215+*	3 Core	\$8,349
2015-21	1DG405-SCI	Stage II Intercooled Tuner Kit with P-1SC-1	specify	specify	3 Core	\$7,249
2011-14	1DG314-SCI	High Output Intercooled System with P-1SC-1	7 psi	200+	3 Core	\$7,449
2011-14	1DG304-SCI	High Output Intercooled Tuner Kit with P-1SC-1	specify	specify	3 Core	\$6,349
2011-14	1DG214-SCI	Stage II Intercooled System with P-1SC-1	7 psi	200+	3 Core	\$8,349
2011-14	1DG204-SCI	Stage II Intercooled Tuner Kit with P-1SC-1	specify	specify	3 Core	\$7,249

2011-21 DODGE CHALLENGER HEMI (5.7) SYSTEMS AND KITS

Year	Part Number	Description	Boost Options	HP Gain	Intercooler	Price
2015-21	1DF615-SCI	High Output Intercooled System with P-1SC-1	7 psi	160+	3 Core	\$7,449
2015-21	1DF605-SCI	High Output Intercooled Tuner Kit with P-1SC-1	specify	specify	3 Core	\$6,349
2011-14	1DF414-SCI	High Output Intercooled System with P-1SC-1	7 psi	160+	3 Core	\$7,149
2011-14	1DF404-SCI	High Output Intercooled Tuner Kit with P-1SC-1	specify	specify	3 Core	\$6,349

2011-21 CHALLENGER (6.4, 5.7) OPTIONS	add "-B" or "-P" to part #	Black or Polished finish for ProCharger (P-series or D-series)	satın standard	-	-	+\$295
	add "-B" or "-P" to part #	Black or Polished finish for ProCharger (F-series, 9" housing)	satın standard	-	-	+\$325
	add "-BB" or "-PB" to part #	Black or Polished finish for supercharger bracket	satın standard	-	-	+\$250
	add "-BI" to part #	Black finish for Intercooler (Race Intercooler Only)	satın standard	-	-	+\$150
	add "-H" to part #	Helical gearset for noise reduction (P-1SC-1, P-1X, D-1SC, D-1X)	same	same	-	+\$100
	add "-P1X" to part #	With P-1X ProCharger (replacing P-1SC-1, Systems and Tuner Kits)	same	add'l 10-15+ hp	-	+\$200
	add "-D1SC" to part #	With D-1SC ProCharger (replacing P-1SC-1)	tuner kit only	specify	-	+\$250
	add "-D1X" to part #	With D-1X ProCharger (replacing P-1SC-1, Tuner Kits only)	tuner kit only	specify	-	+\$425
	add "-D" or "-1" or "-A"	With F-1D, F-1, F-1A ProCharger (replacing P-1SC-1)	tuner kit only	specify	-	+\$775
	add "-94" to part #	With F-1A-94 ProCharger (replacing P-1SC-1)	tuner kit only	specify	-	\$1,100
	add "-RVR" or "RVB"	Race Bypass Valve Upgrade (specify open or closed valve)	red or black	specify	-	+\$295
	add "-Race" to part #	Air-to-Air Race intercooler upgrade	from 3 core	1000 hp max	-	+\$345
add "-ATIPP" to part #	ATI Balancer Upgrade (6.4 Stage II Systems and Tuner Kits only)	-	-	-	+\$475	
add "-MS" to part #	MAP sensor adaptor bag	tuner kit only	same	-	+\$199	
add "-FP" to part #	In-Tank Fuel Pump	tuner kit only	same	-	+\$436	

2015-20 DODGE CHALLENGER V6 (3.6) SYSTEMS AND KITS

Year	Part Number	Description	Boost Options	HP Gain	Intercooler	Price
2015-20	1DQ214-SCI	High Output Intercooled System with P-1SC-1	7 psi	40-45%+	3 Core	\$6,899
2015-20	1DQ204-SCI	High Output Intercooled Tuner Kit with P-1SC-1	specify	specify	3 Core	\$5,899

2015-20 CHALLENGER (3.6) OPTIONS	add "-B" or "-P" to part #	Black or Polished finish for ProCharger (P-series or D-series)	satın standard	-	-	+\$295
	add "-B" or "-P" to part #	Black or Polished finish for ProCharger (F-series, 9" housing)	satın standard	-	-	+\$325
	add "-BB" or "-PB" to part #	Black or Polished finish for supercharger bracket	satın standard	-	-	+\$250
	add "-BI" to part #	Black finish for Intercooler (Race Intercooler Only)	satın standard	-	-	+\$150
	add "-H" to part #	Helical gearset for noise reduction (P-1SC-1, P-1X, D-1SC, D-1X)	same	same	-	+\$100
	add "-P1X" to part #	With P-1X ProCharger (replacing P-1SC-1, Systems and Tuner Kits)	same	add'l 10-15+ hp	-	+\$200
	add "-D1SC" to part #	With D-1SC ProCharger (replacing P-1SC-1)	tuner kit only	specify	-	+\$250
	add "-D1X" to part #	With D-1X ProCharger (replacing P-1SC-1, Tuner Kits only)	tuner kit only	specify	-	+\$425
	add "-RVR" or "RVB"	Race Bypass Valve Upgrade (specify open or closed valve)	red or black	specify	-	+\$295
	add "-MS" to part #	MAP sensor adaptor bag	tuner kit only	same	-	+\$199

2011-14 DODGE CHALLENGER V6 (3.6) SYSTEMS AND KITS COMING SOON

SPECIFICATIONS (2011-21 CHALLENGER)

2011-21 DODGE CHALLENGER HEMI (6.4) SPECIFICATIONS

Year	Part Number	OEM HP Rating	HP Gain	Tube Diam	IC Mount	Drive System	Bypass System	Fuel System Upgrade	Fuel Inj. Supplied	Computer/Ignition Modifications	SC Warranty (in months)	CARB E.O.	Foot Notes
2015-21	1DG515-SCI	485	200+/215+*	3"	V	stk 6 rib	ProFlow	MAP sensor, in-tank pump	52 lbs/hr	programmer supplied	12, 36 opt. (\$99)	D-365-26 (15-20)	V1, V2, V3, V4, V5, V7, V8, V9
2015-21	1DG505-SCI	485	specify	3"	V	stk 6 rib	ProFlow	not supplied	No	not supplied	12	-	V1, V2, V3, V4, V5, V7, V8, V9
2015-21	1DG415-SCI	485	200+/215+*	3"	V	add'l 8 rib	ProFlow	MAP sensor, in-tank pump	52 lbs/hr	programmer supplied	12, 36 opt. (\$99)	D-365-26 (15-20)	V1, V2, V3, V4, V5, V6, V7, V8, V9
2015-21	1DG405-SCI	485	specify	3"	V	add'l 8 rib	ProFlow	not supplied	No	not supplied	12	-	V1, V3, V4, V5, V6, V7, V8, V9
2011-14	1DG314-SCI	470	200+	3"	V	stk 6 rib	ProFlow	MAP sensor, in-tank pump	52 lbs/hr	programmer supplied	12, 36 opt. (\$99)	D-365-22	V1, V2, V3, V4, V5, V9
2011-14	1DG304-SCI	470	specify	3"	V	stk 6 rib	ProFlow	not supplied	No	not supplied	12	-	V1, V3, V4, V5, V9
2011-14	1DG214-SCI	470	200+	3"	V	add'l 8 rib	ProFlow	MAP sensor, in-tank pump	52 lbs/hr	programmer supplied	12, 36 opt. (\$99)	D-365-22	V1, V2, V3, V4, V5, V6, V9
2011-14	1DG204-SCI	470	specify	3"	V	add'l 8 rib	ProFlow	not supplied	No	not supplied	12	-	V1, V3, V4, V5, V6, V9

2011-21 DODGE CHALLENGER HEMI (5.7) SPECIFICATIONS

Year	Part Number	OEM HP Rating	HP Gain	Tube Diam	IC Mount	Drive System	Bypass System	Fuel System Upgrade	Fuel Inj. Supplied	Computer/Ignition Modifications	SC Warranty (in months)	CARB E.O.	Foot Notes
2015-21	1DF615-SCI	375	160+	3"	V	stk 6 rib	ProFlow	MAP sensor, in-tank pump	39.5 lbs/hr	programmer supplied	12, 36 opt. (\$99)	D-365-26 (15-20)	V1, V2, V3, V4, V5, V7, V8, V9, V10
2015-21	1DF605-SCI	375	specify	3"	V	stk 6 rib	ProFlow	not supplied	No	not supplied	12	-	V1, V3, V4, V5, V7, V9, V10
2011-14	1DF414-SCI	375	160+	3"	V	stk 6 rib	ProFlow	MAP sensor	39.5 lbs/hr	programmer supplied	12, 36 opt. (\$99)	D-365-22	V1, V2, V3, V4, V5, V9, V10
2011-14	1DF404-SCI	375	specify	3"	V	stk 6 rib	ProFlow	not supplied	No	not supplied	12	-	V1, V3, V4, V5, V9, V10

* 215+ hp with HO Intercooled System and Race intercooler upgrade

2015-20 DODGE CHALLENGER V6 (3.6) SPECIFICATIONS

Year	Part Number	OEM HP Rating	HP Gain	Tube Diam	IC Mount	Drive System	Bypass System	Fuel System Upgrade	Fuel Inj. Supplied	Computer/Ignition Modifications	SC Warranty (in months)	CARB E.O.	Foot Notes
2015-20	1DQ214-SCI	305	40-45%+	3"	V	add'l 6 rib	ProFlow	MAP sensor	50 lb/hr	programmer supplied	12, 36 opt. (\$99)	-	V1, V2, V4, V5, V8, V10
2015-20	1DQ204-SCI	305	specify	3"	V	add'l 6 rib	ProFlow	not supplied	No	not supplied	12	-	V1, V4, V5, V8, V10

DODGE AUTOMOTIVE FOOTNOTES (specific to above applications):

- V1) Model year must be specified
- V2) Due to variability among OEM computers, and the prevalence of custom modifications, dyno tuning may be required
- V3) Specify engine size (5.7 or 6.4)
- V4) Specify manual or automatic transmission
- V5) Systems ship in extra large box
- V6) Purchase of aftermarket balancer required, ATI PP part #918459 (not included - specify hardened hub)
- V7) Specify Shaker or standard hood
- V8) 2015+ vehicles may require ECM unlock (call for details)
- V9) Specify with or without strut bar
- V10) 2WD models only; AWD models must use Tuner Kit and may require modifications



2008-10 DODGE CHALLENGER HEMI SRT8 (6.1) SYSTEMS AND KITS

Year	Part Number	Description	Boost Options	HP Gain	Intercooler	Price
2008-10	1DF314-SCI-6.1	High Output Intercooled System with P-1SC-1	7 psi	160+	3 Core	\$7,099
2008-10	1DF304-SCI-6.1	High Output Intercooled Tuner Kit with P-1SC-1	specify	specify	3 Core	\$5,999
2008-10	1DF214-SCI-6.1	Stage II Intercooled System with P-1SC-1	7 psi	160+	3 Core	\$8,049
2008-10	1DF204-SCI-6.1	Stage II Intercooled Tuner Kit with P-1SC-1	specify	specify	3 Core	\$6,949

2008-10 CHALLENGER (6.1) OPTIONS	add "-B" or "-P" to part #	Black or Polished finish for ProCharger (P-series or D-series)	satin standard	-	-	+\$295
	add "-B" or "-P" to part #	Black or Polished finish for ProCharger (F-series, 9" housing)	satin standard	-	-	+\$325
	add "-BB" to part #	Black finish for supercharger bracket (HO only)	satin standard	-	-	+\$250
	add "-PHO" to part #	Polished finish for HO supercharger bracket	satin standard	-	-	+\$250
	add "-PST" to part #	Polished finish for Stage II supercharger bracket	satin standard	-	-	+\$300
	add "-H" to part #	Helical gearset for noise reduction (P-1SC-1, P-1X, D-1SC, D-1X)	same	same	-	+\$100
	add "-P1X" to part #	With P-1X ProCharger (replacing P-1SC-1, Systems and Tuner Kits)	same	add'l 10-15+ hp	-	+\$200
	add "-D1SC" to part #	With D-1SC ProCharger (replacing P-1SC-1)	tuner kit only	specify	-	+\$250
	add "-D1X" to part #	With D-1X ProCharger (replacing P-1SC-1, Tuner Kits only)	tuner kit only	specify	-	+\$425
	add "-D" or "-1" or "-A"	With F-1D, F-1, F-1A ProCharger (replacing P-1SC-1, Stage II only)	tuner kit only	specify	-	+\$775
	add "-RVR" or "RVB"	Race Bypass Valve Upgrade (specify open or closed valve)	red or black	specify	-	+\$295
	add "-BU" to part #	Stage II belt upgrade (time of purchase, required for F-series models)	-	-	-	+\$75
add "-MS" to part #	MAP sensor adaptor bag	tuner kit only	same	-	+\$199	
add "-FP" to part #	In-Tank Fuel Pump	tuner kit only	same	-	+\$436	

2008-10 DODGE CHALLENGER HEMI R/T (5.7) SYSTEMS AND KITS

Year	Part Number	Description	Boost Options	HP Gain	Intercooler	Price
2008-10	1DF314-SCI-5.7	High Output Intercooled System with P-1SC-1	7 psi	130+	3 Core	\$6,849
2008-10	1DF304-SCI-5.7	High Output Intercooled Tuner Kit with P-1SC-1	specify	specify	3 Core	\$5,999

2008-10 CHALLENGER (5.7) OPTIONS	add "-B" or "-P" to part #	Black or Polished finish for ProCharger (P-series or D-series)	satin standard	-	-	+\$295
	add "-B" or "-P" to part #	Black or Polished finish for ProCharger (F-series, 9" housing)	satin standard	-	-	+\$325
	add "-BB" to part #	Black finish for supercharger bracket (HO only)	satin standard	-	-	+\$250
	add "-PHO" to part #	Polished finish for HO supercharger bracket	satin standard	-	-	+\$250
	add "-PST" to part #	Polished finish for Stage II supercharger bracket	satin standard	-	-	+\$300
	add "-H" to part #	Helical gearset for noise reduction (P-1SC-1, P-1X, D-1SC, D-1X)	same	same	-	+\$100
	add "-P1X" to part #	With P-1X ProCharger (replacing P-1SC-1, Systems and Tuner Kits)	same	add'l 10-15+ hp	-	+\$200
	add "-D1SC" to part #	With D-1SC ProCharger (replacing P-1SC-1)	tuner kit only	specify	-	+\$250
	add "-D1X" to part #	With D-1X ProCharger (replacing P-1SC-1, Tuner Kits only)	tuner kit only	specify	-	+\$425
	add "-D" or "-1" or "-A"	With F-1D, F-1, F-1A ProCharger (replacing P-1SC-1)	tuner kit only	specify	-	+\$775
	add "-RVR" or "RVB"	Race Bypass Valve Upgrade (specify open or closed valve)	red or black	specify	-	+\$295

FOR HEMI REVERSE COG RACE KITS (6.1/5.7) SEE PAGE 58

SPECIFICATIONS (2008-10 CHALLENGER)

2008-10 DODGE CHALLENGER HEMI SRT8 (6.1) SPECIFICATIONS

Year	Part Number	OEM HP Rating	HP Gain	Tube Diam	IC Mount	Drive System	Bypass System	Fuel System Upgrade	Fuel Inj. Supplied	Computer/Ignition Modifications	SC Warranty (in months)	CARB E.O.	Foot Notes
2008-10	1DF314-SCI	425	160+	3"	V	stk 6 rib	ProFlow	MAP sensor, in-tank pump	39.5 lbs/hr	programmer supplied	12, 36 opt. (\$99)	D-365-7	W1, W3, W4, W5
2008-10	1DF304-SCI	425	specify	3"	V	stk 6 rib	ProFlow	not supplied	No	not supplied	12	-	W1, W3, W4, W5
2008-10	1DF214-SCI	425	160+	3"	V	add'l 8 rib	ProFlow	MAP sensor, in-tank pump	39.5 lbs/hr	programmer supplied	12, 36 opt. (\$99)	-	W1, W2, W3, W4, W5, W6, W7
2008-10	1DF204-SCI	425	specify	3"	V	add'l 8 rib	ProFlow	not supplied	No	not supplied	12	-	W1, W3, W4, W5, W6, W7

2008-10 DODGE CHALLENGER HEMI R/T (5.7) SPECIFICATIONS

Year	Part Number	OEM HP Rating	HP Gain	Tube Diam	IC Mount	Drive System	Bypass System	Fuel System Upgrade	Fuel Inj. Supplied	Computer/Ignition Modifications	SC Warranty (in months)	CARB E.O.	Foot Notes
2008-10	1DF314-SCI	370	130+	3"	V	stk 6 rib	ProFlow	MAP sensor	39.5 lbs/hr	programmer supplied	12, 36 opt. (\$99)	D-365-7 (09-10)	W1, W3, W4, W5
2008-10	1DF304-SCI	370	specify	3"	V	stk 6 rib	ProFlow	not supplied	No	not supplied	12	-	W1, W3, W4, W5

DODGE AUTOMOTIVE FOOTNOTES (specific to above applications):

- W1) Model year must be specified
- W2) Due to variability among OEM computers, and the prevalence of custom modifications, dyno tuning may be required
- W3) Specify engine size (5.7 or 6.1)
- W4) Specify manual or automatic transmission
- W5) Systems ship in extra large box
- W6) Purchase of aftermarket balancer required (not included - specify hardened hub):
5.7 (2008) = ATI PP part #918435
5.7 (2009-10) = ATI PP part #918445
6.1 = ATI PP part #918432
- W7) Special order kit: order form and non-refundable deposit required at time of order—may require additional lead time for processing

2012-21 DODGE CHARGER HEMI (6.4) SYSTEMS AND KITS

Year	Part Number	Description	Boost Options	HP Gain	Intercooler	Price
2015-21	1DI515-SCI	High Output Intercooled System with P-1SC-1	7 psi	200+/215+*	3 Core	\$7,449
2015-21	1DI505-SCI	High Output Intercooled Tuner Kit with P-1SC-1	specify	specify	3 Core	\$6,349
2015-21	1DI415-SCI	Stage II Intercooled System with P-1SC-1	7 psi	200+/215+*	3 Core	\$8,349
2015-21	1DI405-SCI	Stage II Intercooled Tuner Kit with P-1SC-1	specify	specify	3 Core	\$7,249
2012-14	1DI314-SCI	High Output Intercooled System with P-1SC-1	7 psi	200+	3 Core	\$7,449
2012-14	1DI304-SCI	High Output Intercooled Tuner Kit with P-1SC-1	specify	specify	3 Core	\$6,349

2012-21 CHARGER (6.4) OPTIONS	add "-B" or "-P" to part #	Black or Polished finish for ProCharger (P-series or D-series)	satin standard	-	-	+\$295
	add "-B" or "-P" to part #	Black or Polished finish for ProCharger (F-series, 9" housing)	satin standard	-	-	+\$325
	add "-BB" or "-PB" to part #	Black or Polished finish for supercharger bracket	satin standard	-	-	+\$250
	add "-BI" to part #	Black finish for Intercooler (Race Intercooler Only)	satin standard	-	-	+\$150
	add "-H" to part #	Helical gearset for noise reduction (P-1SC-1, P-1X, D-1SC, D-1X)	same	same	-	+\$100
	add "-P1X" to part #	With P-1X ProCharger (replacing P-1SC-1, Systems and Tuner Kits)	same	add'l 10-15+ hp	-	+\$200
	add "-D1SC" to part #	With D-1SC ProCharger (replacing P-1SC-1)	tuner kit only	specify	-	+\$250
	add "-D1X" to part #	With D-1X ProCharger (replacing P-1SC-1, Tuner Kits only)	tuner kit only	specify	-	+\$425
	add "-D" or "-1" or "-A"	With F-1D, F-1, F-1A ProCharger (replacing P-1SC-1)	tuner kit only	specify	-	+\$775
	add "-94" to part #	With F-1A-94 ProCharger (replacing P-1SC-1)	tuner kit only	specify	-	+\$1,100
	add "-RVR" or "-RVB"	Race Bypass Valve Upgrade (specify open or closed valve)	red or black	specify	-	+\$295
	add "-Race" to part #	Air-to-Air Race intercooler upgrade	from 3 core	1000 hp max	-	+\$345
add "-ATIPP" to part #	ATI Balancer Upgrade (6.4 Stage II Systems and Tuner Kits only)	-	-	-	+\$475	
add "-MS" to part #	MAP sensor adaptor bag	tuner kit only	same	-	+\$199	
add "-FP" to part #	In-Tank Fuel Pump	tuner kit only	same	-	+\$436	

2011-21 DODGE CHARGER HEMI (5.7) SYSTEMS AND KITS

Year	Part Number	Description	Boost Options	HP Gain	Intercooler	Price
2015-21	1DI615-SCI	High Output Intercooled System with P-1SC-1	7 psi	160+	3 Core	\$7,449
2015-21	1DI605-SCI	High Output Intercooled Tuner Kit with P-1SC-1	specify	specify	3 Core	\$6,349
2011-14	1DI414-SCI	High Output Intercooled System with P-1SC-1	7 psi	160+	3 Core	\$7,149
2011-14	1DI404-SCI	High Output Intercooled Tuner Kit with P-1SC-1	specify	specify	3 Core	\$6,349

2011-21 CHARGER (5.7) OPTIONS	add "-B" or "-P" to part #	Black or Polished finish for ProCharger (P-series or D-series)	satin standard	-	-	+\$295
	add "-B" or "-P" to part #	Black or Polished finish for ProCharger (F-series, 9" housing)	satin standard	-	-	+\$325
	add "-BB" or "-PB" to part #	Black or Polished finish for supercharger bracket	satin standard	-	-	+\$250
	add "-BI" to part #	Black finish for Intercooler (Race Intercooler Only)	satin standard	-	-	+\$150
	add "-H" to part #	Helical gearset for noise reduction (P-1SC-1, P-1X, D-1SC, D-1X)	same	same	-	+\$100
	add "-P1X" to part #	With P-1X ProCharger (replacing P-1SC-1, Systems and Tuner Kits)	same	add'l 10-15+ hp	-	+\$200
	add "-D1SC" to part #	With D-1SC ProCharger (replacing P-1SC-1)	tuner kit only	specify	-	+\$250
	add "-D1X" to part #	With D-1X ProCharger (replacing P-1SC-1, Tuner Kits only)	tuner kit only	specify	-	+\$425
	add "-D" or "-1" or "-A"	With F-1D, F-1, F-1A ProCharger (replacing P-1SC-1)	tuner kit only	specify	-	+\$775
	add "-94" to part #	With F-1A-94 ProCharger (replacing P-1SC-1)	tuner kit only	specify	-	+\$1,100
	add "-RVR" or "-RVB"	Race Bypass Valve Upgrade (specify open or closed valve)	red or black	specify	-	+\$295
	add "-Race" to part #	Air-to-Air Race intercooler upgrade	from 3 core	1000 hp max	-	+\$345
add "-MS" to part #	MAP sensor adaptor bag	tuner kit only	same	-	+\$199	
add "-FP" to part #	In-Tank Fuel Pump	tuner kit only	same	-	+\$436	

2011-20 DODGE CHARGER V6 (3.6) SYSTEMS AND KITS – COMING SOON

SPECIFICATIONS (2011-21 CHARGER)

2012-21 DODGE CHARGER HEMI SRT8 (6.4) SPECIFICATIONS

Year	Part Number	OEM HP Rating	HP Gain	Tube Diam	Intercooler Mount	Drive System	Bypass System	Fuel System Upgrade	Fuel Inj. Supplied	Computer/Ignition Modifications	SC Warranty (in months)	CARB E.O.	Foot Notes
2015-21	1DI515-SCI	485	200+/215+*	3"	V	stk 6 rib	ProFlow	MAP sensor, in-tank pump	52 lbs/hr	programmer supplied	12, 36 opt. (\$99)	D-365-26(15-20)	X1, X3, X4, X5
2015-21	1DI505-SCI	485	specify	3"	V	stk 6 rib	ProFlow	not supplied	No	not supplied	12	-	X1, X3, X4, X5
2015-21	1DI415-SCI	485	200+/215+*	3"	V	add'l 8 rib	ProFlow	MAP sensor, in-tank pump	52 lbs/hr	programmer supplied	12, 36 opt. (\$99)	-	X1, X3, X4, X5, X6
2015-20	1DI405-SCI	485	specify	3"	V	add'l 8 rib	ProFlow	not supplied	No	not supplied	12	-	X1, X3, X4, X6
2012-14	1DI314-SCI	470	200+	3"	V	stk 6 rib	ProFlow	MAP sensor, in-tank pump	52 lbs/hr	programmer supplied	12, 36 opt. (\$99)	D-365-22	X1, X3, X4
2012-14	1DI304-SCI	470	specify	3"	V	stk 6 rib	ProFlow	not supplied	No	not supplied	12	-	X1, X3, X4

2011-21 DODGE CHARGER HEMI R/T (5.7) SPECIFICATIONS

Year	Part Number	OEM HP Rating	HP Gain	Tube Diam	Intercooler Mount	Drive System	Bypass System	Fuel System Upgrade	Fuel Inj. Supplied	Computer/Ignition Modifications	SC Warranty (in months)	CARB E.O.	Foot Notes
2015-21	1DI615-SCI	375	160+	3"	V	stk 6 rib	ProFlow	MAP sensor, in-tank pump	39.5 lbs/hr	programmer supplied	12, 36 opt. (\$99)	D-365-18 (15-19)	X1, X3, X4, X5
2015-21	1DI605-SCI	375	specify	3"	V	stk 6 rib	ProFlow	not supplied	No	not supplied	12	-	X1, X3, X4, X5
2011-14	1DI414-SCI	370	160+	3"	V	stk 6 rib	ProFlow	MAP sensor	39.5 lbs/hr	programmer supplied	12, 36 opt. (\$99)	D-365-22	X1, X3, X4
2011-14	1DI404-SCI	370	specify	3"	V	stk 6 rib	ProFlow	not supplied	No	not supplied	12	-	X1, X3, X4

* 215+ hp with HO Intercooled System and Race intercooler upgrade

DODGE AUTOMOTIVE FOOTNOTES (specific to above applications):

- X1) Model year must be specified
- X2) Due to variability among OEM computers, and the prevalence of custom modifications, dyno tuning may be required
- X3) Systems ship in extra large box
- X4) 2WD models only; AWD models must use Tuner Kit and may require modifications
- X5) 2015+ vehicles may require ECM unlock (call for details)
- X6) Purchase of aftermarket balancer required, ATI PP part #918459 (not included - specify hardened hub)

2006-10 DODGE CHARGER HEMI SRT8 (6.1) SYSTEMS AND KITS

Year	Part Number	Description	Boost Options	HP Gain	Intercooler	Price
2006-10	1DD314-SCI-6.1	High Output Intercooled System with P-1SC-1	7 psi	160+	3 Core	\$7,099
2006-10	1DD304-SCI-6.1	High Output Intercooled Tuner Kit with P-1SC-1	specify	specify	3 Core	\$5,999
2006-10	1DD214-SCI-6.1	Stage II Intercooled System with P-1SC-1	7 psi	160+	3 Core	\$8,049
2006-10	1DD204-SCI-6.1	Stage II Intercooled Tuner Kit with P-1SC-1	specify	specify	3 Core	\$6,949

2006-10 CHARGER (6.1) OPTIONS	add "-P" to part #	Polished finish for ProCharger (P-series or D-series)	satin standard	-	-	+\$295
	add "-P" to part #	Polished finish for ProCharger (F-series, 9" housing)	satin standard	-	-	+\$325
	add "-PHO" to part #	Polished finish for HO supercharger bracket	satin standard	-	-	+\$250
	add "-PST" to part #	Polished finish for Stage II supercharger bracket	satin standard	-	-	+\$300
	add "-H" to part #	Helical gearset for noise reduction (P-1SC-1, P-1X, D-1SC, D-1X)	same	same	-	+\$100
	add "-P1X" to part #	With P-1X ProCharger (replacing P-1SC-1, Systems and Tuner Kits)	same	add'l 10-15+ hp	-	+\$200
	add "-D1SC" to part #	With D-1SC ProCharger (replacing P-1SC-1)	tuner kit only	specify	-	+\$250
	add "-D1X" to part #	With D-1X ProCharger (replacing P-1SC-1, Tuner Kits only)	tuner kit only	specify	-	+\$425
	add "-D" or "-1" or "-A"	With F-1D, F-1, F-1A ProCharger (replacing P-1SC-1, Stage II only)	tuner kit only	specify	-	+\$775
	add "-RVR" or "RVB"	Race Bypass Valve Upgrade (specify open or closed valve)	red or black	specify	-	+\$295
	add "-BU" to part #	Stage II belt upgrade (time of purchase, required for F-series models)	-	-	-	+\$75
add "-MS" to part #	MAP sensor adaptor bag	tuner kit only	same	-	+\$199	
add "-FP" to part #	In-Tank Fuel Pump	tuner kit only	same	-	+\$436	

2006-10 DODGE CHARGER HEMI R/T (5.7) SYSTEMS AND KITS

Year	Part Number	Description	Boost Options	HP Gain	Intercooler	Price
2006-10	1DD314-SCI-5.7	High Output Intercooled System with P-1SC-1	7 psi	110+/130+*	3 Core	\$6,849
2006-10	1DD304-SCI-5.7	High Output Intercooled Tuner Kit with P-1SC-1	specify	specify	3 Core	\$5,999
2006-08	1DD214-SCI-5.7	Stage II Intercooled System with P-1SC-1	7 psi	110+	3 Core	\$7,799
2006-08	1DD204-SCI-5.7	Stage II Intercooled Tuner Kit with P-1SC-1	specify	specify	3 Core	\$6,949

2006-10 CHARGER (5.7) OPTIONS	add "-P" to part #	Polished finish for ProCharger (P-series or D-series)	satin standard	-	-	+\$295
	add "-P" to part #	Polished finish for ProCharger (F-series, 9" housing)	satin standard	-	-	+\$325
	add "-PHO" to part #	Polished finish for HO supercharger bracket	satin standard	-	-	+\$250
	add "-PST" to part #	Polished finish for Stage II supercharger bracket	satin standard	-	-	+\$300
	add "-H" to part #	Helical gearset for noise reduction (P-1SC-1, P-1X, D-1SC, D-1X)	same	same	-	+\$100
	add "-P1X" to part #	With P-1X ProCharger (replacing P-1SC-1, Systems and Tuner Kits)	same	add'l 10-15+ hp	-	+\$200
	add "-D1SC" to part #	With D-1SC ProCharger (replacing P-1SC-1)	tuner kit only	specify	-	+\$250
	add "-D1X" to part #	With D-1X ProCharger (replacing P-1SC-1, Tuner Kits only)	tuner kit only	specify	-	+\$425
	add "-D" or "-1" or "-A"	With F-1D, F-1, F-1A ProCharger (replacing P-1SC-1, Stage II only)	tuner kit only	specify	-	+\$775
	add "-RVR" or "RVB"	Race Bypass Valve Upgrade (specify open or closed valve)	red or black	specify	-	+\$295
	add "-BU" to part #	Stage II belt upgrade (time of purchase, required for F-series models)	-	-	-	+\$75

FOR HEMI REVERSE COG RACE KITS (6.1/5.7) SEE PAGE 58

SPECIFICATIONS (2006-10 CHARGER)

2006-10 DODGE CHARGER HEMI SRT8 (6.1) SPECIFICATIONS

Year	Part Number	OEM HP Rating	HP Gain	Tube Diam	IC Mount	Drive System	Bypass System	Fuel System Upgrade	Fuel Inj. Supplied	Computer/Ignition Modifications	SC Warranty (in months)	CARB E.O.	Foot Notes
2006-10	1DD314-SCI-6.1	425	160+	3"	V	stk 6 rib	ProFlow	MAP sensor, in-tank pump	39.5 lbs/hr	programmer supplied	12, 36 opt. (\$99)	D-365-7	Y1, Y3, Y4, Y6
2006-10	1DD304-SCI-6.1	425	specify	3"	V	stk 6 rib	ProFlow	not supplied	No	not supplied	12	-	Y1, Y3, Y4, Y6
2006-10	1DD214-SCI-6.1	425	160+	3"	V	add'l 8 rib	ProFlow	MAP sensor, in-tank pump	39.5 lbs/hr	programmer supplied	12, 36 opt. (\$99)	-	Y1, Y2, Y3, Y4, Y5, Y6, Y7
2006-10	1DD204-SCI-6.1	425	specify	3"	V	add'l 8 rib	ProFlow	not supplied	No	not supplied	12	-	Y1, Y3, Y4, Y5, Y6, Y7

2006-10 DODGE CHARGER HEMI R/T (5.7) SPECIFICATIONS

Year	Part Number	OEM HP Rating	HP Gain	Tube Diam	IC Mount	Drive System	Bypass System	Fuel System Upgrade	Fuel Inj. Supplied	Computer/Ignition Modifications	SC Warranty (in months)	CARB E.O.	Foot Notes
2006-10	1DD314-SCI-5.7	340/370	110+/130+*	3"	V	stk 6 rib	ProFlow	MAP sensor	39.5 lbs/hr	programmer supplied	12, 36 opt. (\$99)	D-365-7	Y1, Y3, Y4, Y6
2006-10	1DD304-SCI-5.7	340/370	specify	3"	V	stk 6 rib	ProFlow	not supplied	No	not supplied	12	-	Y1, Y3, Y4, Y6
2006-08	1DD214-SCI-5.7	340	110+	3"	V	add'l 8 rib	ProFlow	MAP sensor	39.5 lbs/hr	programmer supplied	12, 36 opt. (\$99)	-	Y1, Y3, Y4, Y5, Y6, Y7
2006-08	1DD204-SCI-5.7	340	specify	3"	V	add'l 8 rib	ProFlow	not supplied	No	not supplied	12	-	Y1, Y3, Y4, Y5, Y6, Y7

* 130+ hp with 2009-10 5.7L VCT engines

DODGE/AUTOMOTIVE FOOTNOTES (specific to above applications):

- Y1) Model year must be specified
- Y2) Due to variability among OEM computers, and the prevalence of custom modifications, dyno tuning may be required
- Y3) Specify engine size (5.7 or 6.1)
- Y4) Systems ship in extra large box
- Y5) Purchase of aftermarket balancer required (not included - specify hardened hub):
5.7 (2006-08) = ATI PP part #918435
6.1 = ATI PP part #918432
- Y6) 2WD models only; AWD models must use Tuner Kit and may require modifications
- Y7) Special order kit: order form and non-refundable deposit required at time of order—may require additional lead time for processing



2012-14 CHRYSLER 300 HEMI SRT8 (6.4) SYSTEMS AND KITS

Year	Part Number	Description	Boost Options	HP Gain	Intercooler	Price
2012-14	1DK314-SCI	High Output Intercooled System with P-1SC-1	7 psi	200+	3 Core	\$7,449
2012-14	1DK304-SCI	High Output Intercooled Tuner Kit with P-1SC-1	specify	specify	3 Core	\$6,349

2011-20 CHRYSLER 300 HEMI (5.7) SYSTEMS AND KITS

Year	Part Number	Description	Boost Options	HP Gain	Intercooler	Price
2015-20	1DK414-SCI	High Output Intercooled System with P-1SC-1	7 psi	160+	3 Core	\$7,099
2015-20	1DK404-SCI	High Output Intercooled Tuner Kit with P-1SC-1	specify	specify	3 Core	\$6,299
2011-14	1DK414-SCI	High Output Intercooled System with P-1SC-1	7 psi	160+	3 Core	\$7,099
2011-14	1DK404-SCI	High Output Intercooled Tuner Kit with P-1SC-1	specify	specify	3 Core	\$6,299

2011-20 300 (6.4, 5.7) OPTIONS	add "-B" or "-P" to part #	Black or Polished finish for ProCharger (P-series or D-series)	satin standard	-	-	+\$295
	add "-B" or "-P" to part #	Black or Polished finish for ProCharger (F-series, 9" housing)	satin standard	-	-	+\$325
	add "-PHO" to part #	Polished finish for supercharger bracket	satin standard	-	-	+\$250
	add "-BB" to part #	Black finish for supercharger bracket	satin standard	-	-	+\$250
	add "-H" to part #	Helical gearset for noise reduction (P-1SC-1, P-1X, D-1SC, D-1X)	same	same	-	+\$100
	add "-P1X" to part #	With P-1X ProCharger (replacing P-1SC-1, Systems and Tuner Kits)	same	add'l 10-15+ hp	-	+\$200
	add "-D1SC" to part #	With D-1SC ProCharger (replacing P-1SC-1)	tuner kit only	specify	-	+\$250
	add "-D1X" to part #	With D-1X ProCharger (replacing P-1SC-1, Tuner Kits only)	tuner kit only	specify	-	+\$425
add "-D" or "-1" or "-A"	With F-1D, F-1, F-1A ProCharger (replacing P-1SC-1)	tuner kit only	specify	-	+\$775	
add "-RVR" or "RVB"	Race Bypass Valve Upgrade (specify open or closed valve)	red or black	specify	-	+\$295	

2005-10 CHRYSLER 300 HEMI (6.1) SYSTEMS AND KITS

Year	Part Number	Description	Boost Options	HP Gain	Intercooler	Price
2005-10 (6.1)	1DE314-SCI-6.1	High Output Intercooled System with P-1SC-1	7 psi	160+	3 Core	\$7,099
2005-10 (6.1)	1DE304-SCI-6.1	High Output Intercooled Tuner Kit with P-1SC-1	specify	specify	3 Core	\$5,999

2005-10 CHRYSLER 300 HEMI (5.7) SYSTEMS AND KITS

Year	Part Number	Description	Boost Options	HP Gain	Intercooler	Price
2005-10 (5.7)	1DE314-SCI-5.7	High Output Intercooled System with P-1SC-1	7 psi	110+/130+*	3 Core	\$6,849
2005-10 (5.7)	1DE304-SCI-5.7	High Output Intercooled Tuner Kit with P-1SC-1	specify	specify	3 Core	\$5,999

2005-10 300 (6.1, 5.7) OPTIONS	add "-P" to part #	Polished finish for ProCharger (P-series or D-series)	satin standard	-	-	+\$295
	add "-P" to part #	Polished finish for ProCharger (F-series, 9" housing)	satin standard	-	-	+\$325
	add "-PHO" to part #	Polished finish for supercharger bracket	satin standard	-	-	+\$250
	add "-H" to part #	Helical gearset for noise reduction (P-1SC-1, P-1X, D-1SC, D-1X)	same	same	-	+\$100
	add "-P1X" to part #	With P-1X ProCharger (replacing P-1SC-1, Systems and Tuner Kits)	same	add'l 10-15+ hp	-	+\$200
	add "-D1SC" to part #	With D-1SC ProCharger (replacing P-1SC-1)	tuner kit only	specify	-	+\$250
	add "-D1X" to part #	With D-1X ProCharger (replacing P-1SC-1, Tuner Kits only)	tuner kit only	specify	-	+\$425
	add "-D" or "-1" or "-A"	With F-1D, F-1, F-1A ProCharger (replacing P-1SC-1)	tuner kit only	specify	-	+\$775
add "-RVR" or "RVB"	Race Bypass Valve Upgrade (specify open or closed valve)	red or black	specify	-	+\$295	

SPECIFICATIONS (2005-20 300)

2012-14 CHRYSLER 300 HEMI SRT8 (6.4) SPECIFICATIONS

Year	Part Number	OEM HP Rating	HP Gain	Tube Diam	Intercooler Mount	Drive System	Bypass System	Fuel System Upgrade	Fuel Inj. Supplied	Computer/Ignition Modifications	SC Warranty (in months)	CARB E.O.	Foot Notes
2012-14	1DK314-SCI	470	200+	3"	V	stk 6 rib	ProFlow	MAP sensor, in-tank pump	52 lbs/hr	programmer sup.	12, 36 opt. (\$99)	D-365-22	Z1, Z2, Z3, Z4
2012-14	1DK304-SCI	470	specify	3"	V	stk 6 rib	ProFlow	not supplied	No	not supplied	12	-	Z1, Z3, Z4

2011-20 CHRYSLER 300 HEMI (5.7) SPECIFICATIONS

Year	Part Number	OEM HP Rating	HP Gain	Tube Diam	Intercooler Mount	Drive System	Bypass System	Fuel System Upgrade	Fuel Inj. Supplied	Computer/Ignition Modifications	SC Warranty (in months)	CARB E.O.	Foot Notes
2015-20	1DK414-SCI	360	160+	3"	V	stk 6 rib	ProFlow	MAP sensor	39.5 lbs/hr	programmer sup.	12, 36 opt. (\$99)	D-365-22 (15-19)	Z1, Z2, Z3, Z4, Z6, Z7
2015-20	1DK404-SCI	360	specify	3"	V	stk 6 rib	ProFlow	not supplied	No	not supplied	12	-	Z1, Z3, Z4, Z6, Z7
2011-14	1DK414-SCI	360	160+	3"	V	stk 6 rib	ProFlow	MAP sensor	39.5 lbs/hr	programmer sup.	12, 36 opt. (\$99)	D-365-22 (12-14)	Z1, Z2, Z3, Z4, Z6
2011-14	1DK404-SCI	360	specify	3"	V	stk 6 rib	ProFlow	not supplied	No	not supplied	12	-	Z1, Z3, Z4, Z6, Z7

2005-10 CHRYSLER 300 HEMI (6.1) SPECIFICATIONS

Year	Part Number	OEM HP Rating	HP Gain	Tube Diam	Intercooler Mount	Drive System	Bypass System	Fuel System Upgrade	Fuel Inj. Supplied	Computer/Ignition Modifications	SC Warranty (in months)	CARB E.O.	Foot Notes
2005-10 (6.1)	1DE314-SCI-6.1	425	160+	3"	V	stk 6 rib	ProFlow	MAP sensor, in-tank pump	39.5 lbs/hr	programmer sup.	12, 36 opt. (\$99)	D-365-7	Z1, Z3, Z4, Z6, Z8
2005-10 (6.1)	1DE304-SCI-6.1	425	specify	3"	V	stk 6 rib	ProFlow	not supplied	No	not supplied	12	-	Z1, Z3, Z4, Z6, Z8

2005-10 CHRYSLER 300 HEMI (5.7) SPECIFICATIONS

Year	Part Number	OEM HP Rating	HP Gain	Tube Diam	Intercooler Mount	Drive System	Bypass System	Fuel System Upgrade	Fuel Inj. Supplied	Computer/Ignition Modifications	SC Warranty (in months)	CARB E.O.	Foot Notes
2005-10 (5.7)	1DE314-SCI-5.7	340/360	110+/130*	3"	V	stk 6 rib	ProFlow	MAP sensor	39.5 lbs/hr	programmer sup.	12, 36 opt. (\$99)	D-365-7	Z1, Z3, Z4, Z6, Z8
2005-10 (5.7)	1DE304-SCI-5.7	340/360	specify	3"	V	stk 6 rib	ProFlow	not supplied	No	not supplied	12	-	Z1, Z3, Z4, Z6, Z8

* 130+ hp with 2009-10 5.7L VCT engines

CHRYSLER AUTOMOTIVE FOOTNOTES (specific to above applications):

- Z1) Model year must be specified
- Z2) Due to variability among OEM computers, and the prevalence of custom modifications, dyno tuning may be required
- Z3) Specify engine size (5.7, 6.1, or 6.4)
- Z4) Systems ship in extra large box
- Z5) Purchase of aftermarket balancer required (not included - specify hardened hub):
5.7 (2005-08) = ATI PP part #918435
5.7 (2009-10) = ATI PP part #918445
6.1 = ATI PP part #918432
- Z6) 2WD models only; AWD models must use Tuner Kit and may require modifications
- Z7) 2015+ vehicles may require ECM unlock (call for details)
- Z8) 2006-10 vehicles require removal of adaptive cruise control sensor



2005-08 DODGE MAGNUM HEMI (6.1) SYSTEMS AND KITS

Year	Part Number	Description	Boost Options	HP Gain	Intercooler	Price
2005-08 (6.1)	1DE314-SCI-6.1	High Output Intercooled System with P-1SC-1	7 psi	160+	3 Core	\$7,099
2005-08 (6.1)	1DE304-SCI-6.1	High Output Intercooled Tuner Kit with P-1SC-1	specify	specify	3 Core	\$5,999

2005-08 DODGE MAGNUM HEMI (5.7) SYSTEMS AND KITS

Year	Part Number	Description	Boost Options	HP Gain	Intercooler	Price
2005-08 (5.7)	1DE314-SCI-5.7	High Output Intercooled System with P-1SC-1	7 psi	110+	3 Core	\$6,849
2005-08 (5.7)	1DE304-SCI-5.7	High Output Intercooled Tuner Kit with P-1SC-1	specify	specify	3 Core	\$5,999

2005-08 MAGNUM (6.1, 5.7) OPTIONS	add "-P" to part #	Polished finish for ProCharger (P-series or D-series)	satin standard	-	-	+\$295
	add "-P" to part #	Polished finish for ProCharger (F-series, 9" housing)	satin standard	-	-	+\$325
	add "-PHO" to part #	Polished finish for supercharger bracket	satin standard	-	-	+\$250
	add "-H" to part #	Helical gearset for noise reduction (P-1SC-1, P-1X, D-1SC, D-1X)	same	same	-	+\$100
	add "-P1X" to part #	With P-1X ProCharger (replacing P-1SC-1, Systems and Tuner Kits)	same	add'l 10-15+ hp	-	+\$200
	add "-D1SC" to part #	With D-1SC ProCharger (replacing P-1SC-1)	tuner kit only	specify	-	+\$250
	add "-D1X" to part #	With D-1X ProCharger (replacing P-1SC-1, Tuner Kits only)	tuner kit only	specify	-	+\$425
	add "-D" or "-1" or "-A"	With F-1D, F-1, F-1A ProCharger (replacing P-1SC-1)	tuner kit only	specify	-	+\$775
add "-RVR" or "RVB"	Race Bypass Valve Upgrade (specify open or closed valve)	red or black	specify	-	+\$295	

HEMI REVERSE COG RACE KITS

Engine	Part Number	Description	Boost Options	HP Gain	Intercooler	Price
5.7L or 6.1L	1DX200-F1	HEMI Reverse Cog Race Kit with F-1D, F-1, or F-1A	specify	specify	-	\$6,499

HEMI REVERSE COG RACE KIT OPTIONS	add "-C/R" to part #	With F-1C, F-1R ProCharger supercharger	From F-1/D/A	specify	-	+\$350
	add "-F1X" to part #	With F-1X ProCharger supercharger	From F-1/D/A	specify	-	+\$1,050
	A1003A-002	With sheet metal 3 core race intercooler (950 hp)	from non-ic kit	3" in/outlet	-	+\$1,170
	A1045A-001	With sheet metal 3 core race intercooler (1300 hp)	from non-ic kit	3.5" in/outlet	-	+\$1,586
	W11005A-001	With Air-to-Water race intercooler (race use only)	from non-ic kit	1,800 hp max	-	+\$2,199
	W11005A-002	With Air-to-Water race intercooler (race use only)	from non-ic kit	2,500+ hp max	-	+\$2,699

SPECIFICATIONS (2005-08 MAGNUM AND HEMI COG RACE KITS)

2005-08 DODGE MAGNUM HEMI (6.1) SPECIFICATIONS

Year	Part Number	OEM HP Rating	HP Gain	Tube Diam	Intercooler Mount	Drive System	Bypass System	Fuel System Upgrade	Fuel Inj. Supplied	Computer/Ignition Modifications	SC Warranty (in months)	CARB E.O.	Foot Notes
2005-08 (6.1)	1DE314-SCI-6.1	425	160+	3"	V	stk 6 rib	ProFlow	MAP sensor, in-tank pump	39.5 lbs/hr	programmer supplied	12, 36 opt. (\$99)	D-365-7	AA1, AA3, AA4, AA6
2005-08 (6.1)	1DE304-SCI-6.1	425	specify	3"	V	stk 6 rib	ProFlow	not supplied	No	not supplied	12	-	AA1, AA3, AA4, AA6

2005-08 DODGE MAGNUM HEMI (5.7) SPECIFICATIONS

Year	Part Number	OEM HP Rating	HP Gain	Tube Diam	Intercooler Mount	Drive System	Bypass System	Fuel System Upgrade	Fuel Inj. Supplied	Computer/Ignition Modifications	SC Warranty (in months)	CARB E.O.	Foot Notes
2005-08 (5.7)	1DE314-SCI-5.7	340	110+	3"	V	stk 6 rib	ProFlow	MAP sensor	39.5 lbs/hr	programmer supplied	12, 36 opt. (\$99)	D-365-7	AA1, AA3, AA4, AA6
2005-08 (5.7)	1DE304-SCI-5.7	340	specify	3"	V	stk 6 rib	ProFlow	not supplied	No	not supplied	12	-	AA1, AA3, AA4, AA6

HEMI REVERSE COG RACE KIT SPECIFICATIONS

Year	Part Number	OEM HP Rating	HP Gain	Tube Diam	Intercooler Mount	Drive System	Bypass System	Fuel System Upgrade	Fuel Inj. Supplied	Computer/Ignition Modifications	SC Warranty (in months)	CARB E.O.	Foot Notes
2005-10	1DX200-F1	-	specify	3"	-	50mm cog	Race	not supplied	No	not supplied	Limited	-	AA4, AA5, AA7, AA8

DODGE AUTOMOTIVE FOOTNOTES (specific to above applications):

- AA1) Model year must be specified
- AA2) Due to variability among OEM computers, and the prevalence of custom modifications, dyno tuning may be required
- AA3) Specify engine size (5.7 or 6.1)
- AA4) Systems ship in extra large box
- AA5) Purchase of aftermarket balancer required (not included - specify hardened hub):
5.7 (2006-08) = ATI PP part #918435
6.1 = ATI PP part #918432
- AA6) 2WD models only; AWD models must use Tuner Kit and may require modifications
- AA7) Requires extensive modification to engine cooling system, modified A/C condenser if A/C is retained
- AA8) Special order kit: order form and non-refundable deposit required at time of order—may require additional lead time for processing



2019-21 GM TRUCK 1500 (5.3, 6.2) SYSTEMS AND KITS

Year	Part Number	Description	Boost Options	HP Gain	Intercooler	Price
2019-21 (5.3)	1KA213-SCI	High Output Intercooled Systems with P-1SC-1	8 psi	45%+	3 core	\$8,799
2019-21 (5.3)	1KA202-SCI	High Output Intercooled Tuner Kit with P-1SC-1	specify	specify	3 core	\$6,899
2019-21 (6.2)	1KA212-SCI	High Output Intercooled Systems with P-1SC-1	8 psi	45%+	3 core	\$8,799
2019-21 (6.2)	1KA202-SCI	High Output Intercooled Tuner Kit with P-1SC-1	specify	specify	3 core	\$6,899
2019-21 (5.3/6.2)	1KA312-SCI	Stage II Intercooled System w/ P-1SC-1	8 psi	45%+	Stage II	\$9,249
2019-21 (5.3/6.2)	1KA302-SCI	Stage II Intercooled Tuner Kit w/ P-1SC-1	specify	specify	Stage II	\$7,349

2014-18 GM TRUCK / 2015-20 SUV 1500 (5.3, 6.2) SYSTEMS AND KITS

Year	Part Number	Description	Boost Options	HP Gain	Intercooler	Price
2014-18 (5.3)	1GV213-SCI	High Output Intercooled System with P-1SC-1	8 psi	45%+	3 core	\$6,599
2014-18 (5.3)	1GV202-SCI	High Output Intercooled Tuner Kit with P-1SC-1	specify	specify	3 core	\$6,199
2014-18 (6.2)	1GV212-SCI	High Output Intercooled System with P-1SC-1	8 psi	45%+	3 core	\$6,599
2014-18 (6.2)	1GV202-SCI	High Output Intercooled Tuner Kit with P-1SC-1	specify	specify	3 core	\$6,199
2014-18 (5.3/6.2)	1GV312-SCI	Stage II Intercooled System w/ P-1SC-1 (dedicated drive)	8 psi	45%+	3 core	\$7,099
2014-18 (5.3/6.2)	1GV302-SCI	Stage II Intercooled Tuner Kit w/ P-1SC-1 (dedicated drive)	specify	specify	3 core	\$6,799

2015-19 GM TRUCK 2500 (6.0) SYSTEMS AND KITS

Year	Part Number	Description	Boost Options	HP Gain	Intercooler	Price
2015-19	1GV314-SCI	High Output Intercooled Systems with P-1SC-1	7-8 psi	45%+	3 core	\$6,799
2015-19	1GV304-SCI	High Output Intercooled Tuner Kit with P-1SC-1	specify	specify	3 core	\$5,899

Year	Part Number	Description	Boost Options	HP Gain	Intercooler	Price
2014-21 GM TRUCK/SUV (5.3, 6.0, 6.2) OPTIONS	add "-B" or "-P" to part #	Black or Polished finish for ProCharger (P-series or D-series)	satin standard	-	-	+\$295
	add "-B" or "-P" to part #	Black or Polished finish for ProCharger (F-series, 9" or 9.75" housing)	satin standard	-	-	+\$325
	add "-B" or "-P" to part #	Black or Polished finish for ProCharger (F-series, 10.5" housing)	satin standard	-	-	+\$375
	add "-BB" or "-PB" to part #	Black or Polished finish for supercharger bracket	satin standard	-	-	+\$250
	add "-H" to part #	Helical gearset for noise reduction (P-1SC-1, P-1X, D-1SC, D-1X)	same	same	-	+\$100
	add "-P1X" to part #	With P-1X ProCharger (replacing P-1SC-1, Systems and Tuner Kits)	same	add'l 10-15+ hp	-	+\$200
	add "-D1SC" to part #	With D-1SC ProCharger (replacing P-1SC-1)	tuner kit only	specify	-	+\$250
	add "-D1X" to part #	With D-1X ProCharger (replacing P-1SC-1, Tuner Kits only)	tuner kit only	specify	-	+\$425
	add "-VI" to part #	Vertical Intercooler Option (from 3 core Horizontal)	from horizontal	950 hp max	-	+\$195
	add "-FA" to part #	Forward facing air inlet (rear facing is standard, HO only)	same	same	-	+\$119
	add "-D" or "-1" or "-A"	With F-1D, F-1, F-1A ProCharger (replacing P-1SC-1)	tuner kit only	specify	-	+\$775
	add "-94" or "-C" or "-R"	With F-1A-94, F-1C or F-1R (replacing P-1SC-1, Stage II only)	tuner kit only	-	-	+\$1,100
	add "-F1X" to part #	With F-1X ProCharger (replacing P-1SC-1, Stage II only)	tuner kit only	specify	-	+\$2,030
	add "-RVR" or "-RVB"	Race Bypass Valve Upgrade (Stage II only)	red or black	specify	-	+\$295
add "-Race" to part #	Air-to-Air Race Intercooler Upgrade (Stage II Tuner Kit only)	from 3 core	1300 hp max	-	+\$345	

SPECIFICATIONS (2014-21 CHEVROLET/GMC/CADILLAC TRUCK/SUV)

2019-21 GM TRUCK 1500 (5.3, 6.2) SYSTEMS AND KITS

Year	Part Number	OE HP/TQ Rating	HP Gain	Tube Diam	IC Mount	Drive System	Bypass System	Fuel System Upgrade	Fuel Inj. Supplied	Computer/Ignition Modifications	SC Warranty (in months)	CARB E.O.	Foot Notes
2019-21 (5.3)	1KA213-SCI	355/383	45%+	3"	V	add'l 8 rib	Bullet	not required	not required	programmer sup.	12, 36 opt. (\$99)	-	BB1, BB2, BB4, BB5, BB6
2019-21 (5.3)	1KA202-SCI	355/383	specify	3"	V	add'l 8 rib	Bullet	not supplied	No	not supplied	12	-	BB1, BB2, BB5
2019-21 (6.2)	1KA212-SCI	420/460	45%+	3"	V	add'l 8 rib	Bullet	not required	not required	programmer sup.	12, 36 opt. (\$99)	-	BB1, BB2, BB4, BB5, BB6
2019-21 (6.2)	1KA202-SCI	420/460	specify	3"	V	add'l 8 rib	Bullet	not supplied	No	not supplied	12	-	BB1, BB2, BB5
2019-21 (5.3/6.2)	1KA312-SCI	420/460	45%+	3"	V	add'l 8 rib	Bullet	not required	not required	programmer sup.	12, 36 opt. (\$99)	-	BB1, BB2, BB4, BB5, BB6
2019-21 (5.3/6.2)	1KA302-SCI	420/460	specify	3"	V	add'l 8 rib	Bullet	not supplied	No	not supplied	12	-	BB1, BB2, BB5

2014-18 GM TRUCK / 2015-20 SUV 1500 (5.3, 6.2) SPECIFICATIONS

Year	Part Number	OE HP/TQ Rating	HP Gain	Tube Diam	IC Mount	Drive System	Bypass System	Fuel System Upgrade	Fuel Inj. Supplied	Computer/Ignition Modifications	SC Warranty (in months)	CARB E.O.	Foot Notes
2014-18 (5.3)	1GV213-SCI	355/383	45%+	3"	H / V	stk 6 rib	ProFlow	not required	not required	programmer sup.	12, 36 opt. (\$99)	D-365-10 (14-15)	BB1, BB2, BB3, BB5, BB7
2014-18 (5.3)	1GV202-SCI	355/383	specify	3"	H / V	stk 6 rib	ProFlow	not supplied	No	not supplied	12	-	BB1, BB2, BB3, BB5, BB7
2014-18 (6.2)	1GV212-SCI	420/460	45%+	3"	H / V	stk 6 rib	ProFlow	not required	not required	programmer sup.	12, 36 opt. (\$99)	D-365-10 (14-15)	BB1, BB2, BB3, BB5, BB7
2014-18 (6.2)	1GV202-SCI	420/460	specify	3"	H / V	stk 6 rib	ProFlow	not supplied	No	not supplied	12	-	BB1, BB2, BB3, BB5, BB7
2014-18 (5.3/6.2)	1GV312-SCI	-	45%+	3"	H / V	add'l 8 rib	ProFlow	not required	not required	programmer sup.	12, 36 opt. (\$99)	-	BB1, BB2, BB3, BB5, BB6, BB7, BB8
2014-18 (5.3/6.2)	1GV302-SCI	-	specify	3"	H / V	add'l 8 rib	ProFlow	not supplied	No	not supplied	12	-	BB1, BB2, BB3, BB5, BB7, BB8

2015-19 GM TRUCK 2500 (6.0) SPECIFICATIONS

Year	Part Number	OE HP/TQ Rating	HP Gain	Tube Diam	IC Mount	Drive System	Bypass System	Fuel System Upgrade	Fuel Inj. Supplied	Computer/Ignition Modifications	SC Warranty (in months)	CARB E.O.	Foot Notes
2015-19	1GV314-SCI	360/380	45%+	3"	V	stk 6 rib	ProFlow	not required	56 lb/hr	programmer sup.	12, 36 opt. (\$99)	-	BB1, BB2, BB4, BB5, BB6
2015-19	1GV304-SCI	360/380	specify	3"	V	stk 6 rib	ProFlow	not supplied	No	not supplied	12	-	BB1, BB2, BB5

CHEVY TRUCK/SUV FOOTNOTES (specific to above applications):

- BB1) Model year must be specified
- BB2) Specify 2WD or 4WD, Truck or SUV, and GMC or Chevrolet
- BB3) Specify engine size
- BB4) For Flex Fuel vehicles, gasoline-only tune provided, not E85
- BB5) Due to the wide variance of chassis and options available, modifications may be required
- BB6) Due to variability among OEM computers, and the prevalence of custom modifications, dyno tuning may be required
- BB7) 2017-18 Trucks require vertical intercooler; 2017-18 SUV's require horizontal intercooler
- BB8) Specify stock or aftermarket balancer (IW #760 or ATI #918645 + #916358 specify hardened hub)



2007-13 GM TRUCK / 2007-14 SUV 1500 (5.3, 4.8) SYSTEMS AND KITS (LATE 2007-2013)

Year	Part Number	Description	Boost Options	HP Gain	Intercooler	Price
2007-13 (4.8)	1GR212-SCI	High Output Intercooled System with P-1SC-1	8-9 psi	50-55%	2 core	\$6,649
2007-13 (5.3)	1GR212-SCI	High Output Intercooled System with P-1SC-1	8-9 psi	50-55%	2 core	\$6,649
2007-13 (4.8 / 5.3)	1GR202-SCI	High Output Intercooled Tuner Kit with P-1SC-1	specify	specify	2 core	\$5,849
2007-13 (4.8)	1GR312-SCI	Stage II Intercooled System with P-1SC-1 (dedicated drive)	8-9 psi	50-55%	2 core	\$6,999
2007-13 (5.3)	1GR312-SCI	Stage II Intercooled System with P-1SC-1 (dedicated drive)	8-9 psi	50-55%	2 core	\$6,999
2007-13 (4.8 / 5.3)	1GR302-SCI	Stage II Intercooled Tuner Kit with P-1SC-1 (dedicated drive)	specify	specify	2 core	\$6,199

2007-13 GM TRUCK / 2007-14 SUV 1500 (6.0, 6.2) SYSTEMS AND KITS (LATE 2007-2013)

Year	Part Number	Description	Boost Options	HP Gain	Intercooler	Price
2007-09 (6.0)	1GR212-SCI	High Output Intercooled System with P-1SC-1	7-8 psi	50%+	3 core	\$6,999
2007-09 (6.0)	1GR202-SCI	High Output Intercooled Tuner Kit with P-1SC-1	specify	specify	3 core	\$6,199
2007-13 (6.2)	1GR213-SCI	High Output Intercooled System with P-1SC-1	7-8 psi	50%+	3 core	\$6,999
2007-13 (6.2)	1GR202-SCI	High Output Intercooled Tuner Kit with P-1SC-1	specify	specify	3 core	\$6,199
2007-13 (6.0 / 6.2)	1GR312-SCI	Stage II Intercooled System w/ P-1SC-1 (dedicated drive)	7-8 psi	50%+	3 core	\$7,299
2007-13 (6.0 / 6.2)	1GR302-SCI	Stage II Intercooled Tuner Kit w/ P-1SC-1 (dedicated drive)	specify	specify	3 core	\$6,399

2007-13 GM TRUCK/SUV (5.3, 6.0, 6.2, 4.8) OPTIONS	add "-B" or "-P" to part #	Black or Polished finish for ProCharger (P-series or D-series)	satin standard	-	-	+\$295
	add "-B" or "-P" to part #	Black or Polished finish for ProCharger (F-series, 9" or 9.75" housing)	satin standard	-	-	+\$325
	add "-B" or "-P" to part #	Black or Polished finish for ProCharger (F-series, 10.5" housing)	satin standard	-	-	+\$375
	add "-B" or "-P" to part #	Black or Polished finish for ProCharger (F-series, 12" housing)	satin standard	-	-	+\$425
	add "-BB" or "-PB" to part #	Black or Polished finish for supercharger bracket	satin standard	-	-	+\$250
	add "-H" to part #	Helical gearset for noise reduction (P-1SC-1, P-1X, D-1SC, D-1X)	same	same	-	+\$100
	add "-P1X" to part #	With P-1X ProCharger (replacing P-1SC-1, Systems and Tuner Kits)	same	add'l 10-15+ hp	-	+\$200
	add "-D1SC" to part #	With D-1SC ProCharger (replacing P-1SC-1)	tuner kit only	specify	-	+\$250
	add "-D1X" to part #	With D-1X ProCharger (replacing P-1SC-1, Tuner Kits only)	tuner kit only	specify	-	+\$425
	add "-D" or "-1" or "-A"	With F-1D, F-1, F-1A ProCharger (replacing P-1SC-1)	tuner kit only	specify	-	+\$775
	add "-94" to part #	With F-1A-94 ProCharger (replacing P-1SC-1)	tuner kit only	specify	-	+\$1,100
	add "-C" or "-R" to part #	With F-1C, or F-1R ProCharger (replacing P-1SC-1, Stage II Kits only)	tuner kit only	specify	-	+\$1,100
	add "-F2" to part #	With F-1X ProCharger (replacing P-1SC-1, Stage II Kits only)	tuner kit only	specify	-	+\$2,030
	add "-RVR" or "RVB"	Race Bypass Valve Upgrade (specify open or closed valve)	red or black	specify	-	+\$295
	add "-FA" to part #	Forward facing air inlet (rear facing is standard, HO only)	same	same	-	+\$119
add "-VI" to part #	Vertical Intercooler (from 3 core Horizontal, truck only, Stage II only)	from horizontal	950 hp max	-	+\$195	
add "-3C" to part #	3 core intercooler system upgrade	from 2 core	825 hp max	3" tubing	+\$345	
	3GKMM-004	Crank Pin Kit	-	-	-	+\$99

2007-13 GM TRUCK/SUV 1500/2500 (5.3, 6.0, 6.2, 4.8) i-1 PROGRAMMABLE RATIO SYSTEMS

Year	Part Number	Description	Boost Options	HP Gain	Intercooler	Price
2007-13 (4.8)	1GR215-SCI	High Output Intercooled System with i-1	8-9 psi	55-60%+	3 core	\$8,699
2007-13 (5.3)	1GR215-SCI	High Output Intercooled System with i-1	8-9 psi	55-60%+	3 core	\$8,699
2007-13 (6.0)	1GR215-SCI	High Output Intercooled System with i-1	7-8 psi	50-55%+	3 core	\$8,699
2007-13 (6.2)	1GR215-SCI	High Output Intercooled System with i-1	7-8 psi	50-55%+	3 core	\$8,699

GM TRUCK/SUV I-1 OPTIONS	add "-T" to part #	Touchscreen (at time of system purchase)	-	-	-	+\$395
	add "-V" to part #	Vertical Intercooler Option (from 3 Core Horizontal)	from horizontal	900 hp max	-	+\$195
	add "-P" to part #	Polished finish (supercharger and bracket)	satin standard	-	-	+\$595
	add "-B" to part #	Black finish (supercharger and bracket)	satin standard	-	-	+\$795

SPECIFICATIONS (2007-13 CHEVROLET/GMC/CADILLAC TRUCK/SUV)

2007-13 GM TRUCK / 2007-14 SUV 1500 (5.3, 4.8) SPECIFICATIONS (LATE 2007-2013)

Year	Part Number	OE HP/TQ Rating	HP Gain	Tube Diam	IC Mount	Drive System	Bypass System	Fuel System Upgrade	Fuel Inj. Supplied	Computer/Ignition Modifications	SC Warranty (in months)	CARB E.O.	Foot Notes
2007-13 (4.8)	1GR212-SCI	295/305	50-55%	3"	H	stk 6 rib	ProFlow	not required	52 lb/hr	programmer sup.	12, 36 opt. (\$99)	D-365-10	CC1, CC2, CC3, CC5, CC7, CC9
2007-13 (5.3)	1GR212-SCI	315/338	50-55%	3"	H	stk 6 rib	ProFlow	not required	52 lb/hr	programmer sup.	12, 36 opt. (\$99)	D-365-10	CC1, CC2, CC3, CC4, CC5, CC7, CC9
2007-13 (4.8/5.3)	1GR202-SCI	-	specify	3"	H	stk 6 rib	ProFlow	not supplied	No	not supplied	12	-	CC1, CC2, CC3, CC5, CC7, CC9
2007-13 (4.8)	1GR312-SCI	295/305	50-55%	3"	H	add'l 8 rib	ProFlow	not required	52 lb/hr	programmer sup.	12, 36 opt. (\$99)	-	CC1, CC2, CC3, CC5, CC6, CC7, CC9, CC10
2007-13 (5.3)	1GR312-SCI	315/338	50-55%	3"	H	add'l 8 rib	ProFlow	not required	52 lb/hr	programmer sup.	12, 36 opt. (\$99)	-	CC1, CC2, CC3, CC4, CC5, CC6, CC7, CC9, CC10
2007-13 (4.8/5.3)	1GR302-SCI	-	specify	3"	H	add'l 8 rib	ProFlow	not supplied	No	not supplied	12	-	CC1, CC2, CC3, CC5, CC7, CC9, CC10

2007-13 GM TRUCK / 2007-14 SUV 1500 (6.0, 6.2) SPECIFICATIONS (LATE 2007-2013)

Year	Part Number	OE HP/TQ Rating	HP Gain	Tube Diam	IC Mount	Drive System	Bypass System	Fuel System Upgrade	Fuel Inj. Supplied	Computer/Ignition Modifications	SC Warranty (in months)	CARB E.O.	Foot Notes
2007-09 (6.0)	1GR212-SCI	367/375	50%+	3"	H	stk 6 rib	ProFlow	pump volt. boost.	52 lb/hr	programmer sup.	12, 36 opt. (\$99)	D-365-10	CC1, CC2, CC3, CC4, CC5, CC7, CC8, CC9
2007-09 (6.0)	1GR202-SCI	367/375	specify	3"	H	stk 6 rib	ProFlow	not supplied	No	not supplied	12	-	CC1, CC2, CC3, CC5, CC7, CC8, CC9
2007-13 (6.2)	1GR213-SCI	380/417	50%+	3"	H	stk 6 rib	ProFlow	pump volt. boost.	65 lb/hr	programmer sup.	12, 36 opt. (\$99)	D-365-10	CC1, CC2, CC3, CC4, CC5, CC7, CC9
2007-13 (6.2)	1GR202-SCI	380/417	specify	3"	H	stk 6 rib	ProFlow	not supplied	No	not supplied	12	-	CC1, CC2, CC3, CC5, CC7, CC9
2007-13 (6.0 / 6.2)	1GR312-SCI	-	50%+	3"	H	add'l 8 rib	ProFlow	pump volt. boost.	52/65 lb/hr	programmer sup.	12, 36 opt. (\$99)	-	CC1, CC2, CC3, CC4, CC5, CC6, CC7, CC9, CC10
2007-13 (6.0 / 6.2)	1GR302-SCI	-	specify	3"	H	add'l 8 rib	ProFlow	not supplied	No	not supplied	12	-	CC1, CC2, CC3, CC5, CC7, CC9, CC10

2007-13 GM TRUCK/SUV 1500/2500 (5.3, 6.0, 6.2, 4.8) i-1 PROGRAMMABLE RATIO SPECIFICATIONS

Year	Part Number	OE HP/TQ Rating	HP Gain	Tube Diam	IC Mount	Drive System	Bypass System	Fuel System Upgrade	Fuel Inj. Supplied	Computer/Ignition Modifications	SC Warranty (in months)	CARB E.O.	Foot Notes
2007-13 (4.8)	1GR215-SCI	295/305	55-60%	3"	H	add'l 8 rib	ProFlow	not required	52 lb/hr	programmer sup.	12, 36 opt. (\$149)	-	CC1, CC2, CC3, CC5, CC6, CC9
2007-13 (5.3)	1GR215-SCI	315/338	55-60%	3"	H	add'l 8 rib	ProFlow	not required	52 lb/hr	programmer sup.	12, 36 opt. (\$149)	-	CC1, CC2, CC3, CC5, CC6, CC9
2007-13 (6.0)	1GR215-SCI	360/380	55%+	3"	H	add'l 8 rib	ProFlow	pump volt. boost.	52 lb/hr	programmer sup.	12, 36 opt. (\$149)	-	CC1, CC2, CC3, CC5, CC6, CC8, CC9
2007-13 (6.2)	1GR215-SCI	380/417	55%+	3"	H	add'l 8 rib	ProFlow	pump volt. boost.	65 lb/hr	programmer sup.	12, 36 opt. (\$149)	-	CC1, CC2, CC3, CC5, CC6, CC9

CHEVY TRUCK/SUV FOOTNOTES (specific to above applications):

- CC1) Model year must be specified
- CC2) Specify 2WD or 4WD, Truck or SUV
- CC3) Specify engine size
- CC4) For Flex Fuel vehicles, gasoline-only tune provided, not E85
- CC5) Due to the wide variance of chassis and options available, modifications may be required
- CC6) Due to variability among OEM computers, and the prevalence of custom modifications, dyno tuning may be required
- CC7) 2007 Classic use 1GI213-SCI (HO Intercooled System) or 1GI203-SCI (HO Intercooled Tuner Kit)
- CC8) HD models with Hydroboost may require modifications to power steering reservoir
- CC9) Pinning the balancer to the crank is recommended; Pin kit for stock balancer not supplied
- CC10) Specify stock or optional ATI Balancer #918635 (not included - specify hardened hub)

2003-07 GM TRUCK/SUV (5.3, 6.0, 4.8) SYSTEMS AND KITS

Year	Part Number	Description	Boost Options	HP Gain	Intercooler	Price
2003-07 (4.8/5.3)	1GI213-SCI	High Output Intercooled System with P-1SC (4.8 / 5.3)	8-9 psi	60-65%	2 core	\$6,499
2003-07 (6.0)	1GI213-SCI	High Output Intercooled System with P-1SC (6.0)	7-8 psi	55-60%	2 core	\$6,499
2003-07	1GI203-SCI	High Output Intercooled Tuner Kit with P-1SC (4.8 / 5.3 / 6.0)	specify	specify	2 core	\$5,849
2003-07	Call	Stage II Intercooled Tuner Kit with P-1SC-1 (dedicated drive)	specify	specify	2 core	\$6,249

2003-09 HUMMER H2 (6.2, 6.0) TUNER KITS

Year	Part Number	Description	Boost Options	HP Gain	Intercooler	Price
2008-09 (6.2)	1GL302-SCI	High Output Intercooled Tuner Kit with P-1SC-1 (6.2)	specify	specify	H2	\$6,149
2003-07 (6.0)	1GL202-SCI	High Output Intercooled Tuner Kit with P-1SC (6.0)	specify	specify	H2	\$6,099

1999-03 GM TRUCK/SUV (5.3, 6.0, 4.8) SYSTEMS AND KITS (CABLE THROTTLE CONTROL)

Year	Part Number	Description	Boost Options	HP Gain	Intercooler	Price
1999-03 (4.8/5.3)	1GI212-SCI	High Output Intercooled System with P-1SC (4.8 / 5.3)	8-9 psi	60-65%	2 core	\$6,149
1999-03 (6.0)	1GI212-SCI	High Output Intercooled System with P-1SC (6.0)	7-8 psi	55-60%	2 core	\$6,149
1999-03	1GI202-SCI	High Output Intercooled Tuner Kit with P-1SC (4.8 / 5.3 / 6.0)	specify	specify	2 core	\$5,899
1999-03	Call	Stage II Intercooled Tuner Kit with P-1SC-1 (dedicated drive)	specify	specify	2 core	\$6,249

1999-07 GM 2500 TRUCK (6.0) KITS

Year	Part Number	Description	Boost Options	HP Gain	Intercooler	Price
1999-07 (6.0)	1GI304-SCI	High Output Intercooled Tuner Kit with P-1SC-1	specify	specify	3 core	\$6,249
1999-07 (6.0)	1GI404-SCI	Stage II Intercooled Tuner Kit with P-1SC-1	specify	specify	3 core	\$6,599

1999-07 GM TRUCK/SUV, HUMMER H2 (5.3, 6.0, 6.2, 4.8) OPTIONS	add "-P" to part #	Polished finish for ProCharger (P-series or D-series)	head unit only	-	-	+\$295
	add "-PB" to part #	Polished finish for supercharger bracket	satn standard	-	-	+\$250
	add "-3C" to part #	3 core intercooler system upgrade (GM Truck/SUV only)	from 2 core	825 hp max	3" tubing	+\$345
	add "-H" to part #	Helical gearset for noise reduction (P-1SC, P-1SC-1, D-1SC)	same	same	-	+\$100
	add "-D1SC" to part #	With D-1SC ProCharger (replacing P-1SC)	tuner kit only	specify	-	+\$480
	add "-94" to part #	With F-1A-94 ProCharger (replacing P-1SC-1 - Stage II Kits only)	tuner kit only	specify	-	+\$1,100
	add "-F2" to part #	With F-1X ProCharger (replacing P-1SC-1, Stage II Kits only)	tuner kit only	specify	-	+\$2,030
add "-D1SC" to part #	With D-1SC ProCharger (replacing P-1SC-1)	tuner kit only	-	-	+\$230	
	3GKMM-004	Crank Pin Kit	-	-	-	+\$99

1996-00 GM TRUCK/SUV (5.7, 7.4) SYSTEMS

Year	Part Number	Description	Boost Options	HP Gain	Intercooler	Price
1996-00 (5.7)	1GH212-SCI	High Output Intercooled System with P-1SC (5.7)	8-9 psi	60-65%	2 core	\$6,099
1996-00 (5.7)	1GH202-SCI	High Output Intercooled Tuner Kit with P-1SC (5.7)	8-9 psi	60-65%	2 core	\$5,849
1996-00 (7.4)	1GG202-SCI	High Output Intercooled Tuner Kit with P-1SC (7.4)	specify	specify	2 core	\$5,849

1988-95 GM TBI TRUCK/SUV (5.7, 7.4) SYSTEMS

Year	Part Number	Description	Boost Options	HP Gain	Intercooler	Price
1988-95 (5.7)	1GD212-SCI	High Output Intercooled System with P-1SC (5.7)	8-9 psi	60-65%	2 core	\$5,399
1988-95 (5.7)	1GD202-SCI	High Output Intercooled Tuner Kit with P-1SC (5.7)	8-9 psi	60-65%	2 core	\$5,199
1988-95 (5.7)	1GD212-09I	High Output Intercooled System with P600B (5.7)	8-9 psi	60-65%	2 core	\$5,099
1988-95 (7.3)	1GE212-SCI	High Output Intercooled System with P-1SC (7.4)	8-9 psi	60-65%	2 core	\$5,399
1988-95 (7.3)	1GE202-SCI	High Output Intercooled Tuner Kit with P-1SC (7.4)	8-9 psi	60-65%	2 core	\$5,199
1988-95 (7.3)	1GE212-09I	High Output Intercooled System with P600B (7.4)	8-9 psi	60-65%	2 core	\$5,099

1988-00 GM TRUCK/SUV (5.7, 7.4)	add "-P" to part #	Polished finish for ProCharger (P-series or D-series)	satn standard	-	-	+\$295
	add "-H" to part #	Helical gearset for noise reduction (P-1SC)	same	same	-	+\$100
	add "-D1SC" to part #	With D-1SC ProCharger (replacing P-1SC)	specify	specify	-	+\$480
	add "-D1" to part #	With D-1 ProCharger (replacing P600B, 1988-95 only)	specify	specify	-	+\$650

SPECIFICATIONS (1988-2007 CHEVROLET/GMC/CADILLAC/H2 TRUCK/SUV)

2003-07 GM TRUCK/SUV (5.3, 6.0, 4.8) SPECIFICATIONS

Year	Part Number	OEM HP/TQ Rating	HP Gain	Tube Diam	IC Mount	Drive System	Bypass System	Fuel System Upgrade	Fuel Inj. Supplied	Computer/Ignition Modifications	SC Warranty (in months)	CARB E.O.	Foot Notes
2003-07 (4.8/5.3)	1GI213-SCI	285/325	60-65%	3"	H	stk 6 rib	ProFlow	not required	44 lb/hr	programmer sup.	12, 36 opt. (\$99)	D-365-10 (5.3 04-06)	All except DD8 and DD11
2003-07 (6.0)	1GI213-SCI	320/360	55-60%	3"	H	stk 6 rib	ProFlow	not required	44 lb/hr	programmer sup.	12, 36 opt. (\$99)	D-365-10 (04-06)	All except DD8 and DD11
2003-07	1GI203-SCI	-	specify	3"	H	stk 6 rib	ProFlow	not supplied	not supp'd	not supplied	12	-	DD1, DD2, DD4, DD5, DD7, DD9, DD10
2003-07	Call	-	specify	3"	H	add'l 8 rib	ProFlow	not supplied	not supp'd	not supplied	12	-	DD1, DD2, DD4, DD5, DD7, DD9, DD10

2003-09 HUMMER H2 (6.2, 6.0) SPECIFICATIONS

Year	Part Number	OEM HP/TQ Rating	HP Gain	Tube Diam	IC Mount	Drive System	Bypass System	Fuel System Upgrade	Fuel Inj. Supplied	Computer/Ignition Modifications	SC Warranty (in months)	CARB E.O.	Foot Notes
2008-09 (6.2)	1GL302-SCI	393/415	specify	2.5"	V	stk 6 rib	ProFlow	not supplied	No	not supplied	12	-	DD9, DD10, DD11
2003-07 (6.0)	1GL202-SCI	316/360	specify	3"	H	stk 6 rib	ProFlow	none supplied	No	not supplied	12	-	DD9, DD10, DD11

1999-03 GM TRUCK/SUV (5.3, 6.0, 4.8) SPECIFICATIONS (CABLE THROTTLE CONTROL)

Year	Part Number	OEM HP/TQ Rating	HP Gain	Tube Diam	IC Mount	Drive System	Bypass System	Fuel System Upgrade	Fuel Inj. Supplied	Computer/Ignition Modifications	SC Warranty (in months)	CARB E.O.	Foot Notes
1999-03 (5.3, 4.8)	1GI212-SCI	285/325	60-65%	3"	H	stk 6 rib	ProFlow	ProPump, FMU	not req'd	not required	12, 36 opt. (\$99)	D-365-10	DD1, DD2, DD3, DD4, DD5, DD7, DD9
1999-03 (6.0)	1GI212-SCI	320/360	55-60%	3"	H	stk 6 rib	ProFlow	ProPump, FMU	not req'd	not required	12, 36 opt. (\$99)	D-365-10	DD1, DD2, DD3, DD4, DD5, DD7, DD9
1999-03	1GI202-SCI	-	specify	3"	H	stk 6 rib	ProFlow	not supplied	not supp'd	not supplied	12	-	DD1, DD2, DD4, DD5, DD7, DD9, DD10
1999-03	Call	-	specify	3"	H	add'l 8 rib	ProFlow	not supplied	not supp'd	not supplied	12	-	DD1, DD2, DD4, DD5, DD7, DD9, DD10

1999-07 GM 2500 TRUCK (6.0) SPECIFICATIONS

Year	Part Number	OEM HP/TQ Rating	HP Gain	Tube Diam	IC Mount	Drive System	Bypass System	Fuel System Upgrade	Fuel Inj. Supplied	Computer/Ignition Modifications	SC Warranty (in months)	CARB E.O.	Foot Notes
1999-07 (6.0)	1GI304-SCI	-	specify	3"	H/V	stk 6 rib	ProFlow	not supplied	not supp'd	not supplied	12	-	DD1, DD2, DD4, DD5, DD7, DD9, DD10, DD12, DD13
1999-07 (6.0)	1GI404-SCI	-	specify	3"	H/V	add'l 8 rib	ProFlow	not supplied	not supp'd	not supplied	12	-	DD1, DD2, DD4, DD5, DD7, DD9, DD10, DD12, DD13

1996-00 GM TRUCK/SUV (5.7, 7.4) SPECIFICATIONS

Year	Part Number	OEM HP/TQ Rating	HP Gain	Tube Diam	IC Mount	Drive System	Bypass System	Fuel System Upgrade	Fuel Inj. Supplied	Computer/Ignition Modifications	SC Warranty (in months)	CARB E.O.	Foot Notes
1996-00 (5.7)	1GH212-SCI	250/335	60-65%	3"	H	stk 6 rib	ProFlow	ProPump, FMU	not req'd	MAF massager	12, 36 opt. (\$99)	D-365-3	DD1, DD2, DD11
1996-00 (5.7)	1GH202-SCI	250/335	specify	3"	H	stk 6 rib	ProFlow	not supplied	not req'd	not supplied	12	-	DD1, DD2, DD11
1996-00 (7.4)	1GG202-SCI	290/410	specify	3"	H	stk 6 rib	ProFlow	not supplied	not req'd	not supplied	12	-	DD1, DD2, DD11

1988-95 GM TBI TRUCK/SUV (5.7, 7.4) SPECIFICATIONS

Year	Part Number	OEM HP/TQ Rating	HP Gain	Tube Diam	IC Mount	Drive System	Bypass System	Fuel System Upgrade	Fuel Inj. Supplied	Computer/Ignition Modifications	SC Warranty (in months)	CARB E.O.	Foot Notes
1988-95 (5.7)	1GD212-SCI	210/300	60-65%	3"	H	stk 6 rib	ProFlow	ProPump, FMU	not req'd	not required	12, 36 opt. (\$99)	D-365-3	DD1, DD2, DD11
1988-95 (5.7)	1GD202-SCI	210/300	60-65%	3"	H	stk 6 rib	ProFlow	not supplied	not req'd	not required	12	-	DD1, DD2, DD11
1988-95 (5.7)	1GD212-09I	210/300	60-65%	3"	H	stk 6 rib	ProFlow	ProPump, FMU	not req'd	not required	36	-	DD1, DD2, DD11
1988-95 (7.4)	1GE212-SCI	230/385	60-65%	3"	H	stk 6 rib	ProFlow	ProPump, FMU	not req'd	not required	12, 36 opt. (\$99)	D-365-3	DD1, DD2, DD11
1988-95 (7.4)	1GE202-SCI	230/385	60-65%	3"	H	stk 6 rib	ProFlow	not supplied	not req'd	not required	12	-	DD1, DD2, DD11
1988-95 (7.4)	1GE212-09I	230/385	60-65%	3"	H	stk 6 rib	ProFlow	ProPump, FMU	not req'd	not required	36	-	DD1, DD2, DD11

CHEVY TRUCK/SUV FOOTNOTES (specific to above applications):

- DD1) Model year must be specified
- DD2) Specify 2WD or 4WD, Truck or SUV
- DD3) Specify engine size
- DD4) Modifications and custom tuning required for HD/2500 Series applications (Tuner Kits only)
- DD5) Specify if hydroboost option
- DD6) For Flex Fuel vehicles, gasoline-only tune provided, not E85

- DD7) Due to the wide variance of chassis and options available, modifications may be required
- DD8) Due to variability among OEM computers, and prevalence of custom mods, dyno tuning may be required
- DD9) Pinning the balancer to the crank is recommended; Pin kit for stock balancer not supplied
- DD10) System ships in extra large box
- DD11) Special order kit: order form and non-refundable deposit required at time of order—may require additional lead time for processing
- DD12) Electric fan conversion required (sold separately by others)
- DD13) HD models with Hydroboost may require modifications to power steering reservoir

2020-21 FORD F-250/350 SUPER DUTY (7.3) SYSTEMS AND KITS

Year	Part Number	Description	Boost Options	HP Gain	Intercooler	Price
2020-21	1FZ211-SCI	High Output Intercooled System	7-8 psi	50%+	3 core	\$7,599
2020-21	1FZ201-SCI	High Output Intercooled Tuner Kit	specify	specify	3 core	\$6,399

2015-20 FORD F-150 (5.0 4V) SYSTEMS AND KITS

Year	Part Number	Description	Boost Options	HP Gain	Intercooler	Price
2018-20	1FY411-SCI	High Output Intercooled System with P-1SC-1	6 psi	50-55%+	3 core	\$6,999
2018-20	1FY401-SCI	High Output Intercooled Tuner Kit with P-1SC-1	specify	specify	3 core	\$6,549
2018-20	1FY511-SCI	Stage II Intercooled System with P-1SC-1	8 psi	60-65%+	Race	\$7,299
2018-20	1FY501-SCI	Stage II Intercooled Tuner Kit with P-1SC-1	specify	specify	Race	\$6,849
2015-17	1FY211-SCI	High Output Intercooled System with P-1SC-1	6-7 psi	45-55%	3 core	\$6,849
2015-17	1FY201-SCI	High Output Intercooled Tuner Kit with P-1SC-1	specify	specify	3 core	\$6,499
2015-17	1FY311-SCI	Stage II Intercooled System with P-1SC-1	8-9 psi	60-70%	Race	\$7,349
2015-17	1FY301-SCI	Stage II Intercooled Tuner Kit with P-1SC-1	specify	specify	Race	\$6,799

2011-14 FORD F-150 (5.0, 6.2 4V) SYSTEMS AND KITS

Year	Part Number	Description	Boost Options	HP Gain	Intercooler	Price
2011-14 (5.0)	1FV211-SCI-5.0	High Output Intercooled System with P-1SC-1	6-7 psi	45-55%	3 core	\$6,449
2011-14 (5.0)	1FV201-SCI-5.0	High Output Intercooled Tuner Kit with P-1SC-1	specify	specify	3 core	\$6,099
2011-14 (5.0)	1FV311-SCI-5.0	Stage II Intercooled System with P-1SC-1	8-9 psi	60-70%	Race	\$6,949
2011-14 (5.0)	1FV301-SCI-5.0	Stage II Intercooled Tuner Kit with P-1SC-1	specify	specify	Race	\$6,399
2011-14 (6.2)	1FS311-SCI-6.2	High Output Intercooled System with D-1SC (6.2)	7-8 psi	50%+	3 core	\$7,099
2011-14 (6.2)	1FS301-SCI-6.2	High Output Intercooled Tuner Kit with D-1SC (6.2)	specify	specify	3 core	\$6,249
2011-14 (6.2)	1FS211-SCI-6.2	Stage II Intercooled System with P-1SC-1 (6.2)	7-8 psi	50%+	3 core	\$7,199
2011-14 (6.2)	1FS201-SCI-6.2	Stage II Intercooled Tuner Kit with P-1SC-1 (6.2)	specify	specify	3 core	\$6,349

2020-21 SUPER DUTY (7.3) / 2011-20 F-150 (5.0, 6.2 4V) OPTIONS	add "-B" or "-P" to part #	Black or Polished finish for ProCharger (P-series or D-series)	satin standard	-	-	+\$295
	add "-B" or "-P" to part #	Black or Polished finish for ProCharger (F-series, 9" housing)	satin standard	-	-	+\$325
	add "-BB" or "-PB" to part #	Black or Polished finish for supercharger bracket	satin standard	-	-	+\$250
	add "-H" to part #	Helical gasket for noise reduction (P-1SC-1, P-1X, D-1SC, D-1X)	same	same	-	+\$100
	add "-P1X" to part #	With P-1X ProCharger (replacing P-1SC-1, Systems and Tuner Kits)	same	add'l 10-15+ hp	-	+\$200
OPTIONS	add "-D1SC" to part #	With D-1SC ProCharger (replacing P-1SC-1)	tuner kit only	specify	-	+\$250
	add "-D1X" to part #	With D-1X ProCharger (replacing P-1SC-1, Tuner Kits only)	tuner kit only	specify	-	+\$425
	add "-D" or "-1" or "-A"	With F-1D, F-1, F-1A ProCharger (replacing P-1SC-1)	tuner kit only	specify	-	+\$775
	add "-D" or "-1" or "-A"	With F-1D, F-1, F-1A ProCharger (replacing D-1SC)	tuner kit only	specify	-	+\$535
2011-20 F-150 (5.0, 6.2 4V) OPTIONS	add "-94" to part #	With F-1A-94 ProCharger (replacing P-1SC-1)	tuner kit only	specify	-	+\$1,100
	add "-RVR" or "-RVB"	Race Bypass Valve Upgrade (specify open or closed valve) - F150 Tuner Kit only	red or black	specify	-	+\$295
	add "-Race" to part #	Air-to-Air Race intercooler upgrade (from 3 core)	from 3 core	1100 hp max	3" tubing	+\$345
	add "-FA" to part #	Forward facing air inlet (rear facing is standard, 2011-14 5.0 only)	same	same	-	+\$119

2011-14 FORD F-150 (5.0, 6.2 4V) i-1 PROGRAMMABLE RATIO SYSTEMS

Year	Part Number	Description	Boost Options	HP Gain	Intercooler	Price
2011-14 (5.0)	1FV215-SCI	High Output Intercooled System with i-1 (5.0)	8-9 psi	60-70%	Race	\$8,699
2011-14 (6.2)	1FS215-SCI	High Output Intercooled System with i-1 (6.2)	8 psi	55%+	3 core	\$8,999

i-1 OPTIONS	add "-T" to part #	Touchscreen (at time of system purchase)	-	-	-	+\$395
	add "-B" to part #	Black finish (supercharger and bracket)	satin standard	-	-	+\$795
	add "-P" to part #	Polished finish (supercharger and bracket)	satin standard	-	-	+\$595
	add "-Race" to part #	Air-to-air race intercooler upgrade	from 3 core	1050 max hp	-	+\$795

2021 F150 SYSTEMS AND KITS - CALL FOR MORE INFORMATION

SPECIFICATIONS (2011-2021)

2020-21 FORD F-250/350 SUPER DUTY (7.3) SPECIFICATIONS

Year	Part Number	OEM HP/TQ Rating	HP Gain	Tube Diam	IC Mount	Drive System	Bypass System	Fuel System Upgrade	Fuel Inj. Supplied	Computer/Ignition Modifications	SC Warranty (in months)	CARB E.O.	Foot Notes
2020-21	1FZ211-SCI	430/474	50%+	3"	V	stk 6 rib	Bullet	not required	55 lb/hr	programmer supplied	12, 36 opt. (\$99)	-	EE1, EE3, EE4, EE6, EE9
2020-21	1FZ201-SCI	430/475	specify	3"	V	stk 6 rib	Bullet	not required	No	not supplied	12	-	EE1, EE6, EE9

2015-20 FORD F-150 (5.0 4V) SPECIFICATIONS

Year	Part Number	OEM HP/TQ Rating	HP Gain	Tube Diam	IC Mount	Drive System	Bypass System	Fuel System Upgrade	Fuel Inj. Supplied	Computer/Ignition Modifications	SC Warranty (in months)	CARB E.O.	Foot Notes
2018-20	1FY411-SCI	395/400	50-55%+	3"	V	add'l 8 rib	ProFlow	not required	not required	programmer supplied	12, 36 opt. (\$99)	D-365-24 (19)	EE1, EE2, EE3, EE4, EE5, EE6, EE7
2018-20	1FY401-SCI	395/400	specify	3"	V	add'l 8 rib	ProFlow	not required	No	not supplied	12	-	EE1, EE2, EE4, EE6, EE7
2018-20	1FY511-SCI	395/400	60-65%+	3"	V	add'l 8 rib	ProFlow	not required	not required	programmer supplied	12, 36 opt. (\$99)	D-365-24 (19)	EE1, EE2, EE3, EE4, EE5, EE6, EE7
2018-20	1FY501-SCI	395/400	specify	3"	V	add'l 8 rib	ProFlow	not required	No	not supplied	12	-	EE1, EE2, EE4, EE6, EE7
2015-17	1FY211-SCI	385/387	45-55%	3"	V	add'l 8 rib	ProFlow	not required	not required	programmer supplied	12, 36 opt. (\$99)	D-365-24	EE1, EE2, EE3, EE4, EE5, EE6, EE7
2015-17	1FY201-SCI	385/387	specify	3"	V	add'l 8 rib	ProFlow	not required	No	not supplied	12	-	EE1, EE2, EE4, EE6, EE7
2015-17	1FY311-SCI	385/387	60-70%	3"	V	add'l 8 rib	ProFlow	not required	52 lb/hr	programmer supplied	12, 36 opt. (\$99)	D-365-24	EE1, EE2, EE3, EE4, EE5, EE6, EE7
2015-17	1FY301-SCI	385/387	specify	3"	V	add'l 8 rib	ProFlow	not required	No	not supplied	12	-	EE1, EE2, EE4, EE6, EE7

2011-14 FORD F-150 (5.0, 6.2 4V) SPECIFICATIONS

Year	Part Number	OEM HP/TQ Rating	HP Gain	Tube Diam	IC Mount	Drive System	Bypass System	Fuel System Upgrade	Fuel Inj. Supplied	Computer/Ignition Modifications	SC Warranty (in months)	CARB E.O.	Foot Notes
2011-14 (5.0)	1FV211-SCI	360/380	45-55%	3"	V	add'l 8 rib	ProFlow	not required	not required	programmer supplied	12, 36 opt. (\$99)	D-365-24	EE1, EE2, EE4, EE5, EE6
2011-14 (5.0)	1FV201-SCI	360/380	specify	3"	V	add'l 8 rib	ProFlow	not required	No	not supplied	12	-	EE1, EE2, EE4, EE6
2011-14 (5.0)	1FV311-SCI	360/380	60-70%	3"	V	add'l 8 rib	ProFlow	not required	52 lb/hr	programmer supplied	12, 36 opt. (\$99)	D-365-24	EE1, EE2, EE4, EE5, EE6
2011-14 (5.0)	1FV301-SCI	360/380	specify	3"	V	add'l 8 rib	ProFlow	not required	No	not supplied	12	-	EE1, EE2, EE4, EE6
2011-14 (6.2)	1FS311-SCI-6.2	411/434	50%+	3"	V	stk 6 rib	ProFlow	not required	63 lb/hr	programmer supplied	12	-	EE1, EE2, EE3, EE4, EE5, EE6
2011-14 (6.2)	1FS301-SCI-6.2	411/434	specify	3"	V	stk 6 rib	ProFlow	not required	No	not supplied	12	-	EE1, EE2, EE6
2011-14 (6.2)	1FS211-SCI-6.2	411/434	55%	3"	V	add'l 8 rib	ProFlow	not required	63 lb/hr	programmer supplied	12, 36 opt. (\$99)	D-365-24	EE1, EE2, EE4, EE5, EE6
2011-14 (6.2)	1FS201-SCI-6.2	411/434	specify	3"	V	add'l 8 rib	ProFlow	not required	No	not supplied	12	-	EE1, EE2, EE6

2011-14 FORD F-150 (5.0, 6.2 4V) i-1 PROGRAMMABLE RATIO SPECIFICATIONS

Year	Part Number	OEM HP/TQ Rating	HP Gain	Tube Diam	IC Mount	Drive System	Bypass System	Fuel System Upgrade	Fuel Inj. Supplied	Computer/Ignition Modifications	SC Warranty (in months)	CARB E.O.	Foot Notes
2011-14 (5.0)	1FV215-SCI	360/380	45-55%	3"	V	add'l 8 rib	ProFlow	not required	52 lb/hr	programmer supplied	12, 36 opt. (\$149)	-	EE1, EE2, EE3, EE4, EE5, EE6, EE8
2011-14 (6.2)	1FS215-SCI	411/434	55%	3"	V	add'l 8 rib	ProFlow	not required	63 lb/hr	programmer supplied	12, 36 opt. (\$149)	-	EE1, EE2, EE3, EE4, EE5, EE6, EE8

FORD TRUCK/SUV FOOTNOTES (specific to above applications):

- EE1) Model year must be specified
- EE2) Specify 2WD or 4WD
- EE3) Due to variability among OEM computers, and the prevalence of custom modifications, dyno tuning may be required
- EE4) For Flex Fuel vehicles, gasoline-only tune provided, not E85
- EE5) ECM code required on hand-held programmer applications
- EE6) System ships in extra large box
- EE7) 2015+ models require aerodynamic grill shutter removal and/or trimming
- EE8) Two-part shipment, additional shipping charges may apply
- EE9) Does not work with dual alternator/battery



2017-20 FORD F-150 SVT RAPTOR (3.5L ECOBOOST) INTERCOOLER KITS

Year	Part Number	Description	Boost Options	HP Gain	Intercooler	Price
2017-20	2FSIC-001	Intercooler Upgrade Kit from OEM	tuner kit only	-	Stage II	\$1,299

2010-14 FORD F-150 SVT RAPTOR (6.2, 5.4 3V) SYSTEMS AND KITS

Year	Part Number	Description	Boost Options	HP Gain	Intercooler	Price
2010-14 (6.2)	1FS311-SCI-6.2	High Output Intercooled System with D-1SC	7-8 psi	50%+	3 core	\$7,149
2010-14 (6.2)	1FS301-SCI-6.2	High Output Intercooled Tuner Kit with D-1SC	specify	specify	3 core	\$6,299
2010-14 (6.2)	1FS211-SCI-6.2	Stage II Intercooled System with P-1SC-1 (dedicated 8-rib drive)	7-8 psi	50%+	3 core	\$7,349
2010-14 (6.2)	1FS201-SCI-6.2	Stage II Intercooled Tuner Kit with P-1SC-1 (dedicated 8-rib drive)	specify	specify	3 core	\$6,499
2010 (5.4)	1FS211-SCI-5.4	High Output Intercooled System with P-1SC-1	8-9 psi	60%+	3 core	\$6,749
2010 (5.4)	1FS201-SCI-5.4	High Output Intercooled Tuner Kit with P-1SC-1	specify	specify	3 core	\$6,199

2010-14 RAPTOR (6.2, 5.4) OPTIONS	add "-B" or "-P" to part #	Black or Polished finish for ProCharger (P-series or D-series)	satin standard	-	-	+\$295
	add "-BB" or "-PB" to part #	Black or Polished finish for supercharger bracket	satin standard	-	-	+\$250
	add "-H" to part #	Helical gerset for noise reduction (P-1SC-1, P-1X, D-1SC, D-1X)	same	same	-	+\$100
	add "-P1X" to part #	With P-1X ProCharger (replacing P-1SC-1, Systems and Tuner Kits)	same	add'l 10-15+ hp	-	+\$200
	add "-D1SC" to part #	With D-1SC ProCharger (replacing P-1SC-1)	tuner kit only	specify	-	+\$250
	add "-D1X" to part #	With D-1X ProCharger (replacing P-1SC-1, Tuner Kits only)	tuner kit only	specify	-	+\$425
	add "-Race" to part #	Air-to-air race intercooler upgrade	from 3 core	1050 hp max	-	+\$345

2010-14 FORD F-150 SVT RAPTOR (6.2) i-1 PROGRAMMABLE RATIO SYSTEMS

Year	Part Number	Description	Boost Options	HP Gain	Intercooler	Price
2010-14 (6.2)	1FS215-SCI	High Output Intercooled System with i-1	8 psi	55%+	3 core	\$8,799

i-1 OPTIONS	add "-T" to part #	Touchscreen (at time of system purchase)	-	-	-	+\$395
	add "-B" to part #	Black finish (supercharger and bracket)	satin standard	-	-	+\$795
	add "-P" to part #	Polished finish (supercharger and bracket)	satin standard	-	-	+\$595
	add "-Race" to part #	Air-to-air race intercooler upgrade	from 3 core	1050 hp max	-	+\$795

2004-10 FORD F-150 AND 2007-14 EXPEDITION (5.4 3V) SYSTEMS AND KITS

Year	Part Number	Description	Boost Options	HP Gain	Intercooler	Price
2009-10	1FN211-SCI	High Output Intercooled System with P-1SC-1 (F-150)	8-9 psi	60-65%	2 core	\$6,399
2009-10	1FN201-SCI	High Output Intercooled Tuner Kit with P-1SC-1 (F-150)	specify	specify	2 core	\$5,849
2004-08	1FN211-SCI	High Output Intercooled System with P-1SC-1 (F-150)	8-9 psi	60-65%	2 core	\$6,299
2004-08	1FN201-SCI	High Output Intercooled Tuner Kit with P-1SC-1 (F-150)	specify	specify	2 core	\$5,749
2007-08	1FN211-SCI	High Output Intercooled System with P-1SC-1 (Expedition)	8-9 psi	60-65%	2 core	\$6,399
2007-14	1FN201-SCI	High Output Intercooled Tuner Kit with P-1SC-1 (Expedition)	specify	specify	2 core	\$5,849

1997-03 FORD F-150 AND 1997-02 EXPEDITION (5.4, 4.6 2V) SYSTEMS AND KITS

Year	Part Number	Description	Boost Options	HP Gain	Intercooler	Price
1997-03 (5.4)	1FG211-SCI	High Output Intercooled System with P-1SC (F150/Expedition*)	8-9 psi	60-65%	2 or 3 core, see below	\$5,999
1997-03 (5.4)	1FG201-SCI	High Output Intercooled Tuner Kit with P-1SC (F150/Expedition*)	specify	specify	2 or 3 core, see below	\$5,699
1997-03 (4.6)	1FH211-SCI	High Output Intercooled System with P-1SC (F150/Expedition*)	8-9 psi	60-65%	2 or 3 core, see below	\$5,999
1997-03 (4.6)	1FH201-SCI	High Output Intercooled Tuner Kit with P-1SC (F150/Expedition*)	specify	specify	2 or 3 core, see below	\$5,699

1997-2010 F-150 & EXPEDITION	add "-P" to part #	Polished finish for ProCharger (P-series or D-series)	satin standard	-	-	+\$295
	add "-H" to part #	Helical gerset for noise reduction (P-1SC, D-1SC)	same	same	-	+\$100
	add "-D1SC" to part #	With D-1SC ProCharger (replacing P-1SC)	specify	specify	-	+\$480
	add "-3C" to part #	3 core intercooler system upgrade (2004+ only)	from 2 core	825 hp max	3" tubing	+\$345

* Excludes 2003 Expedition

SPECIFICATIONS (1997-2010 F-150 & 2010-20 RAPTOR)

2017-20 FORD F-150 SVT RAPTOR (3.5L ECOBOOST) INTERCOOLER KITS

Year	Part Number	OEM HP/TQ Rating	HP Gain	Tube Diam	IC Mount	Drive System	Bypass System	Fuel System Upgrade	Fuel Inj. Supplied	Computer/Ignition Modifications	SC Warranty (in months)	CARB E.O.	Foot Notes
2017-20	2FSIC-001	450/510	-	3.5"	V	-	-	-	-	-	-	-	FF10

2010-14 FORD F-150 SVT RAPTOR (6.2, 5.4 3V) SPECIFICATIONS

Year	Part Number	OEM HP/TQ Rating	HP Gain	Tube Diam	IC Mount	Drive System	Bypass System	Fuel System Upgrade	Fuel Inj. Supplied	Computer/Ignition Modifications	SC Warranty (in months)	CARB E.O.	Foot Notes
2010-14 (6.2)	1FS311-SCI-6.2	411/434	50%+	3"	V	stk 6 rib	ProFlow	not required	63 lb/hr	programmer sup.	12	-	FF1, FF2, FF3, FF5, FF6
2010-14 (6.2)	1FS301-SCI-6.2	411/434	specify	3"	V	stk 6 rib	ProFlow	not required	No	not supplied	12	-	FF1, FF2, FF6
2010-14 (6.2)	1FS211-SCI-6.2	411/434	50%+	3"	V	add'l 8 rib	ProFlow	not required	63 lb/hr	programmer sup.	12, 36 opt. (\$99)	D-365-8	FF1, FF6
2010-14 (6.2)	1FS201-SCI-6.2	411/434	specify	3"	V	add'l 8 rib	ProFlow	not required	No	not supplied	12	-	FF1, FF6
2010 (5.4)	1FS211-SCI-5.4	320/390	60%	3"	V	stk 6 rib	ProFlow	not required	39.5 lb/hr	programmer sup.	12, 36 opt. (\$99)	D-365-8	FF1, FF2, FF3, FF6
2010 (5.4)	1FS201-SCI-5.4	320/390	specify	3"	V	stk 6 rib	ProFlow	not required	No	not supplied	12	-	FF1, FF2, FF6

2010-14 FORD F-150 SVT RAPTOR (6.2) i-1 PROGRAMMABLE RATIO SPECIFICATIONS

Year	Part Number	OEM HP/TQ Rating	HP Gain	Tube Diam	IC Mount	Drive System	Bypass System	Fuel System Upgrade	Fuel Inj. Supplied	Computer/Ignition Modifications	SC Warranty (in months)	CARB E.O.	Foot Notes
2010-14	1FS215-SCI	411/434	55%+	3"	V	add'l 8 rib	ProFlow	not required	63 lb/hr	programmer sup.	12, 36 opt. (\$149)	-	FF1, FF5, FF6, FF8

2004-10 FORD F-150 & 2007-14 EXPEDITION (5.4 3V) SPECIFICATIONS

Year	Part Number	OEM HP/TQ Rating	HP Gain	Tube Diam	IC Mount	Drive System	Bypass System	Fuel System Upgrade	Fuel Inj. Supplied	Computer/Ignition Modifications	SC Warranty (in months)	CARB E.O.	Foot Notes
2009-10	1FN211-SCI	310/365	60-65%	3"	V	stk 6 rib	ProFlow	not required	not req.	programmer sup.	12, 36 opt. (\$99)	D-365-8	FF1, FF2, FF6, FF7, FF8
2009-10	1FN201-SCI	310/365	specify	3"	V	stk 6 rib	ProFlow	not required	No	not supplied	12	-	FF1, FF2, FF8
2004-08	1FN211-SCI	300/365	60-65%	3"	V	stk 6 rib	ProFlow	not required	39.5 lb/hr	programmer sup.	12, 36 opt. (\$99)	D-365-8	FF1, FF2, FF7
2004-08	1FN201-SCI	300/365	specify	3"	V	stk 6 rib	ProFlow	not required	No	not supplied	12	-	FF1, FF2
2007-08	1FN211-SCI	300/365	60-65%	3"	V	stk 6 rib	ProFlow	not required	39.5 lb/hr	programmer sup.	12, 36 opt. (\$99)	D-365-8	FF1, FF2, FF7
2007-14	1FN201-SCI	300/365	specify	3"	V	stk 6 rib	ProFlow	not required	No	not supplied	12	-	FF1, FF2

1997-03 FORD F-150 & 1997-02 EXPEDITION (5.4, 4.6 2V) SPECIFICATIONS

Year	Part Number	OEM HP/TQ Rating	HP Gain	Tube Diam	IC Mount	Drive System	Bypass System	Fuel System Upgrade	Fuel Inj. Supplied	Computer/Ignition Modifications	SC Warranty (in months)	CARB E.O.	Foot Notes
1997-03 (5.4)	1FG211-SCI	260/345	60-65%	3"	V	add'l 6 rib	ProFlow	ProPump, FMU	not req.	not required	12, 36 opt. (\$99)	D-365-2/8	FF1, FF2, FF3, FF4, FF9
1997-03 (5.4)	1FG201-SCI	260/345	specify	3"	V	add'l 6 rib	ProFlow	not supplied	not req.	not required	12	-	FF1, FF2, FF3, FF4, FF9
1997-03 (4.6)	1FH211-SCI	210/290	60-65%	3"	V	add'l 6 rib	ProFlow	ProPump, FMU	not req.	not required	12, 36 opt. (\$99)	D-365-8 (02-03)	FF1, FF2, FF3, FF4, FF9
1997-03 (4.6)	1FH201-SCI	210/290	specify	3"	V	add'l 6 rib	ProFlow	not supplied	not req.	not required	12	-	FF1, FF2, FF3, FF4, FF9

FORD TRUCK/SUV FOOTNOTES (specific to above applications):

- FF1) Model year must be specified
- FF2) Specify 2WD or 4WD, Truck or SUV
- FF3) Fits Light Duty F-250 applications with minor modifications
- FF4) 1997-98 Ford F-150/Expedition systems/kits include 2 core intercooler, 1999-03 include 3 core intercooler
- FF5) Due to variability among OEM computers, and prevalence of custom mods, dyno tuning may be required

- FF6) For Flex Fuel vehicles, gasoline-only tune provided, not E85
- FF7) ECM code required on hand-held programmer applications
- FF8) System ships in extra large box
- FF9) Special order kit: order form and non-refundable deposit required at time of order—may require additional lead time for processing
- FF10) Requires aerodynamic grill shutter removal and/or trimming



2018-21 DODGE DURANGO 5.7 SYSTEMS & KITS COMING SOON

2018-21 DODGE DURANGO SRT (6.4) SYSTEMS & KITS

Year	Part Number	Description	Boost Options	HP Gain	Intercooler	Price
2018-21	1DL215-SCI	High Output Intercooled System with P-1SC-1	7 psi	215+	3 core	\$7,899
2018-21	1DL205-SCI	High Output Intercooled Tuner Kit with P-1SC-1	specify	specify	3 core	\$6,899
2018-21 DODGE DURANGO SRT (6.4) OPTIONS	add "-B" or "-P" to part #	Black or Polished finish for ProCharger (P-series or D-series)	satin standard	-	-	+\$295
	add "-B" or "-P" to part #	Black or Polished finish for ProCharger (F-series, 9" housing)	satin standard	-	-	+\$325
	add "-BB" or "-PB" to part #	Black or Polished finish for supercharger bracket	satin standard	-	-	+\$250
	add "-H" to part #	Helical gearset for noise reduction (P-1SC-1, P-1X, D-1SC, D-1X)	same	same	-	+\$100
	add "-P1X" to part #	With P-1X ProCharger (replacing P-1SC-1, System and Tuner Kit)	same	add'l 10-15+ hp	-	+\$200
	add "-D1SC" to part #	With D-1SC ProCharger (replacing P-1SC-1)	tuner kit only	specify	-	+\$250
	add "-D1X" to part #	With D-1X ProCharger (replacing P-1SC-1, Tuner Kit only)	tuner kit only	specify	-	+\$425
add "-D" or "-1" or "-A"	With F-1, F-1A, F-1D ProCharger (replacing P-1SC-1)	tuner kit only	specify	-	+\$775	
add "-RVR" or "RVB"	Race Bypass Valve Upgrade (specify open or closed valve)	red or black	specify	-	+\$295	

2014-21 RAM 2500/3500 AND POWER WAGON (6.4) SYSTEMS & KITS

Year	Part Number	Description	Boost Options	HP Gain	Intercooler	Price
2019-21	1DN312-SCI	High Output Intercooled Systems with D-1SC	6 psi	130+	3 core	\$7,499
2019-21	1DN302-SCI	High Output Intercooled Tuner Kit with D-1SC	specify	specify	3 core	\$6,599
2014-18	1DN212-SCI	High Output Intercooled Systems with D-1SC	6 psi	130+	3 core	\$7,399
2014-18	1DN202-SCI	High Output Intercooled Tuner Kit with D-1SC	specify	specify	3 core	\$6,499
2014-21 RAM (6.4) OPTIONS	add "-B" or "-P" to part #	Black or Polished finish for ProCharger (P-series)	satin standard	-	-	+\$295
	add "-BB" or "-PB" to part #	Black or Polished finish for supercharger bracket	satin standard	-	-	+\$250
	add "-H" to part #	Helical gearset for noise reduction (D-1SC)	same	same	-	+\$100
	add "-PW" to part #	Power Wagon w/ Factory Winch (2014-21 only, 19+ Standard)	same	same	-	+\$150

2011-21 RAM 1500 CLASSIC / 2019-21 RAM 1500 (5.7) / eTorque (5.7) SYSTEMS AND KITS

Year	Part Number	Description	Boost Options	HP Gain	Intercooler	Price
2019-21	1DP314-SCI	High Output Intercooled System with D-1SC	7 psi	140+	3 core	\$6,999
2019-21	1DP304-SCI	High Output Intercooled Tuner Kit with D-1SC	specify	specify	3 core	\$6,399
2019-21	1DP315-SCI	Stage II Intercooled System with P-1SC-1 (dedicated 8-rib drive)	7 psi	140+	3 core	\$7,599
2019-21	1DP305-SCI	Stage II Intercooled Tuner Kit with P-1SC-1 (dedicated 8-rib drive)	specify	specify	3 core	\$6,999
2019-21	1DP415-SCI	Stage II Intercooled System with P-1SC-1 (eTorque)	7 psi	140+	3 core	\$7,599
2019-21	1DP405-SCI	Stage II Intercooled Tuner Kit with P-1SC-1 (eTorque)	specify	specify	3 core	\$6,999
2011-21	1DH314-SCI	High Output Intercooled System with D-1SC (CLASSIC)	7 psi	140+	3 core	\$6,999
2011-21	1DH304-SCI	High Output Intercooled Tuner Kit with D-1SC (CLASSIC)	specify	specify	3 core	\$6,399
2011-21	1DH315-SCI	Stage II Intercooled System with P-1SC-1 (dedicated 8-rib drive) (CLASSIC)	7 psi	140+	3 core	\$7,599
2011-21	1DH305-SCI	Stage II Intercooled Tuner Kit with P-1SC-1 (dedicated 8-rib drive) (CLASSIC)	specify	specify	3 core	\$6,999
2011-21 RAM (5.7) OPTIONS	add "-B" or "-P" to part #	Black or Polished finish for ProCharger (P-series or D-series)	satin standard	-	-	+\$295
	add "-B" or "-P" to part #	Black or Polished finish for ProCharger (F-series 9"-9.75" housing)	satin standard	-	-	+\$325
	add "-BB" or "-PB" to part #	Black or Polished finish for supercharger bracket	satin standard	-	-	+\$250
5.7 HO ONLY	add "-H" to part #	Helical gearset for noise reduction (P-1SC-1, P-1X, D-1SC, D-1X)	same	same	-	+\$100
	add "-D1X" to part #	With D-1X ProCharger (replacing D-1SC)	tuner kit only	specify	-	+\$175
	add "-P1X" to part #	With P-1X ProCharger (replacing P-1SC-1, Systems and Tuner Kits)	same	add'l 10-15+ hp	-	+\$200
	add "-D1SC" to part #	With D-1SC ProCharger (replacing P-1SC-1)	tuner kit only	specify	-	+\$250
	add "-D1X" to part #	With D-1X ProCharger (replacing P-1SC-1)	tuner kit only	specify	-	+\$425
	add "-D" or "-1" or "-A"	With F-1D, F-1, F-1A ProCharger (replacing P-1SC-1)	tuner kit only	specify	-	+\$775
	add "-94" or "-C" or "-R" to part #	With F-1A-94, F-1C, F-1R ProCharger (replacing P-1SC-1)	tuner kit only	specify	-	+\$1,100
add "-RVR" or "RVB"	Race Bypass Valve Upgrade (specify open or closed valve)	red or black	specify	-	+\$295	
add "-ATIPP" to part #	ATI Performance Products Balancer Upgrade	-	-	-	+\$475	

SPECIFICATIONS (2018-21 DURANGO & 2011-21 RAM)

2018-21 DODGE DURANGO SRT (6.4) SPECIFICATIONS

Year	Part Number	OEM HP/TQ Rating	HP Gain	Tube Diam	IC Mount	Drive System	Bypass System	Fuel System Upgrade	Fuel Inj. Supplied	Comp./Ignition Modifications	SC Warranty (in months)	CARB E.O.	Foot Notes
2018-21	1DL215-SCI	475/470	215+	3"	V	stk 6 rib	ProFlow	MAP sensor	52 lb/hr	programmer sup.	12, 36 opt. (\$99)	D-365-26	GG1, GG3, GG6
2018-21	1DL205-SCI	475/470	specify	3"	V	stk 6 rib	ProFlow	not supplied	No	not supplied	12	-	GG1

2014-21 RAM 2500/3500 AND POWER WAGON (6.4) SPECIFICATIONS

Year	Part Number	OEM HP/TQ Rating	HP Gain	Tube Diam	IC Mount	Drive System	Bypass System	Fuel System Upgrade	Fuel Inj. Supplied	Computer/Ignition Modifications	SC Warranty (in months)	CARB E.O.	Foot Notes
2019-21	1DN312-SCI	410/429	130+	3"	V	stk 6 rib	ProFlow	not required	52 lb/hr	programmer sup.	12	-	GG1, GG2, GG3, GG6
2019-21	1DN302-SCI	410/429	specify	3"	V	stk 6 rib	ProFlow	-	No	not supplied	12	-	GG1, GG2, GG6
2014-18	1DN212-SCI	410/429	130+	3"	V	stk 6 rib	ProFlow	not required	52 lb/hr	programmer sup.	12	-	GG1, GG2, GG3, GG6
2014-18	1DN202-SCI	410/429	specify	3"	V	stk 6 rib	ProFlow	-	No	not supplied	12	-	GG1, GG2, GG6

2011-21 RAM 1500 CLASSIC / 2019-21 RAM 1500 (5.7) / eTorque (5.7) SPECIFICATIONS

Year	Part Number	OEM HP/TQ Rating	HP Gain	Tube Diam	IC Mount	Drive System	Bypass System	Fuel System Upgrade	Fuel Inj. Supplied	Computer/Ignition Supercharger Warranty Modifications (in months)	CARB E.O.	Foot Notes	
2019-21	1DP314-SCI	390/407	140+	3"	V	stk 6 rib	ProFlow	not required	39.5 lb/hr	programmer sup.	12	GG1, GG2, GG3, GG4, GG5, GG6	
2019-21	1DP304-SCI	390/407	specify	3"	V	stk 6 rib	ProFlow	-	No	not supplied	12	GG1, GG2, GG4, GG5	
2019-21	1DP315-SCI	390/407	140+	3"	V	add'l 8 rib	ProFlow	not required	39.5 lb/hr	programmer sup.	12, 36 opt. (\$99)	-	GG1, GG2, GG3, GG4, GG5, GG6, GG7
2019-21	1DP305-SCI	390/407	specify	3"	V	add'l 8 rib	ProFlow	-	No	not supplied	12	GG1, GG2, GG4, GG5, GG7	
2019-21	1DP415-SCI	390/407	140+	3"	V	add'l 8 rib	ProFlow	not required	39.5 lb/hr	programmer sup.	12	GG1, GG2, GG3, GG4, GG5, GG6	
2019-21	1DP405-SCI	390/407	specify	3"	V	add'l 8 rib	ProFlow	-	No	not supplied	12	GG1, GG2, GG4, GG5	
2011-21	1DH314-SCI	390/407	140+	3"	V	stk 6 rib	ProFlow	not required	39.5 lb/hr	programmer sup.	12	GG1, GG2, GG3, GG4, GG5, GG6	
2011-21	1DH304-SCI	390/407	specify	3"	V	stk 6 rib	ProFlow	-	No	not supplied	12	GG1, GG2, GG4, GG5	
2009-21	1DH315-SCI	390/407	130+/140+	3"	V	add'l 8 rib	ProFlow	not required	39.5 lb/hr	programmer sup.	12, 36 opt. (\$99)	D-365-18 (15-18)	GG1, GG2, GG4, GG5, GG6, GG7
2009-21	1DH305-SCI	390/407	specify	3"	V	add'l 8 rib	ProFlow	-	No	not supplied	12	GG1, GG2, GG4, GG5, GG7	

DODGE TRUCK/SUV FOOTNOTES (specific to above applications):

- GG1) Model year must be specified
- GG2) Specify 2WD or 4WD
- GG3) Due to variability among OEM computers, and the prevalence of custom modifications, dyno tuning may be required
- GG4) Systems are for 1500 Series only; modification and custom tuning required for 2011-13 2500 Series vehicles and above (2500, 3500, Mega Cab, and Power Wagon) (Tuner Kits only)
- GG5) 2013+ models require aerodynamic-shutter removal
- GG6) 2015+ vehicles require ECM unlock (call for details)
- GG7) Requires ATI Performance Products balancer #918453 (not included - specify hardened hub)



2009-10 RAM (5.7) SYSTEMS AND KITS

Year	Part Number	Description	Boost Options	HP Gain	Intercooler	Price
2009-10	1DH214-SCI	High Output Intercooled System with P-1SC-1	7 psi	130+	3 core	\$6,899
2009-10	1DH204-SCI	High Output Intercooled Tuner Kit with P-1SC-1	specify	specify	3 core	\$6,199
2009-10	1DH315-SCI	Stage II Intercooled System with P-1SC-1 (dedicated 8-rib drive)	7 psi	130+	3 core	\$7,499
2009-10	1DH305-SCI	Stage II Intercooled Tuner Kit with P-1SC-1 (dedicated 8-rib drive)	specify	specify	3 core	\$6,799

2004-08 DODGE RAM (5.7) SYSTEMS AND KITS

Year	Part Number	Description	Boost Options	HP Gain	Intercooler	Price
2004-08	1DC214-SCI	High Output Intercooled System with P-1SC-1	6 psi	45-50%	3 core high mount	\$6,899
2004-08	1DC204-SCI	High Output Intercooled Tuner Kit with P-1SC-1	tuner kit only	specify	3 core high mount	\$5,948

2004-10 RAM (5.7) OPTIONS	add "-P" to part #	Polished finish for ProCharger (P-series or D-series)	satin standard	-	-	+\$295
	add "-PB" to part #	Polished finish for supercharger bracket	satin standard	-	-	+\$300
	add "-H" to part #	Helical gearset for noise reduction (P-1SC-1, D-1SC)	same	same	-	+\$100
	add "-D1SC" to part #	With D-1SC ProCharger (replacing P-1SC-1)	tuner kit only	specify	-	+\$250
	add "-LM" to part #	Low mount intercooler (replacing 3 core high mount, 2006-08 only)	same	same	same	+\$100
	add "-ATIPP" to part #	ATI Performance Products Balancer Upgrade (2009-10 Stage II only)	-	-	-	+\$475

1996-01 DODGE RAM (5.9, 5.2) TUNER KIT

Year	Part Number	Description	Boost Options	Est. HP Gain	Intercooler	Price
1996-01	1DA202-SCI	High Output Intercooled Tuner Kit with P-1SC	8-9 psi	55-60%	2 core	\$5,899

1997-01 DODGE DAKOTA/DURANGO (5.9, 5.2) TUNER KIT

Year	Part Number	Description	Boost Options	Est. HP Gain	Intercooler	Price
1997-01	1DB202-SCI	High Output Intercooled Tuner Kit with P-1SC	8-9 psi	55-60%	2 core	\$5,899

1996-01 RAM, DAKOTA, DURANGO	add "-P" to part #	Polished finish for ProCharger (P-series or D-series)	satin standard	-	-	+\$295
	add "-H" to part #	Helical gearset for noise reduction (P-1SC, D-1SC)	same	same	-	+\$100
	add "-D1SC" to part #	With D-1SC ProCharger (replacing P-1SC)	tuner kit only	specify	-	+\$470
	add "-3C" to part #	3 core intercooler system upgrade (Ram only)	from 2 core	825 hp max	3" tubing	+\$345

SPECIFICATIONS (1997-2001 DURANGO & 1996-2010 RAM)

2009-10 RAM (5.7) SPECIFICATIONS

Year	Part Number	OEM HP/TQ Rating	HP Gain	Tube Diam	IC Mount	Drive System	Bypass System	Fuel System Upgrade	Fuel Inj. Supplied	Computer/Ignition Modifications	Supercharger Warranty (in months)	CARB E.O.	Foot Notes
2009-10	1DH214-SCI	390/407	130+	3"	V	stk 6 rib	ProFlow	not required	39.5 lb/hr	programmer sup.	12, 36 opt. (\$99)	D-365-9	HH1, HH2, HH6
2009-10	1DH204-SCI	390/407	specify	3"	V	stk 6 rib	ProFlow	-	No	not supplied	12	-	HH1, HH2, HH6
2009-10	1DH315-SCI	390/407	130+	3"	V	add'l 8 rib	ProFlow	not required	39.5 lb/hr	programmer sup.	12, 36 opt. (\$99)	D-365-9	HH1, HH2, HH6
2009-10	1DH305-SCI	390/407	specify	3"	V	add'l 8 rib	ProFlow	-	No	not supplied	12	-	HH1, HH2, HH6

2004-08 DODGE RAM (5.7) SPECIFICATIONS

Year	Part Number	OEM HP/TQ Rating	HP Gain	Tube Diam	IC Mount	Drive System	Bypass System	Fuel System Upgrade	Fuel Inj. Supplied	Computer/Ignition Modifications	Supercharger Warranty (in months)	CARB E.O.	Foot Notes
2004-08	1DC214-SCI	345/375	45-50%	3"	V	stk 7 rib	ProFlow	not required	39.5 lb/hr	programmer sup.	12, 36 opt. (\$99)	D-365-7	HH1, HH2, HH4, HH6, HH7
2004-08	1DC204-SCI	345/375	specify	3"	V	stk 7 rib	ProFlow	not supplied	No	not supplied	12	-	HH1, HH2, HH4, HH6, HH7

1996-01 DODGE RAM (5.9, 5.2) SPECIFICATIONS

Year	Part Number	OEM HP/TQ Rating	Est. HP Gain	Tube Diam	IC Mount	Drive System	Bypass System	Fuel System Upgrade	Fuel Inj. Supplied	Computer/Ignition Modifications	Supercharger Warranty (in months)	CARB E.O.	Foot Notes
1996-01	1DA202-SCI	250/335	55-60%	3"	H	stk 7 rib	ProFlow	not supplied	not required	not required	12	-	HH1, HH2, HH5, HH6, HH7

1997-01 DODGE DAKOTA/DURANGO (5.9, 5.2) SPECIFICATIONS

Year	Part Number	OEM HP/TQ Rating	Est. HP Gain	Tube Diam	IC Mount	Drive System	Bypass System	Fuel System Upgrade	Fuel Inj. Supplied	Computer/Ignition Modifications	Supercharger Warranty (in months)	CARB E.O.	Foot Notes
1997-01	1DB202-SCI	250/335	55-60%	3"	H	stk 7 rib	ProFlow	not supplied	not required	not required	12	-	HH1, HH2, HH5, HH6, HH7

DODGE TRUCK/SUV FOOTNOTES (specific to above applications):

- HH1) Model year must be specified
- HH2) Specify 2WD or 4WD
- HH3) Due to variability among OEM computers, and the prevalence of custom modifications, dyno tuning may be required
- HH4) Low mount intercooler option available for 2006-08 model years only
- HH5) MSD boost timing master may be required (sold separately by others)
- HH6) For 1500 Series only; modification and custom tuning required for 2500 Series vehicles and above (2500, 3500, Mega Cab, and Power Wagon) (Tuner Kits only)
- HH7) Special order kit: order form and non-refundable deposit required at time of order—may require additional lead time for processing



2012-20 JEEP GRAND CHEROKEE (6.4) SYSTEMS & KITS

Year	Part Number	Description	Boost Options	HP Gain	Intercooler	Price
2012-20	1DL214-SCI	High Output Intercooled System with P-1SC-1	7 psi	215+	3 core	\$7,999
2012-20	1DL204-SCI	High Output Intercooled Tuner Kit with P-1SC-1	specify	specify	3 core	\$6,999

2011-20 JEEP GRAND CHEROKEE (5.7) SYSTEMS AND KITS

Year	Part Number	Description	Boost Options	HP Gain	Intercooler	Price
2011-20	1DM214-SCI	High Output Intercooled System with P-1SC-1	7 psi	160+	3 core	\$7,399
2011-20	1DM204-SCI	High Output Intercooled Tuner Kit with P-1SC-1	specify	specify	3 core	\$6,399

2006-10 JEEP GRAND CHEROKEE SRT8 (6.1) SYSTEMS AND KITS

Year	Part Number	Description	Boost Options	HP Gain	Intercooler	Price
2006-10	1DJ214-SCI	High Output Intercooled System with P-1SC-1	7 psi	160+	3 core	\$7,199
2006-10	1DJ204-SCI	High Output Intercooled Tuner Kit with P-1SC-1	specify	specify	3 core	\$5,999
2006-10	1DJ314-SCI	Stage II Intercooled System with P-1SC-1 (dedicated 8-rib)	7 psi	160+	3 core	\$7,699
2006-10	1DJ304-SCI	Stage II Intercooled Tuner Kit with P-1SC-1 (dedicated 8-rib)	specify	specify	3 core	\$6,499

2006-20 GRAND CHEROKEE (6.4, 5.7, 6.1) OPTIONS	add "-B" or "-P" to part #	Black or Polished finish for ProCharger (P-series or D-series)	satin standard	-	-	+\$295
	add "-B" or "-P" to part #	Black or Polished finish for ProCharger (F-series, 9" housing)	satin standard	-	-	+\$325
	add "-BB" or "-PB" to part #	Black or Polished finish for supercharger bracket	satin standard	-	-	+\$250
	add "-H" to part #	Helical gerset for noise reduction (P-1SC-1, P-1X, D-1SC, D-1X)	same	same	-	+\$100
	add "-P1X" to part #	With P-1X ProCharger (replacing P-1SC-1, System and Tuner Kit)	same	add'l 10-15+ hp	-	+\$200
	add "-D1SC" to part #	With D-1SC ProCharger (replacing P-1SC-1)	tuner kit only	specify	-	+\$250
	add "-D1X" to part #	With D-1X ProCharger (replacing P-1SC-1, Tuner Kit only)	tuner kit only	specify	-	+\$425
	add "-D" or "-1" or "-A"	With F-1, F-1A, F-1D ProCharger (replacing P-1SC-1)	tuner kit only	specify	-	+\$775
	add "-94" to part #	With F-1A-94 ProCharger (replacing P-1SC-1)	tuner kit only	specify	-	+\$1,100
	add "-RVR" or "-RVB"	Race Bypass Valve Upgrade (specify open or closed valve)	red or black	specify	-	+\$295
add "-Race" to part #	Air-to-Air Race intercooler upgrade	from 3 core	1100 hp max	-	+\$345	

2020-21 JEEP GLADIATOR JT (3.6) SYSTEMS AND KITS

Year	Part Number	Description	Boost Options	HP Gain	Intercooler	Price
2020-21	1JT214-SCI	High Output Intercooled System with P-1SC-1	7 psi	40-45%+	custom JL	\$6,699
2020-21	1JT204-SCI	High Output Intercooled Tuner Kit with P-1SC-1	specify	specify	custom JL	\$5,899

2018-21 JEEP WRANGLER JL (3.6) SYSTEMS AND KITS

Year	Part Number	Description	Boost Options	HP Gain	Intercooler	Price
2018-21	1JL214-SCI	High Output Intercooled System with P-1SC-1	7 psi	40-45%+	custom JL	\$6,699
2018-21	1JL204-SCI	High Output Intercooled Tuner Kit with P-1SC-1	specify	specify	custom JL	\$5,899

2012-18 JEEP WRANGLER JK (3.6) SYSTEMS AND KITS

Year	Part Number	Description	Boost Options	HP Gain	Intercooler	Price
2012-18	1JK214-SCI	High Output Intercooled System with P-1SC-1	7 psi	50%+	custom JK	\$6,699
2012-18	1JK204-SCI	High Output Intercooled Tuner Kit with P-1SC-1	specify	specify	custom JK	\$5,999

2012-21 WRANGLER JL / JK (3.6) OPTIONS	add "-B" or "-P" to part #	Black or Polished finish for ProCharger (P-series or D-series)	satin standard	-	-	+\$295
	add "-BB" or "-PB" to part #	Black or Polished finish for supercharger bracket	satin standard	-	-	+\$300
	add "-BI" to part #	Black finish for Intercooler	satin standard	-	-	+\$125
	add "-H" to part #	Helical gerset for noise reduction (P-1SC-1, D-1SC)	same	same	-	+\$100
	add "-D1SC" to part #	With D-1SC ProCharger (replacing P-1SC-1)	tuner kit only	specify	-	+\$250

CALL FOR MORE INFO ON: 2021 392 Rubicon Wrangler / 2021 Grand Cherokee / 2021 Grand Wagoneer

SPECIFICATIONS (WRANGLER / GLADIATOR / GRAND CHEROKEE)

2012-20 JEEP GRAND CHEROKEE SRT (6.4) SPECIFICATIONS

Year	Part Number	OEM HP/TQ Rating	HP Gain	Tube Diam	IC Mount	Drive System	Bypass System	Fuel System Upgrade	Fuel Inj. Supplied	Comp./Ignition Modifications	SC Warranty (in months)	CARB E.O.	Foot Notes
2012-20	1DL214-SCI	475/470	215+	3"	V	stk 6 rib	ProFlow	MAP sensor	52 lb/hr	programmer sup.	12, 36 opt. (\$99)	D-365-26 (12-20)	II1, II4, II6, II8
2012-20	1DL204-SCI	475/470	specify	3"	V	stk 6 rib	ProFlow	not supplied	No	not supplied	12	-	II1, II8

2011-20 JEEP GRAND CHEROKEE (5.7) SPECIFICATIONS

Year	Part Number	OEM HP/TQ Rating	HP Gain	Tube Diam	IC Mount	Drive System	Bypass System	Fuel System Upgrade	Fuel Inj. Supplied	Comp./Ignition Modifications	SC Warranty (in months)	CARB E.O.	Foot Notes
2011-20	1DM214-SCI	360/390	160+	3"	V	stk 6 rib	ProFlow	MAP sensor	39.5 lb/hr	programmer sup.	12, 36 opt. (\$99)	D-365-22 (11-19)	II1, II4, II6, II8
2011-20	1DM204-SCI	360/390	specify	3"	V	stk 6 rib	ProFlow	not supplied	No	not supplied	12	-	II1, II8

2006-10 JEEP GRAND CHEROKEE SRT8 (6.1) SPECIFICATIONS

Year	Part Number	OEM HP/TQ Rating	HP Gain	Tube Diam	IC Mount	Drive System	Bypass System	Fuel System Upgrade	Fuel Inj. Supplied	Comp./Ignition Modifications	SC Warranty (in months)	CARB E.O.	Foot Notes
2006-10	1DJ214-SCI	425/425	160+	3"	V	stk 6 rib	ProFlow	MAP sensor, pump voltage booster	52 lb/hr	programmer sup.	12, 36 opt. (\$99)	D-365-9	II1
2006-10	1DJ204-SCI	425/425	specify	3"	V	stk 6 rib	ProFlow	not supplied	No	not supplied	12	-	II1
2006-10	1DJ314-SCI	425/425	160+	3"	V	add'l 8 rib	ProFlow	MAP sensor, pump voltage booster	52 lb/hr	programmer sup.	12, 36 opt. (\$99)	D-365-9	II1, II7
2006-10	1DJ304-SCI	425/425	specify	3"	V	add'l 8 rib	ProFlow	not supplied	No	not supplied	12	-	II1, II7

2020-21 JEEP GLADIATOR JT (3.6) SPECIFICATIONS

Year	Part Number	OEM HP/TQ Rating	HP Gain	Tube Diam	IC Mount	Drive System	Bypass System	Fuel System Upgrade	Fuel Inj. Supplied	Comp./Ignition Modifications	SC Warranty (in months)	CARB E.O.	Foot Notes
2020-21	1JT214-SCI	285/260	45%+	2.5-3"	V	stk 6 rib	ProFlow	not required	50 lb/hr	programmer sup.	12, 36 opt. (\$99)	D-365-19	II1, II2, II3, II4, II5, II6
2020-21	1JT204-SCI	285/260	specify	2.5-3"	V	stk 6 rib	ProFlow	not supplied	No	not supplied	12	-	II1, II2, II3, II5

2018-21 JEEP WRANGLER JL (3.6) SPECIFICATIONS

Year	Part Number	OEM HP/TQ Rating	HP Gain	Tube Diam	IC Mount	Drive System	Bypass System	Fuel System Upgrade	Fuel Inj. Supplied	Comp./Ignition Modifications	SC Warranty (in months)	CARB E.O.	Foot Notes
2018-21	1JL214-SCI	285/260	45%+	2.5-3"	V	stk 6 rib	ProFlow	not required	50 lb/hr	programmer sup.	12, 36 opt. (\$99)	D-365-19	II1, II2, II3, II4, II5, II6
2018-21	1JL204-SCI	285/260	specify	2.5-3"	V	stk 6 rib	ProFlow	not supplied	No	not supplied	12	-	II1, II2, II3, II5

2012-18 JEEP WRANGLER JK (3.6) SPECIFICATIONS

Year	Part Number	OEM HP/TQ Rating	HP Gain	Tube Diam	IC Mount	Drive System	Bypass System	Fuel System Upgrade	Fuel Inj. Supplied	Comp./Ignition Modifications	SC Warranty (in months)	CARB E.O.	Foot Notes
2012-18	1JK214-SCI	285/260	50%+	2.5-3"	V	stk 6 rib	ProFlow	not required	50 lb/hr	programmer sup.	12, 36 opt. (\$99)	D-365-19	II1, II2, II3, II4, II5, II6
2012-18	1JK204-SCI	285/260	specify	2.5-3"	V	stk 6 rib	ProFlow	not supplied	No	not supplied	12	-	II1, II2, II3, II5

JEEP WRANGLER, GLADIATOR, & GRAND CHEROKEE FOOTNOTES (specific to above applications):

- II1) Model year must be specified
- II2) Specify 2WD or 4WD
- II3) Specify manual or automatic transmission
- II4) Due to variability among OEM computers, and the prevalence of custom modifications, dyno tuning may be required
- II5) May not work with some aftermarket parts or accessories
- II6) 2015+ vehicles may require ECM unlock (call for details)
- II7) Requires ATI Performance Products balancer #918432 (not included - specify hardened hub)
- II8) Some trimming required to airbox tabs



2010-20 TOYOTA 4RUNNER (4.0) SYSTEMS & KITS

Year	Part Number	Description	Boost Options	HP Gain	Intercooler	Price
2010-20	1TK212-SCI	High Output Intercooled System with D-1SC	7-8 psi	40-45%	3 core	\$6,499
2010-20	1TK202-SCI	High Output Intercooled Tuner Kit with D-1SC	specify	specify	3 core	\$5,599

2010-20 4RUNNER (4.0) OPTIONS	add "-B" or "-P" to part #	Black or Polished finish for ProCharger	satin standard	-	-	+\$295
	add "-BB" or "-PB" to part #	Black or Polished finish for supercharger bracket	satin standard	-	-	+\$250
	add "-BC"	Black finish for intake manifold cover	unfinished std	-	-	\$30
	add "-H" to part #	Helical gearset for noise reduction	same	same	-	+\$100
	add "-IU" to part #	Air-to-Air intercooler option for aftermarket bumper and/or winch	from standard	-	-	n/c
	add "-MC"	Optional ProCharger intake manifold cover (satin)	unfinished std	-	-	+\$129

2016-21 TOYOTA TACOMA (3.5) SYSTEMS & KITS

Year	Part Number	Description	Boost Options	HP Gain	Intercooler	Price
2016-21	1TM212SCI	High Output Intercooled System with D-1SC	7-8 psi	40-45%	3 core	\$6,699
2016-21	1TM202SCI	High Output Intercooled Tuner Kit with D-1SC	specify	specify	3 core	\$5,799

2005-15 TOYOTA TACOMA (4.0) SYSTEMS & KITS

Year	Part Number	Description	Boost Options	HP Gain	Intercooler	Price
2005-15	1TL212-SCI	High Output Intercooled System with D-1SC	7-8 psi	40-45%	3 core	\$6,199
2005-15	1TL202-SCI	High Output Intercooled Tuner Kit with D-1SC	specify	specify	3 core	\$5,299

2005-21 TACOMA (3.5,4.0) OPTIONS	add "-B" or "-P" to part #	Black or Polished finish for ProCharger	satin standard	-	-	+\$295
	add "-BB" or "-PB" to part #	Black or Polished finish for supercharger bracket	satin standard	-	-	+\$250
	add "-BC"	Black finish for intake manifold cover	unfinished std	-	-	+\$30
	add "-H" to part #	Helical gearset for noise reduction	same	same	-	+\$100
	add "-IU" to part #	Air-to-Air intercooler upgrade for aftermarket bumper and/or winch	from standard	-	-	n/c
	add "-BI" to part #	Black finish for intercooler	satin standard	-	-	+\$150

2007-20 TOYOTA TUNDRA (5.7) SYSTEMS & KITS - COMING SOON

SPECIFICATIONS (4RUNNER, TACOMA, TUNDRA)

2010-20 TOYOTA 4RUNNER (4.0) SPECIFICATIONS

Year	Part Number	OEM HP/TQ Rating	HP Gain	Tube Diam	IC Mount	Drive System	Bypass System	Fuel System Upgrade	Fuel Inj. Supplied	Comp./Ignition Modifications	SC Warranty (in months)	CARB E.O.	Foot Notes
2010-20	1TK212-SCI	270/278	40-45%+	3"	V	add'l 6 rib	ProFlow	-	60 lb/hr	programmer sup.	12	-	TT1, TT2, TT3, TT4, TT5, TT7, TT8
2010-20	1TK202-SCI	270/278	specify	3"	V	add'l 6 rib	ProFlow	not supplied	No	not supplied	12	-	TT1, TT2, TT3, TT4, TT5, TT7, TT8

2016-21 TOYOTA TACOMA (3.5) SPECIFICATIONS

Year	Part Number	OEM HP/TQ Rating	HP Gain	Tube Diam	IC Mount	Drive System	Bypass System	Fuel System Upgrade	Fuel Inj. Supplied	Comp./Ignition Modifications	SC Warranty (in months)	CARB E.O.	Foot Notes
2016-21	1TM212-SCI	278/265	TBD	3"	V	stk 6 rib	ProFlow	-	-	programmer sup.	12	-	TT1, TT2, TT3, TT4, TT5, TT6, TT7, TT8, TT9
2016-21	1TM202-SCI	278/265	specify	3"	V	stk 6 rib	ProFlow	not supplied	No	not supplied	12	-	TT1, TT2, TT3, TT4, TT5, TT6, TT7, TT8, TT9

2005-15 TOYOTA TACOMA (4.0) SPECIFICATIONS

Year	Part Number	OEM HP/TQ Rating	HP Gain	Tube Diam	IC Mount	Drive System	Bypass System	Fuel System Upgrade	Fuel Inj. Supplied	Comp./Ignition Modifications	SC Warranty (in months)	CARB E.O.	Foot Notes
2005-15	1TL212-SCI	236/266	40-45%+	3"	V	add'l 6 rib	ProFlow	pump voltage booster	52 lb/hr	programmer sup.	12	-	TT1, TT2, TT3, TT4, TT5, TT6, TT7
2005-15	1TL202-SCI	236/266	specify	3"	V	add'l 6 rib	ProFlow	not supplied	No	not supplied	12	-	TT1, TT2, TT3, TT4, TT5, TT6, TT7

TOYOTA 4RUNNER, TACOMA, TUNDRA FOOTNOTES (specific to above applications):

- TT1) Model year must be specified
- TT2) Specify 2WD or 4WD or AWD
- TT3) Specify manual or automatic transmission
- TT4) Due to variability among OEM computers, and the prevalence of custom modifications, dyno tuning may be required
- TT5) May not work with some aftermarket parts or accessories
- TT6) Radiator support modification required
- TT7) Specify with or without winch/snorkel option
- TT8) Battery relocation required (supplied)
- TT9) Passenger side ABS requires race air inlet

2015-19 POLARIS SLINGSHOT

Year	Part Number	Description	Boost Options	HP Gain	Intercooler	Price
2015-19	1PD112-SCI	High Output Intercooled System with CS-1	8 psi	55%+	3 core	\$5,699
2015-19	1PD102-SCI	High Output Intercooled Tuner Kit with CS-1	specify	specify	3 core	\$5,499

OPTIONS	add "-B" or "-P" to part #	Black or Polished finish for ProCharger	satin standard	-	-	+\$295
	add "-BB" or "-PB" to part #	Black or Polished finish for supercharger bracket	satin standard	-	-	+\$250

2003-06 NISSAN 350Z (3.5) TUNER KITS (DOES NOT FIT 2006 REV-UP ENGINE MODEL)

Year	Part Number	Description	Boost Options	Est. HP Gain	Intercooler	Price
2003-06	1NB202-SCI	High Output Intercooled Tuner Kit with C-2	7 psi	55-60%	350Z	\$5,999

OPTIONS	add "-P" to part #	Polished finish for ProCharger (7" housing)	head unit only	-	-	+\$225
---------	--------------------	---	----------------	---	---	--------

2003-04 INFINITI G35 COUPE AND FX35 (3.5) TUNER KITS

Year	Part Number	Description	Boost Options	Est. HP Gain	Intercooler	Price
2003-04	1NC202-SCI	High Output Intercooled Tuner Kit with C-2	6 psi	45-50%	G35	\$5,999

OPTIONS	add "-P" to part #	Polished finish for ProCharger (7" housing)	head unit only	-	-	+\$225
---------	--------------------	---	----------------	---	---	--------

1999-00 HONDA CIVIC Si (1.6 DOHC) TUNER KITS

Year	Part Number	Description	Boost Options	Est. HP Gain	Intercooler	Price
1999-00	1HA202-SCI	High Output Intercooled Tuner Kit with C-1A	9 psi	70-75%	2 core	\$5,399

OPTIONS	add "-P" to part #	Polished finish for ProCharger (7" housing)	head unit only	-	-	+\$225
	add "-3C" to part #	3 core intercooler system upgrade	from 2 core	-	-	+\$345

1994-01 ACURA INTEGRA GSR AND TYPE R (1.8 DOHC) TUNER KITS

Year	Part Number	Description	Boost Options	Est. HP Gain	Intercooler	Price
1994-01	1HB202-SCI	High Output Intercooled Tuner Kit with C-1A	8 psi	70-75%	2 core	\$5,399

OPTIONS	add "-P" to part #	Polished finish for ProCharger (7" housing)	head unit only	-	-	+\$225
	add "-3C" to part #	3 core intercooler system upgrade	from 2 core	-	-	+\$345

2000-04 FORD FOCUS (ZETEC, SVT) TUNER KITS

Year	Part Number	Description	Boost Options	Est. HP Gain	Intercooler	Price
2000-03	1FK202-SCI	High Output Intercooled Tuner Kit with C-1B (Zetec)	8, 10 psi	65-80%	Focus	\$4,999
2002-04	1FK302-SCI	High Output Intercooled Tuner Kit with C-1B (SVT)	8, 10 psi	65-80%	Focus	\$4,999

OPTIONS	add "-P" to part #	Polished finish for ProCharger (7" housing)	head unit only	-	-	+\$225
---------	--------------------	---	----------------	---	---	--------

LOOKING FOR V-TWIN OR POWERSPORTS SUPERCHARGER SYSTEMS? GIVE US A CALL!

SPECIFICATIONS (SPORT COMPACT / SLINGSHOT)

2015-19 POLARIS SLINGSHOT SPECIFICATIONS

Year	Part Number	OEM HP Rating	HP Gain	Tube Diam	Intercooler Mount	Drive System	Bypass System	Fuel System Upgrade	Fuel Inj. Supplied	Computer/Ignition Modifications	Supercharger Warranty (in months)	CARB E.O.	Foot Notes
2015-19	1PD112-SCI	173	55%+	2.5"	V	stk 6 rib	ProFlow Bullet	not required	not req.	tuning certificate	12	-	-
2015-19	1PD102-SCI	173	specify	2.5"	V	stk 6 rib	ProFlow Bullet	not required	No	No	12	-	-

2003-06 NISSAN 350Z (3.5) SPECIFICATIONS

Year	Part Number	OEM HP Rating	Est. HP Gain	Tube Diam	Intercooler Mount	Drive System	Bypass System	Fuel System Upgrade	Fuel Inj. Supplied	Computer/Ignition Modifications	Supercharger Warranty (in months)	CARB E.O.	Foot Notes
2003-06	1NB202-SCI	287	55-60%	2.5"	V	stk 6 rib	ProFlow	not supplied	No	not supplied	12	-	JJ1, JJ3, JJ5, JJ6

2003-04 INFINITI G35 COUPE, FX35 (3.5) SPECIFICATIONS

Year	Part Number	OEM HP Rating	Est. HP Gain	Tube Diam	Intercooler Mount	Drive System	Bypass System	Fuel System Upgrade	Fuel Inj. Supplied	Computer/Ignition Modifications	Supercharger Warranty (in months)	CARB E.O.	Foot Notes
2003-04	1NC202-SCI	280	45-50%	2.5"	V	stk 6 rib	ProFlow	not supplied	No	not supplied	12	-	JJ1, JJ5, JJ6

1999-00 HONDA CIVIC Si (1.6L DOHC) SPECIFICATIONS

Year	Part Number	OEM HP Rating	Est. HP Gain	Tube Diam	Intercooler Mount	Drive System	Bypass System	Fuel System Upgrade	Fuel Inj. Supplied	Computer/Ignition Modifications	Supercharger Warranty (in months)	CARB E.O.	Foot Notes
1999-00	1HA202-SCI	160	70-75%	2.5"	V	stk 4 rib	Bosch	not supplied	No	not supplied	12	-	JJ1, JJ5, JJ6

1994-01 ACURA INTEGRA GSR, TYPE R (1.8L DOHC) SPECIFICATIONS

Year	Part Number	OEM HP Rating	Est. HP Gain	Tube Diam	Intercooler Mount	Drive System	Bypass System	Fuel System Upgrade	Fuel Inj. Supplied	Computer/Ignition Modifications	Supercharger Warranty (in months)	CARB E.O.	Foot Notes
1994-01	1HB202-SCI	170	70-75%	2.5"	V	stk 4 rib	Bosch	not supplied	No	not supplied	12	-	JJ1, JJ2, JJ4, JJ5, JJ6

2000-04 FORD FOCUS (ZETEC, SVT) SPECIFICATIONS

Year	Part Number	OEM HP Rating	Est. HP Gain	Tube Diam	Intercooler Mount	Drive System	Bypass System	Fuel System Upgrade	Fuel Inj. Supplied	Computer/Ignition Modifications	Supercharger Warranty (in months)	CARB E.O.	Foot Notes
2000-03	1FK202-SCI	130	65-80%	2.5"	H	stk 6 rib	Bosch	not required	No	not supplied	12	-	JJ1, JJ5, JJ6
2002-04	1FK302-SCI	170	65-80%	2.5"	H	stk 6 rib	Bosch	not required	No	not supplied	12	-	JJ1, JJ5, JJ6

SPORT COMPACT FOOTNOTES (specific to above applications):

- JJ1) Model year must be specified
- JJ2) Specify GS-R or Type R
- JJ3) For Non Rev-up engines only
- JJ4) Acura Integra systems and kits require modifications to bumper support
- JJ5) Boost levels are for reference only—tuning and fuel system upgrades may be required (sold by others)
- JJ6) Special order kit: order form and non-refundable deposit required at time of order—may require additional lead time for processing



	A-1R	B-1	CS-1	C-1	C-2	P600B	P-1SC	P-1SC-1	P-1X	P-1SC-2	D-1	D-1SC	D-1X	F-1D	F-1	F-1A	F-1A-91	F-1A-94	
VOLUTE DIAMETER	7"	7"	7"	7"	7"	9"	9"	9"	9"	9"	9"	9"	9"	9"	9"	9"	9"	9"	9"
MAX SUPERCHARGED HP	150	250	550	675	725	775	825	825	950	825	925	925	1075	1050	1050	1100	1200	1300	
MOTOR BASE HP RANGE*	50-95	60-150	150-325	150-325	175-375	200-500	200-500	200-450	300-500	200-450	300-500	300-500	300-550	300-500	300-500	300-500	300-500	300-550	
MAX FLOW (CFM)	450	600	900	1000	1000	1150	1200	1200	1275	1200	1400	1400	1500	1500	1525	1575	1600	1625	
MAX BOOST (PSI)	15	20	24	24	24	24	30	32	32	30	32	32	32	34	38	38	38	38	
INLET HOSE DIAMETER	3"	3"	3.5"	3.5"	3.5"	3.75"	3.75"	3.75"	3.75"	3.75"	3.75"	3.75"	3.75"	3.75"	3.75"	3.75"	3.75"	3.75"	4"
INDUCER DIAMETER	2.28"	2.28"	2.66"	2.75"	3.14"	3.37"	3.37"	3.37"	3.57"	3.24"	3.37"	3.37"	3.57"	3.37"	3.57"	3.5"	3.57"	3.7"	
EXDUCER DIAMETER	3.2"	3.2"	3.7"	4.25"	4.25"	6.25"	6.25"	5.25"	5.56"	6"	6.25"	6.25"	6.20"	6.25"	6"	5.56"	5.56"	5.56"	
OUTLET HOSE DIAMETER	2"	2"	2.5"	2.5"	2.5"	3"	3"	3"	3"	3"	3"	3"	3"	3"	3"	3"	3"	3"	
OUTLET I.D.	1.75"	1.75"	2.12"	2.12"	2.12"	2.62"	2.62"	2.62"	2.62"	2.62"	2.62"	2.62"	2.62"	2.62"	2.62"	2.62"	2.62"	2.62"	
MAX IMPELLER RPM	75,000	11,000	80,000	80,000	80,000	60,000	62,000	65,000	65,000	60,000	65,000	62,000	62,000	65,000	70,000	74,000	74,000	74,000	
INTERNAL STEP-UP	4.11:1	4.95:1	8.30:1	4.70:1	4.70:1	3.05:1	4.10:1	4.10:1	4.10:1	4.10:1	4.44:1	4.10:1	4.10:1	5.40:1	5.40:1	5.40:1	5.40:1	5.40:1	
REVERSE ROTATION OPTION	Yes	Yes	Yes	Yes	Yes	Yes	Yes	Yes	Yes	Yes	Yes	Yes	Yes	Yes	Yes	Yes	Yes	Yes	
SELF CONTAINED	Yes	Yes	Yes	Yes	Yes	No	Yes	Yes	Yes	Yes	No	Yes	Yes	Yes	Yes	Yes	Yes	Yes	
OIL CAPACITY	2.5 oz	2.5 oz	3.2 oz	2.5 oz	2.5 oz	-	6 oz	6 oz	6 oz	6 oz	-	6 oz	6 oz	4 oz	4 oz	4 oz	4 oz	4 oz	

• The stated figures are not absolutes, and may actually be higher depending upon the specific application.

• Figures based on stated peak airflows; actual power levels may be higher in well prepared engines.

• Engine intake air temperature is the most relevant thermal measure (not SAE J1723) for a supercharger installed on a vehicle, especially when intercooled; SAE J1723 does not address the impact of engine dynamics, engine compartment heat transfer, intercooling or deficiencies caused by supercharger location.

• Please refer to www.procharger.com for additional supercharger specifications.

RACE SUPERCHARGER SPECIFICATIONS

EFFECTIVE DATE 04/30/21

	F-1C	F-1R	F-1X	F-2	F-3D-102	F-3D-106	F-1X-12 F-3R-112	F-3R-121	F-3R-130	F-3R-136	F-3R-140	F-3X-140	F-4X-140	F-4X-142
VOLUTE DIAMETER	9.75"	9.75"	10.5"	10.5"	10.5"	10.5"	12"	12"	12"	12"	12"	13.5"	13.5"	TBD
MAX SUPERCHARGED HP	1100	1250	1400	1450	1500	1800	2100	2400	2700	3000	3400	3500	3500	TBD
MOTOR BASE HP RANGE	300-550	375-550	375-550	425-600	375-550	375-550	375-550	500-580	600-900	700-1000	700-1000	700-1000	700-1000	TBD
MAX FLOW (CFM)	1625	1700	2000	2700	1900	2200	2300	3100	3600	4000	4400	4500	4500	TBD
MAX BOOST (PSI)	38	38	38	38	38	38	38	40	45	500	58	60	60	TBD
INLET HOSE DIAMETER	4"	4.05"	4.8"	4.6"	4.8"	4.8"	5"	5.5"	5.75"	5.75"	5.75"	6"	6"	TBD
INDUCER DIAMETER	3.7"	4"	4.20"	4.5"	4"	4.2"	4.4"	4.8"	5.12"	5.35"	5.47"	5.47"	5.47"	TBD
EXDUCER DIAMETER	5.56"	6"	6"	6.75"	6"	6"	6.75"	6.75"	7.22"	7.22"	7.22"	7.22"	7.22"	TBD
OUTLET HOSE DIAMETER	3"	3"	3.5"	3.5"	3.5"	3.5"	4"	4"	4"	4"	4"	4.5"	4.5"	TBD
OUTLET I.D.	2.62"	2.62"	3.15"	3.15"	3.15"	3.15"	3.59"	3.59"	3.59"	3.59"	3.59"	4"	4"	TBD
MAX IMPELLER RPM	74,000	68,000	72,000	65,000	74,000	74,000	72,000	72,000	72,000	72,000	72,000	72,000	72,000	TBD
INTERNAL STEP-UP	5.40:1	5.40:1	5.40:1	5.40:1	5.63:1	5.63:1	5.63:1	5.63:1	5.63:1	5.63:1	5.63:1	5.63:1	4.77:1	TBD
REVERSE ROTATION OPTION	Yes	Yes	Yes	Yes	Yes	Yes	Yes	Yes	Yes	Yes	No	No	No	TBD
SELF CONTAINED	Yes	Yes	Yes	Yes	Yes	Yes	Yes	Yes	Yes	Yes	Yes	Yes	Yes	TBD
OIL CAPACITY	4 oz	4 oz	4 oz	4 oz	4 oz	4 oz	4 oz	4 oz	4 oz	4 oz	6 oz	6 oz	6 oz	TBD

- F-1/F-2 superchargers are rated based upon high horsepower street engines. F-3 superchargers are rated based upon maximum effort race engines.
- The stated figures are not absolutes, and may actually be higher depending upon the specific application.
- Please refer to www.procharger.com for additional supercharger specifications.

- Figures based on stated peak airflows; actual power levels may be higher in well prepared engines.
- Engine intake air temperature is the most relevant thermal measure (not SAE J1723) for a supercharger installed on a vehicle, especially when intercooled; SAE J1723 does not address the impact of engine dynamics, engine compartment heat transfer, intercooling or deficiencies caused by supercharger location.

The supercharger Clocking and Rotation is determined with impeller facing away from you.

CLOCKING

The oil slinger must always be at bottom (6:00) when installed in main bracket.

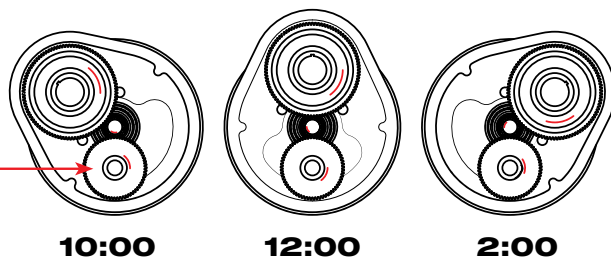

10:00

12:00

2:00

ROTATION

The volute (compressor housing) can be rotated a full 360°

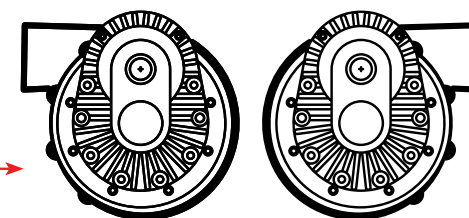

S = Standard R = Reverse

FORD AUTO	Clocking	Rotation
2015-20 Mustang GT (5.0 4V)	10:00	R
2015-20 GT350 and GT350R (5.2 4V)	10:00	R
2015-17 Mustang V6 (3.7)	2:00	R
2011-14 Mustang GT (5.0 4V Shared Drive)	10:00	R
2011-14 Mustang GT (5.0 4V)	10:00	S
2011-14 Mustang V6 (3.7)	2:00	R
2012-13 Boss 302 Mustang (Shared Drive)	10:00	R
2012-13 Boss 302 Mustang	10:00	S
2005-10 Mustang GT (4.6 3V Shared Drive)	12:00	R
2005-10 Mustang GT (4.6 3V)	2:00	S
2005-10 3V Cog Race Kits	2:00	S
2005-10 Mustang V6 (4.0)	10:00	R
1999-04 Mustang GT and Bullitt (4.6 2V)	10:00	R
2003-04 Mustang Mach 1 (4.6 4V)	10:00	R
1996-98 Mustang GT (4.6 2V)	10:00	R
1994-04 Mustang V6 (3.8, 3.9)	10:00	R
2003-04 Cobra (4.6 4V) Serpentine	10:00	R
2003-04 Cobra (4.6 4V) Cog	2:00	R
1999-01 Cobra (4.6 4V)	10:00	R
1996-98 Cobra (4.6 4V)	10:00	R
1996-98 Cobra (4.6 4V) Serpentine Race Kit	10:00	R
1996-98 Cobra (4.6 4V) Cog Race Kit	2:00	R
1994-95 Mustang and Cobra (5.0)	12:00	S
1986-93 Mustang and Cobra (5.0)	2:00	S
1964.5-66 Mustang (289, 302, 351 V8)	2:00	S
Carb/Aftermarket EFI Serpentine Kits	2:00	S
Carb/Aftermarket EFI Cog Race Kits	2:00	R or S
Coyote Swap (5.0 4V) Kits	10:00	S
Godzilla Swap (7.3) Kits	12:00	R

CHEVROLET CORVETTE	Clocking	Rotation
2020-21 Corvette C8 (LT2)	2:00	S
2014-19 Corvette C7 (LT1)	10:00	R
2015-19 Corvette C7 Z06 (LT4)	10:00	R
2006-13 Corvette C6 and Z06 (LS3, LS7)	2:00	R
2005-07 Corvette C6 (LS2)	2:00	R
1997-04 Corvette C5, Z06 (LS1, LS6)	2:00	R
1992-96 Corvette C4 (LT1, LT4)	2:00	R
1985-91 Corvette C4 TPI (L98)	12:00	S

GM AUTO	Clocking	Rotation
2016-19 Cadillac CTS-V (LT4)	2:00	S
2016-21 Camaro SS (LT1 Shared Drive)	2:00	R
2016-21 Camaro SS (LT1) and ZL1 (LT4)	2:00	S
2016-20 Camaro V6 (3.6)	2:00	R
2014-15 Camaro Z/28 (LS7)	10:00	S
2010-15 Camaro SS (LS3, L99) / Cog Race Kits	2:00	S
1998-02 Camaro/Firebird (LS1)	10:00	R
1993-97 Camaro/Firebird (LT1)	12:00	S
1987-92 Camaro/Firebird TPI (L98)	2:00	S
2014-17 Chevrolet SS	10:00	S
2008-09 Pontiac G8 GT and 2004-06 GTO	10:00	S
Carb/Aftermarket EFI Serpentine/Cog Kits	specify	specify
Carb/Aftermarket EFI Reverse Cog Race Kits	2:00	R
LS Swap Serpentine Kits	2:00	S
LS Swap Cog Race Kits	10:00	S
LT1/LT4 Swap Serpentine Kits (2014-17)	2:00	S

DODGE/CHRYSLER AUTO	Clocking	Rotation
2008-21 Challenger (5.7, 6.1, 6.4)	2:00	S
2011-14 Challenger Stage II (6.4)	10:00	S
2011-20 Challenger V6 (3.6)	10:00	S
2008-10 Challenger SRT8 Stage II (6.1)	2:00	R
2006-21 Charger (5.7, 6.1, 6.4)	2:00	S
2006-10 Charger Stage II (5.7, 6.1)	2:00	R
2005-18 Chrysler 300/Dodge Magnum	2:00	S
HEMI Reverse Cog Race Kits	10:00	R

GM TRUCK/SUV	Clocking	Rotation
2019-21 GM Truck/SUV HO & Stage II (5.3, 6.2)	2:00	S
2015-19 GM Truck/SUV 2500 (6.0)	12:00	R
2014-18 GM Truck/SUV (5.3, 6.2)	2:00	S
2007-13 GM Truck/SUV (5.3, 6.0, 6.2, 4.8)	12:00	S
2003-07 GM Truck/SUV (5.3, 6.0, 4.8)	12:00	S
2003-09 Hummer H2 (6.2, 6.0)	12:00	S
1999-03 GM Truck/SUV (5.3, 6.0, 4.8)	12:00	S
1999-07 GM 2500 Truck (6.0)	12:00	S
1996-00 GM Truck/SUV (5.7)	2:00	S
1996-00 GM Truck/SUV (7.4)	10:00	S
1988-95 GM TBI Truck/SUV (5.7, 7.4)	2:00	S

FORD TRUCK/SUV	Clocking	Rotation
2020-21 F-250/350 Super Duty	10:00	S
2015-20 F-150 (5.0 4V)	10:00	S
2011-14 F-150 (5.0, 6.2 4V)	10:00	S
2010-14 SVT Raptor HO (6.2, 5.4 3V)	2:00	R
2010-14 SVT Raptor Stage II (6.2, 5.4 3V)	10:00	S
2004-10 F-150 (5.4 3V)	2:00	R
2007-14 Expedition (5.4 3V)	2:00	R
1997-03 F-150/Expedition (5.4, 4.6 2V)	10:00	S

DODGE/RAM TRUCK/SUV	Clocking	Rotation
2018-21 Durango SRT (6.4)	2:00	S
2014-21 Ram 2500/3500 and Power Wagon (6.4)	10:00	R
2019-21 Ram eTorque (5.7)	10:00	S
2019-21 Ram (5.7)	10:00	S
2009-20 Ram (5.7)	10:00	S
2004-08 Dodge Ram (5.7)	2:00	S
1996-01 Dodge Ram (5.9, 5.2)	12:00	S
1997-01 Dodge Dakota/Durango (5.9, 5.2)	10:00	S

JEEP	Clocking	Rotation
2012-20 Grand Cherokee SRT (6.4)	2:00	S
2011-20 Grand Cherokee (5.7)	2:00	S
2006-10 Grand Cherokee SRT8 HO (6.1)	2:00	R
2006-10 Grand Cherokee SRT8 Stage II (6.1)	10:00	S
2012-21 Wrangler JL - JK 2012-18 (3.6)	12:00	R
2020-21 Gladiator JT (3.6)	12:00	R

TOYOTA	Clocking	Rotation
2010-20 4Runner (4.0)	2:00	R
2016-21 Tacoma (3.5)	2:00	R
2005-15 Tacoma (4.0)	10:00	S

SPORT COMPACT / SLINGSHOT	Clocking	Rotation
2015-19 Polaris Slingshot	2:00	S
2003-06 Nissan 350Z (3.5)	2:00	R
2003-04 Infiniti G35 Coupe and FX35 (3.5)	10:00	R
1999-00 Honda Civic Si (1.6)	2:00	S
1994-01 Acura Integra GSR/Type R (1.8)	2:00	S
2000-03 Ford Focus (ZETEC) / 2002-04 Focus (SVT)	2:00	R

STREET/STRIP SUPERCHARGER PULLEYS

EFFECTIVE DATE 04/30/21



STANDARD

Standard pulleys come with shoulders on both sides, and a shaft that is also flush with the shoulders.



OFFSET

The shaft on an offset pulley extends past one shoulder, to position the belt farther away from the supercharger.



SINGLE-SHOULDER

These pulleys have a shoulder on only one side of the pulley to accommodate tighter fitment.



COG

Cog pulleys have "teeth" instead of ribs, to avoid belt slip. Used for a variety of vehicles and hp levels, typically for racing/off-road.

FORD AUTO	Pulley	Ribs
2015-20 Mustang GT (5.0 4V Shared Drive)	Single Shoulder	6
2015-20 Mustang GT HO (5.0 4V)	Standard	6
2015-20 Mustang GT Stage II (5.0 4V)	Standard	8
2015-20 GT350/GT350R (5.2 4V)	Standard	8
2015-17 Mustang V6 (3.7)	Standard	6
2011-14 Mustang GT (5.0 4V Shared Drive)	Standard	6
2011-14 Mustang GT HO/Stage II (5.0 4V)	Standard	8
2011-14 Mustang GT Cog Race (5.0 4V)	Cog	-
2011-14 Mustang V6 (3.7)	Standard	6
2012-13 Boss 302 Mustang (Shared Drive)	Standard	6
2012-13 Boss 302 Mustang Stage II	Standard	8
2012-13 Boss 302 Mustang Cog Race	Cog	-
2005-10 Mustang GT (4.6 3V Shared Drive)	Offset	6
2005-10 Mustang GT HO/Stage II (4.6 3V)	Standard	8
2005-10 Mustang GT Race (4.6 3V)	Standard	12
2005-10 3V Cog Race KITS	Cog	-
2005-10 Mustang V6 (4.0)	Standard	6
1999-04 Mustang GT/2001 Bullitt (4.6 2V)	Standard	6
2003-04 Mustang Mach 1 (4.6 4V)	Single Shoulder	6
1996-98 Mustang GT (4.6 2V) SYSTEMS	Standard	6
1994-04 Mustang V6 (3.8, 3.9)	Single Shoulder	6
2003-04 Cobra HO/Stage II (4.6 4V)	Standard	6
2003-04 Cobra Cog Race (4.6 4V)	Cog	-
1996-01 Cobra (4.6 4V)	Single Shoulder	6
1996-98 Cobra Serpentine Race (4.6 4V)	Standard	8
1996-98 Cobra Cog Race (4.6 4V)	Cog	-
1994-95 Mustang/Cobra (5.0)	Offset	6
1986-93 Mustang/Cobra (5.0) (no A/C, A/C)	Offset, Standard	8 or 12
1964.5-66 Mustang (289, 302, 351 V8)	Offset	8
Carb/Aftermarket EFI Serpentine Kits	Standard or Offset	8 or 12
Carb/Aftermarket EFI Cog Race Kits	Cog	-
Coyote Engine Swap HO (5.0 4V)	Standard	8
Coyote Engine Swap Cog Race (5.0 4V)	Cog	-
Godzilla Engine Swap (7.3)	Standard	8

CHEVROLET CORVETTE	Pulley	Ribs
2020-21 Corvette C8 (LT2)	Cog	-
2014-19 Corvette C7 (LT1)	Offset	8 or 10
2015-19 Corvette C7 Z06 (LT4)	Offset	8 or 10
2005-13 Corvette C6 HO/Stage II	Standard	6
2005-13 Corvette C6 Race	Standard	10
1997-04 Corvette C5, Z06 Stage II (LS1, LS6)	Standard	6
1997-04 Corvette C5, Z06 Race (LS1, LS6)	Standard	8
1985-96 Corvette C4 (LT1, LT4, L98)	Standard	6

GM AUTO	Pulley	Ribs
2016-19 Cadillac CTS-V (LT4)	Standard	8 or 10
2016-21 Camaro SS (LT1) and ZL1 (LT4)	Standard	8 or 10
2016-20 Camaro V6 (3.6)	Standard	6
2014-15 Camaro Z/28 (LS7)	Standard	8
2010-15 Camaro SS HO (LS3, L99)	Standard	8
2010-15 Camaro SS Stage II (LS3, L99)	Standard	8 or 12
2010-15 Camaro SS Cog Race	Cog	-
1998-02 Camaro/Firebird HO (LS1)	Standard	6 or 8
1998-02 Camaro/Firebird Race (LS1)	Standard	8 or 10
1993-97 Camaro/Firebird HO (LT1)	Offset	8
1993-97 Camaro/Firebird Race (LT1)	Offset	12
1987-92 Camaro/Firebird TPI (L98)	Standard or Offset	8
2014-17 Chevrolet SS / 08-09 G8 GT/04-06 GTO	Standard	8
Carb/Aftermarket EFI Serpentine Kits	Offset	8 or 12
Carb/Aftermarket EFI Cog Race Kits	Cog	-
LS Engine Swap Serpentine Kits	Offset	8
LS Engine Swap Cog Race Kits	Cog	-
LT1/LT4 Engine Swap Serpentine (2014-17)	Standard	8

DODGE/CHRYSLER AUTO	Pulley	Ribs
2008-21 Challenger HO (5.7, 6.1, 6.4)	Standard	6
2008-21 Challenger Stage II (6.1, 6.4)	Standard	8
2011-20 Challenger V6 (3.6)	Standard	6
2006-21 Charger HO (5.7, 6.1, 6.4)	Standard	6
2006-21 Charger Stage II (5.7, 6.1, 6.4)	Standard	8
2005-20 Chrysler 300 (5.7, 6.1, 6.4)	Standard	6
2005-08 Magnum (5.7, 6.1)	Standard	6
Reverse Cog Race Kits	Cog	-

GM TRUCK/SUV	Pulley	Ribs
2019-21 Truck/SUV 1500 HO/Stage II (5.3, 6.2)	Standard	8
2014-18 Truck/SUV 1500/2500 (5.3, 6.0, 6.2)	Standard	6
2014-18 Truck/SUV 1500 Stage II (5.3, 6.2)	Standard	8
2007-13 Truck/SUV HO (5.3, 6.0, 6.2, 4.8)	Standard	6
2007-13 Truck/SUV Stage II (5.3, 6.0, 6.2, 4.8)	Standard	8
2003-07 Truck/SUV HO (5.3, 6.0, 4.8)	Standard	6
2003-07 Truck/SUV Stage II (5.3, 6.0, 4.8)	Standard	8
2003-09 Hummer H2 (6.2, 6.0)	Standard	6
1999-03 Truck/SUV HO (5.3, 6.0, 4.8)	Standard	6
1999-03 Truck/SUV Stage II (5.3, 6.0, 4.8)	Standard	8
1999-07 GM 2500 Truck (6.0)	Standard	6
1996-00 Truck/SUV (5.7)	Standard	6
1996-00 Truck/SUV (7.4)	Offset	6
1988-95 TBI Truck/SUV (5.7, 7.4)	Offset	6

FORD TRUCK/SUV	Pulley	Ribs
2020-21 F-250/350 Super Duty (7.3)	Offset	6
2011-20 F-150 (5.0 4V)	Standard	8
2011-14 F-150 (6.2 4V)	Standard	6
2010-14 SVT Raptor HO (6.2 3V)	Offset	6
2010-14 SVT Raptor Stage II (6.2 3V)	Standard	8
2010-14 SVT Raptor HO (5.4 3V)	Standard	6
2004-10 F-150 (5.4 3V)	Standard	6
2007-14 Expedition (5.4 3V)	Standard	6
1997-03 F-150/Expedition (5.4, 4.6 2V)	Standard	6

DODGE/RAM TRUCK/SUV	Pulley	Ribs
2018-21 Durango SRT (6.4)	Standard	6
2019-21 Ram HO (5.7)	Offset	6
2019-21 Ram Stage II (5.7)	Standard	8
2019-21 Ram eTorque	Standard	8
2011-21 Ram HO (5.7)	Offset	6
2011-21 Ram Stage II (5.7)	Standard	8
2014-21 Ram HO (6.4)	Standard	6
2009-10 Ram HO (5.7)	Offset	6
2009-10 Ram Stage II (5.7)	Standard	8
2004-08 Ram (5.7)	HEMI Offset	7
1996-01 Ram (5.9, 5.2) / 97-01 Dakota/Durango (5.9, 5.2)	7-rib Offset	7

JEEP	Pulley	Ribs
2012-20 Grand Cherokee SRT (6.4)	Standard	6
2011-20 Grand Cherokee (5.7)	Standard	6
2006-10 Grand Cherokee SRT8 HO (6.1)	Standard	6
2006-10 Grand Cherokee SRT8 Stage II (6.1)	Standard	8
2020-21 Gladiator JT (3.6)	Standard	6
2018-21 Wrangler JL (3.6)	Standard	6
2012-18 Wrangler JK (3.6)	Standard	6

TOYOTA	Pulley	Ribs
2010-20 4Runner (4.0)	Standard	6
2016-21 Tacoma (3.5)	Standard	6
2005-15 Tacoma (4.0)	Standard	6

SPORT COMPACT / SLINGSHOT	Pulley	Ribs
2015-19 Polaris Slingshot	Offset	6
2003-06 Nissan 350Z (3.5)	Cog	-
2003-04 Infiniti G35 Coupe/FX35 (3.5)	Cog	-
1999-00 Honda Civic Si (1.6 DOHC)	Civic	4
1994-01 Acura Integra GSR/Type R (1.8 DOHC)	Civic	4
2000-04 Ford Focus (ZETEC, SVT)	P600B	6

Use this intercooler chart to substitute the dimensions in for each of the various intercooler types and inlet/outlet positions shown below.
Dimensions are approximate.

AIR-TO-AIR INTERCOOLERS

Part #	End Tank Type	In/Out Location	In/Out DIA.	Max HP	Core Width	Height	Depth	Price
AI002A-001	Sheet Metal	Opposite Sides	3"	500	18	12.5	3	\$775
AIFP1A-004	Sheet Metal	Opposite Sides	3"	500	18	12.5	3.5	\$775
AIFP1A-001	Sheet Metal	Opposite Sides	3"	650	24	12.5	3.5	\$975
AI003A-001	Sheet Metal	Opposite Sides	3"	825	27	12.5	3	\$975
AI003A-002	Sheet Metal	Opposite Sides	3"	950	27	15	3	\$1,170
AIDD1A-071	Sheet Metal	Opposite Sides	3"	1000	24	20	3	\$1,350
AI003A-005	Sheet Metal	Opposite Sides	3.5"	1050	27	15	3	\$1,350
AI045A-001	Sheet Metal	Opposite Sides	3.5"	1300	27	12	4.5	\$1,586
AI006A-001	Sheet Metal	Opposite Sides	4"	1550	27	12	6	\$2,075
AJK1A-002	Sheet Metal	Opposite Sides Cross Flow	3"	375	18	11	3	\$999
AIFR1A-010	Sheet Metal	Opposite Sides Cross Flow	3"	650	29	12	3.5	\$999
AIGN2A-011	Sheet Metal	Opposite Sides Cross Flow	3"	800	29	12	4.5	\$1,199
AIFW1A-035	Sheet Metal	Opposite Sides Cross Flow	3.5"	1200	20	17.5	4.5	\$1,299
AIGU1A-001	Sheet Metal	Front, Cross Flow	3"	1000	34	9	4.5	\$1,199
AIDD1A-015	Sheet Metal	Top/Side	3"	750	24	17	3	\$999
AIG03A-001	Sheet Metal	Top/Side	3"	1050	27	13	3.5	\$1,250
AIG03A-003	Sheet Metal	Top/Side	3.5"	1300	27	12	4.5	\$1,350
AIG03A-004	Sheet Metal	Top/Side	3.5"/4"	1300	27	12	4.5	\$1,450
AI002A-003	Sheet Metal	Same Side	3"	500	18	12.5	3	\$775
AIGN1A-001	Sheet Metal	Same Side	3"	600	18	12.5	3.5	\$799
AI003A-003	Sheet Metal	Same Side	3"	825	27	12.5	3	\$899
AI003A-004	Sheet Metal	Same Side	3"	950	27	15	3	\$1,199
AIDG1A-073	Sheet Metal	Same Side	3"	1000	24	20	3	\$1,340
AI003A-006	Sheet Metal	Same Side	3.5"	1050	27	15	3	\$1,250
AI045A-002	Sheet Metal	Same Side	3.5"	1300	27	15	4.5	\$1,750
AI006A-002	Sheet Metal	Same Side	4"	1550	27	12	6	\$2,100
add -BI	Air-to-Air Intercooler Black Finish Optional Upgrade							+250

AIR-TO-AIR TWIN INTERCOOLERS

Part #	End Tank Type	In/Out Location	In/Out DIA.	Max HP	Core Width	Height	Depth	Price
AIGB1A-XXX	Twin Sheet Metal	Opposite Sides	2"	500 Per Pair	9	10.5	3	\$699
AIGA1A-XXX	Twin Sheet Metal	Opposite Sides	2.5"	750 Per Pair	9	11	3.5	\$725
AIGK1A-XXX	Twin Sheet Metal	Front/Side	3"	850 Per Pair	9	11	4.5	\$750

AIR-TO-WATER INTERCOOLERS

Part #	End Tank Type	In/Out Location	In/Out DIA.	Max HP	Core Width	Height	Depth	Price
AIGU1I-123	Sheet Metal/Billet	Same Side	3.5"	1500	12.5	10	12	\$1,499
W11005A-003	Sheet Metal	Same Side	3.5"	1500	13	11	9	\$1,699
W11005A-001	Sheet Metal	Same Side	4"	1800	9	13	19	\$2,199
W11005A-002	Sheet Metal	Same Side	4"	2400	13	13	23	\$2,699

**Note: add approximately 2" to the above measurements to the side(s) that have the air inlets/outlets.

AIR-TO-AIR TWIN

Front and Side Inlet/Outlet

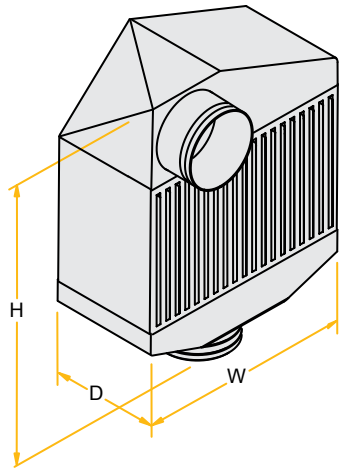

AIR-TO-AIR S/M

Opposite Side Inlet/Outlet

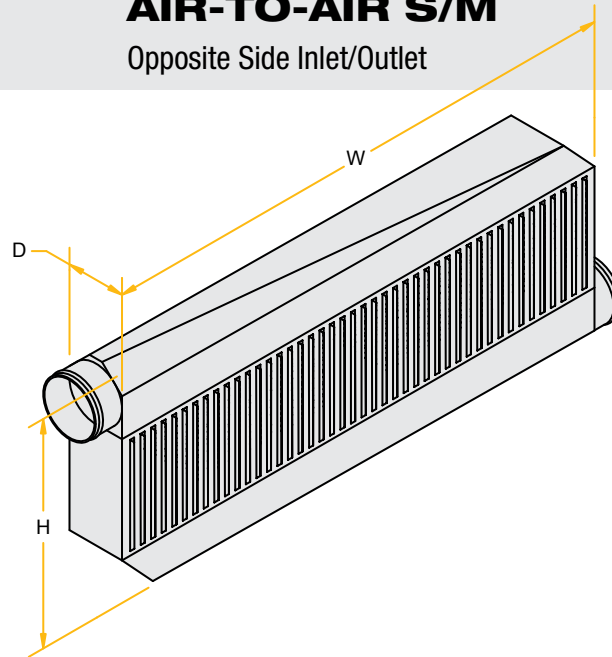

AIR-TO-AIR S/M

Opposite Inlet/Outlet, Cross-flow

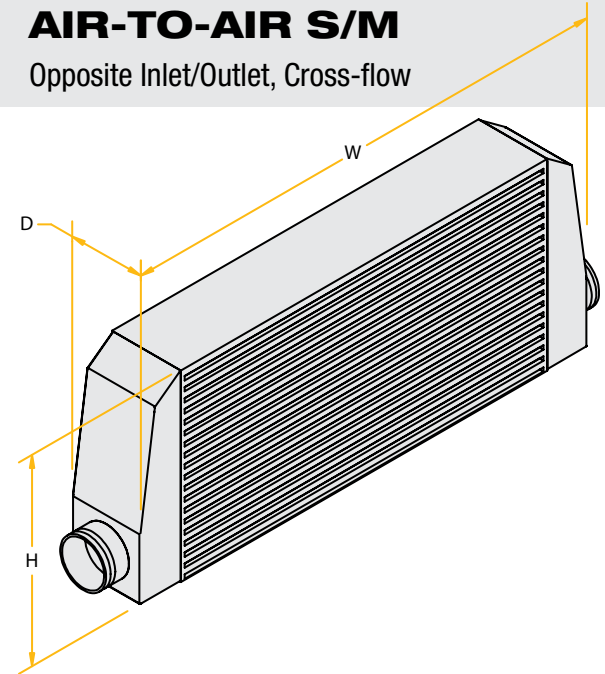

AIR-TO-AIR S/M

Top and Side Inlet/Outlet

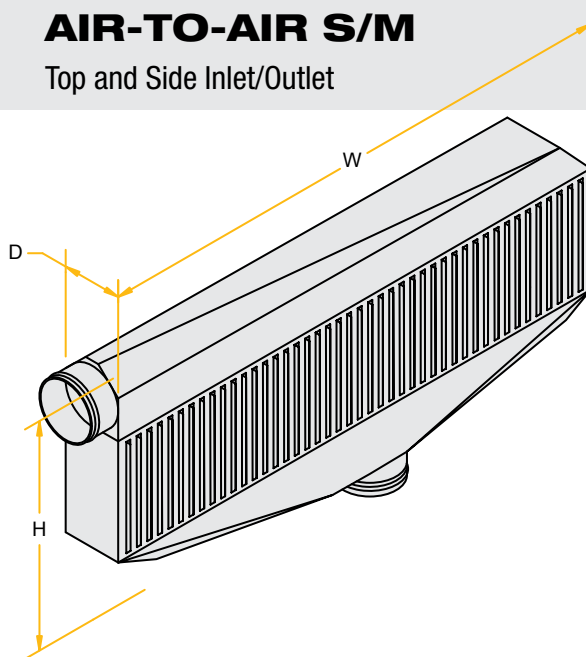

AIR-TO-AIR S/M

Same Side Inlet/Outlet

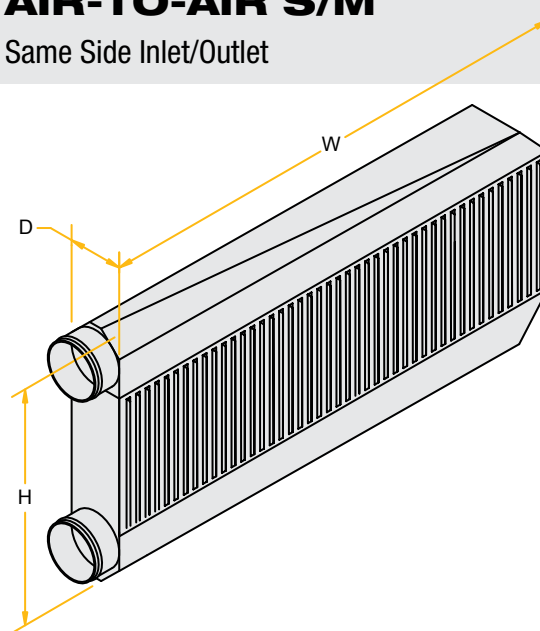

AIR-TO-WATER

Same Side Inlet/Outlet

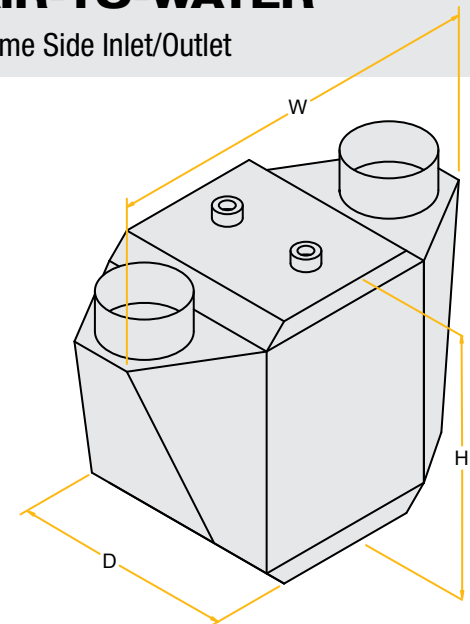

CRANKDRIVE™ (GEAR DRIVE)

Part Number	Description	Price
4CD-BBC-1	Chevrolet Big Block F-1 / F-2 CrankDrive	\$3,899
4CD-SBC-1	Chevrolet Small Block F-1 / F-2 CrankDrive	\$3,899
4CD-LSX-1	Chevrolet LSx F-1 / F-2 CrankDrive	\$3,899
4CD-SBF-1	Ford Small Block F-1 / F-2 CrankDrive	\$3,899
4CD-BBC-3	Chevrolet Big Block F-3 CrankDrive	\$3,999
4CD-SBC-3	Chevrolet Small Block F-3 CrankDrive	\$3,999
4CD-LSX-3	Chevrolet LSx F-3 CrankDrive	\$3,999
4CD-SBF-3	Ford Small Block F-3 CrankDrive	\$3,999
4CD-VED-3	Visner Small Block F-3 CrankDrive	\$4,399
4CD-MBR-3	MBR F-3 / F-4 CrankDrive (Requires MBR BBC Timing Cover, not included)	\$4,399
4CD-TFX-3	AJ TFX Hemi F-3 / F-4 CrankDrive	\$4,399
4CD-NON-3	NOONAN F-3 / F-4 CrankDrive	\$4,399
4CD-BAE-3	BAE Hemi F-3 / F-4 CrankDrive	\$4,399
4CD-481-3	481X F-3 / F-4 CrankDrive	\$4,399

REVERSE BELTDRIVE (CENTER MOUNT COG BELT)

Part Number	Description	Price
4BD-BBC-3	Chevrolet Big Block F-3 Reverse BeltDrive	\$3,499
4BD-SBC-3	Chevrolet Small Block F-3 Reverse BeltDrive	\$3,499
4BD-LSX-3	Chevrolet LSx F-3 Reverse BeltDrive	\$3,499
4BD-SBF-3	Ford Small Block F-3 Reverse BeltDrive	\$3,499

Call for availability on additional applications

DRAGSTERDRIVE™ COG DRIVE - REVERSE ROTATION (INLET FACES FORWARD)

Part Number	Description	Price
4DD-BBC-1	Chevrolet Big Block F-3 DragsterDrive	\$3,999
4DD-SBC-1	Chevrolet Small Block F-3 DragsterDrive	\$3,999

specify	Hub Type (Splined, large shaft, or standard shaft)	specify
add "-ACC"	Dual Accessory Drive Standard Length (w/ pulleys, cog belt, & 2 x 3/8" hex drives)	\$949
add "-ACE"	Dual Accessory Drive Extended Length (w/ pulleys, cog belt, & 2 x 3/8" hex drives)	\$949
add "-ALT"	Alternator Drive (w/ Cog Belt)	\$799
PFG01A-xx	CrankDrive - add 1 Quick-Change Gear Set (specify 1.300, 1.353, 1.400, 1.450, 1.500, 1600, 1688, 1.789:1)	\$239
3PCCD-023	CrankDrive - Service Bag - Drive Bushing Hardware (Small Bushings, Large bushings & O-Rings)	\$199
DB712I-12	CrankDrive - Alternator Drive Belt	\$29
DB640I-020	CrankDrive - Standard Accessory Drive Belt	\$39
DB680I-020	CrankDrive - Extended Accessory Drive Belt	\$49

<i>CrankDrive, Reverse BeltDrive & DragsterDrive footnotes</i>	<p>Drive spacing is engine and component specific. Contact ProCharger Racing for specific balancer, degree wheel, crank trigger, crankshaft spacing and motorplate part number compatibility</p> <p>Optional Alternator Drive Requires GM CS121/CS130 6.14" Alternator</p> <p>Optional Accessory Drive: 50% reduction rate, V-Band 3/8 Hex, specify Standard or extended length drive option</p> <p>One set of Quick-Change Gears (or COG pulleys & belt) included with purchase, add 'l gears (or pulleys & belt) sets available, sold separately</p> <p>*SPECIFY: With or without motor plate; Standard or extended snout (RCD) Crankshaft</p>
--	--

SUPERCHARGERS

Part Number	Description	Price
PC066A-002	A-1P ProCharger (satin)	\$2,249
PC065A-002	A-1R ProCharger (satin)	\$2,249
PC064A-002	B-1 ProCharger (satin)	\$2,249
PC061A-001	C-1 ProCharger (satin)	\$2,599
PC061A-003	C-1R SC ProCharger (satin)	\$2,899
PC062A-001	C-2 ProCharger (satin)	\$2,899
PC061A-004	CS-1 ProCharger (Satin)	\$2,999
PC010A-002	P600B ProCharger (satin)	\$2,199
PC050A-001	P-1SC ProCharger (satin)	\$2,779
PC050A-040	P-1SC-1 ProCharger (satin)	\$2,999
PC050A-051	P-1SC-2 ProCharger (satin)	\$2,999
PC053A-040	P-1X ProCharger (satin)	\$3,199
PC041A-001	D-1 ProCharger (satin)	\$3,199
PC051A-001	D-1SC ProCharger (satin)	\$3,249
PC054A-001	D-1X ProCharger (satin)	\$3,424
PC323A-001	F-1D ProCharger (satin)	\$3,789
PC324A-001	F-1 ProCharger (satin)	\$3,789
PC325A-001	F-1A ProCharger (satin)	\$3,789
PC335A-001	F-1A-91 ProCharger (satin)	\$4,119
PC336A-001	F-1A-94 ProCharger (satin)	\$4,119
PC327A-001	F-1C ProCharger (satin)	\$4,119
PC326A-001	F-1R ProCharger (satin)	\$4,119
PC330A-001	F-1X ProCharger (satin)	\$5,299
PC328A-002	F-2 ProCharger (satin)	\$5,499
PC314A-102	F-3D-102 ProCharger (satin)	\$5,999
PC314A-106	F-3D-106 ProCharger (satin)	\$5,999
PC314A-112R	F-3R-112 (F-1X-12) ProCharger (Satin)	\$6,399
PC314A-121R	F-3R-121 ProCharger (satin)	\$6,699
PC314A-130	F-3R-130 ProCharger (satin)	\$6,999
PC314A-136	F-3R-136 ProCharger (satin)	\$7,199
PC314A-140-C-SP-T	F-3R-140 ProCharger (satin) with spline and threaded volute	\$9,249
PC316A-140-C-SP-T	F-3X-140 ProCharger (satin) with spline and threaded volute	\$9,449
PC318A-140-C-SP-T	F-4X-140 ProCharger (satin) with spline and threaded volute	\$11,249
PC318A-142-C-SP-T	F-4X-142 ProCharger (satin) with spline and threaded volute	TBD
PC314A-12A-RD	F-3R-112RD (F-1X-12RD) ProCharger Racedrive	\$9,999
PC314A-121-RD	F-3R-121RD ProCharger Racedrive	\$9,999
CALL	F-3R Threaded Volute w/ V-Band Clamp (New Head Unit builds)	\$200
CALL	F-3R Threaded Volute w/ Dual Seal Flange (New Head Unit builds)	\$200
CALL	F-3D/F-3R Splined Input Shaft Option	\$150
PC016A-001	Polished or Black Finish of (A, B, C, P, D, F-series) 7" or 9" Models (at time of purchase)	\$325
PC016A-002	Polished or Black Finish of (F-1C, F-1R) 9.75" Models (at time of purchase)	\$375
PC016A-003	Polished or Black Finish of (F-3D-, F-1X, F-2) 10.5" Models (at time of purchase)	\$475
PC016A-004	Polished or Black Finish of (F-3R-) 12" Models (at time of purchase)	\$575
PC016A-006	Polished Finish of RaceDrive Models (at time of purchase)	\$1,000

SUPERCHARGER UPGRADES

Part Number	Description	Price
CALL	P-1SC to D-1SC Upgrade (currently owned, satin finish)	\$1,399
CALL	P-1SC-1 to D-1SC Upgrade (currently owned, satin finish)	\$1,499
CALL	P-1SC to D-1X Upgrade (currently owned, satin finish)	\$1,499
CALL	P-1SC-1 to D-1X Upgrade (currently owned, satin finish)	\$1,724
CALL	P-1X to D-1X Upgrade (currently owned, satin finish)	\$1,724
CALL	F-1A to F-1A-94 Upgrade (currently owned, satin finish)	\$1,599
CALL	F-1A to F-1X Upgrade (currently owned, satin finish)	call
PC015A-009	Additional Charge for SC Upgrade if Polished or Black Finish	\$105
PC015A-001	SC Series Oil System Re-Clocking (currently owned)	call
PC015A-002	F1-F-2 Series Oil System Re-Clocking (currently owned)	call

SUPERCHARGER OIL AND RELATED HARDWARE

Part Number	Description	Price
ME001G-009	6 oz SC Oil Pack (12 bottles)	\$149
ME001G-001	6 oz SC Oil Pack (3 bottles)	\$42
ME001A-001	6 oz SC Oil Bottle (Single)	\$16
ME001G-004	4 oz SC Oil Pack (3 bottles)	\$39
ME001A-004	4 oz SC Oil Bottle (Single)	\$15
ME001G-002	2.5 oz SC Oil Pack (4 bottles)	\$39
ME001A-002	2.5 oz SC Oil Bottle (Single)	\$13
ME001G-003	3.2 oz i-1 Oil Pack (3 bottles)	\$38
ME001A-003	3.2 oz i-1 Oil Bottle (Single)	\$14
ME001G-050	CrankDrive & RaceDrive Gear Oil Pack (4 bottles 4 oz each)	\$24
3PCOL-002	Self-Contained Oil Drain Line Kit	\$69
3PCOL-004	Self-Contained Oil Drain Line Kit (w/ 90 fitting)	\$69
PCD01A-002	Drain Plug with Magnet	\$12
PDC04A-001	P-1SC Dipstick 7.13" Long	\$23
PDC04A-002	P-1SC Dipstick 9.5"	\$23
AB003A-096	F-1 / F-2 Front Cover Brace	\$59

PULLEYS, BELTS, AND DRIVE SYSTEM COMPONENTS

Part Number	Description	Price
3FADR-031	F-1 / F-2 Cog Pulley Hub Assembly (w/ hardware)	\$109
3FADR-033	F-3 / F-4 Cog Pulley Hub Assembly - Keyed Input Shaft (w/ hardware)	\$114
3FADR-034	F-3 / F-4 Cog Pulley Hub Assembly - Splined Input Shaft (w/ hardware)	\$450
DPxxxI-06D	6 Rib Drive Pulley	\$99
DPxxxI-08D	8 Rib Drive Pulley	\$109
DPxxxI-10D	10 Rib Drive Pulley	\$115
DPxxxI-12D	12 Rib Drive Pulley	\$119
DP050A-xxx	Cog Tooth Supercharger Pulley 8mm pitch x 50mm wide (hub required)	\$169
DP055A-xxx	Cog Tooth Supercharger Pulley 8mm pitch x 55mm extra wide (hub required)	\$174
DP075A-xxx	Cog Tooth Supercharger Flanged Pulley 8mm pitch x 75mm wide (hub required)	\$322
DP014A-xxx	Cog Tooth Supercharger Pulley 14mm pitch x 94mm extra wide	\$169
DBxxxI-006	6 Rib Serpentine Belt Gates (All Lengths)	\$59
DBxxxI-008	8 Rib Serpentine Belt Gates (All Lengths)	\$54
DBxxxI-010	10 Rib Serpentine Belt Gates/ATI (All Lengths)	\$84
DBxxxI-012	12 Rib Serpentine Belt Gates/ATI (All Lengths)	\$84
DBG-xxxxI	HD GREEN SERPENTINE BELT GATES/ATI (SELECT SIZES)	CALL
DB-xxxxI-RPM	HD RPM SERPENTINE BELT GATES/ATI (SELECT SIZES)	CALL
DBxxxxI-030	Cog Belt 30mm wide (carbon) (Stage II HEMI, high hp)	\$149
DBxxxxI-075XP	Cog Belt 75mm wide (Rubber) (8 mm Tooth Pitch)	\$179
DBxxxxI-50GT	Cog Belt 50mm wide (Rubber) (8 mm Tooth Pitch)	\$219
DBxxxxI-055	Cog Belt 55mm wide (Kevlar) (14 mm Tooth Pitch)	\$428
3GSMM-001	GM LS Crank Pinning Kit	\$99
3DEMM-001	Dodge Hemi LX Crank Pinning Kit	\$99
MD001I-003	Crank Pin	\$5

RACE BELLMOUTHS

Part Number	Description	Price
AF006A-026	Race Bellmouth - F-1 / F-1A / F-1D / F-1A-91	\$349
AF006A-025	Race Bellmouth - F-1A-94 / F-1C-94	\$349
AF006A-028	Race Bellmouth - F-1C / F-1R	\$359
AF006A-020	Race Bellmouth - F-1X / F-3D-102 / F-3D-104 / F-3D-106	\$399
AF006A-017	Race Bellmouth - F-2	\$399
AF006A-019	Race Bellmouth - F-3R-112 (F1X-12)	\$399
AF006A-018	Race Bellmouth - F-3R-121 (Requires machined volute)	\$399
AF006A-016	Race Bellmouth - F-3R-130 / F-3R-136 / F-3R-140	\$429
AF006A-027	Race Bellmouth - F-3X-140 / F-4X-140 / F-4X-142	\$479

AIR FILTERS

Part Number	Description	Price
AF006A-110	ProCharger Inlet Guard P-1SC, P-1SC-1, P-1X, D-1SC & D-1X models (3.75" inlet diameter)	\$105
AF006A-111	ProCharger Inlet Guard F-1A-94 & F-1R models (4.0" inlet diameter)	\$110
AF006A-112	ProCharger Inlet Guard F-1X / F-2 / F-3D models (4.75" inlet diameter)	\$115
AF056I-003	Air Filter RU-3480 4.5" inlet 6" long 5.875" base diameter	\$89
AF056I-004	Air Filter RU-3220 5" inlet 10" long 6.5" base diameter	\$99
AF056I-005	Air Filter RU-2590 4" inlet 7" long 5.375" base diameter	\$69
AF056I-007	Air Filter RU-3130 (3.5" inlet, 7" long, 4.625" base diameter)	\$69
AF056I-009	Air Filter RE-0920 (3.5" inlet, 9" long, 6" base diameter)	\$79
AF057I-001	Air Filter RE-0870 (4" inlet, 9" long, 6" diameter)	\$89
AF057I-004	Air Filter RU-0160 "Surge System Filter" (1.5" inlet, 4" long, 3" diameter)	\$49
AF059I-001	Steel Screen Race Filter	\$79

INTERCOOLER TUBING KITS

Part Number	Description	Price
AI004A-002	Universal Tubing Kit (2.5")	\$359
AI004A-003	Universal Tubing Kit (3")	\$369
AI004A-035	Universal Tubing Kit (3.5")	\$379
AI004A-004	Universal Tubing Kit (4")	\$997

SURGE VALVES

Part Number	Description	Price
AV008A-001	ProFlow Bypass /Anti-Surge Valve	\$244
AV006A-003	Bullet Bypass/Anti-Surge Valve - Closed	\$349
AV006A-004	Bullet Bypass/Anti-Surge Valve - Open	\$349
3FASS-004	Race Valve "OPEN" with Mounting Hardware (Alum. Flange) RED	\$469
3FASS-004B	Race Valve "OPEN" with Mounting Hardware (Alum. Flange) BLACK	\$469
3FASS-008	Race Valve "OPEN" with Mounting Hardware (Steel Flange) RED	\$469
3FASS-008B	Race Valve "OPEN" with Mounting Hardware (Steel Flange) BLACK	\$469
3FASS-003	Race Valve "ENCLOSED" with Mounting Hardware (Alum. Flange) RED	\$469
3FASS-003B	Race Valve "ENCLOSED" with Mounting Hardware (Alum. Flange) BLACK	\$469
3FASS-007	Race Valve "ENCLOSED" with Mounting Hardware (Steel Flange) RED	\$469
3FASS-007B	Race Valve "ENCLOSED" with Mounting Hardware (Steel Flange) BLACK	\$469
3FASS-023	Competition Valve "OPEN" With Mounting Hardware (5" Aluminum base) BLACK	\$499
3FASS-024	Competition Valve "OPEN" With Mounting Hardware (5" Aluminum base) RED	\$499
3FASS-009	Race Valve Vacuum Hardware (ProFlow to Race Valve)	\$64
3FASS-010	ProRace Valve "Open" with Mounting Hardware RED w/ Universal Base	\$699
3FASS-010B	ProRace Valve "Open" with Mounting Hardware BLACK w/ Universal Base	\$699
3FASS-018	ProRace Valve "Open" with Mounting Hardware RED w/ 4" Base	\$699
3FASS-018B	ProRace Valve "Open" with Mounting Hardware BLACK w/ 4" Base	\$699
3FASS-019	ProRace Valve "Open" with Mounting Hardware RED w/ 5" Base	\$699
3FASS-019B	ProRace Valve "Open" with Mounting Hardware BLACK w/ 5" Base	\$699
AV012I-017	ProRace Valve V-Band Flange for 4" Tube	\$99
AV012I-018	ProRace Valve V-Band Flange for 5" Tube	\$109
3FASS-005	Race Valve Mounting Flange / Tube (Steel)	\$59
3FASS-006	Race Valve Mounting Flange / Tube (Alum)	\$59

CARBURETOR BONNETS AND COMPONENTS

Part Number	Description	Price
AM001A-002P	Competition Carb Hat 4500 (5" Inlet, 5.5" Height Polished Finish)	\$419
AM001A-002B	Competition Carb Hat 4500 (5" Inlet, 5.5" Height Black Finish)	\$459
AM001A-001	Competition Carb Hat 4150 (3.5" Inlet, 4.5" Height Satin)	\$260
AM001A-001B	Competition Carb Hat 4150 (3.5" Inlet, 4.5" Height Black Finish)	\$350
AM001A-001P	Competition Carb Hat 4150 (3.5" Inlet, 4.5" Height Polished Finish)	\$350
AM009A-001	Standard Carb Hat 4150 (3.5" Inlet, 2.75" Height Satin)	\$219
AM009A-001B	Standard Carb Hat 4150 (3.5" Inlet, 2.75" Height Black Finish)	\$309
AM009A-001P	Standard Carb Hat 4150 (3.5" Inlet, 2.75" Height Polished Finish)	\$309
AM006A-001	Low Profile Carb Hat 4150 (3" Inlet, 2" Height Satin)	\$200
AM006A-001B	Low Profile Carb Hat 4150 (3" Inlet, 2" Height Black Finish)	\$290
AM006A-001P	Low Profile Carb Hat 4150 (3" Inlet, 2" Height Polished Finish)	\$290
AF006A-071	1" Billet Carb Cover Spacer (gasket seal)	\$44
AF006A-072	2" Billet Carb Cover Spacer (gasket seal)	\$54
AF006A-073	3" Billet Carb Cover Spacer (gasket seal)	\$69
AM001I-001	1" Billet Competition Carb Hat Spacer (O-ring seal)	\$110
AM001I-002	2" Billet Competition Carb Hat Spacer (O-ring seal)	\$115
AM001I-003	3" Billet Competition Carb Hat Spacer (O-ring seal)	\$120
AM001I-004	Competition Carb Hat O-Ring	\$6
AM006I-001	Thick Carb Cover Gasket 5 1/8" Diameter	\$9

FIELD UPGRADES

Part Number	Description	Price
2FWSU-001-6	Mustang GT (15-17) 6 Rib HO Shared To 8 Rib Stage II Dedicated Drive w/ Factory Balancer	\$1,299
tbd	Coyote Crank Support Gen 1	tbd
2FWSU-003	Coyote Crank Support Gen 2 & Gen 3 Satin finish	\$699
2FWSU-003B	Coyote Crank Support Gen 2 & Gen 3 Black Anodized finish	\$894
2FWSU-003P	Coyote Crank Support Gen 2 & Gen 3 Polished Finish	\$894
3FWDR-010	2015+ 8.00" Crank Pulley (For Innovators Balancer)	\$269
3FWDR-002	2015+ 8.00" Crank Pulley (For ATI balancer) kit built before 4/30/20	\$229
3FWDR-006	2018+ 7.65" Crank Pulley (For ATI balancer) kit built before 4/30/20	\$209
2KCSU-001	Corvette C8 Optional Port Injection Conversion Intake Manifold Base w/ Fuel Rails in Raw	CALL
2KUSU-001B	Corvette C8 Optional Port Injection Conversion Intake Manifold Base w/ Fuel Rails in Black	CALL
2KCSU-002B	Corvette C8 Carbon Fiber Engine Cover	CALL
2KCSU-003B	Corvette C8 Carbon Fiber Trunk Package	CALL
2GUSU-003	Corvette C7 LT1 Air To Water Field Upgrade	\$3,995
2GUSU-004	Corvette C7 8 Rib To 10 Rib Field Upgrade	\$699
2GUSU-002	Corvette C7 Z06 LT4 Air To Water Field Upgrade	\$2,350
2GUSU-005	Corvette C7 ProRace Air To Water Field Upgrade	call
2GUSU-004-Z	Corvette C7 Z06 8 Rib To 10 Rib Field Upgrade	\$699
2GQSU-001-6	Corvette C6 6 Rib HO To 8 Rib Stage II Dedicated Drive (Requires ATI Balancer)	\$1,555
2GQSU-001-8	Corvette C6 8 Rib HO To 8 Rib Stage II Dedicated Drive (Requires ATI Balancer)	\$925
2GQSU-002	Corvette C6 8 Rib HD Stage II Dedicated Drive To 10 RIB Upgrade (Requires ATI Balancer)	\$975
AIGO3A-003	Corvette C6 Race Intercooler (3.5" Inlet/Outlet Top/Side) 1300hp	\$1,350
AIGO3A-004	Corvette C6 Race Intercooler (4.0" Inlet/Outlet Top/Side) 1300hp	\$1,450
AIGO11-008	Corvette C6 Race Tube 4" (Intercooler to Intake)	\$199
2GYSU-001	Camaro 2016+ LT1 Air To Water Field Upgrade	\$3,995
2GYSU-003	Camaro 2016+ LT1 10 Rib Field Upgrade (requires ATI balancer, not supplied)	\$699
2GYSU-002	Camaro ZL1 2017+ LT4 Air To Water Field Upgrade	\$2,975
2GYSU-003	Camaro ZL1 2017+ LT4 10 Rib Field Upgrade (requires ATI balancer, not supplied)	\$699
2GUSU-001B	GM 2014+ LT1/LT4 Intake Manifold Black (with Black Cover & Hardware)	\$2,699
2GUSU-001	GM 2014+ LT1/LT4 Intake Manifold Raw (with Black Cover & Hardware)	\$2,499
2GUSU-001B-F	GM 2014+ LT1/LT4 Intake Manifold Black (with Black Cover & Hardware) W/ FUEL RAILS	\$3,199
2GUSU-001-F	GM 2014+ LT1/LT4 Intake Manifold Raw (with Black Cover & Hardware) W/ FUEL RAILS	\$2,999
1GJ115-IC	Camaro / Firebird (98-02) Race Intercooler field upgrade	\$1,699
AIDJ1A-011	Jeep SRT8 2006-10 Race Intercooler Upgrade	\$1,299
AIDL1A-019	Jeep SRT8 2012-15 Race Intercooler Upgrade	\$1,399

GAUGES

Part Number	Description	Price
MG001I-001	Boost Gauge (0- 20psi)	\$89
MG001I-005	Mech. 20 PSI Boost Gauge, 2-1/16", Black Face (Branded)	\$99
MG001I-008	Mech. 20 PSI Boost Gauge, 2-1/16", Silver Face (Branded)	\$99
MG001I-007	Elec. 30 PSI Fuel Pressure Gauge, 2-1/16", Silver Face (Branded)	\$259

FUEL SYSTEM COMPONENTS

Part Number	Description	Price
FI001A-1000	Injectors Set of 8 {1000CC, 95 LB/HR INJ} EV14	\$999
3DKMA-002	6.4L HEMI 2 bar MAP Sensor Adapter (W/ Sensor)	\$199
FV001I-BST	Boost Sensitive Fuel Pressure Regulator EFI / Carb	\$259
FV002I-BST	Boost Sensitive Fuel Pressure Regulator EFI / Carb (1000hp compatible)	\$279
FP001A-020	Universal Fuel Pump Voltage Booster Kit	\$425
FV001A-012	3.0" FMU Base Unit	\$259
FV001A-001	3.5" FMU Base Unit	\$279
FV001A-013	4.0" FMU Base Unit	\$289
FV001A-015	4.5" FMU Base Unit	\$299
GF012I-001	FMU Vacuum Signal Restrictor (.0185")	\$3

While you're on our website, show your ProCharger pride with a big selection of ProCharger apparel from T-shirts, to hats, license plate frames, gauges and more at ProCharger.com/store.

PROMOTIONAL ITEMS

Part Number	Description	Price
PS0121-001	Flag 60"w x 36"h "ProCharger Racing"	\$139
PS0111-001	Shop / Event Banner, Large, 36"h x 96"w, "ProCharger Racing"	\$49
PS0111-002	Shop / Event Banner, Small, 20"h x 48"w, "ProCharger Racing"	\$29
PS0061-003	ProCharger Metal Ink Pen	\$2
PS0021-072	ProCharger Can Cooler, Yellow/Black Reversible, Neoprene, Black Stitching, Full Color	\$4
PS0021-073	ProCharger Can Cooler, Blue/Yellow Reversible, Neoprene, Black Stitching, Full Color	\$4
PS0011-023	5" ProCharger Sticker (Black Printed on Silver Vinyl)	\$3
PS0011-041	ProCharger Racer Contingency Decal, 40 sq/in	\$3
PS0011-054	ProCharger Racer Contingency Decal, 70 sq/in	\$6
PS0021-001	License Plate Frame "Warning: Contents Under Pressure"	\$9
PS0021-002	License Plate Frame "Blown and Intercooled"	\$9
PS0021-003	License Plate Frame "ProCharger.com"	\$9
PS0021-004	White "ProCharger.com" License Frame	\$9

APPAREL

Part Number	Description	Price
MATS46	BEANIE - w POM PROCHARGER	\$15
MATS46-1	BEANIE - w/o POM PROCHARGER	\$15
MATS47	SCARF - PROCHARGER LOGO	\$20
MAHT01-001	MESH SNAPBACK HAT - CHAR/BLK, WHITE LOGO	\$25
MAHT01-002	MESH SNAPBACK HAT - BLK/BLK WHITE/SLVR LOGO	\$25
MATS45	GRAPHITE HOODIE - EAGLE	\$50
MATS42	BLACK HOODIE - SHIFTER RED WHITE BLUE	\$50
MATS21	BLACK HOODIE - YELLOW PROCHARGER LOGO	\$45
MATS07	BLACK LONG SLEEVE- GRAY PROCHARGER LOGO	\$22
MATS28	BLACK LONG SLEEVE- GRAY PROCHARGER LOGO (LEFT CHEST)	\$22
MASBSW	BLACK SHORT SLEEVE- GRAY PROCHARGER LOGO	\$20
MASBYW	BLACK SHORT SLEEVE- YELLOW PROCHARGER LOGO	\$20
MATS24	BLACK T-SHIRT-BELT/PULLEYS PROCHARGER	\$20
MATS25	WHITE T-SHIRT-BELT/PULLEYS PROCHARGER	\$20
MATS26	CHARCOAL T-SHIRT- USA FLAG PROCHARGER	\$20
MATS27	ROYAL BLUE T-SHIRT- USA FLAG PROCHARGER	\$20
MATS33	BLACK SHORT SLEEVE-WHITE TEXT PROCHARGER LOGO	\$20
MATS41	GRAY T-SHIRT - HEART OF A CHAMPION	\$20
MATS38	Ladies T Shirt PROCHARGER 94	\$20
MATS37	Ladies Tank Top - LOVE	\$20

**FIND MERCH AT
PROCHARGER.COM**



DIGITAL & PRINT

Make sure to check out the online versions of ProCharger's industry leading downloadable catalogs for whatever vehicle platform you have or are considering at ProCharger.com or give us a call and we can send you a physical version.



PRODUCT CATALOGS

Part Number	Description	Price
PS0051-006	Mustang Catalog	\$2.00
PS0051-001	Corvette Catalog	\$2.00
PS0051-007	GM Automotive Catalog	\$2.00
PS0051-002	Hemi Catalog	\$2.00
PS0051-009	Truck / SUV Catalog	\$2.00
PS0051-005	Carbureted Chevrolet Catalog	\$2.00
PS0051-004	Full Line Automotive and Truck/SUV Catalog	\$2.00
PS0051-010	Catalog Display Rack (displays up to 4 types)	\$129

ProCharger Office in
Mill Valley, California

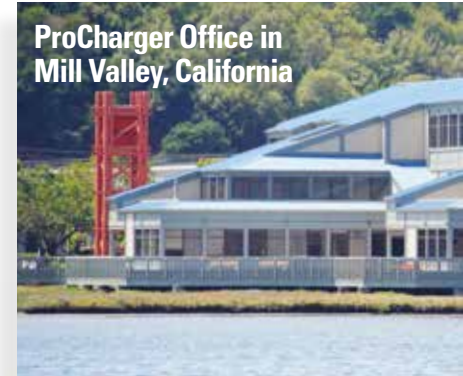

ProCharger Headquarters in
Kansas City





STREET, STRIP, SHOW AND TOW—PROCHARGER HAS YOU COVERED WITH
THE ULTIMATE POWER ADDER[®]

Follow Us On Social Media

Facebook: @prochargersuperchargers
Instagram: @prochargersuperchargers
Youtube: @prochargersuperchargers
Twitter: @procharger

Accessible Technologies, Inc / ProCharger

Sales/Service Phone Hours: 8:00 am–5:30 pm CST (M-F)
Sales Email Address: sales@procharger.com
Technical Service Email: ts@procharger.com
Customer Service Email: cs@procharger.com

