



Oils and Filters

This information provides specifications for Oil and Filters applications in MACK vehicles.

Note: We have attempted to cover as much information as possible. However, this information does not cover all the unique variations that a vehicle chassis may present. Note that illustrations are typical but may not reflect all the variations of assembly.

All data provided is based on information that was current at time of release. However, **this information is subject to change without notice.**

Please note that no part of this information may be reproduced, stored, or transmitted by any means without the express written permission of MACK Trucks, Inc.

Contents:

- “Oil and Filters”, page 2
- “Biodiesel Fuel”, page 6
- “Coolant Requirements”, page 7

Oil and Filters

MP7, MP8 and MP10 Engines

Engine	Oil Capacity
MP 7 and MP 8	44 quarts (42 L)
MP 10	55 quarts (52 L)

Approved Oils

For a complete list of Approved Oils used in Mack Engines, transmissions, and other components, refer to **Approved Oils, Mack Components.**

MP7, MP8, and MP10 (US 2010) Engine Oil Type / Quality

Engines meeting the 2010 and later emissions requirements are designed with exhaust aftertreatment systems requiring an oil that meets MACK EO-O Premium Plus quality standards for model year 2010 and later MACK engines. The MACK EO-O Premium Plus quality standard is based on the API CJ-4 engine oil specification, but has additional performance requirements essential to adequately protect the MACK engines at the drain intervals specified. Pre-2010 engines also work better with the recommended engine oils. They are not required, but are strongly recommended.

Recommended SAE Grades For Engines
Mack Bulldog EO-O and Mack Bulldog Premium Plus EO-O
10W-30, 15W-40



CAUTION

Extra oil additives must never be added to any engine oil used.

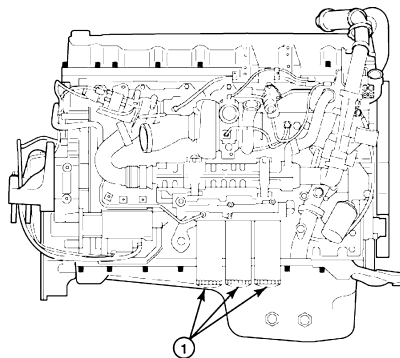

W2055691

1 Typical Spin-On Oil Filter (MP8 Engine Shown)

Rear Axle Oil Viscosity

The following chart indicates the recommended rear axle oil weights.

Recommended SAE Grades for Rear Axles		
GO-J – Mineral Base	GO-J Plus – Synthetic Base	TO-A Plus – Synthetic
SAE 80W-90, 80W-140, 85W-140	SAE 75W-85, 75W-90, 75W-110, 75W-140, 80W-140	SAE 50

Rear Axle Oil Capacity

MACK rear axle capacity ranges from 34 US pints (16.1 liters) to 36 US pints (17 liters), depending on the axle model.

Transmission, Lubrication

T300 Series Manual Transmission Oil

Use only MACK-approved mineral or synthetic transmission oil in the T300 Series manual transmissions. The capacity of the transmission ranges from 20 US qts (9.5 liters) to 30 US qts (14.2 liters), depending on the specific T300 transmission model and the number of gears used. At this time, GO- J, GO-J Plus and TO-A Plus specification oils are acceptable transmission oil types. However, either GO-J Plus or TO-A Plus Synthetic is required for extended oil change intervals.

Recommended SAE Grades (All Temperatures, All Manual Transmissions)		
GO-J – Mineral Base	GO-J Plus – Synthetic Base	TO-A Plus – Synthetic
SAE 80W-90, 80W-140, 85W-140	SAE 75W-85, 75W-90, 75W-110, 75W-140, 80W-140	SAE 50

Check *mDrive* Transmission Oil Level

Check the *mDrive* transmission oil level at each service interval. To do so, park the vehicle on a level surface and check the transmission oil level through the sight glass on the right side of the transmission. Add MACK-approved synthetic transmission oil as needed. Note that the drain plug indicates the type of oil used in the transmission.

Silver Drain Plug	SAE50 <i>mDrive</i> Heavy Duty
Brass Drain Plug	75W-80 <i>mDrive</i> Standard

Recommended SAE Grades for <i>mDrive</i> Transmissions
Mack Synthetic Gearbox Oil
75W-80, SAE50

Mack Oil Types and Part Numbers

Oil Weight	Part Number and Alternative
SAE50	85146531 or Mobile Delvac Synthetic Transmission Oil V50
75W-80	9853-120551 or Mobile Delvac Synthetic Transmission Oil V30

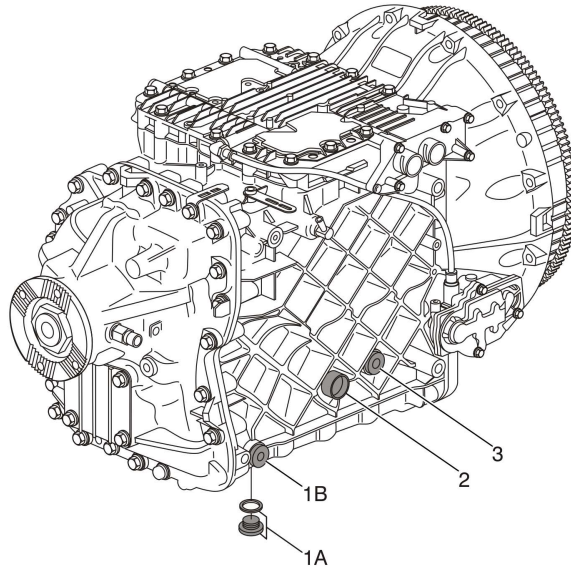

W4002904

- 1A Drain Plug
- 1B Drain Port
- 2 Sight Glass
- 3 Fill Plug and Oil Level

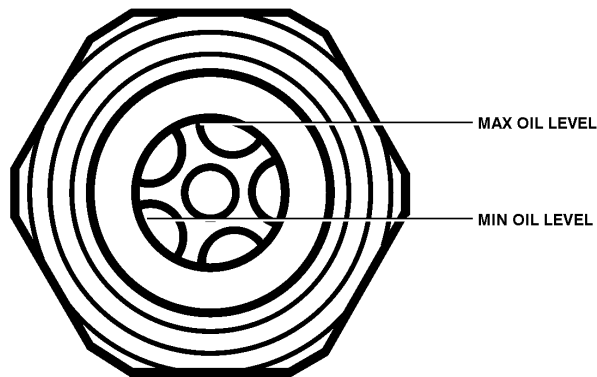

T4021684

Sight Glass for Checking Transmission Oil Level

mDrive Lubrication Capacity

Transmission	Oil Type	Capacity Including Cooler
mDrive – MACK		
TmD12	Refer to the approved oils list (SB 175–61)	17.9 quarts
TmD13 / TmD14	Refer to the approved oils list (SB 175–61)	20.5 quarts

Fuel Ventilation

Fuel Tank Ventilation Filter

Some vehicles are equipped with a fuel tank ventilation filter. This filter must accompany the fuel tank if the tank is relocated.

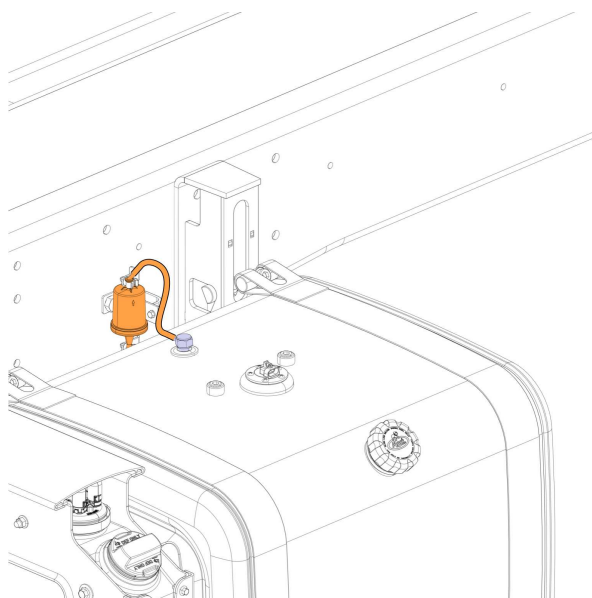

W2085894

Frame Rail-Mounted Filter

Notes

Biodiesel Fuel

Description

There is a trend in the trucking industry toward the use of biodiesel fuel; a processed fuel derived from renewable biological resources such as vegetable oil. The most common such fuel available in the United States is derived from soybean oil (a product called "Soy Methyl Ester" [SME or SOME]). In its pure form, biodiesel fuel is designated B100 (or "Neat Biodiesel"), which means that the fuel is 100% biodiesel. The 100% product is then blended with petroleum-based Ultra Low Sulfur Diesel (ULSD) fuel in concentrations of 2% biodiesel to 98% petroleum-based diesel, 5% biodiesel to 95% petroleum-based diesel, 20% biodiesel to 80% petroleum-based diesel, and higher. The resultant biodiesel fuel blends are then designated as B2 (for a 2% blend), B5 (for a 5% blend), B20 (for a 20% blend) and so on.

Biodiesel Emissions

MACK MP7, MP8 and MP10 engines are certified to comply with U.S. EPA and California emissions standards based upon the use of test fuels with specifications established by these regulatory agencies.

Alternative fuels, including biodiesel, that are not substantially similar to the required test fuels may adversely affect engine emissions compliance. As a result, MACK does not warrant the engine will conform to applicable Federal or California emissions limits when operated on biodiesel or other alternative fuels that are not substantially similar to specified test fuels used for certification.

Warranty Policy

The engine warranty covers defects in material and workmanship on the part of the manufacturer. Failures caused by fuel are not warrantable. Refer to the Warranty Certificate in the vehicle operator's manual for complete details on engine and emission systems warranty coverage including limitations and exclusions.

However, the use of biodiesel up to a maximum of 20% (B20) in and of itself, will not affect the manufacturer's mechanical warranty as to engine and emissions system related components, provided the biofuel used in the blend conforms to ASTM D6751, B1 to B5 blends conform to ASTM D975, and B6 to B20 blends conform to ASTM D7467.

Please note that engine and aftertreatment emissions system component warranties are valid providing the B20 blend meets the respective ASTM standard.

Greenhouse Gas 2017 Emissions (GHG17)

For 2017 GHG emissions the maximum allowable limit of biodiesel is B10 (10% blend).

ASTM Standards

The American Society for Testing and Materials (ASTM) standard D6751 defines B100. Any B100 product used in the manufacture of the blend intended for use in a MACK vehicle must conform to the ASTM D 6751 standard.

ASTM standard D975 defines the minimum accepted values for the properties of petroleum-based diesel fuel. Any petroleum-based diesel fuel used in a MACK vehicle, either alone or when blended with B100 for the maximum approved concentration (up to B5), must meet the ASTM D975 standard.

Certified Biodiesel Required

The National Biodiesel Accreditation Commission conducts quality certification and accreditation programs for producers and marketers of biodiesel products. The B100 used in the approved blend must be produced by a BQ-9000 Accredited Producer and the blend must be supplied by a Certified Marketer.

Storage of Biodiesel

The standard storage and handling procedures used for petroleum-based diesel fuel apply to biodiesel (reference the operator's manual for information concerning the handling and storing of diesel fuel). Compared to petroleum-based diesel fuel, biodiesel fuel has lower oxidation stability and there are greater concerns for water contamination and microbial growth. Biodiesel should be stored in a clean, dry, dark environment. Acceptable storage tank materials include aluminum, steel, fluorinated polyethylene, fluorinated polypropylene or Teflon®. Storage containers which contain copper, brass, lead, tin or zinc should not be used to store petroleum-based diesel nor biodiesel. Use of such containers will result in corrosion of the container and contamination of the fuel. Every effort should be taken to make sure that the biodiesel product is used within six months of the date of manufacture.

Coolant Requirements

Chevron Delo ELC

Currently, Mack Trucks utilizes the Chevron Delo ELC (Extended Life Coolant) at its Macungie, PA plant facility as its premium coolant. This coolant is manufactured by and purchased from Chevron Products Company. Please be advised that the Texaco ELC Coolant and Chevron Delo ELC Coolant brands are the same product and suitable for all Mack vehicles that come factory filled with the Chevron Delo ELC (red) Coolant. In addition, the Chevron Delo ELC Coolant and Texaco ELC brand coolant meet the same Mack Truck warranty requirements.

Coolant

Regular Coolant

Standard Factory Fill Color: Purple (Pink)

Coolant Type	A 50/50 mixture of clean water and Antifreeze that meets or exceeds ASTM D6210 or TMC RP329. ASTM D6210: Standard Specification for Fully-Formulated Ethylene-Glycol-Base Engine Coolant for Heavy-Duty Engines. Note: A coolant mixture should never have less than 40% antifreeze and 60% clean water.
Coolant Change Interval	Replace the coolant every 250,000 miles (400 000 km) or 4000 hours or every two years, whichever comes first.
Coolant Filter Change Interval	The coolant filter is suitable for 50,000 miles (80 500 km) . The charged coolant filter contains eight units of SCA that are released slowly over time to maintain the recommended level during operation. If the SCA level tests above 3.0, DO NOT replace the coolant filter. When testing indicates that the SCA level has dropped below 1.5 units per US gallon (0.4 unit per liter) start changing the filter with the oil changes again.
(SCA) Test Cycle	Coolant SCA level must be tested at least twice a year and whenever coolant loss occurs. For maximum cooling system efficiency, test the system every 25,000 to 35,000 miles (40,000 to 56,000 km) depending on oil change interval or every 1000 hours or every 6 months (whichever comes first).
(SCA) Test Kit	Fleetguard® CC2602 3-Way™ Heavy Duty Test Kit.
(SCA) Type	Fleetguard® DCA 4 or Nalcool
(SCA) level	Between 1.5 and 3.0 SCA units per gallon (0.4 and 0.8 units per liter) of coolant.
Cooling System Capacities	Approximately 50 liters (53 US quarts) with a manual transmission For an automatic transmission, add 9.5 liters (10 quarts)

Extended Life Coolant (ELC)

(Optional) Color: Red

Coolant Type	ELC Antifreeze is a single-phase, ethylene glycol type heavy duty diesel engine coolant/antifreeze. ELC must meet or exceed ASTM D6210 or TMC RP 329 for heavy-duty diesel service.
Coolant Change Interval	Replace coolant every 750,000 miles (1 275 000 km) or every 15,000 hours or every eight years, whichever comes first. A one-time ELC extender package must be added to the cooling system after 500,000 miles (850 000 km) or 10,000 hours or four years, to allow for Extended Coolant Service Life up to 1,000,000 miles (1 700 000 km) or 20,000 hours or eight years.
Coolant Filter Change Interval	When using ELC Antifreeze, use a coolant filter that does not contain SCAs. Replace filter every 150,000 miles (240 000 km) or 2500 hours or 15 months, whichever comes first, to prevent external rusting of the can). For vendor engines, refer to each manufacturer for information.
Coolant Testing	The slow depleting additive chemistry does not require regular testing, but the coolant can be tested with a FleetFix Maintenance Test Strip and the FleetFix Dilution Test Kit. The FleetFix Maintenance Test Strip (a measure for nitrite and carboxylate levels, while the FleetFix Dilution Test Kit can determine contamination of ELC and continued protection levels. The freeze protection level should be checked at least twice per year with a standard refractometer. -35°F (-2°C) is the freeze point of approximately 50/50 ELC coolant.

Extended Service Coolant (E/S)

(Optional) Color: Blue

FleetGuard E/S Compleat

Coolant Type	E/S Antifreeze /Coolants are Extended Life formulations that contain Ethylene Glycol base fluids and are designed specifically for Extended Service use in heavy-duty diesel engines. ES COMPLETEAT contains conventional heavy-duty chemical inhibitors and eliminates hard water scale deposits.
Coolant and Filter Change Interval	When using E/S Antifreeze, use a coolant filter with ES slow release coolant filters or liquid ES extender to provide simplified coolant maintenance while extending coolant service intervals to 12 months or 150,000 miles. ES COMPLETEAT can also be used in standard coolant service intervals with the use of SCA's and standard coolant filters. Replace filter every 150,000 miles (240,000 km) or 2500 hours or 12 months, whichever comes first, to prevent external rusting of the can). For vendor engines, refer to each manufacturer for information.
(SCA) Test Cycle	Coolant SCA level must be tested at least twice a year and whenever coolant loss occurs. For maximum cooling system efficiency, test the system every 35,000 miles (40,000 to 56,000 km) depending on oil change interval or every 1000 hours or every 6 months (whichever comes first). For more details refer to the coolant manufacturer's guidelines.

E/S Compleat is a trademark of FleetGuard®.

Water Specifications

Water Specifications	Parts per million (ppm)	Grains per Gallon	pH	µS/cm	mg/KmnO4/l
Chlorides, maximum	< 40	< 2.34			
Sulfates, maximum	< 100	< 5.8			
Total dissolved solids, maximum	< 340	< 20			
Total hardness	< 170	< 10			
pH			5.5-9		
Silica	< 20	< 1.17			
Iron	< 0.10	< 0.0058			
Manganese	< 0.05	< 0.0029			
Conductivity				< 500	
CODMn					< 15

Notes

Coolant

Note: DO NOT mix different coolant products, such as regular antifreeze and extended life antifreeze, etc.

Coolant Requirements

Mack Trucks recommends the use of low silicate ethylene glycol base coolant for heavy duty engines. This coolant must meet or exceed ASTM D6210 or TMC RP329.

Mack does not recommend the use of antifreeze based on propylene glycol.

There are two types of coolants recommended for the Mack engines. One type requires the addition of **SCAs** (Supplemental Coolant Additives) to maintain the desired properties of the coolant.

The other type uses no SCAs. This type of coolant is often referred to as **ELC** (Extended Life Coolant).

Note: The two types of coolant are not to be mixed since this would have negative effects on the coolant's properties.

Note: Antifreeze or premixed coolant meeting the standards ASTM D3306 or ASTM D4656 are primarily for automotive gasoline engines, containing high levels of silicate, and are unacceptable for heavy duty diesel engines. The silicates will clog the radiator and leave unwanted deposits in the engine.

Notes
