

C Brake by Jacobs

E Brake by Jacobs

Application Guide



E BRAKE
by Jacobs

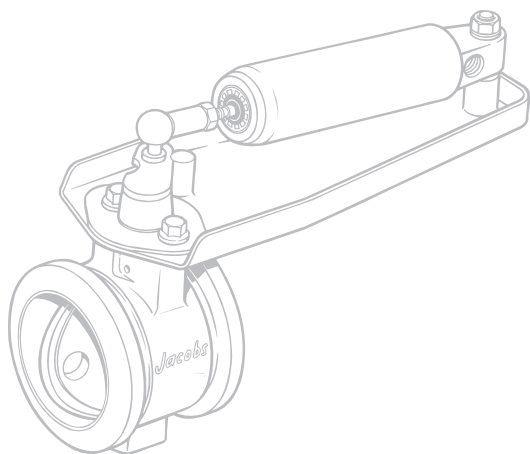

C BRAKE
By Jacobs

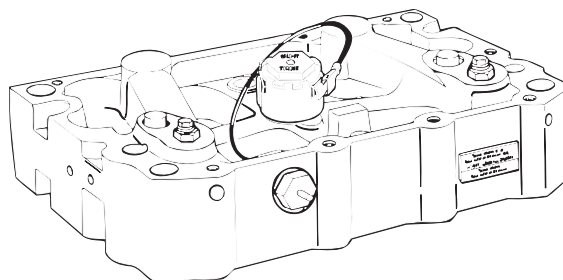

TUNE - UP KITS

Engine Brake Model	Part Number
25B/30/30E/400/400H	3871418
401A/401B/401C	3871535
420/425	3871536
425A	3871537
430	3871538
404/404B	3871540
440/440A, 450A/450B	3871568
404D/411/411C/411D/411E	3871580
404BG	3871586
455A/455B/455C	3871704
490/490A	3800917
Upgrade Kit, Model 404B TO 404BG	3871513

(Guided Crossheads to Guideless Crossheads)

SERVICE TOOLS

Description	Part Number
Tool Kit (includes all adjustment gauges)	3871523
Adjustment Gage 0.015"	3871428
Adjustment Gage 0.018"	3871272
Adjustment Gage 0.021"	3871435
Adjustment Gage 0.023"	3871534
Adjustment Gage 0.024"	3871467
Adjustment Gage 0.027"	3133172
Adjustment Gage 0.030"	3871451
Adjustment Gage 0.037"	3871452
Adjustment Gage 0.040"	3871471
Adjustment Gage 0.046"	3871470
Adjustment Gage 0.090"	3163681
Slave piston removal tool	3871654
Oil Pressure Test Kit	3871551
Grinding Gage 425A	3871221

(for grinding exhaust rockers on engines built before 1980)

Engine Brake Applications

CPL No.	CPL No.	Old CPL No.	Engine Model	Engine Brake		Slave Lash	12V Base Kit	24V SL Base Kit	24V DL Base Kit	Engine Control Group		Cab Control Group	Original / Compatible Brakes		Orig. Slave Lash	
				Brake	Lash					Control Group	Control Group		Control Group	Control Group	Control Group	Control Group
8792			ISL07	490A	0.090"	4089626	N/A	N/A	N/A	N/A	See p.16 for Application Information					
8786			ISC07	490A	0.090"	4089626	N/A	N/A	N/A	N/A	See p.16 for Application Information					
8780			ISL98	490	0.090"	4089653	N/A	N/A	N/A	N/A	See p.16 for Application Information					
8718			ISL98	490	0.090"	4089653	N/A	N/A	N/A	N/A	See p.16 for Application Information					
8717			ISL98	490	0.090"	4089653	N/A	N/A	N/A	N/A	See p.16 for Application Information					
8706			ISM02	411D	0.015"	4089395	N/A	N/A	N/A	N/A	3871669					
8703			ISL98	490	0.090"	4089653	N/A	N/A	N/A	N/A	See p.16 for Application Information					
8662			ISL98	490	0.090"	4089653	N/A	N/A	N/A	N/A	See p.16 for Application Information					
8651			ISL98	490	0.090"	4089653	N/A	N/A	N/A	N/A	See p.16 for Application Information					
8650			ISL98	490	0.090"	4089653	N/A	N/A	N/A	N/A	See p.16 for Application Information					
8648			ISL98	490	0.090"	4089653	N/A	N/A	N/A	N/A	See p.16 for Application Information					
8647			ISL98	490	0.090"	4089653	N/A	N/A	N/A	N/A	See p.16 for Application Information					
8646			ISL98	490	0.090"	4089653	N/A	N/A	N/A	N/A	See p.16 for Application Information					
8643			ISL98	490	0.090"	4089653	N/A	N/A	N/A	N/A	See p.16 for Application Information					
8641			ISL98	490	0.090"	4089653	N/A	N/A	N/A	N/A	See p.16 for Application Information					
8608			QSM11-CE	411C	0.015"	3800765	N/A	N/A	N/A	N/A	3871669					
8600			ISL98	490	0.090"	4089653	N/A	N/A	N/A	N/A	See p.16 for Application Information					
8548			ISL98	490	0.090"	4089653	N/A	N/A	N/A	N/A	See p.16 for Application Information					
8547			ISL98	490	0.090"	4089653	N/A	N/A	N/A	N/A	See p.16 for Application Information					
8608			QSM11-CE	411C	0.015"	3800765	N/A	N/A	N/A	N/A	3871669					
8603			ISM02	411D	0.015"	4089395	N/A	N/A	N/A	N/A	3871669					
8600			ISL98	490	0.090"	4089653	N/A	N/A	N/A	N/A	See p.16 for Application Information					
8572			ISM02	411D	0.015"	4089395	N/A	N/A	N/A	N/A	3871669					
8563			ISM02	411D	0.015"	4089395	N/A	N/A	N/A	N/A	3871669					
8562			ISM02	411D	0.015"	4089395	N/A	N/A	N/A	N/A	3871669					
8561			ISM02	411D	0.015"	4089395	N/A	N/A	N/A	N/A	3871669					
8560			ISM02	411D	0.015"	4089395	N/A	N/A	N/A	N/A	3871669					
8559			ISM02	411D	0.015"	4089395	N/A	N/A	N/A	N/A	3871669					
8558			ISM02	411D	0.015"	4089395	N/A	N/A	N/A	N/A	3871669					
8557			ISM02	411D	0.015"	4089395	N/A	N/A	N/A	N/A	3871669					
8556			ISM02	411D	0.015"	4089395	N/A	N/A	N/A	N/A	3871669					
8548			ISL98	490	0.090"	4089653	N/A	N/A	N/A	N/A	See p.16 for Application Information					
8547			ISL98	490	0.090"	4089653	N/A	N/A	N/A	N/A	See p.16 for Application Information					

* Additional harness is required for this installation - 3871653 (Ground Harness)

CPL No.	Old CPL No.	Engine Model	Engine Brake	Slave Lash	12V Base Kit	24V SL Base Kit	24V DL Base Kit	Engine Control Group	Cab Control Group	Original / Compatible Brakes	Orig. Slave Lash
8546		QSM11-CE	411C	0.015"	3800765	N/A	N/A	N/A	3871669		
8545		QSM11-CE	411C	0.015"	3800765	N/A	N/A	N/A	3871669		
8544		QSM11-CE	411C	0.015"	3800765	N/A	N/A	N/A	3871669		
8543		QSM11-CE	411C	0.015"	3800765	N/A	N/A	N/A	3871669		
8506		ISM02	411D	0.015"	4089395	N/A	N/A	N/A	3871669		
8505		ISM02	411D	0.015"	4089395	N/A	N/A	N/A	3871669		
8504		ISM02	411D	0.015"	4089395	N/A	N/A	N/A	3871669		
8503		ISM02	411D	0.015"	4089395	N/A	N/A	N/A	3871669		
8495		QSM11-CE	411C	0.015"	3800765	N/A	N/A	N/A	3871669		
8476		ISL03	490A	0.090"	4089626	N/A	N/A	N/A	See p.16 for Application Information		
8475		ISL03	490A	0.090"	4089626	N/A	N/A	N/A	See p.16 for Application Information		
8474		ISL03	490A	0.090"	4089626	N/A	N/A	N/A	See p.16 for Application Information		
8473		ISL03	490A	0.090"	4089626	N/A	N/A	N/A	See p.16 for Application Information		
8471		QSM11-CE	411C	0.015"	3800765	N/A	N/A	N/A	3871669		
8458		ISL03	490A	0.090"	4089626	N/A	N/A	N/A	See p.16 for Application Information		
8427		ISM02	411D	0.015"	4089395	N/A	N/A	N/A	3871669		
8409		QSM11-CE	411C	0.015"	3800765	N/A	N/A	N/A	3871669		
8377		ISM02	411D	0.015"	4089395	N/A	N/A	N/A	3871669		
8389		ISL03	490A	0.090"	4089626	N/A	N/A	N/A	See p.16 for Application Information		
8309		ISM02	411D	0.015"	4089395	N/A	N/A	N/A	3871669		
8271		ISM02	411D	0.015"	4089395	N/A	N/A	N/A	3871669		
8221		ISL03	490A	0.090"	4089626	N/A	N/A	N/A	See p.16 for Application Information		
8158		ISL	490	0.090"	4089653	N/A	N/A	N/A	See p.16 for Application Information		
8106		ISL	490	0.090"	4089653	N/A	N/A	N/A	See p.16 for Application Information		
8042		ISL	490	0.090"	4089653	N/A	N/A	N/A	See p.16 for Application Information		
2946		ISL	490	0.090"	4089653	N/A	N/A	N/A	See p.16 for Application Information		
2830		ISM 425	411C	0.015"	3800765	N/A	N/A	N/A	3871669		
2829		QSM11-CE	411C	0.015"	3800765	N/A	N/A	N/A	3871669		
2828		QSM11-CE	411C	0.015"	3800765	N/A	N/A	N/A	3871669		
2812		ISM 425	411C	0.015"	3800765	N/A	N/A	N/A	3871669		
2809		ISM 425	411C	0.015"	3800765	N/A	N/A	N/A	3871669		
2731		ISM07	411E	0.027"	4955458	N/A	N/A	N/A	N/R		
2730		ISM07	411E	0.027"	4955458	N/A	N/A	N/A	N/R		
2729		ISM07	411E	0.027"	4955458	N/A	N/A	N/A	N/R		
2728		ISM07	411E	0.027"	4955458	N/A	N/A	N/A	N/R		
2727		ISM07	411E	0.027"	4955458	N/A	N/A	N/A	N/R		
2614		ISM	411C	0.015"	3800765	N/A	N/A	N/A	3871669		

CPL No.	Old CPL No.	Engine Model	Engine Brake	Slave Lash	12V Base Kit	24V SL Base Kit	24V DL Base Kit	Engine Control Group	Cab Control Group	Original / Compatible Brakes	Orig. Slave Lash
2612		ISM	411C	0.015"	3800765	N/A	N/A	N/A	3871669		
2611		ISM	411C	0.015"	3800765	N/A	N/A	N/A	3871669		
2610		ISM	411C	0.015"	3800765	N/A	N/A	N/A	3871669		
2608		ISM 425	411C	0.015"	3800765	N/A	N/A	N/A	3871669		
2607		ISM 280-330	411C	0.015"	3800765	N/A	N/A	N/A	3871669		
2592		N14 NE3	455B	0.023"	3804603	3804604	3804665	3871652	3871647		
2591		N14 NE2	455B	0.023"	3804603	3804604	3804665	3871652	3871647		
2590		N14 NE1	455C	0.023"	3411467	N/A	3411468	3871652	3871647		
2576		ISM	411C	0.015"	3800765	N/A	N/A	N/A	3871669		
2563		ISM	411C	0.015"	3800765	N/A	N/A	N/A	3871669		
2562		ISM	411C	0.015"	3800765	N/A	N/A	N/A	3871669		
2543		ISM 405	411C	0.015"	3800765	N/A	N/A	N/A	3871669		
2542		ISM 380	411C	0.015"	3800765	N/A	N/A	N/A	3871669		
2541		ISM 340	411C	0.015"	3800765	N/A	N/A	N/A	3871669		
2540		ISM 305 ESP	411C	0.015"	3800765	N/A	N/A	N/A	3871669		
2539		ISM 305	411C	0.015"	3800765	N/A	N/A	N/A	3871669		
2477		ISM	411C	0.015"	3800765	N/A	N/A	N/A	3871669		
2475		ISL	490	0.090"	4089653	N/A	N/A	N/A	See p.16 for Application Information		
2459		L10	404BG	0.015"	3804575	3804576	N/A	N/R	N/R		
2445		M11	411	0.015"	3804584	3804585	3804586	3871658	3871669		
2425		M11-330 E Plus/280 E Plus	411	0.015"	3804584	3804585	3804586	3871658	3871669		
2398		N14 370 - 460 E Plus	455B	0.023"	3804603	3804604	3804665	3871652	3871647		
2391		N14-435 ESP Plus (435-525 E PLUS)	455B	0.023"	3804603	3804604	3804665	3871652	3871647		
2390		N14-370 ESP Plus (370-460 E PLUS)	455B	0.023"	3804603	3804604	3804665	3871652	3871647		
2389		N14-330 ESP Plus (330-425 E PLUS)	455C	0.023"	3411467	N/A	3411468	3871652	3871647		
2385		LTA10-C	411	0.015"	3804584	3804585	3804586	3871658	3871669		
2371		M11 350-370 ESP PLUS (330-450 E PLUS), (335 V)	411	0.015"	3804584	3804585	3804586	3871658	3871669		
2370		M11 280-330 ESP PLUS (280-350 E PLUS), (305/335 V)	411	0.015"	3804584	3804585	3804586	3871658	3871669		
2350		425 hp ISM	411C	0.015"	3800765	N/A	N/A	N/A	3871669		
2210		ISM	411C	0.015"	3800765	N/A	N/A	N/A	3871669		
2200		>330 hp ISM	411C	0.015"	3800765	N/A	N/A	N/A	3871669		
2199		<330 hp ISM	411C	0.015"	3800765	N/A	N/A	N/A	3871669		
2192		LTA10-C	411	0.015"	3804584	3804585	3804586	3871658	3871669		

CPL No.	Old CPL No.	Engine Model	Engine Brake	Slave Lash	12V Base Kit	24V SL Base Kit	24V DL Base Kit	Engine Control Group	Cab Control Group	Original / Compatible Brakes	Orig. Slave Lash
2178		M11 Plus 420 - 450 HP	411	0.015"	3804584	3804585	3804586	3871658	3871669		
2143		N14 EURO II	455B	0.023"	N/A	N/A	3804665	3871652*	3871647		
2141		M11 Plus 280 - 330 HP	411	0.015"	3804584	3804585	3804586	3871658	3871669		
2140		M11 Plus 280 - 330 HP	411	0.015"	3804584	3804585	3804586	3871658	3871669		
2119		MTA11-C300	404D	0.015"	3804581	3804582	3804583	3871525	3883602		
2099		M11 305 (Bus)	411	0.015"	N/A	N/A	3804586	3080422	3255804		
2097		M113 350	411	0.015"	N/A	N/A	3804586	3080422	3255804		
2087		ISL07	490A	0.090"	4089626	N/A	N/A	N/A	See p.16 for Application Information		
2085		ISC07	490A	0.090"	4089626	N/A	N/A	N/A	See p.16 for Application Information		
2068		L10 325 STC	404D	0.015"	N/A	N/A	3804580	3871531	3883602		
2067		L10-280E	404D	0.015"	3804581	3804582	3804583	3871525	3883602		
2066		L10-280E	404D	0.015"	3804581	3804582	3804583	3871525	3883602		
2042		M11 305 ESP	411	0.015"	N/A	N/A	3804586	3080422	3255804		
2040		M11 280/330/340	411	0.015"	N/A	N/A	3804586	3080422	3255804		
2037		M11 Plus 330 - 400 HP	411	0.015"	3804584	3804585	3804586	3871658	3871669		
2036		M11 Plus 280 - 330 HP	411	0.015"	3804584	3804585	3804586	3871658	3871669		
2027		N14-330 ESP Plus (310E - 370E)	55B	0.023"	3804603	3804604	3804665	3871652	3871647		
2026		N14-370 ESP Plus (410E - 500E)	455B	0.023"	3804603	3804604	3804665	3871652	3871647		
2025		N14-435 ESP Plus (435E - 525E)	455B	0.023"	3804603	3804604	3804665	3871652	3871647		
2003		N14 500E	450B	0.023"	3804597	3804598	3804599	3074287	3871661		
1994		LTA10-B	404BG	0.015"	3804575	3804576	N/A	N/R	N/R		
1991		M11 370E	411	0.015"	3804584	3804585	3804586	3080422	3883216		
1987		N14-350E (310E - 370E)	450A	0.023"	3804594	3804595	3804596	3074287	3871661		
1973		M11-400	411	0.015"	3804584	3804585	3804586	3080422	3883216		
1957	1405	N14-410/STC	440	0.023"	3804591	N/A	3804592	3871542	3871543		
1956	1374	N14-370/STC	440	0.023"	3804591	N/A	3804592	3871542	3871543		
1954	1373	91L10-260/STC	404D	0.015"	3804581	3804582	3804583	3871525	3883602		
1953	1362	91L10-280/STC	404D	0.015"	3804581	3804582	3804583	3871525	3883602		
1952	1349	91L10-310/STC	404D	0.015"	3804581	3804582	3804583	3871525	3883602		
1951	1241	91L10/STC	404D	0.015"	3804581	3804582	3804583	3871525	3883602		
1946		M11 - 370E	411	0.015"	3804584	3804585	3804586	3080422	3883216		
1944		N14 430E,460E	440A	0.023"	3804593	N/A	N/A	3074287	3871541		
1933		LTA10-C	411	0.015"	3804584	3804585	3804586	3871658	3871669		
1931		LTA10-C	411	0.015"	3804584	3804585	3804586	3871658	3871669		
1930		LTA10-C	411	0.015"	3804584	3804585	3804586	3871658	3871669		
1913	1448	91L10-260/STC	404D	0.015"	3804581	3804582	3804583	3871525	3883602		

* CAUTION! DO NOT use former model 445 on CPL's 1580, 1583, 1611, or 1831. Serious engine damage will result. Use only Model 440 on these engines.

CPL No.	Old CPL No.	Engine Model	Engine Brake	Slave Lash	12V Base Kit	24V SL Base Kit	24V DL Base Kit	Engine Control Group	Cab Control Group	Original / Compatible Brakes	Orig. Slave Lash
1912	1450	91L10/STC	404D	0.015"	3804581	3804582	3804583	3871525	3883602		
1911	1447	91L10-280/STC	404D	0.015"	3804581	3804582	3804583	3871525	3883602		
1910	1449	91L10/STC	404D	0.015"	3804581	3804582	3804583	3871525	3883602		
1909	1446	91L10-310/STC	404D	0.015"	3804581	3804582	3804583	3871525	3883602		
1897		MTA11-C330/C350	404D	0.015"	3804581	3804582	3804583	3871525	3883602		
1896		94 N14	450B	0.023"	3804597	3804598	3804599	3074287	3871661		
1894		LTA10-C	411	0.015"	3804584	3804585	3804586	3871658	3871669		
1885		M11-400	411	0.015"	3804584	3804585	3804586	3080422	3883216		
1878		N14-430	440*	0.023"	3804591	N/A	3804592	3074287	3871541		
1877		LTA10-C	411	0.015"	3804584	3804585	3804586	3871658	3871669		
1875		M11-280	411	0.015"	3804584	3804585	3804586	3080422	3883216		
1871		L10/STC	404D	0.015"	3804581	3804582	3804583	3871525	3883602		
1870		L10/STC	404D	0.015"	3804581	3804582	3804583	3871525	3883602		
1869		L10/STC	404D	0.015"	3804581	3804582	3804583	3871525	3883602		
1868		L10/STC	404D	0.015"	3804581	3804582	3804583	3871525	3883602		
1867		L10/STC	404D	0.015"	3804581	3804582	3804583	3871525	3883602		
1866		L10/STC	404D	0.015"	3804581	3804582	3804583	3871525	3883602		
1857		M11 ESP II	411	0.015"	3804584	3804585	3804586	3080422	3883216		
1856		M11-330/370E	411	0.015"	3804584	3804585	3804586	3080422	3883216		
1855		M11-280/330E	411	0.015"	N/A	N/A	3804586	3080422	3255804		
1852		94 N14	450B	0.023"	3804597	3804598	3804599	3074287	3871661		
1849		91L10	404BG/D	0.015"	3804578	3804579	3804580	N/R	N/R		
1844		94 N14	450B	0.023"	3804597	3804598	3804599	3074287	3871661		
1833		N14-330E/350E	450A	0.023"	3804594	3804595	3804596	3074287	3871661		
1831		N14-430E/460/E	440*	0.023"	3804591	N/A	3804592	3074287	3871541		
1809		94 N14	450B	0.023"	3804597	3804598	3804599	3074287	3871661		
1807		94 N14	450A	0.023"	3804594	3804595	3804596	3074287	3871661		
1699		M11	411	0.015"	3804584	3804585	3804586	3871658	3871669		
1686		NTAA 340 STC	430	0.046"	N/A	N/A	3267479	3871423	3042594		
1676		L10 325 STC	404BG/D	0.015"	3804578	3804579	3804580	N/R	N/R		
1675		91L10	404BG/D	0.015"	3804578	3804579	3804580	N/R	N/R		
1674		91L10	404BG/D	0.015"	3804578	3804579	3804580	N/R	N/R		
1669		L10-350	404D	0.015"	3804581	3804582	3804583	3892598	3883216		
1660		91L10	404BG/D	0.015"	3804578	3804579	3804580	N/R	N/R		
1652		N14-430/STC	440	0.023"	3804591	N/A	3804592	3871542	3871543		
1644		L10	404D	0.015"	3804581	3804582	3804583	3892598	3883216		
1642		L10-280	404D	0.015"	3804581	3804582	3804583	3892598	3883216		
1637		NTAA-410	430	0.046"	3804590	N/A	N/A	N/R	N/R		
1636		NTAA 380 STC	430	0.046"	N/A	N/A	3267479	3871423	3042594		

* CAUTION! DO NOT use former model 445 on CPLs 1580, 1583, 1611, or 1831. Serious engine damage will result. Use only Model 440 on these engines.

CPL No.	Old CPL No.	Engine Model	Engine Brake	Slave Lash	12V Base Kit	24V SL Base Kit	24V DL Base Kit	Engine Control Group	Cab Control Group	Original / Compatible Brakes	Orig. Slave Lash
1626		91L10	404BG/D	0.015"	3804578	3804579	3804580	N/R	N/R		
1625	1442	LTA10-350/STC	404BG	0.015"	3804575	3804576	N/A	N/R	N/R		
1624	1441	LTA10-B/STC	404BG	0.015"	3804575	3804576	N/A	N/R	N/R		
1623	1346	LTA10/STC	404BG	0.015"	3804575	3804576	N/A	N/R	N/R		
1622	1226	LTA10-B/STC	404BG	0.015"	3804575	3804576	N/A	N/R	N/R		
1621	1225	LTA10/STC	404BG	0.015"	3804575	3804576	N/A	N/R	N/R		
1620	1224	LTA10/STC	404BG	0.015"	3804575	3804576	N/A	N/R	N/R		
1619	1223	LTA10/STC	404BG	0.015"	3804575	3804576	N/A	N/R	N/R		
1617		L10-280	404D	0.015"	3804581	3804582	3804583	3892598	3883216		
1611		N14-500/E	440*	0.023"	3804591	N/A	3804592	3074287	3871541		
1609		LTA10-350E	404D	0.015"	3804581	3804582	3804583	3892598	3883216		
1607		N14-370/410	440*	0.023"	3804591	N/A	3804592	3074287	3871541		
1590		L10-280	404D	0.015"	3804581	3804582	3804583	3892598	3883216		
1589		L10-330	404D	0.015"	3804581	3804582	3804583	3892598	3883216		
1588	1513	L10-330	404D	0.015"	3804581	3804582	3804583	3892598	3883216		
1587		L10-330	404D	0.015"	3804581	3804582	3804583	3892598	3883216		
1583		N14-430/E	440*	0.023"	3804591	N/A	3804592	3074287	3871541		
1580		N14-430E/460/E	440*	0.023"	3804591	N/A	3804592	3074287	3871541		
1575		N14-480E	440A	0.023"	3804593	N/A	N/A	3074287	3871541		
1574		N14-310/E	440A	0.023"	3804593	N/A	N/A	3074287	3871541		
1573		N14-430/E	440A	0.023"	3804593	N/A	N/A	3074287	3871541		
1572		N14-460/E	440A	0.023"	3804593	N/A	N/A	3074287	3871541		
1562		L10-260/STC	404D	0.015"	3804581	3804582	3804583	3871525	3883602		
1560		L10-280/STC	404D	0.015"	3804581	3804582	3804583	3871525	3883602		
1558		L10-310/STC	404D	0.015"	3804581	3804582	3804583	3871525	3883602		
1556		ISM07	411E	0.027"	4955458	N/A	N/A	N/A	N/R		
1548		N140460E	440A	0.023"	3804593	N/A	N/A	3074287	3871541		
1545		ISM07	411E	0.027"	4955458	N/A	N/A	N/A	N/R		
1540		N14-330/E	440A	0.023"	3804593	N/A	N/A	3074287	3871541		
1538		N14-310/E	440A	0.023"	3804593	N/A	N/A	3074287	3871541		
1537		N14-330/E	440A	0.023"	3804593	N/A	N/A	3074287	3871541		
1536		N14-330/E	440A	0.023"	3804593	N/A	N/A	3074287	3871541		
1535		N14-350/E	440A	0.023"	3804593	N/A	N/A	3074287	3871541		
1534		N14-370/E	440A	0.023"	3804593	N/A	N/A	3074287	3871541		
1533		N14-370/E	440A	0.023"	3804593	N/A	N/A	3074287	3871541		
1532		N14-330/STC	440	0.023"	3804591	N/A	3804592	3871542	3871543		
1531		ISM07	411E	0.027"	4955458	N/A	N/A	N/A	N/R		
1530		N14-350/STC	440	0.023"	3804591	N/A	3804592	3871542	3871543		

*Compatible Models include 25A, 25B, 30, 30E, 401C & 400 only

CPL No.	Old CPL No.	Engine Model	Engine		Slave Lash	12V		24V SL		24V DL		Engine Control		Cab Control		Original / Compatible		Orig. Slave Lash
			Brake	Lash		Base Kit	Base Kit	Base Kit	Base Kit	Group	Group	Control Group	Control Group	Brakes	Brakes			
1529		N14-350/STC	440	0.023"	3804591	N/A	3804592	3871542	3871543									
1514		91L10-310	404D	0.015"	3804581	3804582	3804583	3892598	3883216									
1512		91L10-330	404D	0.015"	3804581	3804582	3804583	3892598	3883216									
1511		91L10-280	404D	0.015"	3804581	3804582	3804583	3892598	3883216									
1507		N14-370/STC See CPL 1374	440	0.023"	3804591	N/A	3804592	3871542	3871543									
1500		ISM07	411E	0.027"	4955458	N/A	N/A	N/A	N/R									
1450		91L10/STC See CPL 1912	404D	0.015"	3804581	3804582	3804583	3871525	3883602									
1449		91L10/STC See CPL 1910	404D	0.015"	3804581	3804582	3804583	3871525	3883602									
1448	1373	91L10-260/STC See CPL 1913	404D	0.015"	3804581	3804582	3804583	3871525	3883602									
1447	1362	91L10-280/STC See CPL 1911	404D	0.015"	3804581	3804582	3804583	3871525	3883602									
1446		91L10-310/STC See CPL 1909	404D	0.015"	3804581	3804582	3804583	3871525	3883602									
1445		N14-370/E	440A	0.023"	3804593	N/A	N/A	3074287	3871541									
1442		LTA10-350/STC, see CPL 1625	404BG	0.015"	3804575	3804576	N/A	N/R	N/R									
1441		LTA10-B/STC, See CPL1624,1994	404BG	0.015"	3804575	3804576	N/A	N/R	N/R									
1426		N14-410/E	440A	0.023"	3804593	N/A	N/A	3074287	3871541									
1414		91L10	404BG/D	0.015"	3804578	3804579	3804580	N/R	N/R									
1413		91L10	404BG/D	0.015"	3804578	3804579	3804580	N/R	N/R									
1412		91L10	404BG/D	0.015"	3804578	3804579	3804580	N/R	N/R									
1405		N14-410/STC, see CPL1957	440	0.023"	3804591	N/A	3804592	3871542	3871543									
1402		NTAA 410 STC	425A	0.037"	N/A	N/A	3804589	3871423	3042594									
1395		N14-330/STC	440	0.023"	3804591	N/A	3804592	3871542	3871543									
1394		N14-310/E	440A	0.023"	3804593	N/A	N/A	3074287	3871541									
1393		N14-330/E	440A	0.023"	3804593	N/A	N/A	3074287	3871541									
1392		N14-330/E	440A	0.023"	3804593	N/A	N/A	3074287	3871541									
1391		N14-350/E	440A	0.023"	3804593	N/A	N/A	3074287	3871541									
1390		N14-370/E	440A	0.023"	3804593	N/A	N/A	3074287	3871541									
1389		N14-370/E	440A	0.023"	3804593	N/A	N/A	3074287	3871541									
1386		N14-430/E	440A	0.023"	3804593	N/A	N/A	3074287	3871541									
1385		N14-430/E	440A	0.023"	3804593	N/A	N/A	3074287	3871541									
1384		N14-460/E	440A	0.023"	3804593	N/A	N/A	3074287	3871541									
1380		N14-350/STC	440	0.023"	3804591	N/A	3804592	3871542	3871543									
1378		LTA10-330/STC	404BG	0.015"	3804575	3804576	N/A	N/R	N/R									
1375		91L10	404D	0.015"	3804581	3804582	3804583	3892598	3883216									
1374		N14-330/STC See CPL 1507	440	0.023"	3804591	N/A	3804592	3871542	3871543									
1373		91L10/260/280/310 STC	404D	0.015"	N/A	N/A	3804580	3871531	3883602									
1370		NTAA 465 STC	425A	0.037"	N/A	N/A	3804589	3871423	3042594									
1367		91L10-310	404D	0.015"	3804581	3804582	3804583	3892598	3883216									

*Compatible Models include 25A, 25B, 30, 30E, 401C & 400 only

CPL No.	Old CPL No.	Engine Model	Engine Brake	Slave Lash	24V SL Base Kit	24V DL Base Kit	Engine Control Group	Cab Control Group	Original / Compatible Brakes	Orig. Slave Lash
1362		91L10/260/280/310 STC	404D	0.015"	N/A	3804580	3871531	3883602		
1359		LT10-225/STC	404BG	0.015"	3804576	N/A	N/R	N/R		
1352		FLEET300/88NT	430	0.024"	N/A	N/A	N/R	N/R		
1349		91L10/260/280/310 STC	404D	0.015"	N/A	3804580	3871531	3883602		
1348		91L10-330	404D	0.015"	3804582	3804583	3892598	3883216		
1347		91L10-310	404D	0.015"	3804581	3804583	3892598	3883216		
1346		LTA10 See CPL 1623	404BG	0.015"	3804575	N/A	N/R	N/R		
1324		N14-460E	440A	0.023"	3804593	N/A	3074287	3871541		
1286		NTC444/88NT	430	0.046"	3804590	N/A	N/R	N/R		
1285		NTC444/88NT	430	0.046"	3804590	N/A	N/R	N/R		
1280		NTC444/88NT	430	0.046"	3804590	N/A	N/R	N/R		
1256		NTC444/88NT	430	0.046"	3804590	N/A	N/R	N/R		
1226		LTA10 See CPL 1622,1994	404BG	0.015"	3804575	N/A	N/R	N/R		
1225	980	LTA10 See CPL 1621	404BG	0.015"	3804575	N/A	N/R	N/R		
1224	956	LTA10 See CPL 1620	404BG	0.015"	3804575	N/A	N/R	N/R		
1223	939	LTA10 See CPL 1619	404BG	0.015"	3804575	N/A	N/R	N/R		
1215		NTC444NBCIV	425A	0.037"	3804587	3804589	N/R	N/R	420	0.018"
1211		NTC400/88NTSTC	430	0.046"	3804590	N/A	N/R	N/R		
1210		NTC444/88NTSTC	430	0.046"	3804590	N/A	N/R	N/R		
1200		NTA 405 STC	425A	0.037"	N/A	3804589	3871423	3042594		
1199		NTE 365 F/T	430	0.032"	N/A	3267479	3871423	3042594		
1198		Pre91L10 F/T	404BG	0.015"	N/A	3804577	3871426	3871329		
1188		NTC350/88NTSTC	430	0.046"	3804590	N/A	N/R	N/R		
1187		FLEET 285/88NT	430	0.024"	3804590	N/A	N/R	N/R		
1186		NTE465/88NT	430	0.030"	3804590	N/A	N/R	N/R		
1185		NTC400/88NT	430	0.046"	3804590	N/A	N/R	N/R		
1161		91L10-330	404D	0.015"	3804581	3804583	3892598	3883216		
996		LTA10-B/STC	404BG	0.015"	3804575	N/A	N/R	N/R		
992		NT350E/88NT	430	0.030"	3804590	N/A	N/R	N/R		
974		NTC400/365BCIV	425A	0.018"	3804587	3804589	N/R	N/R	420	0.018"
915		ISL07	490A	0.090"	4089626	N/A	N/A	See p.16 for Application Information		
911		NT315-E	430	0.030"	3804590	N/A	N/R	N/R		
910		NTC444/88NT	430	0.046"	3804590	N/A	N/R	N/R		
909		NTA855	425A	0.030"	3804587	3804589	N/R	N/R		
907		NTC300BCIV	425A	0.018"	3804587	3804589	N/R	N/R	401C/400	0.021"
905		NTC300/320BCIV	425A	0.018"	3804587	3804589	N/R	N/R	401C/400	0.021"
904		NTC365/400NBCIV	425A	0.037"	3804587	3804589	N/R	N/R	420	0.018"
903		NTC444NBCIV	425A	0.037"	3804587	3804589	N/R	N/R	420	0.018"
891		NTC400BCIII	425A	0.018"	3804587	3804589	N/R	N/R	401B/400H	0.018"

*Compatible Models include 25A, 25B, 30, 30E, 401C & 400 only

CPL No.	Old CPL No.	Engine Model	Engine Brake	Slave Lash	12V Base Kit	24V SL Base Kit	24V DL Base Kit	Engine Control Group	Cab Control Group	Original / Compatible Brakes	Orig. Slave Lash
840		NTC350/88NT	430	0.024"	3804590	N/A	N/A	N/R	N/R		
838		NTC315/88NT	430	0.024"	3804590	N/A	N/A	N/R	N/R		
835	783	LTA10	404BG	0.015"	3804575	3804576	N/A	N/R	N/R		
833		NTC365/400NBCIV	425A	0.037"	3804587	3804588	3804589	N/R	N/R	420	0.018"
832		NTC300NBCIV	425A	0.018"	3804587	3804588	3804589	N/R	N/R	401C/400	0.021"
827		NTC400/88NT	430	0.046"	3804590	N/A	N/A	N/R	N/R		
821		NTC444BCIVSTC	425A	0.037"	3804587	3804588	3804589	N/R	N/R	420	0.018"
814		NTC400BCIV	425A	0.018"	3804587	3804588	3804589	N/R	N/R	401B/400H	0.018"
813		NTC350BCIV	425A	0.018"	3804587	3804588	3804589	N/R	N/R	401B/400H	0.018"
812		NTC315BCIV	425A	0.018"	3804587	3804588	3804589	N/R	N/R	401B/400H	0.018"
811		NTC300BCIV	425A	0.018"	3804587	3804588	3804589	N/R	N/R	401B/400H	0.018"
806		NTCC365/400STC	425A	0.037"	3804587	3804588	3804589	N/R	N/R	420	0.018"
797		NTC350NBCIV	425A	0.018"	3804587	3804588	3804589	N/R	N/R	401C/400	0.021"
796		NTC315NBCIV	425A	0.018"	3804587	3804588	3804589	N/R	N/R	401C/400	0.021"
795		NTCC350BCIVMVT	425A	0.018"	3804587	3804588	3804589	N/R	N/R	401B/400H	0.018"
794		NTCC315BCIVMVT	425A	0.018"	3804587	3804588	3804589	N/R	N/R	401B/400H	0.018"
790	764	LTA-10 (OAC)	404BG	0.015"	3804575	3804576	N/A	N/R	N/R		
789	748	LTA-10 (OAC)	404BG	0.015"	3804575	3804576	N/A	N/R	N/R		
787	726	LTA-10 (OAC)	404BG	0.015"	3804575	3804576	N/A	N/R	N/R		
786	708	LTA-10 (OAC)	404BG	0.015"	3804575	3804576	N/A	N/R	N/R		
785	671	LTA-10 (OAC)	404BG	0.015"	3804575	3804576	N/A	N/R	N/R		
780		LTA -10	404BG	0.015"	3804575	3804576	N/A	N/R	N/R		
778	641	LTA-10-270/320	404BG	0.015"	3804575	3804576	N/A	N/R	N/R		
777	528	LTA10 See CPL 1994	404BG	0.015"	3804575	3804576	N/A	N/R	N/R		
776		LTA 10/225	404BG	0.015"	N/A	N/A	3804577	3871426	3781329		
774		LTA10 See CPL 1994	404BG	0.015"	3804575	3804576	N/A	N/R	N/R		
773		LTA10-290	404BG	0.015"	3804575	3804576	N/A	N/R	N/R		
770		LT10-250	404BG	0.015"	3804575	3804576	N/A	N/R	N/R		
769		NTC350BCIII	425A	0.018"	3804587	3804588	3804589	N/R	N/R	401B/400H	0.018"
749		NTC315BCIV	425A	0.018"	3804587	3804588	3804589	N/R	N/R	401B/400H	0.018"
745		NTC400BCIII	425A	0.018"	3804587	3804588	3804589	N/R	N/R	401B/400H	0.018"
744		NTC350	425A	0.018"	3804587	3804588	3804589	N/R	N/R	401B	0.018"
743		NTC300	425A	0.018"	3804587	3804588	3804589	N/R	N/R	401B	0.018"
718		FLEET 300BCIV	425A	0.018"	3804587	3804588	3804589	N/R	N/R	401B/400H	0.018"
695		NTC400SC	425A	0.018"	3804587	3804588	3804589	N/R	N/R	25B*	0.018"
676		NTC400BCIV	425A	0.030"	3804587	3804588	3804589	N/R	N/R	401C/400	0.018"
675		NTC350BCIV	425A	0.030"	3804587	3804588	3804589	N/R	N/R	401C/400	0.018"
674		NTC300BCIV	425A	0.030"	3804587	3804588	3804589	N/R	N/R	401C/400	0.018"

*Compatible Models include 25A, 25B, 30, 30E, 401C & 400 only

CPL No.	Old CPL No.	Engine Model	Engine Brake	Slave Lash	12V Base Kit	24V SL Base Kit	24V DL Base Kit	Engine Control Group	Cab Control Group	Original / Compatible Brakes	Orig. Slave Lash
673		FLEET 300BCIV	425A	0.018"	3804587	3804588	3804589	N/R	N/R	401B/400H	0.018"
669		NTC350	425A	0.030"	3804587	3804588	3804589	N/R	N/R	401C/400	0.018"
659		NTAA-STC	425A	0.018"	N/A	N/A	3804589	3871423	3042594		
652		LTA 10	404BG	0.015"	3804575	3804576	N/A	N/R	N/R		
651		NTE400	425A	0.018"	3804587	3804588	3804589	N/R	N/R	401B/400H	0.018"
647		NTC320	425A	0.018"	3804587	3804588	3804589	N/R	N/R	401B/400H	0.018"
642		NTC400BCIV	425A	0.030"	3804587	3804588	3804589	N/R	N/R	401C/400	0.018"
638		LTA-10	404BG	0.015"	3804575	3804576	N/R	N/R	N/R		
637		NTC350BCII	425A	0.030"	3804587	3804588	3804589	N/R	N/R	401C/400	0.018"
636		NTC300SC	425A	0.037"	3804587	3804588	3804589	N/R	N/R	25B*	0.018"
635		NTC475BCIII	425A	0.018"	3804587	3804588	3804589	N/R	N/R	401B/400H	0.018"
634		FLEET 300BCIII	425A	0.018"	3804587	3804588	3804589	N/R	N/R	401B/400H	0.018"
633		NTC300BCIII	425A	0.018"	3804587	3804588	3804589	N/R	N/R	401B/400H	0.018"
632		NTC350BCIII	425A	0.018"	3804587	3804588	3804589	N/R	N/R	401B/400H	0.018"
625		NTC400BCIII	425A	0.018"	3804587	3804588	3804589	N/R	N/R	401B/400H	0.018"
617		NTCC240BCIIIIMVT	425A	0.018"	3804587	3804588	3804589	N/R	N/R	401B/400H	0.018"
616		NTCC300BCIIIIMVT	425A	0.018"	3804587	3804588	3804589	N/R	N/R	401B/400H	0.018"
615		NTCC350BCIIIIMVT	425A	0.018"	3804587	3804588	3804589	N/R	N/R	401B/400H	0.018"
614		NTCC400BCIIIIMVT	425A	0.018"	3804587	3804588	3804589	N/R	N/R	401B/400H	0.018"
612		NTC270BCIII	425A	0.030"	3804587	3804588	3804589	N/R	N/R	401C/400	0.018"
611		NTC350	425A	0.030"	3804587	3804588	3804589	N/R	N/R	401C/400	0.018"
606		FLEET 300BCIII	425A	0.030"	3804587	3804588	3804589	N/R	N/R	401C/400	0.018"
588		NTC400BCIII	425A	0.037"	3804587	3804588	3804589	N/R	N/R	401C/400	0.018"
586		NTC475BCIII	425A	0.018"	3804587	3804588	3804589	N/R	N/R	401B/400H	0.018"
585		NTC300BCIII	425A	0.030"	3804587	3804588	3804589	N/R	N/R	401C/400	0.018"
581		FLEET 270BCIII	425A	0.030"	3804587	3804588	3804589	N/R	N/R	401C/400	0.018"
579		NTC270BCIII	425A	0.030"	3804587	3804588	3804589	N/R	N/R	401C/400	0.018"
578		NTE290BCIII	425A	0.018"	3804587	3804588	3804589	N/R	N/R	401B/400H	0.018"
572		NTC350SC	425A	0.037"	3804587	3804588	3804589	N/R	N/R	25B*	0.018"
558		NTCC-240BCIII	425A	0.037"	3804587	3804588	3804589	N/R	N/R	25B*	0.018"
547		PT270SC	425A	0.037"	3804587	3804588	3804589	N/R	N/R	25B*	0.018"
543		NTC350BCII	425A	0.030"	3804587	3804588	3804589	N/R	N/R	401C/400	0.018"
536		NTC300BCII	425A	0.030"	3804587	3804588	3804589	N/R	N/R	401C/400	0.018"
531		NTC400BCIII	425A	0.018"	3804587	3804588	3804589	N/R	N/R	401B/400H	0.018"
530		NTC350BCIII	425A	0.030"	3804587	3804588	3804589	N/R	N/R	401C/400	0.018"
529		NTC300BCIII	425A	0.030"	3804587	3804588	3804589	N/R	N/R	401C/400	0.018"
518		NTC475BCII	425A	0.018"	3804587	3804588	3804589	N/R	N/R	401B/400H	0.018"
516		NTC350BCII	425A	0.030"	3804587	3804588	3804589	N/R	N/R	401C/400	0.018"
510		NTC400BCII	425A	0.030"	3804587	3804588	3804589	N/R	N/R	401C/400	0.018"

*Compatible Models include 25A, 25B, 30, 30E, 401C & 400 only

CPL No.	Old CPL No.	Engine Model	Engine Brake		Slave Lash		12V		24V SL		24V DL		Engine Control Group		Cab Control Group		Original / Compatible Brakes		Orig. Slave Lash	
			Brake	Lash	Base Kit	Base Kit	Base Kit	Base Kit	Base Kit	Base Kit	Base Kit	Base Kit	Base Kit	Base Kit	Control Group	Control Group	Control Group	Control Group	Control Group	Control Group
509		NTC350BCII	425A	0.030"	3804587	3804588	3804589	N/R	N/R	401C/400	401C/400	0.018"	0.018"							
506		FLEET 270BCII	425A	0.030"	3804587	3804588	3804589	N/R	N/R	401C/400	401C/400	0.018"	0.018"							
500		NTE 370 or 400 F/T	425A	0.018"	N/A	N/A	3871423	3042594												
499		NT855-C250	425A	0.030"	3804587	3804588	3804589	N/R	N/R	25B*	25B*	0.018"	0.018"							
498		PT240BCIII(EXT)	425A	0.030"	3804587	3804588	3804589	N/R	N/R	25B*	25B*	0.018"	0.018"							
497		NTC240BCIII(EXT)	425A	0.030"	3804587	3804588	3804589	N/R	N/R	401C/400	401C/400	0.018"	0.018"							
492		NTC270BCII	425A	0.030"	3804587	3804588	3804589	N/R	N/R	401C/400	401C/400	0.018"	0.018"							
491		PT270BCII	425A	0.030"	3804587	3804588	3804589	N/R	N/R	401C/400	401C/400	0.018"	0.018"							
488		NTC230SC	425A	0.037"	3804587	3804588	3804589	N/R	N/R	25B*	25B*	0.018"	0.018"							
485		NTC300BCII	425A	0.030"	3804587	3804588	3804589	N/R	N/R	401C/400	401C/400	0.018"	0.018"							
483		NTC350BCII	425A	0.030"	3804587	3804588	3804589	N/R	N/R	401C/400	401C/400	0.018"	0.018"							
482		NTC350BCII	425A	0.030"	3804587	3804588	3804589	N/R	N/R	401C/400	401C/400	0.018"	0.018"							
481		NTC400BCII	425A	0.030"	3804587	3804588	3804589	N/R	N/R	401C/400	401C/400	0.018"	0.018"							
473		NTC290BCII	425A	0.030"	3804587	3804588	3804589	N/R	N/R	401C/400	401C/400	0.018"	0.018"							
471		NTC300BCII	425A	0.030"	3804587	3804588	3804589	N/R	N/R	401C/400	401C/400	0.018"	0.018"							
459		NTCC300BCIIMVT	425A	0.018"	3804587	3804588	3804589	N/R	N/R	401C/400	401C/400	0.018"	0.018"							
458		NTCC350BCIIMVT	425A	0.018"	3804587	3804588	3804589	N/R	N/R	401C/400	401C/400	0.018"	0.018"							
457		NTCC400BCIIMVT	425A	0.018"	3804587	3804588	3804589	N/R	N/R	401C/400	401C/400	0.018"	0.018"							
456		NTCC300BCIIMVT	425A	0.018"	3804587	3804588	3804589	N/R	N/R	401C/400	401C/400	0.018"	0.018"							
455		NTCC350BCIIMVT	425A	0.018"	3804587	3804588	3804589	N/R	N/R	401C/400	401C/400	0.018"	0.018"							
454		NTCC400BCIIMVT	425A	0.018"	3804587	3804588	3804589	N/R	N/R	401C/400	401C/400	0.018"	0.018"							
450		NTC350BCII	425A	0.030"	3804587	3804588	3804589	N/R	N/R	30E*/400	30E*/400	0.018"	0.018"							
449		NTC400BCII	425A	0.037"	3804587	3804588	3804589	N/R	N/R	30E*/400	30E*/400	0.018"	0.018"							
437		NT240SC	425A	0.018"	3804587	3804588	3804589	N/R	N/R	401B/400H	401B/400H	0.018"	0.018"							
435		NTE 370 or 400 F/T	425A	0.018"	N/A	N/A	3871423	3042594												
433		NTC300BCII	425A	0.030"	3804587	3804588	3804589	N/R	N/R	30E*/400	30E*/400	0.018"	0.018"							
424		ISL07	490A	0.090"	4089626	N/A	N/A	See p.16 for Application Information												
419		NTE 350 F/T	425A	0.018"	N/A	N/A	3871423	3042594												
414		NTC300BCII	425A	0.030"	3804587	3804588	3804589	N/R	N/R	30E*/400	30E*/400	0.018"	0.018"							
408		NTCC230SC	425A	0.037"	3804587	3804588	3804589	N/R	N/R	25B*	25B*	0.018"	0.018"							
407		NTC230SC	425A	0.037"	3804587	3804588	3804589	N/R	N/R	25B*	25B*	0.018"	0.018"							
402		NTC290BCII	425A	0.030"	3804587	3804588	3804589	N/R	N/R	30E*	30E*	0.018"	0.018"							
393		NTC400BCI	425A	0.037"	3804587	3804588	3804589	N/R	N/R	30*	30*	0.018"	0.018"							
392		NTE350BCII	425A	0.018"	3804587	3804588	3804589	N/R	N/R	401B/400H	401B/400H	0.018"	0.018"							
391		NTE370BCII	425A	0.018"	3804587	3804588	3804589	N/R	N/R	401B/400H	401B/400H	0.018"	0.018"							
384		NTC350SC	425A	0.037"	3804587	3804588	3804589	N/R	N/R	25B*	25B*	0.018"	0.018"							
380		NTCC290BCI	425A	0.030"	3804587	3804588	3804589	N/R	N/R	30*	30*	0.018"	0.018"							

*Compatible Models include 25A, 25B, 30, 30E, 401C & 400 only

CPL No.	Old CPL No.	Engine Model	Engine Brake	Slave Lash	12V Base Kit	24V SL Base Kit	24V DL Base Kit	Engine Control Group	Cab Control Group	Original / Compatible Brakes	Orig. Slave Lash
377		NTE290BCIII	425A	0.018"	3804587	3804588	3804589	N/R	N/R	401B/400H	0.018"
376		NTC400BCI	425A	0.030"	3804587	3804588	3804589	N/R	N/R	30*	0.018"
375		NTC350BCI	425A	0.030"	3804587	3804588	3804589	N/R	N/R	30*	0.018"
374		NTC290BCI	425A	0.030"	3804587	3804588	3804589	N/R	N/R	30*	0.018"
373		NTC250BCI	425A	0.030"	3804587	3804588	3804589	N/R	N/R	30*	0.018"
372		NTC230SC	425A	0.037"	3804587	3804588	3804589	N/R	N/R	25B*	0.018"
369		NTC350BCI	425A	0.030"	3804587	3804588	3804589	N/R	N/R	30*	0.018"
354		NTC250BCI	425A	0.030"	3804587	3804588	3804589	N/R	N/R	30*	0.018"
353		NTC290BCI	425A	0.030"	3804587	3804588	3804589	N/R	N/R	30*	0.018"
349		NTC400BCII	425A	0.030"	3804587	3804588	3804589	N/R	N/R	30E*	0.018"
348		NTC370BCIII	425A	0.018"	3804587	3804588	3804589	N/R	N/R	401B/400H	0.018"
347		NTE350BCIII	425A	0.018"	3804587	3804588	3804589	N/R	N/R	401B/400H	0.018"
345		NTC250BCI	425A	0.030"	3804587	3804588	3804589	N/R	N/R	30*	0.018"
344		NTC290BCI	425A	0.030"	3804587	3804588	3804589	N/R	N/R	30*	0.018"
339		NTC350BCII	425A	0.030"	3804587	3804588	3804589	N/R	N/R	30E*	0.018"
338		NTC290BCII	425A	0.030"	3804587	3804588	3804589	N/R	N/R	30E*	0.018"
332		NTCC290BCI	425A	0.030"	3804587	3804588	3804589	N/R	N/R	30*	0.018"
330		NTC475BCII	425A	0.018"	3804587	3804588	3804589	N/R	N/R	401B/400H	0.018"
329		NTC350BCI	425A	0.030"	3804587	3804588	3804589	N/R	N/R	30*	0.018"
328		NTCC350BCI	425A	0.030"	3804587	3804588	3804589	N/R	N/R	30*	0.018"
327		NTC350BCI	425A	0.030"	3804587	3804588	3804589	N/R	N/R	30*	0.018"
324		NTC400BCI	425A	0.030"	3804587	3804588	3804589	N/R	N/R	30*	0.018"
323		NTC250BCI	425A	0.030"	3804587	3804588	3804589	N/R	N/R	30*	0.018"
322		NTC290BCI	425A	0.030"	3804587	3804588	3804589	N/R	N/R	30*	0.018"
320		NTE290BCI	425A	0.030"	3804587	3804588	3804589	N/R	N/R	30*	0.018"
315		NTC350BCI	425A	0.030"	3804587	3804588	3804589	N/R	N/R	30*	0.018"
314		NTC350YSC	425A	0.037"	3804587	3804588	3804589	N/R	N/R	25B*	0.018"
309		NTC350BCI	425A	0.030"	3804587	3804588	3804589	N/R	N/R	30*	0.018"
308		NTCC350BCI	425A	0.030"	3804587	3804588	3804589	N/R	N/R	30*	0.018"
307		NTC350BCI	425A	0.030"	3804587	3804588	3804589	N/R	N/R	30*	0.018"
306		NTCC290BCI	425A	0.030"	3804587	3804588	3804589	N/R	N/R	30*	0.018"
298		NTC350BCI	425A	0.030"	3804587	3804588	3804589	N/R	N/R	30*	0.018"
294		NTCC350BCI	425A	0.030"	3804587	3804588	3804589	N/R	N/R	30*	0.018"
281		NTCC400BCI	425A	0.030"	3804587	3804588	3804589	N/R	N/R	30*	0.018"
280		NTC335SC	425A	0.037"	3804587	3804588	3804589	N/R	N/R	30*	0.018"
278		NTC350SC	425A	0.037"	3804587	3804588	3804589	N/R	N/R	25B*	0.018"
277		NTCC270BCI	425A	0.030"	3804587	3804588	3804589	N/R	N/R	30*	0.018"
270		NTCC270SC	425A	0.037"	3804587	3804588	3804589	N/R	N/R	25B*	0.018"
267		NTC400BCI	425A	0.030"	3804587	3804588	3804589	N/R	N/R	30*	0.018"
266		NTC350BCI	425A	0.030"	3804587	3804588	3804589	N/R	N/R	30*	0.018"

CPL No.	Old CPL No.	Engine Model	Engine Brake	Slave Lash	12V Base Kit	24V SL Base Kit	24V DL Base Kit	Engine Control Group	Cab Control Group	Original / Compatible Brakes	Orig. Slave Lash
254		NTC350BCI	425A	0.030"	3804587	3804588	3804589	N/R	N/R	30*	0.018"
250		NTCC350BCI	425A	0.030"	3804587	3804588	3804589	N/R	N/R	30*	0.018"
249		NTCC290BCI	425A	0.030"	3804587	3804588	3804589	N/R	N/R	30*	0.018"
248		NTC350SC	425A	0.037"	3804587	3804588	3804589	N/R	N/R	25B*	0.018"
233		NTC290BCI	425A	0.030"	3804587	3804588	3804589	N/R	N/R	30*	0.018"
230		NTCE240BCI	425A	0.030"	3804587	3804588	3804589	N/R	N/R	30*	0.018"
227		NTC290BCI	425A	0.030"	3804587	3804588	3804589	N/R	N/R	30*	0.018"
222		NTC250BCI	425A	0.030"	3804587	3804588	3804589	N/R	N/R	30*	0.018"
221		NTC250SC	425A	0.037"	3804587	3804588	3804589	N/R	N/R	25B*	0.018"
220		NTC230	425A	0.037"	3804587	3804588	3804589	N/R	N/R	25B*	0.018"
217		NTC290	425A	0.037"	3804587	3804588	3804589	N/R	N/R	25B*	0.018"
215		NTCE290	425A	0.037"	3804587	3804588	3804589	N/R	N/R	25B*	0.018"
207		PT270	425A	0.037"	3804587	3804588	3804589	N/R	N/R	25B*	0.018"
205		NTA400	425A	0.037"	3804587	3804588	3804589	N/R	N/R	25B*	0.018"
204		NTCC350	425A	0.037"	3804587	3804588	3804589	N/R	N/R	25B*	0.018"
199		NTC290	425A	0.037"	3804587	3804588	3804589	N/R	N/R	25B*	0.018"
198		NTC335	425A	0.037"	3804587	3804588	3804589	N/R	N/R	25B*	0.018"
197		NTC335	425A	0.037"	3804587	3804588	3804589	N/R	N/R	25B*	0.018"
196		NTC350	425A	0.037"	3804587	3804588	3804589	N/R	N/R	25B*	0.018"
194		NTC290	425A	0.037"	3804587	3804588	3804589	N/R	N/R	25B*	0.018"
190		NTCC335	425A	0.037"	3804587	3804588	3804589	N/R	N/R	25B*	0.018"
189		NTC250	425A	0.037"	3804587	3804588	3804589	N/R	N/R	25B*	0.018"
188		NTC230	425A	0.037"	3804587	3804588	3804589	N/R	N/R	25B*	0.018"
187		NTC290	425A	0.037"	3804587	3804588	3804589	N/R	N/R	25B*	0.018"
182		NTC335	425A	0.037"	3804587	3804588	3804589	N/R	N/R	25B*	0.018"
181		PT270	425A	0.037"	3804587	3804588	3804589	N/R	N/R	25B*	0.018"
178		NTC230	425A	0.037"	3804587	3804588	3804589	N/R	N/R	25B*	0.018"
176		NTC250	425A	0.037"	3804587	3804588	3804589	N/R	N/R	25B*	0.018"
175		PT270	425A	0.037"	3804587	3804588	3804589	N/R	N/R	25B*	0.018"
160		NTC350	425A	0.037"	3804587	3804588	3804589	N/R	N/R	25B*	0.018"
154		NTC350	425A	0.037"	3804587	3804588	3804589	N/R	N/R	25B*	0.018"
147		NTC350	425A	0.037"	3804587	3804588	3804589	N/R	N/R	25B*	0.018"
135		NTA400	425A	0.037"	3804587	3804588	3804589	N/R	N/R	25B*	0.018"
132		NTC335	425A	0.037"	3804587	3804588	3804589	N/R	N/R	25B*	0.018"
117		NHCT270	425A	0.037"	3804587	3804588	3804589	N/R	N/R	25B*	0.018"
115		NTC927	425A	0.037"	3804587	3804588	3804589	N/R	N/R	25B*	0.018"
113		NTC270	425A	0.037"	3804587	3804588	3804589	N/R	N/R	25B*	0.018"
107		NTA400	425A	0.037"	3804587	3804588	3804589	N/R	N/R	25B*	0.018"
101		NTC290	425A	0.037"	3804587	3804588	3804589	N/R	N/R	25B*	0.018"
77		NHTC270	425A	0.037"	3804587	3804588	3804589	N/R	N/R	25B*	0.018"

CPL No.	Old CPL No.	Engine Model	Engine Brake	Slave Lash	12V Base Kit	24V SL Base Kit	24V DL Base Kit	Engine Control Group	Cab Control Group	Original / Compatible Brakes	Orig. Slave Lash
69		NTC335	425A	0.037"	3804587	3804588	3804589	N/R	N/R	25B*	0.018"
26		NH230	425A	0.037"	3804587	3804588	3804589	N/R	N/R	25B*	0.018"
23		NTA420	425A	0.037"	3804587	3804588	3804589	N/R	N/R	25B*	0.018"
22		NTA370	425A	0.037"	3804587	3804588	3804589	N/R	N/R	25B*	0.018"
21		NTC350	425A	0.037"	3804587	3804588	3804589	N/R	N/R	25B*	0.018"
1		NTC335	425A	0.037"	3804587	3804588	3804589	N/R	N/R	25B*	0.018"

ISL Applications

Engine Brake			
Engine Model	Model Year	Base kit	Notes
ISL	1998 to 2002	4089653	<ol style="list-style-type: none"> 1. Not to be used with a Exhaust Brake 2. Kit 4030234 needed for turbos 3597581,3597586, 3597600; Kit 4030233 needed for turbos 3597576, 3597584; No Kit Required for Turbo 3597099 3. For 24 V application, order two(2) of p/n 4089625
ISL03	2003 to 2006	4089626	<ol style="list-style-type: none"> 1. Not to be used with Exhaust Brake 2. Replace Valve Cover 3967770 with 3967777, 3967763 with 3967773, or 3967766 with 3967776
ISL07	2007	4089626	<ol style="list-style-type: none"> 1. Not to be used with Exhaust Brake 2. Replace Valve Cover 3967770 with 3967777, 3967763 with 3967773, or 3967766 with 3967776
Engine Brake			
Engine Model	Model Year	Base kit	Notes
ISC07	2007	4089626	<ol style="list-style-type: none"> 1. Only for use with ISC07 engine, cannot be used with ISC models prior to 2007 2. Not to be used with Exhaust Brake 3597584; No Kit Required for Turbo 3597099 3. Replace Valve Cover 3967770 with 3967777, 3967763 with 3967773, or 3967766 with 3967776

Medium Duty Applications

E Brake for Manual Transmission Dodge Ram Trucks

Engine Model	Model Year	Base kit	Mopar P/N	Header Group
B5.9 Mechanical	1989 - 1998	3804848	N/A	3804854 (for '89 - '93 vehicles ONLY; not required for 94 and later vehicles)
ISB 5.9 Electronic	1998.5 - 2002	3800792	82205577	
ISB 5.9 Electronic	2003 - 2004	4089427	N/A	
ISB 5.9 Electronic	2004.5 - Current	4089598	82208835AB	

E Brake for Cummins Engine Applications (not including Dodge Ram Truck)

- For all Cummins Engine applications, first determine the base kit by engine/turbo type, then order the appropriate pneumatic group. If the vehicle has an on-board air supply, order the standard pneumatic group. If the vehicle does not have an on-board air supply (i.e. has hydraulic brakes), then order the pneumatic group with auxiliary air supply.
- For Turbo-mount applications, you must first determine the turbo outlet type. Locate the part number cast into the turbo outlet and find the number in the chart below under "Turbo Outlet." Then choose the corresponding base kit and pneumatic group.

Engine Model	Configuration	Turbo outlet	Base kit	Pneumatic Group	Pneumatic Group with Air Supply
B5.9 Mechanical	In Pipe	N/A	3802671	3803910	3802673
C8.3 Mechanical	In Pipe	N/A	3802672	3803910	3802673
ISB 5.9 Electronic	Half Marmon	3527759	3800442	3806238	3806237
ISB 5.9 Electronic	Full Marmon	3538180	3800443	3806238	3806237
ISB 5.9 Electronic	In Pipe	N/A	3800441	3806238	3806237
ISC 8.3 Electronic	Half Marmon	3537979	3800414	3806238	3806237
ISC 8.3 Electronic	Full Marmon	3539060	3800415	3806238	3806237
ISC 8.3 Electronic	In Pipe	N/A	3800372	3806238	3806237
ISB02 5.9 Electronic	Full Marmon		4089591	3806238	3806237
ISB02 5.9 Electronic	In-Pipe		4089593	3806238	3806237
ISC03 8.3 Electronic	Full Marmon		4089624	3806238	3806237
ISC03 8.3 Electronic	In-Pipe		4089623	3806238	3806237
ISL 9.0L Electronic	Half Marmon		3800416	3806238	3806237
ISL 9.0L Electronic	Full Marmon		3800415	3806238	3806237
ISL 9.0L Electronic	In-Pipe		3800372	3806238	3806237
ISL03 9L Electronic	Full Marmon		4089624	3806238	3806237
ISL03 9L Electronic	In-Pipe		4089623	3806238	3806237

Note: 24V pneumatic group with air supply group not available

Out of Production Models

Models are listed numerically by model number. Some models may be upgraded to later configurations. If applicable, upgrade information is listed for each model. When updating a brake housing to a new model configuration, be sure to stamp the nameplate with the new model number.



DO NOT ATTEMPT TO UPGRADE ENGINE BRAKES EXCEPT AS NOTED BELOW. SEVERE ENGINE OR ENGINE BRAKE DAMAGE MAY RESULT.

Model 20

This model was designed for 5 1/8" bore NH-200 Engines. These housings are not upgradeable, and should be used only where they were originally specified.



DO NOT USE THIS ENGINE BRAKE ON ENGINES EQUIPPED WITH DUAL ENTRY TURBOS.

Models 25, 25A, 25B, and 25C:

These models were designed for use on 5 1/2" bore Small Cam NH & NT engines. These housings are not upgradeable, and should be used only where they were originally specified.



DO NOT USE THIS ENGINE BRAKE ON ENGINES EQUIPPED WITH DUAL ENTRY TURBOS.

Model 30

This model was designed for Big Cam I engines with FFC. These housings are not upgradeable, and should be used only where they were originally specified. Cummins has released conversion kits for these engines to give them Big Cam II features, including a DFC oil system. If one of these conversions has been done, the engine brake must be modified per Jacobs Service Letter 202.



DO NOT USE THIS ENGINE BRAKE ON ENGINES EQUIPPED WITH DUAL ENTRY TURBOS.

Model 30E

This model was designed for Big Cam II engines with DFC. Early Model 30E's use a 3/8" slave piston adjusting screw. These housings are not upgradeable, and should be used only where they were originally specified. Later Model 30E's use a 1/2" adjusting screw. These housings can be upgraded to Model 400 or 400H. When upgraded, they can be used wherever a Model 400 or 400H is specified.

To upgrade to Model 400, change the following components:

- Replace slave piston adjusting screw with P/N 3871409 Autolash.

To upgrade to Model 400H, change the following components:

- Replace slave piston adjusting screw with P/N 3871407 Autolash (available as a package of 6 only).

Model 30SN

This model was designed for “Pancake” style Big Cam I engines. These engines are mounted 15 degrees from horizontal, typically mounted under the body in bus applications. The Model 30SN housings incorporate spray nozzles in the underside of the housing to facilitate lubrication of the engine overhead. These nozzles do not affect the ability to use this model on other engines. Upgradeability and usage recommendations are therefore the same as Model 30.



DO NOT USE HOUSINGS WITHOUT SPRAY NOZZLES ON HORIZONTAL ENGINES.

Model 44B

This model was designed for use with early NH/NT engines. Without upgrading, they should only be used where originally specified. These housings can be upgraded to Model 400 or 400H. When upgraded, they can be used wherever a Model 400 or 400H is specified.

To upgrade to Model 400, change the following components:

- Replace slave piston adjusting screw with P/N 3871409 Autolash.
- Replace pressure relief Master pistons with P/N 3871330 master pistons.

To upgrade to Model 400H, change the following components:

- Replace slave piston adjusting screw with P/N 3871407 Autolash (available as a package of 6 only).
- Replace pressure relief Master pistons with P/N 3871330 master pistons.

Model 400

This model is designed for use on NH/NT Big Cam II and III engines with single entry turbos. Without upgrading, they should only be used where originally specified. These housings can be upgraded to Model 400H. When upgraded, they can be used wherever a Model 400H is specified.

To upgrade Model 400 to Model 400H, change the following components:

- Replace slave piston adjusting screw with P/N 3871407 Autolash (available as a package of 6 only).

Model 400H

This model is designed for use on Big Cam II and III NT engines with dual entry turbos. These housings can be used wherever a Model 400H is specified. These can be converted to Model 400.

To convert Model 400H to Model 400, change the following components:

- Replace slave piston adjusting screw with P/N 3871409 Autolash.

Model 401A

This is a single valve opening design, intended for use on NTC475 twin turbo engines. No conversions or upgrades are possible. These housings should be used only where they were originally specified.

Model 401B

This is a single valve opening design, intended for use on NH/NT Big Cam engines with dual entry turbos, including the NTC 475 MVT engine. Use of this brake on engines with single entry turbos will yield poor engine brake performance. Conversion for use with single entry turbos is not possible. Use this brake on engines where originally specified.

Model 401C

This is a single valve opening design, intended for use on NH/NT Big Cam engines with single entry turbos, and new Big Cam IV engines. Use of this brake on engines with dual entry turbos will cause premature wear and other engine damage. Conversion for use with dual entry turbos is not possible. Use this brake on engines where originally specified.

Models 404 and 404B

These models were designed for use on specific L10 engines. They can be used wherever originally specified, or they can be upgraded to Model 404BG, and used wherever a Model 404BG is specified.

To upgrade to Model 404BG, use upgrade group P/N 3871513.

Model 404C

This model was designed for use on specific L10 engines. They can be used wherever Model 404D is specified. No upgrade is required.

Models 420 and 425

These models were designed for use on pre '88/'89 Small Cam and Big Cam NH/NT engines. Model 425 can be used wherever a Model 425A is specified. No upgrade is required. Model 420 Can be upgraded to Model 425A, and used wherever Model 425A is specified.

To upgrade Model 420 to Model 425A, change the following components:

- Replace existing Autolash with P/N 3871676 Autolash.

Model 440

This model was designed for use on specific N14 engines. It can be used wherever originally specified, or upgraded to Model 440A . When upgraded, it can be used wherever a Model 440A is specified.

To upgrade Model 440 to Model 440A, change the following components:

- Replace slave piston adjusting screw with P/N 3871674 Autolash.

Model 445

This model was designed for specific N14 engines. It is not upgradeable, and should be used only where originally specified.

Models 59, 59A and 59B

These models were designed for small six and eight cylinder V-engines. Model 59 can be used on small cam engines with max. oil pressure below 87 PSI. Model 59A can be used on small cam engines with up to 110 PSI oil pressure. Model 59B can be used on either big or small cam engines, however, more than 6 housings should not be used per engine (i.e. brake housings should be installed on only 6 cylinders of an 8 cylinder engine). The lash setting for these models is 0.028" for big cam engines, and 0.038" for small cam engines. Some conversions are possible. Refer to the parts and installation manuals for more information.

Models 903A and 903B

These models were designed for VT903 engines. Model 903A was designed for engines using a 1:1 rocker ratio, which were built after Feb. 1, 1976. Model 903B was designed for engines using 1.2:1 rocker ratio, which were built before Feb. 1, 1976. Engines built prior to S/N 10951093 require modifications prior to the installation of the brakes. The lash setting for these models is 0.023". Refer to the parts and installation manuals for more information.

Models K200, K1150, and K1200

These models are designed for use with K series engines. Model K200 can be used on KT-450 and KTA-600 engines only. Models K1150 and K1200 can be used on KT-450, KTC-450, KTA-600, and KTA-525 PTD engines. Refer to the parts and installation manuals for more information and adjustment procedures. These housings cannot be



Cummins Engine Company, Inc.
Box 3005
Columbus, IN 47202-3005
U.S.A.

Bulletin 3401804
Printed in U.S.A. 03/07
©2006 Jacobs Vehicle Systems, Inc.

020994 Rev. F