

PEAK™ substation transformers



General

Eaton's Cooper Power™ series PEAK™ substation transformers are a class of transformer technologies that are designed to improve performance in terms of kVA rating, compact dimensions, lighter weight, safety, and sustainability.

Flexibility in design, combined with the highest quality manufacturing processes, equipment, and testing procedures, enable Eaton to provide a product optimized to the customer's requirements. All units meet applicable American National Standards Institute (ANSI®), Institute of Electrical and Electronics Engineers, Inc. (IEEE®) and National Electrical Manufacturers Association (NEMA®) standards, as well as National Electric Code (NEC®), Department of Energy (DOE) and Canadian Standards Association (CSA) specifications.

PEAK substation transformers are available with cover-mounted bushings or enclosed sidewall-mounted bushings for connections to primary and/or secondary switchgear. Conventional transformers operate at 65 °C for the Average Winding Rise (AWR) at full load. PEAK transformers are currently available with ratings up to 75 °C AWR.

PEAK transformers are IEEE Std C57.154™-2012 standard compliant, available with all current conventional transformer options. They are offered in either 65/75 °C or 55/75 °C slash ratings or 75 °C rise rated configurations. A 65/75 °C rated PEAK transformer is comparable in size to a conventional transformer but has nameplated overload capability. A 75 °C rise rated PEAK transformer is smaller in size but delivers the same kVA as its conventional counterpart.

All PEAK transformers use Envirottemp™ FR3™ dielectric fluid. Envirottemp™ FR3™ has a higher flash point than conventional transformer fluids which increases PEAK transformers fire protection. Envirottemp™ FR3™ fluid increases the life span of the transformer insulation to a point where the overall life expectancy for PEAK transformers is significantly increased.

In addition, PEAK transformers meet Occupational Safety and Health Administration (OSHA) and Section 450.23, 2014 NEC® requirements.

Electrical codes recognize the advantages of using Envirottemp™ FR3™ fluid both indoors and outdoors for fire-sensitive applications.

EATON

Powering Business Worldwide



Figure 1. PEAK substation transformer with standard features and optional accessories.

Product Scope

Type	Three-Phase or Single-Phase, 50 or 60 Hz (65/75 °C, 55/75 °C, or 75 °C)
Fluid Type	Envirotemp™ FR3™ fluid
Size	Three-Phase: 300 – 12,000 kVA Single-Phase: 250 – 5000 kVA
Primary Voltage	2400 – 46,000 V
Secondary Voltage	208-15,000 V (25 kV available upon special request)
Specialty Designs	Hardened Data Centers Grounding Transformers K-Factor (up to K-20) Hazardous Location (Class I, Division 2, Groups B, C, and/or D) Solar/Wind Designs Variable Speed Drives or Rectifier Duty Mining/Skid-Mounted Applications

Table 1. Three-Phase, Single Temperature kVA Ratings

Three-Phase kVA Self-Cooled and Forced-Air Cooled with 75 °C Temperature Rise

75 °C Rise KNAN	75 °C Rise KNAN/KNAF
500	N/A
750	863
1000	1150
1500	1725
2000	2300
2500	3125
3750	4688
5000	6250
7500	9375
10000	12500
12000	16000

+15% (between 1000 and 2500)
+25% (between 2500 and 7500)
+33% (between 7500 and 12000)

Table 4. Three-Phase, Dual or Triple Temperature kVA Ratings¹

Three-Phase kVA Self-Cooled and Forced-Air Cooled with PEAK Triple Rated 55 °C/65 °C/75 °C Temperature Rise

55 °C Rise KNAN	65 °C Rise KNAN	75 °C Rise KNAN	55 °C Rise KNAN/KNAF	65 °C Rise KNAN/KNAF	75 °C Rise KNAN/KNAF
500	560	610	N/A	N/A	N/A
750	840	916	863	966	1053
1000	1120	1221	1150	1288	1404
1500	1680	1831	1725	1932	2106
2000	2240	2442	2300	2576	2808
2500	2800	3052	3125	3500	3815
3750	4200	4578	4688	5250	5723
5000	5600	6104	6250	7000	7630
7500	8400	9156	9375	10500	11445
10000	11200	12208	12500	14000	15260
12000	13440	14650	16000	17920	19533

+12% (between 2500 and 3750)
+9% (between 3750 and 5000)

¹ If 65 °C Rise is the base rating, the 75 °C slash rating will increase the kVA capacity by 12%.

Table 2. Impedance Voltage

kVA Rating (1PH and 3PH)	Impedance Voltage ¹		
	HV BIL (kV)	LV 600 V and below	LV above 600 V
112.5-749	≤200	1.70-5.75	1.70-5.75
750-4999	≤110	5.75	5.75
750-4999	150	6.75	6.5
750-4999	200	7.25	7
750-4999	250	7.75	7.5
5000-10000	150	-	6.5
5000-10000	200	-	7
5000-10000	250	-	7.5

¹ The standard tolerance is ±7.5%.

Note: Impedances listed above are per IEEE Std C57.12.36™-2007 standard. Impedances per IEEE Std C57.12.10™-2010 standard are also available.

Table 3. Audible Sound Levels

Self-Cooled, Two Winding kVA Rating	NEMA® Average	
	dB, KNAN	dB, KNAF
500	56	N/A
501-700	57	67
701-1000	58	67
1001-1500	60	67
1501-2000	61	67
2001-2500	62	67
2501-3000	63	67
3001-4000	64	67
4001-5000	65	67
5001-6000	66	68
6001-7500	67	69
7501-10000	68	70
10001-12500	69	71

Table 5. Insulation Test Levels

kV Class	Induced Test 180 or 400 Hz 7200 Cycle	kV BIL		Applied Test 60 Hz (kV)
		Distribution	Power	
1.2		30	45	10
2.5		45	60	15
5		60	75	19
8.7		75	95	26
15	TWICE RATED VOLTAGE	95	110	34
25 (Grd Y Only)		125	150	40
25		150	150	50
34.5 (Grd Y Only)		150	200	50
34.5		200	200	70
46		250	250	95

Table 6. Temperature Rise Ratings 0-3300 feet (0-1000 meters)

	Standard
Unit Rating	75 °C, 65/75 °C, 55/75 °C
Maximum Ambient Temperature Rise	40 °C, 65/75 °C, 55/75 °C
Ambient Temperature 24 Hour Av.	30 °C, 65/75 °C, 55/75 °C
Temperature Rise Winding ¹	75 °C, 65/75 °C, 55/75 °C

¹ Average Rise by resistance. Refer to IEEE Std C57.12.00™-2010 standard.

Note: Derate kVA by 0.4% for each 100 M (330 ft.) that the altitude is above 1000 M (3300 ft.).

Table 7. Fluid-Filled—Aluminum Windings 75 °C Rise¹

kVA	Drawing Dimensions (in.)									Gallons	Weight
	A	B	C	D	E	F	G	H	J		
500	66	55	26	47	45	45	31	62	35	310	5600
750	66	55	30	56	55	55	31	62	35	330	6400
1000	66	59	30	60	55	55	33	66	35	360	7500
1500	75	63	30	60	55	55	35	70	35	400	9600
2000	75	67	36	64	55	55	37	74	39	460	12000
2500	75	71	36	64	55	55	39	78	39	500	13500
3750	85	75	64	95	65	65	41	82	41	730	18500
5000	85	83	66	107	65	65	45	90	45	820	22600
7500	99	87	67	120	75	75	47	94	47	1100	31000
10000	99	95	70	142	75	75	51	102	53	1360	38000
12000	99	103	75	152	75	75	55	110	57	1550	45000

¹ Weights, gallons of fluid, and dimensions are for reference only and not for construction. Please contact your Eaton representative for exact dimensions.

Table 8. Fluid-Filled—Copper Windings 75 °C Rise¹

kVA	Drawing Dimensions (in.)									Gallons	Weight
	A	B	C	D	E	F	G	H	J		
500	66	47	26	47	45	45	27	54	35	280	5400
750	66	55	30	56	55	55	31	62	35	360	6600
1000	66	55	30	60	55	55	31	62	35	360	7700
1500	75	59	30	60	55	55	33	66	35	410	10000
2000	75	63	31	62	55	55	35	70	37	460	12200
2500	75	71	32	64	55	55	37	74	39	500	14000
3750	75	71	64	95	55	55	39	78	41	590	17200
5000	85	79	66	105	65	65	43	86	45	880	23700
7500	85	87	67	120	75	75	47	94	47	990	30800
10000	99	91	69	140	75	75	49	98	51	1310	37000
12000	99	95	74	150	75	75	51	102	55	1430	43000

¹ Weights, gallons of fluid, and dimensions are for reference only and not for construction. Please contact your Eaton representative for exact dimensions.

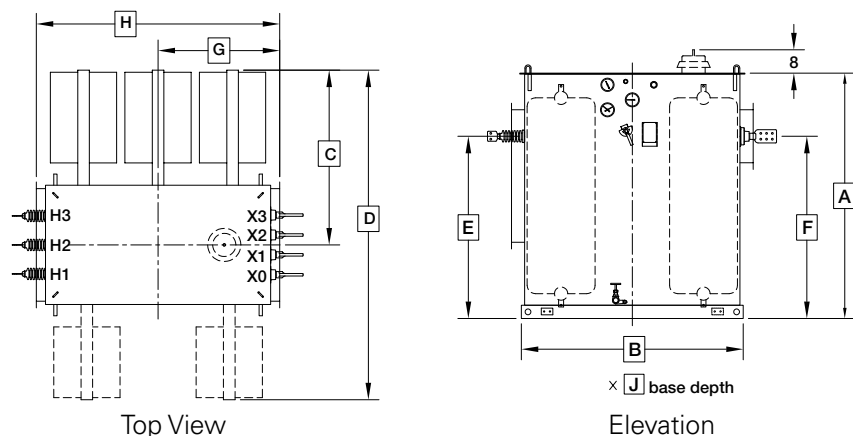

Figure 2. High-Voltage left (Segment 2) shown. High-Voltage right (Segment 4) also available.

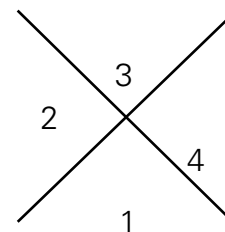

Figure 3. ANSI® segment designation.

Table 9. Fluid-Filled—Aluminum Windings 65/75 degree C Rise¹

kVA	Drawing Dimensions (in.)									Gallons	Weight
	A	B	C	D	E	F	G	H	J		
500	66	55	26	45	45	45	31	62	35	320	5700
750	66	59	30	56	55	55	33	66	35	380	6800
1000	66	63	30	60	55	55	35	70	35	420	8100
1500	75	67	31	62	55	55	37	74	37	460	10300
2000	75	67	55	84	55	55	37	74	37	490	12100
2500	85	69	62	91	55	55	39	78	39	540	14500
3750	85	75	64	104	65	65	41	82	41	770	19600
5000	85	83	66	120	65	65	45	90	45	920	24000
7500	99	91	68	137	75	75	49	98	49	1260	33300
10000	99	99	70	141	75	75	53	106	53	1550	40000
12000	99	103	75	152	75	75	55	110	57	1670	47000

¹ Weights, gallons of fluid, and dimensions are for reference only and not for construction. Please contact your Eaton representative for exact dimensions.

Table 10. Fluid-Filled—Copper Windings 65/75 degree C Rise¹

kVA	Drawing Dimensions (in.)									Gallons	Weight
	A	B	C	D	E	F	G	H	J		
500	66	47	26	45	45	45	27	54	35	290	5800
750	66	55	30	56	55	55	31	62	35	360	7200
1000	66	59	30	60	55	55	33	66	35	390	8400
1500	75	63	30	60	55	55	35	70	35	430	10400
2000	75	63	62	91	55	55	35	70	37	460	12500
2500	75	67	63	93	55	55	37	74	39	540	14100
3750	85	75	65	110	65	65	41	82	43	740	20000
5000	85	83	66	120	65	65	45	90	45	960	25000
7500	99	91	68	137	75	75	49	98	49	1250	34000
10000	99	95	70	141	75	75	51	102	53	1520	41000
12000	99	103	75	152	75	75	55	110	57	1740	46000

¹ Weights, gallons of fluid, and dimensions are for reference only and not for construction. Please contact your Eaton representative for exact dimensions.

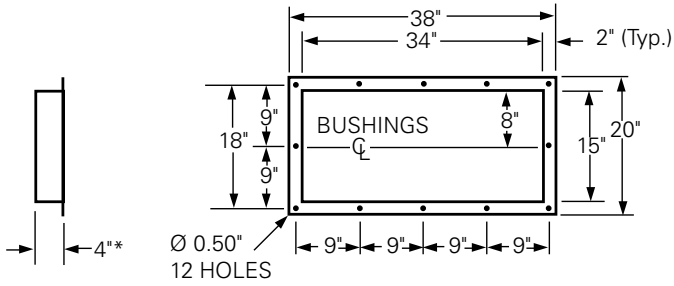

Figure 4. Throat.

* Increase to 5" for containment pans.

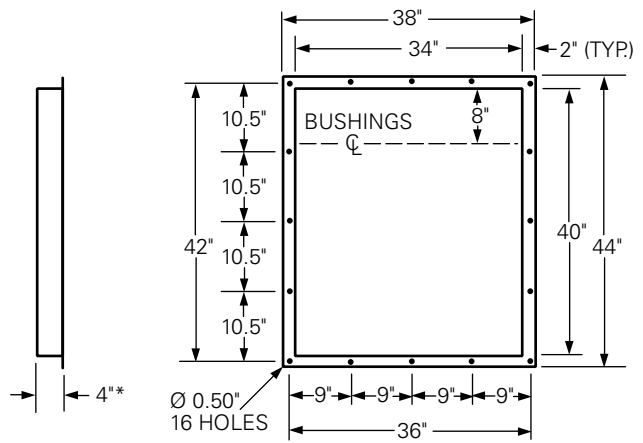

Figure 7. Flange.

* Increase to 5" for containment pans.

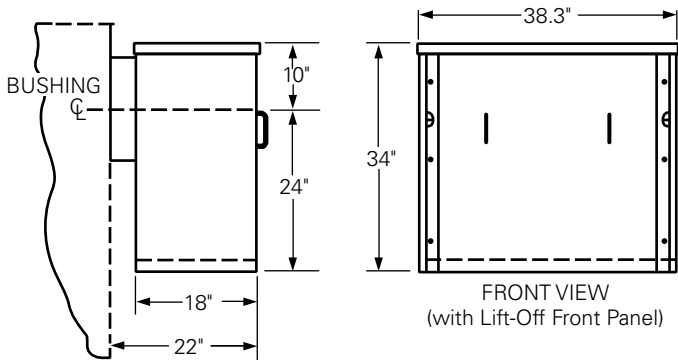

Figure 5. Air terminal chamber-bottom entry.

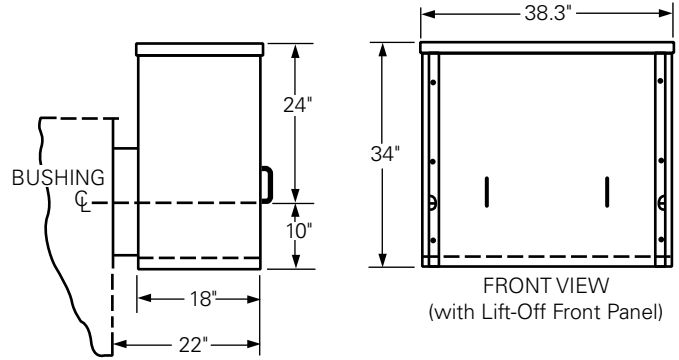

Figure 8. Air terminal chamber-top entry.

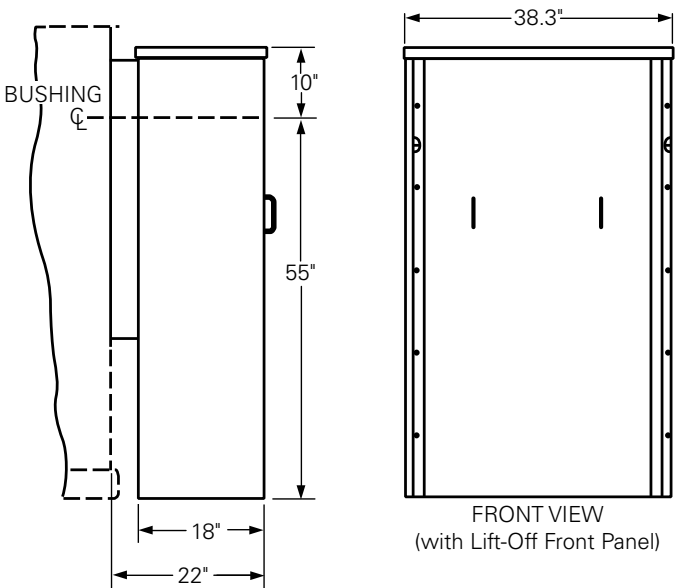

Figure 6. Full length cabinet-bottom entry.

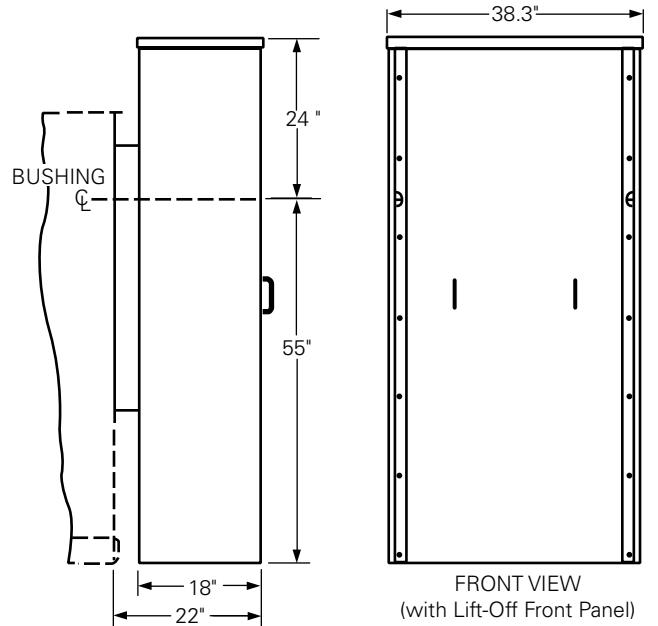

Figure 9. Full length cabinet-top entry.

Standard features

Fluid

- Envirotemp™ FR3™ fluid

Mechanical features

- De-energized tap changer, externally operable

High- and low-voltage bushings

- Cover or sidewall-mounted high-voltage porcelain bushings
- Cover or sidewall-mounted low-voltage molded epoxy bushings with NEMA® spades
 - Deadfront bushings also available

Tank

- Tank bases designed for skidding or rolling in any direction
- Extra-heavy, welded-in-place lifting lugs (4) and jacking provisions
- Stainless steel grounding pads (4)
- Cooling radiators or corrugate welded directly to the tank

Gauges and devices

- Dial-type thermometer
- Dial-type liquid level gauge
- Pressure vacuum gauge
- Cover-mounted automatic pressure relief device
- Pressure test connection

Valves/plugs

- 1" upper fill plug with filter press connection
- 1" upper filter valve (over 2500 kVA)
- 1" drain valve with sampler combination (2500 kVA and below)
- 2" drain valve with sampler (over 2500 kVA)

Coatings (paint)

- ANSI® #61 Light Gray
- ANSI® #70 Sky Gray
- Special paint available per request

Nameplate

- Laser-scribed anodized aluminum nameplate

Optional features

Bushing enclosure options

- Throat
- Flange
- Top- or bottom-entry air terminal chamber
- Top- or bottom-entry full length cabinet

Gauges and devices

- With Alarm Contacts
 - Dial-type thermometer (Standard with Fan Package)
 - Liquid level gauge
 - Pressure/vacuum gauge
 - Cover-mounted pressure relief device
 - Winding temperature indicator
- Rapid pressure rise relay with optional seal-in panel
- Nitrogen gas preservation system
- Infrared (IR) Windows



Figure 10. Automation solutions for remote monitoring.



Figure 11. 12-pulse application with bushing supports.

Valves/plugs

- Pressure vacuum bleeder valve
- Detachable, bolt-on radiators with valves

Control boxes

- Control box (NEMA® 4, NEMA® 4X, NEMA® 7)

Forced-air fan control package

- Forced-air fan control package includes fans, NEMA® control box, fan controls, dial-type thermometer with alarm contacts.

Overcurrent protection

- Bay-O-Net Fuse with Isolation Link
- Bay-O-Net Fuse with Partial Range Current Limiting Fuse
- Primary air disconnect switch with fuses

Overvoltage protection

- Distribution-, Intermediate-, or Station-class surge arresters
- Elbow arresters (for dead-front connections)

Tank

- 304L stainless steel

Construction

Core

The three-legged, step-lap mitered core construction is manufactured using a high-quality cutting machine. For maximum efficiency, cores are precisely stacked, virtually eliminating gaps in the corner joints.

Five-legged wound core or shell-type triplex designs are used for wye-wye connected transformers, and other special transformer designs.

Cores are manufactured with precision cut, burr-free, grain-oriented silicon steel. Many grades of core steel are available for optimizing core loss efficiency.

Coils

Substation transformers feature a rectangular coil configuration with wire-wound, high-voltage primaries and sheet-wound secondaries. The design minimizes axial stress developed by short circuits and provides for magnetic balancing of tap connections.

Coils are wound using the highest quality winding machines providing exacting tension control and conductor placement for superior short-circuit strength and maximum efficiency.

Extra mechanical strength is provided by diamond pattern, epoxy coated paper insulation, used throughout the coil, with additional epoxy at heavy stress points. The diamond pattern distribution of the epoxy and carefully arranged ducts, provide a network of passages through which cooling fluid can freely circulate.

Coil assemblies are heat-cured under calculated hydraulic pressure to ensure performance against short-circuit forces.

Core and coil assemblies

Substation transformer core and coil assemblies are braced with heavy steel ends to prevent the rectangular coil from distorting under fault conditions. Plates are clamped in place using presses, and welded or bolted to form a solid core and coil assembly. Core and coil assemblies exceed ANSI® and IEEE® requirements for short-circuit performance. Due to the rigidity of the design, impedance shift after short-circuit is comparable to that of circular wound assemblies.

Tanks

Transformer tanks are designed for high strength and ease of handling, installation, and maintenance. Tanks are welded using precision-cut, hot rolled, pickled and oiled steel. They are sealed to protect the insulating fluid and other internal components.

Transformer tanks are design tested to withstand 7 psig without permanent distortion and 15 psig without rupture.

Tank finish

An advanced multi-stage finishing process exceeds IEEE Std C57.12.28™-2014 standard. The eight-stage pre-treatment process assures coating adhesion and retards corrosion. It converts tank surfaces to a nonmetallic, water insoluble iron phosphate coating.

The paint method consists of three distinct layers of paint. The first is an epoxy primer (E-coat) layer which provides a barrier against moisture, salt and corrosives. The two-component urethane final coat seals and adds ultraviolet protection.

Vacuum processing

Transformers are dried and filled with filtered insulating fluid under vacuum, while secondary windings are energized. Coils are heated to drive out moisture, ensuring maximum penetration of fluid into the coil insulation system.

Cooling system

Less flammable fluid filled-air cooling (KNAN) cooling is provided with transformers rated 500 kVA. A choice of KNAN/ Future KNAF (Future Forced-Air) or KNAN/KNAF (Forced-Air) cooling is provided with units rated 750 kVA and above.

Insulating fluid

Eaton's Cooper Power series transformers are available with Envirotemp™ FR3™ fluid. The highly refined fluid is tested and degassed to assure a chemically inert product with minimal acid ions. Special additives minimize oxygen absorption and inhibit oxidation. To ensure high dielectric strength, the fluid is re-tested for dryness and dielectric strength, refiltered, heated, dried, and stored under vacuum before being added to the completed transformer.

Eaton's Cooper Power series transformers filled with Envirotemp™ FR3™ fluid enjoy unique fire safety, environmental, electrical, and chemical advantages, including insulation life extending properties.

A bio-based, sustainable, natural ester dielectric coolant, Envirotemp™ FR3™ fluid quickly and thoroughly biodegrades in the environment and is non-toxic per acute aquatic and oral toxicity tests.

Building for Environmental and Economic Sustainability (BEES) total life cycle assessment software, utilized by the US Dept. of Commerce, reports its overall environmental performance impact score at 1/4th that reported for mineral oil. Envirotemp™ FR3™ fluid has also earned the EPA Environmental Technology Verification of transformer materials.

Underwriters Laboratories® (UL®) Listed & Labeled/ Classified

Eaton's Cooper Power series Envirotran™ transformer can be specified as UL® Listed & Labeled and/or UL® Classified.

Underwriters Laboratories (UL®) listing is a verification of the design and construction of the transformer to the ANSI® and IEEE® standards. UL® listing generally is the most efficient, cost-effective solution for complying with relevant state and local electrical codes.

UL® Combination Classification/Listing is another way in which to comply with Section 450.23, 2014 NEC® requirements. This combines the UL® listed transformer with a UL® Classified Less-Flammable Liquid and complies with the use restrictions found within the liquid Classification.

Envirotran™ FM Approved® transformer

Eaton's Cooper Power series Envirotran™ transformer is FM Approved® and suitable for indoor locations. FM Global® approval of the Envirotran transformer line makes it easy to comply and verify compliance with Section 450.23, 2014 NEC®, Less-Flammable Liquid-Filled Transformer Requirements for both indoor and outdoor locations.

FM Approved® Envirotran transformers offer the user the benefit of a transformer that can be easily specified to comply with NEC® and makes FM Global® Property Loss Prevention Data Sheet compliance simpler, while also providing maximum safety and flexibility for both indoor and outdoor installations.

Since the "FM Approved®" logo is readily visible on the transformer and its nameplate, NEC® compliance is now easily verifiable by the inspector.

Substation Envirotran FM Approved® transformers, part of Eaton's Cooper Power series transformers, are manufactured under strict compliance with FM Standard 3990 and are filled with FM Approved® Envirotemp™ FR3™ fluid, a fire-resistant dielectric coolant.



Specialty designs

Hardened data center

Envirotran Hardened Data Center (HDC) transformers are designed for critical Data Center power delivery where the absolute highest reliability is required and where mere "Industry Standard" isn't good enough! HDC liquid filled transformers are engineered with higher electrical withstand, increased levels of insulation, and greater electrical clearance. All HDC transformers are subjected to a more stringent series of factory tests which include a higher BIL withstand than standards dictate for its kV rating and special assurance tests for sealing integrity. Furthermore, Envirotran HDC transformers are provided with bio-based Envirotemp™ FR3™ fluid that carries FM Approved® rated fire resistance, provides extended insulation life, and ultimate biodegradability. All of these characteristics far surpass those of more traditional dry type transformers. Rest assured, Envirotran HDC will deliver the highest standard of reliability, quality, and performance available in the industry today. See *Bulletin B210-10035, Data Center Solutions* for details.

Grounding transformers

Eaton offers customized grounding for its Cooper Power series transformers for applications where a ground path needs to be introduced to a system.

Hazardous locations (Class I Division 2)

Hazardous locations can be defined as areas where combustible materials are present. Eaton is offering UL® Listed explosion proof designs for its Cooper Power series transformers that prevent gasses from coming in contact with switching arcs. These explosion proof control boxes are made of cast aluminum and are designed to contain an arc.

K-Factor

Eaton designs its Cooper Power series transformers with appropriate K-factor correction to mitigate the effects of non-linear harmonic loading conditions.

Solar/Wind Designs

Eaton is offering custom designs for renewable energy power generation. Eaton manufactures its Cooper Power series Generator Step-Up (GSU) transformers for use at the base of each wind turbine. Additionally, grounding transformers are available for wind power generation. For the solar photovoltaic industry, Eaton is offering its Cooper Power series inverter step-up transformers, as well as dual secondary designs to isolate a two-inverter input.

Special protection features

Primary air disconnect switch

- Provides economical, visible disconnect primary load break switching
- Fully coordinated and packaged with the transformer
- Meets IEEE Std C37.20.3™-2013 standard, NEMA® SG-5 and related standards
- Standard features
 - Switch
 - Three-pole, two-position, gang-operated air interrupter, unfused
- Standard ratings
 - 600 A continuous and load break; 40 kA fault close and momentary
 - 5 kV (60 kV BIL) or 15 kV (95 kV BIL)
- Enclosure
 - Standardized modular self supporting, bolted design
 - Mechanical safety interlock prevents access when switch is closed or closing of switch when door is open
- Optional features
 - 1200 A continuous and load break current rating; 61 kA fault close and momentary. Requires 1200 A copper bus option.
 - Key interlocks (single cylinder) for interlocking primary switch with secondary main circuit protective device
 - Auxiliary switch for remote indication of primary switch position
 - Where high interrupting ratings and short-circuit protection are desired: current-limiting non-expulsion power fuses
 - Where lower interrupting ratings are adequate:
 - Non-disconnect power fuses
 - Disconnect power fuses

Testing

Eaton performs routine testing on each Cooper Power series transformer manufactured including the following tests:

- **Ratio, Polarity, and Phase Relation:** Ensures correct winding ratios and tap voltages; checks insulation of HV and LV circuits. Checks entire insulation system to verify all live-to-ground clearances.
- **Winding Resistance:** This test verifies the integrity of internal high-voltage and low-voltage connections; provides data for loss upgrade calculations.
- **Insulation Power Factor:** This test verifies that vacuum processing has thoroughly dried the insulation system to required limits.
- **Routine Impulse Tests:** The most severe test, simulating a lightning surge. Applies one reduced wave and one full wave to verify the BIL rating.
- **Applied Potential:** Applied to both high-voltage and low-voltage windings, this test stresses the entire insulation system to verify all live-to-ground clearances.
- **Induced Potential:** This test verifies the turn-to-turn and layer-to-layer insulation at twice the rated voltage.
- **Loss Test:** These design verification tests are conducted to ensure that guaranteed loss values are met and that test values are within design tolerances. Tests include no-load loss and excitation current along with impedance voltage and load loss.
- **Leak Test:** Pressurizing the tank to 5 psig assures a complete seal, with no weld or gasket leaks, to eliminate the possibility of moisture infiltration or oil oxidation.

Design performance tests

Design performance tests include the following:

- **Temperature Rise:** Our automated heat run facility ensures that any design changes meet ANSI® and IEEE® temperature rise criteria.
- **Audible Sound Level:** Ensures compliance with NEMA® requirements.
- **Lightning Impulse:** To assure superior dielectric performance, this test consists of one reduced wave, two chopped waves and one full wave in sequence across the medium voltage windings, precisely simulating the harshest conditions.

Optional tests

The following tests are available for purchase:

- Zero sequence impedance
- RIV (Corona)
- Extended leak test
- Dissolved gas analysis (DGA)
- PCB fluid testing
- Fluid dielectric strength
- Detection of sulfur dioxide

Thomas A Edison Technical Center

We are constantly striving to introduce new innovations to the transformer industry, bringing you the highest quality transformer for the lowest cost. Eaton's Cooper Power series Transformer Products are ISO 9001 compliant, emphasizing process improvement in all phases of design, manufacture, and testing. We have invested millions of dollars in the Thomas A. Edison Technical Center, our premier research facility in Franksville, Wisconsin affirming our dedication to introducing new innovations and technologies to the transformer industry. This research facility is fully available for use by our customers to utilize our advanced electrical and chemical testing labs.

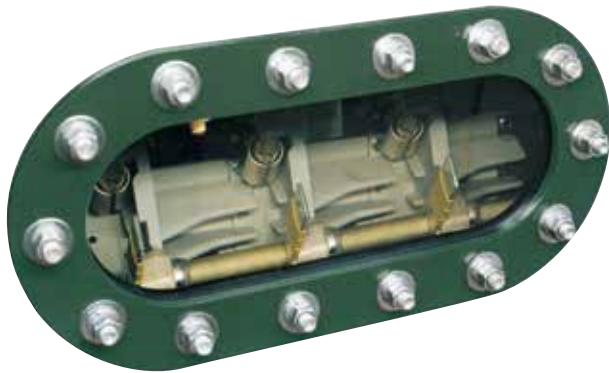

Figure 12. Substation transformer with visible break technology.



Figure 14. Triplex Indoor Power Center comprised of energy efficient and low noise single-phase substation transformers in a ganged setup.



Figure 13. Substation transformer with customer-specific coordination and accessories.



Figure 15. Class 1 Div 2 hazardous duty substation transformer.

Eaton
1000 Eaton Boulevard
Cleveland, OH 44122
United States
Eaton.com

Eaton's Cooper Power Systems Division
2300 Badger Drive
Waukesha, WI 53188
United States
Eaton.com/cooperpowerseries

© 2015 Eaton
All Rights Reserved
Printed in USA
Publication No. CA202004EN

Eaton is a registered trademark.

All other trademarks are property
of their respective owners.

For Eaton's Cooper Power series product
information call 1-877-277-4636 or visit:
www.eaton.com/cooperpowerseries.