

[1350.01 General](#)

[1350.02 Plans](#)

[1350.03 Traffic Control Systems](#)

[1350.04 Nearby Roadway Intersections](#)

[1350.05 Pullout Lanes](#)

[1350.06 Crossing Surfaces](#)

[1350.07 Crossing Closure](#)

[1350.08 Traffic Control during Construction and Maintenance](#)

[1350.09 Railroad Grade Crossing Petitions and WUTC Orders](#)

[1350.10 Grade Crossing Improvement Projects](#)

[1350.11 Light Rail](#)

[1350.12 Documentation](#)

[1350.13 References](#)

[Exhibit 1350-1 Sight Distance at Railroad Crossing](#)

[Exhibit 1350-2 Typical Pullout Lane at Railroad Crossing](#)

## 1350.01 General

Highway-rail grade crossings (“grade crossings”) are the intersection of two modes of transportation with very different physical and operational characteristics. Because of the inherent limitations associated with train operations, RCW 46.61.350 gives train traffic the right of way at grade crossings, thereby assigning motorists the primary responsibility to avoid collisions.

There are many variables that influence a motorist’s ability to react appropriately at grade crossings, including what information is available to them as they approach the crossing and human factors such as competing decisions, distractions, and impaired driving. Primary factors in the design of grade crossings are roadway and railway geometry; available sight distance; highway and railway speeds; competing decisions or visual distractions; and the types of warning devices at the grade crossing.

Another aspect of grade crossing design is coordination of highway traffic signal operations with grade crossing active warning devices (“railroad preemption”) when signalized intersections are located near grade crossings. In such instances, railroad preemption is designed to clear the tracks of any vehicles that may be stopped as a result of the highway traffic signal when a train is approaching the grade crossing. Further guidance on railroad preemption requirements is provided in [Chapter 1330](#).

Grade crossings are also unique due to their multijurisdictional nature. Highway authorities and railroad companies are each legally responsible for different elements at grade crossings. Additionally, the Washington Utilities and Transportation Commission (WUTC) is the state regulatory agency with oversight of public grade crossings in Washington, except within the limits of first class cities in accordance with [RCW 81.53.240](#). Establishing new crossings, altering existing crossings, or closing crossings all require WUTC approval. Therefore, highway projects that include a grade crossing will generally require close coordination with both the railroad company and the WUTC.

Projects that include grade crossings will generally require execution of construction and maintenance agreements between the Washington State Department of Transportation (WSDOT) and the railroad company. These agreements specify the design elements of the crossing, work that the railroad will perform on behalf of the project, payment terms, and legal provisions.

It may also be necessary for WSDOT to obtain easements from the railroad company for new grade crossings on railroad property. The Headquarters (HQ) Railroad Liaison is responsible for facilitating highway project coordination with railroad companies, including developing agreements and obtaining WUTC approvals. Obtaining necessary approvals from the railroad company may take several months.

Contact the HQ Railroad Liaison early in the design phase so that all necessary design and agreement coordination can be completed according to project schedules.

More information about general railroad coordination and WUTC requirements is provided in Chapter 3 of the *Utilities Manual*.

## 1350.02 Plans

### 1350.02(1) Proposed Improvements

Include plans for proposed improvements to existing crossings and any new crossings in the Plans, Specifications, and Estimates (PS&E) package. In addition to basic roadway dimensions, signs, and markings, indicate the angle of crossing; number of tracks; location of signals and other railway facilities (such as electrical/communications lines and control boxes); and the limits of property ownership by the railroad company at the crossing location.

For any project proposing to alter the horizontal or vertical alignment at a grade crossing, including grade separations, show the alignment and profile for both the railroad and the roadway for a minimum of 500 feet on all legs of the crossing. Show all other important features that might affect the safety, operation, and design of the crossing, such as nearby crossroads, driveways/entrances, buildings, and highway structures on the plans.

### 1350.02(1)(a) Sight Distance

A railroad grade crossing is comparable to the intersection of two highways where a sight triangle is kept clear of obstructions (including vegetation) and may be protected by a traffic control device. When designing for these locations, provide for both corner and clearing sight distance.

Corner sight distance allows a driver, traveling towards the crossing, to see an approaching train at a distance that allows the vehicle to stop in advance of the crossing. (see [Exhibit 1350-1](#), Case A).

Clearing sight distance allows a driver stopped at a crossing to see far enough down the tracks that they may decide to proceed and cross those tracks before a train, approaching at its maximum allowable speed, reaches the crossing (see [Exhibit 1350-1](#), Case B.)

For Cases A and B, the minimum distance for removing signs, brush and timber in the vicinity of the grade crossing that obstruct the view of an approaching train is 100 feet, measured along the tracks from the crossing.

Among the challenges associated with providing sight distance at railroad grade crossing locations are topography, seasonal crops or other vegetation, and structures or other obstructions in properties that the sight lines cross, including the railroad. Evaluate, with HQ Railroad Liaison, and document the need to install active devices (such as signals or signals and gates) at locations where the distances in [Exhibit 1350-1](#) cannot be provided or maintained over time. Contact the HQ Railroad Liaison to engage the subject railroad and the WUTC in the evaluation.

### 1350.02(1)(b) Highway Grade and Crossing Angle

Construct highway grades so that low-clearance vehicles do not hang up on tracks or damage them. (See [Chapter 1220](#) for information on vertical alignment at railroad grade crossings.) Whenever possible, design the roadway to cross grade crossings at right angles. If bicycle traffic uses the crossing (this can be assumed for most roads), provide a shoulder through the grade crossing at least as wide as the approach shoulder width. If a skew is unavoidable, wider shoulders may be needed to permit bicycles to maneuver to cross the tracks at right angles. See [Chapter 1520](#) for information on bikeways crossing railroad tracks. Consider installation of advance warning signs indicating the presence of a skewed crossing for crossings where engineering judgment suggests a benefit.

Include any engineering studies or sight distance measurements in the Design Documentation Package (DDP).

Exhibit 1350-1 Sight Distance at Railroad Crossing

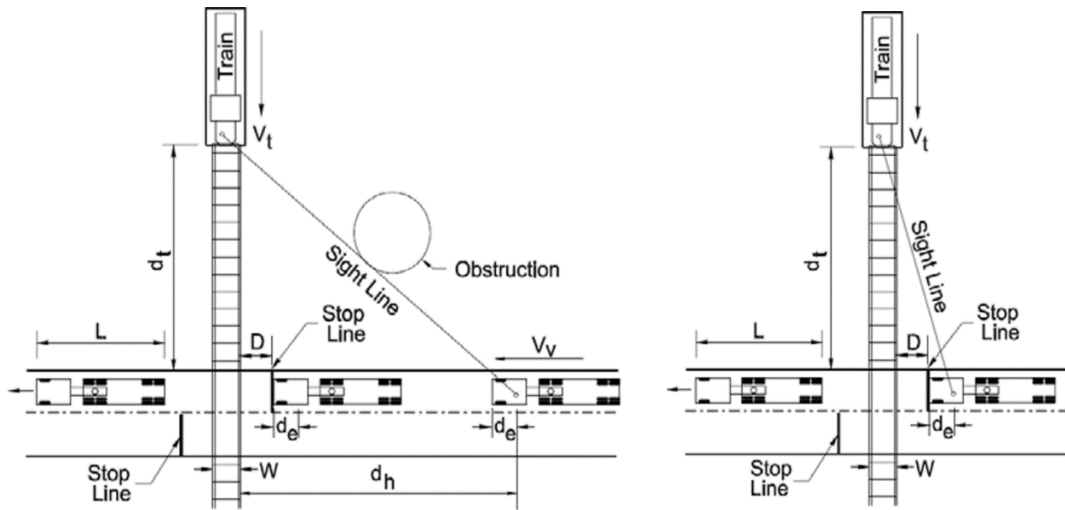

CASE A: Corner Sight Distance (Moving Vehicle)

CASE B: Clearing Sight Distance (Departure from Stop)

- dh = Sight distance along highway (ft)
- dt = Sight distance along railroad tracks (ft)
- de = Distance from driver to front of vehicle (8 ft)
- D = Distance from stop line to nearest rail (15 ft)
- W = Distance between outer rails (single track W=5 ft)
- Vv = Velocity of vehicle (mph)
- Vt = Velocity of train (mph)
- L = Length of vehicle (73.5 ft)

Notes:

- Adjust for skewed crossings.
- Assume flat highway grades adjacent to and at crossings.

Train Speed Vt (mph)	Case B: Departure from Stop (Feet) [1]		Case A: Moving Vehicle Vehicle Speed (mph) Vv						
	0	10	20	30	40	50	60	70	80
<b>Distance Along Railroad from Crossing dt (Feet) [1]</b>									
10	255	155	110	102	102	106	112	119	127
20	509	310	220	203	205	213	225	239	254
30	794	465	331	305	307	319	337	358	381
40	1,019	619	441	407	409	426	450	478	508
50	1,273	774	551	509	511	532	562	597	635
60	1,528	929	661	610	614	639	675	717	763
70	1,783	1,084	771	712	716	745	787	836	890
80	2,037	1,239	882	814	818	852	899	956	1,017
90	2,292	1,394	992	915	920	958	1,012	1,075	1,144
<b>Distance Along Highway from Crossing dh (ft)</b>									
		69	135	220	324	447	589	751	931

Design sight distance for a combination of highway and train vehicle speeds and a WB-67 (73.5-ft) truck crossing a single set of tracks at 90° (AASHTO).

Note: [1] Values shown in Case A and Case B are desirable. Refer to Section 1350.03(1)(a) for the minimum value.

Source: A Policy on Geometric Design of Highway and Streets, 2018, Table 9-29, page 9-167 by the American Association of State Highway and Transportation Officials.

## 1350.03 Traffic Control Systems

### 1350.03(1) Traffic Control System Elements

There are two categories of railroad warning devices: “passive” and “active.” Passive devices include all signs and pavement markings. Active devices include flashing light signals, railroad warning gates, and active advance warning systems, all of which are activated by approaching trains.

#### 1350.03(1)(a) Passive Elements

The following signing elements are shown in the MUTCD, Part 8, Traffic Control for Highway-Rail Grade Crossings:

- **Highway-Rail Grade Crossing (Crossbuck) sign:** Crossbuck signs identify the location of the grade crossing and convey the same meaning as a yield sign. The railroad is responsible for installation and maintenance of Crossbuck signs.

Note: Railroads are required to upgrade standard Crossbuck signs at passive grade crossings to “Crossbuck Assemblies” by December 31, 2019. Crossbuck Assemblies are Crossbuck signs mounted in conjunction with STOP or YIELD signs. Any projects that establish new passive crossings or result in reconstruction of passive crossings should include design of Crossbuck Assemblies. (See Chapter 8 of the MUTCD for additional guidance.)

- **Supplemental Number of Tracks (inverted “T”) sign:** This sign is mounted below the Crossbuck sign to indicate the number of tracks when two or more tracks are involved. The railroad is responsible for installation and maintenance of these signs.
- **Grade Crossing Advance Warning sign (W10 sign series):** The road authority is responsible for installation and maintenance of these signs.
- **Exempt sign:** This is a supplemental sign that, when authorized by the WUTC, may be mounted below the Crossbuck sign. When this sign is approved, certain classes of vehicles, otherwise required to stop before crossing the tracks, may proceed without stopping, provided no train is approaching. The road authority is responsible for installation and maintenance of these signs.
- **Do Not Stop on Tracks sign:** This sign is used where it is determined that additional emphasis is needed to remind motorists of this legal requirement, such as where nearby roadway intersections result in queuing back across the tracks. The road authority is responsible for installation and maintenance of these signs.

Pavement markings on all paved approaches are the responsibility of the road authority and consist of **RR Crossing** markings in accordance with the *Standard Plans*, **No Passing** markings, and **Pullout Lanes**, as appropriate.

Consider the installation of illumination at and adjacent to railroad crossings where an engineering study determines that better nighttime visibility of the train and the grade crossing is needed. For example, where:

- A substantial number of railroad operations are conducted at night.
- Grade crossings are blocked for long periods at night by slow-speed trains.
- Collision history indicates that drivers experience difficulty seeing trains during hours of darkness.

### 1350.03(1)(b) Active Elements

**Railroad Flashing Light Signals and Gates:** These are active devices intended to warn motorists of approaching trains and impose a stopping requirement. The railroad is responsible for installation and maintenance of these devices.

**Traffic Signal Interconnection (also known as “railroad preemption”):** These provide linkage between the railroad signals and adjacent traffic signals to allow vehicles to clear the tracks at a traffic signal as a train approaches. They are typically funded by the road authority and require cooperation with the railroad for installation. The formation of a Railroad Crossing Evaluation Team is required to determine signal railroad preemption requirements. (See [Chapter 1330](#) for further guidance.)

**Pre-Signals:** These are traffic control signal faces that control roadway traffic approaching a grade crossing in conjunction with the traffic control signal faces that control traffic approaching a roadway-roadway intersection beyond the tracks. Pre-signals are typically used where the clear storage distance is insufficient to store one or more design vehicles.

**Active Advance Warning Systems:** These are supplemental flashing yellow beacons mounted along with the grade crossing advance warning signs that are interconnected to the railroad active warning devices. Activation of the railroad active warning devices activates the beacons to provide motorists with an advance indication that a train is approaching or occupying the crossing. Active advance warning systems are typically used where roadway geometry prevents a clear view of the grade crossing ahead, or where higher highway speeds may require advance notification of an impending stopping requirement. Use a plaque stating “Train When Flashing” as part of such systems.

**Supplemental Safety Devices:** Supplemental safety devices are typically used at locations where it is known that motorists frequently drive around gates, where deemed appropriate due to unique local conditions, or as part of railroad quiet zones where trains are not required to sound the locomotive horn. (For more information about quiet zones, see <https://railroads.dot.gov/elibrary/quiet-zone-locations-city-and-state-1>.)

Typical supplemental safety devices include:

- **Four-Quadrant Gate Systems:** These are additional gates placed on the opposite side of the roadway from the primary railroad warning gates that, when lowered, make it impossible for motorists to drive around the lowered gates. (See Chapter 8 of the MUTCD for additional information on four-quadrant gate systems.)
- **Median Separators:** This is a system of raised delineators extending along the roadway centerline back from the tip of a lowered railroad warning gate that prevents motorists from being able to drive around the lowered gates. Make median separators at least 60 feet in length where sufficient space is available.

### 1350.03(1)(c) Selection of Grade Crossing Warning Devices

At a minimum:

- All public grade crossings are required to be equipped with Crossbuck signs, a supplemental plaque indicating the presence of multiple tracks (if applicable), and advance warning signs.
- Railroad pavement markings are required at all crossings where active warning devices are present or the posted legal speed limit is 40 mph or higher.

Passive warning devices notify drivers that they are approaching a grade crossing and to be on the lookout for trains. In general, consider stand-alone passive warning devices at grade crossings with low volumes and speeds on both the highway and railway, and where adequate sight distances exist.

Active warning devices are to be considered at all other crossings. No national or state warrants have been developed for installation of traffic control devices at grade crossings. Furthermore, due to the large number of significant variables that need to be considered, there is no single system of active traffic control devices universally applicable for grade crossings. Warning systems at grade crossings should be based on an engineering and traffic investigation, including input from the railroad and the WUTC. Primary factors to consider in selecting warning devices are train and highway volumes and speeds; highway and railway geometry; pedestrian volume; accident history; and available sight distance.

Evaluate railroad signal supports and gate mechanisms as roadside features to be considered for mitigation. Use traffic barrier or impact attenuators as appropriate (see Division 16).

#### **1350.04 Nearby Roadway Intersections**

Operations at roadway intersections located near grade crossings can present significant challenges for grade crossing safety. In particular, vehicle queues originating from the roadway intersection and extending back to the grade crossing must be clear of the tracks before the arrival of any trains. While RCW 46.61.570 prohibits motorists from stopping on any railroad tracks, it is not uncommon for motorists to stop on tracks when focusing on the downstream highway intersection rather than the immediate grade crossing.

For signalized highway intersections where vehicle queues result from a red signal indication, clearance of vehicles from the grade crossing is accomplished through traffic signal interconnection with the railroad warning signals (“railroad preemption”). When railroad preemption is in place, an approaching train will initiate a special mode within the highway traffic signal specifically designed to clear any vehicles from the tracks prior to the arrival of the train at the grade crossing. Railroad preemption design involves a specialized analysis that considers the distance between the roadway intersection and grade crossing; queue clearance times; train speeds; the capabilities of the railroad active warning devices; and other traffic signal phases.

Where the distance between the grade crossing and the roadway intersection is not sufficient to store a design vehicle, a pre-signal may be considered to prevent subsequent vehicles from entering the grade crossing limits during the track clearance phases of the downstream highway signal. Additionally, whenever a signalized roadway intersection is located 500 feet from a grade crossing, a Railroad Crossing Evaluation Team, which includes representatives from both WSDOT and the railroad company, will jointly determine the need for and design of railroad preemption systems. (See [Chapter 1330](#) for further guidance on railroad preemption requirements.)

Vehicle queues over the tracks can also result from operations at nonsignalized roadway intersections; for example, where there is a short distance between the grade crossing and a roadway intersection controlled by a STOP or YIELD sign. A “Do Not Stop on Tracks” sign should be installed at locations where the distance between the grade crossing and the roadway intersection is not sufficient to store a design vehicle or it is otherwise determined that vehicle queues originating from the roadway intersection routinely extend back to the grade crossing. To determine whether or not to consider a highway traffic signal in such instances, refer to MUTCD Traffic Signal Warrant 9.

#### **1350.05 Pullout Lanes**

In accordance with RCW 46.61.350, certain vehicles are required to stop at all railroad crossings unless the grade crossing is flagged or an “Exempt” sign is posted. Evaluate the installation of “pullout” lanes when grade crossings have no active protection. Some school districts have a policy that school buses must stop at all grade crossings regardless of the type of control.

Consider the installation of pullout lanes at any public grade crossing used regularly by school buses or by trucks transporting flammable cargo or explosives and at which they must stop.

Contact the local school district for school bus information. Contact the Truck Freight Program and Policy Manager at the WSDOT HQ Freight Systems Division about truck freight operations in the project vicinity.

Design pullout lane geometrics in accordance with Exhibit 1350-2. The minimum shoulder width adjacent to the pullout lane is 3 feet.

**Exhibit 1350-2 Typical Pullout Lane at Railroad Crossing**

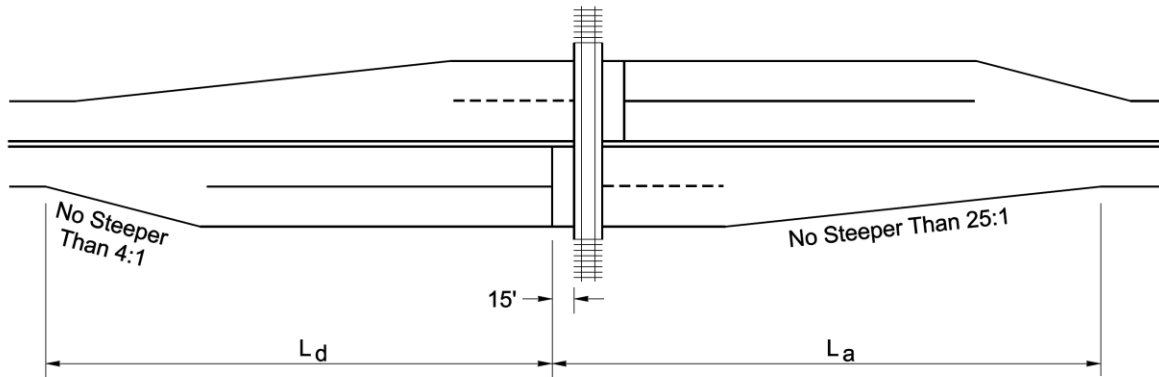

$L_d$  = Total length of pullout lane, approach

$L_a$  = Total length of pullout lane, exit

Approach Length of Pullout Lane, $L_d$		Downstream Length of Pullout Lane, $L_a$	
Vehicle Speed (mph)	Length (ft)	Vehicle Speed (mph)	Length (ft)
30	235	30	*
40	320	40	360
50	435	50	720
60	530	60	1,200

\*Taper length only

**1350.06 Crossing Surfaces**

Railroads are responsible for the maintenance of crossing surfaces up to 12 inches outside the edge of rail (WAC 480-62-225). Crossing surfaces can be constructed of a number of different materials, including asphalt, concrete, steel, timber, rubber, or plastic. The most common surface types used on state highway crossings are asphalt, precast concrete, and rubber. Timbered crossings are frequently used for low-volume roads and temporary construction crossings.

The life of a crossing surface depends on the volume and weight of highway and rail traffic using it. Highway traffic not only dictates the type of crossing surface, but it also has a major influence on the life of the crossing. Rough crossing surfaces impact the motoring public far more than the railroad. Therefore, when a highway project passes through a railroad grade crossing, consider the condition of the crossing surface. While the existing condition might not warrant railroad investment in replacing it, the surface might have deteriorated sufficiently to increase vehicle operating costs and motorist inconvenience.

In such cases, it may be effective to partner with the railroad to replace the crossing as part of the highway project. Such partnerships typically consist of the state reimbursing the railroad for all or a portion of the cost of the work.

### 1350.07 Crossing Closure

The MUTCD states, “Any highway-rail grade crossing that cannot be justified should be eliminated.” Coordination with the appropriate railroad and the Washington Utilities and Transportation Commission is required before any grade crossing can be closed. If a state route grade crossing appears unused, consult the HQ Railroad Liaison before taking any action. Close at-grade crossings that are replaced by grade separations.

### 1350.08 Traffic Control during Construction and Maintenance

Provide work zone traffic control for projects at highway-rail grade crossings, which need protection from train traffic. When highway construction or maintenance activities affect a railroad crossing, the railroad company must be notified at least ten days before performing the work (WAC 480-62-305(4)). Furthermore, whenever highway construction or maintenance crews or equipment are working within 25 feet of an active rail line or grade crossing, consult the railroad to determine whether a railroad flagger is required. Current contact numbers for railroads may be obtained by contacting your region Utilities Engineer or the HQ Railroad Liaison. Railroad flaggers differ from highway flaggers in that they have information on train schedules and can generally communicate with trains by radio. When flaggers are required, the railroad generally sends the road authority a bill for the cost of providing this service.

Do not allow work zone traffic to stop or queue up on a nearby rail-highway grade crossing unless railroad flaggers are present. Without proper protection, vehicles might be trapped on the tracks when a train approaches. (See the MUTCD for more detailed guidance.)

For projects requiring temporary access across a set of railroad tracks, contact the HQ Railroad Liaison early in the design process since a railroad agreement or permit will likely be required.

### 1350.09 Railroad Grade Crossing Petitions and WUTC Orders

The Washington Utilities and Transportation Commission (WUTC) is authorized by statute ([Title 81 RCW](#)) to have regulatory authority over railroad crossings. Establishing new crossings, closing existing crossings, or modifying existing grade crossings must be approved by the WUTC (WAC 480-62-150). WUTC authority does not apply within the limits of first class cities, in accordance with [RCW 81.53.240](#). This is accomplished by submitting a formal petition to the WUTC for a formal order. The HQ Railroad Liaison will assist in the preparation and submittal of this petition. Include a copy of the petition and WUTC findings and order in the Design Documentation Package.

### 1350.10 Grade Crossing Improvement Projects

The HQ Highways and Local Programs Office (H&LP) administers the federal (Section 130) Grade Crossing Safety Improvement Program. Project proposals are submitted by local agencies, railroads, and WSDOT.

Contact H&LP or the HQ Railroad Liaison in the Utilities, Railroads, and Agreements Section for more information.



## 1350.11 Light Rail

Light rail transit systems have been implemented and will continue to be developed in some urban areas of the state. For the most part, criteria for light rail transit crossings are very similar to those for freight and passenger rail with the exception of locations where light rail shares a street right of way with motor vehicles. The MUTCD now includes guidance devoted exclusively to light rail transit and can be consulted as the situation warrants.

## 1350.12 Documentation

For the list of documents required to be preserved in the Design Documentation Package and the Project File, see the Design Documentation Checklist: <https://wsdot.wa.gov/engineering-standards/design-topics/design-tools-and-support#Tools>

## 1350.13 References

### **1350.13(1) Federal/State Laws and Codes**

Revised Code of Washington (RCW) 81.53, Railroad crossings [apps.leg.wa.gov/rcw/default.aspx?cite=81.53](http://apps.leg.wa.gov/rcw/default.aspx?cite=81.53)

Washington Administrative Code (WAC) 480-62-150, Grade crossing petitions  
<http://apps.leg.wa.gov/wac/default.aspx?cite=480-62-150>

### **1350.13(2) Design Guidance**

[Agreements Manual](#), M 22-99, WSDOT (Consultants: Please contact your WSDOT Project Manager for access to the Agreements Manual)

Manual on Uniform Traffic Control Devices for Streets and Highways, USDOT, FHWA; as adopted and modified by Chapter 468-95 WAC “Manual on uniform traffic control devices for streets and highways” (MUTCD)  
[www.wsdot.wa.gov/publications/manuals/mutcd.htm](http://www.wsdot.wa.gov/publications/manuals/mutcd.htm)

Standard Plans for Road, Bridge, and Municipal Construction (Standard Plans), M 21-01, WSDOT  
[www.wsdot.wa.gov/publications/manuals/m21-01.htm](http://www.wsdot.wa.gov/publications/manuals/m21-01.htm)

### **1350.13(3) Supporting Information**

A Policy on Geometric Design of Highways and Streets (Green Book), AASHTO

Guidance On Traffic Control Devices At Highway-Rail Grade Crossings, Highway/Rail Grade Crossing Technical Working Group (TWG), FHWA, November 2002

[https://safety.fhwa.dot.gov/hsip/xings/com\\_roaduser/fhwasa18040/fhwasa18040v2.pdf](https://safety.fhwa.dot.gov/hsip/xings/com_roaduser/fhwasa18040/fhwasa18040v2.pdf)

Railroad-Highway Grade Crossing Handbook, FHWA, August 2007

Manual on Uniform Traffic Control Devices Part 8. Traffic Control for Railroad and Light Rail Transit Grade Crossings [mutcd.fhwa.dot.gov/htm/2009/part8/part8\\_toc.htm](http://mutcd.fhwa.dot.gov/htm/2009/part8/part8_toc.htm)