

CHAPTER 4

SLOPE DRAINAGE

4.1 General

Landslides and slope failures originate mostly from surface water and spring erosion. Proper drainage of surface and subsurface water is one of the most important aspects of maintaining stable road slopes.

According to the field visit along the N-M highway, the implemented slope drainage included horizontal drain hole works, roadside ditches and culvert boxes. The main problems relating to surface drainage and subsurface drainage are summarized as follows:

(1) Surface Drainage

- a) No any surface drainage facilities were constructed on the hill slope of the road, except for roadside ditches along the hillside of the road and culvert boxes cross the road. Because of no enough and proper surface drainage facilities, surface water erosion becomes more active; this causes considerably instability of road slopes.
- b) The section of roadside ditch and culvert box seems not to be determined according to hydrological calculation. When the section of culvert is not enough to discharge the collected surface water from roadside ditches, the surface water will overflow out of road surface and into the valley side of the road, eroding the valley slopes and consequently leading to collapse of road shoulders.

(2) Subsurface Drainage (horizontal drain hole work)

- a) Horizontal drain holes were just designed and executed on the lower slope of these landslide and unstable areas. In practice, drainage in the upper slope of a unstable area is more effective than in its lower slope.
- b) Horizontal drain pipes were not enough long to penetrate through the sliding surface. The main purpose of subsurface drainage is to remove the underground water around the sliding surface, thereby decreasing the pore pressure acting on the sliding surface.
- c) In some cases, drain pipes were terminated too short; this possibly allows the collected water to discharge onto the slope or the walls. Hence, erosion or collapse would be

caused again.

- d) Horizontal drain holes were terminated too short without outlet protection. This could cause the collected water to discharge onto the slope and again erosion and saturation of the slope could result

This chapter provides some basic hydrological calculation methods for design of slope drainage, introduces in detail the functions of varying surface drainage facilities, and discusses the design considerations of horizontal drain hole work.

4.2 Hydrological Analysis

As indicated above, if the road slope drainage or associated road drainage systems are not properly designed and maintained, then the surface runoff will overflow onto the roads. If this surface runoff is not drained in time, water may overflow to the downhill areas and cause serious road slope disasters. Slope drainage facilities should be designed to prevent both surface erosion and the collapse of soil slopes.

The surface drainage shall be designed with the following considerations: rainfall intensity, topography, ground surface conditions, soils, groundwater conditions, and existing drainage systems. The main factor in determining the capacities of drainage facilities is generally the runoff due to rainfall. The selection of the kind and sizes of the drainage facilities is based on hydraulic calculations.

4.2.1 Design Year of Rainfall Probability

The factor influencing the design of drainage facilities is mainly runoff due to rainfall, and its characteristics should be carefully examined. The other factors to be considered are the importance of the road and the expected degree of damage when actual runoff exceeds the expected design discharge. Therefore, the design year of rainfall probability shall be determined.

In case of Nepal, no any standard or criterion has been formulated yet on this matter. Table 4.2.1, as a reference, presents the recommended design year of rainfall probability. In addition, the required level of drainage may be determined in accordance with the importance of the road.

Table 4.2.1 Standard Probable Rainfall Return Period to be Applied

Degree of drainage capacity to be anticipated	Rainfall Return Period	
	(a)	(b)
High (National Highway & Strategic Road)	3 years	More than 10 years
Normal (Local Road)	2 years	7 years
Low	1 year	5 years

Notes: (a) is applied to ordinary drainage structures such as the ones on road surfaces and on small-scale slopes.

(b) is applied to important drainage structures, for example, drainage structures crossing roads and draining water from large natural slopes.

4.2.2 Calculation of Runoff

The calculation of runoff due to rainfall is based on the following Rational Method:

$$Q \text{ (m}^3\text{/sec)} = 0.2778 \times 10^{-6} \times f \times I_T \times a$$

Where, Q: Runoff (m³/sec)

f = Coefficient of runoff (referring to Tables 4.2.2),

I_T = Rainfall intensity within time of concentration (mm/h),

a = Catchment area (m^2),

Table 4.2.2 Coefficients of Runoff by Ground Surface Conditions

Ground surface condition		Coefficient of runoff
Road surface	Pavement	0.70 ~ 0.95
	Gravel road	0.30 ~ 0.70
Shoulder, slope, etc.	Fine-grained soil	0.40 ~ 0.65
	Coarse-grained soil	0.10 ~ 0.30
	Hard rock	0.70 ~ 0.85
	Soft rock	0.50 ~ 0.75
Grass on sandy soil	Gradient 0 to 2%	0.05 ~ 0.10
	Gradient 2 to 7%	0.10 ~ 0.15
	Gradient more than 7%	0.15 ~ 0.20
Grass on clayey soil	Gradient 0 to 2%	0.13 ~ 0.17
	Gradient 2 to 7%	0.18 ~ 0.22
	Gradient more than 7%	0.25 ~ 0.35
Ridges		0.75 ~ 0.95
Intermediate areas		0.20 ~ 0.40
Parks with abundant lawns and trees		0.10 ~ 0.25
Mountainous areas with gentle slopes		0.30
Mountainous areas with steep slopes		0.50
Paddy fields, water surface		0.70 ~ 0.80
Fields		0.10 ~ 0.30

Source: Modification Highway Earthwork Series, MANUAL FOR DRAINAGE WORKS, Published by Japan Road Association, June 1987.

The rainfall intensity within the time of concentration is empirically obtained from the following Monobe equation or from the rainfall intensity versus rainfall duration curve:

$$I_T \text{ (mm/h)} = R_{24}/24 \times (24/T)^{2/3}$$

Where, R_{24} = Daily rainfall (mm),

I_T (mm/h) = the mean rainfall intensity in a period of time T ,

T = Rainfall concentration time (hour)

The rainfall concentration time T can be estimated by the following Rziha formula:

$$T_a (\text{sec}) = 1/20 \times L / (H/L)^{0.6}$$

Where, L= Length of the rainfall path (m),

H= Difference of the elevation between the top of the catchment area and the end of the flood path (m).

Moreover, the mean flow velocity in the drainage facilities can be obtained from Manning formula as follows:

$$V (\text{m/sec}) = 1/n \times R^{2/3} \times S^{1/2}$$

Where, V (m/sec), mean velocity of flow,

S: hydraulic gradient of the drainage facilities

The design discharge, Q_d , of the drainage facilities is calculated as follows:

$$Q_d = A \times V$$

The design section of the drainage facilities should be more than 120% of the sectional area required to discharge the design storm in order to compensate for a reduction of cross-section area due to soil sedimentation in the drainage structures:

4.3 Surface Drainage

4.3.1 Classification Surface Drainage Facilities

The classification of the surface drainage facilities relevant to road cut slopes are as follows, and as shown schematically in Figure 4.3.1.

- a) Top slope drainage ditch
- b) Berm drainage ditch or horizontal drainage ditch
- c) Side drainage ditch
- d) Longitudinal drainage ditches

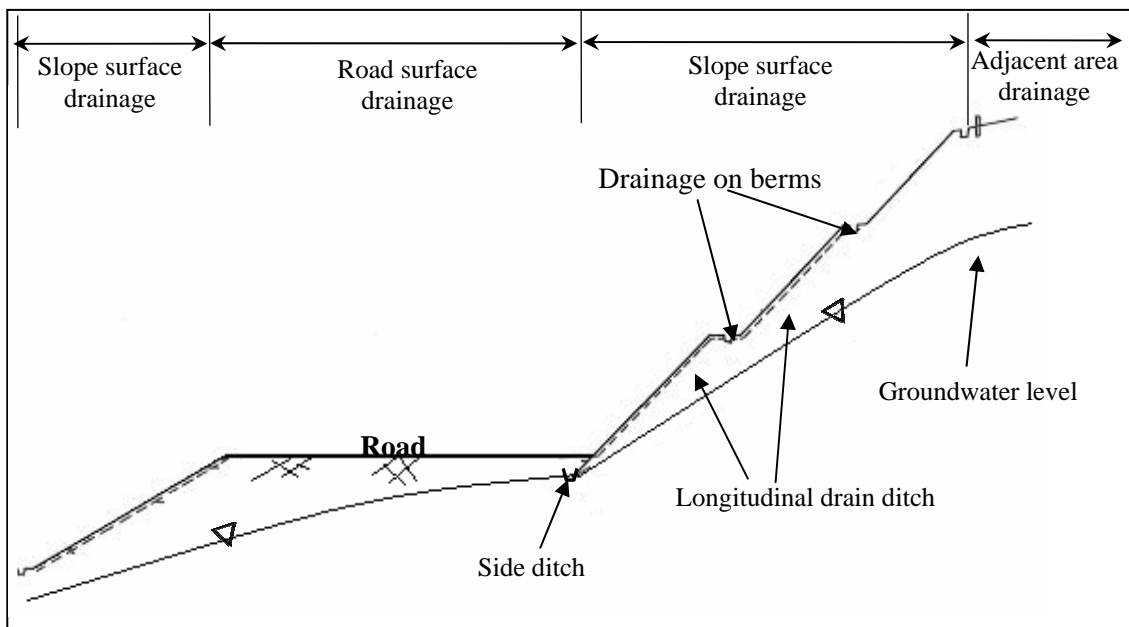

Figure 4.3.1 Classifications of Surface Drainage Facilities

Each drainage facility is discussed below:

4.3.2 Top Slope Drainage Ditch

Drainage ditches for the top of the slope shall be installed along the top of the slope to prevent flow of surface runoff from adjacent areas onto the slope.

The size of the ditch along the top of the slope shall be determined according to the amount of runoff due to rainfall. The ditches shall be constructed using soil cement mixture, stone pitching, etc. Figure 4.3.2 gives a structural image of a drainage ditch made with a soil cement mixture.

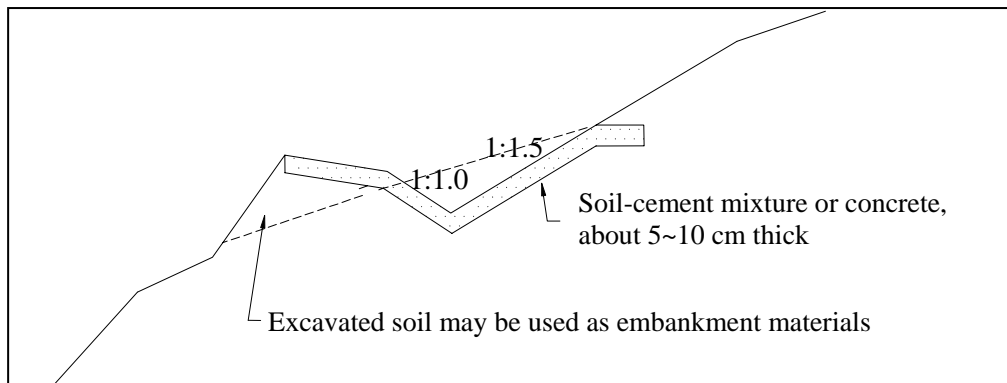

Figure 4.3.2 Drainage Ditch with Soil Cement Mixture

These ditches shall be installed close to the toe of the slope to prevent the flow of water at the back or sides of the ditch.

4.3.3 Horizontal Drainage Ditch

Horizontal drainage ditches or berm drainage ditches shall be designed to prevent slope surface erosion caused by rainfall or spring water.

The drainage ditches shall be constructed using soil cement mixtures, reinforced concrete U-shaped gutters, stone pitching, or be of the unsupported types. Figure 4.3.3 gives the structural image of a horizontal or berm drainage ditch.

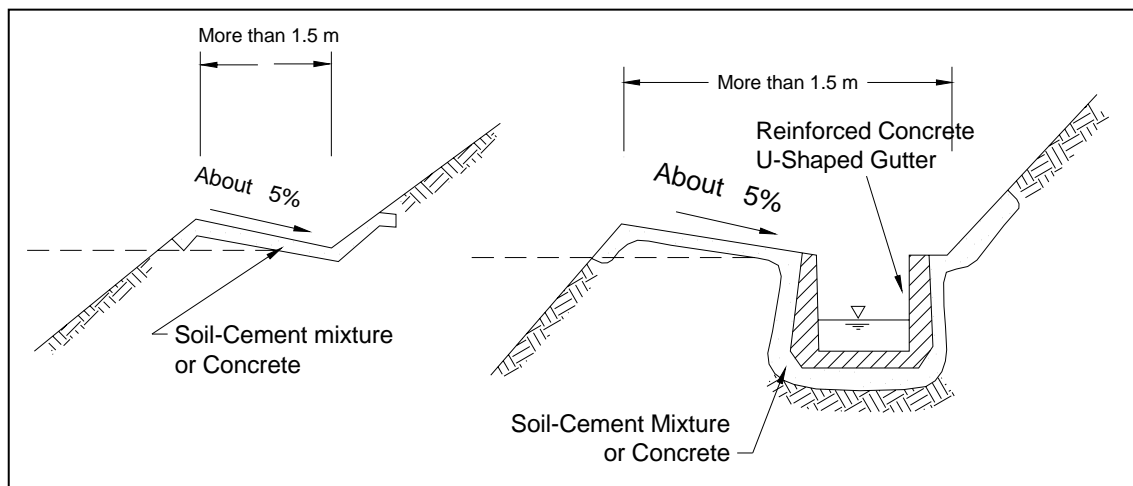

Figure 4.3.3 Details of Berm Drainage Ditches

When berm drains are provided, the width of the berm should be greater than 1.5m.

4.3.4 Side Drainage Ditch

Side drainage ditches shall be designed to cope with the maximum amount of the runoff from the

slope and adjacent.

The following types of ditches are generally used:

- a) Gravel ditch — It may be used where the discharge is less and there is enough space available.
- b) Stone pitching ditch — The bottom of the ditch is protected with boulder stones. This type is adoptable when the velocity of running water is a little faster.
- c) Stone masonry ditch — The ditch is covered with boulders at one or both sides, sometimes even the bottom. This type is recommendable for mountainous and rolling areas.
- d) Cast-in-place concrete ditch — Especially where the discharge is quite big and the velocity of the running water is fast, concrete ditch is recommended. Because of its bigger section, cast-in-place concrete ditch is usually used with cover.

4.3.5 Longitudinal Drainage Ditch

Longitudinal drainage ditches shall be designed to guide the water from a ditch at the top of a slope or berm to a proper channel at the toe of the slope.

The longitudinal drainage ditches are generally constructed using reinforced concrete U-shaped gutters, reinforced concrete pipes, or are stone-pitched (ladder type) channels. An example is shown in Figure 4.3.4.

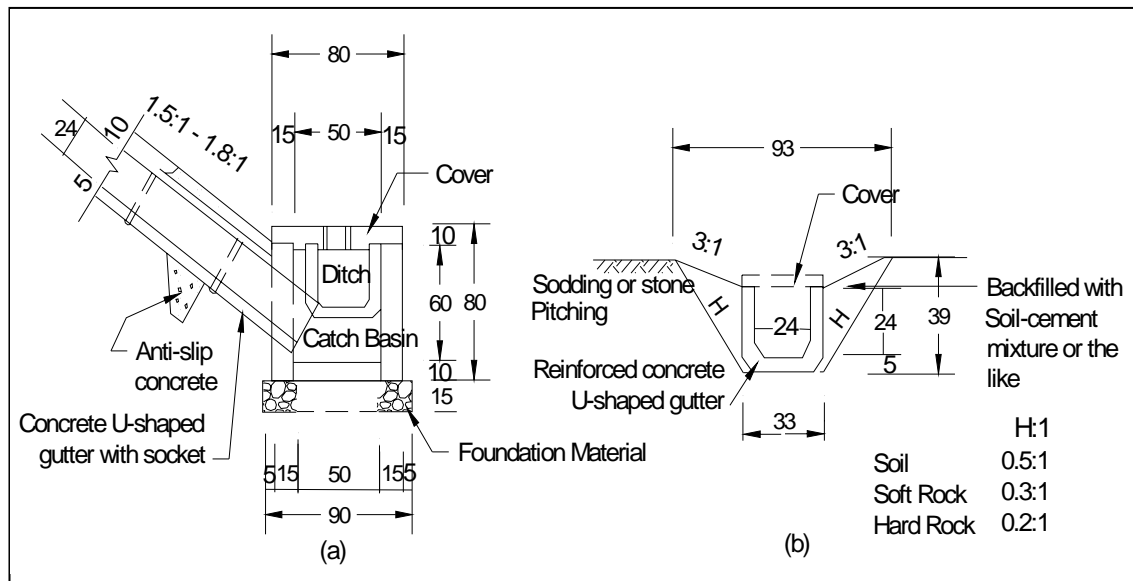

Figure 4.3.4 Structural Image of Drainage Ditch

At places where the direction of the flow changes drastically or where the longitudinal drainage ditch meets other waterways, a collecting basin with covers and simple sediment pit should be installed to reduce the energy of the running water. In principle, longitudinal drainage ditches are installed under the following conditions (Figure 4.3.5);

- a) Slopes are wider than 100 meters; and
- b) On valley-shaped slope, rainfall water is expected to flow in from the upper slope.

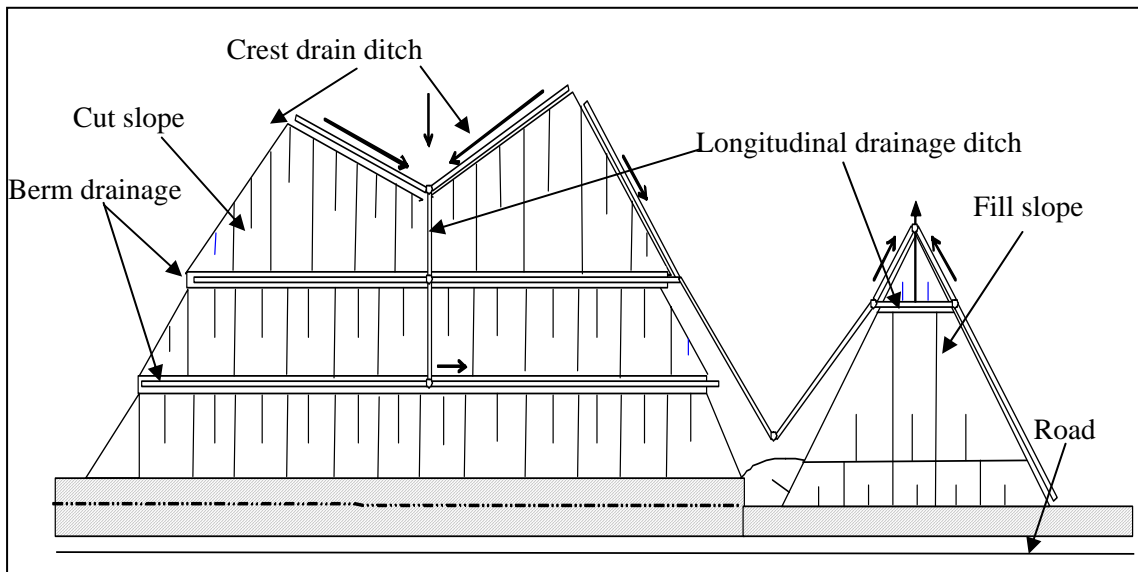

Figure 4.3.5 Example of Drainage Ditch Layout

4.4 Subsurface Drainage (Horizontal Drain Hole)

Groundwater is generally divided into two types, shallow and deep. Shallow groundwater, 0 to 5 meters below the ground surface, is due mainly to rainfall accumulated in the short-term. Shallow groundwater frequently causes a shallow failure or the toe failure of a large-scale landslide. In such cases, culverts and horizontal drain holes are effective.

4.4.1 Purpose

Horizontal drain holes are used to drain both shallow and deep groundwater to stabilize the landslide by decreasing the pore water pressure that is responsible for activating the sliding surface. The work is useful as a temporary countermeasure to decrease the progress of an active landslide.

4.4.2 Stability Analysis of Subsurface Drainage Effectiveness

Horizontal drain holes work is one of the most cost-effective methods of controlling a landslide. The amount of reduction in the pore water pressure that must be achieved through the construction of horizontal drain hole work in order to satisfy the proposed safety factor is obtained using Equation (3.4, See Formula. 3.1), as schematically shown in Figure 4.4.1.

$$\Delta U = \frac{1}{\tan \phi} (PF_s \times \sum T - \sum (N - U) \tan \phi - C \times \sum L) \dots\dots\dots (4.6)$$

Where,

ΔU (kN/m) = Assumed reduction in pore water pressure

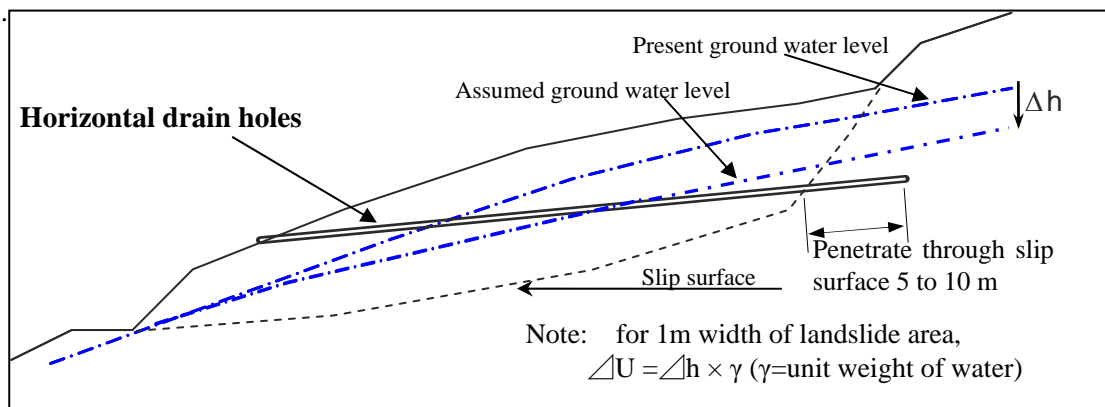

Figure 4.4.1 Schematic Diagram of Effectiveness of Horizontal Drain Hole

In the case of the standard-scale landslide with a landslide depth of 20 m, the reduction in the groundwater level by installation of horizontal drain holes may be expected to be 1 to 3 meters.

4.4.3 Design Consideration

Horizontal drain holes are constructed for the drainage of shallow groundwater and deep groundwater. If topography prevents the groundwater from being drained on a gentle gradient, then drainage wells or tunnels with horizontal drain holes shall be used to achieve drainage.

In designing horizontal drain holes, the following points should be carefully considered:

- a) Horizontal drain holes are used to discharge groundwater flowing down inside a landslide and groundwater flowing out of a landslide, and therefore, the work should be planned to place groundwater pathway, and possibly to place to catch groundwater before or just after running into slip surface. Usually they tend to be placed the upper slope of landslide area as a result.
- b) Horizontal drain holes interval should be 5 to 10 meters at drilling end.
- c) Horizontal drain holes should be designed to traverse aquifers or penetrate through the sliding surface 5 to 10 meters deep.
- d) Horizontal drain holes, generally 20 to 50 meters in length, should be excavated at a gradient of 5 to 10 degrees upwards for the purpose of fast removing the collected underground water.
- e) Hard polyvinyl chloride pipes (PVC) or gas pipes with an internal diameter of over 40 mm are used as casing pipes. Either the parts of the casing pipes traversing the aquifer or the whole length of the pipe is perforated to collect the underground water. Rigid pipes should be not used in a landslide or unstable area because a rigid pipe can not accommodate the landslide movement that is occurring in an area without separating at the joints.
- f) The collected groundwater by horizontal drain hole should be removed out of landslide or unstable areas using drain ditch or similar structures. Do not allow the collected water to discharge onto the landslide area again. Otherwise, erosion or rise of groundwater table could result again.
- g) Outlet protection for horizontal drain holes should be undertaken using gabions or concrete. Without outlet protection, erosion due to the collected water would be active and cause outlet collapse.

Effective layout of horizontal drain holes is shown in Figure 4.4.2.

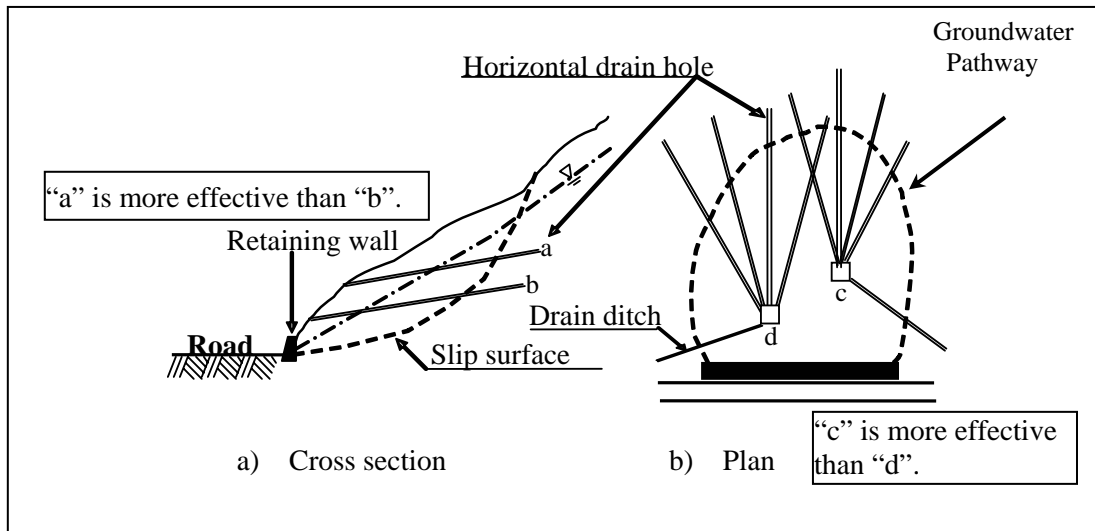

Figure 4.4.2 Effective Layout of Horizontal Drain Holes

CHAPTER 5

SLOPE PROTECTION WORKS

5.1 General

Slope protection works generally aim to eliminate or minimize erosion and/or weathering and to stabilize the unstable area of road slope with vegetation and/or structures. Structural slope protection works consist mainly of spraying, pitching, crib, retaining wall, rock bolt and anchor. These works can be used separately or with a combination of several works.

Along the N-M highway, the implemented slope protection works are mainly anchor work with concrete retaining wall, except for vegetation.

On the basis of the field visit and review of existing design documents, the main problems regarding to anchor work includes design and construction are as follows:

- a) The anchors were not perpendicular to the pressure bearing plates. Pedestals (anchor head block concrete) were designed, but not executed.
- b) Anchoring device (anchor nut) was fixed by welding.
- c) Anchoring device, pressure bearing plate and anchor bar were rusted.
- d) Fixation length of anchor in different locations (different geological conditions and different scale of unstable areas) was all the same.
- e) The anchors were not designed parallel to each other.
- f) Some anchors were pulled out from the pressure bearing plates.

This chapter mainly focuses on design and construction considerations regarding the following slope protection works:

- a) Crib work,
- b) Rock bolt work with crib work, and
- c) Ground Anchor work

The first two works were not constructed along the N-M highway, but are considered to be useful for development of mountainous road in the future. It is recommended that these works, as a new technology, should be introduced.

5.2 General Considerations

5.2.1 Classification of Crib Works

Crib works include precast concrete cribs, sprayed (concrete or mortar) cribs and cast-in-place concrete crib works. Their features are summarized in Table 5.2.1.

Table 5.2.1 Main Features of Crib Works

Type of crib works	Frame material	Advantage
Precast concrete crib	Precast concrete	1) Short construction period, 2) Good workability, 3) Good landscape
Sprayed crib	Concrete, mortar	1) Unified structure, 2) Flexible with an uneven slope surface, 3) Good adherence to ground surface
Cast-in-place concrete crib	Concrete	1) Superior bending strength than others, 2) Good adherence to ground surface

Precast concrete crib work offers little or no resisting force against the driving force of the unstable slopes, while shotcrete crib and cast-in-place concrete crib works have some resistance, depending on the size and space of the cribs.

(1) Precast Concrete Crib Work

Precast concrete crib work is generally applied at cut slope where erosion is intensive and re-vegetation is unsuitable. The target slope should be gentler than 1:1.0 (Vertical to Horizontal). The crib (or frame) usually ranges in size from 150 × 150 millimeters to 200 × 200 millimeters at intervals of about 1.0 meters. Anchor pins, 50 to 100 cm long, should be installed at each nodal point of the frames to prevent sliding of the frame. Figure 5.2.1 presents an example of precast concrete crib work.

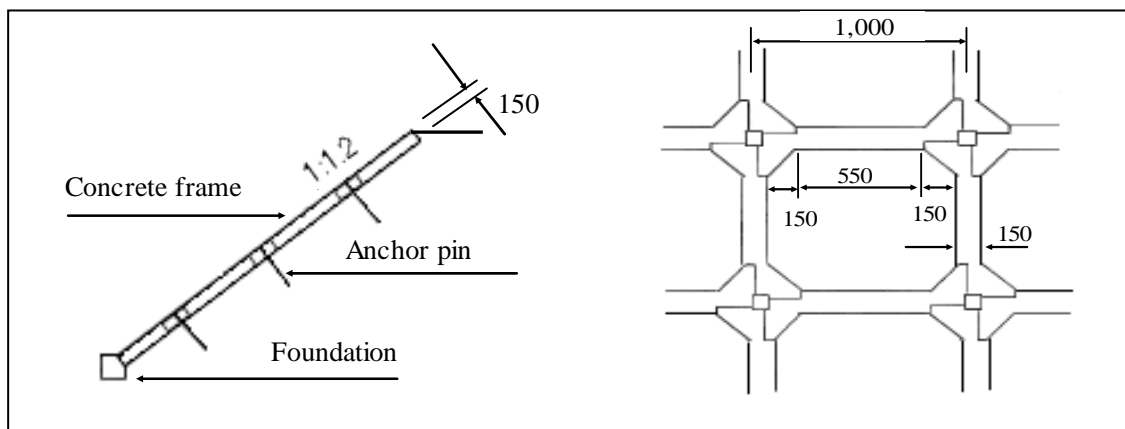

Figure 5.2.1 Example of Precast Concrete Crib Work

(2) Shotcrete Crib Work

Shotcrete crib work (or sprayed crib work) is used when the long-term stability of the slope is questionable, or when precast concrete crib work is unsuitable. The function of shotcrete crib work is the same as that of cast-in-place concrete crib work. The work can be applied for slopes with uneven slope surface. Moreover, the shape of cribs (frames) can be flexibly changed in accordance with the slope conditions.

Figure 5.2.2 gives the detail of shotcrete crib work.

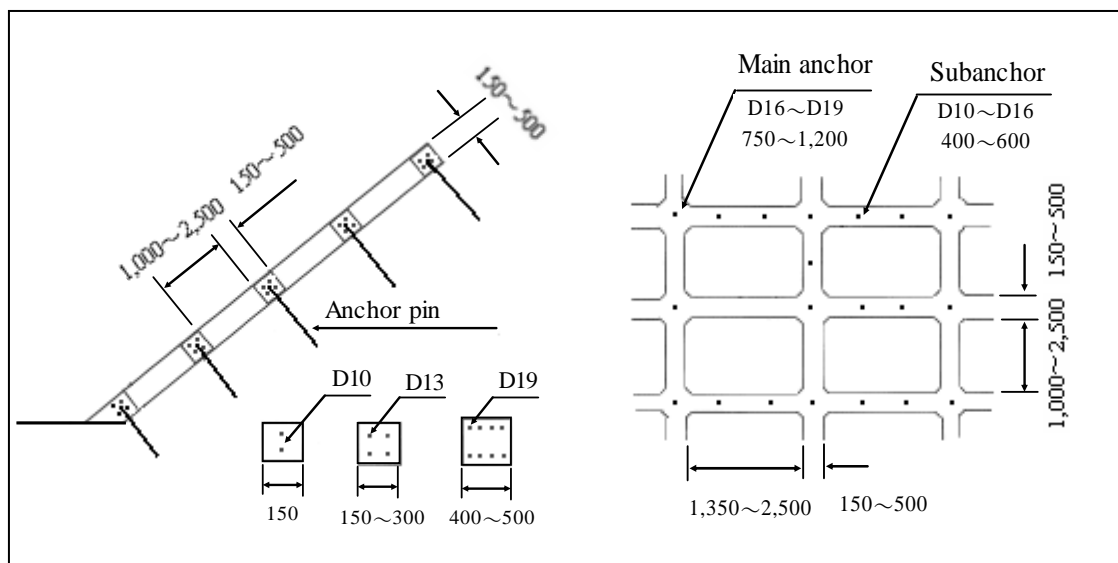

Figure 5.2.2 Details of Shotcrete Crib Work

The work is mainly applied to slopes with gradients of less than 1:0.8 (Vertical to Horizontal), to prevent further weathering of weathered or jointed rock faces and to stabilize small scale of collapse of about 1.0 m in thickness.

Moreover, the volumes of cement and water for the spraying admixture are generally determined to achieve a design standard strength of 150 kg/cm² (15 N/mm²) or higher.

(3) Cast-in-Place Crib Work

Similar to shotcrete crib work, cast-in-place concrete crib works are used when the long-term stability of the slope is questionable, or when concrete block crib work is likely to collapse on a large slope or on a slope of weathered and jointed rocks with spring water.

Figure 5.2.3 presents details of cast-in-place concrete crib work.

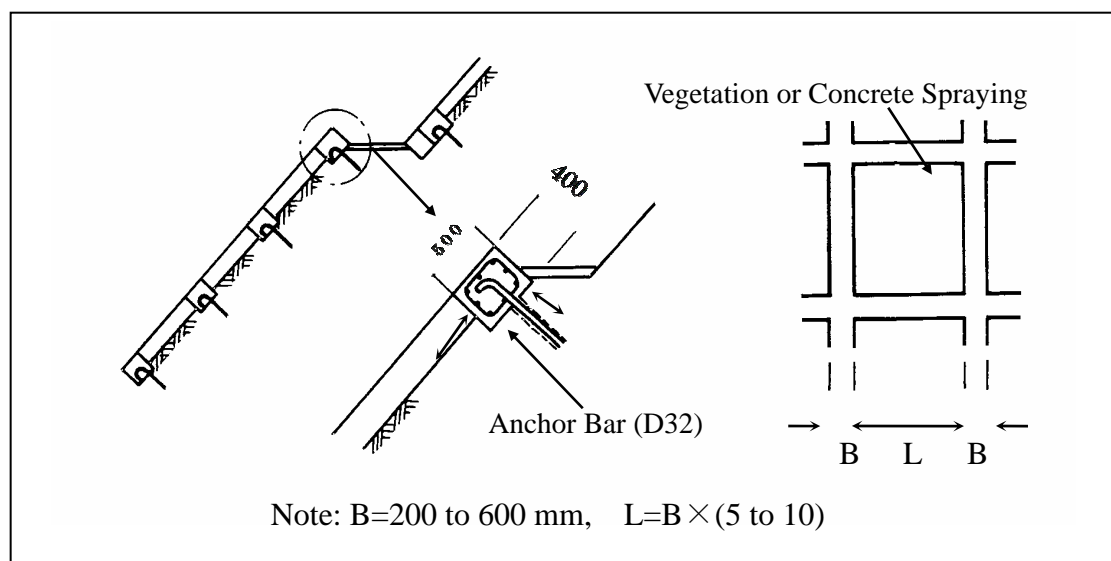

Figure 5.2.3 Details of Cast-in-place Concrete Crib Work

5.2.2 Expected Prevention Forces of Crib Works

They are commonly used on steep slopes of highly weathered or heavily jointed rocks with abundant springs, and chiefly applied to (a) prevent surface weathering, scouring and erosion, and in some cases, (b) control both rock fall and small-scale slope failure.

Precast concrete crib work offers little or no resisting force against the driving force of the unstable slopes, while shotcrete crib and cast-in-place concrete crib works have some resistance, depending on the size and space of the cribs. In addition, shotcrete crib and cast-in-place concrete crib works may be used jointly with rock bolt work (or reinforcing bar) or ground anchor to prevent different sizes of landslides or slope collapses, as shown in Table 5.2.2 and Figure 5.2.4.

Table 5.2.2 Expected Prevention Force of Crib Works

Work	Expected prevention force	Remarks
Crib work combined with ground anchor work	300 to 1,500 kN/m	Landslide, slope failure
Crib work combined with rock bolt work	50 to 300 kN/m	Shallow failure
Crib work (shotcrete and cast-in-place)	0 to 50 kN/m	Erosion, weathering

The crib (or frame) usually ranges in size from 200×200 millimeters to 600×600 millimeters at intervals of 2 to 5 meters. The spaces inside the cribs are filled and protected by stone pitching, mortar spraying, or vegetation, depending on the slope conditions (gradient, spring water, etc). Each intersection of the cribs is anchored with stakes or anchor bars.

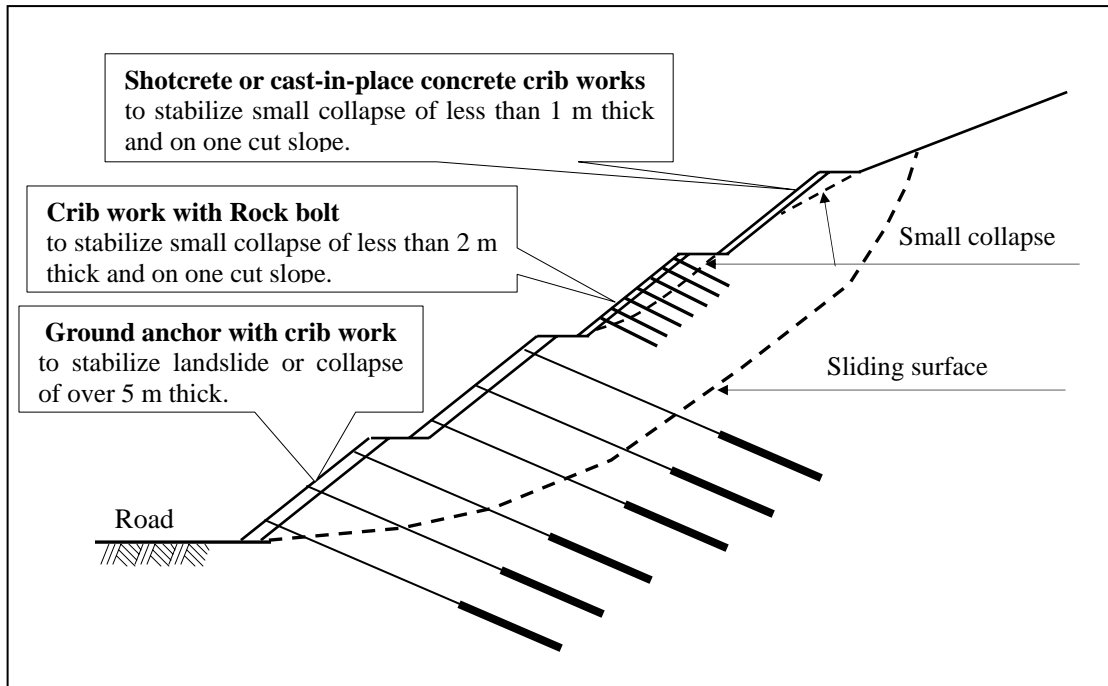

Figure 5.2.4 Conceptual Illustration of Crib Work Applications

5.3 Design and Construction of Crib Work

As described before, crib works include concrete block cribs, shotcrete cribs and cast-in-place concrete crib works. These are commonly used on steep slopes of highly weathered or heavily jointed rocks with abundant springs, especially where spalls cannot be fixed with shotcrete works.

5.3.1 Purpose

Crib works are chiefly applied to achieve the following purposes:

- a) Prevention of surface weathering, scouring and erosion, and
- b) Control of both rock fall and small-scale slope failure.

5.3.2 Design Consideration

The crib (or frame) usually ranges in size from 200 × 200 millimeters to 600 × 600 millimeters at intervals of 2 to 5 meters. The spaces inside the cribs are filled and protected by stone pitching, mortar spraying, or vegetation, depending on the slope conditions (gradient, spring water, etc). Each intersection of the crib is anchored with stakes or anchor bars. Table 5.3.1 shows the applications of crib works.

Table 5.3.1 Application of Crib Works

Type of crib works	Gradient (V:H)	Vertical height (m)	Condition of slope
Concrete block crib	Less than 1:0.8	Less than 5 m	Flat slope with spring water and large slope of gradient below 1:0.8
Shotcrete crib	Over 1:0.8	Less than 10 m	Slope of gradient above 1:0.8 and weathered or jointed rocks where spring water is present or where the soil is lacking in long-term stability
Cast-in-place concrete	Over 1:0.8	Less than 10 m	

Note: This table is only preliminary. Further detailed analysis is to be carried out by the engineer.

Source: Modification from Highway Earthwork Series, MANUAL FOR SLOPE PROTECTION, Published by Japan Road Association, March 1999.

5.3.3 Structural Calculation

(1) Scale and Model in Response to Shallow Failure

Crib work has less or no resistance to earth pressure, and therefore, is generally used to prevent small and local collapse, which is less than 1.0 m deep and 5.0 m long, as shown in the following figure. The model of shallow collapse is used for (a) stability analysis and (b) calculations of required preventive force.

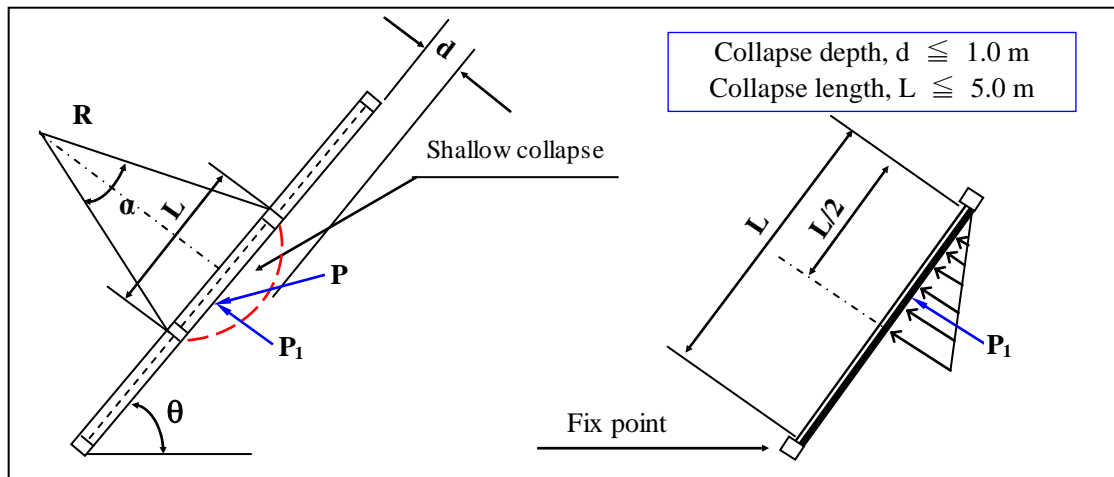

Figure 5.3.1 Scale and Model of Shallow Collapse for the Crib Work Design

(2) Calculation of Design Loads and Required Preventive Force

According to the mentioned-above model, the weight of crib (frame) is generally considered to be supported by surrounding cribs, and is thus excluded from structural load. Accordingly, the design load, W , is determined to be the sum of the weight, W_1 , of the assumed shallow collapse and the weight, W_2 , of the filled material inside cribs, as follows.

$$W = W_1 + W_2$$

The required prevention force, or the load acting on the longitudinal crib, P , will be obtained and calculated below:

$$P = (PF_s - F_o) \times W \times \sin \theta$$

$$P_1 = P \times \cos((180 - \alpha) / 2)$$

Where,

$W(\text{kN/m})$: Design load of unit width

$P(\text{kN/m})$: Load acting on the longitudinal crib in unit width

$P_1(\text{kN/m})$: Normal Component of loads acting the crib

F_o : Present factor of safety of assumed shallow collapse

PF_s : Planned factor of safety of assumed shallow collapse

θ ($^\circ$) : Inclination of cut or natural slopes to be protected

α ($^\circ$) : Central angle of circle collapse (shallow collapse)

The weight, W_1 , of shallow collapse mass in a longitudinal span is calculated as follows:

$$W_1 = \gamma_t \times \left\{ \frac{\alpha}{360} \times \pi \times R^2 - \frac{1}{2} L \times (R - d) \right\} \times @ \quad (\text{tf/span})$$

Where,

@ (m) : Vertical Interval of cribs, @=2.0 m

α ($^\circ$) : Central angle of circle collapse (shallow collapse)

R (m) : Radius of circle collapse (shallow collapse)

$$\alpha = 2 \times \sin^{-1} \times \frac{L}{2R} \quad (\text{Degrees})$$

$$R = \frac{1}{2d} \times (d^2 + \frac{L^2}{4}) \quad (\text{m})$$

In addition, by assuming that the filling material inside cribs is t m thick with a unit weight, γ_1 , its weight in a span, W_2 , is calculated below:

$$W_2 = A_3 \times t \times \gamma_1 \quad (\text{tf/span})$$

Where,

A_1 (m^2) : Crib covering whole area in a longitudinal span

A_2 (m^2) : Crib area in a longitudinal span

A_3 (m^2) : Area inside cribs in a longitudinal span

N : Number of cribs in assumed shallow collapse in the horizontal direction, N=4

$$A_1 = L \times @ \quad (\text{m}^2)$$

$$A_2 = (N \times @ + L) \times b - b^2 \times N \quad (\text{m}^2)$$

$$A_3 = A_1 - A_2 \quad (\text{m}^2)$$

The maximum differential distribution load, q , is calculated using the following equation:

$$q = \frac{4P_1}{L} \quad (\text{tf/span})$$

Where,

L (m) : is the width between cribs.

(3) Calculation of Moment and Force for Cribs

The model of design load is schematically shown in the following figure. The resultant force at fix points on the crib is calculated as follows:

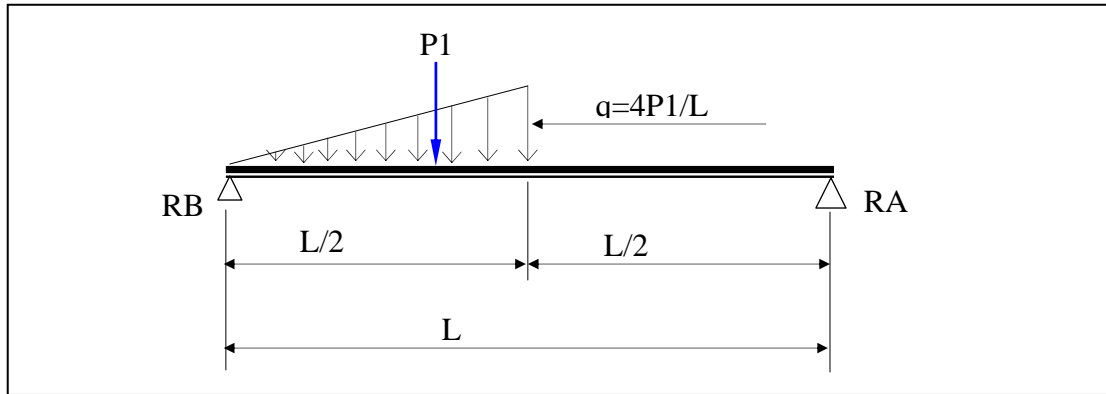

Figure 5.3.2 Model of Design Load

$$R_A = \frac{q \times L}{12} \quad (\text{tf/span})$$

$$R_B = \frac{q \times L}{6} \quad (\text{tf/span})$$

The maximum moment (M_{\max}) acting on the crib is calculated using the following formula:

$$M_{\max} = \frac{q \times L^2}{9 \times \sqrt{6}} \quad (\text{tf} \cdot \text{m})$$

The maximum shear force (S_{\max}) acting on the crib (or frame) is calculated using the following formula (refer to Figure 5.3.3):

$$S_{\max} = R_B = \frac{q \times L}{6} \quad (\text{tf})$$

(4) Determination of Crib Section

The standard cross section of the crib is shown in Figure 5.3.3. In this figure, b is the height of crib and d is the effective height of the selected steel, as shown in Table 5.3.2.

The required size (A_s) for the steel material is calculated using the following formula:

$$A_s = \frac{M_{max} \times 8}{\sigma_{sa} \times 7 \times d} \text{ (cm}^2\text{)}$$

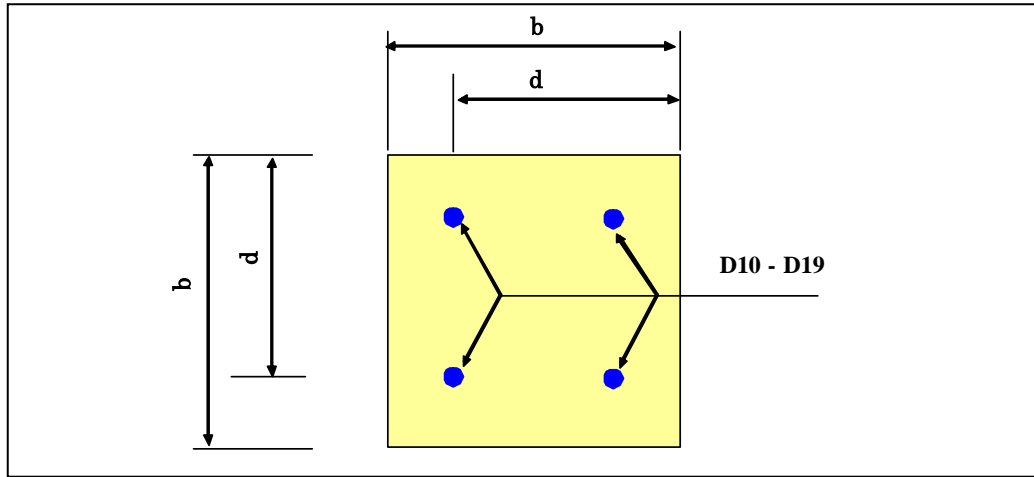

Figure 5.3.3 Cross Section of Concrete Crib (or Frame)

According to Table 5.3.2, after the selection of steel materials, their total sectional area, A_s' , is calculated and compared with the required size (A_s). The total sectional area should be bigger than the required size.

Table 5.3.2 Type and Size of Steel Material to Be Used for Concrete Crib

No.	Size of concrete grid	Nominal diameter	Weight (kgf/m)	Sectional area (cm ²) (A_s)	Number to be used for crib	Effective height (cm) (d)	Diameter (cm)
1	150*150	D10	0.56	0.7133	2	10.5	0.953
2	200*200	D10	0.56	0.7133	2	15.5	0.953
3	200*200	D10	0.56	0.7133	2	15.5	0.953
4	300*300	D13	0.995	1.267	2	23.5	1.27
5	300*300	D16	1.56	1.986	2	23.5	1.59
6	400*400	D13	0.995	1.267	4	31.5	1.27
7	400*400	D16	1.56	1.986	2	31.5	1.59
8	400*400	D16	1.56	1.986	4	31.5	1.59
9	500*500	D16	1.56	1.986	4	41.0	1.59
10	500*500	D19	2.25	2.865	4	41.0	1.91

The rate (p) of steel material in the concrete crib is calculated using the following formula:

$$p = \frac{A_s'}{b \times d}$$

The ratio (k) of distance between compressive plane and neutral axis with effective height is calculated using the following formula:

$$k = \sqrt{2 \times p \times n + (p \times n)^2} - p \times n$$

Where,

p : the rate (p) of steel material in the concrete crib

n : Ratio of Young's modules of steel and concrete (in general, n=15)

The ratio (j) is calculated using the following formula:

$$j = 1 - \frac{k}{3}$$

(5) Confirmation of Various Stresses for Steel Materials and Cribs

Table 5.3.3 summarizes the stresses to be confirmed and the related allowable stresses for steel materials and concrete cribs. The calculated stresses should be less than the allowable values.

Table 5.3.3 Allowable stresses of Steel materials and Concrete

Unit: kgf/cm²

Stress	Symbol	Value	Judgment
1.1 Allowable tensile stress of steel material	σ_{sa}	1,600.0	
1.2 Tensile stress of steel material	σ_s		
2.1 Allowable compressive stress for concrete	σ_{ca}	50.0	
2.2 Compressive stress for concrete	σ_c		
3.1 Allowable shear stress for concrete	τ_a	3.33	
3.2 Shear stress for concrete	τ		
4.1 Allowable adhesive stress between concrete and steel	τ_{ba}	13.00	
4.2 Adhesive stress between concrete and steel	τ_b		

The tensile stress (σ_s) of steel material is calculated using the following formula:

$$\sigma_s = \frac{M \max}{A_s \times j \times d} < \sigma_{sa}$$

The compressive stress (σ_c) of concrete crib is calculated using the following formula:

$$\sigma_c = \frac{2M \max}{k \times j \times b \times d^2} < \sigma_{ca}$$

The shear stress (τ) of concrete crib is calculated using the following formula:

$$\tau = \frac{S \max}{b \times j \times d} < \tau_a$$

The adhesive stress (τ_b) between the concrete grid and steel material is calculated using the following formula:

$$\tau_b = \frac{S \max}{U \times j \times d} < \tau ba$$

The total circum length, U, of steel material is as follows:

$$U=3.14 \times D \times \text{Nos}$$

Where,

D (cm) : Diameter of steel material (refer to Table 5.3.2)

Nos : Number of steel materials to be used for crib (refer to Table 5.3.3)

5.3.4 Notices in Construction

In constructing crib works, care should be given to the following points:

- a) The face of the slope should be finished flat so that members of the cribs are easily fixed to the slope, not to allow them to slip.
- b) Wire from each member should be tied with a stake or sub-anchor driven at each intersection of members and each hole is filled up with mortar for fixing. These stakes and subanchors should be 50 cm to 100 cm in length.
- c) Special precautions should be paid to prevent the sediment to runoff from the rear of the framing due to improper handling of spring water, and disengagement of filled materials in the framing due to insufficient compaction.
- d) Filling materials inside cribs should be carefully examined in consideration of the slope conditions. The filling materials mainly include stone pitching; block pitching, mortar spraying and vegetation.
- e) Framing joints should be anchored with a stake or pre-stressed steel bar for fixing. Framing may be partly embedded in or just laid on the slope.

5.4 Design and Construction of Rock Bolts with Crib Works

Where other works cannot meet the degree of safety required for a road slope, rock bolts with concrete crib work are used. The method is generally planned to cope with a small, shallow surface collapse of about 1 to 3 m in thickness.

Rock bolts with concrete crib work is similar to ground anchors in terms of function and design considerations.

5.4.1 Purpose

Rock bolts in association with concrete crib work are applied to stabilize a shallow surface collapse by exerting a force - the increased resisting power against shear force by the tension force of the rock bolts. The rock bolts with concrete crib work keeps the overall slope together, consequently preventing local collapse.

5.4.2 Design Considerations

Design considerations for rock bolts with concrete crib work include 1) Stability analysis and calculation of required preventive force; 2) Design of the rock bolts; 3) Design of the concrete crib; and 4) Design of the bearing plates.

They are discussed in detail below:

5.4.3 Stability Analysis and Calculation of Required Preventive Force

Stability analysis is conducted using the Swedish slice method. Parameters for the stability analysis are generally estimated on the basis of visual soil observations, as given in Table 5.4.1.

In a unit width, the prevention force (P_R) required for stabilizing the potential local collapse is calculated using the following equation

$$P_R = PF_s \times \Sigma T - (\Sigma N \times \tan \phi + C \times \Sigma L)$$

Where,

P_R (kN/m) = Required preventive force

PF_s = Proposed safety of factor

N (kN/m) = Normal force attributable to gravity of the slice, $N=W \cdot \cos\alpha$

T (kN/m) = Tangential force attributable to gravity of the slice, $T=W \cdot \sin\alpha$

U (kN/m) = Pore water pressure acting on the base of the slice

L (m) = Length of sliding (or collapse) surface acting on the slice

C (kN/m²)= Cohesion of sliding (or collapse) surface

ϕ degree= Internal friction angle of sliding (or collapse) surface

Table 5.4.1 Recommended Internal Friction Angle and Cohesion

Material	State	Unit Weight (kN/m ³)	Internal friction angle (Degrees)	Cohesion (kN/m ²)	Group symbol ¹⁾
Gravel	Dense and well graded	20	40	-	GW, GP
	Not dense, poorly graded	18	35	-	
Gravelly sand	Dense	21	40	-	GW, GP
	Not dense	19	35	-	
Sand	Dense or well graded	20	35	-	SW, SP
	Not dense or poorly graded	18	30	-	
Sandy soil	Dense	19	30	-	SM, SC
	Not dense	17	25	-	
Clayey soil	Firm	18	25	Less than 50	ML, CL
	Slightly soft	17	20	Less than 30	
	Soft	16	15	Less than 15	
Clay and silt	Firm	17	20	Less than 50	CH, MH, ML
	Slightly soft	16	15	Less than 30	
	Soft	14	10	Less than 15	

Note: 1) Group symbols of the Unified Soil Classification System.

2) 1 tf/m³ = 10 kN/m³, 1 tf/m² = 10 kN/m²

Source: Modification from DESIGN GUIDE – EARTHWORKS, Published by Japan Highway Public Corporation, May 1998.

5.4.4 Design of Rock Bolts

The design tensile force (T_d) for one rock bolt is calculated using the following equation:

$$T_d = \frac{P_R}{\sin(\alpha + \beta) \cdot \tan \phi + \cos(\alpha + \beta) \times \lambda} \cdot \frac{B}{N_1}$$

Where,

P_R (kN/m²) = Required preventive force

α (degrees) = Inclination of the target slope

β (degrees) = Angle of slope of collapse surface

ϕ (degrees) = Internal frictional angle of collapse surface

B (m) = Interval between rock bolts in horizontal direction

N1= Number of steps for rock bolt installation (nos) (=L/w)

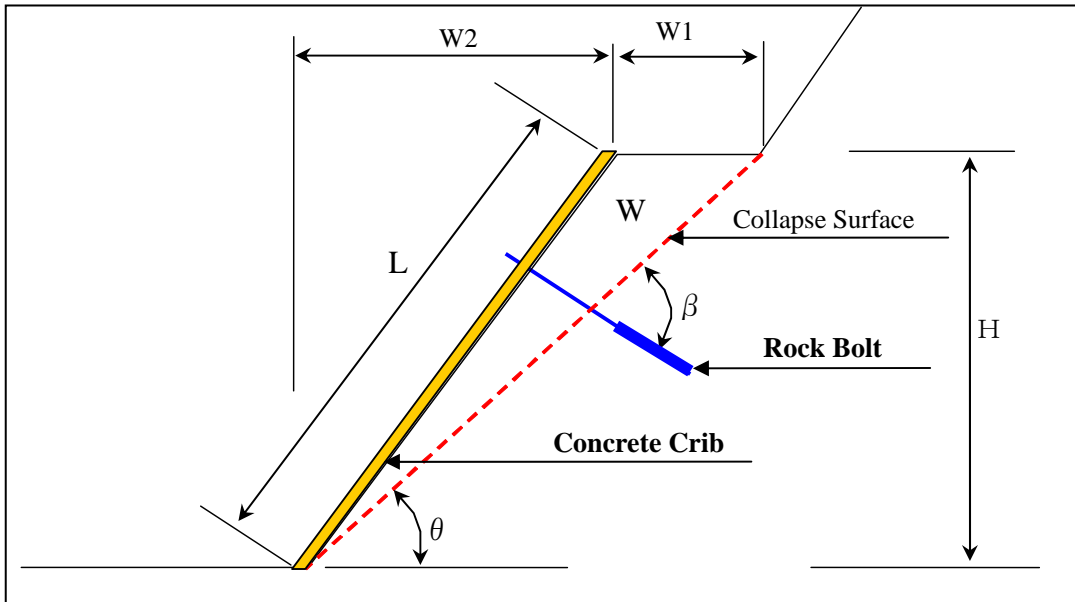

Figure 5.4.1 Model of Soil Slope Collapse and Arrangement of Rock Bolts

The tensile stress (σ_s) required against the tensile force of the rock bolt is calculated using the following formula:

$$\sigma_s = \frac{Td}{A_s} < \sigma_{sa}$$

Where,

A_s (cm²) = Section area of steel material.

Table 5.4.2 Allowable Tensile Stress (σ_{sa}) of Rock Bolt Material (Unit: N/mm²)

Type of steel	SR235	SR295	SD295AB	SD345	SD390
In normal case	140	160	180	200	210
In case of corrosion	120	140	160	180	190

Shear force (T_s) acting on one rock bolt shall be calculated using the following formula:

$$T_s = \frac{P_R \times B}{N_1}$$

The shear stress ($\sigma_{\tau a}$) required against the tensile force of the rock bolt is calculated using the following formula:

$$\sigma\tau a = \frac{T_s}{A_s} < \tau_{sa} = 80 \text{ N/mm}^2$$

For the design tensile force (Td) of a rock bolt to meet the allowable tensile force, the length of contact between the ground and grout is compared with that between the steel material and the grout. Whichever is greater is used as the fixed length (La).

The length (La1) of contact between the steel material and the grout is calculated as follows:

$$La1 = \frac{Td}{\pi \times d \times \tau_{ca}}$$

Where,

d (mm) = Diameter of rock bolt

τ_{ca} (N/mm²) = Allowable bond stress between the grout and the steel

Table 5.4.3 Allowable Bond Stress between the Grout and Steel Material

Type of steel	Design standard strength (N/mm ²)			
	18	24	30	More than 40
Different shape	1.4	1.6	1.8	2.0

Source: Modification from Highway Earthwork Series, MANUAL FOR SLOPE PROTECTION, Published by Japan Road Association, March 1999.

The length (La2) of contact between the ground and the grout is calculated as follows:

$$La2 = \frac{Td \times f}{\pi \times D \times \tau}$$

Where,

D (mm) = Diameter of Drilling Borehole

τ (N/mm²) = Friction resistance of ground

f = Safety factor for rock bolts (generally f = 2.0)

Table 5.4.4 Friction Resistance of Ground with Rock Bolt

Ground Type		Friction resistance (N/mm ²)	
Rock	Hard Rock	1.2	
	Soft Rock	0.8	
	Weathered Rock	0.5	
	Semi-Consolidated Soil	0.5	
Sand and Gravel Layer	N-Value	10	0.08
		20	0.14
		30	0.20
		40	0.28
		50	0.36
Sand Layer	N-value	10	0.08
		20	0.14
		30	0.18
		40	0.23
		50	0.24
Cohesive Soil		0.8*C (C: Cohesion)	

Note: 1 tf/m² = 0.01 N/mm².

Source: Modification from Highway Earthwork Series, MANUAL FOR SLOPE PROTECTION, Published by Japan Road Association, March 1999.

5.4.5 Design of Crib Works

Since concrete crib work offers little resisting force against the driving force of the soil slope collapse, each intersection of the crib is anchored with a rock bolt, as shown in Figure 5.4.2. The model of the design load is schematically shown in Figure 5.4.3.

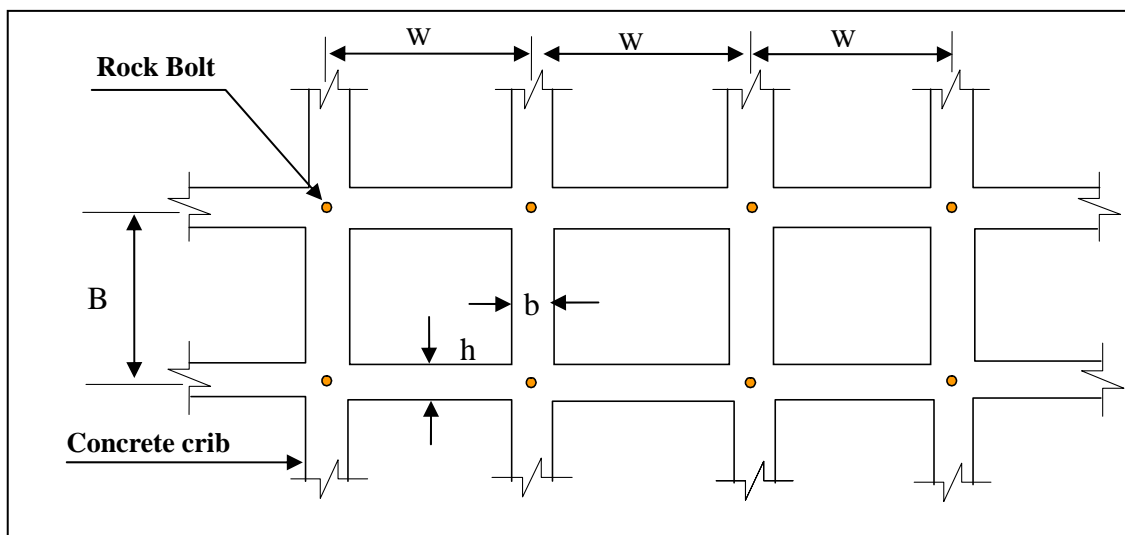

Figure 5.4.2 Arrangement of Rock Bolts

Since the concrete crib is hard in comparison with the ground soil, the design load acting on the

concrete crib is considered to be uniformly distributed. Accordingly, the design load (q) for one rock bolt is calculated as follows:

$$q = \frac{Td \times b}{(B + W - b) \times h}$$

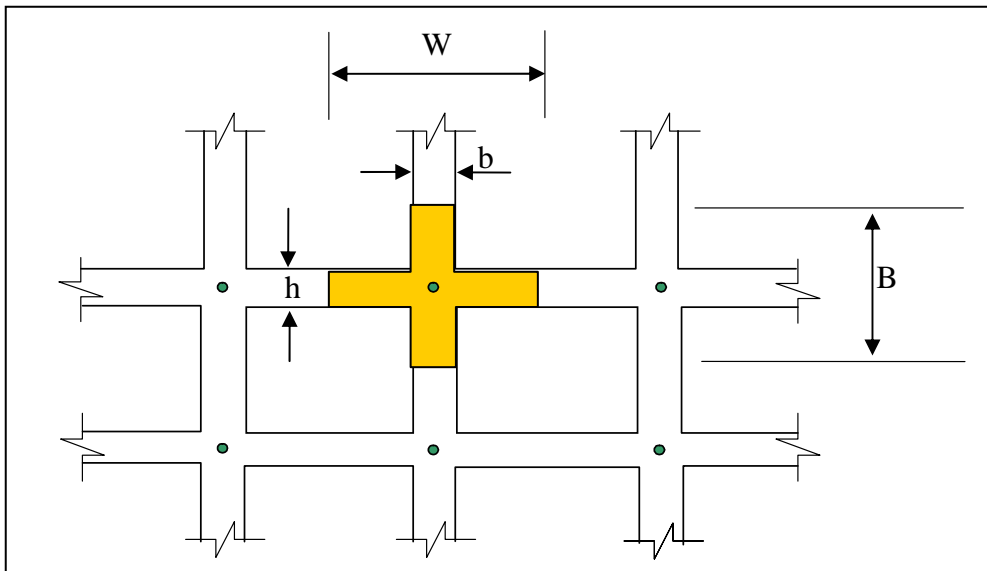

Figure 5.4.3 Model of Design Load

The maximum moment (M_{max}) acting on the concrete crib is calculated using the following formula:

$$M_{max} = \frac{q \times B \times W}{9}$$

The maximum shear force (S_{max}) acting on the concrete crib (or frame) is calculated using the following formula:

$$S_{max} = \frac{q \times B \times 3}{5}$$

The required size (A_s) for the steel material is calculated using the following formula:

$$A_s = \frac{M_{max} \times 8}{\sigma_{sa} \times 7 \times d}$$

The sectional area (A_s) and effective height (d) of steel material is given in Table 5.4.5.

Table 5.4.5 Type and Size of Steel Material Used for Different Concrete Cribs

No.	Size of Concrete Crib	Nominal Diameter	Weight (kgf/m)	Sectional Area (cm ²) (As)	Number to be Used for the Crib	Effective Height (cm) (d)	Diameter (cm)
1	150*150	D10	0.56	0.7133	2	7.5	0.953
2	200*200	D10	0.56	0.7133	2	15.5	0.953
3	200*200	D10	0.56	0.7133	2	15.5	0.953
4	300*300	D13	0.995	1.267	2	23.5	1.27
5	300*300	D16	1.56	1.986	2	23.5	1.59
6	300*300 with stir-lap	D16	1.56	1.986	2	23.5	1.59
7	400*400 with stir-lap	D16	1.56	1.986	4	31.5	1.59
8	400*400 with stir-lap	D16	1.56	1.986	4	31.5	1.59
9	500*500 with stir-lap	D19	2.25	2.865	4	41.0	1.91
10	600*600 with stir-lap	D22	3.04	3.871	4	51.0	2.22

Note: No. 2 = 1500*1200, No. 3= 1200*1200.

The ratio (p) of the steel material in the concrete crib is calculated using the following formula:

$$p = \frac{As'}{b \times d}$$

Calculation of the ratio (k) of the distance between the compressive surface and neutral axis to the effective height is calculated using the following formula:

$$k = \sqrt{2 \times p \times n + (p \times n)^2} - p \times n$$

Where,

p : the rate (p) of steel material in the concrete crib

n : Ratio of Young's modulus of steel and concrete (in general, n=15)

The ratio (j) is calculated using the following formula:

$$j = 1 - \frac{k}{3}$$

The tensile stress (σ_s) of the steel material is calculated using the following formula:

$$\sigma_s = \frac{M \max}{A_s \times j \times d} < \sigma_{sa}$$

The compressive stress (σ_c) of the concrete crib is calculated using the following formula:

$$\sigma_c = \frac{2M \max}{k \times j \times B \times d^2} < \sigma_{ca}$$

The shear stress (τ) of the concrete crib is calculated using the following formula:

$$\tau = \frac{S \max}{b \times j \times d} < \tau_a$$

The adhesive stress (τ_b) between the concrete crib and the steel material is calculated using the following formula:

$$\tau_b = \frac{S \max}{U \times j \times d} < \tau_{ba}$$

Table 5.4.6 Allowable Stress for Concrete (Mortar) Crib

1. Design standard strength (N/mm ²),	15
2. Allowable compressive stress (N/mm ²) σ_{ca}	5
3. Allowable shear stress (N/mm ²) τ_a	0.33
4. Allowable adhesive stress (N/mm ²) τ_{ba}	1.3

Source: Modification from GUIDELINE FOR DESIGN AND EXECUTION OF CRIB WORK, Published by Japan Slope Protection Association, March 1991.

5.4.6 Design of Bearing Plates

The size (B) of the bearing plate is dependent on the allowable compressive stress, and is calculated using the following formula:

$$B \geq \sqrt{\frac{Td}{\sigma_{ca}}} + a$$

$$\sigma_{ca} \geq 0.3 \times \sigma_{ck}$$

Where,

B = the minimum width required (mm)

Td = Design tensile force for one rock bolt (kN/nos)

σ_{ca} = Allowable compressive stress (N/mm²)

σ_{ck} = Design standard strength (N/mm²)

a = hole area (mm²)

5.4.7 Notices in Construction

Notices of construction are basically same as those described before, in Section 5.3.4.