

Constructing Our Future



Bechtel Rigging Handbook (Second Edition)



Bechtel Equipment Operations, Inc.



BECHTEL RIGGING HANDBOOK

2nd Edition

Copyright 1996, 2002 Bechtel Corporation
Second Edition. All rights Reserved.

No parts of this publication may be reproduced in any form without the prior written or expressed permission of the publisher.

Printed in the United States of America.

Written & Compiled By: The Bechtel Equipment Operations Rigging Department



Contents

1. Rigging Procedures and Safety	1-3
1.1 RIGGING PROCEDURES	1-3
1.1.1 General	1-3
1.1.2 Corporate References	1-3
1.1.3 Definitions	1-4
1.1.4 Responsibilities	1-7
1.1.5 Requirements	1-8
1.2 RIGGING SAFETY	1-9
1.2.1 General	1-9
1.2.2 Occupational Safety and Health Administration (OSHA) Safety Regulations	1-9
1.3 AMERICAN NATIONAL STANDARD INSTITUTE (ANSI) SAFETY CODES .	1-12
1.3.1 Responsibilities	1-14
1.3.2 Hand Signals	1-19
2. Basic Engineering Principles	2-3
2.0 INTRODUCTION	2-3
2.1 TRIGONOMETRIC FUNCTIONS	2-3
2.3 SLINGS	2-7
2.3.1 Basket Hitches and D/d	2-8
2.3.2 Sling Angle	2-9
2.3.3 Bridles and Center of Gravity	2-9
3. Cranes	3-1
3.1 INTRODUCTION	3-3
3.2 MOBILE CRANES	3-3
3.3 CARRIERS	3-5
3.4 FIXED, STATIC-BASED CRANES	3-7
3.5 AVAILABLE CRANE COMBINATIONS—TELESCOPIC BOOMS	3-11
3.5.1 Rough Terrain Cranes	3-11
3.5.2 All Terrain Cranes	3-13
3.5.3 Truck-Mounted Telescopic Cranes	3-16
3.5.4 Lattice Boom Truck Cranes	3-18
3.5.5 Crawler-Mounted Lattice Boom Cranes	3-20
3.6 SPECIAL CRANE ATTACHMENTS	3-22
3.6.1 Tower Attachment	3-22
3.6.2 Ringer Attachment	3-24
3.6.3 Superlift/Maxilift Attachments	3-24
3.6.4 Sky Horse Attachments	3-27
3.6.5 Lampson Transi-Lift	3-27

3.7 MOBILE CRANE STABILITY AND LOAD RATINGS	3-30
3.7.1 Tipping Load and Conditions	3-30
3.7.2 Tipping Load	3-30
3.7.3 Tipping Fulcrum Location for Crawler Cranes	3-31
3.7.4 Tipping Fulcrum for Truck and Hydraulic Cranes on Outriggers	3-33
3.7.5 Tipping Fulcrum for Truck and Hydraulic Cranes on Tires	3-35
3.7.6 Crane Loads to the Supporting Surfaces	3-37
3.7.7 Center of Gravity Calculation	3-38
3.8 CRANE REACTIONS	3-41
3.8.1 Crawler Crane Reactions	3-41
3.8.2 Crawler Crane Example	3-42
3.8.3 Truck Crane	3-48
3.9 MATTING	3-51
3.9.1 Distribution of Crane Loads to the Supporting Surfaces	3-51
3.9.2 Truck Crane	3-51
3.9.3 Crawler Crane	3-52
3.10 TOWER CRANE SUPPORT AND FOUNDATION REQUIREMENTS	3-55
3.10.1 Foundation for Fixed-, Static-Base Tower Cranes	3-55
3.10.2 Out-of-Service Loads on Tower Cranes	3-55
3.10.3 In-Service Loads on Tower Cranes	3-55
3.10.4 Soil Pressure Considerations and Example Problems	3-57
3.10.5 Soil Bearing Capacity Data	3-60
3.10.6 Anchorage of Tower Base	3-61
3.11 CRANE SAFETY AND SELECTION	3-65
4. Rigging Components	4-1
4.1 SLINGS AND HITCHES	4-3
4.1.1 Suspended Load	4-4
4.1.2 Single Vertical Hitch	4-4
4.1.3 Basket Hitch	4-4
4.1.4 Reverse Basket Hitch and Single Length Double Basket Hitch	4-4
4.1.5 Basket Hitch Uses	4-6
4.1.6 Choker Hitch	4-7
4.1.7 Wire Rope Sling Configurations	4-7
4.1.8 Wire Rope Sling Body Construction	4-7
4.1.9 Wire Rope Cores	4-8
4.1.10 Wire Rope Sling Length	4-9
4.1.11 Wire Rope Sling Strength	4-9
4.1.12 Ordering Wire Rope Slings	4-12
4.1.13 Testing Wire Rope Slings	4-13
4.1.14 Chain Slings	4-14
4.1.15 Metal (Wire) Mesh Slings	4-15

4.1.16 Synthetic Webbing Slings	4-16
4.1.17 Fiber (Manila-Nylon-Dacron-Polypropylene) Rope Slings	4-17
4.1.18 Polyester and Kevlar Round Slings	4-17
4.2 ANCILLARY COMPONENTS	4-19
4.2.1 Drums	4-19
4.2.2 Drum Capacity	4-22
4.2.3 Fleet Angle	4-24
4.2.4 Sheaves	4-26
4.2.5 Blocks	4-31
4.2.6 Center Pin	4-34
4.2.7 Selection of a Block	4-36
4.2.8 Inspection of Blocks	4-37
4.2.9 Rigging of a Block	4-37
4.2.10 Mechanical Advantage	4-39
4.2.11 Hooks	4-42
4.2.12 Pins	4-43
4.2.13 Shackles	4-43
4.2.14 Load Attachment Devices	4-45
4.2.15 Eye Bolts and Swivel Eyes	4-45
4.2.16 Design of Lifting Lugs	4-48
4.2.17 AISC Design Parameters for Tension Members	4-49
5. Special Lifting Methods	5-3
5.1 INTRODUCTION	5-3
5.2 JACKING AND CRIBBING	5-3
5.2.1 Detailed Jacking and Cribbing Procedures	5-4
5.3 JACKS — HYDRAULIC CYLINDERS	5-5
5.4 HYDRAULIC PUMPS	5-8
5.5 ROLLERS	5-9
5.6 HYDRAULIC GANTRIES	5-11
5.6.1 Lift Planning with Hydraulic Gantries	5-13
5.7 POLE LIFT SYSTEMS	5-16
5.8 STRAND JACKS	5-20
5.9 OTHER SYSTEMS	5-22
5.9.1 Hoisting Systems	5-22
6. Trailers and Truck Tractors	6-3
6.1 GENERAL	6-3
6.2 TRAILERS	6-3
6.3 TRUCK TRACTORS	6-4
6.3.1 Tractive Effort	6-4
6.3.2 Front and Rear Axle Capacities	6-4
6.3.3 Tire Capacity	6-5

6.4 VEHICLE SPEED	6-5
6.5 TRACTIVE EFFORT	6-6
6.6 NET TRACTIVE EFFORT	6-7
6.7 OVERALL REDUCTION	6-7
6.8 GRADEABILITY	6-8
6.9 GROUND SPEED OF TRACK LAYING VEHICLE	6-9
6.10 ROAD ROLLING RESISTANCE	6-10
6.11 GRADES, SLOPES, AND GRADE RESISTANCE	6-13
6.12 TYPICAL TIRE LOADED RADIUS	6-14
6.13 TYPICAL AXLE RATIOS	6-15
6.14 SAMPLE (UNIT)	6-16
6.14.1 Specifications — Lowbed Tractor	6-16
6.15 SAMPLE (PROJECT)	6-20
6.15.1 Specific Unit Requirements - Tractor, General Purpose	6-20
6.15.2 Specific Unit Requirements - Tractor, Lowbed/Winch	6-21
6.16 SAMPLE TRACTOR AXLE LOADINGS	6-22
6.17 SAMPLE TIRE SERVICE LOAD AND INFLATION TABLES	6-25
7. Transportation	7-1
7.1 HEAVY HAULING AND TRANSPORTATION	7-3
7.1.1 Multi-Axle Hydraulic Platform Trailers	7-3
7.1.2 Self-Propelled, Multi-Axle Hydraulic Transporters	7-8
7.1.3 Low-Bed/Multi-Axle Transporters	7-12
7.1.4 Crawler Transporters	7-14
7.1.5 Schnabel Cars	7-14
7.2 LOAD STABILITY	7-15
7.3 TRANSPORTER CAPACITY REDUCTION DUE TO SPEED	7-18
7.4 PAYLOAD SUPPORT LOCATIONS	7-19
7.5 WHEEL LOAD AND TIRE FOOTPRINT	7-20
8. Barging	8-3
8.1 FLAT DECK BARGE SELECTION REQUIREMENTS	8-3
8.3 DRAFT AND TRIM	8-6
8.4 LIST, TRANSVERSE ANGLE	8-7
8.5 BALLAST REQUIREMENT	8-8
8.7 INTACT STABILITY REQUIREMENT	8-16
8.8 DAMAGED STABILITY REQUIREMENT	8-17
8.9 BARGE MOTION AND FORCES	8-17
8.10 CALCULATION OF FORCES DUE TO ROLL	8-18
8.11 CALCULATION OF FORCES DUE TO PITCH	8-20
8.12 CALCULATION OF FORCES DUE TO HEAVE	8-21
8.13 SEA FASTENING	8-22

8.14	AREA NEEDED FOR SEA FASTENING	8-22
8.15	SEA TRANSPORT DESIGN CONDITION—U.S. COAST TO PUNTO FIJO ...	8-24
8.16	SEA TRANSPORT DESIGN CONDITION VENEZUELA TO PUNTO FIJO ...	8-25
8.17	ROLL-ON AND ROLL-OFF OPERATIONROLL-ON AND ROLL-OFF OPERA- TION CONSIDERATIONS INCLUDE:	8-26
9.	Rigging Plans	9-3
9.1	INTRODUCTION	9-3
9.2	PURPOSES OF STUDIES	9-3
9.3	PRELIMINARY STUDIES	9-4
9.3.1	Timing	9-4
9.3.2	Aims of Preliminary Studies	9-4
9.3.3	Scope of HL/HH Activities	9-4
9.3.4	Drafting of the Technical Specification	9-5
9.3.5	Information Gathering	9-6
9.3.6	Data Requirement Sheets	9-9
9.3.7	Equipment and Method Selection	9-13
9.3.8	General Considerations in Preliminary HL/HH Plans	9-23
9.3.9	Outcome	9-25
9.3.10	Constructability Studies and Pre-Engineering	9-25
9.3.11	Development	9-25
9.4	DEVELOPED STUDIES	9-26
9.4.1	Categories of Drawings	9-26
9.4.2	Information To Be Contained on Drawings	9-27
9.4.3	Preparation of Detailed Drawings	9-31
9.4.3.1	Views Required	9-31
9.4.3.2	Refinement of Lift Equipment Selection	9-32
9.4.3.3	Below-the-Hook Rigging Requirements	9-32
9.4.3.4	Lifting Attachments	9-33
9.4.3.5	Tailing	9-34
9.4.3.6	Ground Preparation	9-34
9.4.3.7	Receipt of the Load	9-34
9.4.3.8	Operational Procedures	9-34
9.5	FINAL RIGGING PLANS	9-35
9.5.1	Contents of Final Rigging Plans	9-35
9.5.2	Lift Data Sheets	9-36
9.5.2.1	Lifted Piece Description and Reference Drawing	9-36
9.5.2.2	Crane Configuration	9-36
9.5.2.3	Crane's Fixed Weight	9-36
9.5.2.4	Piece Weight	9-36
9.5.2.5	Total Weight To Be Lifted	9-37
9.5.2.6	Pick Capacity	9-37

9.5.2.7 Set Capacity	9-37
9.5.2.8 Clearances	9-37
9.5.2.9 Two Crane Lifts	9-37
9.5.3 Method Statement Policy	9-37
9.5.4 Project Lift Manual	9-38
9.6 EXAMPLES OF TYPICAL RIGGING DRAWINGS	9-39
10. Glossary	10-3
11. References	11-3
Index.....	12-3

1

RIGGING PROCEDURES AND SAFETY



1. Rigging Procedures and Safety

1.1 RIGGING PROCEDURES

1.1.1 General

Rigging is one of the most important safety and risk exposure considerations on any construction project and Bechtel's corporate procedures reflect that importance.

Bechtel corporate procedures require that each construction project develop a rigging control plan appropriate for the project. This plan must address specific customer requirements, local safety regulations and Bechtel Construction Operations Incorporated operating instructions. The construction site must also provide for:

- Operator and rigging training
- Periodic and frequent inspection of tools and equipment
- Preplanning of rigging operations
- Monitoring of rigging work operations

1.1.2 Corporate References

The following Bechtel Corporate References define basic responsibilities for development, planning and execution for heavy and critical lift activities.

SITE MANAGERS MANUAL, INSTRUCTION S4.6, RIGGING WORK OPERATIONS

FIELD ENGINEERING MANUAL, INSTRUCTION F4.3, CONSTRUCTION RIGGING PLANS

BCOI OPERATING INSTRUCTION 4MP - T11 - L101 DEFINES THE CRITERIA FOR THE USE OF BEO RIGGING SERVICES ON BECHTEL CONSTRUCTION PROJECTS

THE FOLLOWING BECHTEL STANDARD WORK PROCESS PROCEDURES (SWPPs) RELATE TO RIGGING ACTIVITIES:

4MP - T81 - 01901— CRANE OPERATOR QUALIFICATIONS

4MP - T81 - 01902— COMPETENT PERSON RIGGER QUALIFICATIONS

4MP - T81 - 01903— CONSTRUCTION RIGGING WORK OPERATIONS

4MP - T81 - 01904— CRANES USE AND OPERATION

4MP - T81 - 01905— CRANE LOAD TEST PROCEDURE

1.1.3 Definitions

Certified Rigging Engineer—A Certified Rigging Engineer is an individual certified by BEO as satisfying Bechtel's education, knowledge and expertise requirements, qualifying him/her to review and approve heavy/critical lift plans and heavy haul plans.

BEO Qualification Program Coordinator (QPC)—The individual designated by Bechtel Equipment Operations Incorporated (BEO) responsible for coordinating all activities pertaining to the certification of Qualified Crane Operator Examiners and Competent Person Rigger Trainer / Examiners. The QPC is to be an individual with an extensive background in the use and operation of cranes and lifting equipment and in-depth knowledge of crane inspection, safety and maintenance.

Competent Person Rigger Trainer (CPRT)—An individual verified by the BEO Qualification Program Co-ordinator (QPC) as meeting Bechtel's requirements (as defined in SWPP-01902) for experience, education, background and/or training to qualify him/her as a Competent Person Rigger Trainer. He/she also tests and qualifies CPRs.

Competent Person Rigger (CPR)—An individual verified by the Competent Person Rigger Trainer (CPRT) as meeting Bechtel's requirements (as defined in SWPP-01902) for experience, education, background and/or training to qualify him/her as a Competent Person Rigger.

Qualified Crane Operator Examiner—A subject expert qualified by BEO to (1) administer practical, equipment-specific tests and (2) qualify crane operator candidates at the job site. The Qualified Crane Operator Examiner must have extensive knowledge of mechanical, hydraulic, and truck cranes, applicable jurisdictional codes, standards & regulations (e.g. ANSI/OSHA within the U.S.A.), and Bechtel safety philosophy and procedures.

Crane Operator—Any project or subcontractor employee qualified to operate a crane as specified in SWPP 4MP-T81-01901, Crane Operator Qualification.

Project Rigging Engineer—An individual meeting the requirements of SWPP-01903, appointed by a PFE to prepare rigging plans and calculations under the direction of the PFE and the Rigging Supervisor.

Rigging Supervisor—An individual with demonstrated technical skills, assigned responsibility for developing work methods and plans, planning and supervising the performance of rigging / hauling operations on a project.

Lift personnel—Craft employees whose job duties and responsibilities include involvement in lifting / moving activities.

Ton—Unless noted otherwise, the word “ton” as used herein, refers to a US ton of 2000 lbs.

Where noted, an imperial ton is 2240 lbs.

A metric ton, (Te or tonne) refers to a mass of 1000kg. (1000kg is equivalent to 2205 lbs).

Note: For the Definitions of “lifts” that follow, the Rigging Supervisor or Rigging Engineer may categorize any lift, they deem necessary, to the more onerous standard. This may be due to lift complexities, operational considerations, environmental factors, or administrative considerations.

Rigging Plans—Rigging plans are the documents containing all the pertinent information and procedures necessary to define how a lift/haul is to be conducted safely.

Lifting device—A machine used to raise or lower a load such devices including cranes, hoists, chain falls, jacks, jacking systems, strand lift system, gin poles, derricks, monorail hoist, gantry crane; but excluding such devices as elevators & conveyors.

Lifting—The process of lifting, or positioning equipment, components, or materials with a Lifting Device.

Rigging equipment / lifting gear—The hardware or equipment used to attach a load to a lifting device; not in itself capable of providing any movement to lift or lower.

Rigging—The process of safely attaching a load to a lifting device.

Hauling—The process of transporting heavy equipment, components, or materials using a wheeled transporter / trailer either towed by a prime mover or self-driven. Skidding systems, rollers, and similar devices are considered to be included.

Heavy Haul and Oversize Cargo—Out-of-gauge or overweight cargo as defined in SWPP-01903.

Specialized Carriers and Rigging Association (SC&RA) - An international association serving members engaged in the crane, rigging and oversize/overweight transportation industries.

Crane—For the purposes of SWPP-01903 defining Crane Operator Qualifications, a crane is any Lifting Device rated over 3 tons in one of the following categories:

General use Cranes (to 350 tons capacity) including but not limited to:

- Hydraulic truck-mounted cranes, including Rough Terrain and All Terrain Cranes & Boom Trucks
- Friction and hydraulic drive Lattice Boom Truck-mounted Cranes
- Friction and hydraulic drive Lattice Boom Crawler Cranes

Heavy lift cranes and specialized cranes including:

- Ringer Cranes (over 350 tons)
- Heavy crawler cranes (over 350 tons)
- Heavy Mobile truck cranes (over 350 tons)
- Cranes using Superlift or other similar capacity enhancing devices
- Custom cranes (such as Lampson TransiLift, Mammoet MSG, Van Seumeren PTC)
- Derricks (stiff-leg and guyed)
- Cranes having uncommon operating features

Alternative heavy lifting systems including:

- Gin Poles
- Strand jack systems (used with or without towers)
- Jacking mast systems (push up or climbing type)
- Lattice lifting gantries (fixed or mobile)

Mobile gantries including:

- Telescoping hydraulic lifting gantries (mobile or fixed)

Lift Categories

- Light Lift
Any lift where the payload weight is 10 tons or less.
- Medium Lift
Any lift where the payload weight is over 10 tons but less than 50 tons.
- Heavy Lift
Any lift where the payload weight is 50 tons or greater.
- Critical Lift

Any lift that exceeds 90 percent of crane's chart capacity; any Multiple-crane lift where either crane exceeds 75% of the cranes load capacity; requires one (or both) of the cranes to change locations during the lifting operation; any up ending-down ending operation during the lift; or any lift over operating or occupied facilities, process pipe racks, or near power lines. Any lift involving a complex rigging arrangement or that requires specialty rigging should also receive this classification. All lifts with Hydraulic Gantries shall be deemed critical and a rigging plan shall be developed for these lifts. Project management may classify any lift that involves sensitive or risk to costly equipment as critical.

Qualification—The process of verifying that a crane operator has the requisite experience, education and/or training and meets any other special requirements necessary for satisfactory job performance.

Payload Weight—The weight of the item to be lifted or hauled. Payload weight includes the actual item weight, plus the weight of attachments, saddles, temporary supports, etc. Payload weight does not include rigging weight.

Working Load limit (WLL)—The working load limit is the maximum load that an item of lifting equipment is designed to raise, lower or suspend.

Safe Working Load (SWL)—In most cases, the Safe Working Load will be the same as the WLL. The exceptions are where the particular conditions of use require a reduction to a lower safe working load. Examples would be severe environmental conditions such as very low temperatures, inaccuracy of weight, likelihood of shock loading

Proof or test load—A proof or test load is the load applied to a Lifting Device or Rigging Equipment for the purpose of proof testing. It should appear on the test certificate.

Thorough examination—A periodic visual examination supplemented by such other means of measurement and testing as may be required to check whether the equipment is safe to use.

Factor of Safety (FOS)—The Factor of Safety is the ratio between minimum breaking load and safe working load.

Bechtel Rigging Department — Bechtel Rigging Department is a centralized rigging core group in Bechtel functioning under Bechtel Equipment Operation.

1.1.4 Responsibilities

Site Manager - The site manager has the ultimate responsibility for ensuring that all rigging on the construction site follows the rigging requirements of the Section 1.1.5.

Project Field Engineer (PFE) - The project field engineer is responsible to review and approve the light and medium rigging lifts and transportation activities. Also, he is responsible to coordinate and obtain approval from Bechtel Certified Rigging Engineer for critical, heavy lift and heavy haul activities.

Bechtel Certified Rigging Engineer - The certified Rigging Engineer is responsible for approval of all critical, heavy haul and heavy lift rigging plans prepared by either the rigging engineer or heavy haul/heavy lift subcontractor.

Rigging Engineer - The rigging engineer is responsible for planning of all medium, critical, heavy haul and heavy lift work operations, including the preparation of drawings and calculations. This individual works under the direction of the PFE and in conjunction with the Rigging Supervisor and Certified Rigging Engineer.

Rigging Supervisor (or Superintendent) - The Rigging Supervisor is responsible for determining work methods and plans for rigging operations and safe execution of the rigging activities. The Rigging Superintendent works in conjunction with the Rigging Engineer in preparation of the required lift plans and ensures that the required equipment, materials and qualified craft personnel are available for the execution of the rigging work.

Bechtel Rigging Department- Bechtel Rigging Department is responsible to provide Rigging Engineering, Heavy Haul and Heavy Lift service to all Bechtel- Becon projects worldwide. These services include:

Engineering: Preparation of rigging plans and related calculations
Design Heavy Haul & Heavy Lift equipment support system
Equipment studies, selection and conceptual rigging plans. Support project on preparation of the technical section of the bid documents. Review and approve rigging plans prepared by the subcontractors or field Barge roll on-roll off, dock jetty design loading, sea fastening of loads on barge.

Field Execution: Execute rigging operation at the job site. Witness and approve critical lifts, Heavy Lift and Heavy Hauls.
Subcontract field management.

Other Services: Rigging Workshop and Training

1.1.5 Requirements

Each rigging operation, regardless of size, should be planned to ensure a safe lift. Due to the added exposure and complexity of heavier lifts, the planning requirements for heavier lifts are more comprehensive. The minimum requirements for lifts and lift planning are outlined below.

Light Lifts - Light rigging lifts should be accomplished using good, safe rigging practices under the direction of the responsible Rigging Supervisor.

Medium Lifts - A rigging plan must be approved by the Project Field Engineer (PFE) prior to performing medium rigging lifts.

Critical, Heavy Lifts and Heavy Haul - A rigging plan must be prepared either by the Rigging Engineer or Heavy Haul/Heavy Lift Subcontractor and must be reviewed and approved by the Bechtel Rigging Department.

Independent Review - On some projects third party review of Critical, Heavy Lifts and Heavy Hauls may be required. Reviewer must be Bechtel Certified Rigging Engineer.

Rigging plans - Rigging plans are typically prepared by either the Rigging Supervisor or the Rigging Engineer and are intended to reflect all important aspects of the construction rigging work operation. The plans are utilized both for preplanning the lift with the Rigging Supervisor

and Rigging Engineer and for pre-lift briefings with the construction crews performing the work. See section 8 of this manual for a complete discussion of Rigging plans. Rigging plans must address or include the following minimum elements:

A layout of the work area including the locations of all obstacles and interferences.

Minimum clearances and clearance requirements from existing facilities and utilities.

Definition of the component to be lifted including the verified weight of the item and the authorized attachment or lift points.

Locations of underground utilities that could affect the rigging work operation and that require special clearances or cribbing to perform the work.

Rigging equipment to be used for the rigging operation including cranes, wire rope slings, spreader beams, shackles, hooks and other components in the load chain.

Any special precautions that the construction work crew should be aware of prior to making the lift, (e.g., removal of temporary shipping skids prior to rigging).

Rigging Calculations - Calculations performed in support of rigging work operations shall identify any special requirements for the lift, the type of equipment and hardware to be used, and the sequence of the rigging operation. Calculations may be performed by any Field Engineer, but must be checked and accepted by the Rigging Engineer prior to application.

1.2 RIGGING SAFETY

1.2.1 General

Bechtel is committed to a **ZERO ACCIDENT** safety philosophy. The movement of heavy equipment and materials can result in serious accidents and injury if not properly planned and executed. Performing rigging work operations safely is one of the cornerstones of Bechtel's important element in the overall safety program. Construction crew trainees are typically provided with a Riggers Handbook or a Rigging Card to reinforce the training efforts. These handbooks and cards summarize basic safe rigging practices and provide sling tables and shackle charts. Hard-hat stickers listing sling capacities have also been used to provide similar information.

1.2.2 Occupational Safety and Health Administration (OSHA) Safety Regulations

Requirements for safe construction rigging work practices in the United States are defined in the Code of Federal Regulations Title 29 Part 1926, Safety and Health Regulations for

Construction. This document is organized into various “subparts” that each address a particular aspect of construction work operations. The subparts applicable to rigging work operations are discussed below.

Subpart E - Personal Protective and Life Saving Equipment

This subpart establishes minimum requirements for the use of fall protection devices including safety belts, lifelines, lanyards and safety nets. The execution of rigging work operations often require individuals to work in elevated locations subject to falls. The requirements of this subpart are designed to prevent serious injuries that could result from a fall.

Subpart G - Signs, Signals, and Barricades

This subpart establishes minimum requirements for signaling and controlling traffic flows. Since rigging work operations often involve the movement of equipment and materials on roadways, this subpart defines the minimum signaling and barricading requirements.

Subpart H - Materials Handling, Storage, Use, and Disposal

This subpart provides minimum requirements for the use of material handling equipment including rope, slings, chains, shackles, and hooks. Since the requirements of this subpart are very specific, it is important that the rigging engineer or specialist have a comprehensive knowledge of Subpart H.

Subpart I - Tools - Hand and Power

This subpart defines requirements for the handling and use of lever, ratchet, screw, and hydraulic jacks. Since jacks are used extensively in rigging operations, the requirements of this subpart are directly applicable to the rigging activities.

Subpart N - Cranes, Derricks, Hoists, Elevators, and Conveyors

This subpart provides specific requirements for the control of heavy lift rigging equipment at the construction site. The subpart addresses requirements for rigging hand signals, rigging equipment and hardware inspections, posting of crane load charts, and rigging work execution.

This subpart also provides detailed requirements for the design, testing, and use of crane or derrick suspended personnel platforms which are discussed in more detail in Section 25 of this handbook. Helicopter operations requirements, and use of base-mounted drum and overhead hoists are also covered.

Subpart O - Motor Vehicles, Mechanized Equipment, and Marine Operations

This subpart addresses the use of motorized equipment including rubber tired and crawler rigging equipment at the work site. Specifically, the subpart includes requirements for identifying equipment locations at night and for control of work suspended overhead.

Subpart R - Steel Erection

This subpart defines requirements for steel erection which apply to rigging work operations that require the erection of steel rigging structures at the site.

Subpart T - Demolition

This subpart defines safety regulations for the demolition of buildings and materials. Since many rigging operations involve demolition activities, these regulations would be directly applicable.

Subpart U - Blasting and Use of Explosives

This subpart addresses safety control measures that must be implemented in the immediate vicinity of blasting operations and imposes limitations on the use of two-way radios. Since many rigging operations employ the use of radios, it is important to understand the requirements of this subpart when there are blasting operations on or near the site.

Subpart V - Power Transmission and Distribution

This subpart defines minimum safe clearance requirements between cranes and crane booms and energized electrical power lines. In the development of rigging plans, this minimum safe clearance requirement often determines how the rigging work operation can be performed. A thorough understanding of the requirements of this subpart is essential to effectively plan and execute rigging work operations.

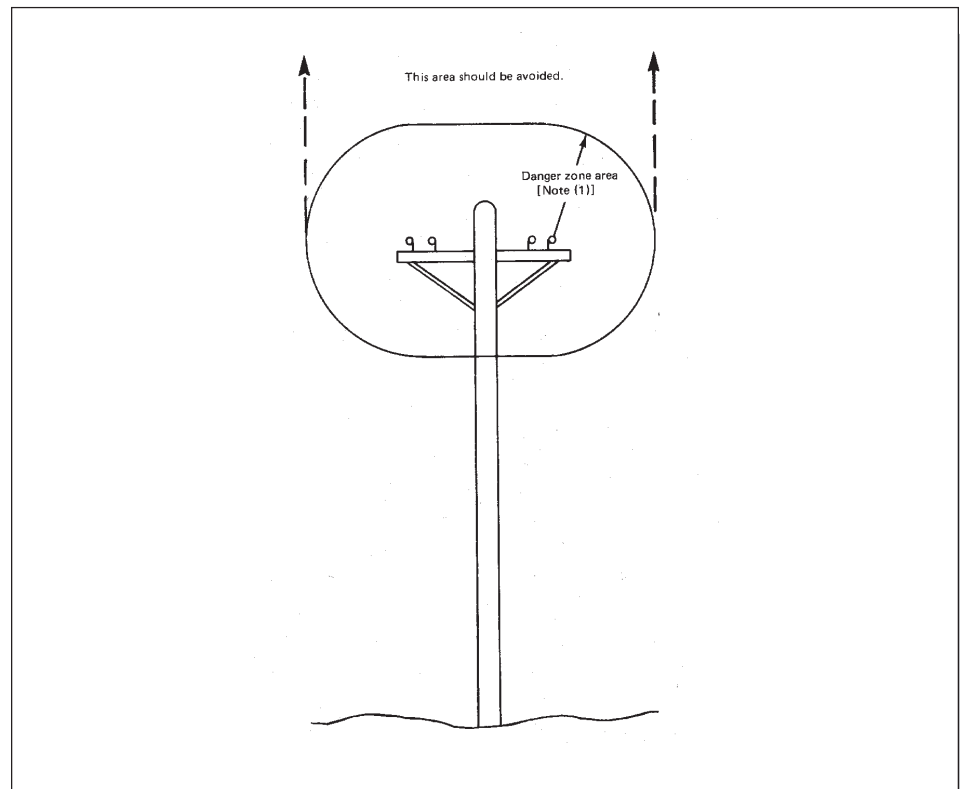

Figure 1.2-1 Danger Zone for Cranes and Lifted Loads Operating Near Electrical Transmission Lines

The figure above defines the danger zone for operations near electrical transmission lines. Minimum radial danger zone distances are shown in the table on the next page.

TABLE 1.2-1 REQUIRED CLEARANCE FOR NORMAL VOLTAGE IN OPERATION NEAR HIGH VOLTAGE POWER LINES AND OPERATION IN TRANSIT WITH NO LOAD AND BOOM OR MAST LOWERED

Normal Voltage, Kv (Phase to Phase)		Minimum Required Clearance, feet (meters)
Operation Near High Voltage Power Lines		
	to 50	10 (3.05)
Over 50	to 200	15 (4.60)
Over 200	to 350	20 (6.10)
Over 350	to 500	25 (7.62)
Over 500	to 750	35 (10.67)
Over 750	to 1000	45 (13.72)
Operation in Transit With No Load and Boom or Mast Lowered		
	to 0.75	4 (1.22)
Over 0.75	to 50	6 (1.83)
Over 50	to 345	10 (3.05)
Over 345	to 750	16 (4.87)
Over 750	to 1000	20 (6.10)

1.3 AMERICAN NATIONAL STANDARD INSTITUTE (ANSI) SAFETY CODES

ANSI standards provide comprehensive guidance on the variety of equipment and work operation requirements directly applicable to rigging activities. Many of these standards are invoked by OSHA and other safety regulations. The following is a summary of the applicable requirements.

ANSI B30.1, Jacks

This standard addresses safety requirements for the construction, installation, operation, inspection, and maintenance of ratchet, screw, lever, and hydraulic jacks. Minimum inspection requirements are included before jacks are to be used.

ANSI B30.2.0, Overhead and Gantry Cranes**ANSI B30.3, Hammerhead Tower Cranes****ANSI B30.4, Portal, Tower, and Pillar Cranes****ANSI B30.6, Derricks****ANSI B30.8, Floating Cranes and Floating Derricks****ANSI B30.11, Monorail Systems and Underhung Cranes****ANSI B30.13, Controlled Mechanical Storage Cranes****ANSI B30.14, Side Boom Tractors****ANSI B30.17, Overhead and Gantry Cranes (Top Running Bridge, Single Girder, Underhung Hoist)****ANSI B30.18, Stacker Cranes****ANSI B30.22, Articulating Boom Cranes****ANSI B30.24, Container Cranes****ANSI B30.25, Material Handling Hybrid Cranes**

These standards establish safety requirements for various types of cranes. The standards provide specific frequent and periodic inspection requirements, operator qualifications, and standard hand signals. It is important to utilize the right standard for the right type of crane.

ANSI B30.5, Crawler, Locomotive, and Truck Cranes

This standard provides detailed requirements for the use, inspection, testing, and refurbishment of mobile cranes commonly used on construction sites. The standard defines specific requirements for frequent (daily to monthly) and periodic (one to twelve month intervals) crane and crane hardware inspections. Knowledge of the requirements of this standard is very important for personnel actively involved in construction rigging work operations.

ANSI B30.7, Base Mounted Drum Hoists**ANSI B30.16, Overhead Hoists (Underhung)****ANSI B30.21, Manually Lever Operated Hoists**

These standards provide detailed requirements for hoists that are frequently used in construction rigging work operations.

ANSI B30.9, Slings

This standard provides a comprehensive set of safety standards for the use and periodic inspection of alloy steel chain, wire rope, metal mesh, natural and synthetic fiber rope, and synthetic webbing (nylon, polyester, and polypropylene). The Rigging Engineer and Rigging Specialist must have a good working knowledge of this standard to effectively design and use slings in construction work operations.

ANSI B30.10, Hooks

This standard provides detailed requirements for all types of hooks.

ANSI B30.12, Handling Loads from Suspended Rotorcraft (Helicopters)

This standard provides specialized requirements for handling loads with helicopters. Since this form of material handling is becoming more common, a basic understanding of the

requirements of this standard is beneficial.

ANSI B30.19, Cableways

This standard establishes requirements for the special application of cableways used in lifting and material handling activities.

ANSI B30.20, Below-the-Hook Lifting Devices

This standard establishes requirements for lifting devices such as lifting beams (spreader beams), edge grip sheet clamps, and plate clamps. The requirements for the design, fabrication, inspection, and use of lifting beams is directly applicable to construction rigging work operations.

ANSI B30.23, Personnel Lifting

This standards establishes requirements for personnel lifting and hoisting.

ANSI B56.1, Lift and High Lift Trucks (Forklifts)

ANSI B56.5, Guided Industrial Vehicles

ANSI B56.6, Rough Terrain Forklift Trucks

ANSI B56.7, Industrial Crane Trucks

ANSI B56.8, Personnel and Burden Carriers

ANSI B56.9, Operator Controlled Industrial Tow Tractors

These standards establish requirements for many forms of equipment commonly used in construction rigging operations.

ANSI N45.2.15, Hoisting, Rigging, and Transporting of Items at Nuclear Power Plants

This is a specialized standard applicable to rigging operations at nuclear power stations.

1.3.1 Responsibilities

The lists below provide sample safety responsibilities of Site Supervision and Crane Operators.

Specialized Carriers and Rigging Association (SC&RA) Crane Operator Certification

Mobile Crane Drafting Task Force Responsibilities of Site Supervision and General Management

The question of responsibility for the various aspects of a crane operation often remains unclear until a serious accident occurs and a court of law is forced to decide where the responsibility lies. Because crane operations are complex and differ from one job to the next, it is unlikely that a single set of guidelines can cover all the parameters involved. However, the following list of Site Supervision and General Management responsibilities can be applied to most situations.

Site supervision is responsible to:

1. Provide a well-prepared working area for the crane before it arrives on the job. This will require:
 - a. Identifying and evaluating site access and usability.
 - b. Assuring there is room to erect and/or extend the boom.

- c. Preparing for blocking to be made available to support the boom while it is being assembled and dismantled.
 - d. Oversee that operating locations are graded, level and compacted.
 - e. Preparing for blocking to be made available for outrigger support.
 - f. Assessing the suitability of supporting surface to handle expected loads.
 - g. Assuring that hardwood mats or cribbing are available if the ground is very soft. (Informing the crane owner that the ground is soft.)
2. Determine the correct load weight and radius and inform the operator. (Site supervision should know the maximum radius, load weight, and lift height of each “pick” before ordering the crane.)
 3. Ensure the crane is appropriate for the task to be completed.
 4. Ensure the operator is well trained, experienced and competent to operate the assigned crane on the particular job involved.
 5. Ensure the operator knows the load chart and is capable of determining the crane’s net capacity for all possible operating configurations.
 6. Ensure the operator is knowledgeable, capable, and aware of the assigned responsibilities.
 7. Supervise all work involving the crane.
 8. Ensure that a thorough crane maintenance and inspection program is established and maintained. This will involve developing crane log books that facilitate the reporting of all work needed and completed on the crane.
 9. Know which local, state and federal rules and regulations would affect safe operation of the crane.
 10. Locate and identify site hazards and restrictions such as electric power lines and piping.
 11. Restrict access to a work area by unauthorized personnel.
 12. Review planned operations to include determination of working height, boom length, load radius and weight.
 13. Determine if there is adequate room for extension of crawlers, outriggers, and counterweights.
 14. Determine who is the signal person.
 15. Ensure that signal persons are competent and capable of directing the crane and load to ensure the safety and efficiency of the operation.
 16. Know how to communicate at the site with operator, crew, and signal person.

17. Be familiar with the preparation of the crane for loading or unloading on trailers; and be familiar with the differences between rail and barge loading.
18. Know loading procedures.
19. Ensure the loads are properly rigged.
20. Implement a basic maintenance inspection and record keeping program.
21. Know the “Responsibilities of the Crane Operator” and, understand the “Responsibilities of Site Supervision and General Management.”
22. Be familiar with the unique differences in operations when working under these specific conditions:
 - a. Multi-crane lifts
 - b. Suspended personnel platforms
 - c. Clamshell \ Dragline operations
 - d. Pile driving and pulling sheeting
 - e. Concrete operations
 - f. Demolition operations
 - g. Barge operations
 - h. Magnet operations
23. Understand how to verify weight and center of gravity of the load.
24. Provide ongoing, high quality training and upgrading programs for all personnel.
25. Understand requirements for protective measures against electrical hazards.
 - a. Grounding
 - b. Proximity warning devices
 - c. Insulated links
 - d. Boom cages
 - e. Proximity to electric power lines, radio, and microwave structures.
26. Be familiar with load share and load transfer in multi-crane lifts.

**SC&RA Crane Operator Certification Mobile Crane Drafting Task Force
Responsibilities of the Crane Operator**

The question of responsibility for the various aspects of a crane operation is too often unclear until a serious accident occurs and a court of law decides where the responsibility lies

Because crane operations are complex and differ from one job to the next, it is unlikely a single set of guidelines can cover all the parameters involved. However, the following list of Crane Operator responsibilities can be applied to most situations.



The operator is responsible to:



1. Be in condition physically, mentally, and emotionally to have full control of the machine.
2. Know the machine well. The operator must understand the functions and limitations of the machine as well as its particular operating characteristics.
3. Be familiar with the content of the crane operating manual.
4. Be totally familiar with the crane load chart. The operator must understand the correct meaning of all notes and warnings, and be able to calculate or determine the actual net capacity of the crane for every possible configuration.
5. Inspect and perform routine maintenance on the crane regularly, as prescribed by the both the owner and manufacturer.
6. Inform supervision and/or the owner of any problems, needed maintenance, or necessary repairs to the machine. This should be done in writing, preferably in the machine log book.
7. Record the available details of inspections, maintenance, and work done on the crane while in the field.
8. Supervise and train the oiler and/or apprentice in their duties.
9. Be aware of any site condition that could affect the crane operation and check that the site is adequately prepared for the crane.
10. Be aware of the presence of power lines and/or other electrical hazards and refuse to operate the crane if the crane boom, hoist rope, or load will come closer to a power line than the absolute limit of approach specified in ASME B30.5.
11. Review the planned operation and requirements with site supervision.
12. Know how to identify the load and rigging weight, how to determine where the load is to be placed and how to verify the exact radius. Normally the operator is not responsible for determining the weight of the load. However, if the operator does so, or lifts the load without verifying the weight with site supervision, the operator becomes totally responsible for the lift and any consequences that result.
13. Determine the number of parts of hoist line required.
14. Check the load chart to ensure the crane has sufficient net capacity for the lift.
15. Select (from manufacturer information) the appropriate boom, jib, and crane configuration to suit the load, site and lift conditions.
16. Be knowledgeable of how to assemble, set up, and rig the crane properly.

17. Consider all factors that might reduce crane capacity and inform management of the need to make appropriate adjustments.
18. Know basic load rigging procedures and ensure they are applied (possible only when the load is visible to the operator).
19. Communicate with the designated signal person.
20. Direct the oiler and/or apprentice to a safe place during operation.
21. Operate the crane in a smooth, controlled and safe manner.
22. Know how to move the crane safely under its own power.
23. Shut down and securing the machine properly when it is to be unattended.
24. Stay current in the skills and knowledge necessary to safely operate the crane.

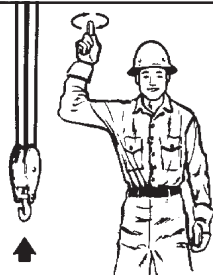
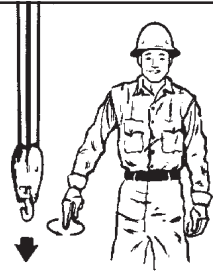
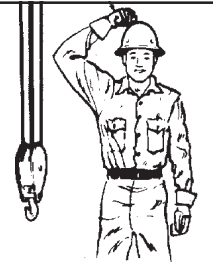
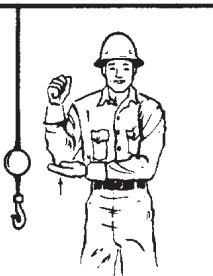
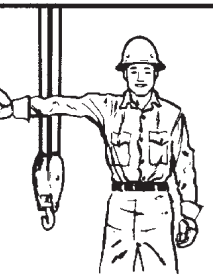
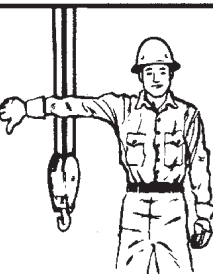
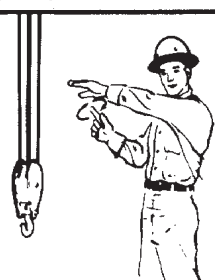
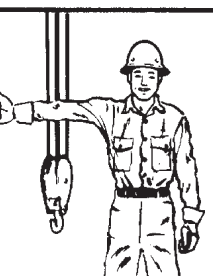
1.3.2 Hand Signals

The figures below provide samples of typical hand signals for controlling crane operations.

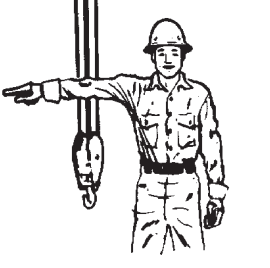
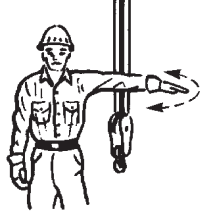
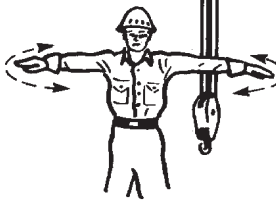
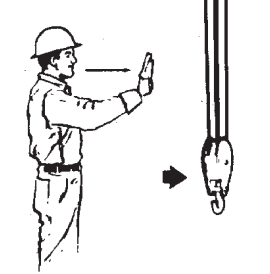
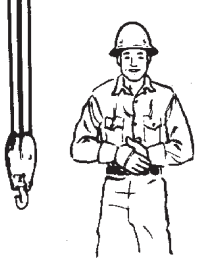
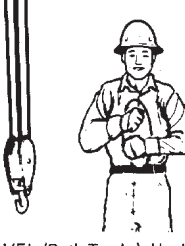
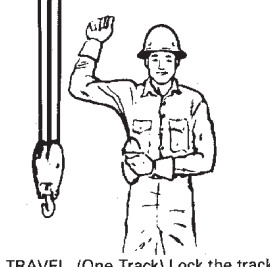
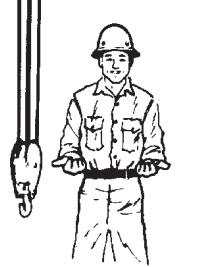
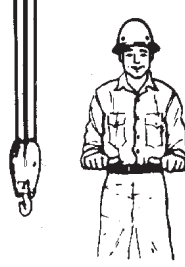
 <p>HOIST. With forearm vertical, forefinger pointing up, move hand in small horizontal circle.</p>	 <p>LOWER. With arm extended downward, forefinger pointing down, move hand in small horizontal circle.</p>	 <p>USE MAIN HOIST. Tap fist on head; then use regular signals.</p>
 <p>USE WHIPLINE (Auxiliary Hoist). Tap elbow with one hand; then use regular signals.</p>	 <p>RAISE BOOM. Arm extended, fingers closed, thumb pointing upward.</p>	 <p>LOWER BOOM. Arm extended, fingers closed, thumb pointing downward.</p>
 <p>MOVE SLOWLY. Use one hand to give any motion signal and place other hand motionless in front of hand giving the motion signal. (Hoist slowly shown as example.)</p>	 <p>RAISE THE BOOM AND LOWER THE LOAD. With arm extended, thumb pointing up, flex fingers in and out as long as load movement is desired.</p>	 <p>LOWER THE BOOM AND RAISE THE LOAD. With arm extended, thumb pointing down, flex fingers in and out as long as load movement is desired.</p>

 <p>SWING. Arm extended, point with finger in direction of swing of boom.</p>	 <p>STOP. Arm extended, palm down, move arm back and forth horizontally.</p>	 <p>EMERGENCY STOP. Both arms extended, palms down, move arms back and forth horizontally.</p>
 <p>TRAVEL. Arm extended forward, hand open and slightly raised, make pushing motion in direction of travel.</p>	 <p>DOG EVERYTHING. Clasp hands in front of body.</p>	 <p>TRAVEL (Both Tracks). Use both fists in front of body, making a circular motion about each other, indicating direction of travel, forward or backward. (For land cranes only.)</p>
 <p>TRAVEL (One Track) Lock the track on side indicated by raised fist. Travel opposite track in direction indicated by circular motion of other fist, rotated vertically in front of body. (For land cranes only.)</p>	 <p>EXTEND BOOM (Telescoping Booms). Both fists in front of body with thumbs pointing outward.</p>	 <p>RETRACT BOOM (Telescoping Booms). Both fists in front of body with thumbs pointing toward each other.</p>
 <p>EXTEND BOOM (Telescoping Boom). One Hand Signal. One fist in front of chest with thumb tapping chest.</p>	 <p>RETRACT BOOM (Telescoping Boom). One Hand Signal. One fist in front of chest, thumb pointing outward and heel of fist tapping chest.</p>	

2

BASIC ENGINEERING PRINCIPLES



2. Basic Engineering Principles

2.0 INTRODUCTION

For any rigging operation, the first order of business is to determine forces (loads) and their direction, magnitude, load-bearing surfaces, method of connection, required support, effects of motion, etc. After these factors are determined, equipment selection will follow for safe handling and installation of the load.

To determine the above factors, the rigger must know something about fundamental engineering principles such as determination of stresses, effect of motion, weight of loads, center of gravity, and factor of safety.

2.1 TRIGONOMETRIC FUNCTIONS

Trigonometry is the backbone of all engineering and is no exception for rigging engineering. Trigonometry is used to calculate several things such as the forces that a sling will see when used at an angle or the load distribution when a load is lifted out of level. Table 2.1-1 shows several formulas commonly used in engineering.

Table 2.1-1 Trigonometric Solutions for Right Angle		
Given	Required	Formulas
a, c	A, B, b	$\sin A = a/c$ $\cos B = a/c$ $b = (c^2 - a^2)^{1/2}$
a, b	A, B, & c	$\tan A = a/b$ $\tan B = b/a$ $c = (a^2 + b^2)^{1/2}$
A, a	B, a, c	$B = 90 - A$ $b = a \cot A$ $c = a/\sin A$
A, b	B, a, c	$B = 90 - A$ $a = b \tan A$ $c = b/\cos A$
A, c	B, a, b	$B = 90 - A = c \sin A$ $b = c \cos A$

2.2 CENTER OF GRAVITY

Jobsite accidents are caused by the lack of understanding that whenever a load is lifted, the center of gravity of the load will place itself vertically below the hook, regardless of the arrangement of the slings, lift beams, or other attachments. The reason is based on the fact that the sum of the forces and moments needs to be zero for a body in equilibrium.

The center of gravity of a body is that point on the body through which the weight of the body could be considered to be concentrated for all orientations of the body. For a body whose weight per net volume is uniform, the center of gravity lies at its centroid. The center of gravity is the location where the center of the object's entire weight is theoretically concentrated and where the object will balance when it is lifted. For a balanced lift, the object's center of gravity is always in line below the hook. The manufacturers normally provide the center of gravity locations of equipment, reactors, heat exchangers, and vessels. However, manufacturers' drawings typically have more information than just the center of gravity location, and the engineer needs to sift through all of the information and identify what is relevant. In some cases, unfortunately, there is not enough information. When this occurs, conservative assumptions will need to be made to proceed with the study at hand. The engineer is responsible for contacting the appropriate people and validating the assumptions. After the center of gravity is determined, the loads that each lifting point receives can be determined. Two basic methods are used for determining this: the sum of the moments or taking proportions.

For these exercises assume that objects are being lifted by two cranes, load lines are plumb, and object will remain level during lifting.

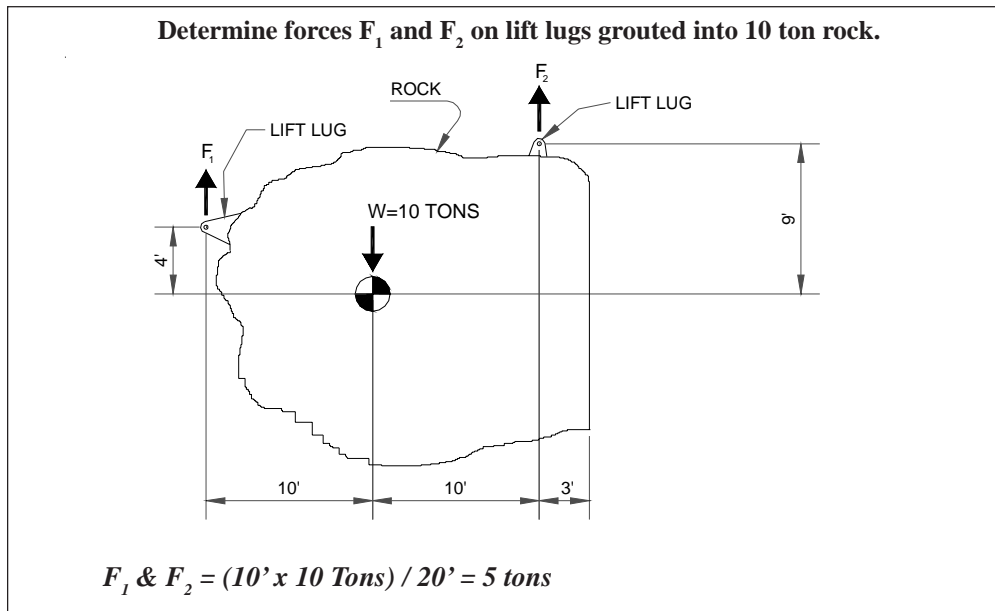

Determine vertical lifting forces P_1 and P_2 on lift lugs for heat exchanger:
Weight = 80,000 kg.

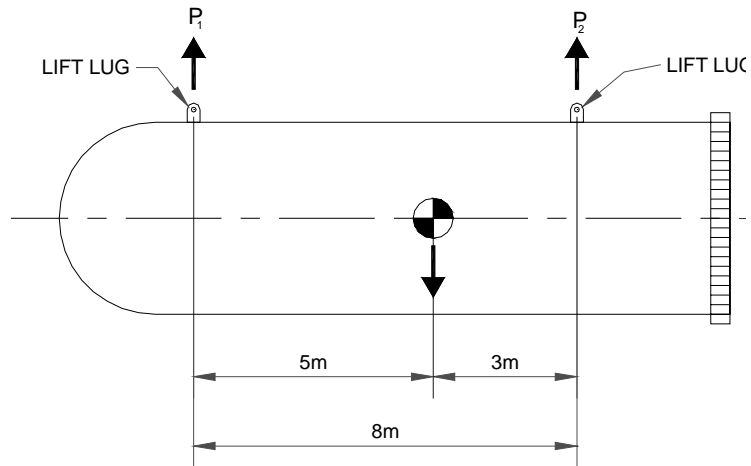

$$P_1 = (3m \times 80,000 \text{ kg}) / 8m = 30,000 \text{ kg}$$

$$P_2 = (5m \times 80,000 \text{ kg}) / 8m = 50,000 \text{ kg}$$

Determine forces R_1 and R_2 for 1100 ton splitter column at beginning of upending operation.

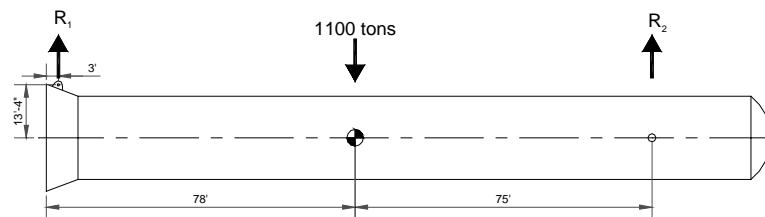

$$R_1 = (75' \times 1100 \text{ tons}) / (75' + 78' - 3') = 550 \text{ Tons}$$

$$R_2 = ((78' - 3') \times 1100 \text{ tons}) / (75' + 78' - 3') = 550 \text{ Tons}$$

The following problem illustrates the importance of the smallest details of a lift, even the placement of cribbing under the load. Ideally, cribbing should be as close as possible to the lift points or slightly inside. Here, the cribbing is to the outside of the pick points and illustrates how the loads to the support points, no matter if it is the ground or a lifting device, redistribute its self.

Determine forces R_1 and R_2 for 1100 ton splitter column during upending operation.

$$\sin 48.5^\circ = 0.75 \text{ +/-}$$

$$\cos 48.5^\circ = 0.667 \text{ +/-}$$

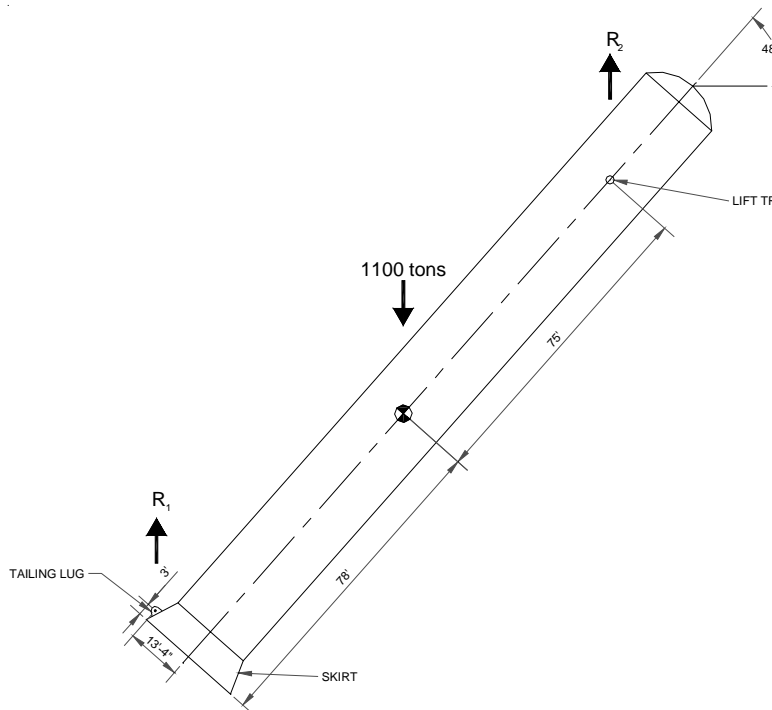

$$R_1 = (75' \cos 48.5^\circ \times 1100 \text{ tons}) / (150' \cos 48.5^\circ + 13'-4'' \cos 48.5^\circ) = 500 \text{ tons}$$

$$R_2 = ((75' \cos 48.5^\circ + 13'-4'' \cos 48.5^\circ) \times 1100 \text{ tons}) / (150' \cos 48.5^\circ + 13'-4'' \cos 48.5^\circ) = 600 \text{ tons}$$

Determine the forces on Crane 1 and Crane 2 before load is lowered on to cribbing, and a load first touches down. Again, assume that the load remains level.

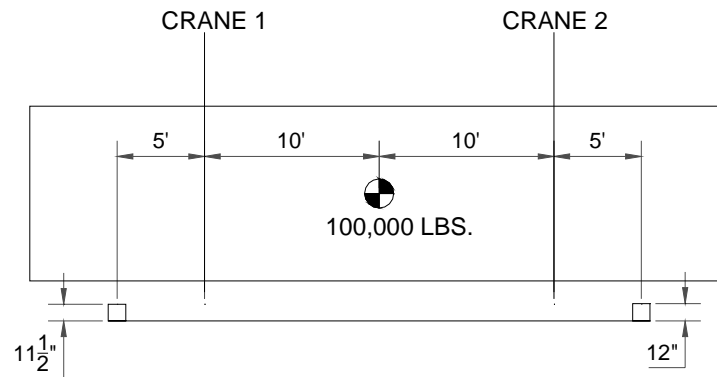

$$CRANE 1 \ \& \ 2 = (10' \times 100,000 \text{ lbs}) / 20' = 50,000 \text{ lbs}$$

$$CRANE 1 = (15' \times 100,000 \text{ lbs}) / 25' = 60,000 \text{ (20\% Increase in load!)}$$

Jobsites with large components usually require taking items from a horizontal position to a vertical position. During this type of operation, the relationship between the pick points and the center of gravity is very important. Sample problem below illustrates how the load is transferred in an upending operation. Here, the greater the offset of the tailing lug **above** the centerline, the earlier and smoother the transfer of load to the lifting lugs will be. If there is no offset, no load will transfer until the piece is vertical; in which case, it happens all at once. Conversely, if the tailing lug is **below** the centerline, the load will shift toward the tailing lug and create a dangerous and unstable condition during upending.

2.3 SLINGS

One of the main components of any rigging arrangement is the sling or “choker.” Slings come in any number of shapes, sizes, capacities, and types. The main types are wire rope, nylon, polyester round, chain, and wire mesh. Wire rope used in rigging is typically 6 x 19 or 6 x 37 class, and all types must meet ASME B30.9 criteria. All slings, regardless of type, must have a legible tag stating, among other things, its safe working load (SWL) when in a straight pull. The SWL does not account for how the sling is to be used, whether in a choke or basket hitch or on an angle. When placed in a choker configuration, the sling could be derated as much as 30 percent, while a true basket hitch (where both legs are vertical) will have twice the rated capacity.

2.3.1 Basket Hitches and D/d

One catch to the basket hitch that is often missed is what is called the D/d ratio. When a sling is bent around something with a large diameter, the outer pieces of the wire rope stretch very little. However, when the sling is bent around a small diameter, the outer pieces will stretch greatly, thus requiring a reduction in capacity. To determine this reduction, the D/d ratio must be calculated and then looked up in a table such as Table 2.3-1. The D is the diameter of the item that the sling is bent around, and the d is the diameter of the sling. For example, a 1.5 inch sling has an SWL of 21 tons and will bend around something that is 6 inches in diameter weighing 37 tons. If the D/d ratio is ignored, the capacity appears to be twice the SWL of 21 tons for a basket SWL of 42 tons. However, the D/d must be factored. Thus, 6 inches/1.5 inches = 4 inches. Now, as Figure 2.3-1 indicates, the efficiency is actually 75 percent of 42 tons or 31.5 tons. Thus, by calculating the D/d ratio before the lift, it can be determined that the proposed sling would be overloaded by 17.5 percent, and a larger sling can be recommended.

Table 2.3-1

Efficiencies of Wire Ropes Bent Around Stationary

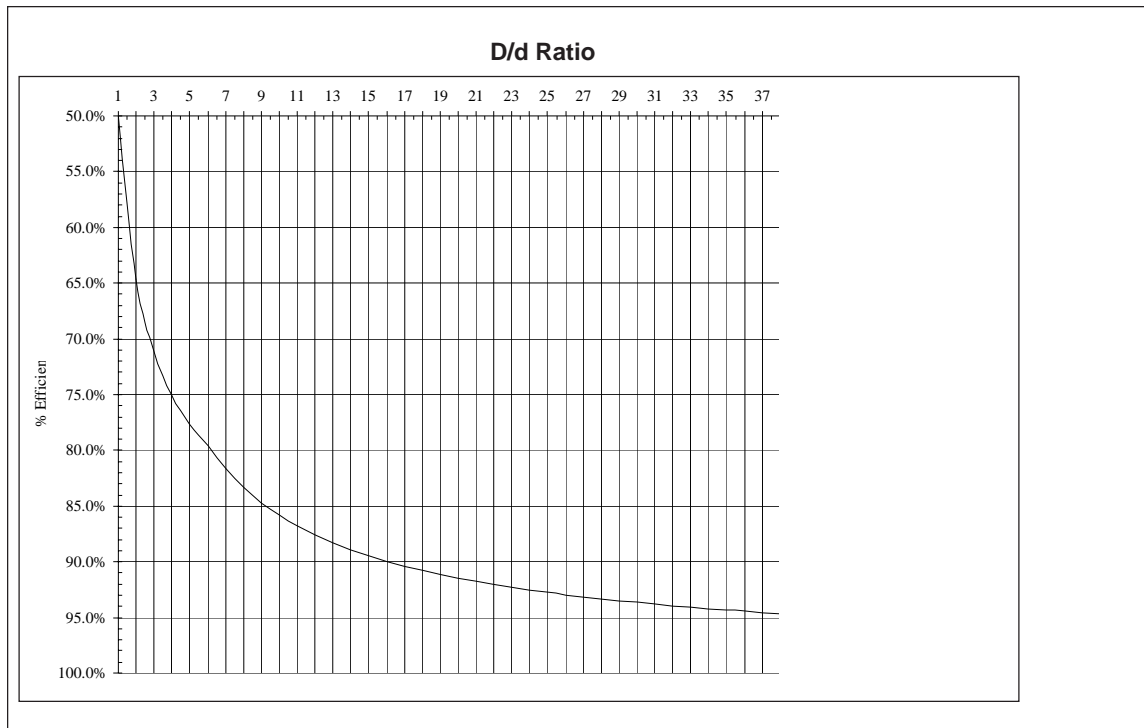

2.3.2 Sling Angle

Sling angle is another area where a sling may need to be larger than thought. Note that the SWL is in straight pull. When the forces on a sling act on an angle, the forces that affect the sling will actually be greater. In problem, the load is 50 tons symmetrically placed between two pick points.

Solve the following problems in accordance with ANSI/ASME B30.9

Determine the force in the following slings:

Force in Sling = 25 Tons / sin 60° = 28.87 Tons

$P=50$ tons

60° 60°

$P/2 = 25$ tons $P/2 = 25$ tons

2.3.3 Bridles and Center of Gravity

Most jobsites use bridles of three or more legs on a regular basis. These items, while very useful and versatile, can be easily overloaded if not sized properly. The most common reason stems from the following logic: There are four pick points; thus, each leg gets 25 percent of the load. However, assuming that the center of gravity is symmetrical to the lift points and that four or more pick points go to a single point, it is “statically indeterminate.” *Statically indeterminate* means that the true load in each sling cannot be mathematically determined. In reality, only two opposite slings actually take any load, while the other two slings just help balance. Other factors contribute to this as well such as one leg being longer/shorter than the other or lugs not at the same elevation. To solve this problem, the bridle must be sized so that only two legs can handle the load or a spreader must be used.

3

CRANES



3. CRANES

3.1 INTRODUCTION

Cranes are distinguished from jacks and simple hoists in that they not only have the capability of lifting a load but also can move a load horizontally and set it down again. The operation is usually performed with a hook and line from above the object being moved. Cranes can be classified into several broad categories such as mobile cranes, tower cranes, derricks, bridge/gantry cranes, container cranes, barge cranes, etc. This section focuses on common cranes that are used at typical construction sites such as mobile cranes, tower cranes, and derricks. Tower cranes and derricks are referred to as *fixed* cranes.

Tower crane and mobile crane design is continually improving, which greatly increases their lifting capacity and have made them an invaluable tool in heavy rigging work operations. The following sections expand on these and other features of construction cranes and provide a better basis for selecting an appropriate crane for a particular construction job.

3.2 MOBILE CRANES

Mobile cranes are characterized by the fact that they are designed to move, or *travel*, about the jobsite relatively easily. They are mounted on either wheels or crawlers and usually do not require a special permanent foundation from which to lift. Crane mobility permits a minimum amount of time for move-in, setup, and move-out. Mobile crane manufacturers have incorporated features that allow rapid setup times on site such as self decking and undocking uppers (for example, Manitowoc M250 and Link-Belt HC-286). Wheel-mounted mobile cranes can also propel themselves to the jobsite. Such site-to-site moves are called *transit* moves. Once on the jobsite, mobile cranes can be quickly moved to wherever they are needed. The size between the largest and smallest mobile cranes differs widely. In general, size is directly proportional to mobility. A 500-ton crawler-mounted mobile crane (not the biggest) may take several days to erect on site and to travel to the lift location. However, a 45-ton truck-mounted telescopic boom crane is ready when it arrives on site and can execute many lifts that same day.

Mobile cranes can be further classified by boom type and *carrier* type. Booms are either conventional *lattice truss* boom or *telescopic* boom. Virtually all telescopic boom cranes in use today use hydraulic cylinders to extend and retract the boom. Therefore, they are commonly referred to as *hydraulic cranes*. Each of these types of booms carries the load weight differently.

The lattice boom and its pendants, or backstays, form a triangle. The boom is a compression member, and the pendants are tension members. The structural system thus formed is very strong, rigid, and relatively light. Boom length can be increased significantly with little penalty in capacity for the added dead weight. The lattice boom is modular, and the length between the butt section and the tip section is increased by manually inserting short boom segments known as *inserts*. Inserts range in length from 10 to 40 feet and install quickly with pins. This procedure, however, must be completed with the boom laying horizontally on the ground and takes one or two ironworkers and a small assist crane.

Telescopic booms, on the other hand, carry their load as flexible, cantilevered box beams, much like fishing poles. As such, they are extremely strong and have a high lift capacity when almost vertical. (For high boom angles, the internal loading is mostly compression.) However, at low boom angles, the telescopic boom's capacity decreases rapidly because of limited bending capacity. In addition, at low boom angles, the dead weight of the boom contributes significantly to overturning. As with a fishing pole, deflection of a telescopic boom is significant even with low loads. The primary advantages of the telescopic boom cranes are portability and rapid setup time. Telescopic cranes are almost always mounted on wheeled carriers. The boom segments nest inside one another and are easily retracted to roadable lengths. Once at the site, the boom can be extended to full length in a matter of minutes.

To extend reach height even further, lattice boom extensions are frequently added manually to the tip of the telescopic boom. Most European manufacturers can also provide an elaborate lattice extension called a luffing jib attachment, which essentially converts the crane into a tower crane.

Size effects play an important role in the time required for setting up a telescopic boom crane. The larger the crane, the longer the setup time required and the less mobile it is on site. Depending on local highway laws, when telescopic cranes reach the 180-ton range, additional trucks may be needed to carry counterweights. The setup time is still significantly shorter than that required for comparable lattice boom cranes. The largest telescopic cranes (800 tons and up) require additional trucks to carry boom, outriggers, and counterweight.

3.3 CARRIERS

A carrier is what makes a mobile crane mobile and basically consists of a special truck chassis, turntable, and wheels. Strictly speaking, crawler “carriers” are not usually referred to as carriers but rather *crawler bases* and consist of a structural frame called a *carbody*, a turntable, and crawler treads. The *upperworks* consist of the hoisting mechanisms, swing mechanisms, hoist engine, and boom mounting—all of which are fastened to a structural frame called the *machinery deck*. Via the machinery deck, the upperworks are mounted to the carrier’s (or crawler base’s) turntable. The upperworks of smaller cranes are permanently mounted to the carrier. For larger cranes, the upperworks or *house* is designed to be detached or *undocked* from the carrier to facilitate transit moves. See Figures 3.3-1 and 3.3-2.

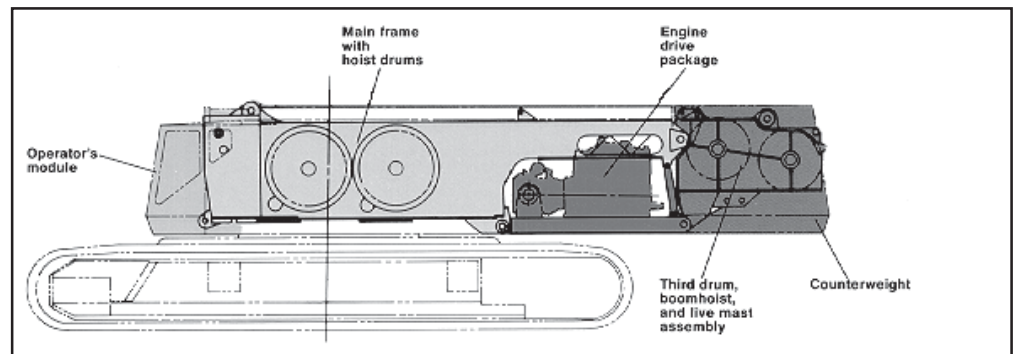

Figure 3.3-1 Upperworks of a Crane

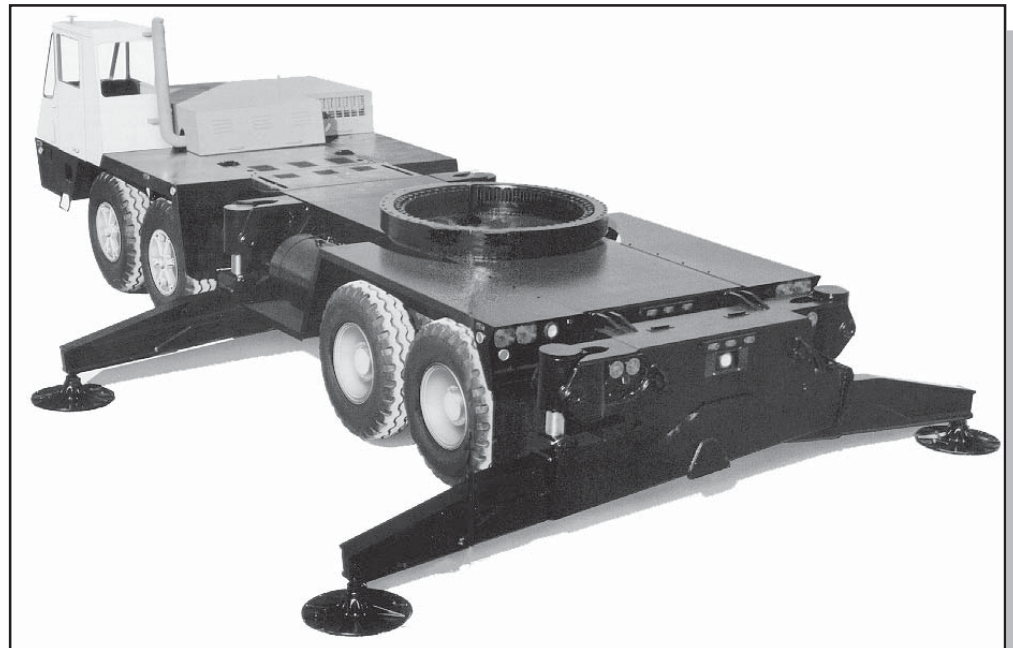

Figure 3.3-2 Truck Crane Carrier

Crawler carriers, or bases, are ideally suited for rugged jobsite situations. See Figure 3.3-3. Their large footprint provides a large ground-bearing area that is ideal for traveling along unfinished site roads or paths, especially with sandy soil conditions. Crawlers need to be trucked in and assembled on site. Smaller crawler-mounted cranes can be loaded on a truck fully assembled (excluding boom).

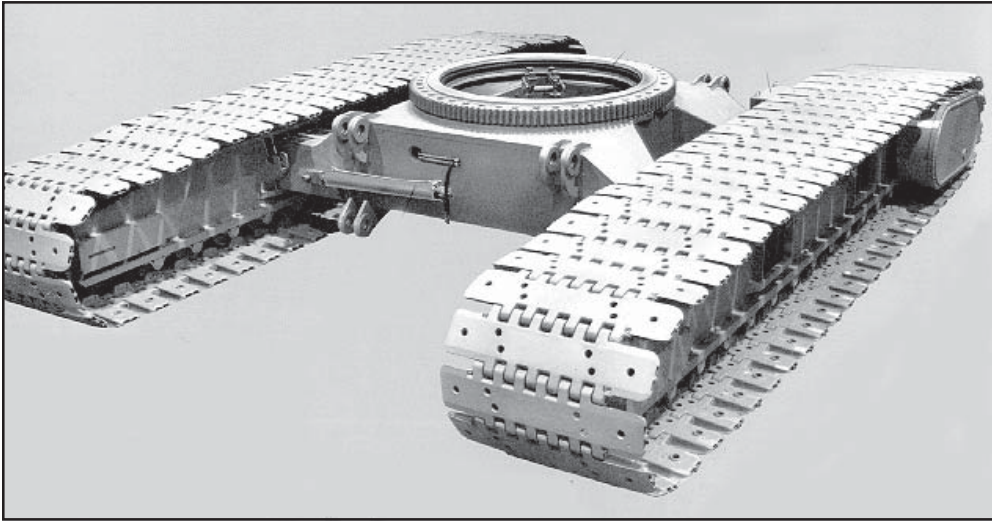

Figure 3.3-3 Crawler Base

The largest land-based mobile cranes available today are crawler mounted. These behemoths (1,000 tons and up) are mounted on crawlers because no other carrier type would provide sufficient or economical dead load weight distribution to the ground. These large cranes are not very maneuverable and take extensive time to assemble and transport.

Wheeled carriers come in three basic types. The first is called a truck carrier and has the ability to travel long distances on public highways. Its heavy-duty suspension and power train are designed primarily for highway travel and for graded jobsite roads. This carrier type has proven to be the most diverse. It provides a base for both lattice boom and telescopic boom cranes ranging in capacities from 5 tons to well over 500 tons.

A second type of truck carrier is the *rough terrain* (RT). The type of carrier has four oversized wheels and is designed strictly for off-road use because it does not have a separate driver's cab. The rear axle of a rough terrain carrier has an oscillating hydraulic suspension that gives it superior off-road travel capabilities. During pick and carry operations, the rear axle must be locked.

Finally, the most technically advanced type of carrier is the *all terrain* (AT) carrier. As its name implies, it is suitable for traveling on both highways and ungraded jobsite roads. This feature is achieved by a fully hydraulic, computer-controlled suspension and all-wheel steering for its multiple axles. It offers high maneuverability in confined urban settings.

All truck carriers are supplied with outriggers that must be fully extended when the boom of the crane is manipulated, whether it is loaded or unloaded. When setting the out riggers, all of the tires must be completely free of contact with the ground. The tires are considered part of the counterweight and are not effective as ballast if touching the ground.

3.4 FIXED, STATIC-BASED CRANES

Tower cranes and derricks are examples of fixed cranes. Not all tower cranes are fixed. Fixed cranes are characterized by requiring permanent foundations. The crane cannot be moved around the jobsite without being completely dismantled and reassembled.

A fixed tower crane consists of a machinery deck (upperworks) and jib (or boom) mounted atop a slender lattice tower. This arrangement provides unobstructed boom clearance over obstacles on the ground. The long jib (or boom) of a tower crane compensates for its lack of mobility by providing lift coverage to a large area of a site while occupying very little real estate on the ground. Where air space is also limited by adjacent tall buildings, such as in urban areas or congested jobsites, a luffing boom tower crane can provide lift capabilities while being able to boom up to go around obstructions. See Figures 3.4-1 and 3.4-2.



Figure 3.4-1 Horizontal Jib Tower Crane



Figure 3.4-2 Luffing Jib Tower Crane

Tower crane manufacturers have simplified the tower erection process. The lattice towers are designed to break down into roadable lengths and widths. On site, a moderately sized assist crane is required to assemble the crane and machinery deck near the ground on a section of short tower. The tower crane is then designed to jack itself up to allow insertion of another

segment of tower. This process repeats as construction progresses upward. Dismantling proceeds in the reverse order. The tower needs to be braced every 100 to 150 feet by using guys or, preferably, by bracing back to the building structure. The tower can even be incorporated inside the building structure. See Figure 3.4-3.

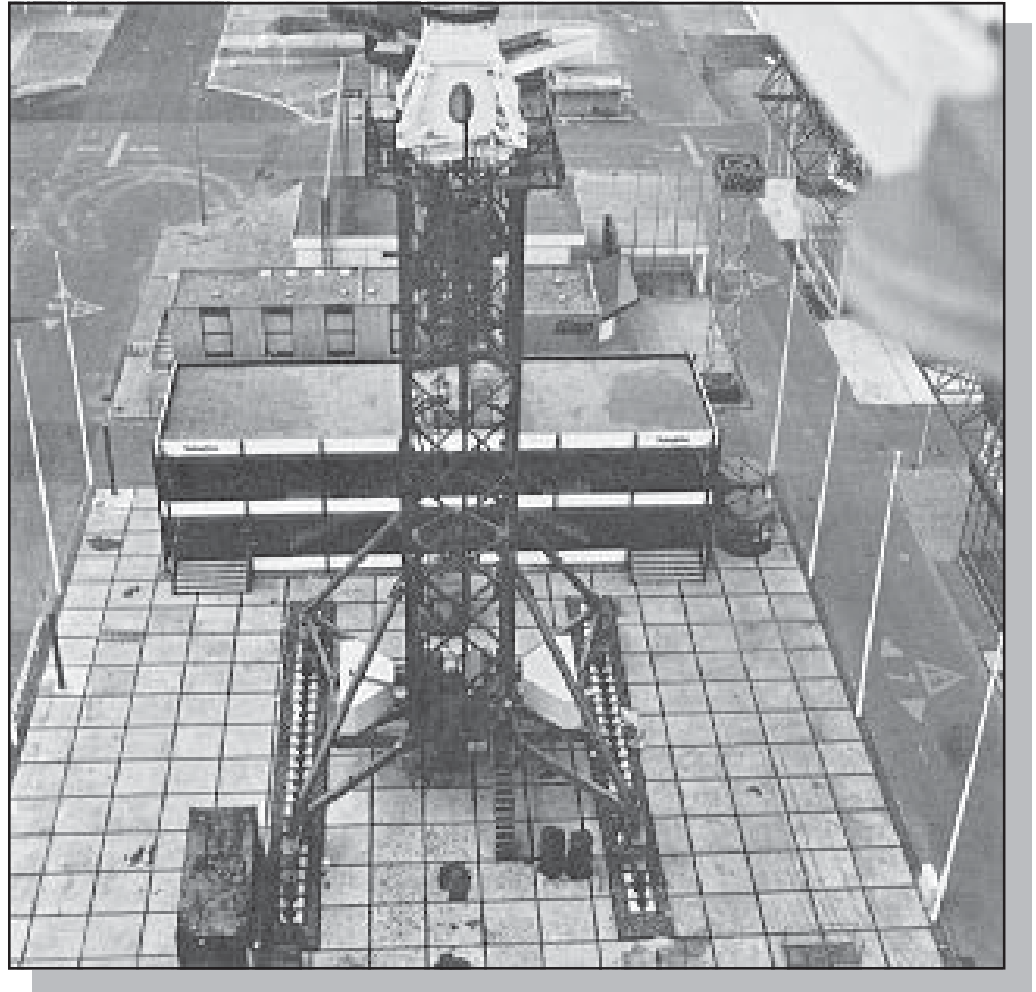

Figure 3.4-3 Aboveground, Fixed Base of a Tower Crane

Another type of fixed crane is a derrick. A guy derrick is depicted in Figure 3.4-4. The boom is typically a conventional lattice boom and the mast backstays or legs are rigid members (stifflegs) as opposed to wire rope guys. The boom and mast butts are mounted on a turntable and the stifflegs pin into fixed foundations. Stiffleg derricks range in size from 30 tons for rooftop-mounted models to more than 800 tons for ground-based models. The ground-mounted models typically require a steel support tower and large concrete mat or pile foundations. Some stiffleg derricks can be mounted on rails for limited site mobility but require ballasting.

A guy derrick uses wire rope guys to tie back the top of the mast. The guys are anchored to large concrete foundations. Erecting the mast and guys can be difficult at existing facilities because guy laydown space must be provided. Guy derricks are not ideal for use on crowded sites or in existing plants. Properly tensioning the guys can be a time-consuming operation.

Small rooftop derricks offer inexpensive lifting capability in congested areas. With good planning, they are quick to install, move, and dismantle. The large stiffleg derricks and guy derricks have the advantage of large lift capacity at a very long radius. Because they are fixed to their foundation, there is no possibility of tipping. See Figure 3.4-4.

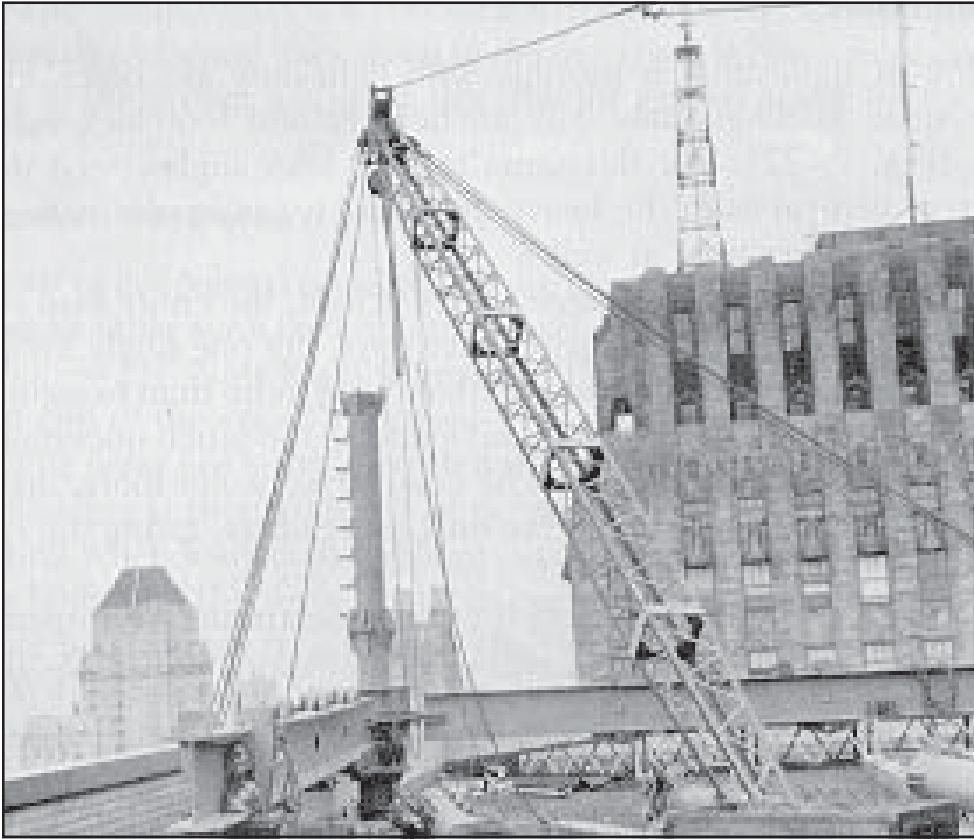

Figure 3.4-4 Small Guy Derrick Mounted on Rooftop

3.5 AVAILABLE CRANE COMBINATIONS—TELESCOPIC BOOMS

3.5.1 Rough Terrain Cranes

All rough terrain cranes feature hydraulic telescopic booms. The carrier suspension is designed exclusively for off-road use and high maneuverability. As such, there is only a single operator/driver cab. They are ideally suited for quick, light tasks around the jobsite. Rough terrain cranes must be transported to the site by truck. Either a single or double drop trailer is required, and they are ready for use as soon as they arrive. They range in capacity from about 15 to 80 tons.

However, the load capacity decreases rapidly at longer radii because of the dead weight and limited bending capacity of the boom. Maximum main boom lengths available are about 110 feet. The reach height can be increased by another 40 to 60 feet by installing a tip extension (jib). The tip extensions are easy to install and are stored or folded against the base of the main boom. Note that Grove and Link-Belt have different but overlapping terminology for this extension. Link-Belt manufactures two different types for each of its cranes. Verify with the crane operator what extension is being used and then carefully examine the load charts. The terminology is confusing and becomes more severe with truck-mounted telescopic cranes, so *beware*.

A separate load chart is provided for *stationary* lifts on tires (on rubber). Further reduced load charts are available for *pick and carry* situations. For both stationary lifts on tires and pick and carry lifts, the rear axle must be fully locked and the boom must be pointed directly over the front. When traveling with a load, the outriggers should be fully extended and “floating” a few inches off the ground. See Figure 3.5-1.

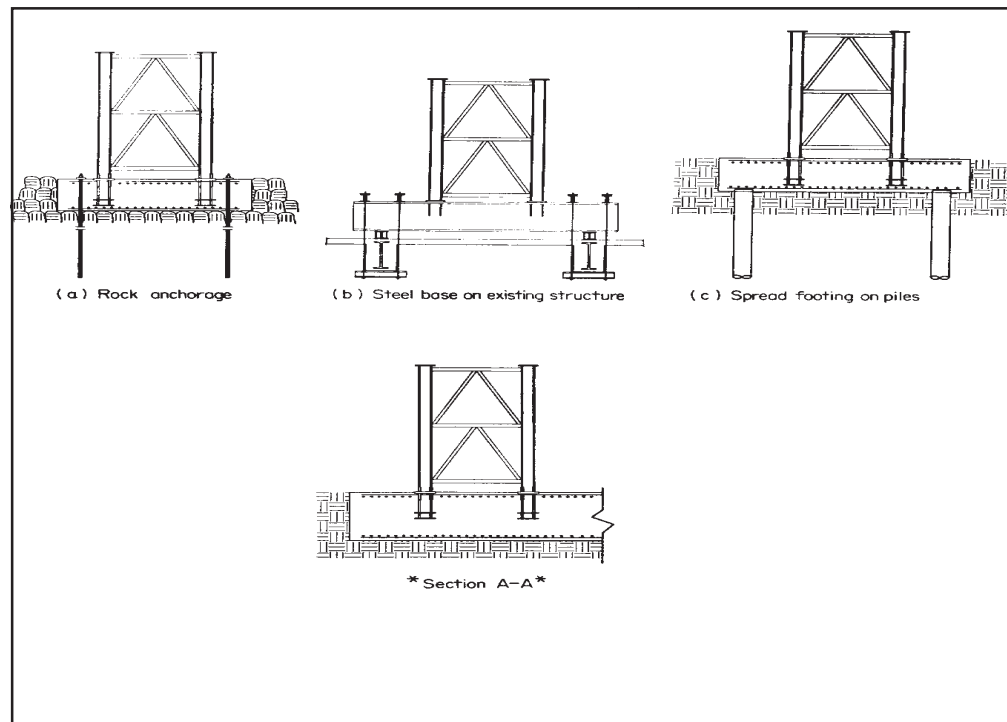

Figure 3.5-1 Rough Terrain Crane

Rough Terrain Load Chart Pointers—Read and understand all notes on the load chart.

Telescopic boom charts often have lengthy notes and restrictions. They are there for a purpose and must be read and understood.

Chart deductions (deducts) vary based on where the removable boom extension is stored and whether or not it is erected. Make sure that you know where the extension will be.

Telescopic boom charts, in general, do not account for increased radius under load. Because of their flexibility as cantilevered bending members, a telescopic boom acts like a fishing pole under load and deflects easily up to several feet, even when unloaded. This is important to remember when picking a load at near capacity and in situations where the boom could strike an obstruction as it is being loaded (i.e., picking an object from a rooftop without leaving sufficient clearance to the parapet).

A boom **should not be extended** or a crane **should not be operated** in a position not listed in the load chart. The telescopic boom is heavy and could cause the crane to inadvertently tip over, even if not loaded. See Figure 3.5-2.

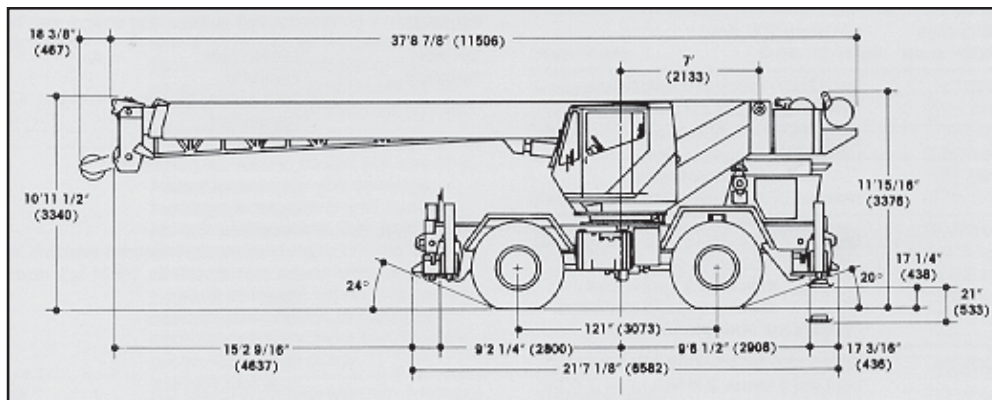

Figure 3.5-2 Rough Terrain Crane

3.5.2 All Terrain Cranes

All terrain cranes feature hydraulic, telescopic booms and have been perfected by the European crane manufacturers. There is an operator's cab and a separate driver's cab. The carrier suspension is advanced and allows for both on- and off-road travel capability. It consists of a series of interconnected hydraulic suspension rams at each wheel. Springing and damping are accomplished via air chambers within the hydraulic system. The industry markets the system under the name "hydropneumatic" or "hydrogas."

The computer-controlled suspension can be automatically adjusted to compensate for whatever terrain is being traversed. For example, the system can be made to automatically level the crane as it travels across inclined slopes or uneven roads. For lifting on wheels, the entire suspension must be locked out, similar to the rear axle of a rough terrain. All terrain cranes can transport themselves to the jobsite and are ready for use as soon as they arrive. They are ideal for short jobs in congested or urban areas. They range in capacity from about 30 to 800 tons. However, like all telescopic boom cranes, the load capacity decreases rapidly at longer radii because of the dead weight and limited bending capacity of the boom. The larger models have an advantage over lattice boom truck cranes because of their quicker setup time. They have an advantage over large crawler and ringer cranes because of their mobility. Presently, there is a large demand for these machines for just these reasons. See Figures 3.5-3 and 3.5-4.

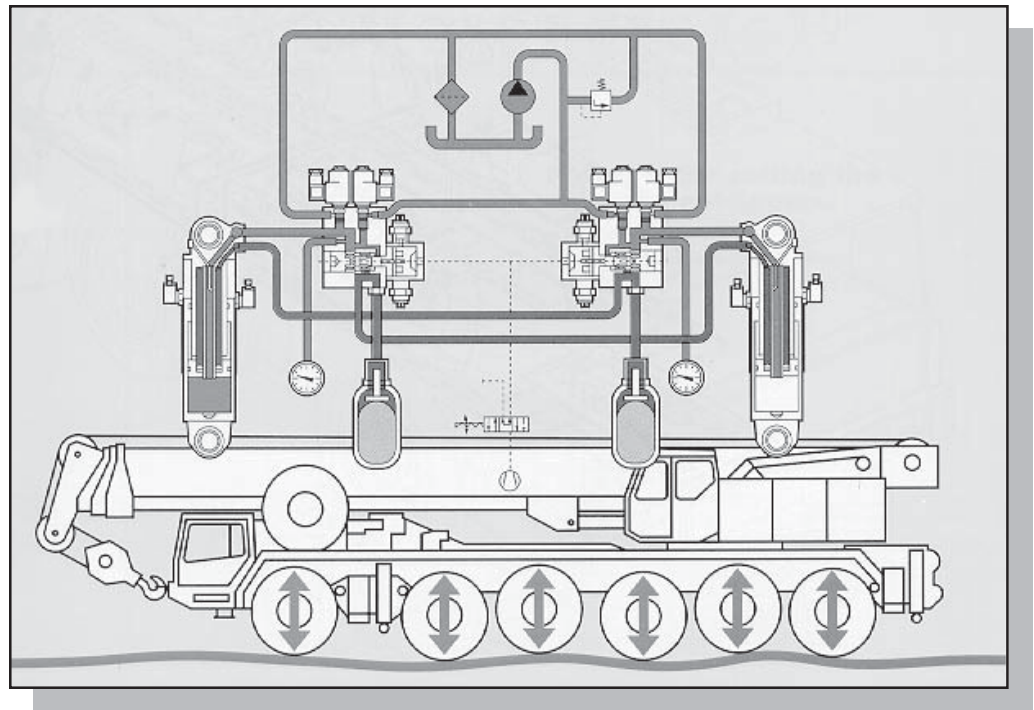

Figure 3.5-3 All Terrain Suspension, Top Shows Schematic of Hydraulic Suspension for One "Axle"



Figure 3.5-4 Al Terrain Crane

The large 800-ton models require extra trucks to carry the boom and counterweight. Maximum main boom lengths available are approximately 200 feet. The reach height can be increased by another 40 to 200 feet by installing a tip extension (jib). The tip extensions are generally lattice booms but require *less* ground assembly time as would a conventional lattice boom crane (no pendants). The other type of tip attachment unique to European all terrains is the elaborate lattice boom luffing jib. This jib increases the crane's radius significantly while still maintaining reasonable capacity at longer jib radii. The luffing jib essentially converts the crane into a mobile tower crane. The European manufacturers have put considerable effort in making these jibs quick and easy to erect. For example, it requires approximately 2 hours for an experienced crew to install an 80-foot luffing jib on the 185-ton Demag. Maximum capacities for luffing jibs, even for the largest basic cranes, are about 100 tons at the shortest radius and decrease slowly at larger radii. (This capacity is similar to conventional lattice boom cranes.)

All Terrain Load Chart Pointers—Telescopic boom charts, in general, do not account for increased radius under load. Because of their flexibility as cantilevered bending members, a telescopic boom acts like a fishing pole under load and deflects easily up to several feet, even when unloaded. This is important to remember when picking a load at near capacity and in situations where the boom could strike an obstruction as it is being loaded (i.e., picking an object from a rooftop without leaving sufficient clearance to the parapet).

Do not extend the boom or operate the crane in positions not listed in the load chart. The telescopic boom is heavy and could cause the crane to inadvertently tip over, even if not loaded. See Figures 3.5-5 and 3.5-6.



Figure 3.5-5 All Terrain Crane with Luffing

3.5.3 Truck-Mounted Telescopic Cranes

The truck carriers on these cranes are designed primarily for highway travel and for travel on graded site roads. Truck-mounted telescopic cranes are ideally suited for rapid turnaround work. These cranes can transport themselves to the jobsite and are ready for use as soon as they arrive. The larger capacity cranes may require a boom dolly for transportation to the site, depending on state highway regulations. They range in capacity from 20 tons to approximately 150 tons. However, the load capacity decreases rapidly at longer radii because of the dead weight and limited bending capacity of the boom. Maximum main boom lengths available are approximately 180 feet.

To reduce boom dead weight and increase chart capacity, manufacturers have paid very close attention to the *uppermost nested telescopic* boom segment. To reduce the weight there, manufacturers sell cranes with optional hydraulic extension cylinders in this boom segment. Terms such as *power pinned*, *tele-extension*, *manual extension*, or *full power* refer to the way this top-most nested boom segment is extended or secured in place. If you are not familiar with the particular machine, it is best to check with the operator or the load chart posted in the operator's cab to verify chart capacity. (Do not confuse this boom extension with the one described in the following section.)

Regardless of which uppermost boom segment is used, the reach height can be further increased by another 40 to 80 feet by installing a fully removable boom tip extension (jib). The shorter tip extensions install quickly and are stored or folded against the base of the main boom. Note that Grove and Link-Belt each have different but overlapping terminology for this extension and Link-Belt has several different types of jibs for each of its cranes. It is important to verify with the crane operator what extension is being used and then carefully examine the load charts.

Hydraulic Crane Load Chart Pointers—Read and understand all notes on the load chart. Telescopic boom charts often have lengthy notes and restrictions. They are there for a purpose and *must be read*.

Chart deductions (deducts) vary based on where the detachable boom extension is stored and whether or not it is erected. It is important to know where the extension will be.

Telescopic boom charts, in general, do not account for increased radius under load. Because of their flexibility as cantilevered bending members, telescopic booms act like a fishing pole under load and deflect easily up to several feet, even when unloaded. This is important to remember when picking a load at near capacity and in situations where the boom could strike an obstruction as it is being loaded (i.e., picking an object from a rooftop without leaving sufficient clearance to the parapet).

Do not extend the boom or operate the crane in positions not listed in the load chart. The telescopic boom is heavy and could cause the crane to inadvertently tip over, even if not loaded. See Figure 3.5-7.



Figure 3.5-7 Truck Mounted Hydraulic Crane

3.5.4 Lattice Boom Truck Cranes

Truck-mounted lattice boom cranes are choice for lifting in the 150 to 300-ton range although European models have capacities up to 600 tons. Load capacity at a large radius is good because of the light dead weight of the lattice boom. Main boom lengths up to 350 feet are available, and an extra 30 to 100 feet of reach can be accomplished by using a jib attachment. Lattice boom truck cranes are popular for use at existing plant turnarounds or any time a heavy crane is needed for several weeks or months. They offer quick transit times to the jobsite and relatively quick setup time once on site. They take longer to set up than hydraulic cranes but have significantly more capacity. Compared with crawler-mounted cranes, lattice boom truck cranes offer comparable capacity but much quicker transit times and setup times although with less mobility on site. The boom and counterweights need to be trucked to the site along with the carrier. Cranes with capacities roughly above 200 tons usually have upperworks (house) that are detachable from the carrier in order to make the load roadable. The carrier is self-propelled but the house can be self-loaded/unloaded onto a lowboy trailer for transit via four retractable hydraulic legs attached at the corners of the house. The house lifts itself clear of the trailer with its hydraulic legs. Then the carrier backs in under the raised house, which lowers itself onto the turntable. It then secures itself hydraulically to the turntable. Similar innovations allow the boom hoist gantry to assist in assembling the counterweights and in assembling the boom.

Truck-Mounted Lattice Boom Load Chart Pointers—Read and understand all notes on the load chart. They are there for a purpose and *must be read*.

There are usually at least two different types of boom top segments: hammerhead for low, heavy loads; and open-throat for normal operations. The proper load chart *must be read*.

There are typically chart deductions for various attachments to the boom tip such as auxiliary sheaves, jibs, and blocks. Assure that the crane configuration matches the chart being read.

Several different counterweight configurations are usually available for truck-mounted lattice boom cranes. Make sure that the appropriate counterweight is specified.

The crane **should not be operated** or the boom **should not be extended** to a position not listed in the load chart.



Figure 3.5-8 Lattice Boom Truck Crane

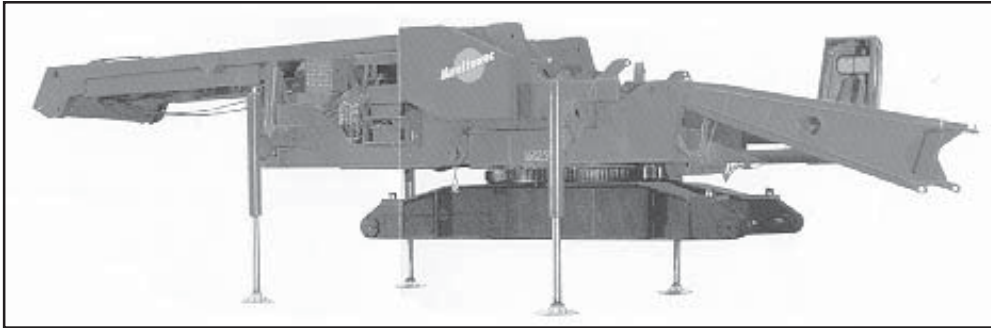

Figure 3.5-9 Self-Decking Upper

3.5.5 Crawler-Mounted Lattice Boom Cranes

Crawler-mounted lattice boom cranes display the largest range of lifting capacities, anywhere from 150 tons to greater than 1,000 tons. Load capacity at a large radius is good because of the light dead weight of the lattice boom. Main boom lengths up to 400 feet are available. An extra 30 to 100 feet of reach can be accomplished by using a jib attachment. Because of their high mobility over unfinished site terrain, crawler-mounted cranes are ideal for new construction work. Transit to the site and setup times can be lengthy compared with truck-mounted cranes of similar capacity. Crawler cranes can not be transported over public roads and must be trucked to the site in pieces and then assembled. Some manufacturers, such as Manitowoc, have designed newer models of crawler cranes with the ability to be highly self-erecting with minimal help from assist cranes, which greatly reduces the setup time required. See Figures 3.5-8 and 3.5-9.

Crawler cranes are highly versatile. Many different attachments are available and can increase their capacity, reach height, and radius. These attachments are discussed in a later section.

Crawler-Mounted Lattice Boom Load Chart Pointers—Read and understand all notes on the load chart. Telescopic boom charts often have lengthy notes and restrictions. They are there for a purpose and must be read and understood.

Usually, at least two different types of boom top segments are available—hammerhead tops (for low, heavy loads) and open-throat (for normal operations). Assure that you are using the proper chart.

The crawler tracks are retractable on some model cranes and allow for one-piece transportation, just as with truck crane outriggers. The crawlers must be fully extended when a lift is executed.

Typically, chart deductions exist for various attachments to the boom tip such as auxiliary sheaves, jibs, and blocks. The crane configuration must match the chart being read. Several different counterweight configurations are usually available for truck-mounted lattice boom cranes. Make sure that the appropriate counterweight is specified.

The crane **should not be operated** or the boom **should not be extended** to a position not listed in the load chart. See Figure 3.5-10.



Figure 3.5-10 Lattice Boom Crawler Crane

3.6 SPECIAL CRANE ATTACHMENTS

Many different attachments are available that use standard production cranes and that modify the cranes in some way to enhance lifting capacity, reach height, or maximum operating radius. The attachments are designed as economical alternatives to using the next larger crane. They do have unique features that may be ideally suited to specific lift and site requirements.

The most popular attachments are in this section and include tower attachments, ringer attachments, superlift or maxilift attachments, and the Skyhorse attachment.

3.6.1 Tower Attachment

A tower attachment to a mobile crane is an economical alternative to a traditional static-mounted tower crane. The primary advantage is that a permanent foundation is not required. Setup and transit time to the site are roughly identical to that required for the attachment's base configuration crane. A disadvantage, when compared with a traditional tower crane, is generally the lower capacities and shorter radius of the tower attachment. This is offset, however, by its free site mobility. If the radius or capacity is insufficient at one location, the crane can be easily moved to another location where it would be within capacity for that lift. Most tower attachments are available with fixed or limited vertical tower heights. Boom (jib) lengths from 100 to 200 feet are available and have luffing capability. See Figure 3.6-1.

Inspection and certification of mobile tower crane installations are much less complicated than for fixed base tower cranes. The operator and ironworkers erecting the crane are never in jeopardy because the erection and operation take place on the ground.

Lattice boom crawler cranes are popular for conversion to tower cranes. They have superior onsite mobility although setup and transit times are equal to those of the base crawler crane.

Although not marketed in the United States as tower attachments, European all terrain cranes with luffing jib attachments fill the definition of tower crane. The telescopic main boom is extended almost vertically and a lattice luffing jib is attached to the main boom tip. Capacity, maximum height, and radius are equivalent to those of crawler-based attachments. Truck-based tower attachments take slightly more time to re-setup at a different location on site than crawler-based models.

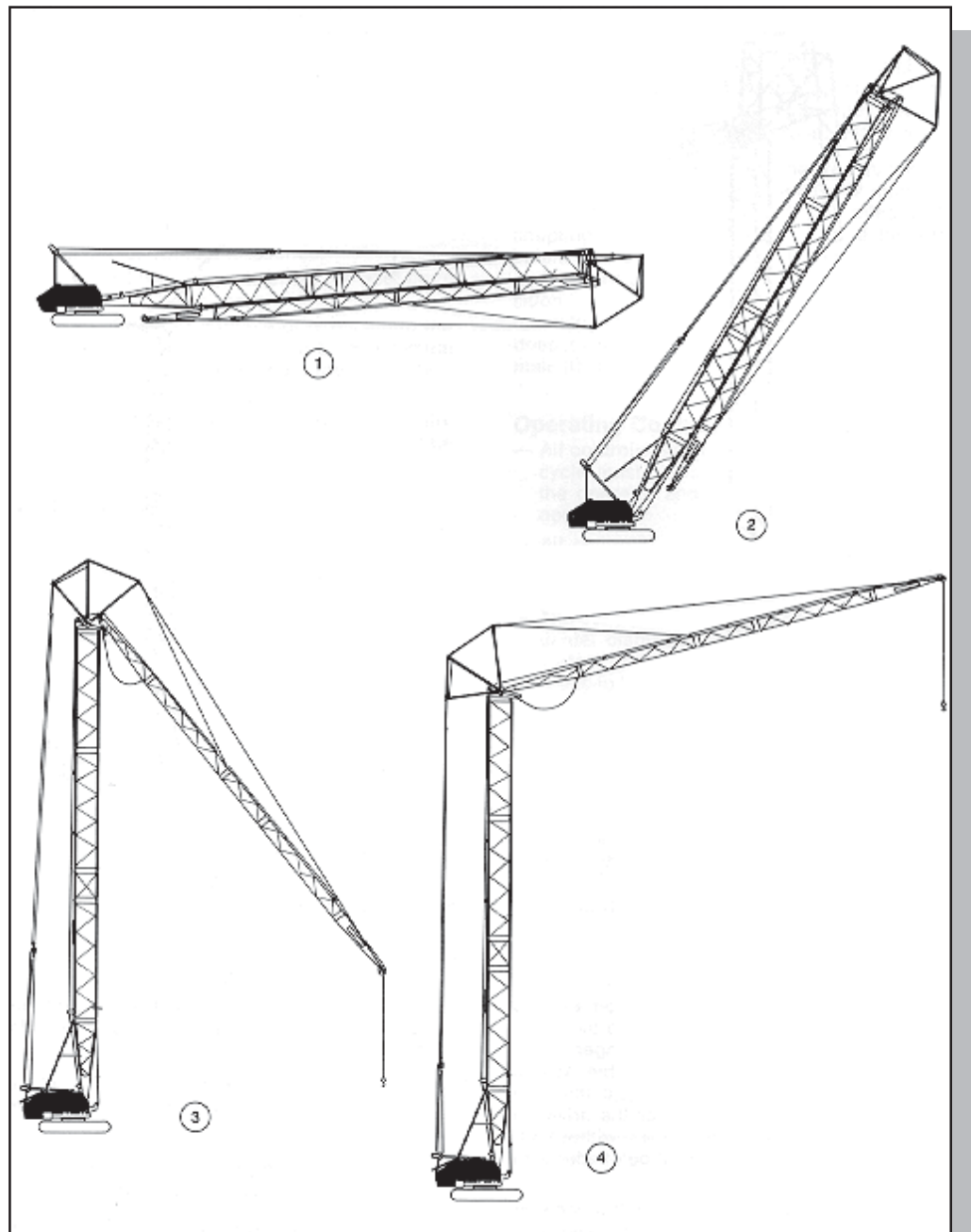

Figure 3.6-1 Tower Attachment Erection Procedure

3.6.2 Ringer Attachment

Ringer attachments are available for many large U.S. built lattice boom crawler cranes. They can more than triple the capacity and radius of the base crane. Capacities range from 350 to more than 750 tons. Boom lengths can be increased up to 400 feet. The basic configuration consists of the boom butt resting on an external turntable called the ring, which greatly increases the tipping fulcrum. The boom tip is tied back to a tall lattice mast to decrease the pendant forces. The crane's upperworks are mounted in the center of the ring. A large mass of counterweight rests on the ring (on rollers) at the rear when unloaded and hangs from the mast tip under load. See Figure 3.6-2.

Once set up, a ringer is not mobile. It takes 1 to 4 days to set up or move. Because the counterweight rests on the ring, the crane can swing when unloaded or under-loaded.

3.6.3 Superlift/Maxilift Attachments

Different manufacturers have different names for these attachments. The crane configuration is similar to the ringer in that the extra counterweight hangs from the lattice mast. There is no ring and the boom butt remains mounted directly on the upperworks or carbody. Under load, the counterweight is designed to be lifted from the ground. Unloaded, the counterweight rests directly on the ground. To swing the crane, the counterweight must be temporarily detached from the mast hangers. Likewise, if the crane booms up under load, the counterweight will contact the ground and a portion of it must be removed in order to swing. This type of crane attachment requires a large amount of lift planning. Transporting and stacking counterweight can also consume considerable time and expense.

Superlift attachments are found on larger European crawler cranes as a standard feature. They range in capacity from 300 to 1,200 tons. A ringer crane of comparable basic capacity will yield slightly better performance at longer radii because of its longer tipping fulcrum. Although most superlift cranes are crawler mounted, performance is sometimes enhanced with the use of outriggers.

Generally, separate charts exist for six or eight standard counterweight masses (100 ton, 200 ton, etc.). Higher capacities are attained by simply stacking on more and more counterweight.



Figure 3.6-2 Ringer Attachment



Figure 3.6-4A



Figure 3.6-4B Super Lift Configuration of a Crawler Crane

3.6.4 Sky Horse Attachments

American Crane calls its crawler crane superlift attachment the Sky Horse. A Sky Horse attachment consists of a steel tank filled with water or sand ballast that hangs from the mast. The steel tank is mounted on steerable rubber tires. Onsite mobility and flexibility are unsurpassed by any other heavy lift crane. This attachment allows the crane to both travel and swing simultaneously, with or without a load. Maximum load capacities range from 150 to 350 tons. Transportation and setup times are on par with the basic crawler crane configurations. The counterweight tank requires about 30,000 gallons of water.

There is also a Super Sky Horse attachment available that can increase capacity to 800 tons with excellent, large radius performance. Unlike the standard Sky Horse, the Super Sky Horse cannot simultaneously swing and travel under load.

3.6.5 Lampson Transi-Lift

The Lampson Transi-Lift is a specialized crane and not an attachment. It consists of a boom and mast mounted on a crawler base with the counterweight mounted on a separate crawler base a sizable distance rearward. This arrangement gives the Transi-Lift an outstanding tipping fulcrum. The machinery deck spans between and connects the two sets of crawlers. The two sets of crawlers give this crane a great deal of mobility on site, both loaded and unloaded. The largest Transi-Lifts are capable of lifting 1,500 tons or more at short radii and can still pick about 500 tons at 300 feet.

Needless to say, a Transi-Lift is quite expensive to move and erect on site but may be cost-effective for projects completing a large amount of modular, prefabricated construction. Lifting a small quantity of large modules considerably reduces the amount of field construction time. See Figures 3.6-3 and 3.6-4A and 3.6-4B.



Table 3.6-1 Crane Selection Matrix

Within each crane type there may be variations, the average crane of that category is considered.

Type of Crane	Telescopic Boom cranes				Lattice Boom Attachments			Special Lattice Boom			Tower			Special Cranes		
	Rough Terrain	All Terrain	Truck Crane	Lifting Jib Attachment	Truck Mounted	Crawler Mounted	Super Maxi-Lift	Ringer	Skyhorse	Horizontal Jib	Lifting Jib	Crawler Tower	Trans lift	Guy Derrick	Stiffing Derrick	
Range of Rated Capacity	20 t - 100 t	20 t - 200 t	20 t - 1000 t	10 t - 150 t	90 t - 400 t	90 t - 500 t	200 t - 1200 t	300 t - 750 t	150 t - 800 t	15 t - 70 t	75 t - 230 t	30 t - 150 t	2500 t	200 t - 800 t	200 t - 800 t	
Radius	short	medium	medium	long	long	long	long	long	long	long	medium	medium	very long	very long	very long	
Reach Height	low	medium	medium	high	high	high	high	high	high	very high	very high	high	very high	high	high	
Performance at Longest Radius	fair	fair	fair	good	good	good	very good	very good	good	good	good	fair	outstanding	outstanding	very good	
Transportation to Site	Single Truck	Set	Set	Truck for Boom	Truck for Boom	Many Trucks	Many Trucks	Many Trucks	Many Trucks	Many Trucks	Many Trucks	Many Trucks	Many Trucks	Many Trucks	Trucks	
Setup Time	rapid	short	short	short	medium	long	long	medium	medium	long	long	medium	very long	very long	very long	
Mobility on Site	high	high	medium	medium	medium	high	low	medium (see note)	medium (see note)	fixed (see note)	fixed	high	low	fixed	fixed	
Ability to Walk with Load	y	y	y	n	n	y	n	n	y	n	n	n	y	n	y	
Suitability for congested sites	excellent	good	good	excellent	good	good	fair	fair	good	good	excellent	excellent	poor	poor	good	
Notes										Tower base may be mounted on rails for limited mobility		Tower height is fixed				

3.7 MOBILE CRANE STABILITY AND LOAD RATINGS

This section deals with mobile crane capacities and load ratings. Mobile crane load ratings are governed by one of two modes of failure:

- Structural capacity of the boom or outriggers
- Stability (tipping)

The rated load, or chart value, at a particular radius is based on a percentage of the load that will cause failure of the crane by either tipping or structural failure. The percentage, or factor of safety, is stipulated by ASME B-30.5 when tipping is the mode of failure. The ASME tipping factors of safety are 75 percent for crawler cranes on crawlers and 85 percent for cranes on outriggers. Because of complexity, other codes (design codes) govern the factor of safety based on structural failure. Structural failure modes are not discussed here.

Thus, to determine a load rating (chart value), one must first determine the two load values that cause failure, one from tipping and one from structural failure. Then apply the appropriate factor of safety to each of the failure loads and choose the lower value. This will be the rated load for that radius.

3.7.1 Tipping Load and Conditions

The method of determining the load that will cause tipping is outlined in SAE J76S and basically consists of loading weight onto the hook so that the test crane begins to tip. There are stringent conditions under which the tipping test must be carried out. First the crane must be set up on a firm, level (within 1 percent) foundation. Second, the test load condition must be static. Dynamic effects from hoisting, lowering, or swinging must be completely eliminated or minimized. Similarly, the effects of wind must be eliminated by conducting the tests on calm days.

These conditions are the laboratory test conditions and, as such, do not truly represent conditions in the field. The laboratory conditions signify a consistent, repeatable, controlled, tipping value. The factor of safety is added to this baseline tipping value to yield the chart value or load rating for use in the field.

3.7.2 Tipping Load

The predominant factor controlling load ratings for cranes is stability against tipping. In the United States, crane load ratings are established when a crane load stability test is performed per SAE J76S under controlled conditions to determine the tipping load.

The tipping load is the hook load at a specified radius about a line called the tipping fulcrum, which causes the crane to tip. The crane rating is based on taking a percentage of the tipping load. In the United States and Canada, the ASME crane load rating is 75 percent for crawlers and 85 percent for truck cranes of the tipping load. In other industrial countries the crane load

rating is 66.67 percent and 75 percent, respectively. A crane will tip when the overturning moment (moment of the load and boom about the tipping fulcrum) becomes close to equal to the crane resisting moment (moment of the machine weight about the tipping fulcrum). A stability test is conducted for truck and hydraulic cranes when the machine is in a state of balance about its tipping fulcrum. At this condition, the entire weight of the machine and load is being supported on two outriggers.

Cranes are designed based on full structural rated loads with a 20 mph side wind and a side loading at the boom tip for 2 percent of the rated load. For the normal operating conditions, the above design parameters provide some allowance for the dynamic effects due to the boom swing and luffing.

3.7.3 Tipping Fulcrum Location for Crawler Cranes

Crawler cranes do not have a leveling device and normally operate on timber mats or on firm, level ground. The crawler's tracks are loose cast steel and their purpose is to provide runways for the track rollers and distribute the machine weight and load to the supporting surfaces. The track rollers define the position of the side fulcrum. The track opposite the tipping fulcrum is not effective in resisting the tipping. When operating over the front, the tipping fulcrum is located below the centerline of the idler or drive sprocket. See Figure 3.7-1.

The weight and center gravity location for various crane components can be calculated. From these data, the stability-based ratings for the crane can be calculated. The accuracy of the calculated stability ratings can be determined by actual testing, which is performed in accordance with SAE J76S.

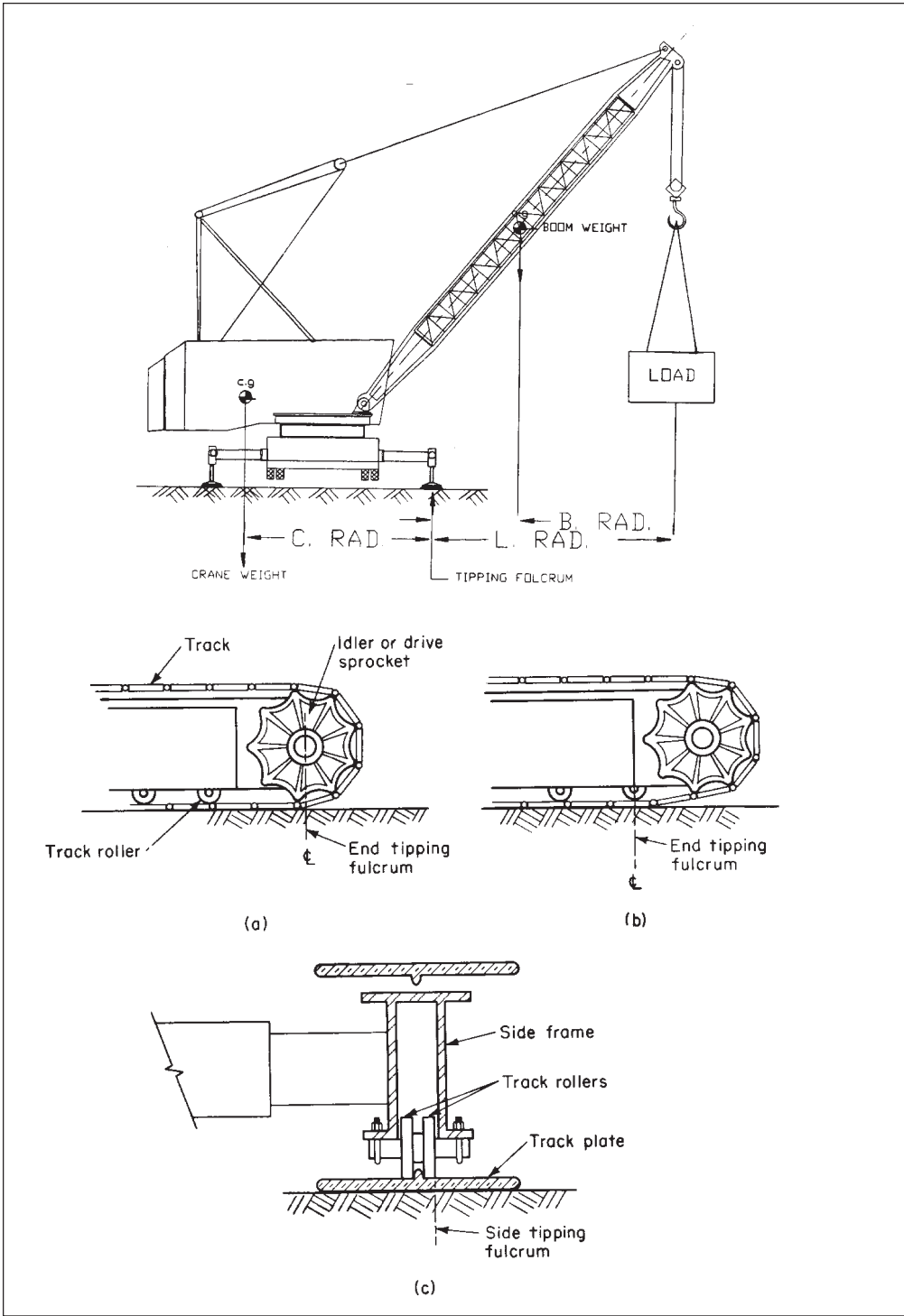

Figure 3.7-1 Tipping Fulcrum for Truck and Hydraulic Cranes

3.7.4 Tipping Fulcrum for Truck and Hydraulic Cranes on Outriggers

It is essential to raise the crane off of the tires and place it on fully extended outriggers to increase the crane's stability against tipping. By extending the outriggers, the side tipping lines are extended, thus providing a higher resisting moment against tipping. See Figure 3.7-2.

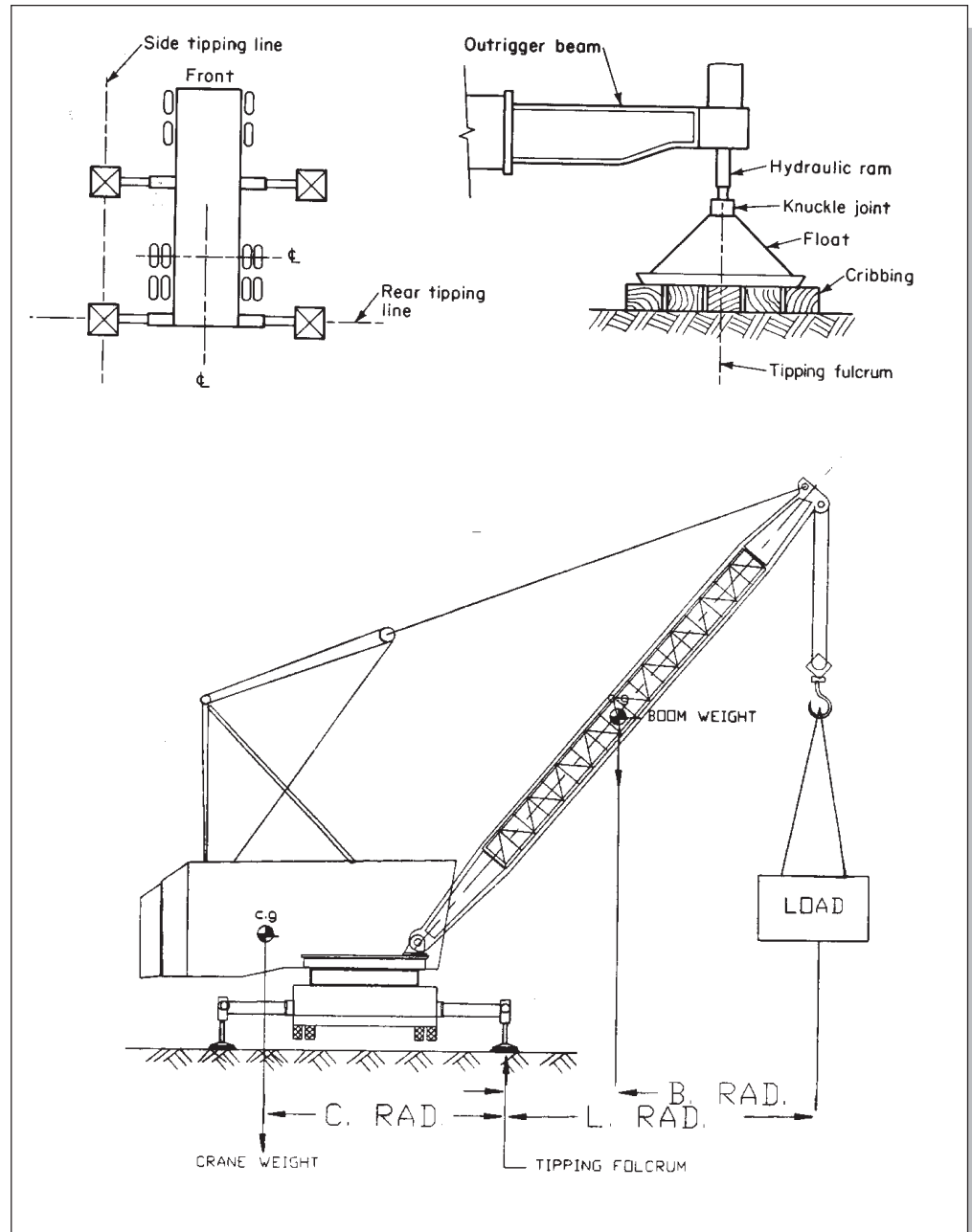

Figure 3.7-2 Tipping Fulcrum for Truck Cranes

At the construction site, occasionally, cranes are operated improperly with outriggers not fully extended. This could be due to lifting light weights or due to the side condition restraining outriggers for full extension. The following example illustrates the significance of extending the outriggers in regard to the stability.

Example:

A truck crane with 143 feet of boom at 125 feet radius is lifting over the side.

Determine:

- a) Tipping load
- b) Tipping load when outriggers are 1_ feet short of their full extension
 - Wc = Weight of crane 220,000 lb
 - Wb = Weight of boom 24,000 lb
 - B = Boom center of gravity of 52 feet
 - C = 17 feet, from crane center of gravity to tipping fulcrum (centerline of outrigger)
 - L = 114.5 feet, distance from load to tipping fulcrum

Stability relationship of above:

- a) Load x L + boom weight x B = crane weight x C
 Tipping load = $(220 \times 17 - 24 \times 52) / 114.5 = 21.7$ kips
- b) Outrigger less than 1_ feet from full extension:
 - C = 15.5 = 17 - 1.5
 - B = 53.5 = 52 + 1.5
 - L = 116 feet = 114.5 + 1.5
 - Tipping load = $(220 \times 15.5 - 24 \times 53.5) / 116 = 18.3$ kips, or 84 percent reduction of tipping load

The above exercise shows clearly why outriggers must be fully extended for lift stability.

Truck and hydraulic crane manufacturer lift crane capacity charts clearly state:

Do not exceed 85 percent of a static tipping load.

The 15-percent margin in the stability takes into account the dynamic load effects of swinging, hoisting, lowering, wind conditions, adverse operating conditions, and physical machine depreciation allowance. Therefore, not much margin remains for getting into the tipping condition. It is very important to observe and be totally familiar with the crane operating conditions and its limitations, as well as educating the crane operators to evaluate the effects of the above.

3.7.5 Tipping Fulcrum for Truck and Hydraulic Cranes on Tires

When cranes operate on tires, the tipping fulcrum is determined by evaluating the suspension or spring system.

Crane axles are pivoted to oscillate about the longitudinal centerline of the crane. The pivot controlling the position of the fulcrum line are shown as triangular. If blocking is used to prevent the tire deflation under the load, then the fulcrum lines become square. The broken lines in the diagrams in Figure 3.7-3 illustrate the fulcrum lines.

Without blocking, when the tires deflect under the load, the crane will tilt, which shifts the center of gravity of the crane closer to the tipping fulcrum. The tipping fulcrum for rough terrain cranes on tires with and without blocking are shown in Figure 3.7-3(a).

For a crane having two or more axles mounted on beams parallel to the centerline, where the beams being pivoted to the crane frame or wheel axle are fixed to the crane's frame body, the center of the tires will be the tipping fulcrum. See Figure 3.7-3(b).

For truck cranes with spring-mounted front axles, the spring position is considered to be the location of the fulcrum line. For truck cranes not spring mounted, but front axle pivoted to oscillate, the pivot controls the position of the fulcrum line. See Figure 3.7-3(c).

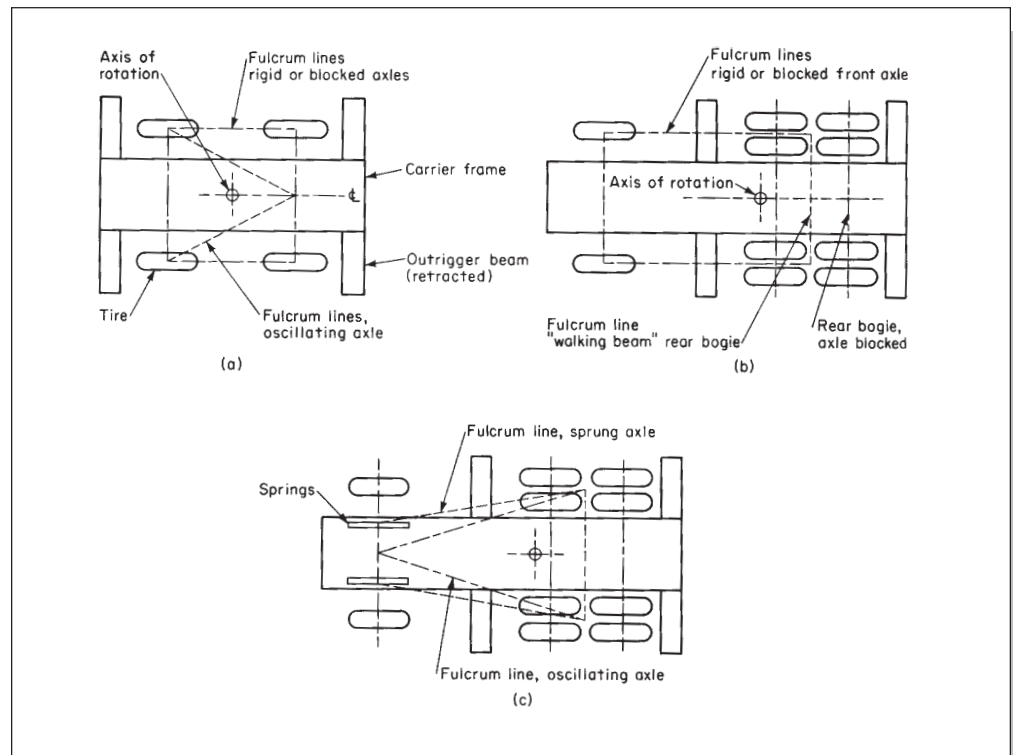

Figure 3.7-3 Crane Stability Lines

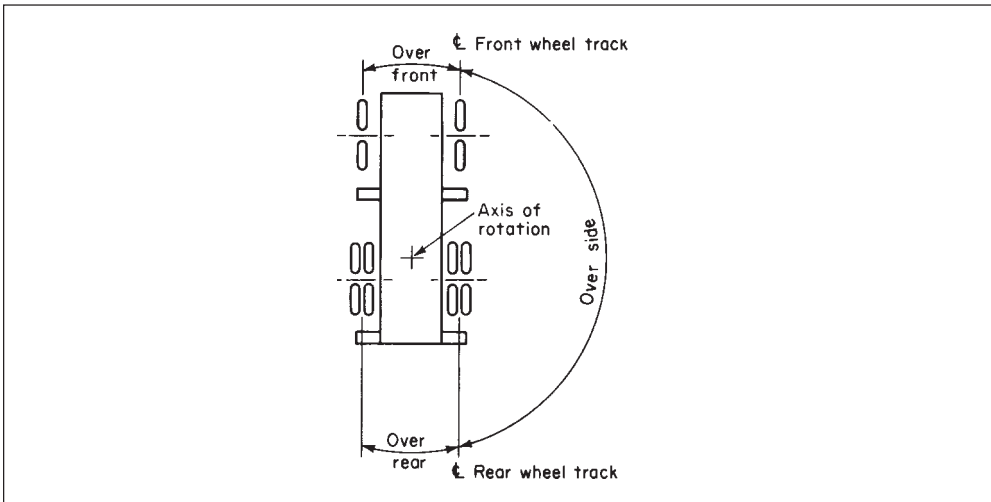

Figure 3.7-4 Crane Working Areas

The stability of the mobile crane on tires varies with respect to the boom's horizontal angle position to the longitudinal axis of the machine. Observation of the crane's center of gravity distance to the fulcrum line shows that when the boom is positioned at a 0 horizontal angle over the rear, stability is greater than when the boom is over the side or over the corner.

$$\text{Resisting moment } M_r = W_u \times d_u + W_c \times d_c$$

W_u and W_c are the weight of upper and carrier works, d_u is the horizontal distance from W_u to the center of gravity of the crane rotational axis, and d_c is the tipping fulcrum distance to the lower carriage center of gravity, which varies with respect to the position of the boom. For lifting over the side boom at horizontal angle a :

$$M_r = W_c \times d_{cs} + W_u \times d_u \sin a, \text{ for rating based on stability}$$

$$M_r = M_o \text{ tipping moment}$$

$$M_o \sin a = W_c \times d_{cs} + W_u \times d_u \sin a$$

$$M_o = W_c \times d_{cs} / \sin a + W_u \times d_u$$

This clearly shows that for any angle other than 90 degrees, the value of $\sin a$ will be less than 1, and, thus, the value of M_o will be higher. Crane manufacturer's load charts are based on the ASME B-30.5-1994 guideline showing the work area for mobile cranes on tires at only over the ends—rear or front—and over the side, which is somewhat conservative.

3.7.6 Crane Loads to the Supporting Surfaces

The reaction load from a crane's outriggers or crawlers to its supporting surface varies based on configuration and load. Variables to consider in calculating these reactions include type of crane, boom type and length, counterweight, radius of operation, slew or swing angle, jib configuration, etc.

The groundbearing pressure calculation is an estimate of the expected actual reaction load but is not exact because of the assumed ideal conditions such as zero mechanical deflection, infinite support rigidity, and perfect machine levelness. In addition, reactions are calculated based on static loading conditions and do not include dynamic load effects from swinging, hoisting, traveling, and wind conditions. To account for adverse operating conditions, sufficient design tolerances must be provided, based on the best judgment of the engineer.

The most crucial and time-consuming task in calculating crane reactions is determining the crane's correct center of gravity. This task typically involves consultation with the crane manufacturer because most charts, maintenance manuals, and sales documents do not show individual component weights or center of gravity locations. Some manufacturers, such as Manitowoc, have data sheets to assist in determining reactions at different load radii for their popular cranes. These data sheets, however, do not account for varying slew angles. Other manufacturers provide only a single maximum reaction for a particular crane.

In many cases, the exact bearing pressure is sought for a particular load, radius, and slew angle. The engineer must resort to analytical methods to determine the center of gravity and thus the reaction and ground bearing pressure.

Crawler cranes and truck cranes are treated differently because of the nature of their supports. Truck cranes typically have four discrete outriggers and require a straight forward static analysis, the results of which are four individual reaction forces. Crawler cranes require a more complex procedure because the reaction under the crawlers is a nonuniform pressure distribution.

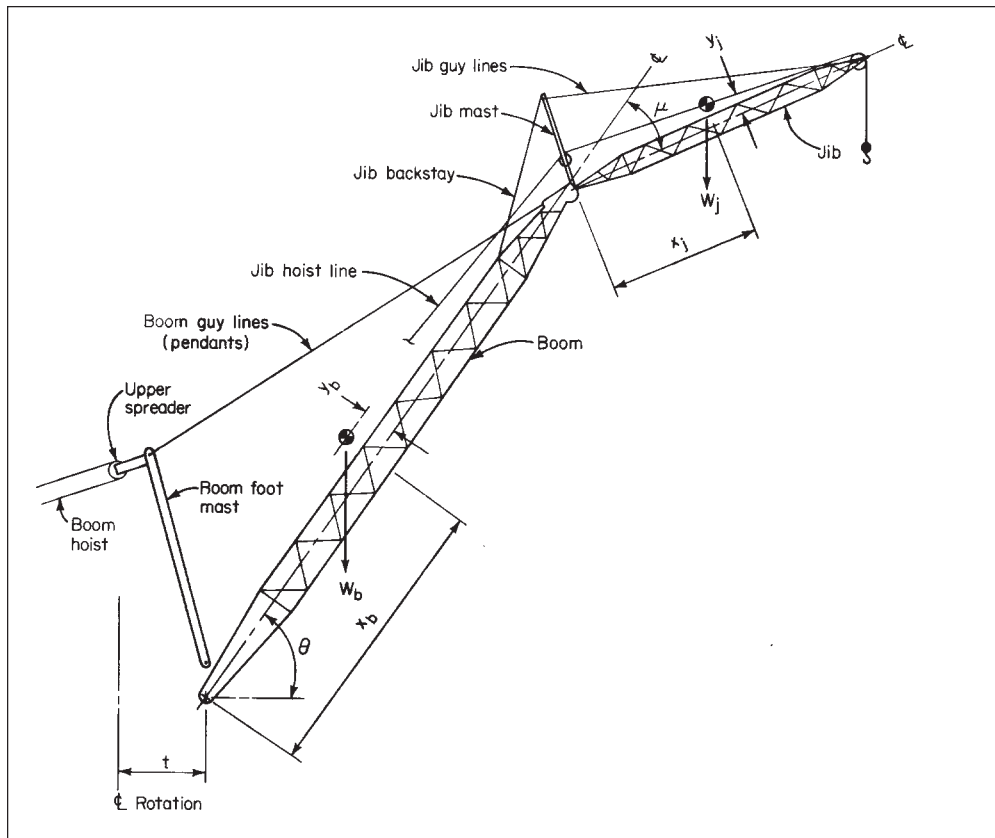

Figure 3.7-5 Lattice Boom CG Locations

3.7.7 Center of Gravity Calculation

The engineer must obtain the following information before attempting to determine the crane's center of gravity and reactions:

Carrier—Weight and center of gravity horizontal distance from the axis of rotation.

Upperstructure—Weight, including counterweights, and center of gravity horizontal distance from the axis of rotation.

Boom—For each boom length (both latticed and telescopic booms), weight and center of gravity location coordinates, including the effects of guy lines, upper spreader, and boom foot mast.

Jib—For each jib length, weight and center of gravity location coordinates, including the effects of guy lines and jib mast.

For boom and jib data, the center of gravity locations should be given in terms of a distance along the centerline measured from the foot pin and an offset above and perpendicular to the centerline. It is convenient to transform the boom and jib center of gravity location data from Cartesian to polar coordinate form.

$$\theta_b = \tan^{-1}(y_b/x_b)$$

$$L_b = (y_b^2 + x_b^2)^{1/2},$$

$$u_j = \tan^{-1}y_j/x_j$$

$$J_j = (y_j^2 + x_j^2)^{1/2}$$

where θ_b and L_b and u_j and J_j define the position of the boom and jib center of gravity respectively. If data are provided in polar form, the conversion step can be eliminated, of course. Polar data will allow the moment of the boom about the axis of rotation to be expressed as:

$$M_b = W_b[t + L_b \cos(\theta + \theta_b)]$$

and with a jib mounted, the moment becomes:

$$M_{bj} = M_b + W_j[t + L \cos \theta + J_j \cos(\theta - u + u_j)]$$

The entire crane structure above the swing circle can be replaced mathematically by a moment and a vertical load. If the weight of the upperstructure, less boom and jib weights W_b and W_j , is called W_u and its center of gravity is located horizontally from the axis of rotation a distance d_u , then the moment for operating radius R , including the lifted load W and the weight of the suspended hoist ropes W_r , is:

$$Mu = M_b + (W + W_r)R - W_u d_u$$

$$Mu = M_{bj} + (W + W_r)R - W_u d_u$$

when a jib is being used and the vertical load is given by :

$$V_u = W_b + W + W_r + W_u$$

or

$$V_u = W_b + W_j + W + W_r + W_u$$

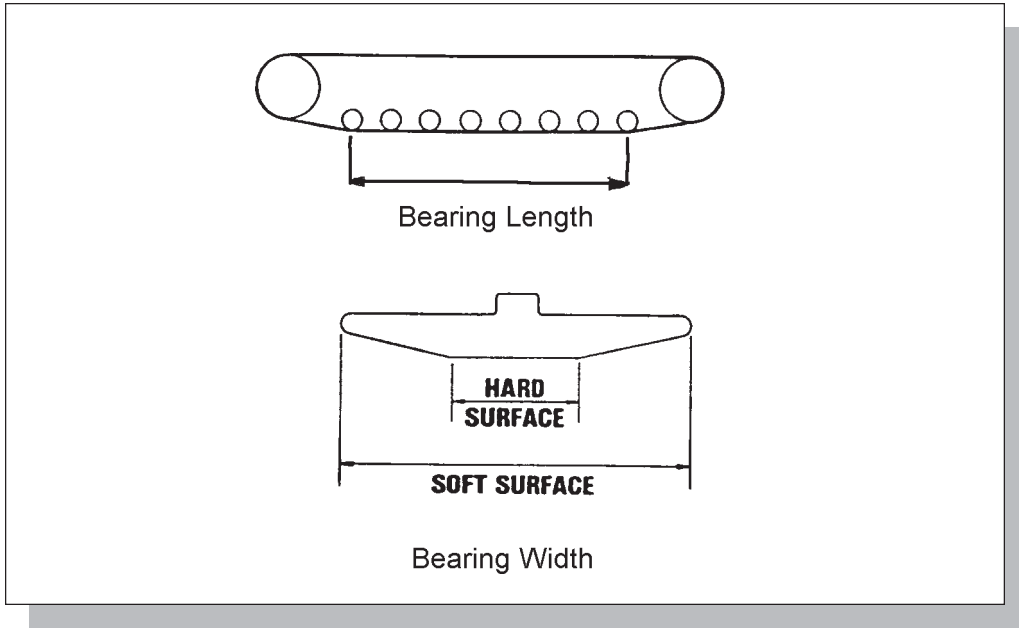

Figure 3.7-6 Crawler Bearing Surface

3.8 CRANE REACTIONS

3.8.1 Crawler Crane Reactions

The actual bearing reactions can be determined once the crane's center of gravity has been calculated. In normal practice, the crawler crane bearing surface is defined as the area of crawler tread that is in contact with the ground. This area is computed by multiplying the effective bearing length of each crawler by the width of the crawler tread shoes. Effective bearing length of the crawler is taken as the distance between center of the drive sprocket to the center of idler sprocket. (**Caution:** Some cranes have raised drive and idler sprockets. In this case, the bearing length is measured from the front-most to rear-most track roller.) The bearing width is generally the width of the tread. However, some manufacturers have sloped crawler edges. On soft surfaces such as earth, the full width may be used; for hard surfaces such as plywood on concrete, the bearing surface will be less. Figure 3.8-1 shows a Manitowoc 4100W-SII track tread detail.

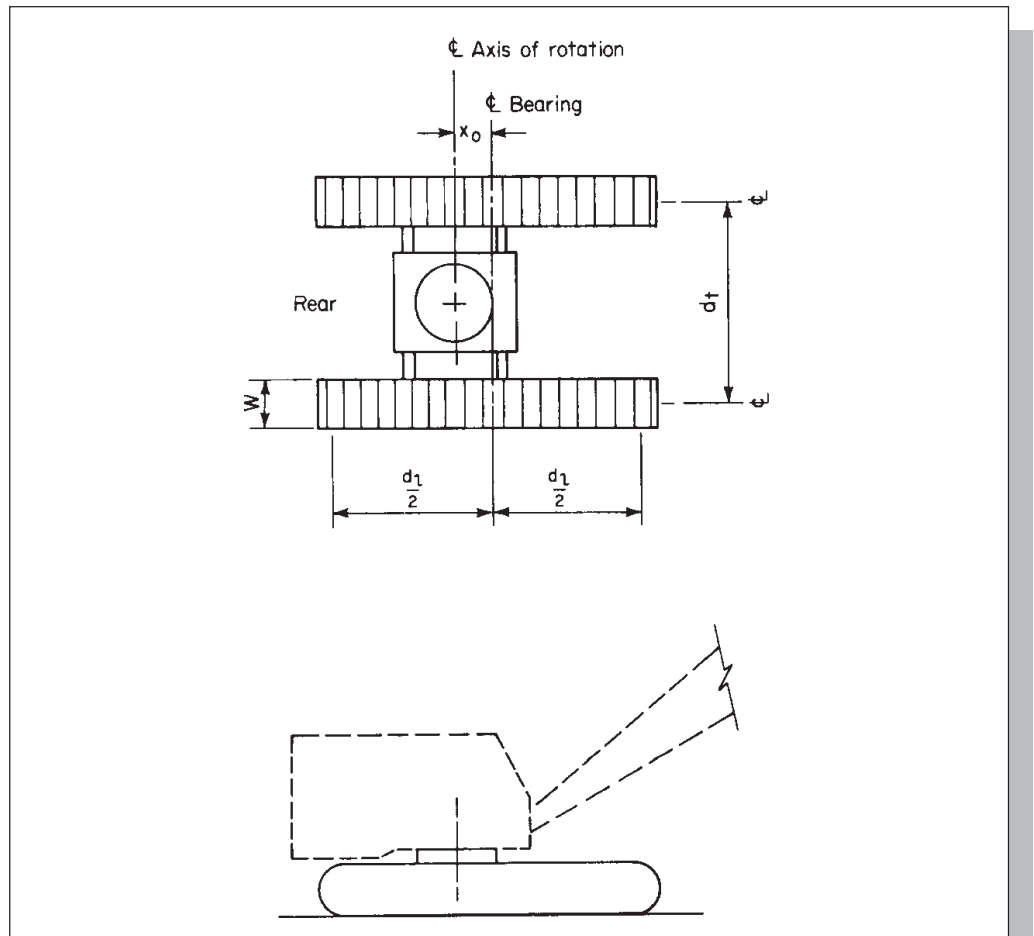

Figure 3.8-1 Crawler Geometry

3.8.2 Crawler Crane Example

The axis of rotation on the typical crawler crane passes through the centroid of the track bearing surfaces. On large machines, however, the axis is usually to the rear of the bearing centroid. (The rear is defined as the end containing the drive sprockets.) For generality, assume that the axis is at distance x_0 to the rear of that point. Let dl be the effective bearing length of the tracks, w the width of the tracks, and dt the center-to-center transverse distance between the tracks.

With the crane operating on a firm surface, the bearing length is taken as the distance between the drive and idler sprockets unless the machine is built with a raised idler. For those cranes, the bearing distance is taken from the center of the drive sprocket to the first track roller in contact with the ground. The bearing length can be increased for all cranes by installing blocking at the idler end. To make this effective, it is necessary to precompress the blocking by driving the unloaded crane onto it so that the blocking and the entire bearing surface experience crane weight.

When cranes operate on yielding soil, the tracks will press into the ground and bear on a larger area. In making track-pressure calculations, it is not prudent to count on this larger area. The yielding nature of the soil implies that caution must be exercised in evaluating support conditions. If the crane is permitted to tilt, a loss of stability and an increase in track pressure will follow.

With the boom at a horizontal working angle α from the longitudinal centerline, measured from the front, the net moments applied at the centroid of bearing are:

$$M_{nf} = M_u \cos \alpha - V_u x_0 - W_c d_c$$

over the front, assuming that the undercarriage CG is at distance d_c behind the bearing centroid, and

$$M_{ns} = M_u \sin \alpha$$

over the side. The total vertical load is

$$V = V_u + W_c$$

If the crane were perfectly balanced with respect to the centroid of the track-bearing surfaces, $M_{nf} = M_{ns} = 0$, the load would be equally shared between the tracks. Each track would carry $V/2$. But, if $M_{ns} \neq 0$ the distribution of load between the tracks cannot be equal. The difference in track loading must produce a ground reaction moment equal and opposite to M_{ns} .

Taking the reaction under the more heavily loaded track as R_h and under the more lightly loaded track as R_l :

$$V = R_h + R_l$$

The difference between R_h and R_l is caused solely by M_{ns} , which motivates the expressions:

$$R_h = V/2 + (M_{ns}/d_t)$$

$$R_l = V/2 - (M_{ns}/d_t)$$

The reactions (resultants) of the above equation satisfy the equilibrium requirements $\Sigma V = 0$ and $\Sigma M_{side} = 0$. What remains is to take into account the effects of the moment over the front, M_{nf} .

The front moment controls the longitudinal position of the resultants of the track reactions R_h and R_l . When $M_{nf} = 0$, there is no displacement; the resultants of track pressure are at the center of bearing of each track and each track experiences uniform pressure along its length. For non-zero values of front moment, the reactions are displaced:

$$e = M_{nf} / V$$

Because of eccentricity e , the track pressure diagram will take either a trapezoidal or a triangular shape.

The length l of the triangular pressure diagram is found by solving equilibrium equations for vertical load and front moment. For either track:

$$R = (P_{max})wl/2$$

$$e R = ((P_{max} wl)/2) - (d_t/2 - l/3)$$

which yields

$$l = 3 (d_t/2 - e)$$

$$l \leq d_t$$

For the triangular pressure diagram it follows that the maximum pressure is:

$$P_{max} = (2R)/(wl)$$

where R represents either R_h or R_l , depending on the track being studied.

When $l > d_t$ this indicates that the pressure diagram is trapezoidal. The difference between the pressures at the ends of the track comes about because of the front moment. Using the equilibrium condition $\Sigma M_{end} = 0$, the pressures at the ends of the track are:

$$P = (R/(w \times d_t)) \times (1 + 6e/d_t)$$

This analysis assumes that the crawler frames and carbody are absolutely rigid—not an unreasonable assumption for most machines. However, because of the rigidity assumption, both tracks will have a common value for e and will always have the same shape of pressure diagram, that is, both triangular or both trapezoidal. Actually, because of elastic effects, e will be the average displacement of the two tracks and small variations from the calculated pressures will be imposed on the ground.

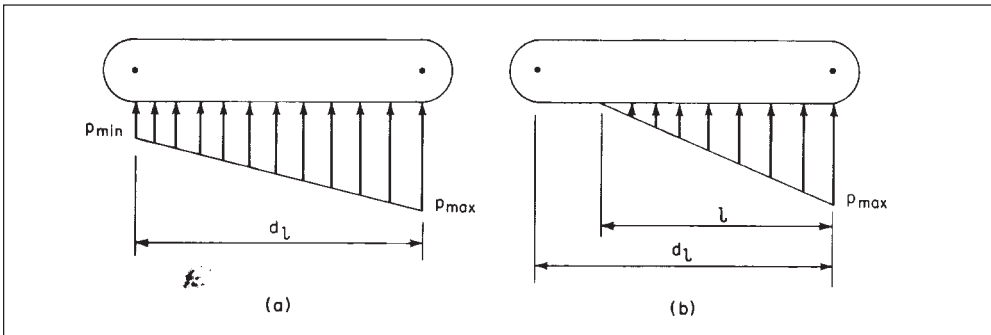

Figure 3.8-2 Crawler Bearing Reactions

Example:

Find the pressure under a Manitowoc 4100 S2 crawler crane equipped with 200 feet of type 22C boom, open throat tip, 146,400 lb upper counterweight, and 60,000 lb carbody counterweight, lifting a total load of 100,000 lb at a 50-foot radius. The load includes the weight of rigging, block, and wire rope.

Given:

$W = 100,000$ lb	Load weight
$R = 50$ ft	Load radius
$W_b = 35,100$ lb	Boom weight
$x_b = L_b = 104.4$ ft	÷
$y_b \nearrow 0$ ft	" Boom center of gravity, polar coordinates
$\theta_b \nearrow \theta = 76.7$ deg.	
$t = 4$ ft	Boom offset
$W_u = 206,050$ lb	Upper weight (including upper counterweights)
$d_u = 11.63$ ft	Upper center of gravity, including counterweight
$W_c = 186,822$ lb	Carrier weight
$d_c = 0$ ft	Carrier center of gravity
$x_0 = 0$ ft	Carrier offset from track centerline
$d_t = 17.7$ ft	Track centers
$d_l = 18.6$ ft	Track length
$w = 4$ ft	Track effective width
$x_0 = 0$ ft.	Carrier offset from track centerline
$d_t = 17.7$ ft.	Track centers
$d_l = 18.6$ ft.	Track length
$w = 4$ ft.	Track effective width

Example Case 1**Lifting directly over the front: ($\alpha = 0$ deg.):**

Boom moment

$$M_b = 35,100 [4 \text{ ft} + 104.4 \text{ ft} \times \cos (76.7 \text{ deg.})]$$

$$M_b = 983,000 \text{ lb-ft}$$

Upper moment

$$M_u = 983,000 \text{ lb-ft} + (100,000 \text{ lb}) \times 50 \text{ ft} - (83,650 \text{ lb} + 146,400 \text{ lb}) \times 11.63 \text{ ft}$$

$$M_u = 3,308,000 \text{ lb-ft}$$

Vertical load

$$V_u = 35,100 \text{ lb} + 100,000 \text{ lb} + (83,650 \text{ lb} + 146,400 \text{ lb})$$

$$V_u = 365,000 \text{ lb}$$

Moment over the front, about center of track ($\alpha = 0$ deg.)

$$M_{nf} = 3,308,000 \text{ lb-ft} \times \cos (0 \text{ deg.}) - 365,000 \text{ lb} \times 0 \text{ ft} - 186,822 \text{ lb} \times 0 \text{ ft}$$

$$M_{nf} = 3,308,000 \text{ lb-ft}$$

Moment over side ($\alpha = 0$ deg.)

$$M_{ns} = 0 \text{ lb-ft}$$

Total vertical load

$$V = 365,000 \text{ lb} + 186,822 \text{ lb}$$

$$V = 552,000 \text{ lb}$$

Track reactions

$$R_h = R_l = (552,000 \text{ lb} / 2) + 0 = 276,000 \text{ lb}$$

Pressure distribution eccentricity will be the same for both tracks

$$e = 3,308,000 \text{ lb-ft} / 552,000 \text{ lb}$$

$$e = 6.0 \text{ ft}$$

Bearing length, triangular if $l \leq dl$ or trapezoidal if $l > dl$

$$l = 3 \times [(18.6 \text{ ft}/2) - 6.0 \text{ ft}]$$

$$l = 10 \text{ ft}$$

$$10 \text{ ft} < 18.6 \text{ ft} \setminus \text{triangular distribution}$$

Maximum bearing pressure

$$p_{\max} = (2 \times 276,000 \text{ lb}) / (4 \text{ ft} \times 10 \text{ ft})$$

$$p_{\max} = 13,800 \text{ psf or } \underline{14 \text{ ksf}}$$

Example Case 2**Lifting directly over the side: ($\alpha = 90$ deg.):**

Moment over the front, about center of track ($\alpha = 90$ deg.)

$$M_{nf} = 3,308,000 \text{ lb-ft} \times \cos(90 \text{ deg.}) - 365,000 \text{ lb} \times 0 \text{ ft} - 186,822 \text{ lb} \times 0 \text{ ft}$$

$$M_{nf} = 0 \text{ lb-ft}$$

Moment over side ($\alpha = 90$ deg.)

$$M_{ns} = 3,308,000 \text{ lb-ft} \times \sin(90 \text{ deg.})$$

$$M_{ns} = 3,308,000 \text{ lb-ft}$$

Track reactions

$$R_h = (552,000 \text{ lb}/2) + (3,308,000 \text{ lb-ft}/17.7 \text{ ft}) = 463,000 \text{ lb}$$

$$R_l = (552,000 \text{ lb}/2) - (3,308,000 \text{ lb-ft}/17.7 \text{ ft}) = 89,000 \text{ lb}$$

Pressure distribution eccentricity

$$e = 0 \text{ lb-ft}/552,000 \text{ lb} = 0 \text{ ft}$$

\therefore uniform (trapezoidal) distribution

Bearing length, triangular if $l \leq dl$ or trapezoidal if $l > dl$

$$l = d_l = 18.6 \text{ ft}$$

Maximum bearing pressure

for R_h ,

$$p_{\max} = (463,000 \text{ lb})/(4 \text{ ft} \times 18.6 \text{ ft}) = 6,223 \text{ psf or } \underline{6.2 \text{ ksf}}$$

for R_l ,

$$p_{\min} = (89,000 \text{ lb})/(4 \text{ ft} \times 18.6 \text{ ft}) = 1,196 \text{ psf or } \underline{1.2 \text{ ksf}}$$

Example Case 3**Lifting directly over a corner: ($\alpha = 30$ deg.):**

Moment over the front, about center of track ($\alpha = 30$ deg.)

$$M_{nf} = 3,308,000 \text{ lb-ft} \times \cos(30 \text{ deg.}) - 365,000 \text{ lb} \times 0 \text{ ft} - 186,822 \text{ lb} \times 0 \text{ ft}$$

$$M_{nf} = 2,865,000 \text{ lb-ft}$$

Moment over side ($\alpha = 30$ deg.)

$$M_{ns} = 3,308,000 \text{ lb-ft} \times \sin(30 \text{ deg.})$$

$$M_{ns} = 1,654,000 \text{ lb-ft}$$

Track reactions

$$R_h = (552,000 \text{ lb}/2) + (1,654,000 \text{ lb-ft}/17.7 \text{ ft}) = 369,400 \text{ lb}$$

$$R_l = (552,000 \text{ lb}/2) - (1,654,000 \text{ lb-ft}/17.7 \text{ ft}) = 182,600 \text{ lb}$$

Pressure distribution eccentricity

$$e = 2,865,000 \text{ lb-ft}/552,000 \text{ lb} = 5.2 \text{ ft}$$

Bearing length, triangular if $l \leq dl$ or trapezoidal if $l > dl$

$$l = 3 \times [(18.6 \text{ ft} / 2) - 5.2 \text{ ft}]$$

$$l = 12.3 \text{ ft}$$

$$12.3 \text{ ft} < 18.6 \text{ ft} \therefore \text{triangular distribution}$$

Maximum bearing pressure

for R_h ,

$$p_{\max} = (2 \times 369,400 \text{ lb}) / (4 \text{ ft} \times 12.3 \text{ ft})$$

$$p_{\max} = 15,000 \text{ psf or } \underline{15 \text{ ksf}}$$

for R_l ,

$$p_{\max} = (2 \times 182,600 \text{ lb}) / (4 \text{ ft} \times 12.3 \text{ ft})$$

$$p_{\max} = 7,400 \text{ psf or } \underline{7.4 \text{ ksf}}$$

3.8.3 Truck Crane

To perform truck crane outriggers loading to the supporting surfaces, the following data of the crane are needed:

- W_c = Carrier weight and its center of gravity horizontal distance from axis of rotation
- W_u = Upperworks weight, including counterweight and center of gravity location from axis of rotation
- W_b = Boom weight and its center of gravity location from boom king pin
- D_1 = Distance between front and rear outriggers
- D_t = Transverse distance between outriggers
- X_o = Outrigger center of gravity from crane axis of rotation
- t = Distance from boom king pin to crane axis of rotation

Other variables are boom length, radius, and total lifting load (including all rigging weights).

First, to calculate boom and jib center of gravity location L_b horizontal distance from boom king pin:

$$M_b = W_b (t + L_b \cos \theta)$$

$$M_u = \text{Moment of upperworks} = M_b + L (\text{load}) \times R (\text{radius}) - W_u \times d_u (\text{upperworks center of gravity})$$

$$V_u = \text{Vertical loads of upper works} = W_b + L + W_u$$

$$M_{nr} = \text{Moment of all loads about outrigger center of gravity lifting over rear: } M_{nr} = M_u - V_u X_o - W_c d_c$$

$$M_{ns} = \text{Moment of all loads about outrigger center of gravity lifting over side: } M_{ns} = M_u$$

V = Total vertical load = $V_u + W_c$ in addition to moment outriggers must support the vertical load, which is supported equally by each outrigger.

Lifting over rear, outrigger pressure $Pr = V/4 \pm M_{nr}/2d_1$ moment portion is added for the rear outrigger and subtracted for front outrigger.

Lifting over side, $Pfb = V/4 + M_{ns}/2d_t + (W_c d_c + V_u X_o)/2d_1$ boom side front outrig

$Pfc = V/4 - M_{ns}/2d_t + (W_c d_c + V_u X_o)/2d_1$ counterweight side front outrig

$Prb = V/4 + M_{ns}/2d_t - (W_c d_c + V_u X_o)/2d_1$ boom side rear outrigger

$Prc = V/4 - M_{ns}/2d_t - (W_c d_c + V_u X_o)/2d_1$ counterweight side rear outrigger

Moment effect values remain constant for a particular load, operating radius, and boom position relative to longitudinal axis—only the sign changes.

The same condition exists when the boom is positioned over the corner at angle α from the longitudinal axis of crane, operating over the rear. In this case, the value of M_{nr} and M_{ns} will be calculated:

$$M_{nr} = M_u \cos \alpha - V_u X_o - W_c d_c \text{ and } M_{ns} = M_u \sin \alpha$$

M_{nr} is portion of moment due to effect load lift over the rear, and M_{ns} is portion of moment over the side. The individual outrigger pressure is in combination of vertical load and moment.

Lifting over the corner:

$$P_{fb} = V/4 + \frac{(M_{ns}/d_t - M_{nr}/d_l)}{4}$$

$$P_{fc} = V/4 - \frac{(M_{ns}/d_t + M_{nr}/d_l)}{4}$$

$$P_{rb} = V/4 + \frac{(M_{ns}/d_t + M_{nr}/d_l)}{4}$$

$$P_{rc} = V/4 - \frac{(M_{ns}/d_t - M_{nr}/d_l)}{4}$$

It is not unusual for the calculated value for one of the outriggers to be negative. This means that the crane lifts free of an outrigger beam or even lifts a float. In this case, it is considered that the reaction at that outrigger is 0. When two outrigger floats lift or two reactions have negative calculated values, the crane is in the process of tipping. The sum of all outrigger reactions must be equal to total weight of crane + load + boom. In addition, the sum of all moments about crane longitudinal centerline and about transverse line must be 0.

Example:

Find the pressure under the 3900T-SII truck crane outriggers. The crane is equipped with 143 feet of boom #9A with hammerhead top, having 74,000 lb of counterweight, lifting a 50-ton load (inclusive of weight of rigging hardware, load block, main fall) at a 28-foot radius.

$W_b = 23,716$ lb weight of 143 feet of boom

$W_u = 131,490$ lb weight of upperworks including 74,000 lb of counterweight

$d_u = 110.8$ in. = 9.23 ft, center of gravity of upperworks from crane centerline rotation

$W_c = 94,070$ lb weight of lowerworks, including carrier, outriggers, and front bumper

$d_c = 82.1$ in. = 6.84 ft, center of gravity of lowerworks from crane centerline rotation

$t = 43.5$ in. = 3.625 ft, boom king pin from crane centerline rotation

$d_t = 18.73$ ft distance between outriggers and longitudinal center of machine

$d_l = 18.79$ ft distance from front outrigger to crane centerline rotation

$X_o = 2.25$ ft distance from centerline outrigger to centerline crane rotation

$L_b = 68$ ft center of gravity of boom from boom king pin

$M_b = 23.71 (3.625 + 68 \cos 81.7) = 318.7$ k-ft

$M_u = 318.7 + 100 \times 28 - 131.49 \times 9.23 = 1905$ k-ft

$V_u = 131.49 + 100 + 27 = 258.49$ kip $V = 258.49 + 94.07 = 352.56$ kip

$V/4 = 352.56/4 = 88.14$ kip vertical load per outrigger

Example Case 1

Lifting over the rear: boom horizontal angle with crane long. centerline $\alpha = 0$

$$M_{nr} = M_u - V_u X_o - W_c d_c = 1,905 - 258.49 \times 2.25 - 94.07 \times 6.84 = 640 \text{ k-ft}$$

$$P_r = \text{pressure at rear outriggers} = V/4 + M_{nr}/2d_l = 88.14 + 640/2 \times 18.79 = 105.17 \text{ kip}$$

$$P_f = \text{"pressure } \Delta \text{ and front outriggers"} = V/4 - M_{nr}/2d_l = 88.14 - 640/2 \times 18.79 = 71.11 \text{ kip}$$

Example Case 2

Lifting over the corner: boom at 45 degree angle

$$M_{nr} = M_u \cos \alpha - V_u X_o - W_c d_c \text{ and } M_{ns} = M_u \sin \alpha$$

$$M_{nr} = 1905 \times .707 - 581.6 - 643.44 = 122 \text{ kip-ft } M_{ns} = 1,347 \text{ kip-ft}$$

$$P_{rb} = V/4 + _ (M_{ns}/d_t - M_{nr}/d_l) = 88.14 + _ (72 - 6.5) = 120.89 \text{ kip}$$

$$P_{rc} = V/4 - _ (M_{ns}/d_t + M_{nr}/d_l) = 88.14 - _ (72 + 6.5) = 49 \text{ kip}$$

$$P_{rb} = V/4 + _ (M_{ns}/d_t + M_{nr}/d_l) = 88.14 + _ (72 + 6.5) = 127.39 \text{ kip}$$

$$P_{rc} = V/4 - _ (M_{ns}/d_t - M_{nr}/d_l) = 88.14 - _ (72 - 6.5) = 55.40 \text{ kip}$$

$$P_{rc} = V/4 - \frac{1}{2} (M_{ns}/d_t - M_{nr}/d_l) = 88.14 - \frac{1}{2} (72 - 6.5) = 55.40 \text{ kip}$$

Example Case 3

Lifting over side - boom at 90 deg. horizontal. angle from crane long. centerline

$$M_{nr} = 0 \quad M_{ns} = M_u = 1,905 \text{ kip-ft}$$

$$P_{rb} = V/4 + M_{ns}/2d_t + (W_c d_c + V_u X_o)/2d_l = 88.14 + 50.85 + 32.59 = 171.58 \text{ kip}$$

$$P_{rc} = V/4 - M_{ns}/2d_t + (W_c d_c + V_u X_o)/2d_l = 88.14 - 50.85 + 32.59 = 69.88 \text{ kip}$$

$$P_{rb} = V/4 + M_{ns}/2d_t - (W_c d_c + V_u X_o)/2d_l = 88.14 + 50.85 - 32.59 = 106.40 \text{ kip}$$

$$P_{rc} = V/4 - M_{ns}/2d_t - (W_c d_c + V_u X_o)/2d_l = 88.14 - 50.85 - 32.59 = 4.70 \text{ kip}$$

Example Summary

Summarizing the above three lift positions for the truck crane outrigger loads:

Location	P_{rb}	P_{rc}	P_{rb}	P_{rc}
Over rear	105	105	71	71
Over side	171.5	70	106	4.7
Over corner, boom at 45 degrees from rear	121	49	127	55

3900 - T outrigger float is 3 feet square; therefore, the maximum imposed load to the supporting soil is $171/9 = 19 \text{ ksf}$ for the above conditions.

3.9 MATTING

3.9.1 Distribution of Crane Loads to the Supporting Surfaces

The supporting soil (or structure) must be evaluated for the crane reactions that were calculated by the methods in the preceding section. The crane rating given in a load chart is valid and accurate only when the machine operates on a firm, level supporting surface that is structurally sufficient to carry the crane reaction loads. A large number of crane accidents have occurred because of ground support failure. Because site soil conditions vary widely, it is imperative that a competent soil engineer evaluate the soil for the reaction loads imposed by the crane. In many cases, the ground bearing capacity is less than the crane capacity. Therefore, use of cribbing, matting, or steel plate under the crawler or truck crane outriggers is required to distribute the reaction load. This section deals with how to evaluate mats but not soil analysis.

A competent structural engineer is required to determine support adequacy for cranes supported by structures such as foundation mats or floors.

3.9.2 Truck Crane

The mat's bearing area bc is needed to distribute outrigger loading to the supporting surfaces, which can be determined by dividing outriggers force P by soil capacity $s \times bc \cdot P/s$ applied soil pressure under the matting $q = P/bc$. For construction grade timber, the allowable stress is about 1,500 psi and for shear stress, about 125 psi. For checking the timber mat bending moment and applied stresses use:

$$\text{bending moment } M = \frac{1}{2} qba^2$$

$$\text{bending stress } f := \frac{3 qa^2}{d^2}$$

$$\text{horizontal shear stress } v = 1.5qa/d$$

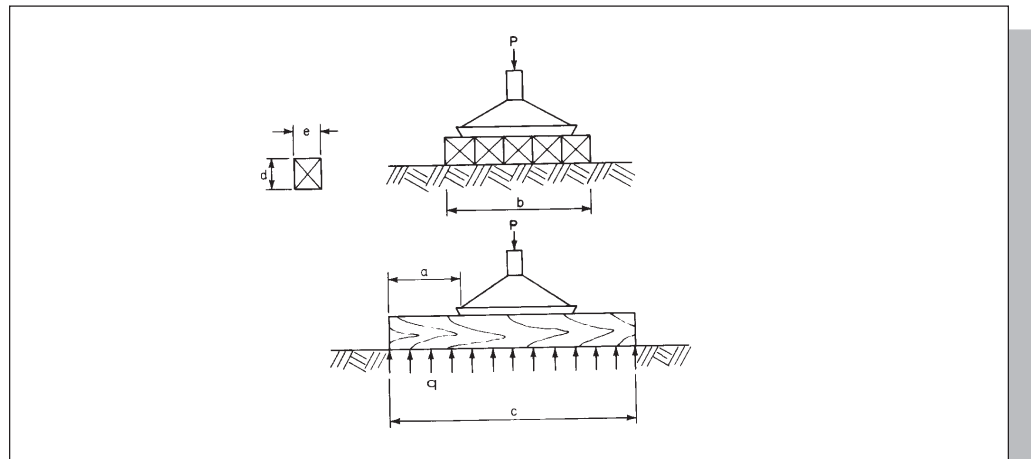

Figure 3.9-1 Outrigger Bearing Area

Example:

3900-T truck crane outrigger force is 171 kip, outrigger float is 3 feet square, and soil bearing capacity is 10 ksf. Design timber mats to support the outrigger load.

Bearing area min. = 171 kip/10 ksf = 17.1 ft² use b = 4 ft and c = 5 ft of 12 in. x 12 in. rough timber mat.

A = (5-3)/2 = 1 ft Applied soil pressure q at bottom of mat = 171 kip/4x5 = 8.55 ksf < 10 ksf size is ok.

$$\text{checking bending stress } f = \left(\frac{3 \cdot 8.55 \cdot 1 \cdot 1}{12 \times 12} \right) = 178 \text{ psi} < 1500 \text{ psi ok}$$

check horiz. Shear $v = 1.5 \times 8.55 \text{ ksf} \times 1 \text{ ft} / 12 \text{ in.} \times (12 \text{ in./ft}) = 89 \text{ psi} < 125 \text{ psi ok}$

Determine the size of steel plate required under outrigger float that can satisfy the soil bearing capacity. Use 4'-3" square steel plate applied pressure under steel plate

$$\begin{aligned} q &= 171 / 4.25 \times 4.25 = 9.46 \text{ ksf, ok} \\ \text{plate thickness } t &= (3qa^2 / f)^{1/2} \\ a &= (4.25 - 3) / 2 = 0.625 \text{ ft.} \\ t &= \left(\frac{3 \cdot 9.46 \cdot 0.625 \cdot 0.625}{24 \text{ ksi}} \right) = 0.68 \text{ in.} \end{aligned}$$

Use steel plate 4 ft. 3 in. square by 5/8 in. thick in lieu of matting for this example.

3.9.3 Crawler Crane

In most cases, matting does not need to be placed under a crawler crane unless the crane is operating on poor soil. Many crawler crane accidents have occurred because of settlement under the crawler and consequently boom failure or tipping. Therefore, to avoid settlement under the crawler and maintain levelness during crane operation, it is a good practice, and in many cases a requirement, to place matting under the crawler crane.

Figure 3.9-2 Crawler Bearing Area Under Crane Mat

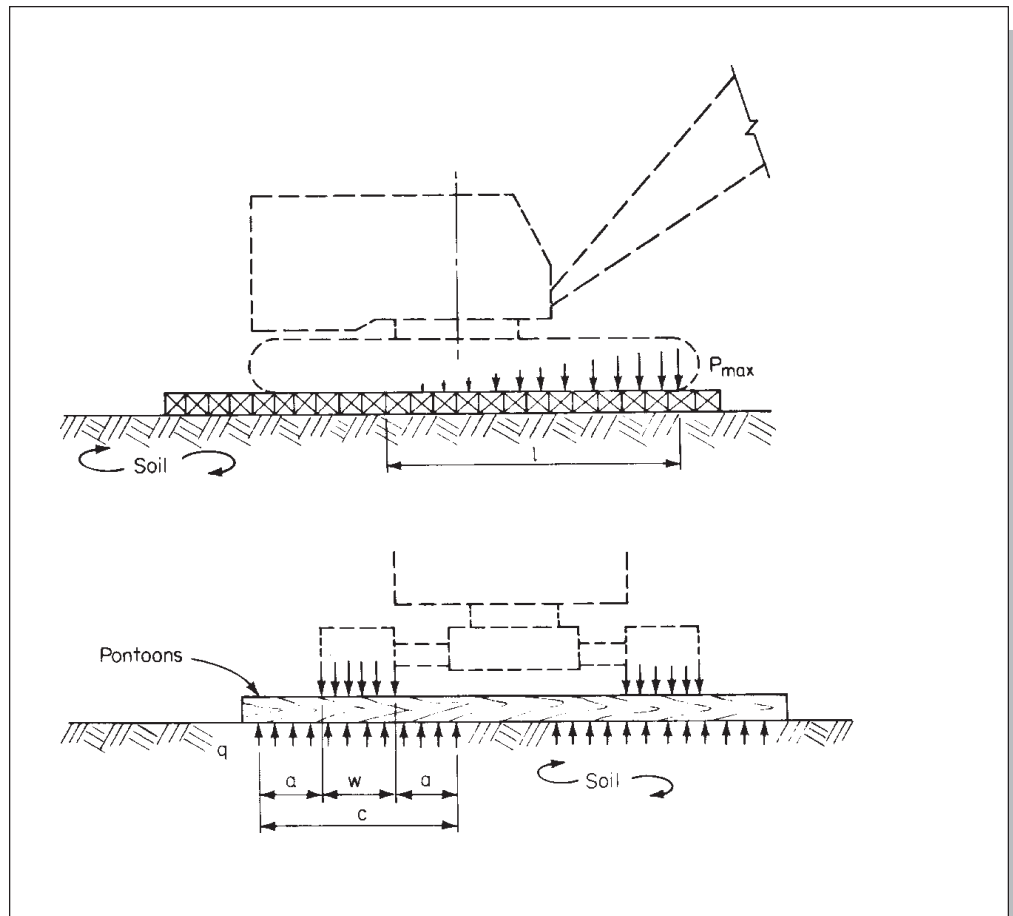
**Example:**

Determine the matting size for a 400W-SII crawler crane lifting over the front

imposing maximum of 10 ksf pressure to the supporting soil, which has 4 ksf soil bearing capacity. The crawler loading pressure diagram is triangular, having 12 feet of effective bearing length.

Rate of pressure at bottom of track is $10 \text{ ksf} / 12 \text{ ft} = 0.83 \text{ ksf}$. Assume each mat consists of four each 12 x 12 rough sawn oak or southern pine connected together by 1 inch diameter steel rods at 4 feet on center. Pressure at one edge of the 4-foot mat is 10 ksf and at the other edge is:

$$10 - 4 \times 0.83 = 6.68 \text{ ksf}$$

The total load on this 4-foot mat is:

$$P = 4 \text{ ft} \times 4 \text{ ft} (10 \text{ ksf} + 6.68 \text{ ksf})/2 = 133.5 \text{ kip}$$

Minimum required soil bearing area = $133.5 \text{ kip} / 4$

$$\text{ksf} = 33.75 \text{ ft}^2$$

$$c = 33.75 / 4 = 8.34 \text{ ft}$$

Consider the crawler tread width as 4 feet, then:

$$a = (8.34 - 4) / 2 = 2.17 \text{ ft}$$

Mat length can be figured by adding c dimension to the dimension B (distance from centerline right track to centerline left track).

$$L = 8.34 \text{ ft} + 17.16 \text{ ft} = 25.5 \text{ ft}$$

Use 26 x 4 foot mats.

Check bending stress:

$$f = 3 \times 4 \text{ ksf} \times 2.17 \times 2.17 / 12 \times 12 = 392.4 \text{ psi} < 1,500 \text{ psi allowable for timber}$$

Check horizontal shear:

$$v = 1.5 \times 4 \text{ ksf} \times 2.17 / (12 \text{ in.}) (12 \text{ in./ft}) = 90 \text{ psi} < 125 \text{ psi allowable 4 x 26 mats ok}$$

3.10 TOWER CRANE SUPPORT AND FOUNDATION REQUIREMENTS

3.10.1 Foundation for Fixed-, Static-Base Tower Cranes

Knowledge of tower crane operation, loading, and wind exposure is necessary to determine the magnitude of the support requirements for a fixed-base tower crane. A specialist should handle all support or mounting configurations. Tower crane manufacturers typically provide foundation reaction information to users. A tower crane is typically erected in place. The jib must be free to weathervane 360 degrees without striking adjacent objects. This also permits full coverage of the work area. A tower crane rigging plan must provide for dismantlement of the crane. Two general loading conditions need to be examined when a tower crane foundation is designed. The first is out-of-service loading and the second is, of course, in-service loading.

3.10.2 Out-of-Service Loads on Tower Cranes

The out-of-service condition typically includes wind loading, both normal and storm; seismic loads; dead load; erection loads; and jacking loads. Torsional loading is generally not a significant factor because the jib is left free to weathervane. Local wind conditions must be examined carefully because most manufacturers design towers for a generic storm wind without regard to regional- or site-specific weather conditions. As tower height increases, a point is reached where out-of-service wind loads may become more critical than the actual in-service loads. Wind velocity increases with tower height. Figure 3.10-1 shows the relationship of height to wind velocity for three different terrains. Exposure A represents large cities and hilly terrain, exposure B illustrates towns and wooded areas, and exposure C represents open country or coastal areas.

3.10.3 In-Service Loads on Tower Cranes

The in-service condition imposes forces from the lifted loads and dead weight. Normal wind and seismic forces must also be accounted for. Because tower cranes must be taken out of service during high winds, storm loading is not generally considered an in-service loading. Storms are somewhat predictable and there is generally time to take the crane out of service. On the other hand, earthquakes are not predictable, and seismic forces should be considered during normal operation. Normal wind loading on the crane during operation is generally worst in the direction perpendicular to the jib because of the high surface area. This wind moment acts perpendicular to the load moment (or backward moment) and the two must be combined vectorially.

Other loadings to consider include slewing inertia and side wind. The slewing motors must be of sufficient capacity to overcome the force of the wind perpendicular to the jib. Slewing loads produce torsional forces in the tower and the foundation.

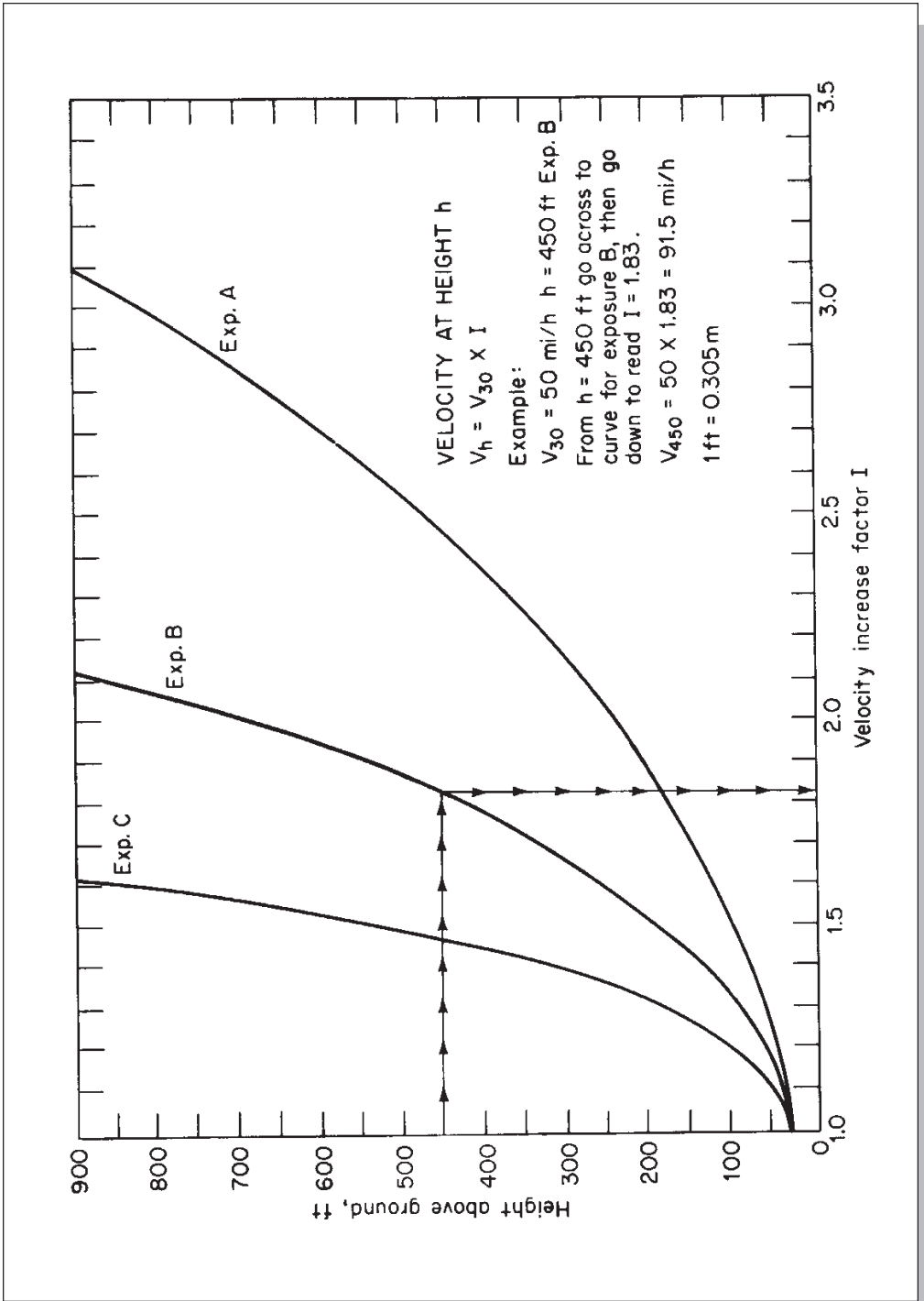

Figure 3.10-1 Wind Velocity Versus Height

3.10.4 Soil Pressure Considerations and Example Problems

The following examples are based on problems found in *Cranes and Derricks* by the leading tower crane authority, Howard Shapiro. Every Bechtel engineer involved with cranes and rigging should obtain a copy of this book as a reference (available from McGraw-Hill publishers).

Example:

Wind velocity at 450 ft height = wind velocity at ground 50 m/h x 1.83 = 91 m/h for exposure B.

For the static-mounted crane, the foundation is a mass of concrete that provides ballast to resist overturning and provides safety factors. The concrete foundation must support dead weight, vertical load, shear forces due to wind, and torsion due to slewing. Shear forces are small and normally do not govern. Shear connection between the mast and support base should be properly designed.

For stability requirements, the tower crane's base moment must resist 1.33 to 1.5 times of the applied overturning moment.

M1 = Applied moment at the base

M2 = Resisting moment at base

$$1.50 M1 = M2 = \frac{(P + W) B}{2}$$

P = Vertical load

W = Weight of base concrete

B = Width of square footing

$$B = \frac{3M1}{P + W} \quad \text{Unit weight of concrete is 150 pcf.}$$

Considering the V = horizontal shear the footing stability will be when

$$1.5(m1 + Vd) \leq PB/2 + wdB^3 \quad d \geq \frac{3 M1 - PB}{wB^3 - 3 V} \quad \text{depth d should be about B/6 minimum.}$$

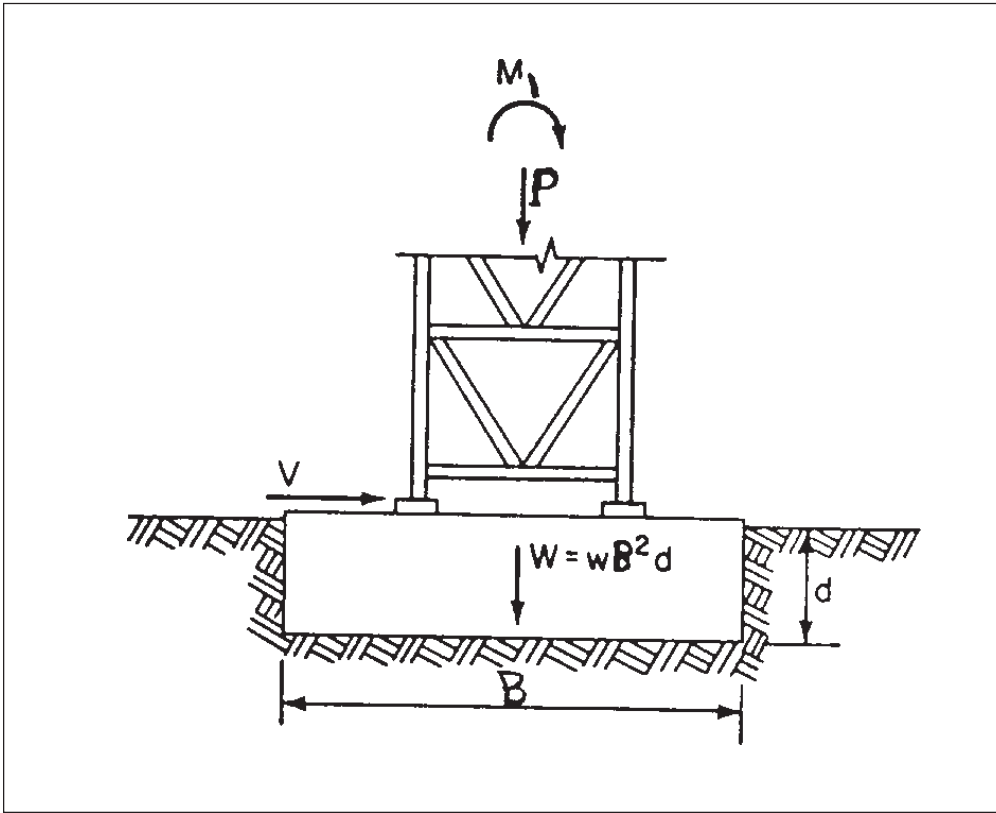

Figure 3.10-2 Tower Crane Footing

Imposed pressure on the soil by the footing is the combined moment plus the vertical load.

$$\text{Vertical load } v := \frac{W + P}{B \cdot B} = \frac{wB^2 d + P}{B^2} = wd + \frac{P}{B^2}$$

$$\text{using beam analogy } f = \frac{(M_1 + vd) \frac{B}{2}}{\frac{B^4}{12}} = \frac{6(M_1 + Vd)}{B^3}$$

Resultant pressure under footing is trapezoidal and max. pressure under footing $P_{\max} = v + f$ when the $v > f$ free standing tower crane Foundation.

When the vertical load $v \leq f$ the loading pattern under footing will be triangular. $T =$ length of

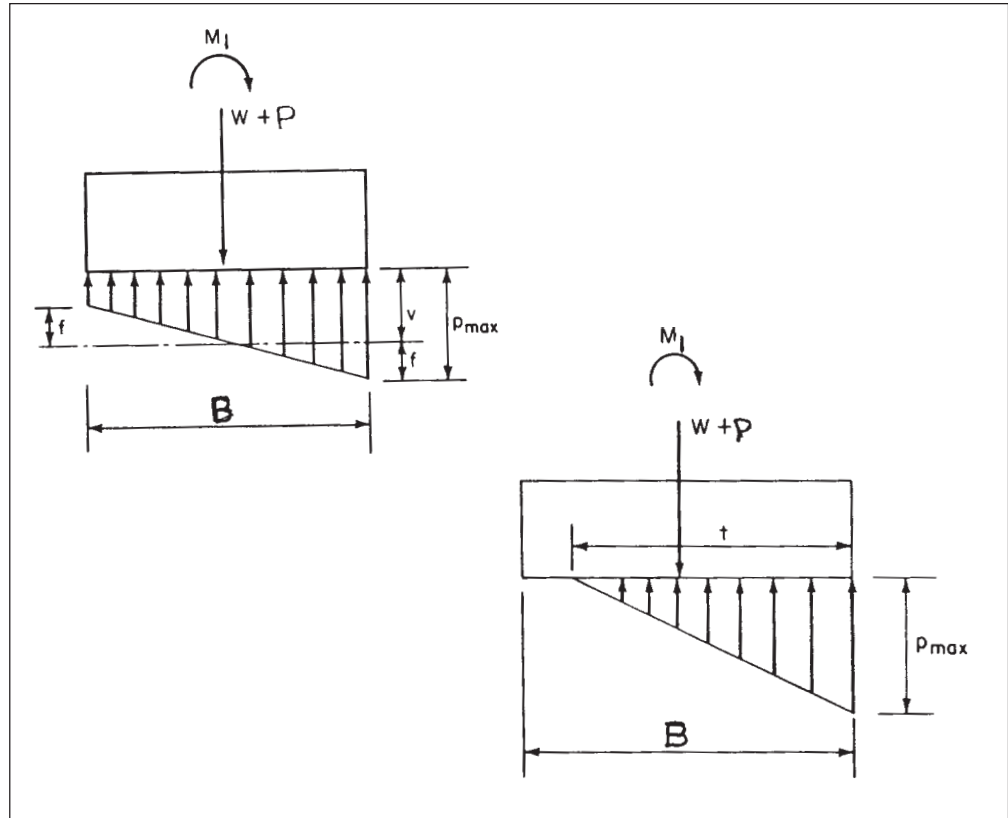

the triangle.

Figure 3.10-3 Tower Crane Footing Load Distribution

Applied and resisting vertical load expression:

$$W + P = p_{\max} \text{ pressure under footing} \times Bt/2$$

The expression for applied and resisting moments in equilibrium:

$$M_1 + Vd = (W + P) (B/2 - t/3)$$

$$t = 1.5B - \frac{3(M_1 + Vd)}{W + P} = 1.5B - \frac{3(M_1 + Vd)}{vB^2} p_{\max} = 2(W+P)/Bt = 2 vB/t$$

For calculating maximum soil pressure at the footing corner due to wind on diagonal use:

$$p_{\max} \text{ diag.} = \frac{\left(\frac{v}{2}\right) \left[\frac{B}{(A\sqrt{2}) - 1}\right]}{\left(\frac{B}{3A\sqrt{2}}\right) + \left[\frac{2A}{B} \left(1\sqrt{2} - \frac{A}{3B}\right)\right] - 1} A = \frac{M_1 + Vd}{W + P} = \frac{M_1 + Vd}{vB^2}$$

3.10.5 Soil Bearing Capacity Data

Table 3.10-1 shows the soil bearing capacity and related data for various type of soil.

Table 3.10-1 Typical Soil Capabilities

Soil type	Density or state	Approx. unit weight, lb/ft ³	Presumptive bearing capacity, tons/ft ²		Angle of internal friction, degrees
			Typical building code	For cranes	
Rock (not shale unless hard)	Bedrock		60	60	
	Layered		15	15	
	Soft		8	8	
Hardpan, cemented sand or gravel			10	10	
Gravel, sand and gravel	Compact	140	6	8	45
	Firm	120		6	40
	Loose	90	4	4	34
Sand, coarse to medium	Compact	130	4	6	42
	Firm	110		4.5	38
	Loose	90	3	3	34
Sand, fine, silty, or with trace of clay	Compact	130	3	4	34
	Firm	100		3	30
	Loose	85	2	2	28
Silt	Compact	135		3	30
	Firm	110		2.5	28
	Loose	85		2	26
Clay	Compact	130	3	4	30
	Medium	120	2	2.5	20
	Soft	90	1	1	10

† 1 lb/ft³ = 16.018 kg/m³; 1 ton/ft² = 95.76 kPa.

Example:

Design a footing for a tower crane weighing 100 tons that will be subjected of 3,000 k-ft across the mast and 4,000 k-ft on the diagonal. The wind shear is 20 k and 20 k respectively. Soil bearing capacity is 8 k/ft².

Component of diagonal wind that acts cross the side = 4,000 x cos 45 = 2,828 k, then the 3,000 k-ft moment cross the mast. Assume width of footing = 110' weight:

$$B = \frac{3M_1}{P+W} = \frac{3 \times 3000}{200k + 220k} = 21.4 \text{ ft use } 22 \text{ ft}$$

$$\text{depth } d = \frac{3(3000) - 200(22)}{.15(22 \times 22 \times 22) - 3(15)} = 3 \text{ ft use } 3 \text{ ft } 6 \text{ in.}$$

Footing size is 22 ft x 22 ft x 3.5 ft

$$\text{Soil pressure, } v = 0.15 \times 3.5 + 200/22 \times 22 = 0.95 \text{ k/ft}^2$$

$$\text{Footing side overturning moment, } M_1 + V_d = 3,000 + 15 \times 3.5 = 3,052.5$$

$$\text{Moment contribution to the ground pressure, } f = 6(3,052.5)/22 \times 22 \times 2$$

Because $f > v$, the soil pressure pattern will be triangular.

$$\text{with length of } t = 1.5 \times 22 - \frac{3 \times 3052.5}{.95 \times 22 \times 22} = 13 \text{ ft}$$

$$\text{Maximum soil pressure from side moment } \rho = 2 \times 0.95 \times 22/13 = 3.23 \text{ k/ft}^2$$

$$\text{Check diagonal pressure: } A = \frac{4000 + 22(3.5)}{0.95 \times 22 \times 22} = 8.8 \text{ ft}$$

$$\text{Max. diag. pressure } \rho = \frac{0.95/2(22/8.8\sqrt{2}-1)}{22/3(8.8\sqrt{2}+2(8.8)/22[1/\sqrt{2}-8.8/3(22)]-1} = 7.5 \text{ k/ft}^2$$

This value is more than the over-side pressure but less than soil bearing capacity.

3.10.6 Anchorage of Tower Base

The tower base must be anchored to the footing so that the vertical load, moment, and shear can be transferred to the footing. Using square mast, having L as a distance between mast leg and diagonal distance will be:

$$s = L \times \sqrt{2}$$

The force on the legs effected by the moment applied diagonally will be:

$$F_{\text{diag}} = -\frac{Q}{4} \pm \frac{M_0}{s\sqrt{2}} \text{ (minus sign represents compressive force).}$$

For moment applied over side (parallel) to the mast side, the legs will carry

$$F_{\text{par}} = -\frac{Q}{4} \pm \frac{M_0}{2s}$$

The diagonal leg load is higher than the side leg loads, both in tension and compression. The compressive load is higher than tensile and will govern the anchor design. The anchor design should have anchor bolts capable of transmitting not less than 1.5 M to the concrete footing. To support the uplift (tensile) load, anchor bolt ends should be connected to a baseplate that is embedded in the middle of the footing. Figure 3.10-4 shows the projected area at the footing surface for a square anchor baseplate of width (w) and embedded at depth (d_0). Consider the diagonal tension from each edge of the buried plate applied at 45 degrees:

Area for each leg at footing surface:

$$A = (\rho + 2d_0)^2 - \rho^2 = 4d_0(\rho + d_0)$$

The tensile stress on the area:

$$\sigma_t = \frac{F_{diag}^+}{A} = \frac{1/4[-(Q/4) + 1.5 M_0/s\sqrt{2}]}{\rho d_0 + d_0^2}$$

For minimum depth d_0 for the anchor base in the concrete footing which would satisfy the load and the concrete, use:

$$d_0 = \frac{1}{2} \left[\left(\frac{\rho^2 + F_{diag}^+}{\sigma_a} \right)^{1/2} \right]$$

For leg in compression, considering (d) the depth from buried anchor plate to the bottom of the footing; limiting value of concrete is (working stress):

$$\sigma_a \geq \frac{-F_{diag}}{A} \geq \frac{1/4[(Q/4) + M_0/s\sqrt{2}]}{\rho d + d^2}$$

And required min. depth (d) for compression leg:

$$d = \frac{1}{2} \left[\left(\frac{-F_{diag}}{\sigma_a} \right)^{1/2} \right]$$

$$\sigma_a = 2\sqrt{f'_c}$$

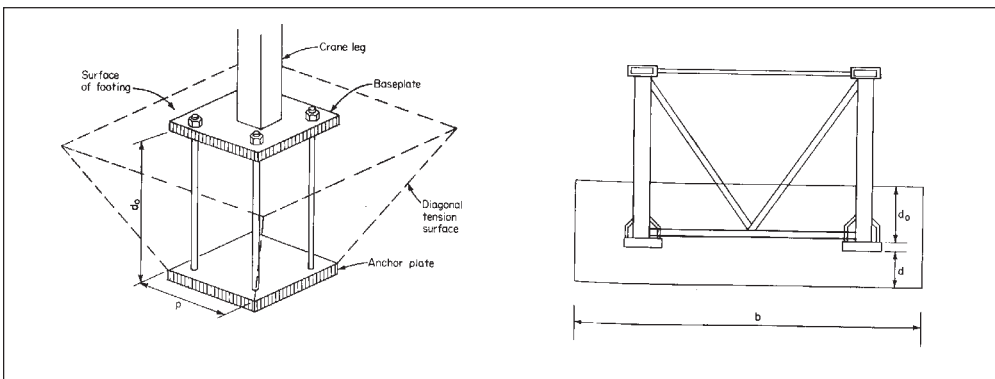

Figure 3.10-4 Tower Crane Foundation Anchor Detail

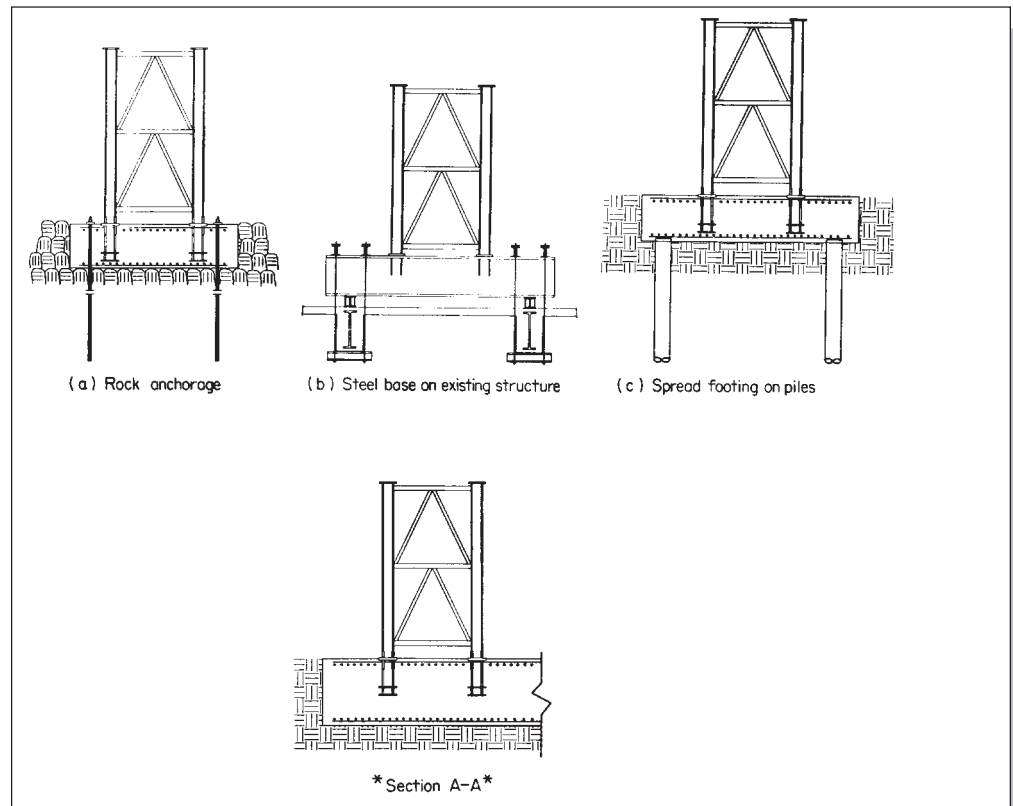

Figure 3.10-5 Typical Tower Crane Anchor Schemes

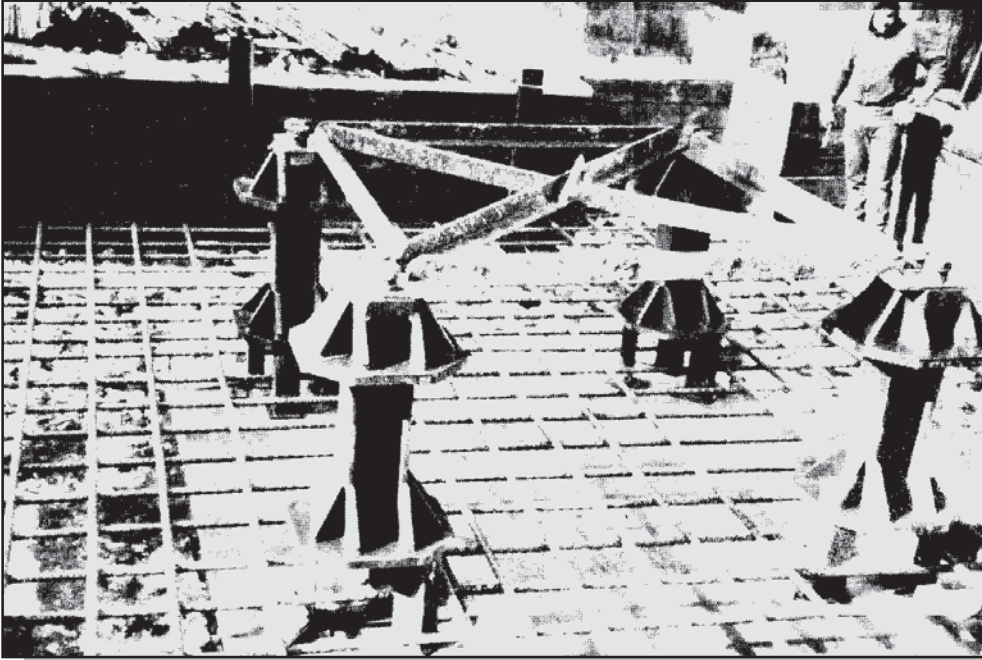

Figure 3.10-6 Typical Tower Crane Foundation Embedded Anchorage

Example:

Determine the anchor depth for a tower crane mast legs 8 feet apart having a 2-foot square anchor plate. Crane weight is 200 kips; moment cross the mast is 3,000 k-ft and 4,000 k-ft for diagonal. The wind shear forces are 15 and 20 kips respectively. For concrete strength use 4,000 psi.

$$\text{Uplift or tension in the mast leg: } F_{\text{diag}} = -200/4 + \frac{1.5(40000)}{8\sqrt{2}} = 481 \text{ kip}$$

$$\text{Allowable (limiting) concrete strength: } F_{\text{diag}}/A = 2\sqrt{f'_c} = 126.5 \text{ psi}$$

$$\text{Minimum depth for uplift resistance } d_0 = \frac{1}{2} \left[\left(24^2 + \frac{481000}{126.5} \right)^{1/2} - 24 \right] = 21 \text{ in.}$$

$$\text{Minimum depth required for compression } F_{\text{diag}} = -200/4 - 4000/8\sqrt{2} = -404 \text{ kip } d =$$

$$\frac{1}{2} \left[\left(24^2 + \frac{484000}{126.5} \right)^{1/2} - 24 \right] = 22.5 \text{ in.}$$

$$\text{Total depth of footing} = d_0 + d = 43.5 \text{ inches.}$$

3.11 CRANE SAFETY AND SELECTION

When a crane is selected, the boom configuration, the weight of the load, and the radius at which the load is to be handled must all be known. To determine the appropriate boom configuration or working radius, several factors must be considered. One must establish how high the load must be raised, how much clearance must be maintained between the boom and the load, and how far away from the load the crane must stand. To accurately estimate the boom and radius requirements, a plan view drawing of the work area is required. The load lifting area, the load placement area, and the crane setup area are the specific jobsite areas that are the basis of a lift planning. A lift should never be planned that exceeds the published crane capacity. Because the calculated weight of load is approximate, a 5 percent margin of error should be considered. A plan and elevation view drawing is most useful.

Terms such as rating chart, load chart, load rating chart, maximum allowable capacity chart, lift chart, and ratings all mean the same thing and are crane-manufacturer-supplied documents. They list the maximum gross loads for various radii and boom lengths for the crane being operated properly. Manufacturers list a number of specific conditions that must be met to make the ratings valid. Therefore, the safe and proper use of the crane is dictated by the rating chart. Misuse of the crane rating chart can create a serious problem. One should never consider operating in the “tipping portion” (the part of the rating chart where the maximum load/radius combination is determined by the stability of the crane). Some derating factors are the crane not being level, high winds, operation on a barge, personnel handling (use of personnel basket), and extreme cold.

Many countries require that a crane be inspected. If so, it is either done daily, monthly, or annually. The operator performs the daily inspection. The supplier performs the monthly inspection and an inspection report is maintained as part of the crane document. A reputable and licensed independent agency needs to complete an annual inspection. Comprehensive annual inspection records form the basis for verifying the condition of the machine. One must use the U.S. Department of Labor booklet “Mobile Crane Inspection Guidelines for OSHA Compliance Officer.”

The following devices provide aid to crane operators:

- Boom angle indicator—Sensed and electronically displayed in the cab.
- Drum turning indicator
- Empty or overfill drum indicator—Sensing device warning the operator
- Over hoisting indicator—Sensing device warning the operator of getting too near blocking
- Over hoisting limiter—Anti-too blocking device
- Over booming limiter—Device that shuts down power when the boom reaches its maximum angle limit
- Load indicator device—Sensing device that measures the weight of the load (The load is typically sensed by measuring the tension as the hoist line is threaded through a series of sheaves or at the dead end of the hoist line. The second type of load indicator device is known as dynamometer and is attached directly to the hook, giving a direct readout of load on the hook.)
- Load moment indicator—Electronic system that senses the overturning moment on the crane or weight on the hook and radius. The load and radius are electronically displayed to the operator. In addition, the system electronically compares the actual values of load and radius with the crane capacity chart stored in the system. An indication of the percentage of rated capacity at which the crane is working is displayed to the operator.
- Rated capacity limiter—Device that will shut down power when overload is reached.

4

RIGGING COMPONENTS



4. Rigging Components

4.1 SLINGS AND HITCHES

A wire rope sling is defined as the wire rope assembly that connects the load to the lifting device. A hitch is the manner of using the sling to support the load. See Figure 4.1-1.

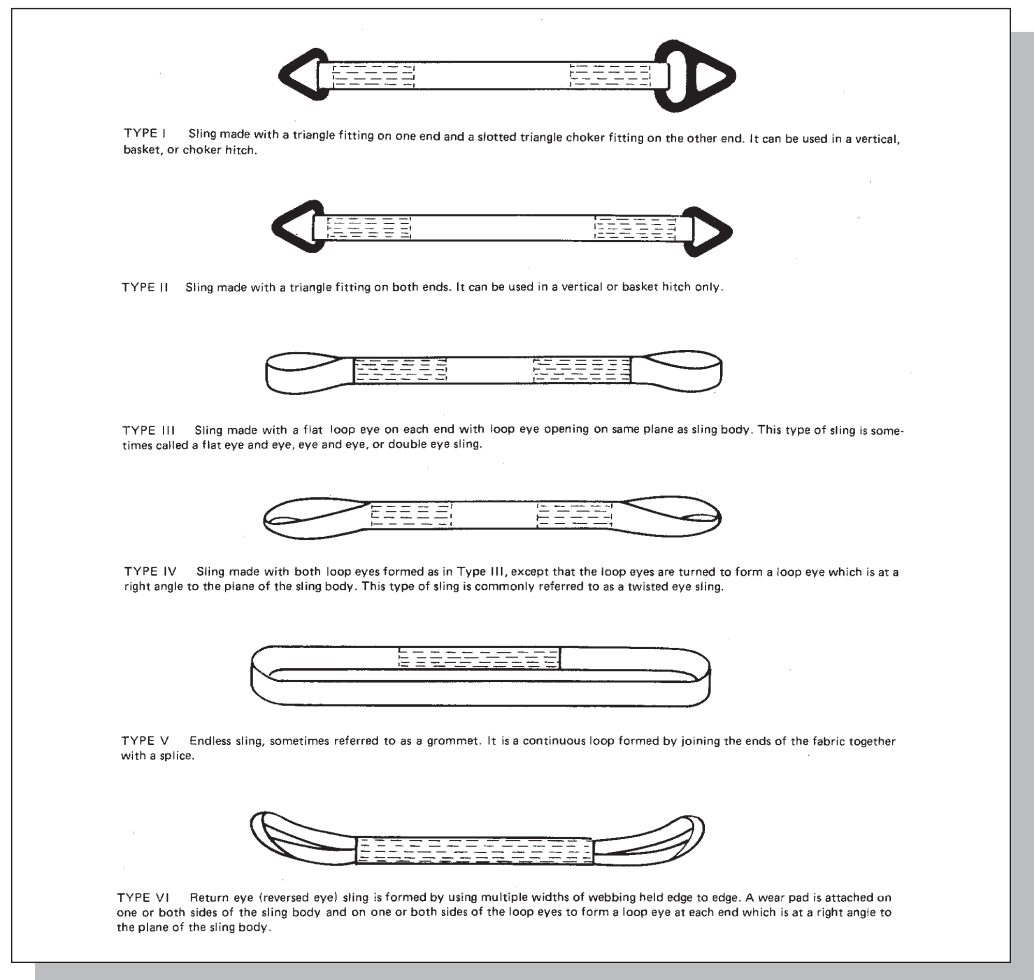

Figure 4.1-1 Synthetic Webbing Sling Types

4.1.1 Suspended Load

Irrespective of the number of slings, the type of hitches used, or the use of spreader bars, the center of gravity of a suspended load always lies directly beneath the point of attachment to the lifting device (crane hook). Slings and hitches must be chosen properly to achieve the desired orientation of the hanging load (for example, level orientation), the desired stability, and desired rope factor of safety.

4.1.2 Single Vertical Hitch

The single vertical hitch is also called a direct connection hitch. When used singly, it does not afford the best load control or protection against spin. It is effective when used in multiples with spreader bars or when two or more attachment points are provided on the load.

4.1.3 Basket Hitch

Basket hitches are used singly only to raise one end of a load and usually wed in pairs on symmetrical loads. Do not lift smooth, cylindrical objects with sling legs at flat angles unless projections or other positive means will prevent sling movement. Rope in this hitch can roll along a smooth surface, as well as slide. Cylindrical loads supported by basket hitches around the bottom must remain level. A pair of double wrap basket hitches compresses a bundle load and provides more resistance to slipping.

4.1.4 Reverse Basket Hitch and Single Length Double Basket Hitch

In these hitches, the bight of the sling bears on the crane hook. The sling is free to move over the hook according to the weight distribution and automatic equalization takes place. **For this reason, these hitches must be used with caution.**

See Figure 4.1-2 for various forms of vertical, choker, and basket hitches.

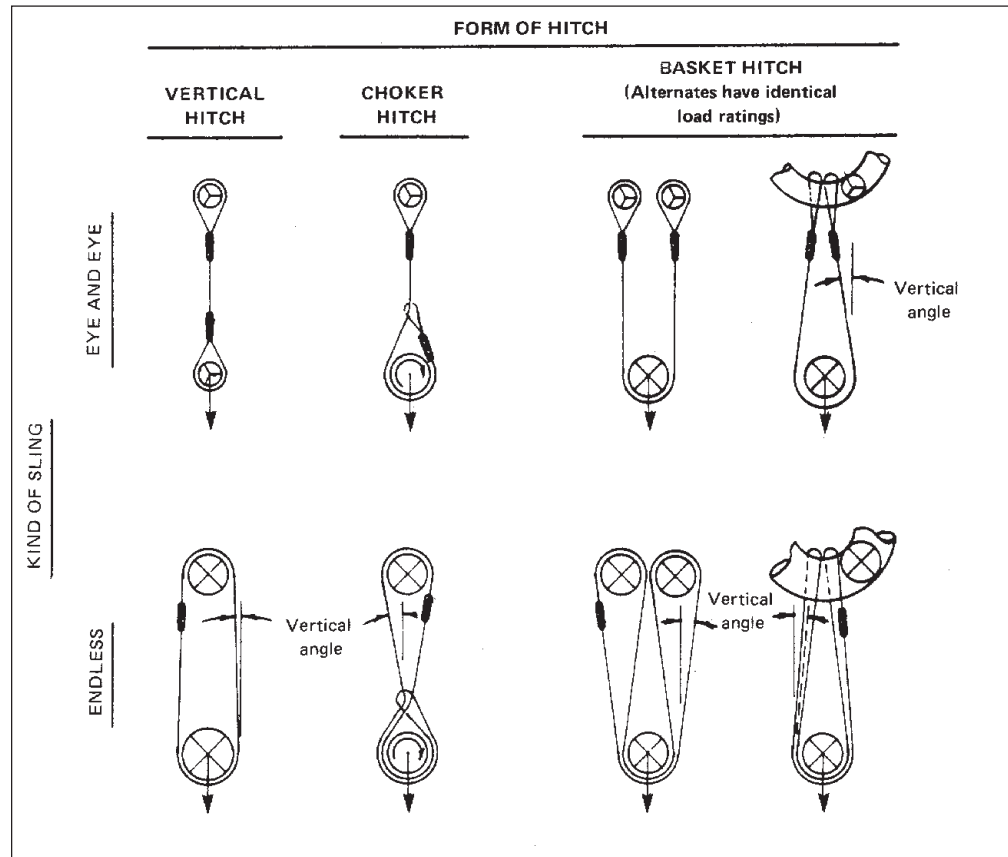

Figure 4.1-2 Basic Vertical Rope Sling Configurations

The following symbols represent load or support surfaces:



Represents a contact surface that must have a diameter of curvature at least double the diameter of the rope from which the sling is made.



Represents a contact surface that must have a diameter of curvature at least eight times the diameter of the rope.



Represents a load in choker hitch and illustrates the rotary force on the load and/or the slippage of the rope in contact with the load. Diameter of curvature of load surfaces must be at least double the diameter of the rope.

The following symbols represent load or support surfaces:

Legs 5 degrees or less from vertical may be considered vertical. Legs more than 5 degrees off vertical must use actual angle shown in Figure 4.1-3.

		FORM OF HITCH		
		VERTICAL HITCH	CHOKER HITCH	BASKET HITCH (Alternates have identical load ratings)
KIND OF SLING	EYE AND EYE	NOT APPLICABLE	NOT APPLICABLE	
	ENDLESS	NOT APPLICABLE	NOT APPLICABLE	

Figure 4.1-3 Rope Sling Configurations with Angled Legs

4.1.5 Basket Hitch Uses

Acceptable

- Basket hitches may be used to lift loads having lifting lugs or trunnions located above the center of gravity of the load.
- Basket hitches may be used to equalize loads in a pair of legs of a four-leg sling arrangement by using two equal slings and one long sling with its bight over the hook.

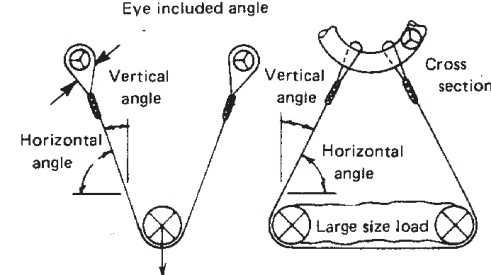
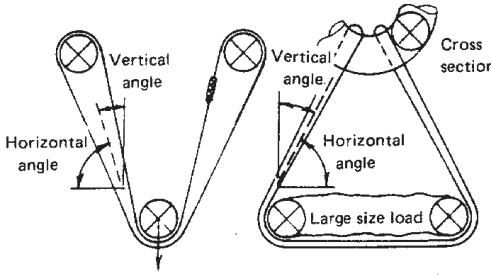
Unacceptable

- Basket hitches may not be used to lift an unsymmetrical load with a center of gravity significantly closer to one picking point than the other.

4.1.6 Choker Hitch

A single choker hitch, or noose, does not provide full contact with the load and should not be used to lift loose bundles or long loads. A doubled choker hitch, consisting of two single chokers, can be spread to provide load stability. Double-wrapped choker hitches compress the load and prevent it from slipping out of the sling.

A doubled choker hitch provides twice the capacity and a degree of stability useful in turning loads. The bight should lay over the hook for equalization. Turning should be done in the direction opposite to the direction that the eyes point.

4.1.7 Wire Rope Sling Configurations

- **Single leg bridle or sling**—A single leg bridle or sling is the most common type of sling with a loop at each end and optional thimbles, links, or hooks. These slings are sometimes referred to as chokers. The nomenclature is sometimes confusing because the slings can be used in a vertical hitch, basket hitch, or choker hitch. Conversely, other types of slings can be used in a choker hitch.
- **Multiple leg bridle**—The multiple leg bridle consists of two or more legs attached to a link for convenient handling and assembly.
- **Endless sling**—Endless slings may be mechanically spliced or laid up endlessly in a helical manner so that a loop of six parts and a core is formed. The latter is also correctly called a grommet. Be wary of endless slings used in basket hitches because if the center of gravity of the load is high, the sling can rend over the hook. These slings are most often used in a doubled choker or anchor hitch.

4.1.8 Wire Rope Sling Body Construction

- **Single-part sling**—A single-part sling is the most common sling construction. It consists of a single leg sling made from a length of wire rope or a grommet sling made from a continuous length of strand to form an endless rope. This is the stiffest type of sling construction, and most abrasion resistant. This construction, in form of a grommet, is called strand-laid.
- **Multi-part cable-laid sling**—A cable-laid sling is composed of six individual wire ropes laid helically around a wire rope core. It is much more flexible and less abrasion resistant than the single-part sling. Grommet slings are available in this configuration.
- **Braided sling**—A braided sling may be machine- or hand-braided using four, six, or eight parts of wire rope. This is the most flexible and most expensive construction.

4.1.9 Wire Rope Cores

The core of a wire rope provides uniform spacing of the strands and thus uniform distribution of the load over the individual strands. In fact, the function of the core is to support the strands of rope under load so that they will not press against each other. This can only be achieved if the core is sufficiently thick. In the unloaded rope, the core should be visible between the strands. If the core is too thin, the strands lie (hard-up) against each other in the unloaded rope. Under load and bending, the rope is compressed by the inward forces exerted by the strands, and the strands will wear each other out, resulting in premature wire breakage. A rope may have a fiber core or a steel core. A steel core may consist of a complete wire rope of its own (known as independent wire rope core) or of a wire strand (known as wire strand core).

See Figure 4.1-4.

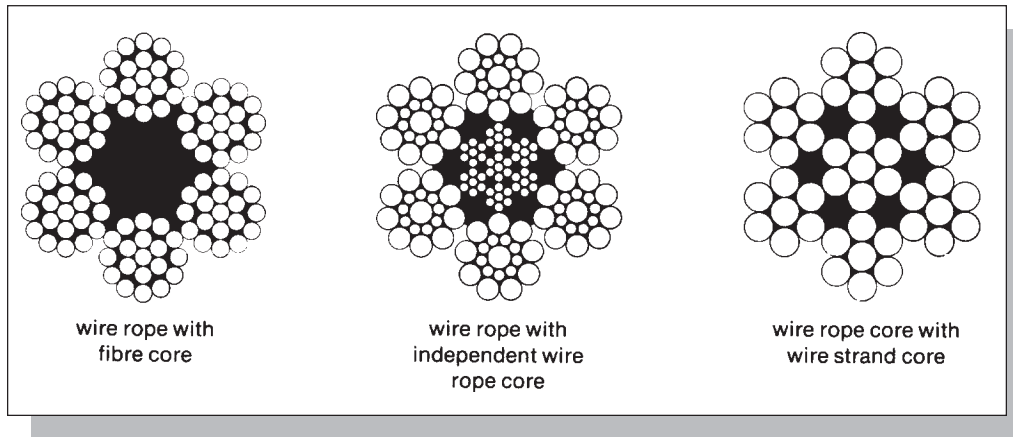

Figure 4.1-4 Wire Rope Cores

There is a considerable difference of opinion about the properties of fiber cores. In addition, it is becoming apparent that fiber cores do not give satisfactory performances under all circumstances. Favorable properties of fiber cores are:

- The wire strands easily move relative to the fiber core on bending without damage or wear of the individual wires.
- No core wires cross the wires of the strands.

The following properties of fiber cores, which originally were considered as advantageous, have actually been proven to be disadvantageous:

- The compressibility of the fiber core enables the rope to smoothly absorb and brake off shock loads. The fiber core increases the elasticity of the rope. However, this only applies to a new rope. After having been used for some time, the fiber core gets thinner and the strands come to lie against each other. When the rope is bent, the strands slide along each other and wear each other out. This wear cannot be seen from

the outside and, therefore, constitutes a great hazard. In addition, the high elasticity of the rope is lost as soon as the strands lie against each other.

- The fiber core provides permanent lubrication from inside. This again applies only to a new rope because the fiber core is “drained” by compression (i.e., the grease is squeezed out of the core). As soon as the grease has been removed from the core, the dry fibers absorb moisture and internal corrosion sets in. This effect may be reduced by proper lubrication during use, but this is not sufficient because the lubricant cannot penetrate to the heart of the fiber core.
- A wire rope with fiber core would be much more flexible than a rope with a steel core and could therefore be used on smaller sheaves and drums. A new rope with a fiber core may be somewhat more flexible than a rope with a steel core, but this flexibility is not related to higher endurance with regard to bending life fatigue. Next to that, the flexibility is very soon lost during operation. Moreover, because a rope used on small sheaves or drums is more susceptible to wear and deterioration, a rope with a steel core will last much longer under these circumstances.

The following properties of fiber cores have always been considered as disadvantageous:

- A rope with fiber core is susceptible to deterioration.
- When the rope is exposed to high temperatures, the fiber core will soon age and waste away. It becomes too thin and one of the strands will pull in so that the balance between the strands is upset—known as the corkscrew effect. The irregular distribution of the load over the strands will result in early failure of the rope.
- In other cases where the fiber core is subject to serious wear or wasting away, the load is no longer uniformly distributed over the strands.

4.1.10 Wire Rope Sling Length

- **Single or multiple leg**—Length is measured from bearing point to bearing point of loops or hooks with no load on the sling. The minimum clear length between sleeves of mechanical splices is 10 rope diameters. Length tolerance is plus or minus two rope diameters, or plus or minus 0.5 percent of the length, whichever is greater. The length of matched slings are held to within one rope diameter of each other.
- **Endless slings**—Length is measured inside the circumference. Tolerance for an endless sling is six body diameters, or plus or minus 1 percent of the length, whichever is greater.

4.1.11 Wire Rope Sling Strength

- **Wire rope strength**—The published breaking strength is the starting point for determining the safe working load of a wire rope sling. OSHA requires that in a sling application, the safe working load of the rope is 20 percent of its breaking strength.
- **End connection efficiency**—The appropriate (80 to 100 percent) end connection efficiency obtained from data in Section 3 must be applied to the rope’s safe working load, which is calculated above.

- **Nominal fabrication factor**—If the sling is endless, a fabrication factor for hand tucked splices or splice efficiency for mechanical splices is applied in lieu of the end connection efficiency.
- **Bending stress efficiency bending over round objects**—The D/d ratio is determined. If the bend strength efficiency is less than the end connection or fabrication efficiency, the bend strength efficiency is applied to the wire rope's safe working load, instead of applying the end connection efficiency or nominal fabrication factor.
- **Bending at choker hitch**—Customarily, the efficiency of a vertical choker hitch has been assumed to be 75 percent of the loss, in addition to end connection efficiency loss. Test results indicate that this may not always be conservative. Tests were performed on single part slings without choker hooks or other softening at the point of choke. When the load is freely suspended, the center of gravity is directly under the point of choke and 135 degrees is about the minimum angle one will observe. Smaller angles occur when other supporting forces are acting on the load in addition to the choker sling. Some examples are:
 - Choker hitch used in turning a load—The additional supporting force is ground reaction or a second crane hook.
 - Choker hitch tailing a column when point of choke is not directly over the centerline of the vessel—The additional supporting force is a second crane lifting trunnions in a manner that holds the axis of trunnions level.
 - Two choker hitches supporting a load when the points of choke are not located identically in relation to the load—Chokers are each tending to rotate the load, but in opposite direction.

These and similar situations call for sling capacity in excess of the 75-percent formula and in accordance with Table 4.1-1.

Table 4.1-1 Percentage of Choker Rated Load

Angle of Choke (Degrees)	Sling Rated Load (Percentage of Choker Rated Load)
120-180	100
90-119	87
60-89	74
30-59	62
0-29	49

NOTE: This factor is applied to the wire rope breaking strength in a vertical pull. Refer to Figure 4.1-5 for definition of angle of choke.



STEEL SLINGS

Steel slings excel in lifting situations involving abrasion, heat, sharp edges and low headroom

PERMALOC WIRE ROPE SLINGS

These slings are a good choice for general purpose lifting in environments too rugged for synthetic slings.

- Extra improved plow is standard
- Special assemblies available
- Every sling identification tagged

SINGLE LEG



ROPE DIA. (IN.)	LOOP SIZE (INCHES) W X L	EIP IWRC ROPE SLINGS RATED CAPACITIES (TONS)		
		VERT.	CHOKER	BASKET*
1/4	2 x 4	.65	.48	1.3
5/16	2 1/2 x 5	1.0	.74	2.0
3/8	3 x 6	1.4	1.1	2.9
7/16	3 1/2 x 7	1.9	1.4	3.9
1/2	4 x 8	2.5	1.9	5.1
5/8	4 1/2 x 9	3.2	2.4	6.4
3/4	5 x 10	3.9	2.9	7.8
7/8	6 x 12	5.6	4.1	11.0
1	7 x 14	7.6	5.6	15.0
1 1/8	8 x 16	9.8	7.2	20.0
1 1/4	9 x 18	12.0	9.1	24.0
1 1/2	10 x 20	15.0	11.0	30.0
1 3/4	11 x 22	18.0	13.0	36.0
1 7/8	12 x 24	21.0	16.0	42.0
2	14 x 28	28.0	21.0	57.0
2 1/4	16 x 32	37.0	24.0	64.0

*Basket hitch values apply when load diameter is 40 times greater than rope diameter and legs are vertical.

ADJUST-A-LINK

The Adjustable Alloy Chain Sling

The most easily adjustable and versatile chain sling available. Don't waste your time searching for a sling of just the right length. Do it quickly and do it right with Adjust-A-Link.



LIFTALLOY 800 WELDED CHAIN SLINGS

Alloy chain slings are the most durable slings available.

- Every assembly proof tested
- The security of tamper-proof welded slings
- Fast service
- New and repaired slings
- Inspection & certification service

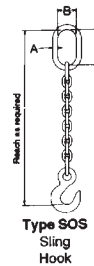

Type SOS Sling Hook

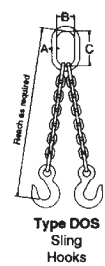

Type DOS Sling Hooks

Rated Capacities (Lbs.)

Chain Dia. (In.)	Single chain slings type S & C		Double chain slings type D	
	SIZE	SINGLE @ 90°	DBL. @ 60°	
7/32		2,100 lbs.	3,600 lbs.	
9/32		3,500 lbs.	6,100 lbs.	
3/8		7,100 lbs.	12,300 lbs.	
1/2		12,000 lbs.	20,800 lbs.	
5/8		18,100 lbs.	31,300 lbs.	
3/4		28,300 lbs.	49,000 lbs.	
7/8		34,200 lbs.	59,200 lbs.	
1		47,700 lbs.	82,600 lbs.	
1 1/4		72,300 lbs.	125,200 lbs.	

U.S. Pat No. 4,941,698

Chain Dia. (In.)	Rated Capacities (Lbs.)	
	Single @ 90°	DbL. @ 60°
□ 7/32	2,100	3,600
□ 9/32	3,500	6,100
□ 3/8	7,100	12,300
□ 1/2	12,000	20,800



Figure 4.1-5 Choker Hitch Efficiency Factors

Choker hooks prolong sling life and undoubtedly reduce bending stresses in the wire at the point of choke.

The use of a ring softener that is free to rotate at the point of choke changes the problem completely. If a shackle, complete with ring softener, with D/d of 4 or more is used at the point of choke, a condition exists where bending stress analysis is more appropriate than the tabulated factors. Contact a certified rigging engineer for guidance on this type of application when it is desired to minimize the sling size on a particular lift. See Figure 4.1-6.

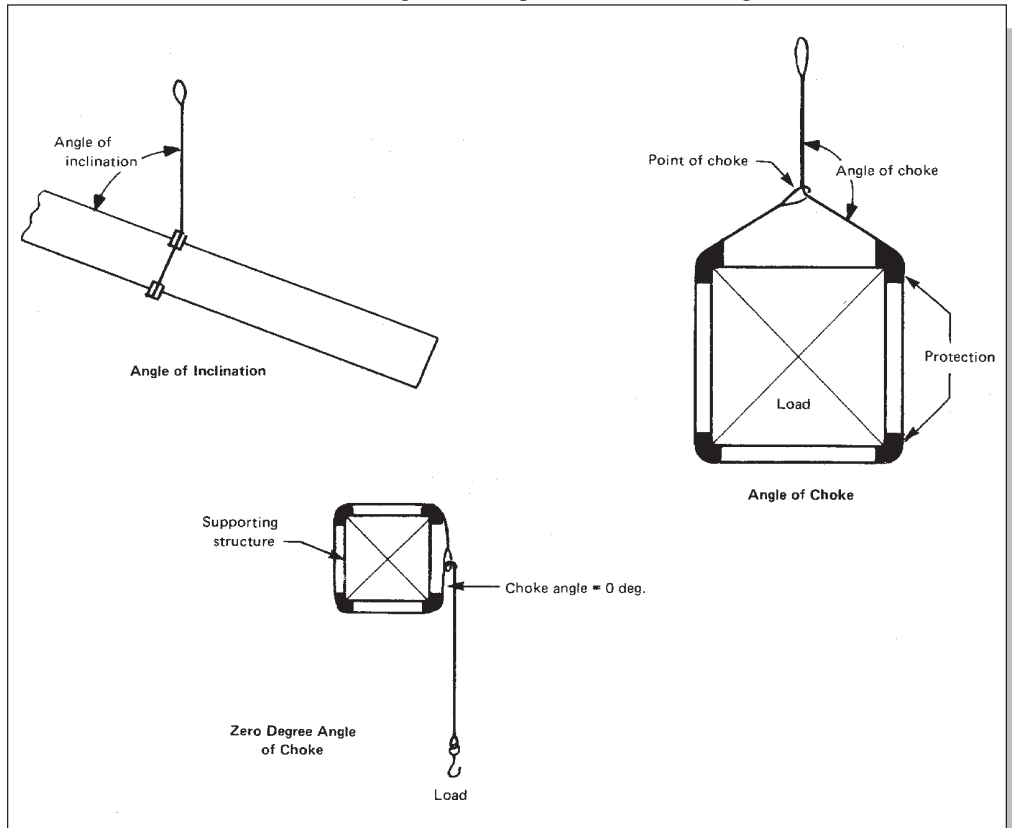

Figure 4.1-6 Choker Hitch Efficiency

4.1.12 Ordering Wire Rope Slings

Minimum purchase requirements for slings are as follows:

- All slings shall be supplied with a certificate of test and examination referencing the unique identify number of the sling.
- All slings are to be pretested to at least 40 percent of breaking strength of the wire rope.
- For all single part slings, rope construction is recommended to be 6 x 37, with an independent wire rope center.

- All slings must have a minimum safety factor of 5.
- All slings must have a steel tag or disk stamped and fixed to the sling uniquely identifying the sling and showing the safe working load and length of the sling.
- All slings will have preformed rope construction.
- All slings are to be righthand lay of improved (or extra improved) plow steel.
- All slings' splices must be steel mechanical splices with stainless steel (or carbon steel) swage sleeves and flemish eyes.
- All slings must be 1 inch wire rope or larger.
- All sling lengths must be specified from bearing point to bearing point and indicate whether the sling length required is for loaded or unloaded condition.
- The minimum safe working load required for the sling must be specified. In some cases, the end connection controls the safe working load and not the breaking strength of the wire rope.
- Slings intended for use in the European Union (EU) shall be supplied with an EC Declaration of Conformity.

4.1.13 Testing Wire Rope Slings

All slings should be ordered proof tested. Wire rope should never be loaded to more than 50 percent of its breaking strength because the approximate elastic limit of conventional wire rope is 55 percent. It is common practice to proof test slings to twice their safe working load. It is recommended that the proof test of a wire rope sling be 40 percent of the breaking strength of the rope, irrespective of the end connection efficiency.

A sling shall not be used unless it's identity can be confirmed, it is tagged, it's original certificate of test and examination can be accessed, and a current report of thorough examination issued by a competent person (preferably 3rd party), and is available. The maximum interval between reports of thorough examination is 12 months for slings in normal use.

All slings shall be visually inspected by the person handling the sling each day before use.

4.1.14 Chain Slings

Chain slings find application where flexibility, ruggedness, abrasion resistance, or high temperature resistance are important. OSHA allows only alloy steel chain for slings. Failure of chain is sudden. If wire rope will do the job, use it instead. See Figure 4.1-7.

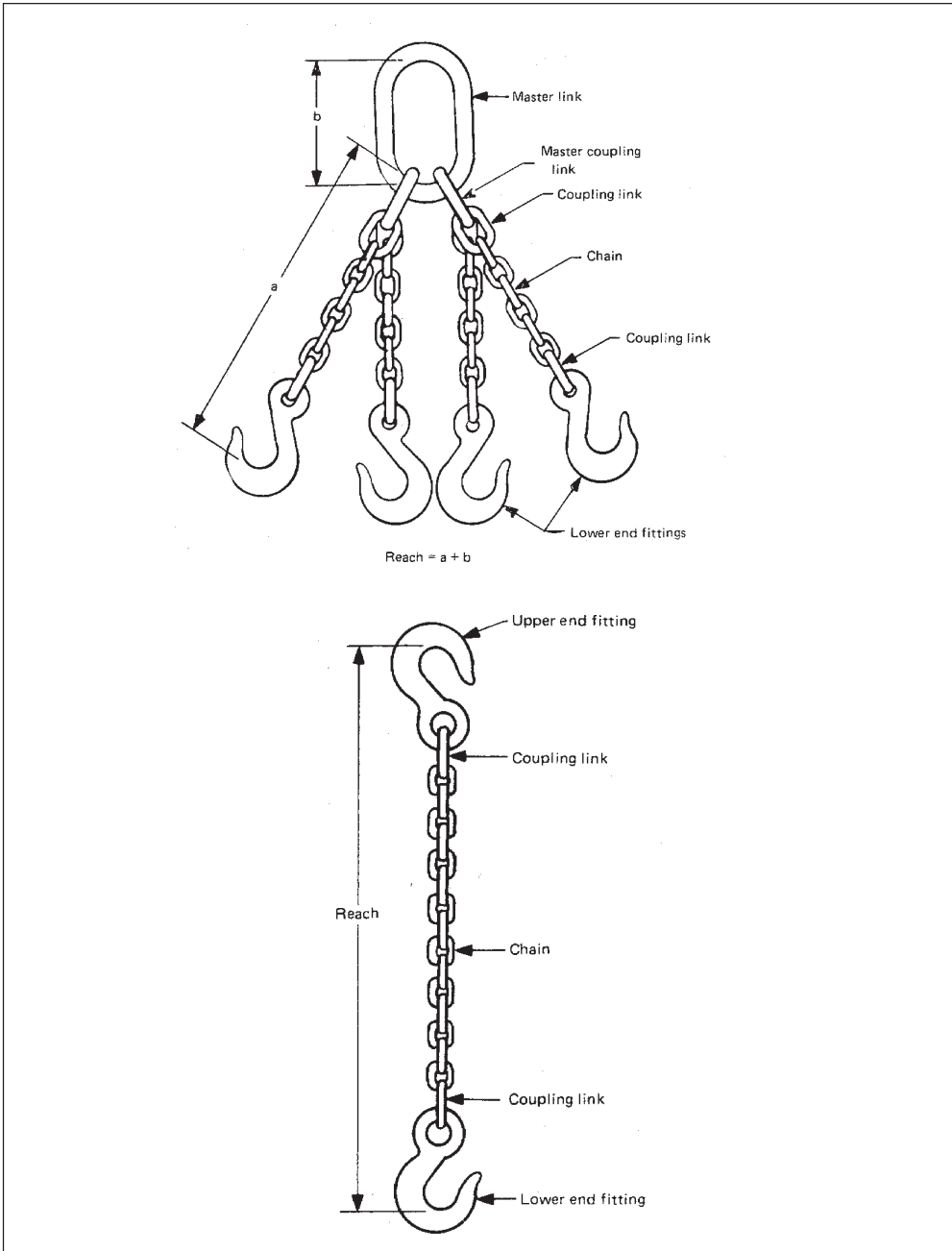

Figure 4.1-7 Chain Sling Major Components

4.1.15 Metal (Wire) Mesh Slings

Wire mesh slings are widely used in metalworking and in other industries where the loads are abrasive, hot, or will tend to cut slings. Unlike nylon, wire mesh slings resist abrasion and cutting. Wire mesh grips the load. Wire mesh can withstand temperatures to 550 °F.

See Figure 4.1-8.

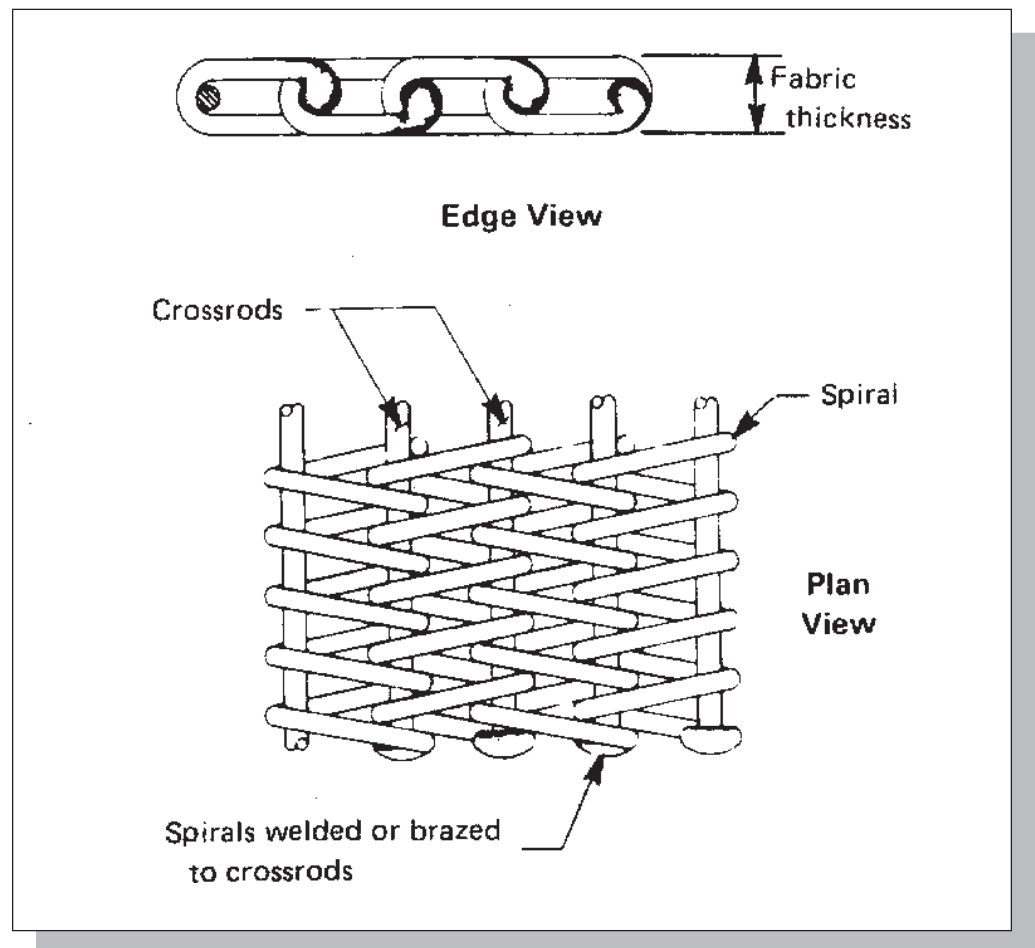



Figure 4.1-8 Metal Mesh Fabric Sling

4.1.16 Synthetic Webbing Slings

Because of their relative softness and width, synthetic webbing slings have less tendency to mar or scratch finely machined, highly polished or painted surfaces and have less tendency to crush fragile objects. Because of their flexibility, synthetic webbing slings tend to mold themselves to the shape of the load. They do not rust and thus do not stain ornamental precast concrete or stone. They are non-sparking and can be used safely in explosive atmospheres. Web slings must not be used at an angle, placing more load on one edge than the other.

See Figure 4.1-9.

CC-93A

BASIC SLING & TIEDOWN CONDENSED CATALOG

WEBMASTER® 1600 AND TUFF-EDGE®

NYLON AND POLYESTER* SLINGS

THE INDUSTRIAL STANDARD HEAVY DUTY SLINGS

ADVANTAGES OF WEBMASTER® 1600 SLINGS

- Features red core warning yarn inspection system.
- Yellow abrasion resistant treatment is standard.
- Webbing is designed specifically for sling applications.
- Webmaster 1600 webbing is approximately 3/16" thick.

ADVANTAGES OF TUFF-EDGE™ NYLON SLINGS

- Webbing designed to resist edge abuse-extend sling life.
- Silver colored body yarns are treated to also resist abrasion.
- Easy identification - silver body and black edges.
- Proven sling web construction with red core warning yarns.
- Tuff-Edge™ webbing is approximately 3/16" thick.

EYE & EYE AND ENDLESS SLINGS



Type 3
(FLAT EYE)



Type 4
(TWISTED EYE)



Type 5
(ENDLESS)

TYPE 3 & 4				TYPE 5				
Web Width	Code	Rated Capacities in Lbs.		Code	Web Width			
		Vertical	Choker V. Basket					
One Ply	1	EE1-801	1,800	1,250	3,200	NA		
	2	EE1-802	3,200	2,500	6,400	NA		
	3	EE1-803	4,800	3,800	9,600	NA		
	4	EE1-804	6,400	5,000	12,800	NA		
	5	EE1-805	8,000	6,400	16,000	NA		
	6	EE1-806	9,600	7,700	19,200	NA		
	8	EE1-808	12,800	10,200	25,600	NA		
	10	EE1-810	16,000	12,800	32,000	NA		
	12	EE1-812	19,200	15,400	38,400	NA		
	Two Ply	1	EE2-801	3,200	2,500	6,400	EN1-801	1
		2	EE2-802	6,400	5,000	12,800	EN1-802	2
		3	EE2-803	9,600	6,900	17,200	EN1-802	3
4		EE2-804	11,500	9,200	23,000	EN1-804	4	
5		EE2-805	13,600	10,900	27,200	EN1-805	5	
6		EE2-806	16,300	13,000	32,600	EN1-806	6	
8		EE2-808	19,200	15,400	38,400	EN1-808	8	
10		EE2-810	22,400	17,900	44,800	EN1-810	10	
12		EE2-812	26,900	21,500	53,800	EN1-812	12	
			6,200	4,900	12,400	EN2-801	1	Two Ply
			12,200	9,800	24,400	EN2-802	2	
			16,300	13,000	32,800	EN2-803	3	
		20,700	16,500	41,400	EN2-804	4		
		24,500	19,600	49,000	EN2-805	5		
		28,600	23,000	57,200	EN2-806	6		
		30,700	24,500	61,400	EN2-808	8		
		33,600	26,800	67,200	EN2-810	10		
		37,600	30,000	75,200	EN2-812	12		

Three and four ply slings are available upon request. Tuff-Edge available in nylon 1" - 6" only. Add a "T" to sling code. *Add a "D" to sling code for polyester.

▲ WARNING To avoid severe injury, refer to ANSI B30.9 guidelines for inspection and use of slings. **DO NOT EXCEED RATED CAPACITIES.**

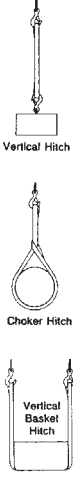

Figure 4.1-9 Nylon Web Sling Capacities

4.1.17 Fiber (Manila-Nylon-Dacron-Polypropylene) Rope Slings

Fiber rope is not recommended for general use in lifting slings.

4.1.18 Polyester and Kevlar Round Slings

Polyester and Kevlar slings have become popular for use on construction sites in recent years. They are composed of a continuous loop of many strands of polyester or Kevlar fiber. This loop of load-bearing material is covered with a durable fabric for protection. Kevlar fiber slings are generally stronger than their polyester counterparts. The advantage of polyester slings over steel slings is that they are lighter in weight and easy to use. They also have an advantage over open web woven slings because of their durability and compactness. See Figures 4.1-10 and 4.1-11.

SLINGMAX®
RIGGING PRODUCTS

Twin-Path® Extra Slings
Twin-Path® Extra Cordura® Slings

Twin-Path® Extra Slings

Twin-Path® Extra Slings are constructed of high performance load carrying yarns.

The load carrying yarns are protected by two independent, seamless, color coded, Polyester covers.

The internal red cover is protected by the outer orange cover.

The sling cover is fabricated in such a way that it is actually two complete and separate slings in one. Each path makes its own separate connection between the lifting hook and the load. This unique back up system is designed to provide the sling user with sufficient reaction time to maintain control of the load if damage to one of the paths went undetected.

Twin-Path® Extra Cordura® Slings

Twin-Path® Extra Cordura® Slings are constructed of high performance load carrying yarns.

Orange Tag Patch - High Performance Load Yarns.

Tell Tails - When Twin-Path® Extra and Twin-Path® Extra Cordura® Slings are loaded beyond their rated capacity, the indicator tails shrink until they finally disappear under the cover.

The load carrying yarns are protected by two independent, seamless, color coded, covers.

The internal Polyester red cover is protected by an outer gray cover of Cordura® Nylon.

Sleeves can be sewn around the body of the sling so that they can be positioned to the areas where they are needed.

ORANGE Polyester Cover GRAY Cordura Cover

A leather tag contains required Information — And the Flag Tag contains the Vertical Capacity in Large Readable Characters.

TWIN-PATH® EXTRA & TWIN-PATH® EXTRA CORDURA® SPECIFICATIONS

United States Patent #4,850,629 Canadian Patent #1,280,458

Twin-Path® Extra Stock No.	Twin-Path® Extra Cordura® Stock No.	Rated Capacities (Lbs.) 5-1 D/F					Approximate Weight (Lbs. Per Ft.) (Bearing-Bearing)	Approximate Body Width (Inches)
		Choker	Vertical	60°	45°	Basket Hitches		
TPX 1000	TPXC 1000	8,000	10,000	20,000	17,320	14,140	.31	3"
TPX 1500	TPXC 1500	12,000	15,000	30,000	25,980	21,210	.40	3"
TPX 2000	TPXC 2000	16,000	20,000	40,000	34,640	28,280	.55	4"
TPX 2500	TPXC 2500	20,000	25,000	50,000	43,300	35,350	.65	4"
TPX 3000	TPXC 3000	24,000	30,000	60,000	51,960	42,420	.80	4"
TPX 4000	TPXC 4000	32,000	40,000	80,000	69,280	56,560	1.12	5"
TPX 5000	TPXC 5000	40,000	50,000	100,000	86,139	70,700	1.50	5"
TPX 6000	TPXC 6000	48,000	60,000	120,000	103,920	84,840	1.60	6"
TPX 7000	TPXC 7000	56,000	70,000	140,000	121,240	98,980	1.68	6"
TPX 8500	TPXC 8500	68,000	85,000	170,000	147,220	120,130	1.85	6"
TPX 10000	TPXC 10000	80,000	100,000	200,000	173,200	141,400	2.20	8"
TPX 12500	TPXC 12500	100,000	125,000	250,000	216,500	176,750	3.00	8"
TPX 15000	TPXC 15000	120,000	150,000	300,000	259,800	212,100	3.36	8"
TPX 17500	TPXC 17500	140,000	175,000	350,000	303,100	247,450	4.00	10"
TPX 20000	TPXC 20000	160,000	200,000	400,000	346,400	282,800	4.37	10"
TPX 25000	TPXC 25000	200,000	250,000	500,000	433,000	353,500	5.50	11"
TPX 27500	TPXC 27500	220,000	275,000	550,000	476,300	388,850	6.90	11"
TPX 30000	TPXC 30000	240,000	300,000	600,000	519,600	424,200	7.50	13"

PLEASE NOTE: Capacities shown include both paths and are for one complete sling. Ratings based on straight pin diameter one-half the sling width.

DO NOT EXCEED RATED CAPACITY **DO NOT EXCEED RATED CAPACITY**

⚠ WARNING Can fail if damaged, misused or overloaded. Inspect before use. Use only if trained. Observe rated capacity. Avoid sharp edges and exposure to acid, alkali, sunlight and temperature over 194°F. DEATH or INJURY can occur from improper use or maintenance.

Figure 4.1-10 Kevlar Sling Capacities



The TUFLEX[®] Family of Polyester Roundslings

Another Lift-All First

ENDLESS (EN)

The Most Versatile
Tuflex Roundslings

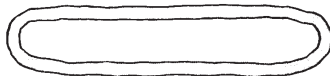

- Wear points can be shifted

CAPACITIES IN LBS.

Code	Color	CAPACITIES IN LBS.		
		Vertical	Choker	Basket
EN30	Purple	2,650	2,120	5,300
EN60	Green	5,300	4,240	10,600
EN90	Yellow	8,400	6,720	16,800
EN120	Tan	10,600	8,500	21,200
EN150	Red	13,200	10,560	26,400
EN180	Orange	16,800	13,440	33,600
EN240	Blue	21,200	17,000	42,400
EN360	Grey	31,700	25,300	63,400
EN600	Brown	52,900	42,300	105,800
EN800	Olive	66,100	52,880	132,200
EN1000	Black	90,000	72,000	180,000

EYE & EYE (EE)

A More Rugged and
Durable Tuflex Roundslings



- Texturized jackets over EN body gives more durability

CAPACITIES IN LBS.

Code	Color of Eyes	CAPACITIES IN LBS.		
		Vertical	Choker	Basket
EE30	Purple	2,650	2,120	5,300
EE60	Green	5,300	4,240	10,600
EE90	Yellow	8,400	6,720	16,800
EE120	Tan	10,600	8,500	21,200
EE150	Red	13,200	10,560	26,400
EE180	Orange	16,800	13,440	33,600
EE240	Blue	21,200	17,000	42,400

Tuflex — General Advantages

- Soft and Pliable
- Choker Hitch Does not Lock-Up on the Load
- Very Consistent Matched Lengths
- 100% of Load on Inside Fibers
- Double Wall Jacket for Added Protection
- Low Stretch — Approximately 3%
- Protects Surface of Load
- Color Coded for Rated Capacity
- Unaffected by UV (Sunlight Degradation)
- Features Red Core Warning Yarn Inspection System
- Cost Effective — Best Price Performer
- Tufhide nylon jackets for improved abrasion resistance on All Sizes Above EN180.

BRAIDED TUFLEX ROUND SLINGS

Huge Capacities of Over
600,000 lbs. are Available



- Multiple part construction for redundant safety

CAPACITIES IN LBS.

Code	Color	CAPACITIES IN LBS.		
		Vertical	Choker	Basket
6 PART TUF-BRAND SLINGS				
B6E30	Purple	6,700	5,300	13,400
B6E60	Green	13,500	10,800	27,000
B6E90	Yellow	21,400	17,100	42,800
B6E120	Tan	27,000	21,600	54,000
B6E150	Red	33,600	26,800	67,200
B6E180	Orange	42,800	34,200	85,600
B6E240	Blue	54,000	43,200	108,000
B6E360	Grey	80,800	64,600	161,600
B6E600	Brown	134,900	107,900	269,800
B6E800	Olive	168,500	134,800	337,000
B6E1000	Black	229,500	183,600	459,000
8 PART TUF-BRAID SLINGS				
B8E30	Purple	9,000	7,200	18,000
B8E60	Green	18,000	14,400	36,000
B8E90	Yellow	28,500	22,800	57,000
B8E120	Tan	36,000	28,800	72,000
B8E150	Red	44,900	35,900	89,800
B8E180	Orange	57,100	45,600	114,200
B8E240	Blue	72,000	57,600	144,000
B8E360	Grey	107,800	86,240	215,600
B8E600	Brown	179,800	143,800	359,600
B8E800	Olive	224,500	179,600	449,000
B8E1000	Black	306,000	244,000	612,000

Figure 4.1-11 Polyester Sling Capacities

4.2 ANCILLARY COMPONENTS

4.2.1 Drums

Hoist drums store, spool, and transmit power to the wire rope. Hoist drums must have power to hoist, lower, hold, immediately stop, and start functions as recommended by the manufacturer.

A hoist drum barrel is grooved to seat the first layer of the wire rope closely and uniformly. The correct way to wind wire rope on a drum will depend on the lay of the rope.

Each turn of the rope around the full circumference of the drum is called a *wrap*. Rope is wrapped around the drum, starting at one end flange and progressing to the other flange, which is called a layer. Drum flanges should extend beyond the fully loaded drum by a minimum of two rope's diameter. The wire rope end is attached to the drum by a socketing or clamping arrangement. A minimum of two wraps must remain on the drum at any time during the hoisting operation when required rope is spooled out. See Figure 4.2-1.

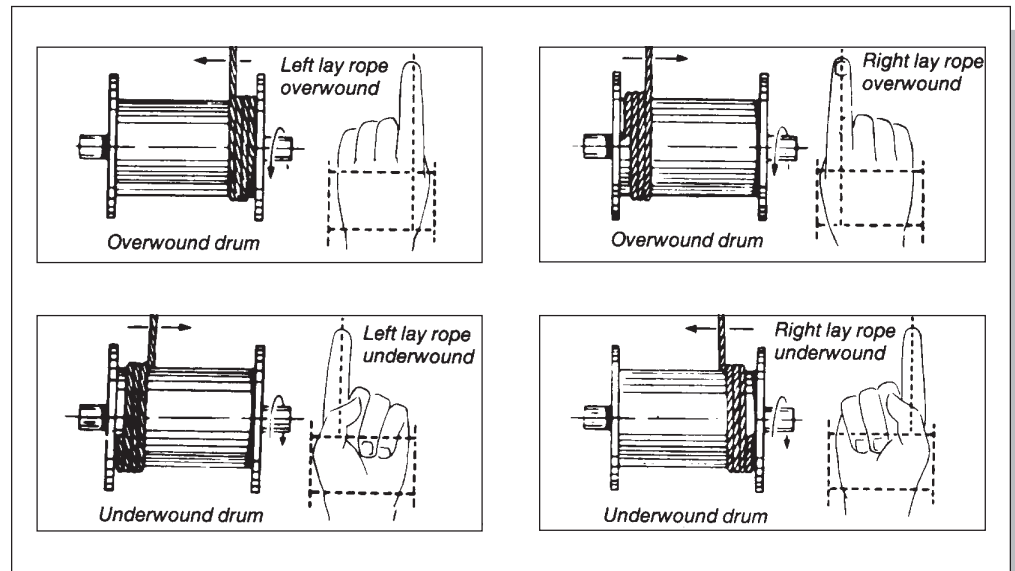

Figure 4.2-1 Rope Winding Directions

It is important to install wire rope on a smooth drum correctly in regard to maintaining a correct relationship between direction of the lay of the rope (right or left) and direction of the rotation of the drum (overwind or underwind), winding from left to right or right to left. For proper installation of the wire rope on a drum, the following measures are required:

- Make sure that the rope is properly attached to the drum
- Maintain sufficient tension on the rope as it is being wound on the drum
- Be certain that each wrap on the drum is guided as close to the preceding wrap as possible
- Use at least two wraps of wire rope on the drum when the rope is fully unwound for any function of the crane lift

Drums should have sufficient rope capacity with proper rope size and reeving to perform all hoisting and lowering functions. In addition, all hoist drums should be provided with adequate means to ensure even spooling of the rope on the drum. Where the operator cannot see the drum or rope, drum rotation indicators should be provided for the operator's sensing. Figure 4.2-2 shows maximum drum capacity.

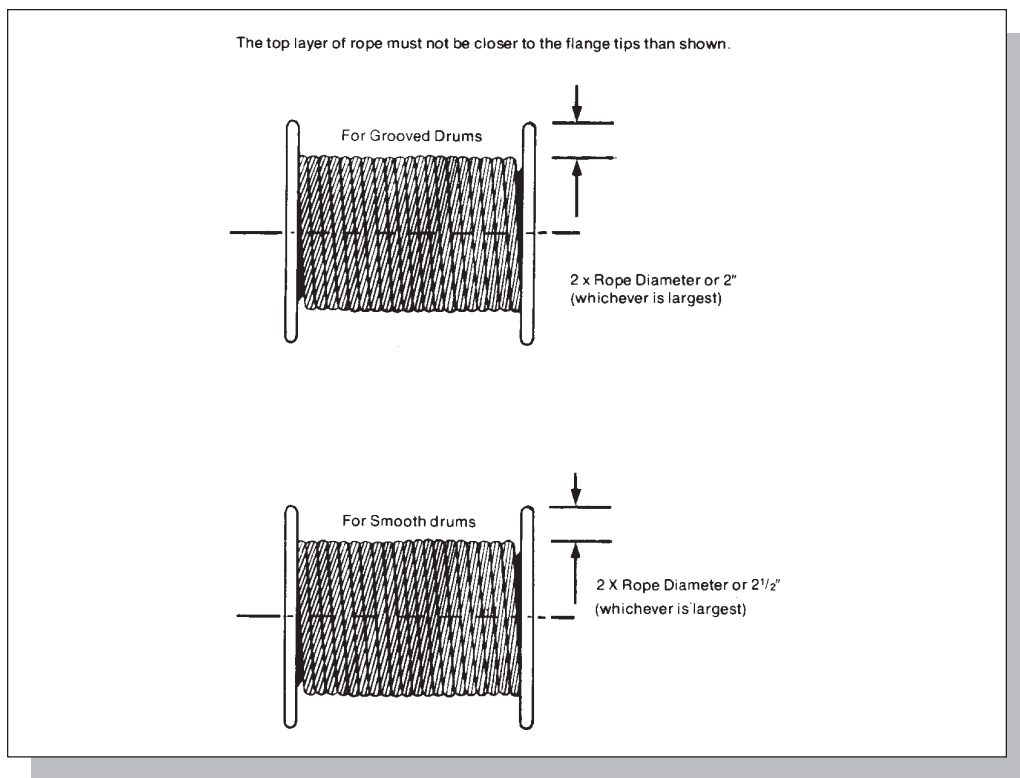

Figure 4.2-2 Drum Capacity

Figure 4.2-3 shows crossover—winding of the rope on the second and all succeeding layers. At these crossover points, the rope is subjected to abrasion and crushing as it is pushed over the two rope grooves and rides across the crown of the first rope layer. Special drum grooving, called counter balance drum grooving, minimizes the crossover damage.

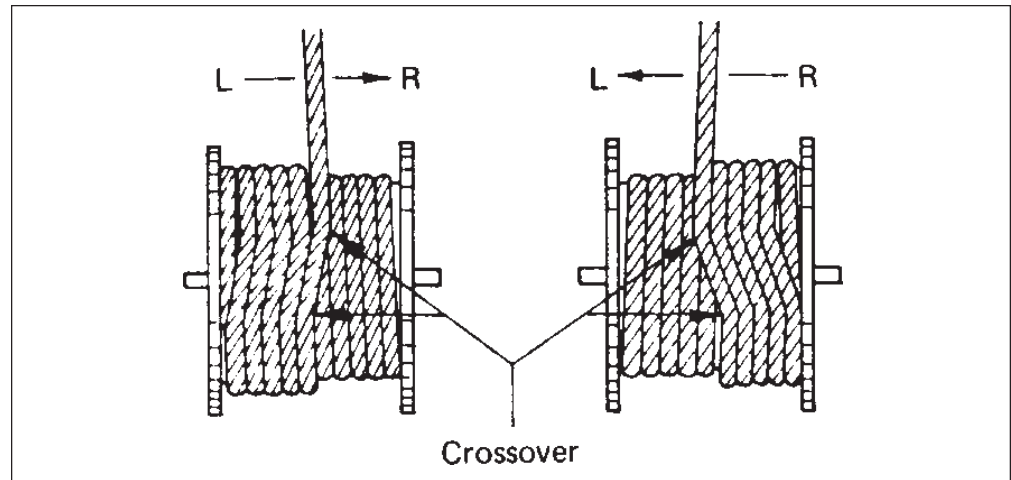

Figure 4.2-3 Drum Crossover

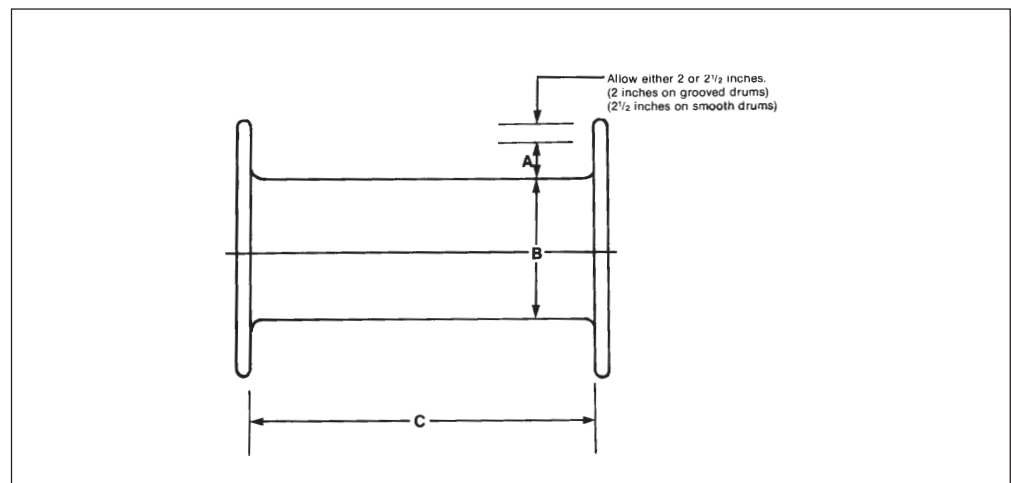

Figure 4.2-4 Drum Dimensions

4.2.2 Drum Capacity

To determine the length of wire rope that can be spooled on a drum:

$$L=(B + A) \times A \times C \times F$$

L is in feet. A, B, and C are in inches. Spooling factor F applies to nominal rope size and tightness of wraps and is provided in Table 4.2-1. Also see Figure 4.2-4.

Table 4.2-1 Drum Capacity Factors

DRUM OR REEL CAPACITY FACTOR	
Nominal Rope Diameter (Inches)	F
1/4	4.160
5/16	2.670
3/8	1.860
7/16	1.370
1/2	1.050
9/16	0.828
5/8	0.672
3/4	0.465
7/8	0.342
1	0.262
1 1/8	0.207
1 1/4	0.167
1 3/8	0.138
1 1/2	0.116
1 5/8	0.099
1 3/4	0.085
1 7/8	0.074
2	0.066
2 1/8	0.058
2 1/4	0.052
2 3/8	0.046
2 1/2	0.042

The ratio of the drum diameter to the rope diameter (D/d) for cranes and derricks is set by ASME B-30.5. For load hoisting, D/d will not be less than 18 and for boom hoist, not less than 15. However, to minimize the rope bending stresses, the drum diameter should be at least as large as indicated in Table 4.2-2.

Table 4.2-2 Minimum Required Drum Diameters

Rope Diameter (Inches)	DRUM DIAMETER (INCHES) FOR VARIOUS TYPES OF ROPES				
	6 x 7	6 x 19 18 x 7 N.R.	6 x 19 Warr. 6 x 16 F 6 x 27 F.S.	6 x 19 F 8 x 19 Seale	6 x 37
1/4	10	8	7	6	5
5/16	13	11	9	8	6
3/8	16	13	11	10	7
7/16	18	15	13	11	8
1/2	21	17	15	13	9
9/16	23	19	17	15	10
5/8	26	21	19	16	11
3/4	31	25	22	19	13
7/8	37	30	26	23	16
1	42	34	30	26	18
1 1/8	47	38	34	29	20
1 1/4	52	42	37	32	22
1 3/8	58	47	41	36	25
1 1/2	63	51	45	39	27
1 5/8	—	55	49	42	29
1 3/4	—	59	52	45	31
1 7/8	—	64	56	49	34
2	—	68	60	52	36
2 1/4	—	—	67	58	40
2 1/2	—	—	75	65	45

As shown in Figure 4.2-5, drum radial contact pressure can be determined by:

$$P = 2L/Dd$$

P= Radial pressure in psi, L= rope load in pounds, D= drum diameter, and d= rope diameter.

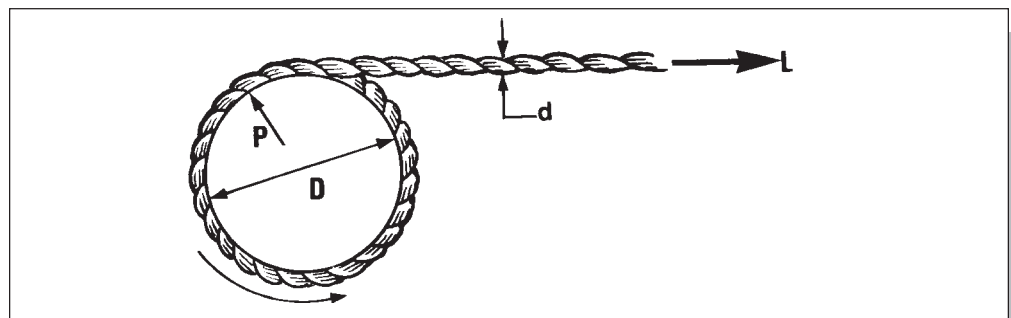

Figure 4.2-5 Wire Rope Contact Pressure

Example:

From the data in Table 4.2-2, determine wire rope contact pressure on the drum using 1 inch, 6 x 37 IWRC, having 16,000 lb swl, and 24 inch drum diameter:

$$P = 2 \times 16000 / 24 \times 1 = 13,33 \text{ psi}$$

4.2.3 Fleet Angle

For proper spooling, and to prevent excessive wear on the drum grooves, the angle at which the rope leads to the drum, called the *fleet angle*, must be within controlled limits. Figures 4.2-6 and 4.2-7 present fleet angle definitions and recommended fleet angles.

Fleet angle should be within 1 to 2 degrees for smooth drums and not more than 1 1/4 degrees for groove drums. If the fleet angle is too small, it will result in considerable vibration, causing rope to pile up against the drum flange. This damages the rope and the equipment. If the fleet angle is too large, the rope will rub against the flanges of the sheave groove or be crushed on the drum. When it is not possible to place a lead sheave at the required distance from the drum, a pivoted block or fleeting sheave is used. A fleeting sheave is placed on a horizontal shaft, which allows the sheave to move laterally.

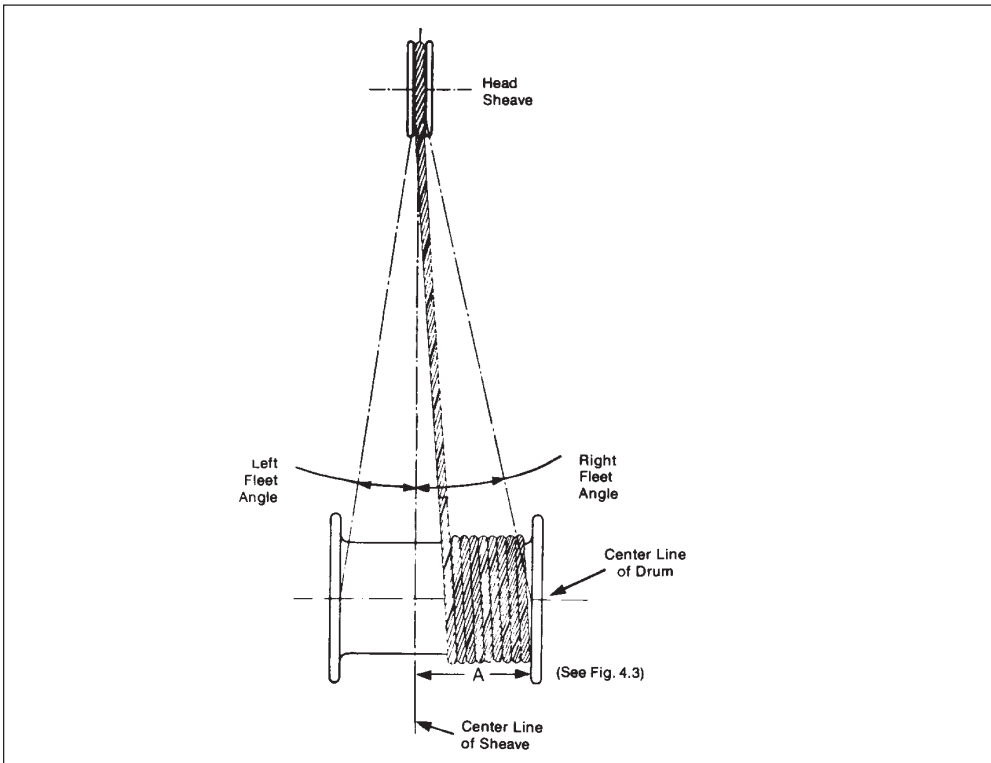

Figure 4.2-6 Definition of Fleet Angle

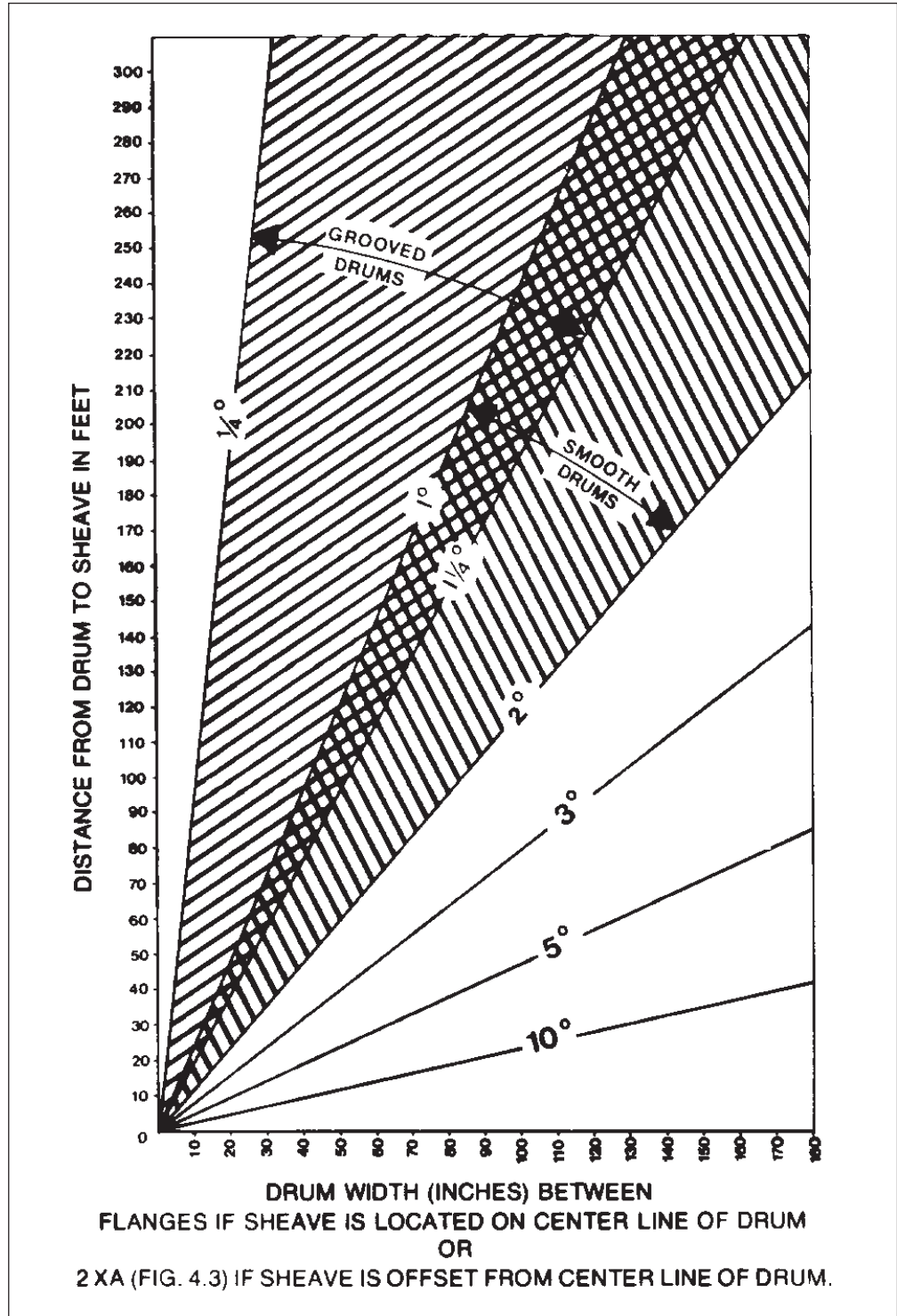

Figure 4.2-7 Recommended Fleet Angles

4.2.4 Sheaves

Sheaves are used to change travel direction of the wire ropes. Sheaves assembled in multiples form blocks that provide the required mechanical advantage. The condition and contour of sheave grooves play a major role in the useful life span of the wire rope and sheave. As discussed earlier, a 2-degree fleet angle is recommended. However, constant misalignment causes the rope to rub the sides of the groove, resulting in wear of the rope and sheave. The grooves must be smooth and slightly larger than the rope to prevent it from being pinched or jammed in the groove. Table 4.2-3 shows the sheave groove tolerances.

Table 4.2-3 Sheave Groove Tolerances

SHEAVE GROOVE TOLERANCES		
Nominal Rope Diameter (Inches)	Groove Oversize (Inches)	
	Min.	Max.
$1/4$ — $5/16$	$1/64$	$1/32$
$3/8$ — $3/4$	$1/32$	$1/16$
$13/16$ — $1\ 1/8$	$3/64$	$3/32$
$1\ 3/16$ — $1\ 1/2$	$1/16$	$1/8$
$1\ 9/16$ — $2\ 1/4$	$3/32$	$3/16$
$2\ 5/16$ up	$1/8$	$1/4$

The bottom of the groove should have an arc of support of at least 120 to 150 degrees, and the sides of the groove should be tangent to the arc. Figure 4.2-8 shows a proper arc of support for rope by a sheave. In addition, the figure shows the effects of too large and too small diameter of rope on the sheave.

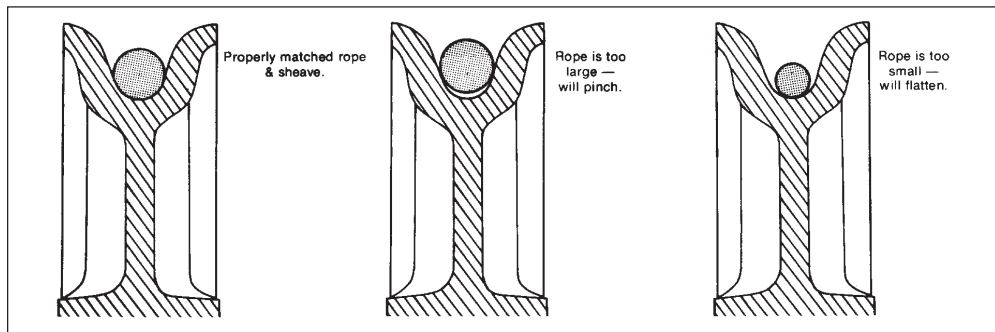

Figure 4.2-8 Matching of Ropes and Sheaves

If the groove diameter is too large, the rope will not be properly supported and will tend to flatten and become distorted. Figure 4.2-9 shows the effect of an improperly matched sheave and wire rope.

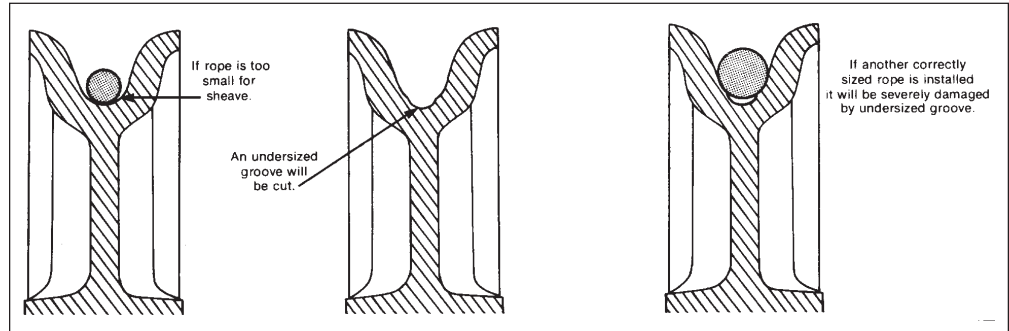

Figure 4.2-9 Effects of an Improper Match Between Rope and Sheave

Figure 4.2-10 shows a badly damaged sheave and how sheave grooves are to be checked for proper wire rope size.

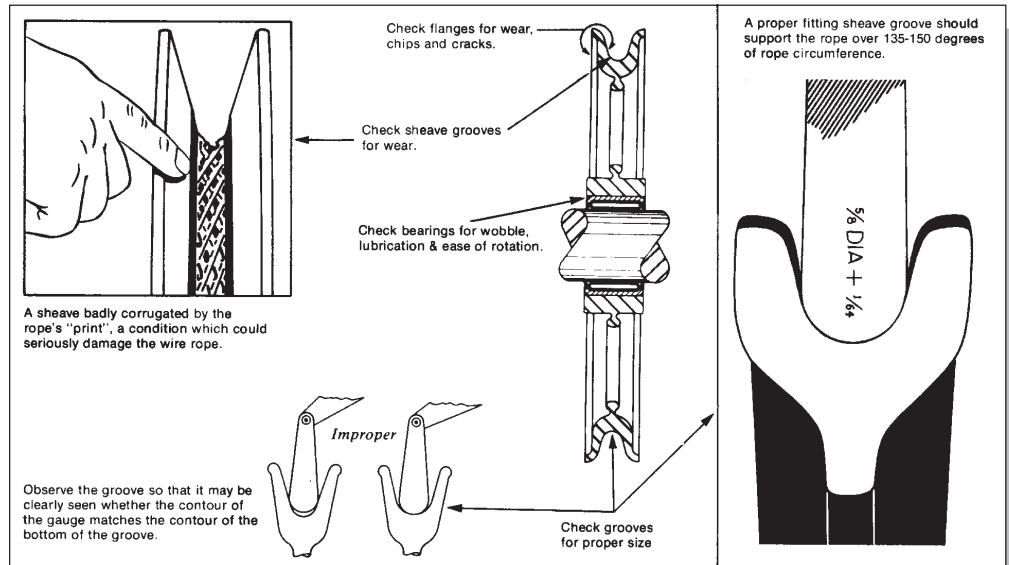

Figure 4.2-10 Inspecting Sheave Groove

The depth of the sheave grooves should be at least 1-1/2 times the rope's diameter, and the tapered side walls of the grooves should not make an angle greater than 18 degrees with respect to the centerline. The flange corners should be rounded, and the rims should run true about the axis of rotation. The bearings should be permanently lubricated or be equipped with a means for lubrication. Figure 4.2-11 shows the sheave requirements.

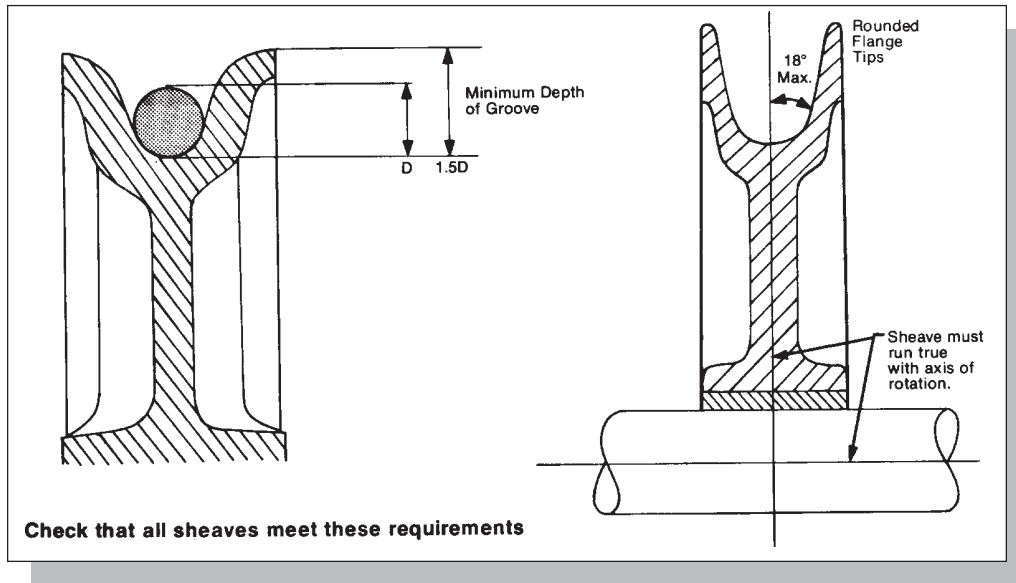

Figure 4.2-11 Sheave Measurements

Sheave and drum diameters have a direct bearing on rope life. One of the fastest ways to ruin a wire rope is to operate it over too small a sheave. All wire ropes operating over sheaves and drums are subject to cyclic bending stresses. The magnitude of stress depends on the ratio of the diameter of the sheave or drum to the diameter of the wire rope (D/d). Table 4.2-4 suggests the minimum D/d ratios for various rope construction.

Table 4.2-4 Sheave Diameter Factors

Rope Construction	For Ropes Subjected Primarily to Bending Stresses	General Purpose Range D/d Ratios	
		Recommended	Minimum
6x7	72	63	42
18x7	51	54	36
6x17 Seale	56	49	33
6x19 Seale	51	45	30
6x21 Filler Wire	45	39	26
6x25 Filler Wire	41	36	24
6x31	38	33	22
8x19 Seale	36	31	21
6x37	33	27	18
8x19 Warrington	31	27	18
Tiller Rope	20	18	12

The ratio of sheave and drum to rope diameter for cranes and derricks—stipulated by ASME standards—is fixed and does not vary with rope life parameters. The winding drum and upper block sheave diameters will not be less than 18 times the wire rope diameter, while the lower block sheave diameter will not be less than 16. These ratios apply to the load hoisting systems of construction cranes and derricks. The ratios for overhead and industrial cranes are more conservative.

There is no minimum sheave or drum diameter that prevents a hoisting mechanism from operating. However, as shown in Figure 4.2-12, a wire rope's life decreases with decreasing sheave and drum diameters.

Relative bending life factors show that rope construction has a direct relation to the bending stress concerning longer service of the rope. For example, changing from 6 x 25 filler wire (FW) with a factor of 1 to a 6 x 36 Warrington Seale (WS) with a factor of 1.15 means that the service life of the rope could be increased by 15 percent.

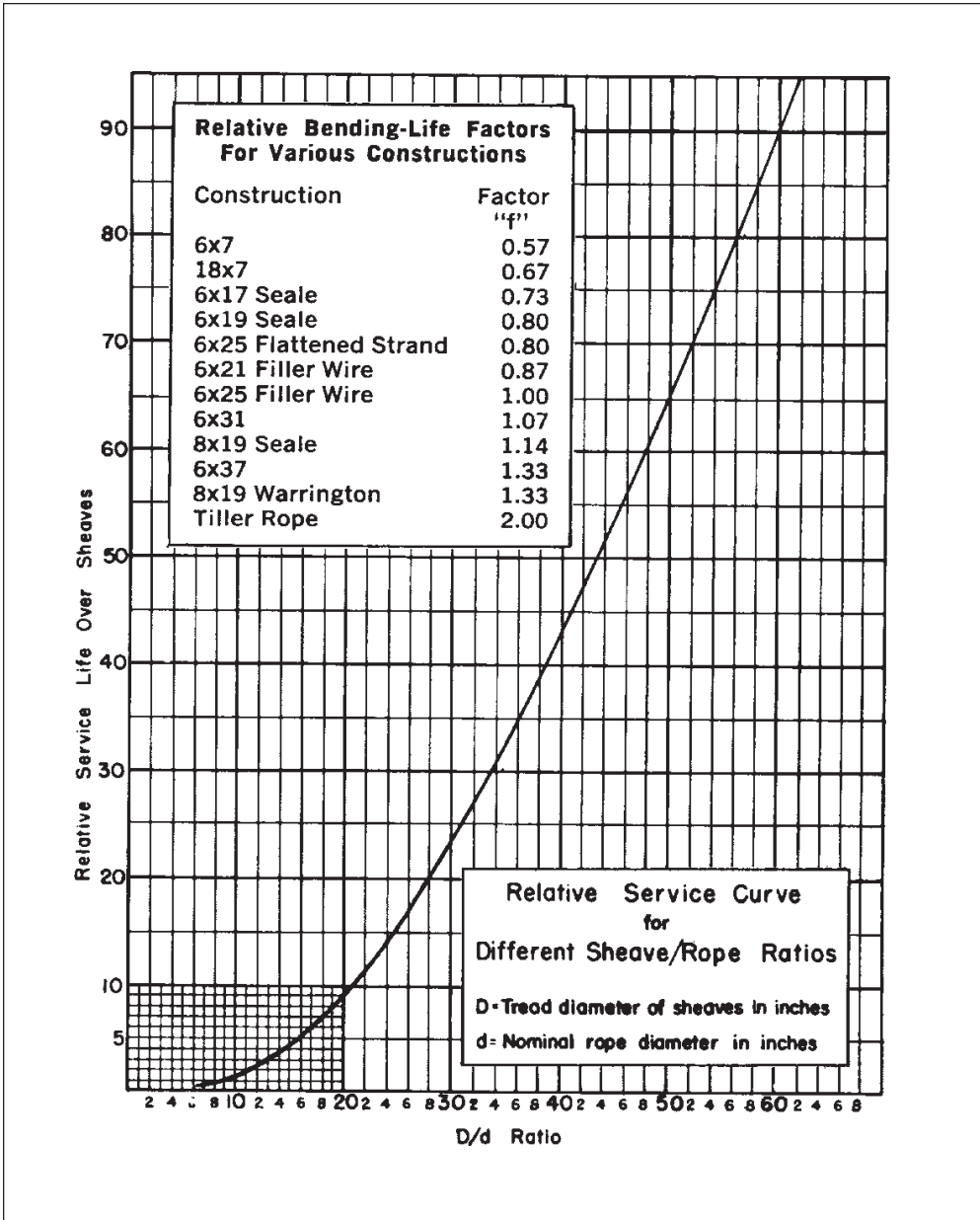

Figure 4.2-12 Service Life of Wire Rope

Example:

A rope working with a D/d ratio of 26 has a relative service life of 17. If the same rope works over a sheave that has a D/d ratio of 35, the relative service life increases to 32, which means an 88 percent increase in service life.

4.2.5 Blocks

A block is a frame that encloses one or more sheaves and is provided with a hook or some other means that allows attachment to cargo or to a fixed anchor point. The purpose of a block is twofold. First, it is used to change direction of a wire rope line. Second, when used in pairs, blocks increase mechanical advantage by allowing the use of multiple parts of line. Blocks range in size from several pounds capacity to hundreds of tons.

There are three basic types of blocks: crane, snatch, and wire rope (construction or fixed) blocks. Snatch blocks refer to a group of intermittent service blocks that jerk or snatch their load over comparatively short distances. Snatch blocks are characterized by a side-opening plate that facilitates threading the wire rope through the block. As opposed to a snatch block, a crane block is required to perform long lifts under continuous service conditions. Crane blocks are characterized by multiple large diameter, long service life sheaves, and the addition of cheek plate weights to the block side frames to increase overhaul weight. Crane blocks typically are outfitted with a swivel hook that allows the cargo to be rotated without fouling the multiple parts of reeving. Fixed blocks or construction blocks are typically used as upper blocks in multi-part reeving arrangements in derricks or material hoists. As such, they have large diameter multiple sheaves like crane blocks but the lack the additional cheek plate weights required for overhaul.

A block consists of a shell (or side plates), a center pin, and an end fitting. There are a variety of end fittings such as hooks, shackles, and clevises that facilitate attachment of the block to the cargo or to a fixed anchorage. Blocks are also equipped with a becket or mouse ear whereby the end of the rope line is affixed to the block. The sheaves of the block transmit the load from the wire rope to the center pin and then to the shell straps or side plates. Figures 4.2-13, 4.2-14, and 4.2-15 provide illustration of wire rope blocks, crane and hook blocks, wire rope blocks, and snatch blocks.

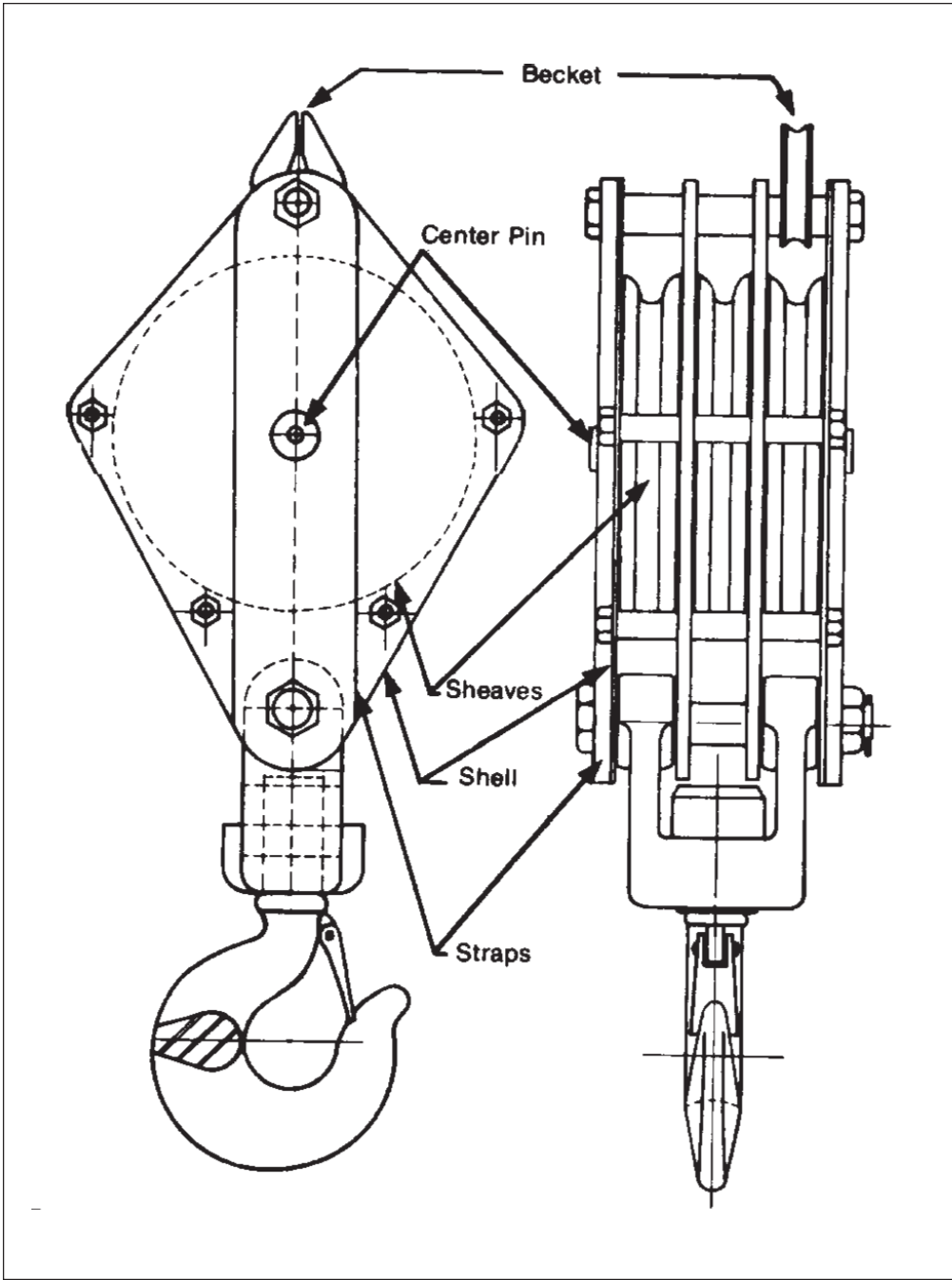

Figure 4.2-13 Typical Wire Rope Block

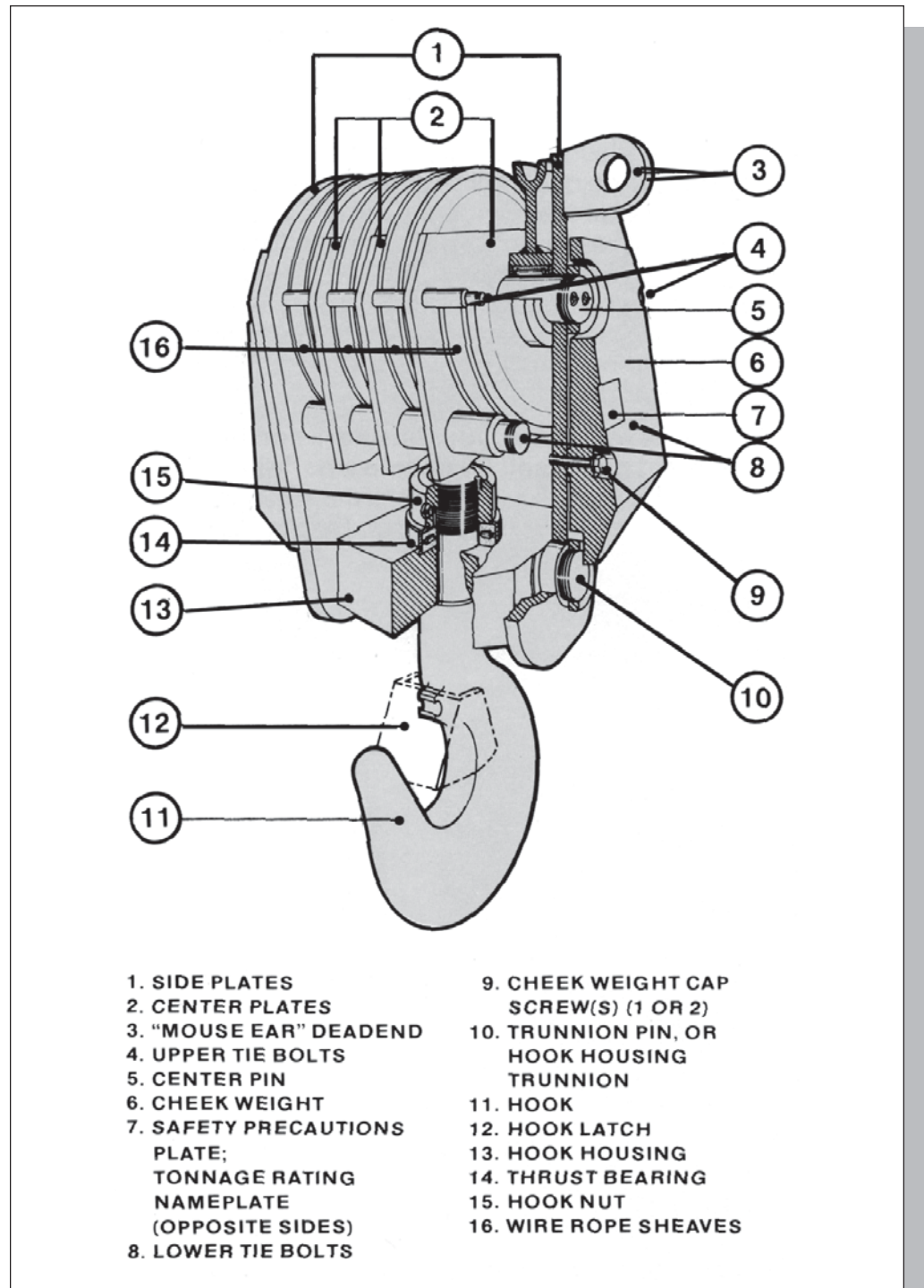

Figure 4.2-14 Typical Crane and Hook Block

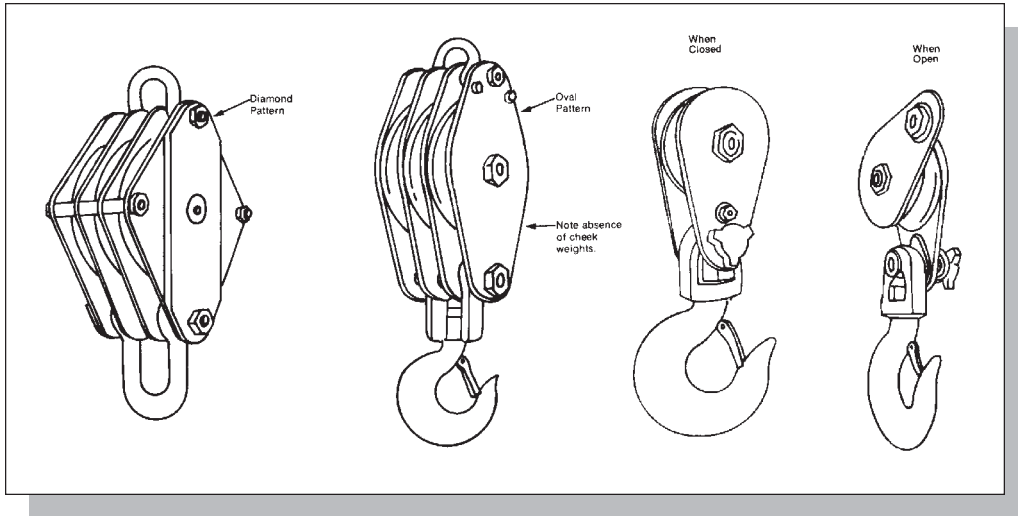

Figure 4.2-15 Various Wire Rope Blocks and Snatch Blocks

4.2.6 Center Pin

The center pin of the block is the sheave bearing shaft. There are a variety center pin bearing designs. Figure 4.2-16 illustrates different sheave bearings.

- **Plain bore sheave**—A cast iron sheave bearing is the center pin. A plain bore sheave requires frequent lubrication and is used for a light load.
- **Roller bushed sheave**—Roller bushed sheaves are made with unground rollers and without races. They are recommended for light service use and must be lubricated.
- **Self-lubricating bronze bearing sheave**—This block is used when it is difficult to service or provide lubrication. It should not be subject to frequent use or high speeds because the graphite wax mixture providing frictionless properties will be destroyed.
- **Pressure-lubricated bronze bearing sheave**—These sheaves are recommended for heavy and continuous loads. Periodic and frequent lubrication is required.
- **Roller bearing sheaves**—Having ground rollers and full races, roller bearing sheaves are recommended for medium duty and high speed operation.
- **Precision anti-friction bearings**—Suited for high speed, heavy loads and minimum maintenance, precision anti-friction bearings can handle both radial and thrust loads.

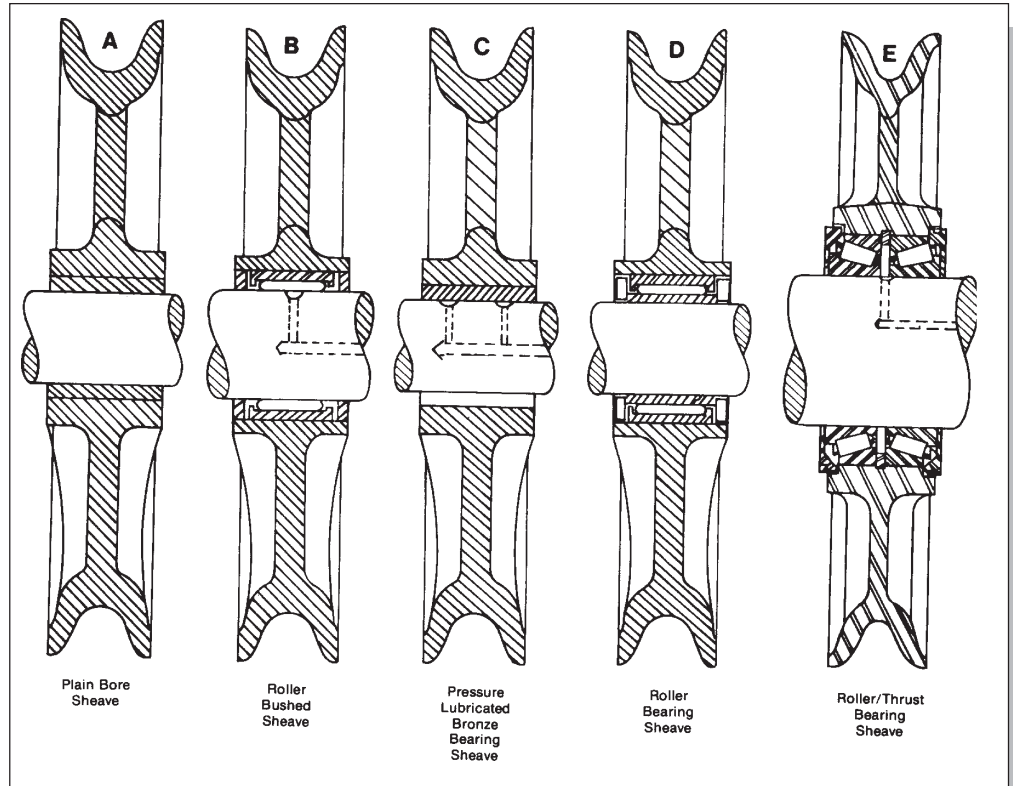

Figure 4.2-16 Sheave Bearing Configurations

4.2.7 Selection of a Block

When blocks are selected, the governing consideration should be the load to be handled rather than diameter or strength of the rope they will carry. In multiple sheave blocks, the load is distributed among several parts of the rope, whereas the hooks or shackles on the blocks have to carry the entire load. It is recommended that for heavy loads and fast hoisting, roller or bronze bearings be used. The block anchor point must be able to support the total weight of the load, plus the weight of the blocks and the load applied on the lead line.

Snatch blocks are single or double sheave blocks manufactured with hook, shackle eye, and swivel end fittings. Snatch blocks are normally used for changing the direction of the pull on a line. The stress on the snatch block varies with the angle between the lead and load line. When the two lines are parallel, 2,000 pounds on the lead line results in a load of 4,000 pounds on the block. Table 4.2-5 lists the multiplication factors for snatch block loads. Figure 4.2-17 shows variations of snatch block loads with rope angles.

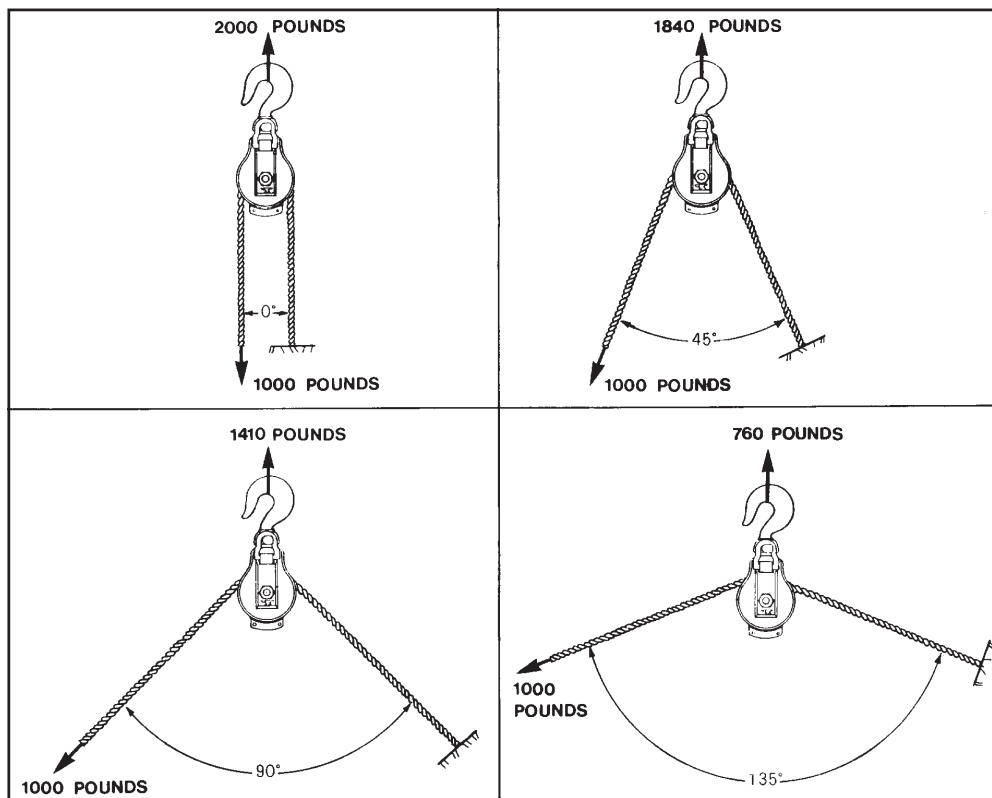

Figure 4.2-17 Variation of Snatch Block Loads With Rope Angles

Table 4.2-5 Multiplication Factors For Snatch Block Loads

MULTIPLICATION FACTORS FOR SNATCH BLOCK LOADS	
Angle Between Lead and Load Lines	Multiplication Factor
10°	1.99
20°	1.97
30°	1.93
40°	1.87
50°	1.81
60°	1.73
70°	1.64
80°	1.53
90°	1.41
100°	1.29
110°	1.15
120°	1.00
130°	.84
140°	.68
150°	.52
160°	.35
170°	.17
180°	.00

4.2.8 Inspection of Blocks

Several basic inspection points must be checked to ensure safe block operation. Check the blocks for excessive wear on the becket, end connections, sheave bearings, and center pin. Check the sheaves for proper rotation. Ensure that guards (cable keepers) are in place. Ensure that sheave grooves are smooth. Check for signs of overloading, elongated links, bent shackles, links or center pin, and/or enlarged hook throat.

4.2.9 Rigging of a Block

Two basic methods exist for rigging the rope through a set of blocks. First, during reeving, the upper and lower blocks are rotated 90 degrees from each other. (See Figure 4.2-18.) Reeving has an inherent tendency to be tilt resistant, thus stabilizing the lower block and allowing it to hang level. However, it requires a large minimum distance between the upper and lower blocks (two-block distance) to accommodate the required fleet angle. Second, during lacing, normally two small sheave crane blocks are rigged up. Lacing is simple to perform and allows the

distance between the lower and upper blocks to be safely minimized. The disadvantage is that the arrangement has a tendency to tilt the lower block because of uneven sheave friction. This tendency becomes more pronounced as line parts are increased. There are variations to both methods or rigging that strike a balance between tilt limiting, block rotation, and minimum two-block distance.

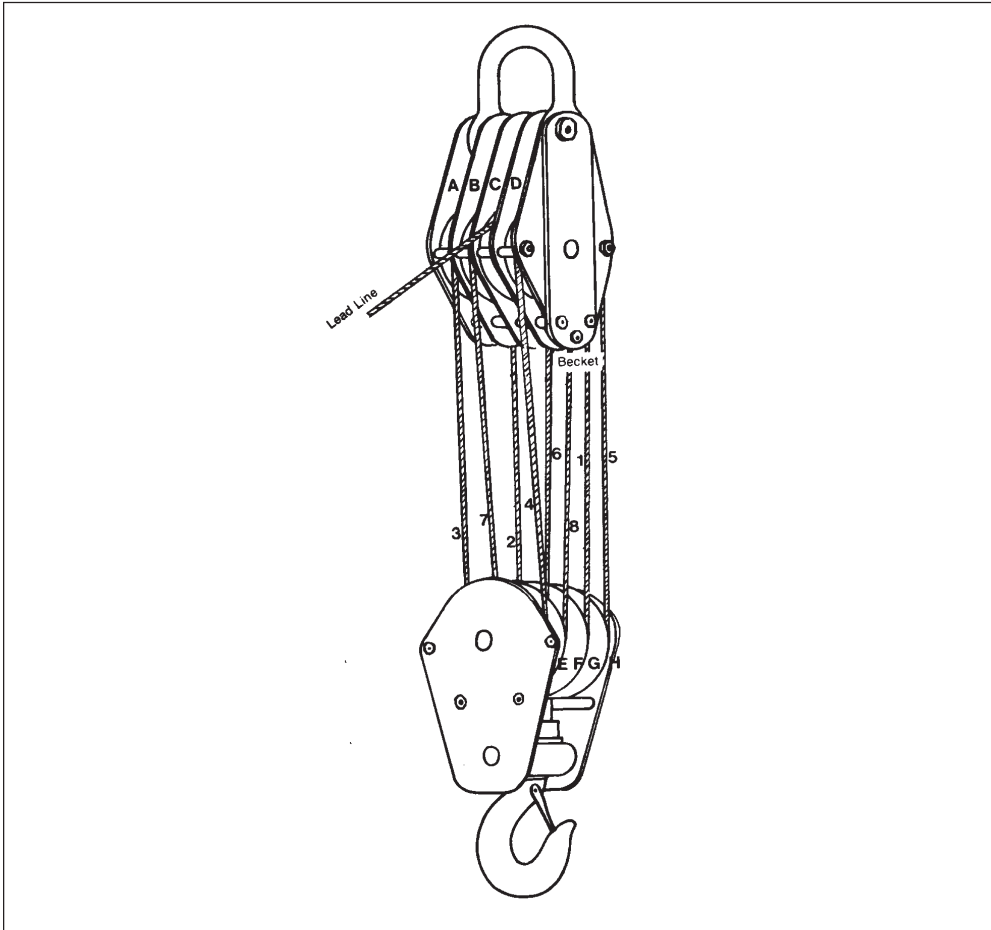

Figure 4.2-18 Reeved Block Arrangement

It is extremely important to properly secure (wedge socket or cable clip) the becket connection or dead end of the wire rope properly. Figure 4.2-19 shows the correct and incorrect method of securing the end of wire rope.

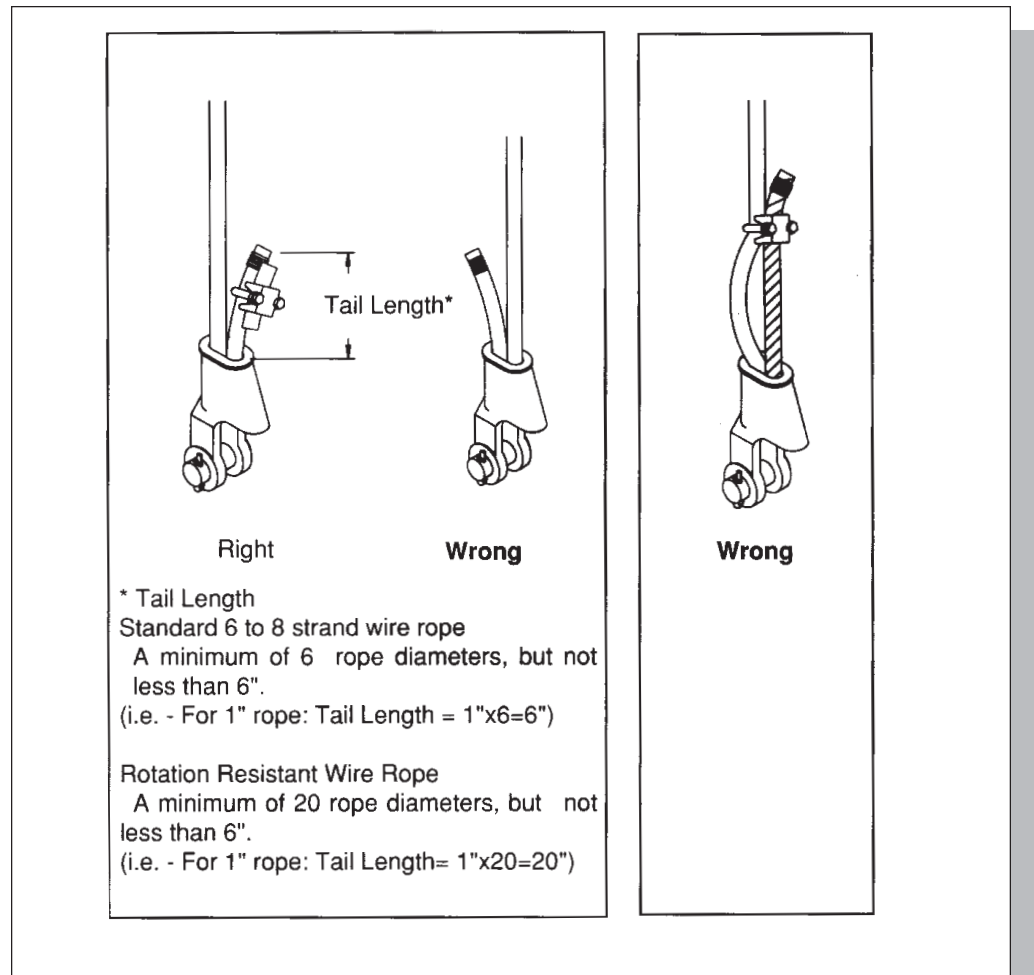

Figure 4.2-19 Wire Rope End Connection (Becket)

4.2.10 Mechanical Advantage

When rigged, blocks become a device or system by which forces are multiplied to do the work. A lead line pull is multiplied to lift the load with deductions for friction losses due to sheaves bearing and rope traveling over the sheaves. Figure 4.2-20 shows that an extra force is required to overcome the friction to keep the weight moving. The mechanical advantage for any multiple part system is always equal to the number of parts of line supporting the running block (hook block) and the load. **The lead line should not be included.** A conservative value for friction loss on blocks having plain bore sheaves is 10 percent, for bronze bushing is 5 percent, and for roller bearings is 3 percent. When the load is lifted, each sheave introduces friction force equal to 10 percent, 5 percent, or 3 percent of the load being carried, depending on the sheave bearings used.

Example:

Using Figure 4.2-20, a load weighing 10,000 lb, having four parts of line marked A, B, C, and D, and using blocks with bronze bushing sheaves, determine the lead line pull E:

Load at A=2,500 lb

Load at B= 2,500 lb + 5% of 2,500 = 2,625 lb

Load at C=2,625 + 5% of 2,625 = 2,756 lb friction @ sheave 2

Load at D=2,756 + 5% of 2,756 = 2,894 lb friction @ sheave 3

Load at E=2,894 + 5% of 2,894 = 3,038 lb friction @ sheave 4

Therefore, to lift the 10,000 lb, the lead line pull must be equal to or greater than 3,038 lb. (The wire rope SWL is sized to the lead line pull.)

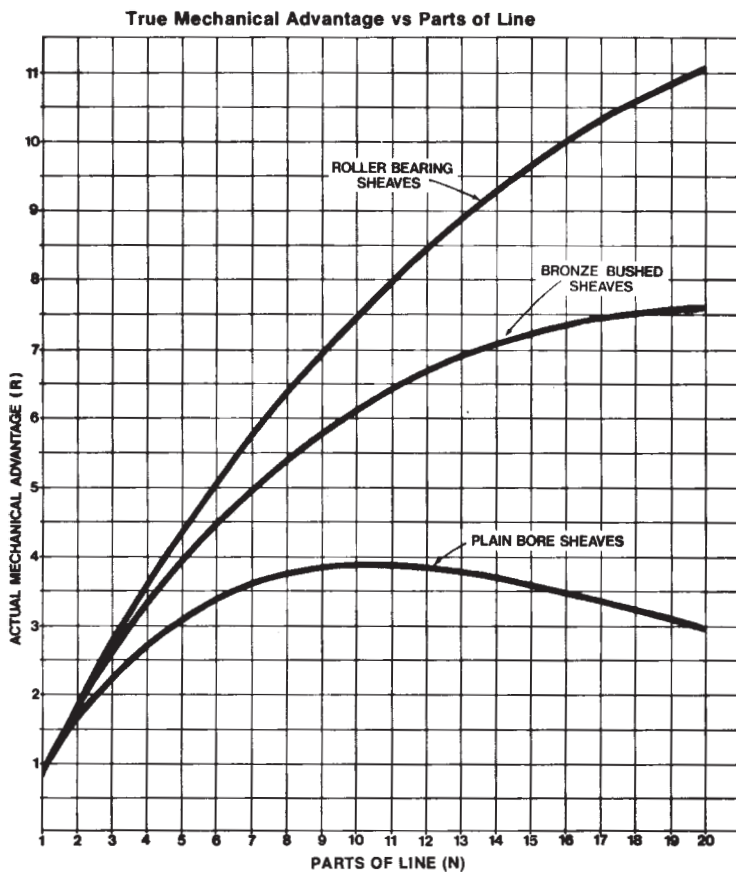

Figure 4.2-20 Mechanical Advantage of Line Parts

For simplification, Table 4.2-6 furnishes multiplication factors and ratios for a sheave friction of 5 percent for bronze bushing sheaves and stiff roller bearing sheaves and 3 percent for good roller bearing sheaves.

$$\text{Lead Pull} = \frac{\text{LOAD TO BE LIFTED}}{\text{PARTS OF LINE}} \times F \text{ sheave unit mult. factor}$$

$$\text{Mechanical Advantage} = \frac{\text{LOAD TO BE LIFTED}}{\text{ROPE SWL OR LOAD LINE PULL}}$$

Example:

Determine the number of parts of line for a crane to lift a 75-ton load. The crane has roller bearing sheave blocks and the wire rope SWL is 11 tons.

$$\text{Mechanical advantage ratio } R = 75 \text{ ton}/11 \text{ ton} = 6.8$$

Table 4.2-6 for roller bearing sheaves shows that for ratio R value of 6.8, use nine parts of line.

Table 4.2-6 Sheave Friction Loss Factors

FACTORS TO ACCOUNT FOR SHEAVE FRICTION LOADS FRICTION FORCE = 5% of Sheave Load (Typical for bronze bushing sheaves and stiff roller bearing sheaves.)		
Number of Parts of Line N	Multiplication Factor F	Ratio R (R = N/F) = Actual Mechanical Advantage
1	1.05	.95
2	1.10	1.82
3	1.16	2.59
4	1.22	3.28
5	1.28	3.91
6	1.34	4.48
7	1.41	4.96
8	1.48	5.41
9	1.55	5.81
10	1.63	6.13
11	1.71	6.43
12	1.80	6.67
13	1.89	6.88
14	1.98	7.07
15	2.08	7.21
16	2.18	7.34
17	2.29	7.42
18	2.41	7.47
19	2.53	7.51
20	2.65	7.55

FACTORS TO ACCOUNT FOR SHEAVE FRICTION LOADS FRICTION FORCE = 3% of Sheave Load (Typical for good roller bearing sheaves.)		
Number of Parts of Line N	Multiplication Factor F	Ratio R (R = N/F) = Actual Mechanical Advantage
1	1.03	.97
2	1.06	1.89
3	1.09	2.75
4	1.13	3.54
5	1.16	4.31
6	1.20	5.00
7	1.23	5.69
8	1.27	6.30
9	1.31	6.87
10	1.35	7.41
11	1.39	7.91
12	1.43	8.39
13	1.47	8.84
14	1.51	9.27
15	1.56	9.62
16	1.61	9.94
17	1.65	10.30
18	1.70	10.59
19	1.76	10.80
20	1.81	11.05

4.2.11 Hooks

Most hooks are constructed from forged alloy steel and are stamped with their rated safe working loads (SWLs). The SWL applies only when the load is applied to the saddle of the hook. When the hook is eccentrically loaded, hook capacity SWL must be reduced. All hoisting hooks must be equipped with safety catches.

During inspection of hooks, look for cracks, severe corrosion, twisting of hook body, and opening of the throat. Hook efficiency is illustrated in Figure 4.2-21.

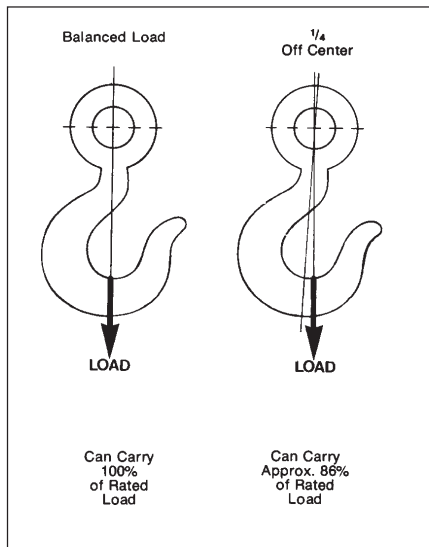





Figure 4.2-21 Hook Efficiency

Table 4.2-7 Hook Types and Throat Openings

EYE HOOKS, SHANK HOOKS, SWIVEL HOOKS FORGED ALLOY STEEL (SAFETY FACTOR = 5)		
 Eye Hook	 Swivel Hook	 Shank Hook
Throat Opening (Inches)	Maximum Safe Working Load (Pounds)	
5/8	600	
11/16	800	
1	1,500	
1 1/16	2,000	
1 1/8	2,500	
1 1/4	4,000	
1 3/8	4,500	
1 13/32	5,000	
1 1/2	5,500	
1 17/32	6,000	
1 11/16	6,800	
1 25/32	8,000	
1 7/8	8,400	
1 15/16	10,000	
2 1/16	10,400	
2 1/8	11,000	
2 1/4	12,500	
2 5/16	13,000	
2 1/2	16,000	
2 9/16	18,000	
3	19,200	
3 1/16	20,000	
3 3/8	24,000	
3 7/16	26,000	
4	33,400	

Common types of hooks are eye hooks, shank hooks, Clavis hooks, sister hooks, etc. Table 4.2-7 shows the hook throat opening versus the ratings for specific values.

4.2.12 Pins

Pins serve the primary purpose of retaining parts in a fixed position or preserving alignment. For pin diameter between 2 and 10 inches, use ASTM A-193, Identification Symbol B7, or AISI 4130 or SA 540 B-24 (4140) having a yield of about 130,000 psi.

Consider link connection to crane hook through an 8-inch pin.

Moment in pin: $361(5.56 + 1.25) = 2,459 \text{ in. -k}$

Try 8 in. pin SA-540 ID B-24 (4340) $F_y = 130,000 \text{ psi}$ Tensile strength = 145,000 psi

Failure will occur when full tensile occurs across the face of the pin. Mult. = 2 Pe

_ pin area = $4 \times 4 \times 3.16 / 2 = 25.12 \text{ in. sq.}$

$e = R - R(1 - 4/3 \times 3.14) = 1.7$

Mult. = $2(25.12 \times 145 \text{ ksi})1.7 = 12,370 \text{ in.-k}$

Mallow = Mult/5 = 2,474 in.-k > 2,459 in.-k

Shear; $F_v = 130 \text{ ksi} / (3)1/2 \times 1/5 = 15 \text{ ksi}$ Area of 8 in. pin = 50.24 in. sq

Allowable V = $50.24 \times 15 = 753 \text{ K} > 361 \text{ K}$

Pin Design for Link Connection

$M = 361 \times 4.06 = 1,466 \text{ in.-k}$

Try 7 in. pin SA 540 ID B-24 (AISI 4140)

Failure will occur when full tensile occurs across face of pin. Mult. = 2 Pe

_ pin area = $3.5 \times 3.5 \times 3.16/2 = 19.23 \text{ in. sq.}$

$e = R - R(1 - 4/3 \times 3.14) = 1.49$

Mult. = $2(19.23 \times 145 \text{ ksi})1.49 = 8,309 \text{ in.-k}$

Mallow = Mult/5 = 1,662 in.-k > 1,466 in.-k

Allowable V = $3.14 \times 3.5 \times 3.5 \times 15 = 577 \text{ K} > 361 \text{ K}$

Bearing = $361 / (7 \times 2.5) = 20.6 \text{ ksi}$

4.2.13 Shackles

Shackles are the primary devices that are used to attach slings to equipment lifting lugs. There are many specialized shackle designs. Figures 4.2-22, 4.2-23, and 4.2-24 present wide body, bolt type, and screw pin shackles.



Figure 4.2-22 Wide Body Shackle, Used for Synthetic Slings and Braided Slings



Figure 4.2-23 Bolt Type Shackle



Figure 4.2-24 Screw Pin Shackle

4.2.14 Load Attachment Devices

There are primarily three devices used to attach rigging to a load. They are: lift lugs, eyebolts and swivel eyes. Lift lugs constitute a broad category of load attachment devices. They are generally custom engineered and fabricated and include anything from welded plates with shackle holes to loops of rebar embedded in concrete.



4.2.15 Eye Bolts and Swivel Eyes

Eyebolts and swivel eyes are typically prefabricated devices that bolt or screw into bolt holes in the lifted equipment. They usually have light capacity and limited sideload capacity. The user must closely inspect the manufacturer's instructions to assure safe usage of these devices.

Figure 4.2-25 shows the typical sizes of eye bolts available. Figures 4.2-26 and 4.2-27 illustrate eyebolt loadings and swivel hoist rings.

Forged Machinery Eye Bolts

SHOULDER TYPE MACHINERY EYE BOLTS



S-279

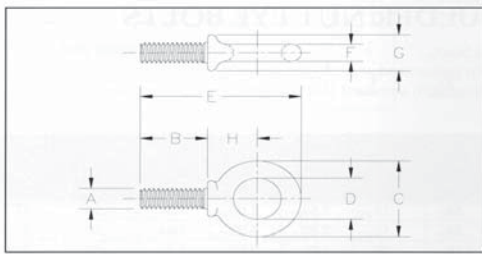

SEE APPLICATION AND WARNING INFORMATION
On Pages 90 - 91

- Forged Steel — Quenched & Tempered.
- Recommended for straight line pull.

Size	Stock No.	Working Load Limit * (lbs.)	Weight per 100 (lbs.)	Dimensions (in.)							
				A	B	C	D	E	F	G	H
1/4 x 1	9900182	650	3.20	.25	1.00	.88	.50	1.94	.19	.47	.50
5/16 x 1 1/8	9900191	1200	6.20	.31	1.13	1.12	.62	2.38	.25	.56	.69
3/8 x 1 1/4	9900208	1550	12.50	.38	1.25	1.38	.75	2.72	.31	.66	.78
1/2 x 1 1/2	9900217	2600	25.00	.50	1.50	1.75	1.00	3.38	.38	.91	1.00
5/8 x 1 3/4	9900226	5200	50.00	.63	1.75	2.25	1.25	4.19	.50	1.12	1.31
3/4 x 2	9900235	7200	87.50	.75	2.00	2.75	1.50	4.94	.62	1.38	1.56
7/8 x 2 1/4	9900244	10600	150.00	.88	2.25	3.25	1.75	5.72	.75	1.56	1.84
1 x 2 1/2	9900253	13300	218.00	1.00	2.50	3.75	2.00	6.47	.88	1.81	2.09
1 1/4 x 3	9900262	21000	380.00	1.25	3.00	4.50	2.50	7.72	1.00	2.28	2.47
1 1/2 x 3 1/2	9900271	24000	700.00	1.50	3.50	5.50	3.00	9.25	1.25	2.75	3.00

* Ultimate Load is 5 times the Working Load Limit.

Figure 4.2-25 Eye Bolts

FORGED EYE BOLT

WARNINGS AND APPLICATION INSTRUCTIONS

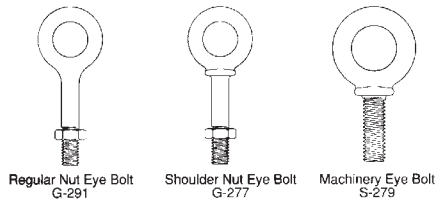

Important Safety Information — Read & Follow

Inspection/Maintenance Safety:

- Always inspect eye bolt before use.
- Never use eye bolt that shows signs of wear or damage.
- Never use eye bolt if eye or shank is bent or elongated.
- Always be sure threads on shank and receiving holes are clean.
- Never machine, grind, or cut eye bolt.

Assembly Safety:

- Never exceed load limits specified in Table I.
- Never use regular nut eye bolts for angular lifts.
- Always use shoulder nut eye bolts (or machinery eye bolts) for angular lifts.
- For angular lifts, adjust working load as follows:

Direction of Pull	Adjusted Working Load
45 degrees	30% of rated working load
90 degrees	25% of rated working load

- Never undercut eye bolt to seat shoulder against the load.
- Always countersink receiving hole or use washers to seat shoulder.
- Always screw eye bolt down completely for proper seating.
- Always tighten nuts securely against the load.

Size (in.)	Working Load Limit (lbs.)
1/4	650
5/16	1,200
3/8	1,550
1/2	2,600
5/8	5,200
3/4	7,200
7/8	10,600
1	13,300
1-1/4	21,000
1-1/2	24,000

Shoulder Nut Eye Bolt – Installation for Angular Loading

IN - LINE

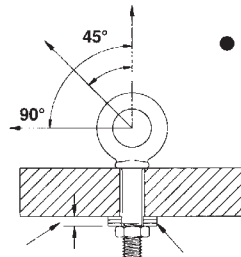

- The threaded shank must protrude through the load sufficiently to allow full engagement of the nut.

- If the eye bolt protrudes so far through the load that the nut cannot be tightened securely against the load, use properly sized washers to take up the excess space BETWEEN THE NUT AND THE LOAD.

- Thickness of spacers must exceed this distance between the bottom of the load and the last thread of the eye bolt.
- Place washers or spacers between nut and load so that when the nut is tightened securely, the shoulder is secured flush against the load surface.

Figure 4.2-26 Eye Bolt Loadings

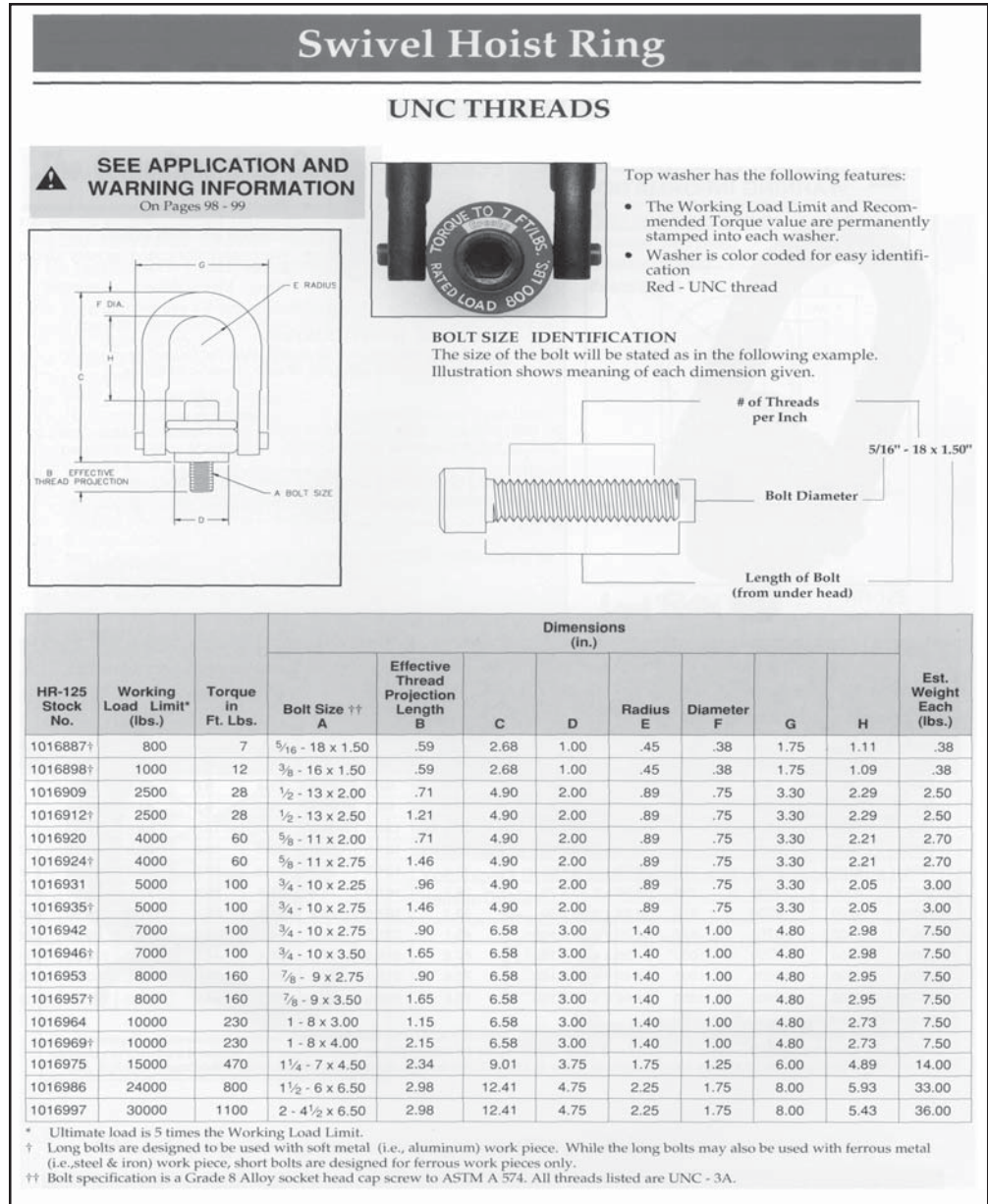

Figure 4.2-27 Swivel Hoist Rings

4.2.16 Design of Lifting Lugs

Normally, lifting lugs are designed by the equipment manufacturer; however, field staff at the jobsites may encounter the task of designing and fabricating lifting lugs for assembly and erection of equipment or components such as stacks, modules etc.

Lifting lug designs will be treated as pin connection members. The applicable portion will be the circular head of the eyebar. The diameter of the pin hole shall not be more than 1/32 inch greater than the diameter of the pin. Because installation and removal of a tightly positioned pin in the routine rigging work are difficult, the 1/32-inch required tolerance may not be practiced. Therefore, it would be prudent to provide sufficient safety factors in the design of the lug to account for bearing, tension, and shear stresses. In addition, consideration must be made in pin design to support bending moment and shear. For axially loaded lugs of steel alloys

Figure 4.2-28 shows three types.

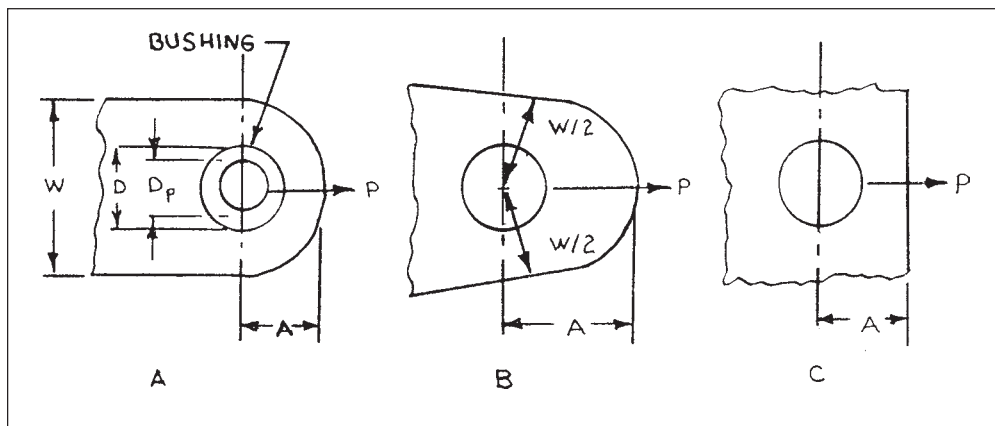

Figure 4.2-28 Lug-Pin Combinations Loaded Under Tension

The above axially loaded lift lug-pin combinations may fail because of tension failure, shear-bearing failure, and hoop tension failure. See Figure 4.2-29 for these three types of failure.

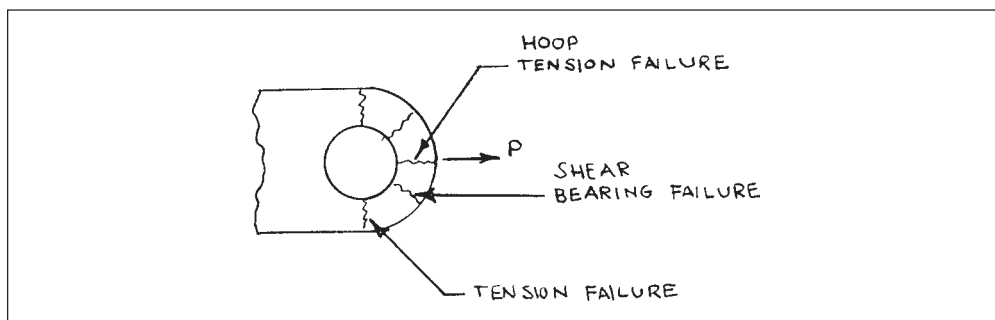

Figure 4.2-29 Three Types of Lug Failure

4.2.17 AISC Design Parameters for Tension Members

Tension members should be designed for unit stresses over the critical net section. The critical net section is considered the cross section area over which failure is likely to occur. The net section is obtained by adding the product of net width and thickness. The width of the body should not exceed eight times its thickness. The net section of the head through the pin hole should not exceed 1.33 and 1.50 times the cross sectional area of body. The pin hole diameter should not exceed the pin's diameter by more than 1/32 in. See Figures 4.2-30 and 4.2-31.

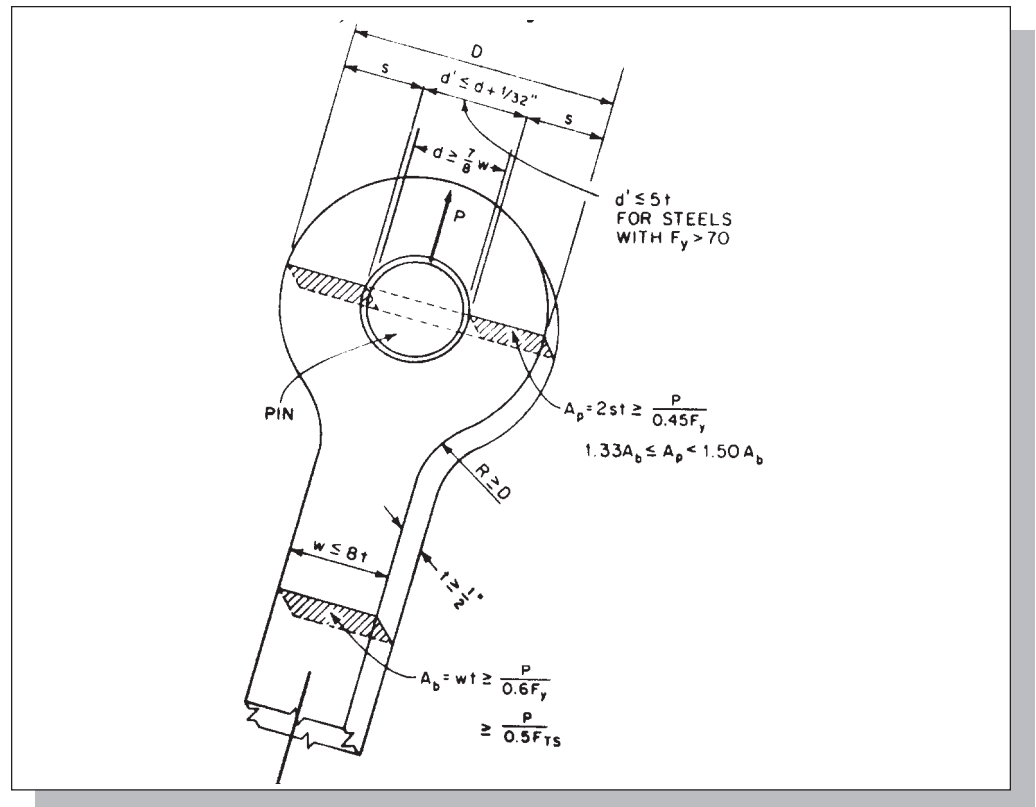

Figure 4.2-30 Dimensional Limitation for Eyebars

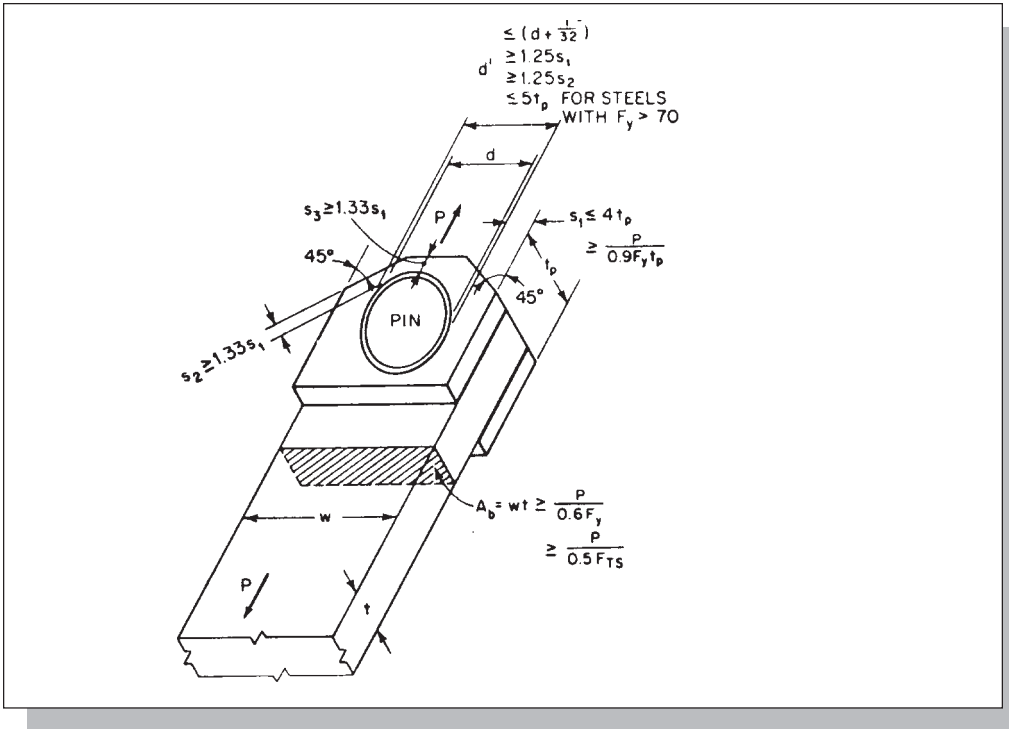
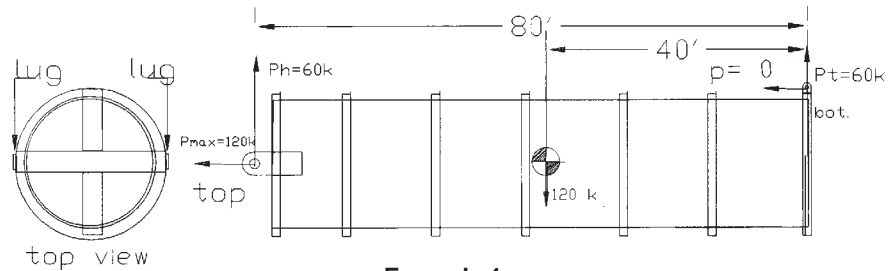

Figure 4.2-31 Dimensional Limitations for Builtup Pin Connected Members

For equipment installation that requires an up-ending operation, the lifting and tailing lugs will be subjected initially to horizontal loading (shear) and finally to vertical loading (tension). In addition, the lifting and tailing lugs will be subjected to combined shear and tension during the up-righting operation. The following example shows typical lift lug design procedures.

Example:

Design two lift lugs at the top to support the entire weight of a stack and one tailing lug at the bottom end of the stack. The stack is 10 feet in diameter, is 80 feet long, and weighs 60 tons. The center of gravity location is 40 feet from the tail lug. The stack fabricator's engineer has checked the stack's steel frame structure, and it can support the lifting and tailing lug local stresses. Use a spreader bar to prevent lateral forces to the lift lugs.

**Example 1***Lug Sample Problem*

Design load for the top lugs: load + 25% impact = 75 ton

Using two lift lugs at top and one tailing lug.

Design load for each lift lug at top: $P_{max} = 75$ kip

Design load for one tail lug: $P_t = 75$ kip

Design lifting lugs to accommodate 55 ton Crosby shackle.

Design tailing lug to accommodate 55 ton Crosby shackle.

Minimum plate thickness required:

$$A \text{ pin bearing} \geq P / F_p$$

$$P = 75 \text{ ton or } 75 \text{ kip per lifting lug}$$

$$F_p = .9 F_y \text{ for A-36 } F_p = 32.4 \text{ ksi}$$

$$A = 75k / 32.4 \text{ ksi} = 2.31 \text{ in.}^2$$

$$\text{for } 55 \text{ ton Crosby, shackle pin dia.} = 2.75 \text{ in.}$$

$$t_{min.} = A / \text{dia} = 2.31 / 2.75 = 0.84 \text{ in.}$$

Use 1 inch plate A-36 material.

Example 2
Lug Dimensions

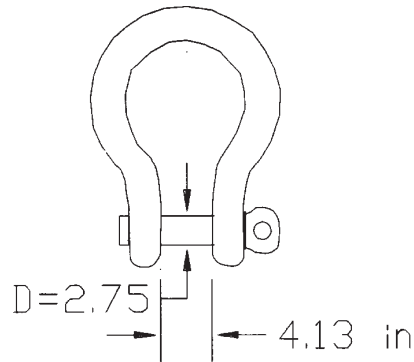

55 ton screw pin Crosby Shackle

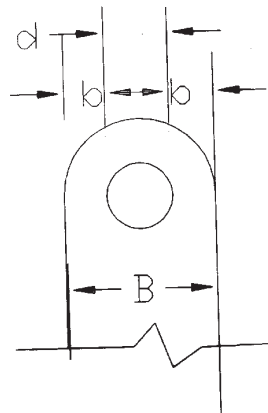

Minimum plate width required:

$$b \geq \text{or} = .8d \text{ (pin dia.} + 1/32) = (2.75 + 1/32) \times .8 = 2.25 \text{ in.}$$

$$\text{Min. plate width req.} = 2 \times b + d = 2 \times 2.25 + 2.78 = 7.28 \text{ in.}$$

Use 8 inch plate A-36 for width. Lift lug plate dimension = 1 in. x 8 in.

Minimum area required across the pin hole > or = P/1.45:

$$F_y = 75 \text{ k}/16.2 \text{ ksi} = 4.63 \text{ in.}^2$$

$$\text{Net cross section area furnished; } t(B-d) = 1(8 - 2.78) = 5.22 \text{ in.}^2 \text{ ok}$$

Minimum area required beyond the pin hole = or > 2/3 net cross section at pin hole

$$A \text{ net beyond} = 2/3 (A \text{ net req.}) = 2/3(4.63) = 3.08 \text{ in.}^2 \text{ required}$$

$$\text{Have: } A = t(B/2 - d/2) = 1(4 - 1.39) = 2.61 \text{ in.}^2, \text{ N. G. Try } 1 \frac{1}{4} \text{ in. plate}$$

$$1.25(4 - 1.39)$$

$$= 3.26 \text{ ok.}$$

Use 1 1/4 in. thick plate.

Example continued:**Minimum weld size for attachment:**

Although a spreader bar will be used, consider 10% accidental side load.

Consider 12 inch length of weld beyond top of the vessel as shown: $L = 2 \times 12 = 24$ in.

Treat weld as a line of unit width and locate N. A. $x = 6$ in. and $y = 4$ in. $b = 12$ in. $d = 8$ in.

$$S_{xx} \text{ (section mod. for unit width)} = bd = (8 \times 12) = 108 \text{ in.}^3$$

$$I_p \text{ (polar mom. inertia)} = 1/6 (b)(3d^2 + b^2)$$

$$I_p = 1/6(12) (3 \times 8 \times 8 + 12 \times 12) = 672 \text{ in.}^4$$

Max. stress at point A is the resultant of direct and twisting stresses.

Max. stress at point B is the resultant of direct, twisting, and bending stresses.

Stress at point B is greater than point A.

Bending stress due to side load of 10%:

$$f = M / S_{xx} \quad M = Pe = 7.5 \text{ k}(4+6) = 7.5 \text{ k-in.}$$

$$f = 75 / 108 = 0.69 \text{ k per lin. in.}$$

Direct stress due to Ph (upending load 75/2):

$$Fd = Ph/l = 37.5 \text{ k} / 24 \text{ in.} = 1.56 \text{ k/lin. in.}$$

Twisting stress due to eccentric lug loading:

$$\text{horz. } Ft = Mx/l = 75 \times 6 / 672 = 0.67 \text{ k/ lin. in.}$$

$$\text{vert. } Ft = My/l = 75 \times 4 / 672 = 0.44 \text{ k/ lin. in.}$$

Resultant stresses at B:

$$Ft^2 = 0.44^2 + (1.56 + 0.67)^2 \quad Ft = 2.27 \text{ k/lin. in.}$$

Weld force when load is vertical:

$$Fw = P/L \text{ or } 75 \text{ k} / 24 \text{ in.} = 3.125 \text{ k/lin. in.} > 2.27 \text{ k/lin. in.}$$

Weld size:

$$\text{Max. stress} / .27 \times 70 \times .707$$

Example 3

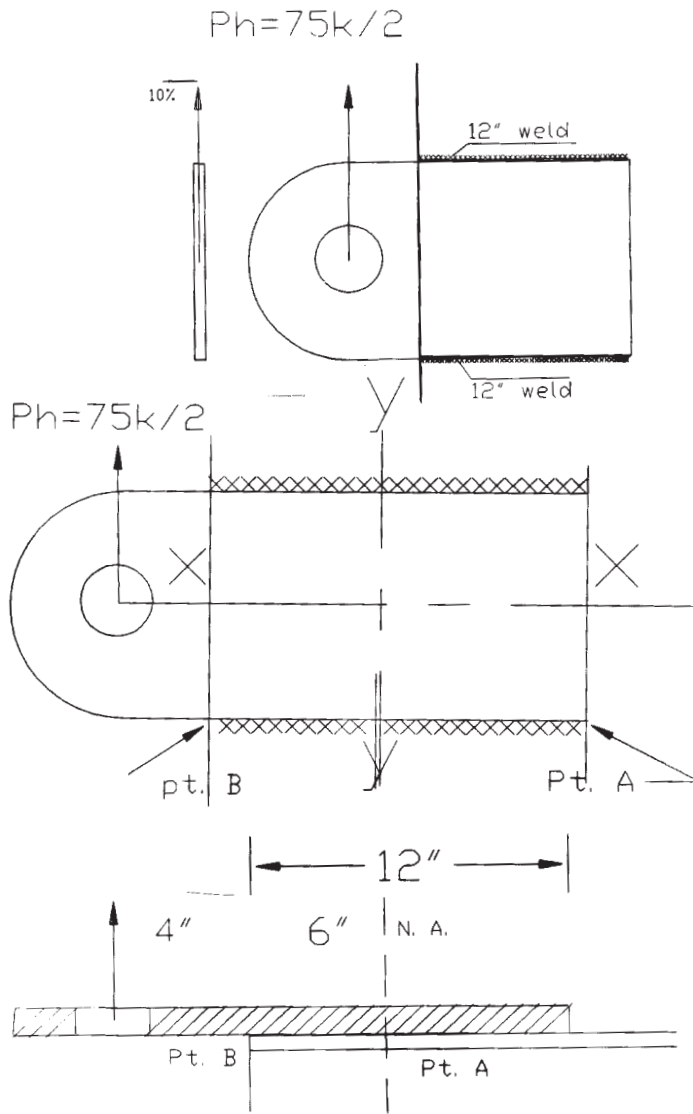

$.125 / 13.36 = .28 \text{ in.}$

Use 3/8 in. fillet weld.

Example 4*Tailing Lug***Tailing Lug Design:**

Design tailing lug to accommodate 55-ton shackle having pin diameter of 2.75 in.:

Max. tailing load = 75 kips

Minimum plate thickness required:

A pin bearing = or $> P/F_p = 75/9 F_y = 2.31 \text{ in.}^2$

Pl. thickness min. = $A/\text{pin dia.} = 2.31/2.75 = .84 \text{ in.}$

Use 1 1/4 in. thick plate A-36 materials.

Minimum plate width required:

$b = \text{or } > .8d = 2.2 \text{ in.}$

$B \text{ min.} = 2b + d = 2 \times 2.2 + (2.75 + 1/32) = 7.18$

Use 8 in. wide plate.

Minimum area across the pin hole required:

A net cross = or $> P/v/.45F_y = 75/16.2 = 4.63 \text{ in.}^2$

Have: $(8 - 2.78) \times 1.25 = 6.525 \text{ in.}^2$

Minimum area beyond the pin hole required:

A net beyond = or $> 2/3 (A \text{ net cross}) = 2/3 \times 4.63 = 3.08$

Have: $(8/2 - 2.78/2) \times 1.25 = 3.26 \text{ ok}$

Size weld: $L = 2(8 + 1.25) = 18.5 \text{ in.}$

$f_w = P/L = 75/18.5 = 4.05 \text{ k/lin. in.}$

$w = f_w/.27 \times .707 \times 70 \text{ ksi} = 4.05/13.4 = 0.30 \text{ in.}$

min. fillet weld 5/16 in.

Use 1/2 in. fillet weld all around to weld tail lug to the base.

Plate (10 in. x 6 in. x 1 1/4 in.) and baseplate to the stack shell.

Tail lug will position on top directly under vertical internal bracing (spider).

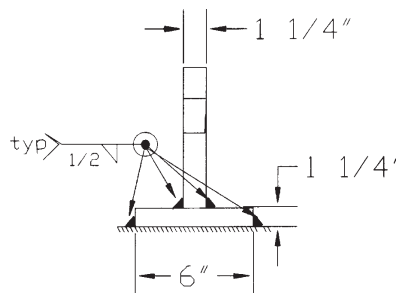

Tailing Lug

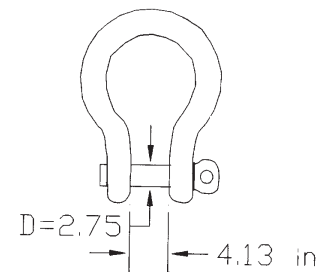

55 ton screw pin Crosby Shackle

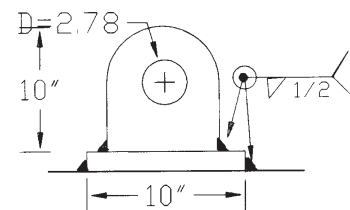

5

SPECIAL LIFTING METHODS



5. Special Lifting Methods

5.1 INTRODUCTION

This section deals with a group of specialized lifting devices and systems that are in common use on jobsites and within the rigging industry. Topics include the jacking and cribbing operation, hydraulic gantries, pole lift systems, strand jack systems, and rod jack systems.

5.2 JACKING AND CRIBBING

The oldest and most rudimentary method for lifting and setting equipment and machinery is the jack and crib method. It is conceivable that this was the method used to construct the pyramids of Central America and Egypt. The method consists simply of raising one end of a load (a stone or piece of machinery) a small distance with a jack or lever, then stuffing some cribbing blocks under that end. The jacks or levers are then removed and moved to the opposite side, which is lifted and cribbed. This procedure continues, alternating from side to side, until the crib pile is built to the desired height. Once it has reached its desired height, the load can be slid or rolled off the pile to its intended destination.

Jacking and cribbing is still common on today's construction sites because it offers the advantage of requiring no expensive equipment other than a set of jacks and an ample quantity of cribbing material. It is, however, a time-consuming and labor-intensive procedure. Do not be misled by the simplicity of the method. Jacking and cribbing requires a skilled labor force to sequence the jacking procedure and to build safe crib piles. A knowledgeable rigging engineer must design the cribbing piles and supporting foundation to ensure that it is suitable for the required jacking operation. Generally, the cribbing is made of wood. Hardwood cribbing such as oak is preferred over softwood cribbing such as Douglas fir because of its higher compressive strength. All wood cribbing should be in new or like-new condition with no dry rot or splits.

The size of the jack selected for use will, of course, depend on the weight of the load. It is recommended that the jack be selected so that the load to be lifted by the jack is not more than 75 percent of the jack's rated capacity. For example, if it is desired to lift 75 tons per jack, use a jack of not less than 100-ton capacity. Usually, hydraulic jacks, also commonly referred to as hydraulic cylinders, are used over lever-operated mechanical jacks. They come in capacities ranging from 1 ton to more than 800 tons, with maximum operating hydraulic pressures of 3,000 to 10,000 pounds per square inch (psi). Jacks with a maximum hydraulic pressure of 10,000 psi are the most common. The hydraulic jack or cylinder consists of a hollow cylinder body and a piston that moves inside the body.

The height of each cribbing layer depends on the stroke of the piston. For this type of operation, the cylinder stroke typically ranges from 6 to 12 inches. The smaller cylinders can be operated with

hydraulic hand pumps, but the larger cylinders require a hydraulic power unit because of the large quantities of oil required. Construction time and stability of the crib pile are the only limitations on the final lift height.

Once the final lift height is achieved, rollers or skids may be placed under the load to move it off the crib pile. Typically, a steel runway is slid under the load to facilitate rolling or skidding. Machinery rollers produced by manufacturers such as Hilman or Multi-Ton are preferable to skidding the load because much less force is required to move the load. If skidding is to be performed, the force required can be reduced by using lubricants such as grease, dry graphite spray, or silicon. Skidding can also be performed using low-friction materials such as Teflon or UHMW on the skidding surfaces.

Jacking operations require a check of the foundation against which the operators are jacking. A firm base consisting of steel plates or wood mats is typically required so that the jacking force does not damage the foundation. A piece of equipment should only be jacked at locations approved by the equipment manufacturer. Typically, manufacturers of heavy equipment provide jacking lugs or flat-bottomed trunnions on which to jack. These same precautions also apply to cribbing and roller placement. Always set the first layer of cribbing on a solid, level surface. A rigging engineer must check the bearing pressure under the cribbing. Place cribbing and rollers only at approved support points (foot pads) under the equipment being lifted. Otherwise, the equipment may be damaged.

5.2.1 Detailed Jacking and Cribbing Procedures

The first step in the jacking and cribbing procedure is to set up a safe jacking arrangement. This arrangement consists of two cribbing piles and two identical, **hydraulically interconnected** (hydraulically interconnected jacks are jacks that share a common hydraulic supply line from a single hydraulic manifold and pumping unit in a configuration so that the lifting pressure in both jacks is always equal) jacks placed at one end of the piece of equipment at the manufacturer-approved equipment support points. The cribbing piles at the jacking end provide safety in the event that the hydraulic jacks fail to support the load. These piles will also support the load when the jacks are not used or removed. The **other end of the equipment rests hard on cribbing** to provide stability. This is very important because it prevents the load from rolling during jacking. This arrangement provides predictable loads in the jacks and at the cribbing points and prevents two-pointing. During the jacking operation, the cribbing piles adjacent to the jacks should be continuously shimmed to minimize the distance that the load will settle in the event that a jack fails.

The next step is to extend the two interconnected jacks high enough to install the cribbing layer. The jacks will extend equally because the opposite end is resting hard against its cribbing. Install the layer of cribbing under the jacked end. Shim the cribbing tight with steel shims or hardwood.

Next, slowly release the pressure in both jacks using a common needle type valve. This method will allow the jacks to slowly retract and gradually load the cribbing pile. Because the cribbing is shimmed tight, the load will not move downward other than to slightly compress the cribbing pile and shims. However, the load should be lowered slowly while watching the cribbing pile to ensure that the cribbing is adequately holding the load. Repeat this jacking and cribbing procedure at this end.

As stated before, the stroke of the jack determines the height of each cribbing layer. However, the height must not be so excessive that the jacks tip over and “shoot out.” Jacking up to a one-or two-degree tilt angle is reasonable. With this in mind, the jack tops must be equipped with swivel bearings (tilt saddles) to allow for this tilt.

Another word of caution, “**never place metal against metal.**” Use a thin piece of wood or plywood to increase friction between the jacking point and the top of the jack. This approach will reduce any chance of the jack slipping and will also improve load spreading and prevent point loading of the jack’s piston and cylinder housing. Following the above procedures will result in a safe jacking and cribbing operation.

Consider the consequences of not following the proper procedures:

- If **four hydraulically interconnected** jacks are used, one at each corner, there is the possibility of the load rolling. If the jacks are not all placed symmetrically about the center of gravity of the equipment, the jack with the lightest load will extend quicker than the others (Pascal’s Law). The load will then tilt or roll unpredictably.
- If **four independent** jacks are used, there is no way of controlling them so that they all extend at the same rate. Consequently, the load will two-point diagonally on the two highest jacks. This could possibly overload those two jacks or damage the equipment.
- If **one end is hard cribbed** and the **two independent jacks** are used at the other end, two-pointing may occur.
- If a thin piece of wood is not used between metal surfaces, the jack could slip out or the jack piston or cylinder housing could be point loaded and damaged.

5.3 JACKS — HYDRAULIC CYLINDERS

Although other mechanical types of jacks are available and sometimes used, our discussion is limited to hydraulic cylinders. Although “hydraulic cylinder” is the modern terminology used by manufacturers, the same lifting device may also be referred to as a “jack,” “hydraulic jack,” “ram,”

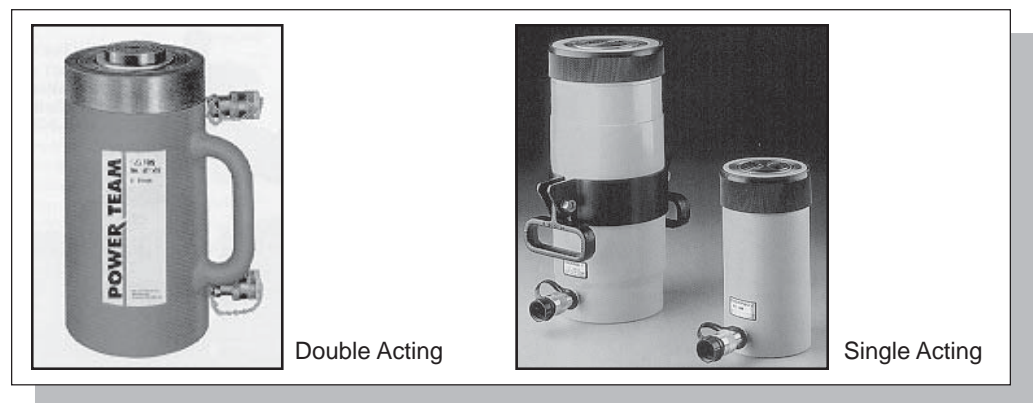

Figure 5.3-1 Double-Acting and Single-Acting Cylinders

or “hydraulic ram.” Hydraulic cylinders are most commonly used for rigging because of their compact size and ease of operation. A variety of hydraulic cylinders are available. They are generally specified by stroke, capacity, and action (single or double). The piston diameter and pressure rating of the seals primarily determine the capacity of the hydraulic cylinder.

The available action types are either double acting or single acting. A double-acting cylinder has a port to hydraulically retract the piston. An external force to the piston is required to retract a single-acting cylinder, although most are available with internal retraction springs. A double-acting cylinder is more versatile and generally only slightly more expensive than an equivalent single-acting cylinder. The retraction capacity of a double-acting cylinder is usually much less than its extending capacity because there is less surface area for the pressure to act on.

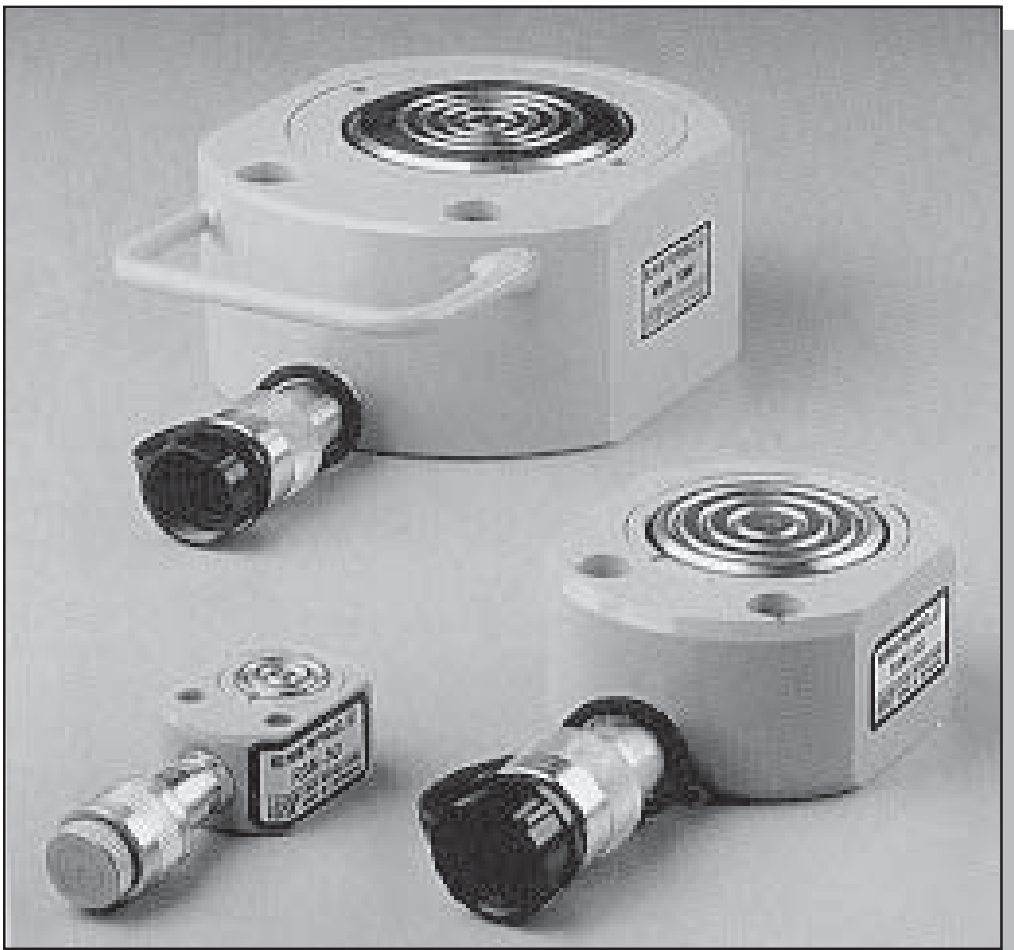

Figure 5.3-2 Assortment of Low-Profile, Single-Acting Cylinders

Several special types of hydraulic cylinders are commonly used in rigging operations. A center hole cylinder, as its name implies, consists of a cylinder whose center is open similar to a pipe.

This allows a rod or cable to pass through the center of the cylinder. As will be discussed in a later section, this type of cylinder is used for strand lift systems. Locking collar or lock nut jacks have a threaded collar that is part of the jack's piston. When the collar is tightened down, the jacking pressure can be released and the jack's steel structure will support the entire load without fluid pressure. These jacks are generally single acting and are commonly available in lighter, aluminum models. Flat jacks consist of a deformable steel bladder with bearing plates on the top and bottom. They have a total height of 1 to 2 inches and have a stroke of about 1 inch. They have an extremely high capacity and can be used to raise and level building columns and heavy machinery. Flat jacks can be pumped full of grout and left in place permanently.

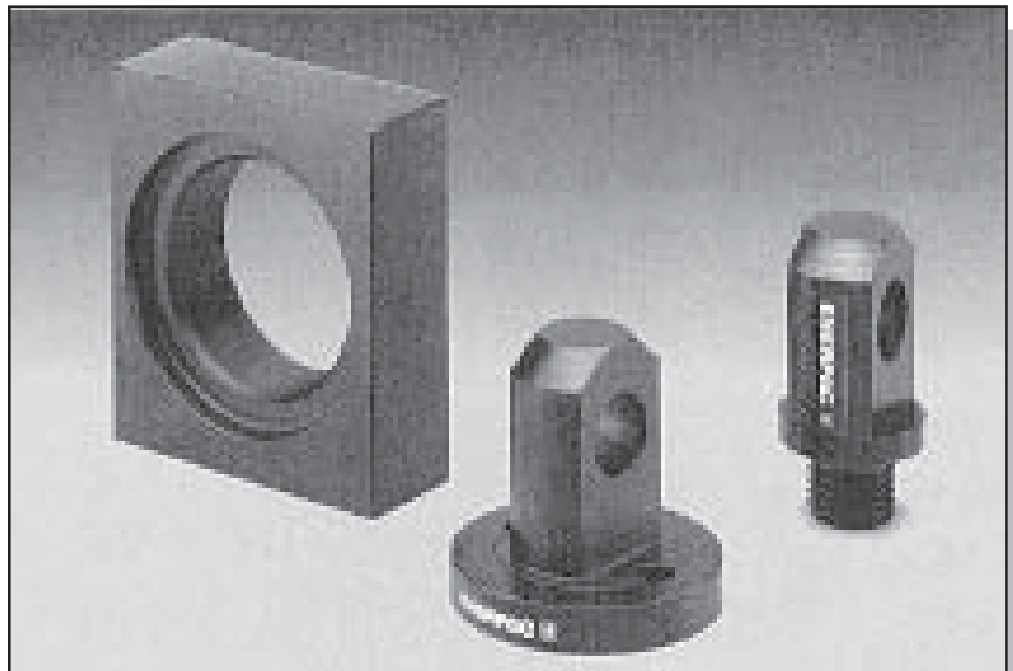

Figure 5.3-3 End Fittings

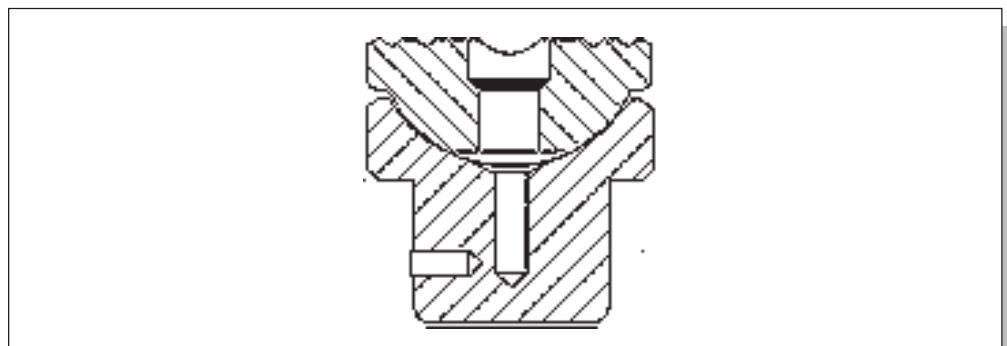

Figure 5.3-4 Tilt Saddle

Hydraulic cylinders are available with a variety of end attachments. These attachments usually screw onto threads at the end of the piston or the base of the cylinder housing. Attachments include clevises, lugs, tilt saddles, or spherical bearings. These fixtures facilitate attachment to the load and ensure that the cylinder is loaded concentrically. Clevises, lugs, and spherical bearings allow the cylinders to be pinned to the load.

5.4 HYDRAULIC PUMPS

Hand pumps are commonly used to operate small jacks. They usually have a 1- or 2-gallon oil reservoir and operate up to 10,000 psi. For larger jobs, portable electric-powered pumps are available. They have reservoirs up to about 20 gallons. For very big jobs, large skid-mounted pumps are used. They are typically diesel operated and have large oil reservoirs.

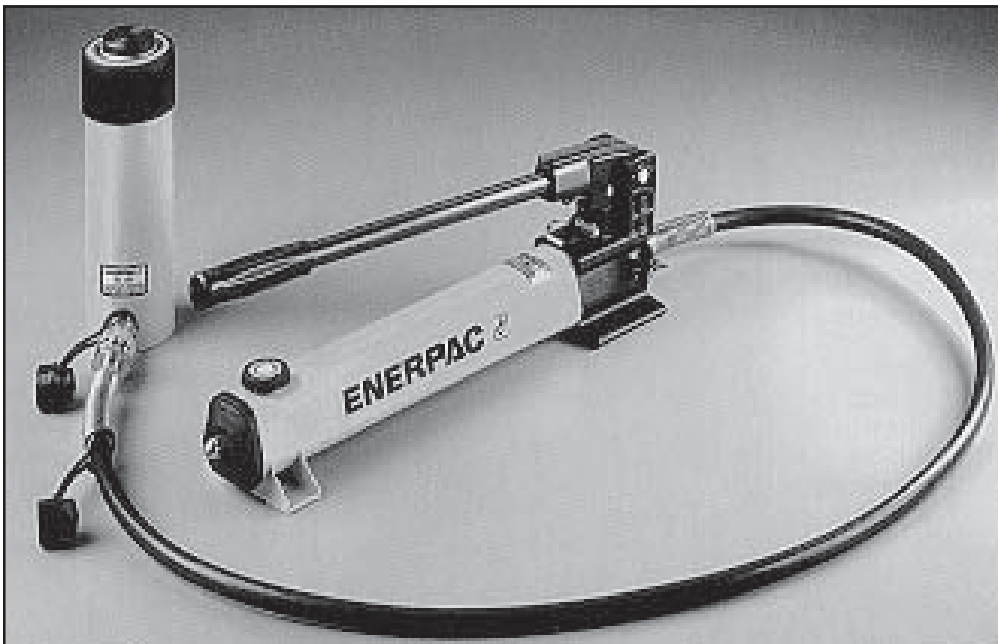

Figure 5.4-1 Hydraulic Hand Pump and Cylinder

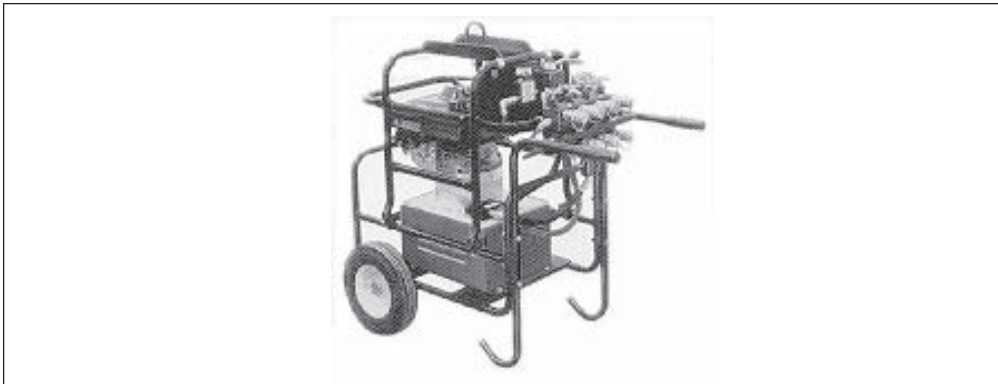

Figure 5.4-2 Cart-Mounted Hydraulic Pump

5.5 ROLLERS

A variety of different rollers are available. The types commonly used in heavy rigging situations are the wide flat types such as rollers manufactured by Multi-Ton or Hilman. Hilman rollers incorporate the chain-linked tread design. This design provides a low degree of rolling resistance, while making it easy for the roller to negotiate anomalies in the rolling surface. Rollers run best on smooth steel surfaces such as plates or rail beams. Rollers can be used directly on concrete floors for light loads only. Heavier loads require rails or plates. Guides are required to direct the load in the proper direction. Guides can consist of inverted channels, flat bars, or cams. When using channels, leave sufficient clearance between the channel flanges and the jack body to prevent binding. Cam guides do not necessarily require channels and will minimize binding. They attach to the roller and resemble outriggers. The cams catch the edge of the rail beam flange to guide the roller. Custom rollers are also available and are fabricated so that they move in a circular path.

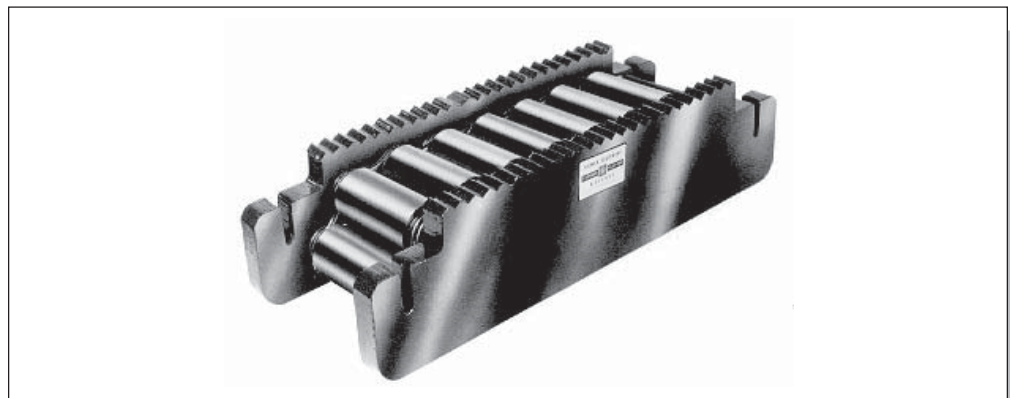

Figure 5.5-1 Hilman Roller

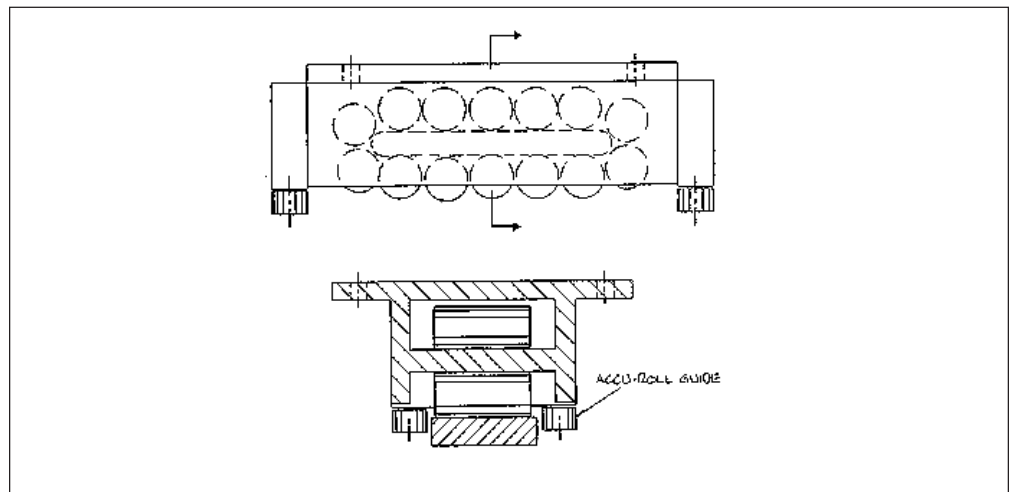

Figure 5.5-2 Hilman Roller with Guide Cam

LIFT BEAM LOAD CHART WITH 1402-2-39 GANTRY																						
BETCHEL ONE (1) LIFT BEAM TWO (2) LIFT LEGS FIRST STAGE MAX. LOAD PER LEG (2,000 LBS PER TON) 175 U.S. TONS!		SIZE 27.0 in WEIGHT/ FOOT 368.0 Lbs/Ft SECT. MODULUS 1060.0 in³ MATERIAL YIELD 50,000 P.S.I.	BEAM LENGTH 40.0 Feet BEAM WEIGHT 7.36 Tons LIFT CENTERS 36.0 Feet SAFETY FACTOR 2.2 to 1¹	J & R ENGINEERING CO., INC. NOVEMBER 4, 2000 COPYRIGHT 2000 *ALL RIGHTS RESERVE!																		
THE BEAM WEIGHT IS DEDUCTED. WEIGHT OF ADDITIONAL RIGGING MUST BE DEDUCTED. WHEN USING FOUR LIFT LEGS AND FOUR LIFTING PLACES CONSIDERATION MUST BE GIVEN TO THE POSSIBILITY OF ONLY TWO OF THE FOUR LIFTING PLACES ARE LIFTING THE LOAD AND DOUBLING THE LOAD ON THE BEAM AND RIGGING.																						
DIST A IN FT	MAX. HEIGHT 31' 6"	DISTANCE B IN FEET								ALL CAPACITIES LIMITED BY GANTRY CAPACITY ALL CAPACITIES LIMITED BY BEAM STRENGTH BEAM DIMENSIONS HEIGHT 30.39 WIDTH 14.66 FLANGE 2.48 WEB 1.38 BEAM STRUCTURAL RATING!												
		3.0	4.0	5.0	6.0	7.0	8.0	9.0	10.0				12.0	14.0	16.0	18.0						
3.0	342.04	175.00																				
4.0	333.38	342.64	175.00																			
5.0	324.61	333.38	342.64	175.00																		
6.0	316.28	324.61	333.38	342.64	175.00																	
7.0	308.38	302.55	293.65	285.26	277.33																	
8.0	281.81	273.00	284.73	256.94	249.60	242.87																
9.0	258.84	250.48	242.87	235.31	228.39	221.87	215.70															
10.0	240.98	232.98	225.45	218.40	211.78	205.58	199.88	194.13														
12.0	215.70	208.00	200.83	194.13	187.87	182.00	176.48	171.28	161.78													
14.0	199.68	192.00	184.88	178.28	172.14	166.40	161.03	156.00	146.82	138.67												
16.0	189.91	182.00	174.72	168.00	161.78	156.00	150.82	145.60	136.50	128.47	121.33											
18.0	184.88	176.48	168.81	161.78	155.31	149.33	143.80	138.87	129.42	121.33	114.20	107.85										
20.0	183.94	174.72	166.40	158.84	151.83	145.80	139.78	134.40	124.80	116.48	109.20	64.35										
22.0	186.87	176.48	167.20	158.84	151.27	144.40	138.12	132.38	122.18	113.45												
24.0	194.13	182.00	171.28	161.78	153.28	145.60	138.87	132.38	121.33													
26.0	206.77	192.00	179.20	168.00	158.12	149.33	141.47	134.40														
27.0	205.58	199.11	184.88	172.56	161.78	152.28	143.80															
28.0	202.21	205.58	192.00	179.28	168.40	158.00	150.00															
29.0	198.94	202.21	200.83	185.38	172.14																	
30.0	195.78	198.95	202.21	194.13																		
31.0	192.74	195.78	198.95																			
32.0	189.77	192.74																				
33.0	186.88																					

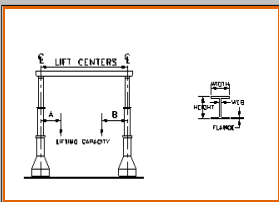

Figure 5.5-3 Lift Beam Load Chart

5.6 HYDRAULIC GANTRIES

These jacking devices consist of two or more jack base units and one or more header beams with devices for rigging attachment. Each jack base unit has one or more multiple-stage hydraulic cylinders housed within a steel base with wheels at each corner. The jack's base units are used in pairs and are spanned at the top by a header beam. The load is rigged to and hangs from the header beam. Link plates facilitate attachment of the rigging to the header beam. Link plates are steel plates with a large square opening and a shackle hole near the bottom. The jack base units must be set up on a suitable, level runway or track made up of steel beams, steel plate, or a combination of the two materials. For lift and roll operations, the runway should have suitable guides to maintain proper alignment and control of the jacking system. Once lifted, the load can be transported along the runway with hydraulic propel jacks or hydraulic propel wheels. Hydraulic gantries have lifting capacities up to 1,800 tons or more and lifting heights of more than 40 feet.

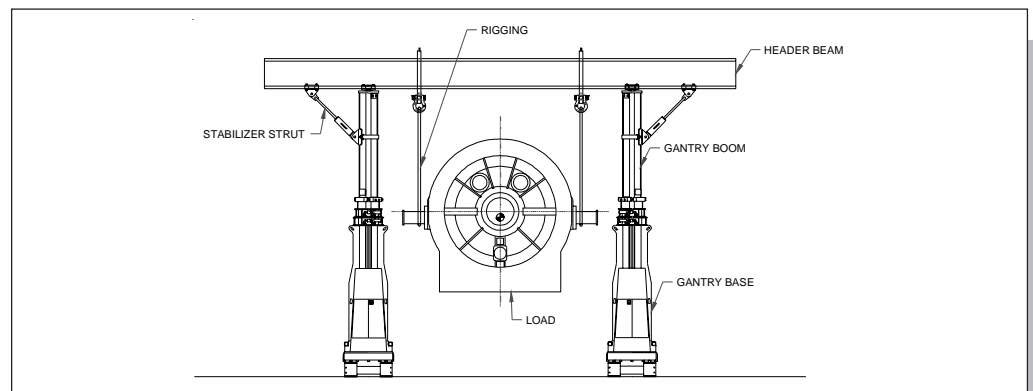

Figure 5.6-1 Hydraulic Gantry Components

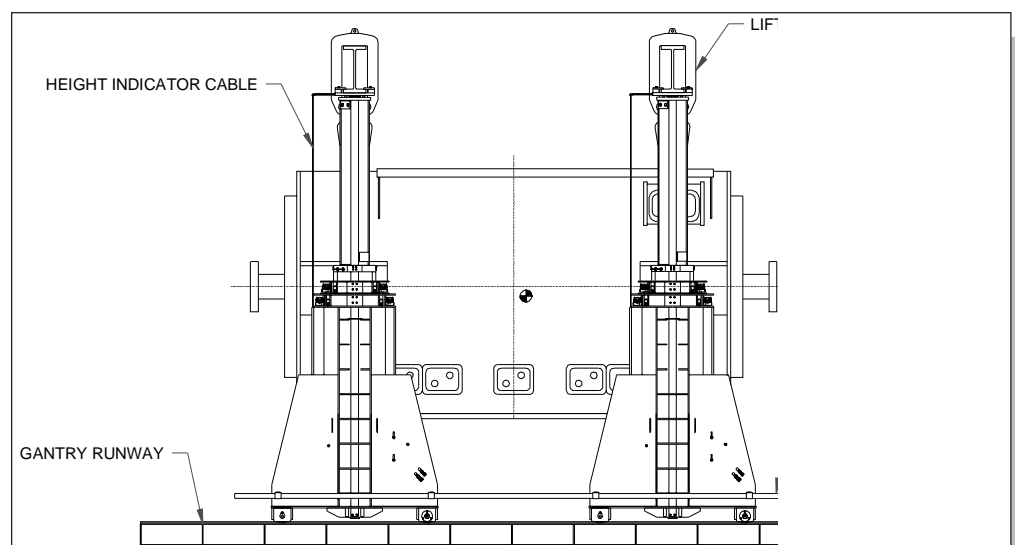

Figure 5.6-2 Two Hydraulic Gantries Hitched Together

Hydraulic gantries have the advantage of requiring very little headroom clearance, making them ideal for indoor use. If two pairs of jacks are used, they work well to up-end or lay down machinery and equipment. While these gantries originally were used for setting presses, mill machinery, generators, turbines, and similar heavy equipment, they have rapidly found their way onto construction sites. In this arena, they work well for offloading, transloading, or setting a wide variety of plant equipment such as heat exchangers, tanks, refinery vessels, generators, transformers, etc. The large lift capacity and relatively quick setup time compete favorably with large capacity cranes for offloading and transloading. For example, the system can be set up to span over a load on a rail car. The load is then rigged and lifted vertically from the deck of the rail car. The rail car is then pushed away and a tractor trailer is backed in under the load, which is then lowered onto the trailer and hauled away. For transloading equipment in the 250 to 800 ton range, the jacking system is an economic alternative to using cranes.

Currently, manufacturers are producing two different varieties of hydraulic gantry base units — the bare cylinder type and the telescopic steel boom type. The bare cylinder type consists of a telescopic hydraulic cylinder mounted to a steel base with wheels at each corner. In the steel boom type, the telescopic cylinder is mounted within a telescoping structural box boom. This type resembles a hydraulic crane boom. The purpose of the box boom is to provide a means for positively locking the boom — with pins or other devices — while the loaded system is being rolled or the load is being held for a period of time. This allows the load to be held by the jack base boom structure and not the hydraulic fluid pressure within the cylinder. The steel boom also serves to resist any lateral load independent of the hydraulic cylinder. In the bare boom type, a lateral load is taken directly by the pistons.



Figure 5.6-3 Pair of Hydraulic Gantries with Header

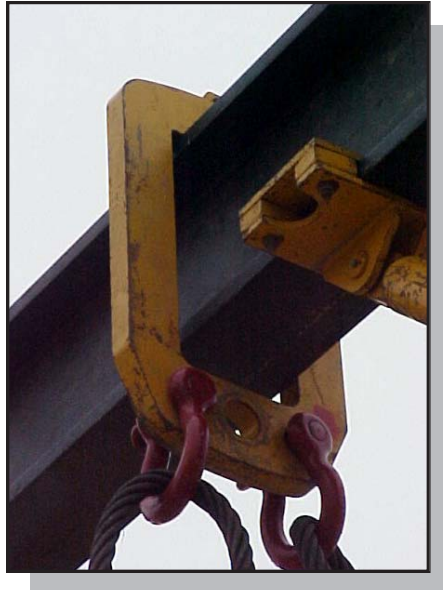

Figure 5.6-4 Typical Link Plate

5.6.1 Lift Planning with Hydraulic Gantries

Before planning or executing a lift with a hydraulic gantry system, the lift planner and operators should attend the manufacturer's training program. They should also thoroughly review the gantry manufacturer's operation manual and the document "Recommended Practices for Hydraulic Jacking Systems" available through the Special Carriers and Rigging Association.

The planner must first determine if the job will require one pair or two pairs of jack bases. This decision is dictated by the weight of the load and the arrangement of the approved lift points. Next, the lift location and set location must be determined. This will dictate the jack locations, header beam length requirements, and runway locations. When the runway is placed, attention must be given to obstacles on the ground such as pedestals, footings, building columns, rebar, conduit, pits, anchor bolts, and so forth. The runway must be leveled in accordance with the gantry manufacturer's recommendations. Clearance of the jack base units, header beam, and rigging to overhead obstacles should also be considered. Overhead, the top of the gantry must clear roof trusses, beams, ductwork, and most important, bridge cranes. Overhead bridge cranes are a potential menace to hydraulic gantries. These cranes **MUST** temporarily be taken out of operation when working within their territory. There have been instances when bridge crane operators have run into and tipped over the extended hydraulic gantries.

For attaching rigging to the equipment being lifted, link plates are generally positioned on the header beam directly above the lift points. A rigging engineer, familiar with hydraulic gantry system design and operations, must evaluate the header beams, runways, rigging, support foundations, and procedures when planning hydraulic gantry work. Because of the variety of

possible loading conditions, pre-engineered header beams are not available, and each situation must be evaluated individually. The hydraulic gantry runways are generally set up on a solid, level base such as wooden mats or concrete. The runway beams ideally should be supported continuously along their length. However, the beams are typically pre-engineered to span short distances between support or shim points. Long spans are possible with specifically designed runway girders. Regardless of the span, an engineer must check the adequacy of the soil, concrete base, or other structures on which the runways are ultimately resting.



Figure 5.6-5 Hydraulic Gantry Lift

When hydraulic gantries are operated outdoors, the effects of wind during loading should be considered. It will often be found, however, that the wind's effect is insignificant because of the large weight and relatively small sail area of the items typically being lifted by these systems.

To side-shift means the ability of a gantry to move a load in a direction perpendicular to its runway. Hydraulic gantries do not have built-in side-shift capabilities. There are several ways around this problem. Small amounts of equipment side-shifting (1 to 2 inches) are normally required to set a piece of equipment on its anchor bolts because the pick location is normally not precisely in line with the final set location. To accommodate this condition, the most common and accepted practice is to use chain come-alongs or wire rope grip hoists at each corner of the lifted equipment to drift the equipment into place while it is being lowered. This practice is normally sufficient to align the equipment with its anchor bolts. A qualified rigging engineer should plan and supervise such an operation. The second side-shift option is to mount hydraulic rams or a hydraulic side-shift device on the header beam and push the link plates over in the required direction. The link plates normally bear directly on the top flange of the header beam. For a side-shift operation, the link plates are mounted on some type of rollers. The ram or side-shift device actually pushes the roller or slide on which the link plate rests. This type of system must be restrained against accidental sideways movement. Another side-shift option, if space permits, is to actually disassemble the complete hydraulic gantry system and set it up in the desired direction of travel. This method is time consuming and frequently involves significant rigging changes. Therefore, if possible, it should be avoided.



Figure 5.6-6 J & R Engineering Power Link

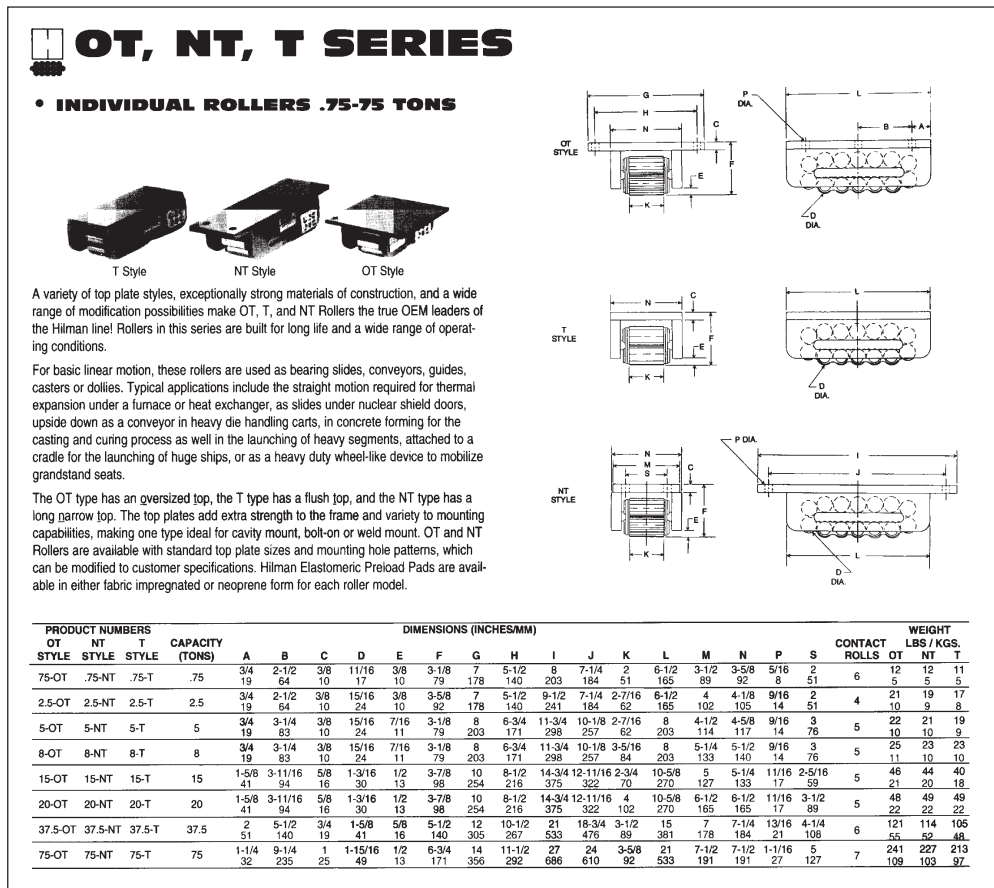

Figure 5.6-7 Hilman Roller Data

5.7 POLE LIFT SYSTEMS

Pole lift systems are a traditional method of erecting, in one piece, very tall, heavy vessels such as refinery columns. Availability of large, high-capacity cranes has diminished the use of poles. They are still used because they are inexpensive to purchase and can be used in areas where a crane will not fit. Many pole systems are available worldwide, but it is unlikely that any two are identical. No design standards exist for the pole system. Each set is engineered and built for a specific application or type of application. The pole system is then modified, if necessary, and used for the next job. American Hoist and RMS of Sweden are perhaps the only manufacturers that make somewhat standardized systems.

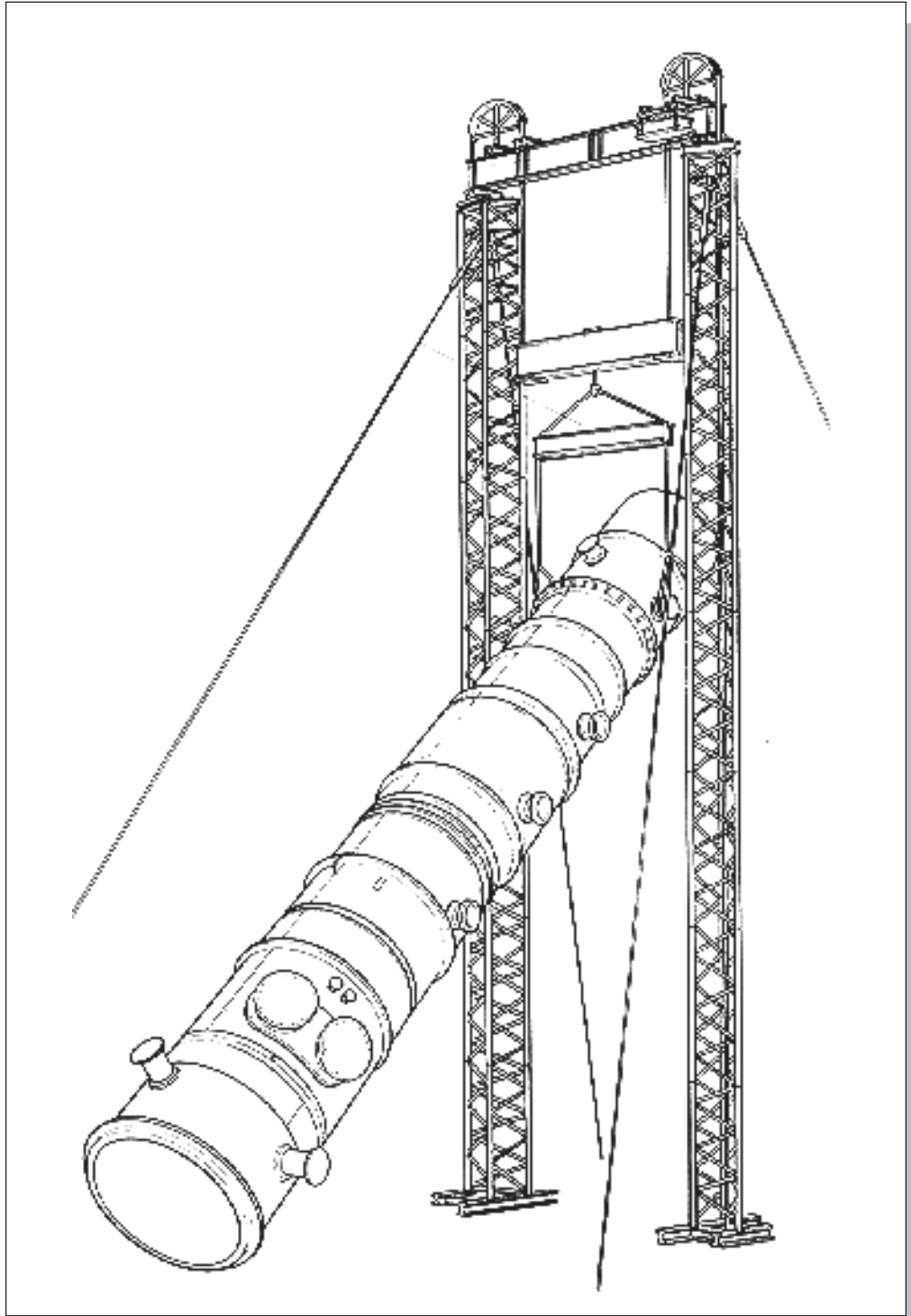

Figure 5.7-1 Gallows Pole Arrangement

The poles of a pole system consist of steel lattice towers and resemble a lattice crane boom. They are used in pairs. The “gin pole” configuration and the “gallows pole” configuration are two arrangements commonly used.

In the gin pole configuration, the poles are set up on the vessel foundation at either side of the vessel head’s lifting points. Hoist lines come down from offset sheaves attached to each of the pole tops and hook onto the vessel’s lift points. The lead lines run down the poles to a drum hoist (or hoists) on the ground. A tailing device or crane is required at the tail end of the vessel. The bases of the poles taper to a point and bear on the foundation on steel rocker bearings or ball joints. The tips of the poles are usually tapered to accommodate the set of hoisting sheaves and guy leads. A set of at least three guy lines supports each pole. The guys anchor into buried concrete deadmen. Buried deadmen use the weight of the surrounding soil to resist guy-tension; an alternative is to use massive aboveground dead weights. Guy lines are the most undesirable feature of pole systems. Many plant owners do not like guy wires hanging above their operating machinery and do not like to excavate holes for the deadmen. Furthermore, the guy tensioning procedure is time consuming and difficult.

The gallows pole configuration consists of a pair of poles topped by a header beam. The pole tips are equipped with bearing seats to support the header. A variety of hoisting mechanisms are available and usually hang from the header. The most common is similar to the system used for gin poles: A pair of head blocks attaches to the header and the lead lines run down the poles to drum hoists mounted on the ground. Another option is to incorporate a hydraulic jacking system onto the headers. The jacking system could be a strand lift system, a chain link jack system, a rod system, etc.

The gallows system has two advantages over the gin pole system. First, if a long enough header beam is used, the poles may be set up at some distance adjacent to the vessel’s foundation, thus avoiding obstructions on the ground or protruding platforms from the sides of the vessel. Second, the hoist head blocks (or jacking mechanism) can be mounted on a trolley on the header beam to accommodate side-shifting. Like gin poles, gallows’ frames usually require guying. If a four-pole system is used or required, internal guying can be used. The RMS System takes the pole concept one step farther. The RMS System resembles a gallows pole arrangement. The difference is that it is a jacking system and the header is jacked from the ground up.



Figure 5.7-2 Gallows Pole Arrangement

Consideration must be given to the space and method required to erect the pole system. If there is sufficient room on the ground, the entire pole system can be rocked up in one piece, including the header. If the system is too tall or there is insufficient room on the ground, assist cranes are required to set up the system.

5.8 STRAND JACKS

Another recent development in the lifting industry is the strand jack. This system consists of a hollow core hydraulic cylinder through which passes a series of steel strands. The strands are anchored to the jack via two sets of gripper chuck clusters; one fixed to the base or shell of the jack, and the other attached to the piston. The system raises the strand by alternately gripping with the piston chuck and extending the jack, then gripping and holding with the fixed lower chuck while retracting the jack. The cycle then starts again by gripping with the piston chuck and releasing the fixed lower chuck. The system is an adaptation of, and uses components from, concrete post-tensioning equipment (the steel strands and the gripper chucks). Hanging at the bottom of the strands is a third gripper chuck that is outfitted with a clevis eye (for a shackle or pin), which facilitates attachment to the load.

Strand jacks are quite versatile. They have been mounted within building structures, on trolleys for use as gantry cranes, and on crane boom tips for lifting. The bridge building industry initially used this system. The jacks were set up on bridge abutments to hoist prefabricated bridge segments into place from barges below. Capacities for an individual strand jack are usually in the 60 to 660 ton range. Groups of jacks are generally used for a lift, and combined lift capacities can exceed thousands of tons. Strand lift systems have the advantage of facilitating unlimited lift heights because any length of strands can be used. The excess strands exit from the top of the jack and drape back down, minimizing the head room. The strands may be reused several times but must be inspected for kinks and excessive gripper wear marks before each use.

To allow loads to be lowered using strand jacks, generally some type of strand guide is placed above the jack. This guide is generally a curved steel frame designed to support most of the weight of the strand wire portion that protrudes beyond the end of the strand jack. If a guide is not used, the wire can be kinked or hung up at the top of the jack and prevent jack lowering.

Enerpac makes a version of the strand lift system. Instead of a single center hole cylinder, Enerpac's system uses three smaller regular rams arranged in a triangular cluster. The strands attach to a structural cap plate and pass between the group of rams. The advantage of this arrangement over a single hollow core jack is serviceability during operation. If an individual jack becomes inoperative for any reason during the lift, the offending jack can easily be swapped out without needing to lower the load. It is impossible to service a hollow core jack after a lift commences because the strands are threaded through the center. If the hollow core jack does become inoperative, the load cannot be raised or lowered and outside assistance is required to free the load.



Figure 5.8-1 Strand Jack System

5.9 OTHER SYSTEMS

Closely related to the strand lift system are the rod jacking system and the chain system. Instead of multiple lifting strands, rod systems use a single rod, bar, or chain. Many of these systems are one-of-a-kind systems — no two are exactly alike. They consist of a hollow core jack or cluster of regular jacks through which the single lifting rod passes. When the jack is at full extension, the rod is dogged-off. The jack then retracts and takes another stroke. The jack-and-dog operation continues until the desired lift height is reached.

Some systems, such as the Heede system, use a square bar and gripper chucks to hold the rod. The Lucker system uses a single wire rope cable and also uses gripper chucks. The Bigge system uses threaded rods and has large split “nuts” to dog the rods. A Rigging International system uses a large flat bar; the bar has pin holes along its length with which to dog off. Several companies own chain jack systems. The chain links usually are made of 12- to 18-inch long forging and are connected with pins like a giant bicycle chain. The dog mechanism grips the chain at the pin. The chain system and cable system, like the strand systems, have the advantage of requiring little headroom because the cable or chain drapes or festoons after it passes the top of the jack. The rods on the rod systems come in segments and are anywhere from 5 to 20 feet long. The rods require an assist hoist to be removed.

In all of these systems, the jacking mechanism usually mounts on a trolley in some sort of gantry frame. However, the jacking mechanisms are usually removable and can be set up within building structures or on the top of poles or towers if necessary.

5.9.1 Hoisting Systems

Lifting Steam Drum of the Boiler Building, Practical Example

Steam drums for the conventional power plants normally are located at the top of the boiler structure and are suspended by U-bolts. Lifting the steam drum is performed by one of the following three methods:

- The most commonly used method is to anchor a hoist on the ground adjacent to the structure. Two hoist lines are run from the hoist to two multi-sheave head blocks at the top of the structure. This approach requires a series of snatch blocks and a “cathead” support for the head blocks.
- In recent years, strand jacking systems have become widely used for boiler steam drum lifts. This approach requires two sets of strand jacking systems placed at the top of the boiler. The jacks are mounted on a temporary support structure with side travel capabilities.
- Mobile cranes have been used occasionally to lift and set steam drums. This method is the most desirable if access, crane capacity, and reach are available.

Hoist systems are the most common apparatus used to lift steam drums. The installation

procedure will be described here with an example problem.

The steam drum is set after erection of the main steel members of the boiler structure. The drum is picked from the ground and hoisted within the structure to its final location at the top of the structure. Steam drums are longer in length than the steel building in which they are hoisted. Consequently, they are always hoisted in an inclined position. Equipment and hardware required to lift the steam drum consists of:

- A hoist with at least two drums. Each hoist drum must have sufficient line pull to hoist the steam drum.
- Two sets of catheads with links for connection of the upper blocks to the cathead main pin
- Two sets of multi-sheave head blocks and a series of snatch blocks
- Temporary structural steel for support of the cathead

To properly size the required equipment, hardware, and supports, the maximum loads must first be determined.

In order to properly size the required equipment, hardware and supports, the maximum loads

must first be determined.

Example:

A horizontal Steam Drum is 7.2' (86.4") diameter, 58' long and weighs 300 kips. Two lifting lugs are provided centered 6.75" above the vessels surface, and located 31' apart equidistant about the C of G. The Drum is to be located high in a steel structure and is to be hoisted into position; restricted access requires the Drum to be inclined at an angle of 42° to the horizontal during hoisting. Determine the lifting loads at each lug a) when horizontal, and b) during hoisting. Both lines of suspension are assumed to remain vertical throughout.

When horizontal, the C of G lies central between the lugs, therefore the load carried is equal in both = $300 / 2 = 150$ kips.

As the Drum is inclined, the geometry of the suspension is such that the line of action of the force (the Drums weight) acting through the center of gravity moves proportionally closer to the upper suspension transferring weight onto it and reducing the weight carried by the lower lug. See the sketches below.

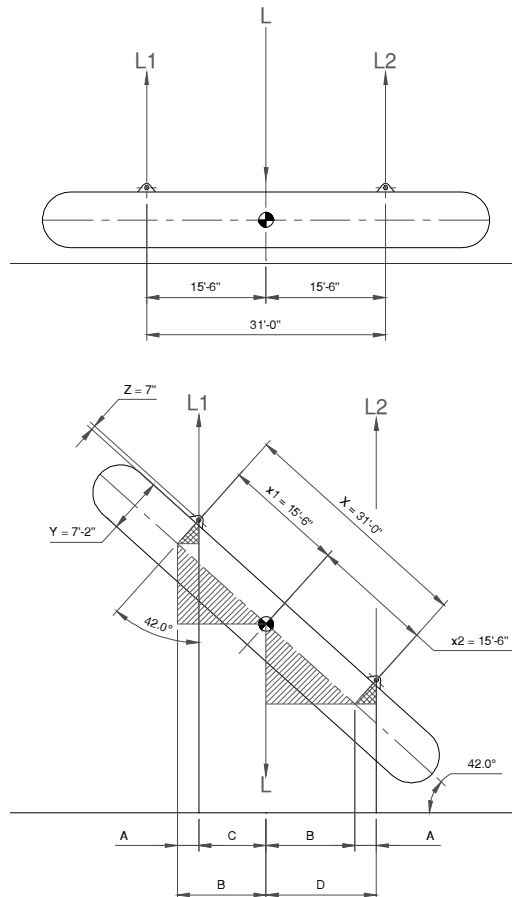

$$\begin{aligned}
 H &= Y/2 + Z \quad \textcircled{1} \quad 86.4'' + 6.75'' = 49.95'' \\
 A &= H \sin 42^\circ \quad \textcircled{2} \quad 49.95'' \sin 42^\circ = 33.42'' \\
 B &= x_1 \cos 42^\circ \quad \textcircled{3} \quad 186'' \cos 42^\circ = 138.22'' \\
 C &= B - A \quad \textcircled{4} \quad 138.22'' - 33.73'' = 104.8'' \\
 D &= B + A \quad \textcircled{5} \quad 138.22'' + 33.73'' = 171.95''
 \end{aligned}$$

$$\begin{aligned}
 L1 &= (D * L) / (C + D) \quad \textcircled{6} \quad (171.65'' * 300 \text{ Kips}) / (104.8 + 171.65) = 186.27 \text{ Kips} \\
 L2 &= (C * L) / (C + D) \quad \textcircled{7} \quad (104.8 * 300) / (104.8 + 171.65) = 113.73 \text{ Kips}
 \end{aligned}$$

Design both Lugs for 200 Kips

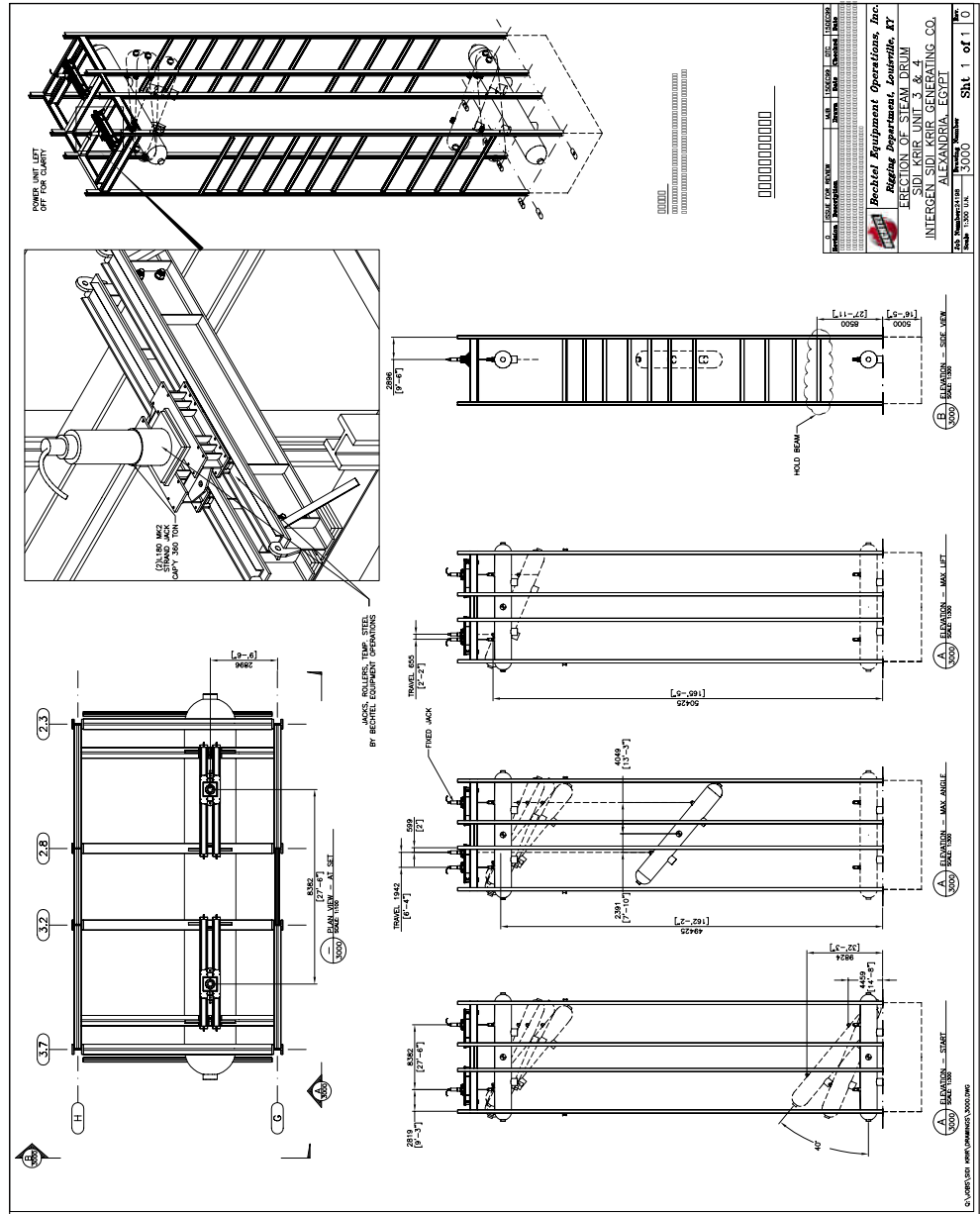

Figure 5.9-1 Typical Steam Drum Placement Using Strand Jacks

6

TRAILERS AND TRUCK TRACTORS



6. Trailers and Truck Tractors

6.1 GENERAL

Transporting plant equipment with conventional truck and trailer is a common operation on a construction site. In some cases, its responsibilities have been taken too lightly and problems have occurred.

Movement by transport is generally made on a hauling unit of standard manufacture. In selecting a hauling unit, the following items of information must be known:

- Stability triangle of the load on the trailer has been checked.
- The weight of the piece is within the design capability of the hauling unit.
- The configuration and structure of the bed of the hauling unit mat accommodate the piece or pieces.
- Axle loadings do not exceed floor or access road limitations.
- Maneuverability of the hauling unit must be compatible with the access route.
- Assistance that may be required to negotiate grades has been obtained.
- Adequate clearances have been verified along the access route.

In addition, the following should be considered when determining the feasibility of transporting a capacity load on a trailer.

6.2 TRAILERS

The type of load being applied to the trailer must be determined. This load could be classified in one of the following categories:

- Point load
- Uniform or equally distributed load
- Uncoupled load, where the tractor has been removed and the trailer is supported on the loading wheels
- Off center load

- Drive-on load from the rear or over the side
- Braking shear
- Torsional loading
- Vibrational loading

The design of a trailer main frame usually is of the center beam design, where the main support beams are closely spaced down the center of the trailer, or of the perimeter beams design, where the main support beam are located on the outside edge of the trailer bed.

Trailer manufacturers rate trailer capacity in different ways. Many manufacturers design and rate their trailers assuming that the load is spread evenly along the main deck. Some manufacturers rate their trailers based on a 17-foot long uniform load, while others use 8-foot uniform load. The distribution of the load imposed by the trailer is also an assumption made in design. This assumption also varies with the trailer manufacturer. However, in general, the design load distribution is based on 65 percent of the load to the rear wheels and 35 percent of the weight to the fifth-wheel pin.

6.3 TRUCK TRACTORS

The evaluation of the proper truck tractor for transporting heavy loads should include horsepower and tractive effort, front and rear axle rated capacity, fifth-wheel capacity, transmission reductions, and tire capacity.

6.3.1 Tractive Effort

Net tractive effort is defined as the torque or rim pull delivered to the tires at the ground. The following sections present the formulas for tractive effort.

6.3.2 Front and Rear Axle Capacities

A general purpose tractor will usually have a rear axle capacity at the ground of 44,000 pounds. To determine the allowable payload weight from the trailer, the complete tire weight of the tractor and trailer being supported on the tractor rear wheels at the ground must be subtracted from the capacity. For example, the tire weights of a conventional truck and trailer at the rear wheels is approximately 18,000 pounds. This tire weight subtracted from the capacity rating of the rear axle (44,000 pounds) leaves only 26,000 pounds of payload capacity. The attached sample tractor specification gives a rear axle capacity of 44,000 pounds for a general purpose tractor and 65,000 pounds capacity for the lowbed tractor. On a special heavy haul tractor, the rear axle capacity can be as high as 120,000 pounds. In addition, the front axle capacity should be checked, with special attention to the position of the fifth wheel and the weight transfer. See Figures 6.16-1 through 6.16-3 for typical tractor axle load distributions.

6.3.3 Tire Capacity

The weight being carried by each tire should be checked against the manufacturer's recommended loading. Sample manufacturer tire service loads and inflation tables are shown in Tables 6.17-1 through 6.17-3.

6.4 VEHICLE SPEED

Vehicle speed in miles per hour (m.p.h.) is the rolling radius of loaded driving tire multiplied by the engine r.p.m and divided by 168 times the overall gear reduction of the power train:

$$\text{m.p.h.} = \frac{rDm \times r}{168 \times R}$$

Where:

168 is a factor

r.p.m is the engine speed in revolutions per minute

R is the overall gear reduction, including both axle and transmission

m.p.h. is the vehicle speed in miles per hour

r is the rolling radius of loaded driving tire

Example:

Find the speed of a vehicle where the engine speed is 1,292 r.p.m, the rolling radius of loaded driving tire is 19.2 inches, and the overall gear reduction is 15.9.

$$\text{m.p.h.} = \frac{1292 \times 19.2}{168 \times 15.9} = 9.3 \text{ miles per hour}$$

6.5 TRACTIVE EFFORT

The tractive effort is obtained by multiplying the corrected engine torque by the total ratio of power train by the efficiency of the power train, and dividing this product by the rolling radius of the driving tires.

$$TE = \frac{T \times R \times e \times C \times 12}{r} \text{ (pounds)}$$

Where:

- T is the gross engine torque in lb.-ft.
- C is a correction factor for engine torque to determine net torque available at the flywheel; generally 0.85.
- R is the overall gear reduction including both axle and transmission.
- e is the mechanical efficiency of the drive line; generally 0.85.
- r is the rolling radius of loaded driving tire in inches.
- 12 is a constant converting lb-ft to lb-in.

Example:

Find the tractive effort where the rolling radius of driving tires is 19.5 inches, the total ratio of power train is 52.9, and the gross engine torque is 606 lb-ft.

$$\frac{606 \times 52.9 \times 0.85 \times 0.85 \times 12}{19.5} = 14,253 \text{ pounds}$$

6.6 NET TRACTIVE EFFORT

Net tractive effort is tractive effort with an allowance made for rolling resistance:

$$\text{Net TE} = \text{Tractive Effort} - \frac{(\text{RR})(\text{DAW})}{100}$$

Where:

RR is the rolling resistance (1.5% for concrete)

DAW is the driving axle weight (30,000 pounds)

Example:

$$\text{Net TE} = 14,253 - \frac{(1.5)(30,000)}{100} = 13,803 \text{ pounds}$$

Net tractive effort divided by the coefficient of friction (0.6 for average dry surface) equals the ideal weight on the rear axles. In the example then:

$$\text{Ideal weight} = \frac{13,803}{0.6} = 23,000 \text{ pounds}$$

If the weight is appreciably less than this amount, the tires will skid before starting to pull the load.

6.7 OVERALL REDUCTION

A truck has the following specifications:

Main transmission	8051C	first gear ratio 6.25 to 1.00
Auxiliary transmission	834IG	low gear ratio 1.60 to 1.00
Rear axle	SQHD	ratio 5.29 to 1.00

The overall reduction of any given truck is the product of the first gear ratio in the main transmission, the low (underdrive) ratio in the auxiliary transmission, and the rear axle ratio. The overall reduction is derived as follows:

$$(6.25) \times (1.60) \times (5.29) = 52.9 \text{ to } 1$$

6.8 GRADEABILITY

Obviously, the tractive effort available at the wheels must be greater than the sum of the rolling resistances encountered. If this is not so, the transmission must be shifted to a lower gear to increase the tractive effort. The percentage of grade that can be negotiated is given by the formula:

$$G = \frac{1200 \times T \times e \times C \times R}{r \times GVW} - RR$$

Where:

- 1,200 is a constant expressing the percentage of grade and feet
- T is the gross engine torque in Ib.-ft
- e is the mechanical efficiency of the drive line, generally 0.85
- C is a correction factor for gross engine torque to determine net torque available at flywheel, generally 0.85
- R is the rolling radius of the loaded driving tire in inches
- G.V.W. is the gross vehicle weight in pounds
- RR is the rolling resistance expressed as a percentage

Example:

What percentage grade can be negotiated by a vehicle having a gross engine torque of 265 ft-lb, an overall gear reduction in high gear of 4.12 to 1, a tire rolling radius of 19.2 inches, and a gross vehicle weight of 30,000 lb?

$$G = \frac{1200 \times 265 \times 0.85 \times 0.85 \times 4.12}{19.2 \times 30,000} - 1.4 = 0.24\%$$

Where: RR is 1.4%

6.9 GROUND SPEED OF TRACK LAYING VEHICLE

The ground speed of a track laying vehicle is the engine speed in revolutions per minute times the circumference of the driving sprocket divided by 168 times 2 times 3.1416 times the overall gear reduction of the power train:

$$V = \frac{\text{rpm} \times C}{168 \times 2 \times 3.1416 \times R}$$

Where:

V is the ground speed in m.p.h.

r.p.m is the engine speed in revolutions per minute

C is the circumference of the drive sprocket

Note: $C = N \times L$

N is the number of teeth on the sprocket

L is the length of links in inches

R is the overall gear reduction

Example:

Find the ground speed in miles per hour where the engine speed is 1,800 r.p.m, the number of teeth on the sprocket is 41, the length of the link is 8 inches, and the total reduction of power train is 61 to 1.

$$C = 41 \times 8 = 328 \text{ inches}$$

and:

$$V = \frac{1800 \times 328}{168 \times 2 \times 3.1416 \times 61} = 9.2 \text{ m.p.h.}$$

6.10 ROAD ROLLING RESISTANCE

The road rolling resistance is the force required to push a vehicle over the surface on which it is rolling and may be expressed in several ways. One way is in terms of pounds resistance per thousand pounds of gross weight. Other methods are derived from this basic expression. The following are typical rolling resistances:

- Concrete, excellent 10 lb.
- Concrete, good 15 lb.
- Concrete, poor 20 lb.
- Asphalt, good 12 lb.
- Asphalt, fair 17 lb.
- Asphalt, poor 22 lb.
- Macadam, good 15 lb.
- Macadam, fair 22 lb.
- Macadam, poor 37 lb.
- Cobbles, ordinary 55 lb.
- Cobbles, poor 85 lb.
- Snow, 2 inches 25 lb.
- Snow, 4 inches 37 lb.
- Dirt, smooth 25 lb.
- Dirt, sandy 37 lb.
- Mud 37 lb. to 150 lb.
- Sand, level soft sand 60 lb. to 150 lb.
- Sand, dune 160 lb. to 300 lb.

Rolling resistance is the gross vehicle weight in pounds times the rolling resistance of the surface divided by 1,000:

$$RR = \frac{GVW \times R}{1,000}$$

Where:

RR is the road rolling resistance in pounds

G.V.W. is the gross vehicle weight in pounds

R is the rolling resistance in pounds per thousand pounds of vehicle weight

1,000 is a constant to determine the number of thousand pounds in the vehicle

Example:

What is the rolling resistance of a vehicle having a gross weight of 7,000 pounds on poor asphalt?

$$RR = \frac{7000 \times 22}{1000} = 154 \text{ pounds}$$

Many formulas are arranged to use the resistances in the above table as a factor. To set the table data up in factor form, divide the resistance in pounds by 1,000:

$$Q = \frac{R}{1000}$$

Where:

Q is the rolling resistance factor per pound of gross vehicle weight

R is the rolling resistance in pounds per thousand pounds vehicle weight

Example:

What is the rolling resistance factor per pound of gross vehicle weight on good concrete?

$$Q = \frac{15}{1000} = 0.015$$

Another method of expressing road rolling resistance is in percent of grade. To express rolling resistance in percent of grade, multiply rolling resistance per thousand pounds vehicle by 100 and divide by 1,000.

$$\text{RR \% Grade} = \frac{R \times 100}{1000}$$

Where:

- RR % grade is the road rolling resistance in percent of grade
- R is the rolling resistance in pounds per thousand pounds vehicle weight
- 100 is a constant to express percent

Example:

What is the road rolling resistance expressed in percent of grade of a vehicle on good concrete?

$$\text{RR \% Grade} = \frac{15 \times 100}{1000} = 1.5\%$$

Typical Rolling Resistances for various types of road surfaces are listed in Table 6.10-1.

Table 6.10-1 Rolling Resistances for Various Road Surfaces

<u>Type of Road Surface</u>	<u>Rolling Resistance (Percent)</u>
Concrete and Asphalt	1.5
Hard Packed Dirt	2.5
Dry Dirt or Gravel	3
Soft Dirt	4
Wet Surface on Firm Base	4
Loose Sand or Gravel	10
Rutted and Soft Base	16

6.11 GRADES, SLOPES, AND GRADE RESISTANCE

Table 6.11-1 provides typical data for grade resistance for various grades and slopes.

Table 6.11-1 Grades, Slopes, and Grade Resistance

<u>Grade</u> ⁽¹⁾	<u>Slope</u> ⁽²⁾	<u>Grade resistance</u> ⁽³⁾
1	0°-34'	20
2	1°-9'	40
3	1°-43'	60
4	2°-17'	50
5	2°-52'	100
6	3°-26'	120
7	4°-0'	140
8	4°-34'	160
9	5°-9'	180
10	5°-43'	199
11	6°-17'	219
12	6°-51'	238
13	7°-24'	258
14	7°-58'	277
15	8°-32'	296
16	9°-5'	315
17	9°-39'	334
18	10°-12'	353
19	10°-45'	373
20	11°-19'	392
25	14°-2'	485
30	15°-17'	575
35	16°-42'	660
40	21°-48'	743
45	24°-14'	822
50	26°-34'	895
55	28°-49'	965
60	30°-58'	1,025
65	33°-1'	1,085
70	34°-59'	1,145
75	36°-52'	1,196
80	38°-40'	1,248
85	40°-22'	1,205
90	41°-59'	1,338
95	43°-32'	1,376
100	45°-0'	1,402

NOTES: ⁽¹⁾ Grade is expressed in percent per 100 horizontal feet

⁽²⁾ Slope is expressed in degrees and minutes per 100 horizontal feet

⁽³⁾ Grade resistance is expressed in pounds of pull per ton to overcome grade resistance

6.12 TYPICAL TIRE LOADED RADIUS

Table 6.12-1 lists typical tire loaded Radius

Size	Highway Tread	Off Highway Tread	Average Loaded Rolling Radius
9.00-20 (10x22.5)	19.0	19.2	19.50
10.00-20 (11x22.5) (18x19.5)	19.6	19.9	20.16
10.00-22 (11x24.5) (18x22.5)	20.7	20.8	21.15
11.00-20 (12x22.5) (19.5x19.5)	20.1	20.4	20.74
11.00-22 (12x24.5)	21.0	21.4	21.71
11.00-24	22.1	22.3	
12.00-20	20.8	21.2	
12.00-24	22.8	23.0	
14.00-24	24.3	25.3	

6.13 TYPICAL AXLE RATIOS

Typical axle ratios are listed in table 6.13-1.

Table 6.13-1 Typical Axle Ratios

Axle Model	Typical Ratios
R-140	3.70, 4.11, 4.33, 4.63, 5.29, 5.85, 6.14, 6.83, 7.40
R-170	3.70, 4.11, 4.33, 4.63, 4.88, 5.29, 5.85, 6.14, 6.83, 7.40
R-220	5.91, 6.38, 7.03, 7.79, 8.69, 9.71
R-230	4.11, 4.41, 4.77, 5.54, 5.91, 6.38, 6.51, 7.30, 7.79, 8.69, 9.71
U-200	5.91, 6.38, 7.03, 7.79, 8.69, 9.76
R-330 (Hi-Range)	4.41, 4.77, 5.54, 6.26, 7.09
R-330 (Lo-Range)	5.91, 6.38, 7.42, 8.38, 9.49
SLHD-SQHD	4.11, 4.44, 4.63, 4.88, 5.29, 5.83, 6.17, 6.83, 7.20, 7.80, 8.60
SSHD	4.11, 4.63, 5.29, 6.14, 6.83, 7.40
SLD-SLDD	4.68, 5.09, 5.56, 5.90, 6.41, 6.70, 7.00, 7.67, 8.43
SQD-SQDD	5.78, 6.44, 7.54, 8.31, 9.21
SRD-SRDD	5.78, 6.44, 7.54, 8.31, 9.21, 10.26
SUD-SUDD	7.24, 7.98, 9.00, 10.14, 11.08
SFD-SFDD 4640	8.08, 9.03, 10.16, 11.56
SQW	4.71, 5.67, 6.17, 6.80, 7.60, 8.20, 9.25
SPR-250	10.11

Note: Not all ratios listed are standard.

6.14 SAMPLE (UNIT)

6.14.1 Specifications — Lowbed Tractor

MODEL TYPE:	Conventional 6 x 4 heavy-duty construction type chassis.
DIMENSIONS:	Dimensions and weight distribution as shown in Figures 6.16-1 to 6.16-3.
ENGINE:	Detroit diesel model 8V71T, 75-mm injectors, 350 bhp (SAE) at 2,100 rpm, 990 lb.-ft. torque at 1,400 rpm, 568 cu. in. displacement, water cooled, 8 cylinder, V type, blower mounted turbo charger.
ENGINE EQUIPMENT:	Jacobs engine brake, oil cooler, flexible, aircraft type oil lines, full-flow oil filter, magnetic oil pan drain plug, dual fuel filters, cable operated engine shutdown, Bendix Westinghouse 12 cfm air compressor.
COOLING SYSTEM:	Surge tank dosed system type with radiator having 1,270 square inch frontal area, 4 7/16 inch thick core with 450 3/4-inch tubes in 5 rows, 11 fins per inch, 350 gallons per minute free flow, total cooling capacity of radiator core, top and bottom tanks 13.8 gallons, bolted top and bottom tanks, top tank baffled for deaeration. Full fan shroud.
ELECTRICAL SYSTEM:	85 mp Leece-Neville 2500 JB alternator. Two 12-volt Delco 1200 maintenance-free batteries rated at 475 cca each with 130 minimum reserve capacity; 24-volt starting system with automatic circuit breakers; 12-volt lighting system with automatic reset circuit breakers; oil and acid resistant plastic tape wrapped and tied harnesses with quick disconnect terminal blocks.
HOOD AND FENDERS:	Forward tilting, one piece, wide Unitglas hood and fenders; chrome outer radiator shell and chrome plated steel grill.
EXHAUST SYSTEM:	Single, vertical 5-inch exhaust with muffler and muffler guard. Exhaust to be cut level with cab top.
AIR CLEANER(S):	Dual 11-inch EBA dry type with filter restriction indicator, automatic moisture ejector, molded rubber sleeves, and stainless steel aircraft type clamps at all connections.

MAIN TRANSMISSION:	Fuller Model RT-1110, 10-speed twin countershaft, with a maximum torque capacity of 1,100 ft-lb 10 speeds forward and two speeds reverse; first gear ratio: 7.65 to 1, 10th gear ratio: 1 to 1. Single gear-shift lever with air operated range control.
AUXILIARY TRANSMISSION:	Fuller Model AT-1202A, 2-speed; 2.03 to 1 under-drive ratio and 1.00 to 1 direct drive ratio; Tulsa 830G5LU top mounted power tower winch drive.
CLUTCH:	Spicer angle spring 14-inch, 2-plate clutch with cushioned disk and dampened hub.
DRIVELINES:	1710 series with needlebearing universal joints; glide coated splines.
FRONT AXLE:	Timken Model FL931N, 18,000 lb. capacity at the ground, oil lubricated bearings, malleable steal hubs, 13 3/16-inch bolt circle with 1 inch wheel studs.
FRONT SUSPENSION:	Stacked spring, 24,000 lb. capacity with torque rods for front axle alignment.
STEERING SYSTEM:	Dual Seppard integral hydraulic power steering rated 20,000 lb. at the ground.
REAR AXLE(S):	Eaton Model 65DP planetary double reduction, load capacity 65,000 lb. at the ground, GCW rating 180,000 lb, 6.64 to 1 ratio, wide track, malleable hubs with 1-inch wheel studs on 13 3/16-inch bolt circle. Magnetic drain plug.
REAR AXLE SUSPENSION:	Kenworth Model KW6, 65,000 lb capacity.
SERVICE BRAKES:	Air operated S-Cam type 16 1/2 x 7 inches.
EMERGENCY/PARKING BRAKES:	MGM spring actuated air release type on both driving axles, high mounted for maximum ground clearance.
TIRES:	12:00 x 24 - 16 PR Goodyear hard rock lug, or equal (10 furnished).
WHEELS:	Steel disk wheels, 1-inch studs on 13 3/16 bolt circle (10 furnished).

- FRAME:** Straight one-piece from front bumper to rear frame; 110,000 psi steel; 10 3/4 x 3 1/2 x 3/8 inch with full length insert, 27.3 in.³ section modulus per rail, 3,102,000 lb. RBM per rail; crossmembers to be full depth steel, free fit bolted construction heat-treated flat washers under both bolt head and nut, nylon inserted lock nuts.
- BUMPER:** Aluminum with heavy duty V-brace and center tow hook.
- CAB:** Conventional style, composite fiberglass and aluminum construction with steel reinforcement for severe service conditions, mounted to frame with four rubber block vibration dampening shock mounts; bulkhead type aluminum doors fully sealed against air and dust hung from continuous, non-corrosive, piano-type hinges with bearing blocks top and bottom for additional support.
- SEATS:** Driver: Bostrom West Coaster.
Companion: Fixed, molded fiberglass with full back.
- CAB FEATURES:** Windshield(s) and door windows tinted, heat absorbing laminated safety glass; 17 x 28 inch fixed rear cab window; safety window right door; left and right inside door locks; cowl vent with bug screen; fiberglass insulation in roof cab, doors, and rear panel; tilt-out instrument panel for full access to all instruments and circuit breakers; all instruments and switches individually back lighted.
- ACCESSORIES:** Dual air-operated variable speed windshield wipers with separate motors and heavy-duty non-glare arms and parking control; windshield washers; cab dome light over each door; dual air horns; dual electric horns; cab mounted dual 6 x 16 inch rearview mirrors; single inside sun visor left side.
- INSTRUMENTS & WARNING DEVICES:** Tachometer; speedometer with odometer in kilometers; ammeter; oil pressure, water temperature, air reservoir and application pressure gauges; high beam indicator; high water temperature, low oil, and air reservoir pressure warning lights; electric fuel gauge.
- FUEL TANK(S):** Dual 55 gallon 22-inch diameter steel high mount.

LIGHTS:	Dual headlights; 5 ICC marker lights; directional signals with all flasher controlled lights fender mounted; dual stop and tail lights; back-up light.
SEVERE SERVICE ITEMS:	<p>The following is a minimum list of additional items included for severe service.</p> <ol style="list-style-type: none">1. Steel battery holddowns.2. Heavy-duty forged aluminum 3-hole gussets on auxiliary transmission crossmember.3. Steel fuel tank brackets and heavy-duty anchors for fuel tank straps.4. Main transmission support springs.5. Heavy-duty exhaust mounting brackets.6. Steel tubular underbellhousing crossmember.7. Steel front engine supports.8. Steel flywheel housing.
TRACTOR EQUIPMENT:	Holland W-70-0 single oscillating heavy-duty fifth wheel with 31/2 inch king pin jaws; tractor kit complete with breakaway, hand control valve, 12-foot trailer air and light lines and hoesenna.
SPECIAL EQUIPMENT:	Integral cab guard and winch platform constructed of A53 schedule 40 seamless pipe and 6 x 6 x 1/2 inch angle base mounted on channel and bolted to truck frame; Braden model 50 winch rated at 100,000 lb line pull on first layer, 200 foot 1 inch cable, 2 feet of 1 inch tail chain with hook, air operated controls in cab and manual controls right side of winch installation; possom belly tool tray extending from winch mounting base to fifth wheel mounting angles; fifth wheel ramp from end of truck frame to fifth wheel mounting angles; full frame with 8 inch diameter tail roller.
PAINT:	Cab, chassis, and special equipment painted Wimbledon White.

6.15 SAMPLE (PROJECT)

6.15.1 Specific Unit Requirements - Tractor, General Purpose

DIMENSIONS:	Wheelbase, 230 inches; back of cab to end of frame, 222 inches.
ENGINE:	300 Horsepower minimum.
MAIN TRANSMISSION:	Fuller RT12515, 15-speed, twin countershaft, direct in 15th.
AUXILIARY TRANSMISSION:	None.
FRONT AXLE TYPE:	Non-driving.
REAR AXLE:	Operating conditions to be on highway; capacity at ground, 44,000 lb; G.C.W. capacity, 100,000 lb.
TIRES:	Front, 11:00 x 22, 16-ply hard rock rib; Rear, 11:00 x 22, 16-ply hard rock rib.
WHEELS:	8 x 22 inch steel; 10 hole, 11 1/4 inch bolt circle, 1 inch stud.
FRAME:	Class B.
FUEL TANK(S):	Two.
TRACTOR EQUIPMENT:	Holland FW-70-D single oscillating fifth wheel with 2 inch kingpin. 12 foot trailer air and light lines suspended from the headache rack by springs. Cab guard to be rectangular shape, 90 inches wide x 74 inches above frame rail. Perimeter to be 4 x 2 inch rectangular tubing with minimum of 3 horizontal cross bars. Bottom perimeter member to be 6 inches above truck frame. Headache rack mounted to angle, overlaid on frame and bolted through frame web, with bolt-in open storage box between angles with 6 inch sides and expanded metal bottom.

6.15.2 Specific Unit Requirements - Tractor, Lowbed/Winch

DIMENSIONS:	Wheelbase, 230"; Back of Cab to End of Frame, 222".
ENGINE:	400 Horsepower minimum.
MAIN TRANSMISSION:	Fuller RT-12515, 10-speed, twin countershaft, direct in 15th.
AUXILIARY TRANSMISSION:	Fuller AT1202, 2-speed, with top mounted P.T.O. for winch drive.
FRONT AXLE:	Non-driving.
REAR AXLE:	Operating conditions to be on/off highway; capacity at ground, 44,000 lbs.; G.C.W. 170,000 lbs.
TIRES:	Front, 11:00 x 22, 16 ply hard rock rib; Rear, 11:00 x 22, 16 ply hard rock rib.
WHEELS:	8.0" x 22" steel; 10 bole, 11 1/4" bolt circle for 1" studs.
FRAME:	Class C.
FUEL TANK(S):	Two.
TRACTOR EQUIPMENT:	Holland FW-70-0 single oscillating fifth wheel with 3 1/2" kingpin jaws. 12 foot trailer air and light lines suspended from the headache rack by springs.
SPECIAL EQUIPMENT:	<p>Integral headache rack and winch platform constructed of A53 schedule 40 seamless pipe and 6" x 6" x 1/2" angle base mounted on channel and bolted to truck frame. Rear angle of winch to be secured by U-bolts around truck frame. Roller guides to be A53 schedule 40 seamless pipe.</p> <p>Winch to be rated 60,000 lbs. first layer on 8" diameter drum barrel, 3 1/4" diameter drum shaft. Oil cooled, fully adjustable automatic safety brake. 200 ft. 1" 6 x 31 IWRC cable, 2 ft. of 1" tail chain and hook. Air operated controls in cab and manual controls right side of winch installation.</p> <p>Tool tray constructed of A36 structural steel and expanded metal bottom extending from winch mounting base to 5th wheel mounting angles.</p> <p>Fifth wheel ramp from end of truck frame to fifth wheel mounting angles.</p> <p>Full frame width 8" diameter rail roller with removable spherical bushings; lube fittings for bushings. Entire tail roller assembly to be bolted to truck frame.</p>

6.16 SAMPLE TRACTOR AXLE LOADINGS

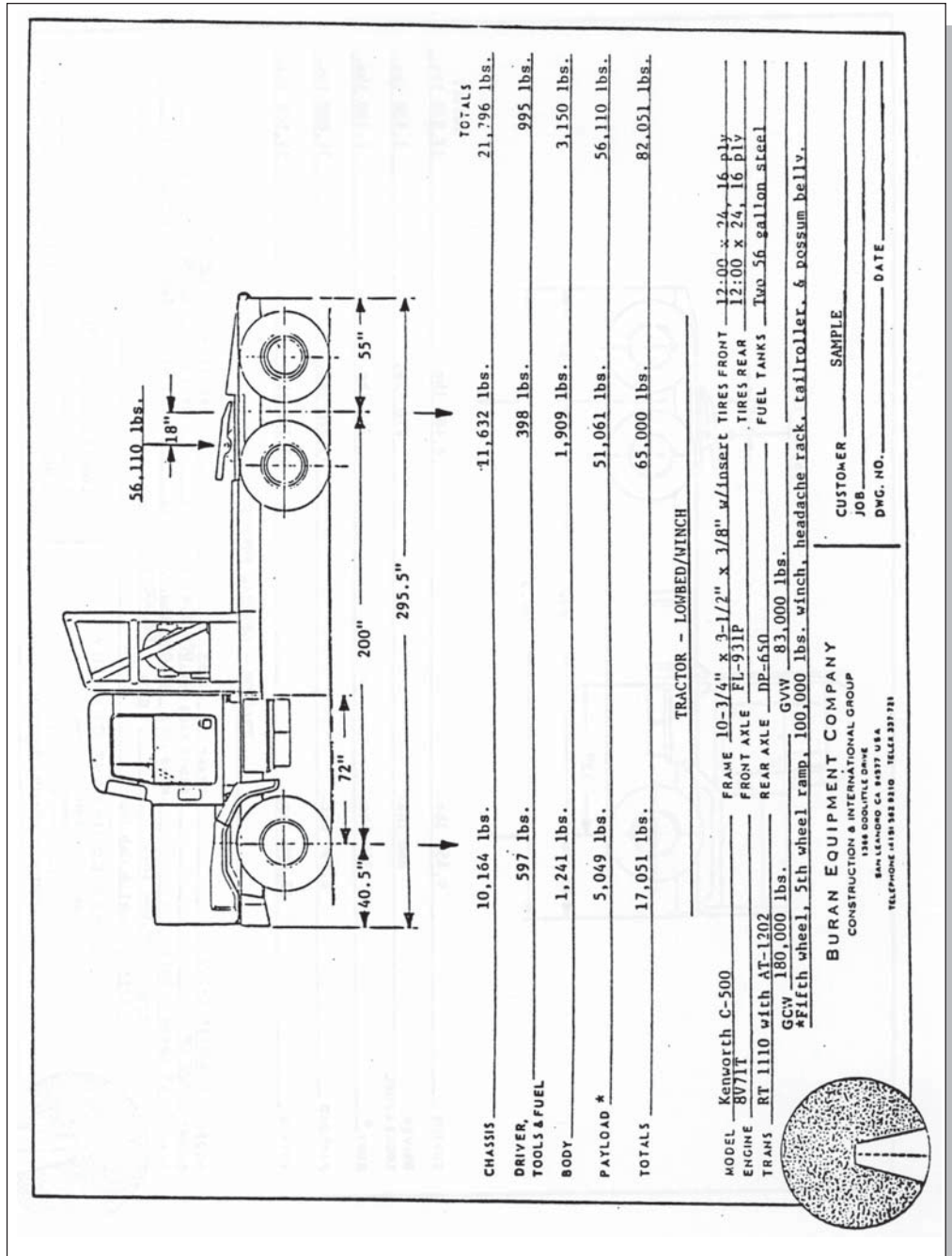

Figure 6.16-1 Tractor — Lowbed/Winch Sample

6.17 SAMPLE TIRE SERVICE LOAD AND INFLATION TABLES

Table 6.17-1 Service Load and Inflation Table

TIRES FOR TRUCKS, BUSES AND TRAILERS USED IN NORMAL
HIGHWAY SERVICE(BIAS AND RADIAL PLY) TIRES USED AS DUALS
(TIRES MOUNTED ON TYPE I, II, AND III RIMS)

TIRE LOAD LIMITS AT VARIOUS COLD INFLATION PRESSURES

Size	40	45	50	55	60	65	70	75	80	85	90	95	100
6.50-20	1630	1750	1860(C)	1970	2070	2170(D)							
7.00-15	1510	1610	1720	1820	1910	2000	2090	2180	2260	2340	2420	2500(F)	
7.00-17	1640	1760	1870(C)	1980	2080	2180(D)							
7.00-18	1710	1830	1950	2060	2170	2270(D)							
7.00-20	1840	1980	2100	2220	2340	2450(D)	2560	2660	2750(E)				
7.50-15	1700	1820	1940	2050	2160	2260	2360	2460	2550(E)	2640	2730	2820(F)	
7.50-17	1850	1990	2110	2230	2350	2460(D)	2570	2680	2780(E)				
7.50-18	1920	2060	2190	2310	2430	2550(D)	2670	2780	2890	2990	3090	3190	3200(G)
7.50-20	2070	2220	2350	2490	2620	2750(D)	2870	2990	3100(E)	3210	3320	3430(F)	
8.25-15	2030	2170	2310	2440	2570	2700	2810	2930	3040	3150	3260(F)	3360	3470(G)
8.25-17	2220	2360	2510	2650	2790	2930	3060	3180(E)					
8.25-18	2280	2450	2600	2750	2900	3040	3170	3300(E)					
8.25-20	2460	2640	2800	2960	3120	3270	3410	3550(E)	3690	3820	3950(F)		
9.00-15	2590	2760	2920(D)	3070	3210	3360	3490	3630	3760(F)	3890	4010	4130(G)	
9.00-18	2910	3100	3270	3440	3610	3770(E)							
9.00-20	3120	3310	3510	3690	3870	4040(E)	4200	4360	4520(F)				
10.00-15		3140	3320	3490	3660	3830	3980(F)	4130	4280	4430(G)	4570	4710(L)	
10.00-20		3760	3970	4180	4380	4580	4760(F)	4950	5120	5300(G)			
10.00-22		4000	4230	4450	4660	4870	5070(F)	5260	5450	5640(G)			
11.00-15		3430	3630	3820	4000	4180	4350	4520	4680	4840	5000	5150(H, L)	
11.00-18		3830	4060	4270	4470	4670	4860(F)						
11.00-20		4100	4330	4560	4780	4990	5190(F)	5390	5590	5780(G)			
11.00-22		4350	4600	4840	5080	5300	5520(F)	5730	5940	6140(G)			
11.00-24		4620	4890	5140	5390	5630	5860(F)	6090	6310	6520(G)			
11.50-20		4180	4420	4650	4870	5090	5290(F)	5500	5700	5890(G)			
11.50-22		4440	4700	4940	5180	5410	5630(F)	5850	6060	6270(G)			
12.00-20			4930	5190	5440	5680	5910	6140(G)	6360	6580	6790(H)		
12.00-24			5550	5840	6120	6390	6650	6910(G)	7160	7410	7640(H)	7870(L)	

- NOTES: 1: Letters in parenthesis denote *load range* for which underscored Loads are maximum.
- 2: For restricted speed highway service not exceeding 50 MPH, the above loading ratings may be increased 9%. Important — consult rim and wheel manufacturers for availability and engineer specifications of rims and wheels for these applications.

Table 6.17-2 Service Load and Inflation Table

TIRES USED AS SINGLES

(TIRES MOUNTED ON TYPE I, II, AND III RIMS)

TIRE LOAD LIMITS AT VARIOUS COLD INFLATION PRESSURES													
Size	40	45	50	55	60	65	70	75	80	85	90	95	100
6.50-20			1860	2000	2120(C)	2250	2360	2470(D)					
7.00-15			1720	1840	1960	2070	2180	2280	2380	2490	2580	2670	2780(F)
7.00-17			1870	2010	2130(C)	2260	2370	2480(D)					
7.00-18			1950	2090	2220	2350	2470	2580(D)					
7.00-20			2100	2260	2390	2530	2670	2790(D)	2920	3030	3150(E)		
7.50-15			1940	2070	2210	2340	2460	2580	2690	2800	2910(E)	3010	3110(F)
7.50-17			2110	2270	2410	2540	2680	2800(D)	2930	3060	3170(E)		
7.50-18			2190	2350	2500	2630	2770	2910(D)	3040	3170	3290	3410	3520(G)
7.50-20			2360	2530	2680	2840	2990	3140(D)	3270	3410	3530(E)	3660	3780(F)
8.25-15			2310	2470	2630	2780	2930	3080	3200	3340	3470	3590	3720(F, *G)
8.25-17			2510	2690	2860	3020	3180	3340	3490	3630(E)			
8.25-18			2600	2790	2960	3140	3310	3470	3610	3760(E)			
8.25-20			2800	3010	3190	3370	3560	3730	3890	4050(E)	4210	4350	4500(F)
9.00-15			2950	3150	3330(D)	3500	3660	3830	3980	4140	4290(F)	4430(G)	
9.00-18			3320	3530	3730	3920	4120	4300(E)					
9.00-20			3560	3770	4000	4210	4410	4610(E)	4790	4970	5150(F)		
10.00-15			3580	3780	3980	4170	4370	4540(F)	4710	4880	5050(G, *L)		
10.00-20			4290	4530	4770	4990	5220	5430(F)	5640	5840	6040(G)		
10.00-22			4560	4820	5070	5310	5550	5780(F)	6000	6210	6430(G)		
11.00-15			3910	4140	4350	4560	4770	4960	5150	5340	5520(H, *L)		
11.00-18			4370	4630	4870	5100	5320	5540(F)					
11.00-20			4670	4940	5200	5450	5690	5920(F)	6140	6370	6590(G)		
11.00-22			4960	5240	5520	5790	6040	6290(F)	6630	6770	7000(G)		
11.00-24			5270	5570	5860	6140	6420	6680(F)	6940	7190	7430(G)		
11.50-20			4770	5040	5300	5550	5800	6030(F)	6270	6500	6710(G)		
11.50-22			5060	5360	5630	5910	6170	6420(F)	6670	6910	7150(G)		
12.00-20			5620	5920	6200	6480	6740	7000(G)	7250	7500(H)			
12.00-24			6330	6660	6980	7280	7580	7880(G)	8160	8450(H, *L)			

- NOTES: 1: Letters in parenthesis denote load range for which underscored loads are maximum.
- 2: For restricted speed highway service not exceeding 50 MPH, the above loading ratings may be increased 9%. Important — consult rim and wheel manufacturers for availability and engineer specifications of rims and wheels for these applications.

Table 6.17-3 Service Load and Inflation Table

TIRES FOR FORK LIFT TRUCKS, MOBILE CRANES, SHOVELS, MINING CARS, FRONT END LOADERS AND DOZERS

MAXIMUM SPEED — 5 MILES PER HOUR

TABLE LP-1F

TIRE LOAD LIMITS AT VARIOUS COLD INFLATION PRESSURES														
Tire Size	35	40	45	50	55	60	65	70	75	80	85	90	95	100
7.00-15	2410	2600	2790	2970	3140	3300	3460	3610	3760	3910	4050	4190	4320	4450(12)
7.00-20	2940	3170	3410	3630	3840	4030	4230	4420	4600	4770	4950	5120	5280(10)	5440(12)
7.50-10	1960	2120	2270	2410	2550	2690	2810	2940	3060	3180	3290	3400	3510(10)	3420(12)
7.50-15	2710	2940	3150	3350	3540	3720	3900	4080	4240	4410	4560	4720(10)	4870	5020(12)
7.50-18	3060	3310	3540	3770	3990	4190	4400	4590(8)	4780	4960	5140	5320(10)	5490	5660(12)
7.50-20	3300	3570	3830	4070	4310	4530	4750	4960(8)	5160	5360	5550	5740(10)	5920	6110(12)
8.25-15	3240	3500	3750	3990	4220	4440	4660	4860	5060	5260	5450	5630	5810	5990(12)
8.25-18	3650	3940	4220	4490	4750	5000	5240	5470	5700	5920(10)				
8.25-20	3990	4240	4550	4840	5120	5380	5640	5890	6130	6370(10)	5500	6830	7040	7280(12)
9.00-10	2630	2850	3050	3240	3430	3610	3780	3950	4110	4270(10)	4420	4580	4720	4860(12)
9.00-15	3860	4170	4470	4750	5030	5290	5550	5790	6030	6260	6490	6710(12)		
9.00-20	4640	5020	5380	5720	6050	6370	6680	6970	7260	7530	7810	8070(12)		
10.00-15	4400	4750	5100	5420	5730	6030	6320	6600	6870	7140	7390	7650	7890(14)	
10.00-20	5260	5690	6090	6480	6860	7210	7560	7890	8220	8530	8840(12)	9140	9430(14)	
11.00-20	5740	6200	6650	7070	7480	7870	8250	8610	8970	9310(12)	9650	9980(14)		
12.00-20	6540	7070	7570	8060	8520	8960	9400	9810	10210	10610	10990(14)	11370	11730	12080(16)
*12.00-24	7240(6)	7830	8390	8920(8)										
*13.00-24	8510(6)	9200	9880(8)	10490	11100	11670	12240	12780(12)	13300	13810	14310	14800(16)		
14.00-20	8980	9710	10400	11070	11710	12310	12910	13480	14030	14570	15100	15610	16110(18)	16800(20)
*14.00-24	10020	10830(8)	11610	12350	13060	13740	14400(12)							
14.00-24	10020	10830	11610	12350	13060	13740	14400	15040	15650	16250	16840	17420	17970	18520(20)
*16.00-24	13670	14780	15840	16850(12)										

TABLE LP-2

16.00-25	13120	14180	15200	16170	17100	17990	18860	19690	20500	21280	22050	22810	23530(24)	
18.00-25	16940	18320(12)	19630	20880	22090(16)	23230	24360	25440(20)	26470	27490(24)				
21.00-25	21810	23580	25270	26880(16)	28430	29900(20)	31350	32740(24)	34070	35380	36660(28)			
24.00-25	28170	30450	32640(18)	34720	36720	38620	40490(24)	42280	44010	45700(30)				
24.00-29	30170	32620	34980(18)	37180	39330	41370	43370(24)	45290	47140	48950(20)				
36.00-41	76650	82880	88820	94470	99930	105110	110190	115070	119770	124370	128870(48)			
36.00-51	84920	91820	98400	104670	110720	116450	122080	127490	132890(42)	137790	142780(50)	147660	152330	157000(50)

*These tires used on S.D.C. rims.

- NOTES: 1: For 10 MPH service, the above loads must be reduced 13% at the same inflation pressures.
- 2: For stationary service conditions, the above loads may be increased up to 57% with no increase in inflation.



7. Transportation

7.1 HEAVY HAULING AND TRANSPORTATION

This section discusses the transportation of heavy equipment, generally weighing 50 tons or more. To transport heavy plant equipment on the construction site or on public roads requires specialized land transporters. Various types of transporters include:

- Multi-axle hydraulic platform trailers
- Self-propelled multi-axle hydraulic platform trailers
- Low-bed/multi-axle transporters
- Crawler transporters
- Schnabel cars

7.1.1 Multi-Axle Hydraulic Platform Trailers

Multi-axle hydraulic platform trailers form the backbone of the world's fleet of heavy haul transporters. Manufacturers of this equipment include Scheurle, Goldhofer, Trabosa, Nicholas, and Cometto. Platform trailers must be towed and/or pushed by a separate tractor or series of tractors that are typically referred to as the prime mover(s).

A hydraulic platform trailer consists of a structural steel deck supported by an array of axle bogies. The axle bogie suspension is the heart of the hydraulic platform trailer. Each bogie is connected to the trailer deck and is supported by a linkage that consists essentially of a hydraulic cylinder or ram. All of these bogie cylinders are interconnected hydraulically. This hydraulic interconnection enables the deck of the trailer to be raised or lowered by pumping or draining fluid from the rams. Second, considering Pascal's law and applying his hydraulic principle to the interconnected hydraulic system, the transporter bogies will each support an equal load, regardless of where or how the load is applied to the deck of the transporter. This equalization means that the ground or bearing surface on which the transporter is traveling will see a uniform loading. The linkage and suspension are further refined to permit each bogie to tilt or pivot laterally, thus ensuring equal distribution to each tire. Each bogie swivels independently, allowing the transporter to be steered. An array of steering links enables the transporter to perform coordinated turns. Because of the large quantity of bogies, steering is hydraulically assisted. Steering input comes from the tow vehicle (prime mover) via a steel drawbar. Turning the drawbar actuates hydraulic cylinders that control the steering links, which, in turn, steer the bogies.

A feature typical to most hydraulic platform trailers is modularization. Depending on the manufacturer, the trailers come in modules of 2, 3, 4, 5, etc., axle lines (or files). Modules can be linked together longitudinally to create a trailer of virtually any length. In addition, the trailer modules can be linked together laterally to make double wide or even one and one-half wide platforms.

The actual hydraulic arrangement of the bogie cylinders must be statically determinate, which means that there must be three isolated hydraulic loops that correspond to a triangular support arrangement. This arrangement is referred to as the stability triangle or “three-point suspension.” Usually, two lateral loops are located at the front of the trailer, and a single loop is located at the rear of the trailer. A four-loop system is possible but will not provide calculable or predictable loadings to the deck or supporting surface. The bogies within a particular loop are linked hydraulically; thus, Pascal’s law applies and the bogies within that loop each see the identical load, regardless of bumps or potholes in the road. However, each of the three loops may not see the same load because of tilt, pitch, and the location of the payload’s center of gravity. This must be determined with statics calculations. The three hydraulic loops allow the deck to be leveled. If the deck is tilting to one side, one of the lateral loops can be pumped up to extend the rams on that side and eliminate the tilt. If the deck is pitching toward the rear, the rear loop can be extended (or the two lateral loops in the front can be retracted).

The entire platform can be raised by extending the rams in each loop simultaneously. This feature, in many cases, eliminates the need for a lift crane for loading and offloading if temporary stands and outrigger beams are used under the payload.

Hydraulic power is supplied to the bogie rams and the steering rams from a power pack that consists of a pump, motor, reservoir, valving, and instrumentation. The power pack is manually operated, independent of the prime mover, and is typically mounted at the rear of the transporter.

Information needed to develop a heavy haul transportation plan using hydraulic platform trailers includes the following:

- Weight and center of gravity of the equipment to be hauled
- Permissible equipment support location
- Maximum permitted axle load on supporting surface (road, bridge, etc.)
- Haul route grades
- Haul route turning radii
- Overhead and lateral clearances along the haul route

With this information, the haul planner can choose the proper transporter, transporter configuration, and prime movers.



Figure 7.1-1 16-Line Hydraulic Platform Trailer Hauling a HRS Module

Constructions for Module Technic	Type K/100/4		
	Speed	50 kmh	20 km/h: 5 kmh
	Gross weight	80000	96000 112000 kg
	Weight unladen, approx.	19500	19500 19500 kg
	Payload capacity approx.	60500	76500 92500 kg
	Axle pressure	4 x 20000	24000 28000 kg
	Loading length		6350 mm
	Loading width		3000 mm
	Loading height		1250 ± 250 mm
	Tires		32 fold 7.50-15

Figure 7.1-2 Single Wide, 4 Line Platform Trailer, Typical Data

	Type K 150/6 and K 100/4 2 x 6 lines of axles and 2 x 4 lines of axles, longitudinally and transversally coupled		
	Speed	20 kmh	8 kmh
Gross weight	480000	500000	560000 kg
Weight unladen, approx.	80000	80000	80000 kg
Payload capacity	400000	420000	480000 kg
Axle pressure	20 x 24000	25000	28000 kg
Loading length			14950 mm
Loading width			6250 mm
Loading height			1075 mm ± 250 mm
Loading height, alternative			1250 mm ± 300 mm
Tires			160 fold 7.50-15

Figure 7.1-3 Double Wide, 10 Line Platform Trailer, Typical Data

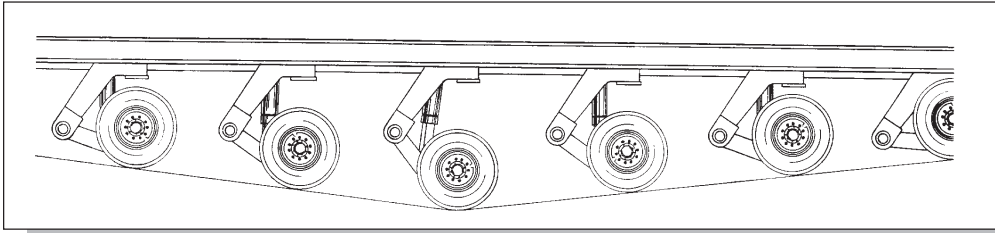
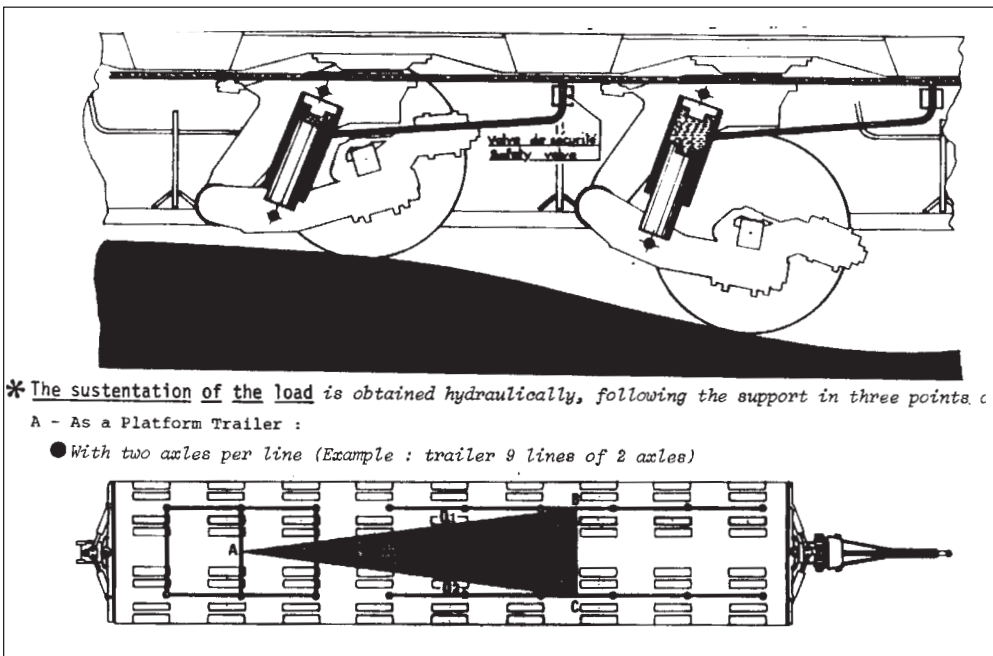

Figure 7.1-4 Platform trailer Hydraulic Suspension



* The sustentation of the load is obtained hydraulically, following the support in three points. c

A - As a Platform Trailer :

- With two axles per line (Example : trailer 9 lines of 2 axles)

Figure 7.1-5 Platform Trailer Hydraulic Suspension and Stability Triangle

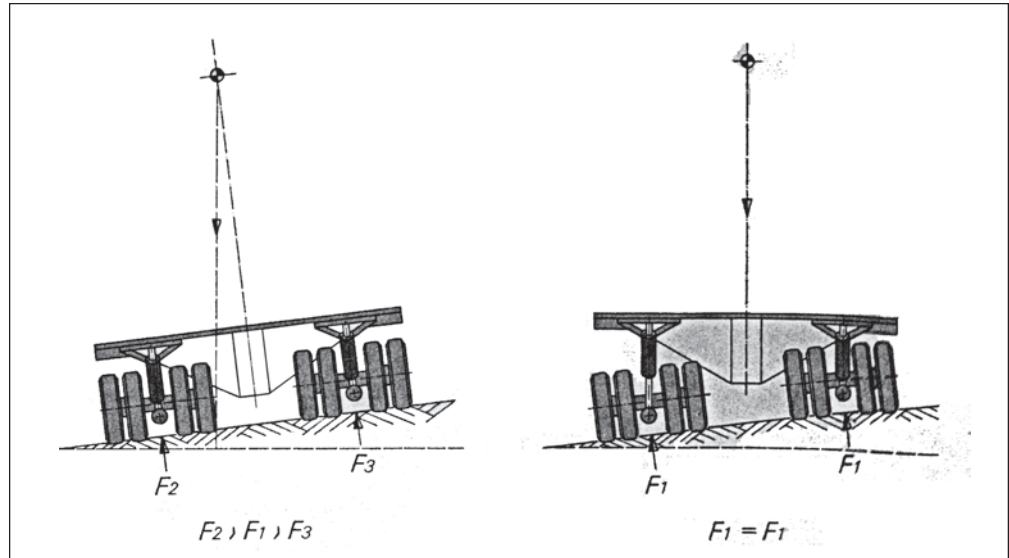

Figure 7.1-6 Self Leveling Capability

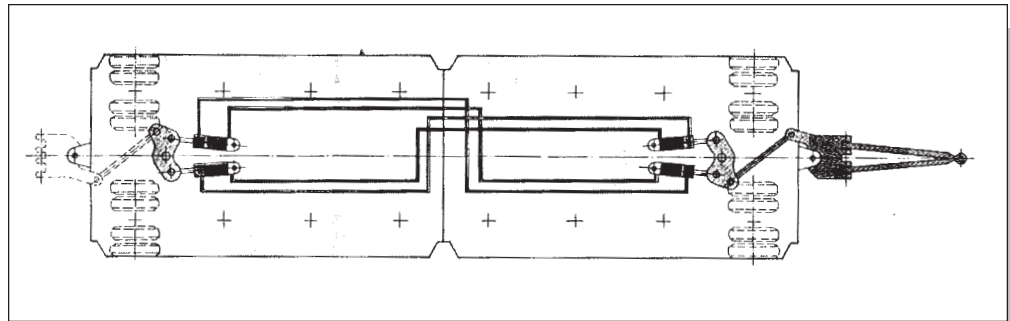

Figure 7.1-7 Hydraulic Steering Schematic

7.1.2 Self-Propelled, Multi-Axle Hydraulic Transporters

Multi-axle hydraulic platform trailers have traditionally required prime movers as tow vehicles. With recent advancements in technology, manufacturers have developed completely self-propelled transporters, eliminating the need for a tow vehicle. To increase maneuverability, these self-propelled transporters feature independent, 360-degree steering for all bogies. High maneuverability combined with a slightly greater capacity per axle line than a similar platform trailer make self-propelled transporters desirable for many transportation jobs. The only disadvantage when compared with towed platform trailers is the slower top speed. The theoretical top speed is limited by the capacity of the high torque hydraulic drive motors; whereas the top speed of towed trailers is limited by the prime mover speed. Practical factors such as stability, structural capacity of the deck, and dynamic effects play a major part in determining the overall haul speed.

Self-propelled transporters are modular and can be linked together longitudinally to create a transporter of any length. However, they do not necessarily need to be linked together. Transporter modules can be separated and placed at multiple payload support points. The individual transporter modules can then be linked electronically for uniform control of steering and movement.

The various figures in this section illustrate the versatility of self-propelled transporters for maneuverability and configuration flexibility. Up to one-half of the wheels in a transporter module can be powered drive wheels. These wheels provide superior tractive effort. With 360-degree steering and high traction, payloads can be positioned extremely accurately even in rugged or confined jobsites.

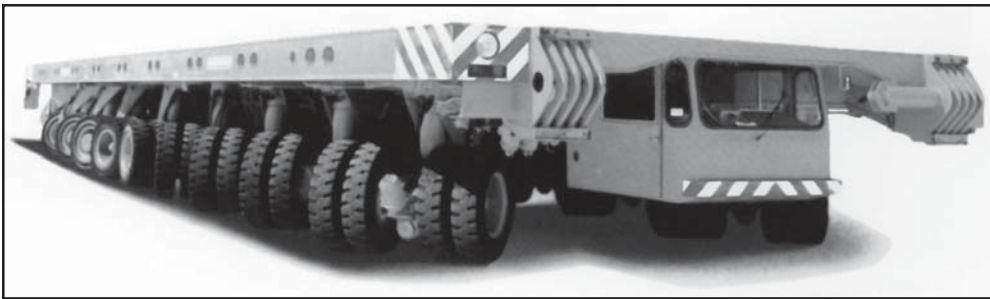

Figure 7.1-8 Scheuerle Self-Propelled Multi-Axle Hydraulic Transporter

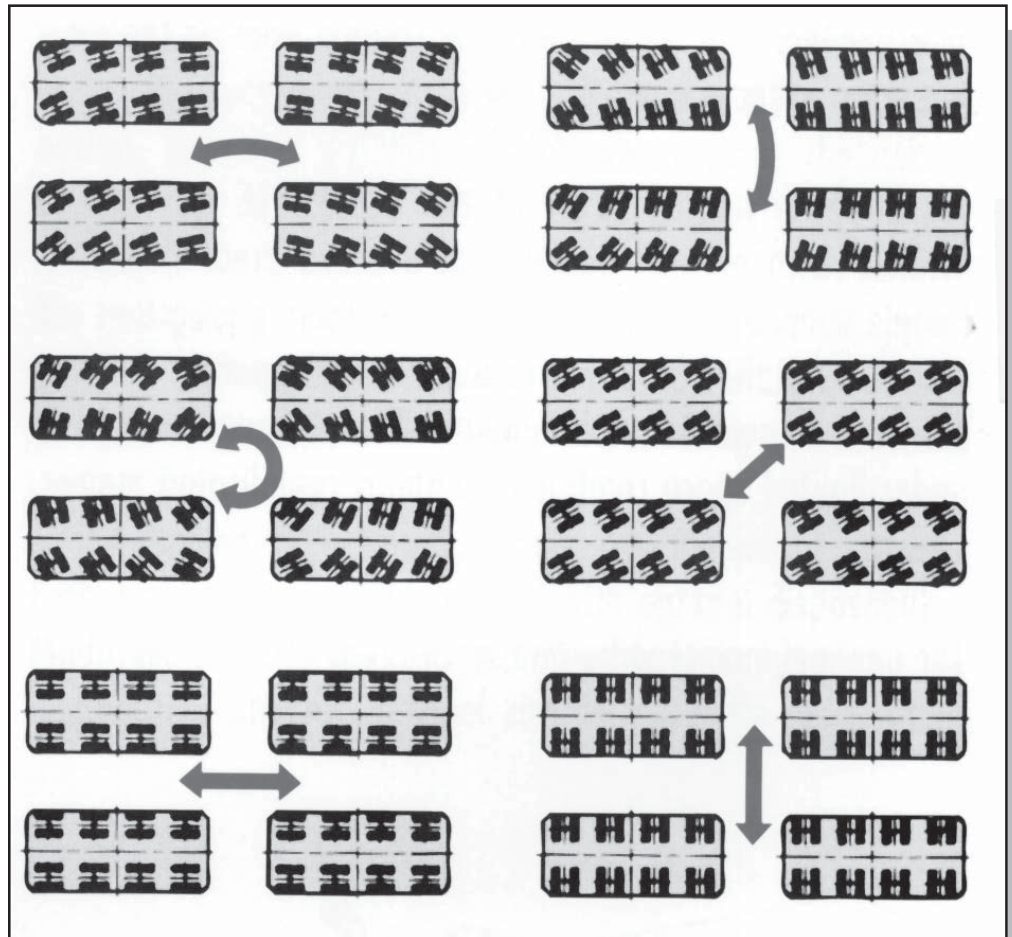

Figure 7.1-9 Examples of Steering Programs



Figure 7.1-10 KAMAG Self-Propelled Transporter



Figure 7.1-11 KAMAG Self-Propelled Transporters Hauling Module

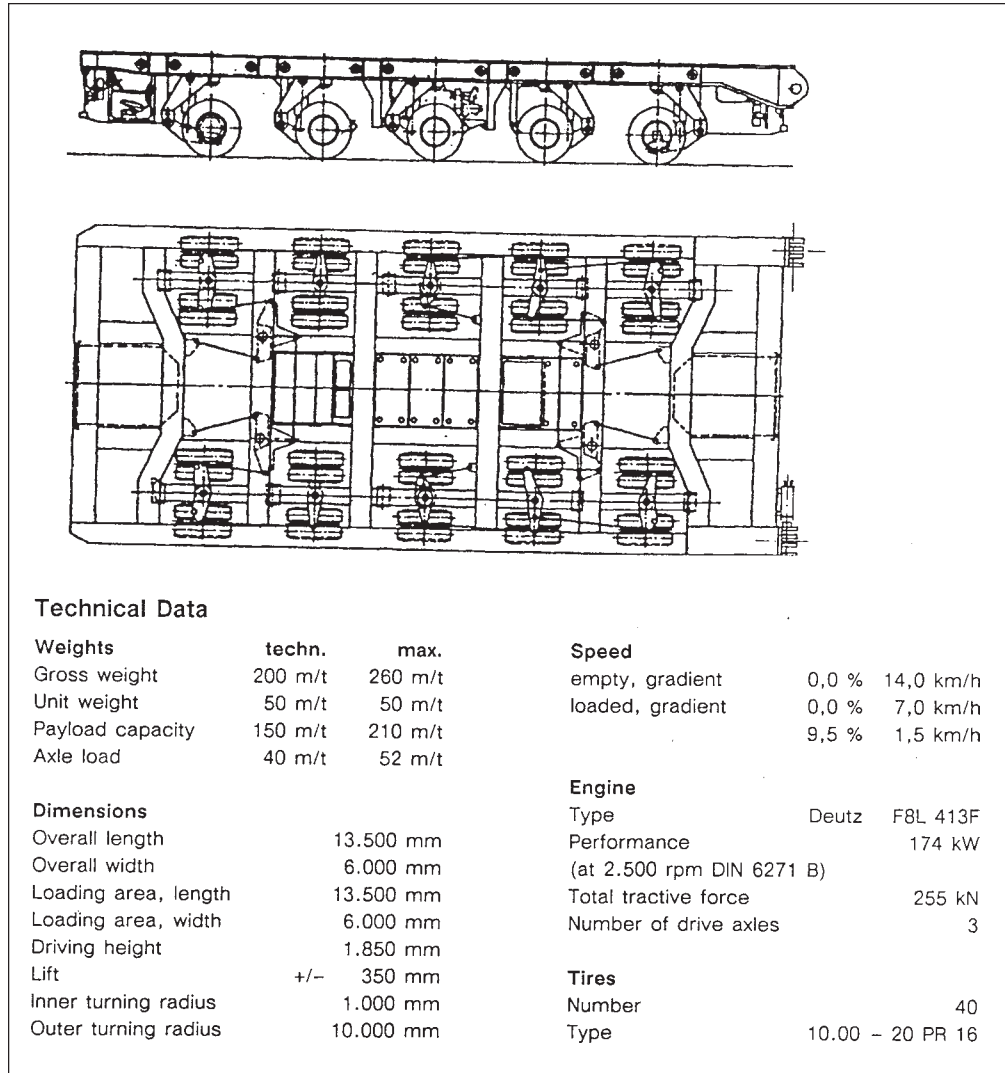

Figure 7.1-12 Plan View and Technical Details of Typical Self-Propelled Platform Trailer

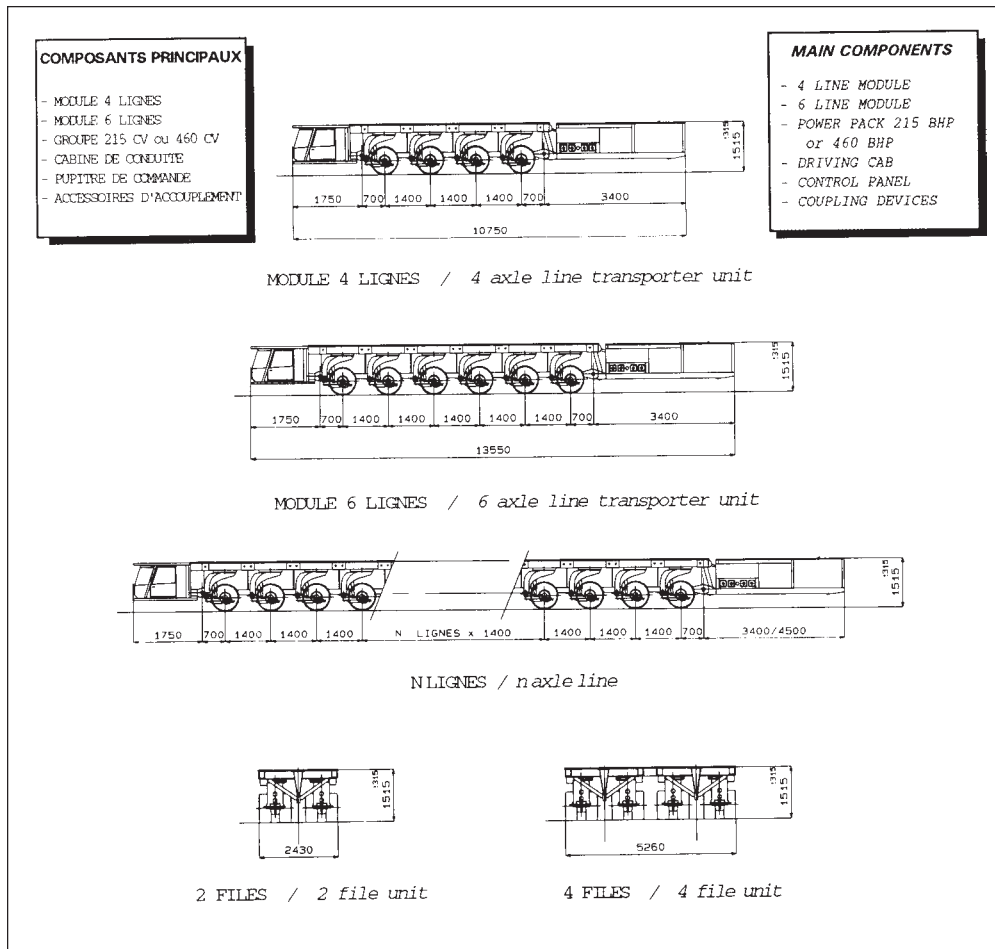

Figure 7.1-13 Four and Six Axle Self-Propelled Transporter Unit

7.1.3 Low-Bed/Multi-Axle Transporters

Low-bed/multi-axle transporters differ from hydraulic platform trailers in arrangement, performance, and suspension. Low-bed/multi-axle transporters rely on principles of statics to distribute load to the axles, whereas hydraulic platform trailers distribute the load to the axles with fluid (hydraulic oil) using Pascal's principle.

The load rests on the low steel deck or bed (low-bed) of the transporter. The bed is generally low to the ground to keep the load center of gravity low, thus enhancing stability. The bed is outfitted with front and rear goosenecks that are supported by front and rear bogies. The bogies consist of a series (or stack) of distributor beams that distribute the load to a multitude of axles. The axle spacing and locations can be varied by changing the length and arrangement of the distributor beams. This variety allows the transporter to meet state and local highway permit requirements for axle loadings, which is sometimes difficult to achieve economically with platform trailers.

A variation of the low-bed concept is to replace the low-bed and goosenecks with horizontal girders. The load hangs from these girders, which are supported front and rear by the bogies. A disadvantage of low-bed/multi-axle transporters is generally their length and lack of maneuverability. The load sits in the middle of the transporter, and the axles and distributor beams extend forward and rearward. Thus, the overall length of the vehicle can remain reasonably short for compact loads, but, for long loads, such as refinery vessels, the overall transporter length can become unreasonable. The turning radius for these transporters is generally very large. Their use on anything other than major highways may be restricted due to sharp turns.



Figure 7.1-14 Goldhofer High Bridge Girder with self-propelled multi-axle trailers

7.1.4 Crawler Transporters

Crawler transporters were used extensively in the past. However, because of the lack of maneuverability and travel restrictions on paved roads, crawler transporters have limited applications. Crawler transporters consist of a structural steel platform mounted on top of a standard crawler crane carbody.

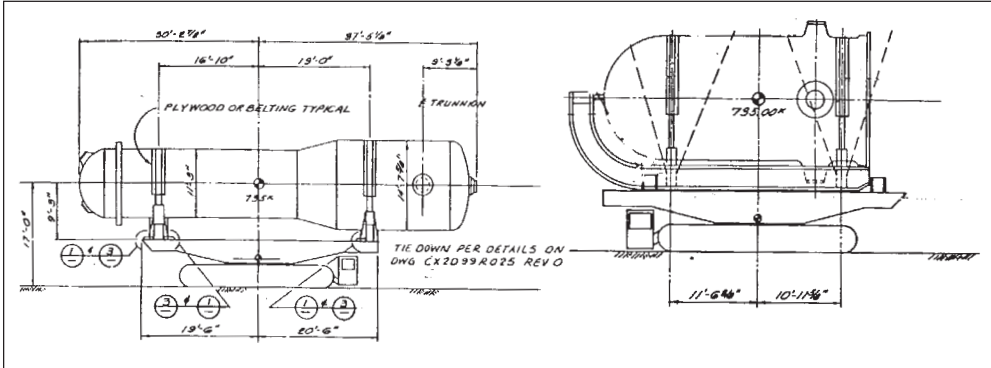

Figure 7.1-15 Crawler Transporter

7.1.5 Schnabel Cars

The Schnabel car configuration is suited for transporting heavy and bulky equipment via road or railroad. It offers unique advantages for keeping the center of gravity low to the ground, thus enhancing stability. This Schnabel arm consists of compression members at the top and tension members at the bottom. These members are pin connected to the vessel. In this manner, the Schnabel (or beak) arrangement uses the hauled equipment as a structural member to carry its own load. Equipment manufacturer such as General Electric and Westinghouse use Schnabel cars to transport generators, transformers, and other heavy, bulky equipment via rail.

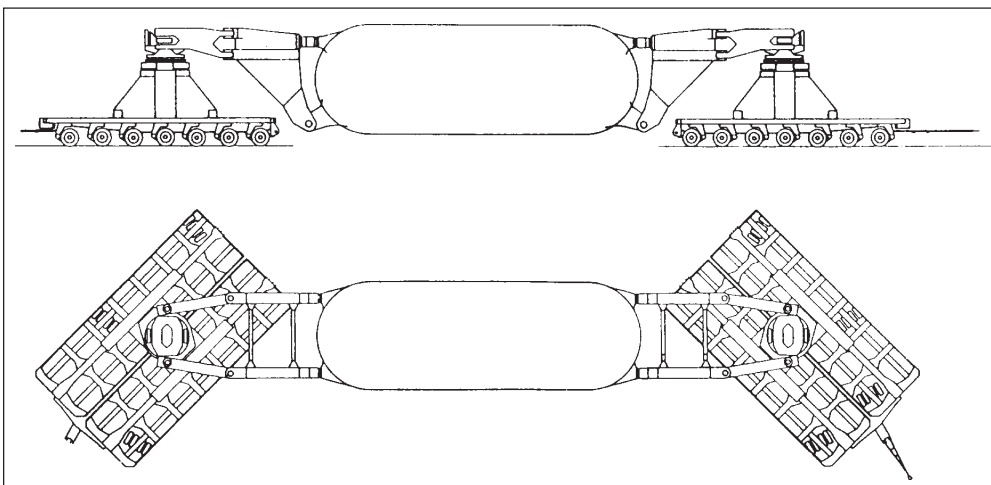

Figure 7.1-16 Schnabel Arrangement

7.2 LOAD STABILITY

Stability of heavy equipment being hauled on a trailer depends on the physical arrangement of the suspension system. When hauling, a trailer's axle configuration must be arranged to form a three-point, triangular suspension system. A three-point system is both stable and statically determinate.

For simplicity, consider a simple highway flatbed trailer. Two vertices of the stability triangle are defined by the centers of the rear axle supports of the trailer. The third vertex lies along the centerline of the trailer and is located at what is commonly known as the kingpin. To add more axles, designers need to add distributor beams and additional king pins at each vertex to branch the load to sub-bogies (jeeps). The sub-bogies must also adhere to the three-point arrangement. For hydraulic platform trailers, a three-point suspension is achieved by isolating the hydraulic suspension into three independent loops, as is described in Section 7.1.1.

To determine the stability triangle for a loaded transporter, follow this procedure. First, draw a plan view of the transporter and an outline of the payload, including the location of its center of gravity. Identify the key suspension points that will form the vertex of the stability triangle. Connect these points with straight lines to form the stability triangle. Arrange the payload center of gravity so that it lies within the triangle; if it does not, your arrangement is unstable and will tip over. Draw the **shortest** line perpendicular to any side of the triangle through the payload center of gravity. Draw an elevation view of the transporter and payload. In the elevation view, draw this short line, which will be the side opposite the “cant” angle. The adjacent side is formed by the line through the center of gravity normal to the plane of the transporter deck. In practice, the stability of a hauled payload is acceptable as long as the cant angle does not exceed 5 degrees. This must account for roadway and site conditions such as superelevation, roadway camber, grade changes, dynamic effects in turns, and travel speed. In addition to the geometric limitations of the suspension, structural and mechanical limitations need to be considered if a load is allowed to tilt. Statics calculations are required to determine the tilted load distribution to each of the three suspension vertices. The distribution will vary with center of gravity location and the amount of tilt. The forces must not subject the suspension components to excessive forces. For example, more load will shift to the “low” side of a tilted trailer and may overload the suspension on that side. Consequently the transporter must be de-rated when tilted.

To simplify the above procedure, many hydraulic platform trailer and transporter manufacturers have developed load stability charts. These charts are curves for different transporter configurations that give allowable transporter loads for various tilt angles and payload center of gravity heights. Figure 7.2-1 illustrates one of these curves for a Goldhofer trailer setup. Three items of information are needed; the chart is used to determine the fourth. Given the trailer arrangement, payload weight, and center of gravity height, the chart is used to determine the maximum tilt angle allowed. If the trailer arrangement, tilt angle, and center of gravity height are known, the chart is used to determine the heaviest payload.

Example 1

A contractor plans on using a single wide, 20-line transporter with a three-point suspension arrangement to haul a vessel that weighs 430 tons. The center of gravity of the vessel is 3 meters above the transporter deck. What is the maximum tilt angle that this transporter can safely negotiate?

Solution

From the chart, select the curve that represents 430 tons. Locate the center of gravity height of 3 meters along the vertical axis of the chart. Read the maximum tilt angle along the horizontal chart axis at the intersection of the 430-ton curve and the 3-meter line. This value is 5 degrees.

Example 2

Another vessel weighs 338 tons. With the same transporter from example 1, determine the maximum center of gravity height for transporting this vessel across the 5-degree slope.

Solution

There is no 338-ton curve on the chart; thus, we must use the 370-ton curve. (Interpolation between the curves is not recommended.) Reading the tilt angle of 5 degrees from the horizontal axis, it intersects the 370-ton curve at a load height of 5 meters.

For small amounts of tilt, a hydraulic platform transporter deck can be leveled as described earlier. Leveling the deck will equalize the load to each side of the transporter suspension, and the full, untilted, payload value can be used. For long hauls on public roads, this is usually not practical. Leveling is done manually and must be done with the transporter stopped or slowed down significantly.

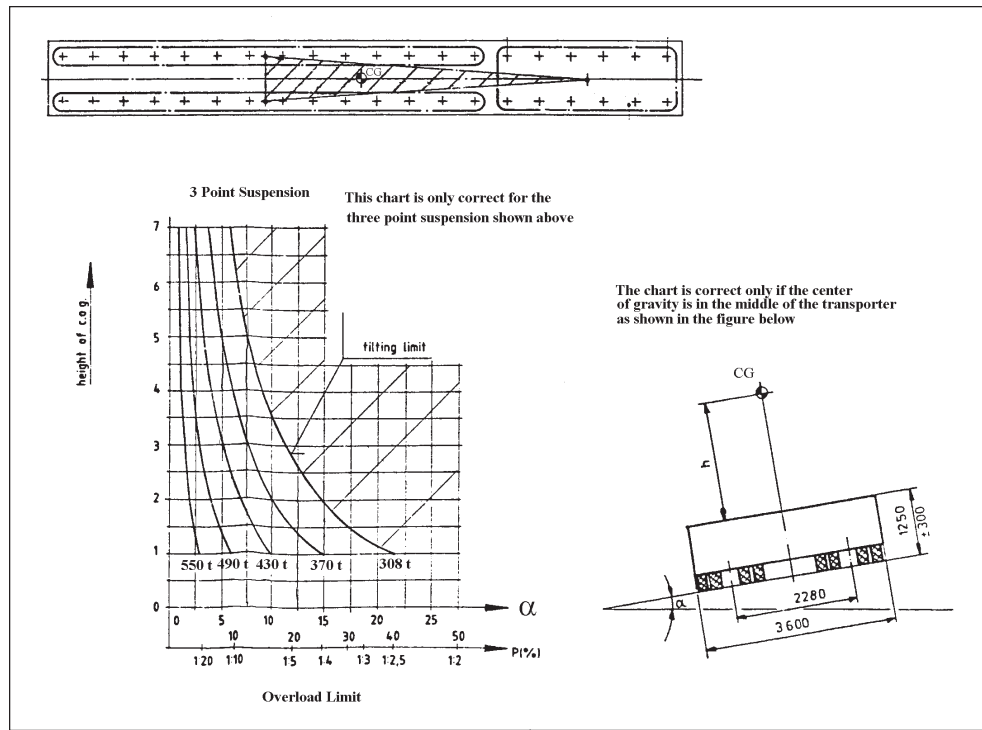

Figure 7.2-1 Load Capacity Reduction Due To Tilt

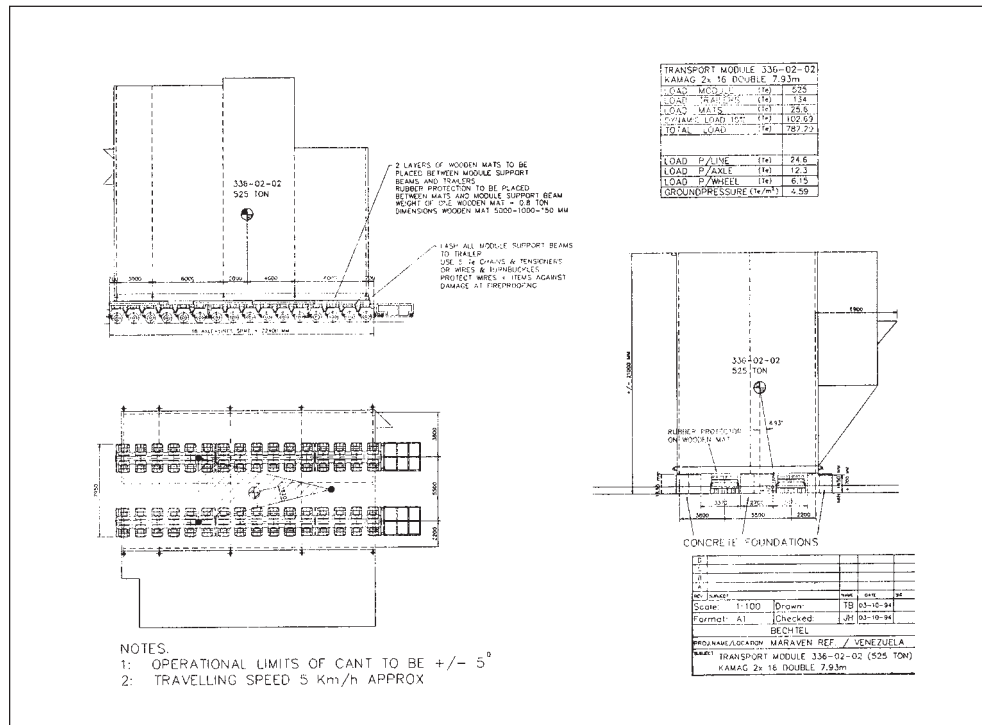

Figure 7.2-2 Cant Angle, Plan and Elevation Views

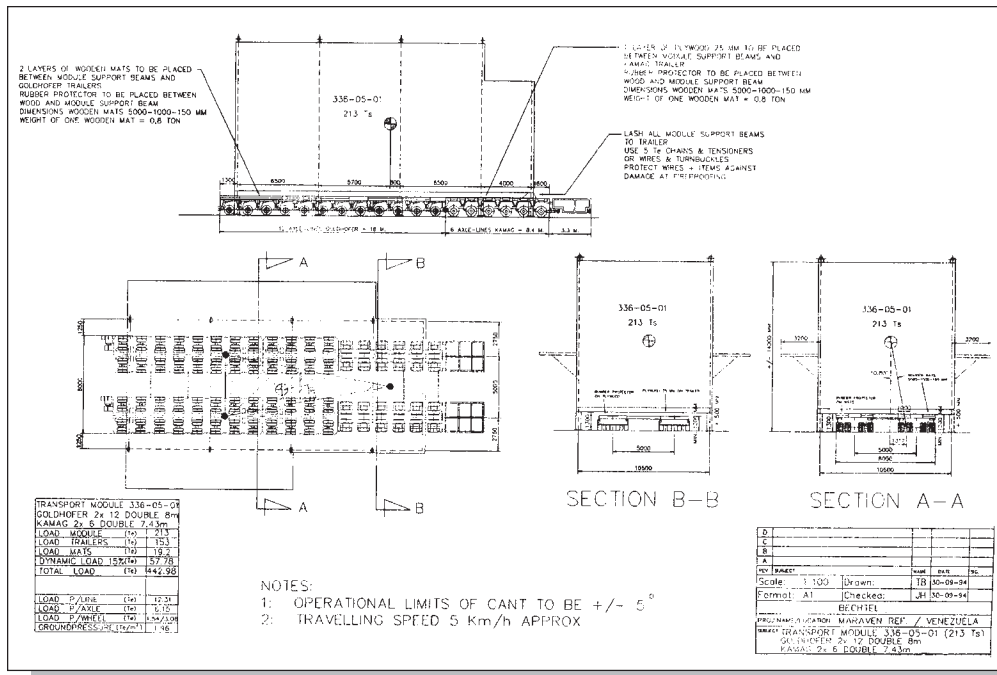

Figure 7.2-3 Cant Angle, Plan and Elevation Views

7.3 TRANSPORTER CAPACITY REDUCTION DUE TO SPEED

Hydraulic platform trailer payload capacity must be decreased as travel speed increases. Slower speeds offer larger capacities; faster speeds offer lower capacities. The primary reason for this reduction is, of course, dynamic effects. Impact loading is imparted to the transporter deck and suspension whenever the trailer hits a bump or discontinuity in the road. At high speeds, this impact force is greatly magnified. Figure 7.3-1 and the example below are manufacturer's data for a 4-line Scheurle trailer. Examination of the chart shows the significant decrease in capacity at high speeds.

Example

Payload capacity of a Scheurle 4 line, double wide trailer:

626 tons @ 20 km/hr

738 tons @ 5 km/hr

TECHNICAL DATA:				
SPEED:	62 km/h	20 km/h	5 km/h	3 km/h
TOTAL WEIGHT:	48 t	96 t	108 t	120 t
WEIGHT UNLOADED:	20 t	20 t	20 t	20 t
PAYLOAD:	28t	76t	88t	100t
AXLE LOAD:	4 x 12 t	4 x 24 t	4 x 28 t	4 x 30 t
TYRES:	32 x 7.50-15			
OVERALL LENGTH:	ca. 16825mm			
OVERALL WIDTH:	3000mm			
LOADING AREA:	3000 x 6420mm			
LOADING HEIGHT:	±300 1250mm			

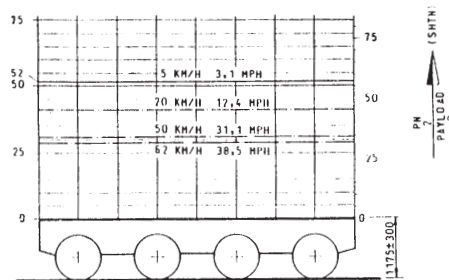

Figure 7.3-1

7.4 PAYLOAD SUPPORT LOCATIONS

Ideally, a hydraulic platform trailer's payload would be supported continuously along the length of the trailer's deck and apply a uniform load distribution. However, in most cases this ideal is impractical, and the payload is supported at two, three, or four discrete support points. Trailer manufacturers supply load charts, such as the one depicted in Figure 7.4-1, that show the permissible load capacities at various support locations along the length of the deck. For a two-point loading, the ideal support location is roughly at the quarter points. The permissible load decreases rapidly as the supports are moved closer to the center of the deck or as they are moved toward the ends of the deck. The reason is that the transporter deck consists of a longitudinal structural steel girder (or girders). The permissible loads at various locations are based on the structural capacity of the girder. Structurally, this is similar to a beam on an elastic foundation problem. The hydraulic suspension rams constitute the elastic foundation.

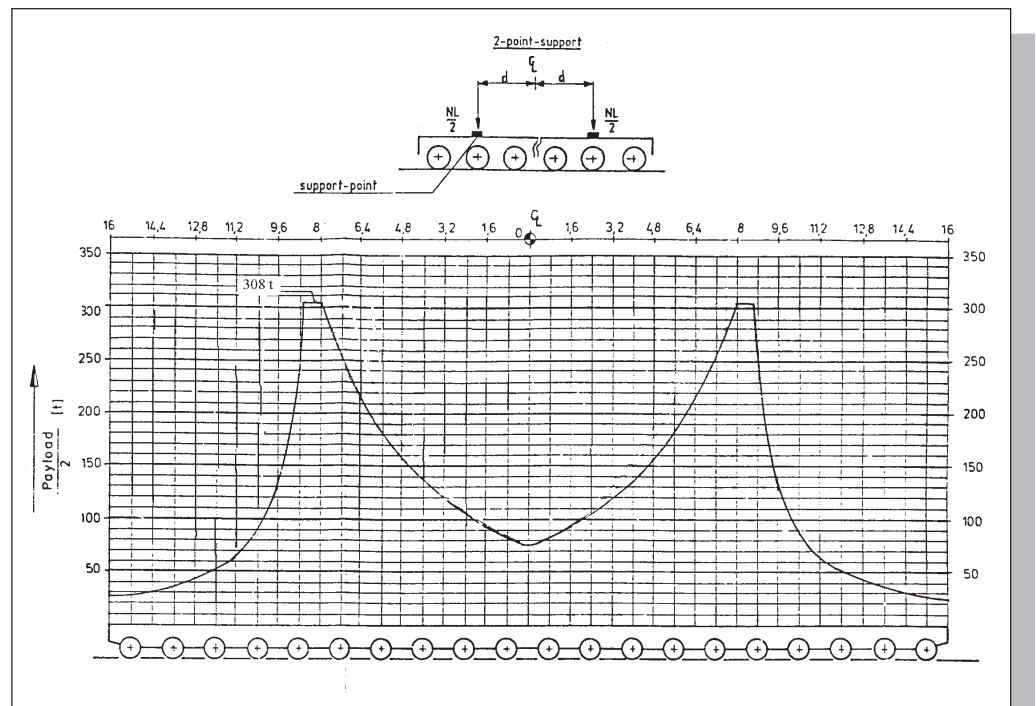

Figure 7.5-1 Allowable Loads For Various Deck Load Locations

7.5 WHEEL LOAD AND TIRE FOOTPRINT

Transporters and prime movers impart tire contact loads to their supporting surfaces. Tire bearing pressure information is required by the structural engineer and/or soils engineer for design or evaluation of ramps, short temporary bridges, culverts, and pavement. Many different tire widths and sizes are available on transporters. Generally, a tire's inflation pressure will be equal to its ground bearing pressure. The tire will squash the more it is loaded, thus increasing its bearing area proportionally. The load per unit area will remain constant. Figure 7.5-1 depicts bearing area curves for two different types of tires. Examine a given a tire width (type), wheel load, and inflation pressure on the chart. With this information, the bearing length can then be read from the horizontal axis.

Example

A contractor's transporter has four Continental 355/86-15 tires per axle, each with a width of 32 cm. The maximum axle load is 16 tons (4 tons per tire). The tires are inflated to 10 bar. Verify that the bearing pressure is equivalent to the tire inflation pressure.

Solution

From the graph, the longitudinal tire dimension is 12 cm at 10 bar inflation. This means that the bearing area is 12 cm x 32 cm = 384 cm². The load per tire is 16,000 kg/4 tires = 4,000 kg/tire. The ground bearing stress is 4,000 kg/384 cm² = 10.4 kg/cm² or approximately 10 bar.

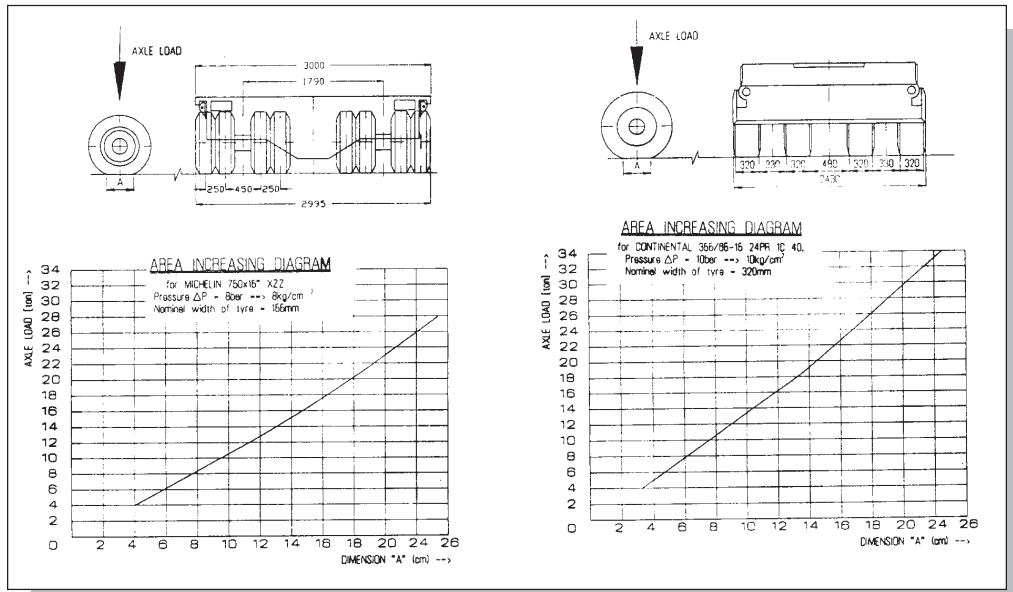

Figure 7.5-1 Tire Contact Area



8. Barging

This section discusses the following:

- Barge selection requirements
- Barge loading arrangement drawings
- Draft, trim, list, ballast, and stability analysis
- Barge forces and motions; roll, pitch, and heave calculations
- Sea fastening
- Roll on and roll off operation

8.1 FLAT DECK BARGE SELECTION REQUIREMENTS

Size and nature of the cargo includes:

- Area of deck occupied by the cargo
- Room to place sea fastenings
- Height of cargo and its center of gravity
- Cargo concentration on the deck

Route of travel includes:

- Inland river, Great Lakes, intracoastal waterways, and oceans
- Minimum navigable depth on the route
- Minimum width and or height; coastal waterways width and overhead bridges

Nature of cargo may effect selection of barge, including:

- Marine shipment of hazardous materials are governed by the ANSI N14.24-1985.

Dead weight scale includes:

- Cargo capacity that a barge can support
- Draft of barge because of cargo weight

8.2 LOAD LINE CERTIFICATE

The load line certificate specifies the maximum allowable draft at which a barge can operate. The American Bureau of Shipping issues the load line certificate on behalf of the U.S. Coast Guard.

TF	Tropical Freshwater Freeboard
F	Freshwater Freeboard
T	Tropical Water Freeboard
S	Standard Summer Freeboard
W	Winter Freeboard
WNA	Winter North Atlantic Freeboard

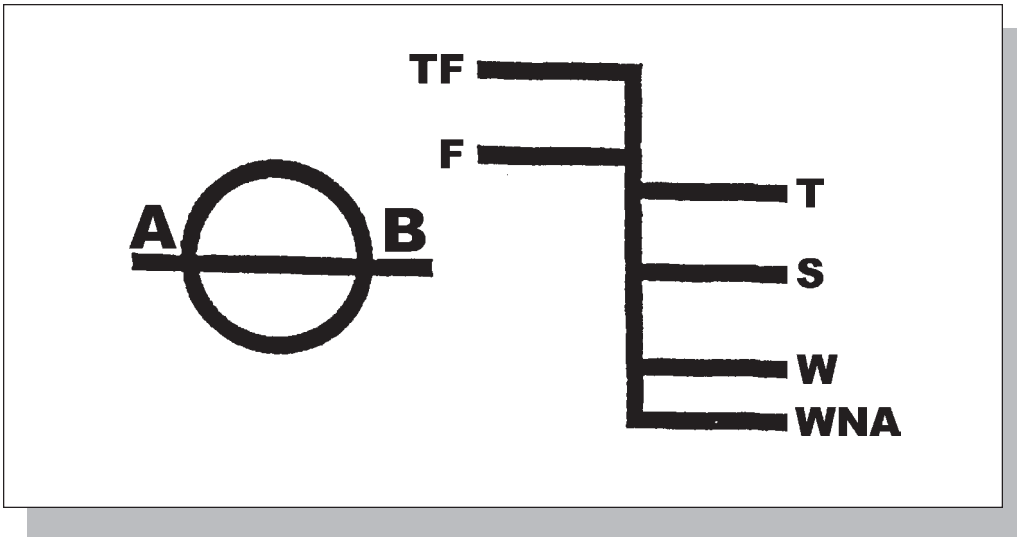

Figure 82-1 Load Line Markings

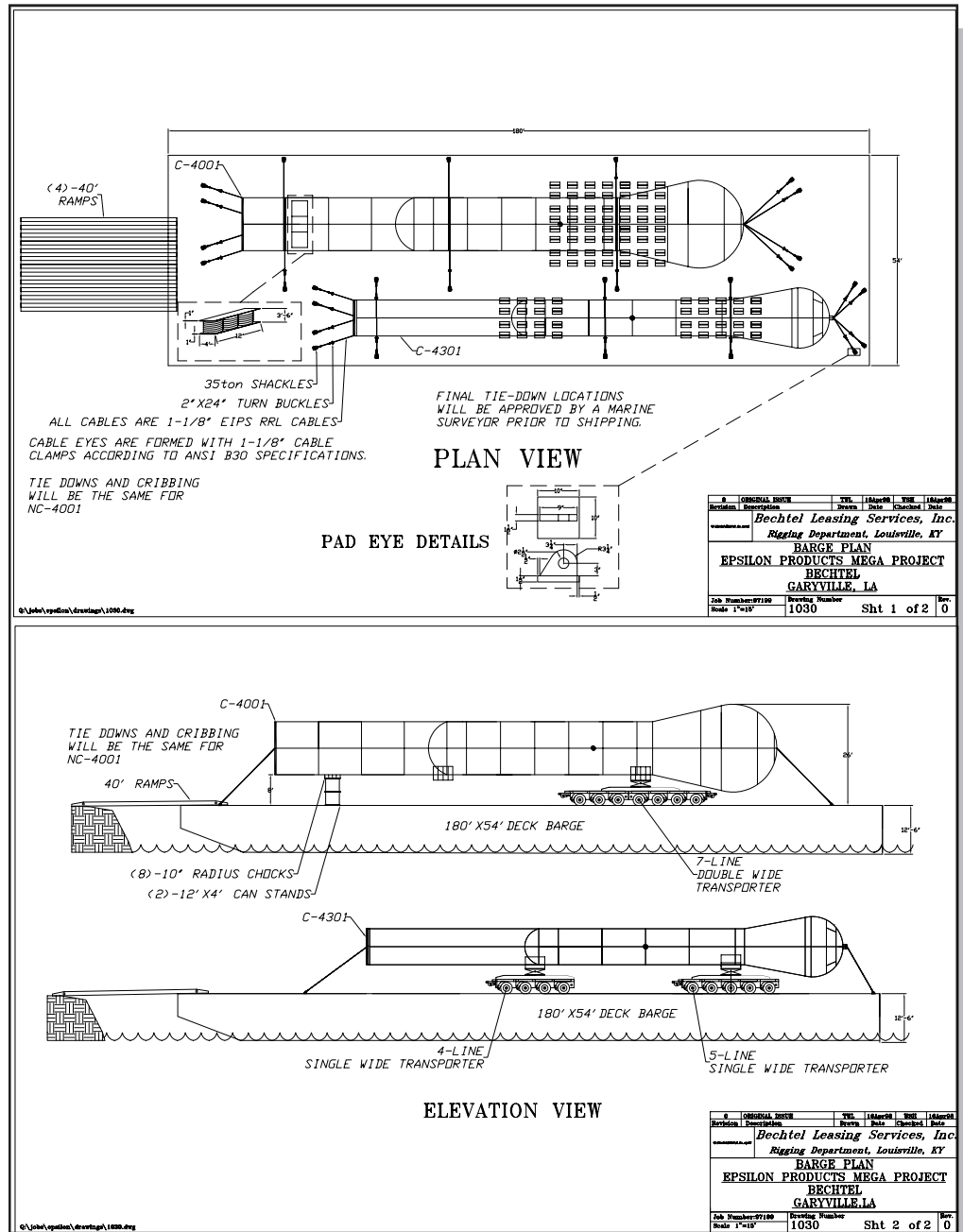

Figure 8.2-2 Barge Loading Arrangement

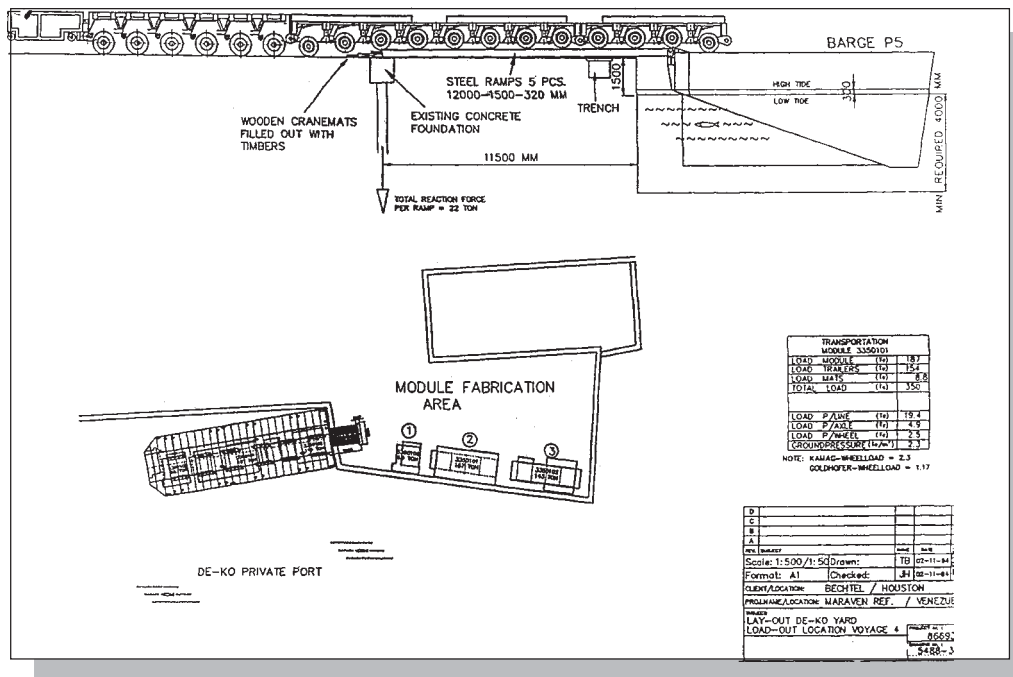

Figure 8.2-3

8.3 DRAFT AND TRIM

Draft includes the mean draft (measure near amidships), the forward draft (measured at bow), and the aft draft (measured at stern).

Trim includes the difference between forward and aft draft. Normally, the aft draft is greater for better towing and its called vessel is trimmed by the stern. Trim equal to 1/2 percent to 1 percent of the barge's length is considered acceptable.

Computation of trim is a function of two quantities: trimming moment and moment to trim 1 inch (longitude distances from bow).

l_{cg} = Longitudinal center of gravity of weight "w" in feet

LCB = Longitudinal center of buoyancy can be determined from hydrostatic curve or by calculation. Measured for bow locating center of gravity of the submerged volume of the barge.

W = Weights of individual items in long tons

D = Vessel displacement in long tons

Moment to trim 1 inch is a function of longitudinal metacentric height GML.

I_L = Moment of inertia of waterplane about transverse axis of barge in ft⁴

$$LCG := \frac{\sum (l_{cg} \cdot w)}{\Delta}$$

$$BM_L = \frac{I_L}{\Delta}$$

$$I_L = \frac{B \cdot L^3}{12}$$

$$GM_L = KB + BM_L - KG$$

$$MT1 := \frac{\Delta \cdot GM_L}{12 \cdot L}$$

Figure 8.3-1

8.4 LIST, TRANSVERSE ANGLE

The light weight (sum of barges, empty weight) of the barge is always on the longitudinal centerline as the center of buoyancy.

If the composite center of gravity of all loads on the barge is on the center, then the list is zero. If the center of gravity of the loads is not on the center, then the eccentricity creates an angle to the side called list.

Transverse center of gravity (TCG):

$$TCG := \frac{\sum (tcg \cdot w)}{\Delta}$$

w = Weight of individual items in long tons

TCG = Transverse center of gravity of weights “w” in feet

Δ = Vessel displacement in long tons

The list angle:

$$\theta := \tan^{-1} \left(\frac{TCG}{GM} \right)$$

Figure 8.4-1

8.5 BALLAST REQUIREMENT

The water ballast is used to correct the barge floating condition. Ballast water can improve floating condition; however, it reduces speed or other functions.

Figure 8.5-1 shows that the wing tank is one-half full of water ballast. When the barge is level and in calm water, the center of gravity of ballast water is at the center of the tank. As the barge heels, the surface of ballast remains level; however, the center of gravity of liquid will shift to the side and this shift will affect the stability. U.S. Coast Guard 46 CFR 170, Subpart I, addresses the corrections to be made to the stability calculation to account for free surface effects. The procedure computes an effective rise in center of gravity of the barge. This will reduce values for GM and GZ because lateral shift of G for rectangular ballast compartments

To calculate the rise in G to a virtual position G' because of the free surface effect:

l = Longitudinal dimension of the compartment

b = Transverse width of the compartment

Δ = Displacement (volume) of the barge

r = Ratio of specific gravity of the liquid in the tank to the liquid in which the barge is floating.

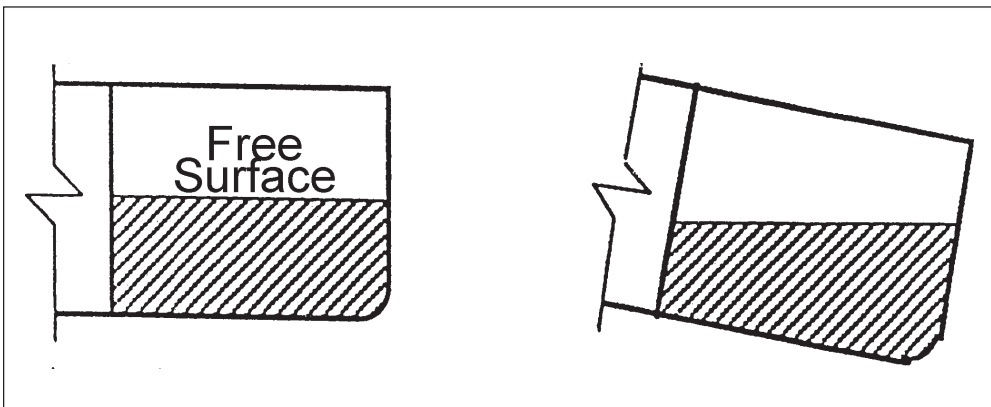

Figure 8.5-1

Ballast can increase draft, affect the center of gravity height of the laden barge, and reduce the value of GM (metacentric height) and the GZ (righting arm). The increase in draft will reduce the roll and pitch acceleration, which may reduce the cost of sea-fastening.

defined in U. S. Coast Guard publication 46 CFR 170 and 46 CFR 174. A barge tends to return to an upright position after being leaned by an outside force or measurement of the barge to resist capsizing. The number of different values needs to be computed by the naval architect or engineer to quantify the stability of the barge.

Initial stability or statical stability is the tendency of the barge to remain vertical in calm waters and return to vertical after having been displaced by a small angle of list, for example, 10 degrees.

Center of buoyancy B = Centroid of the submerged volume of the barge

Center of gravity G = Centroid of all weights on the laden barge, including the barge, ballast, and cargo weights

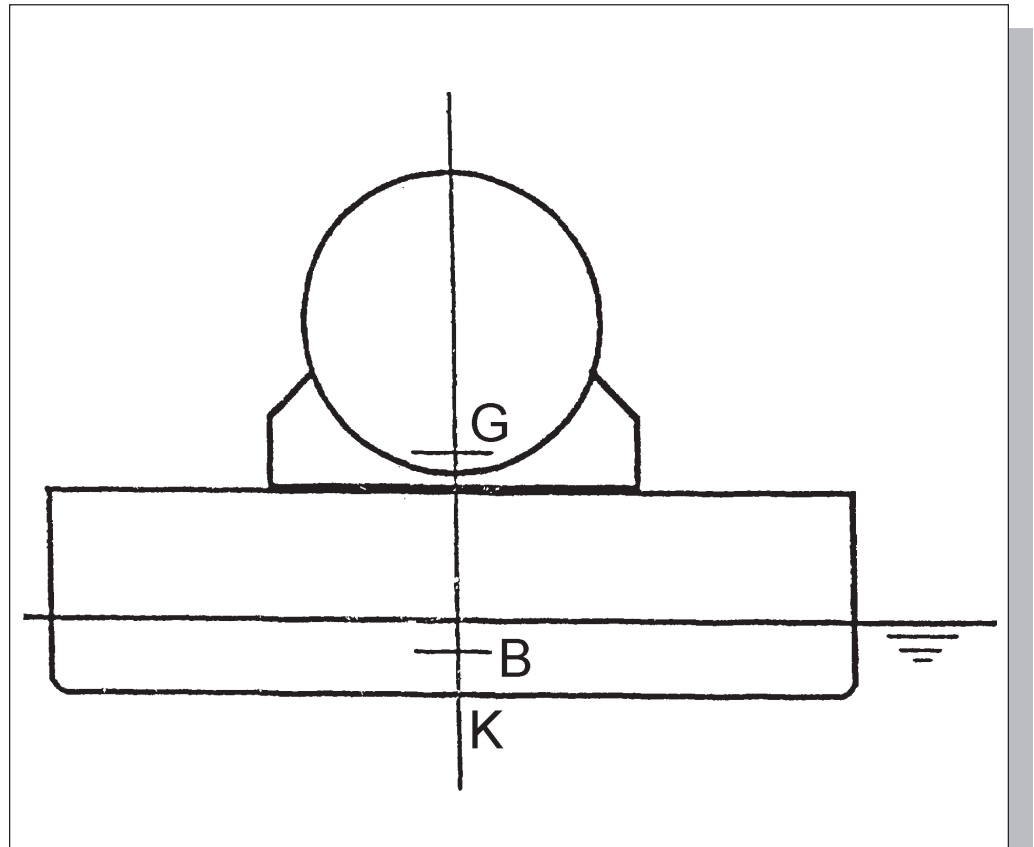

Figure 8.6-1

When the barge heels to starboard, the center of buoyancy shifts to the lower side, and if we draw a vertical line from B to intersect the barge centerline, we locate the transverse metacenter M.

Transverse metacenter is the point to which the center of gravity of the ship may rise and still possess positive stability.

As long as G is below M, the barge will return to vertical when listed by an outside force. GM is called metacentric height. Righting arm $GZ = GM \sin \theta$ horizontal distance between the vertical line from the center of gravity to when the line from metacenter to buoyancy.

Metacentric height: $GM = KB + BM - KG$

Righting arm: $GZ = GM \sin \theta$ horizontal distance between vertical line from the center of gravity to when the line from metacenter to buoyancy

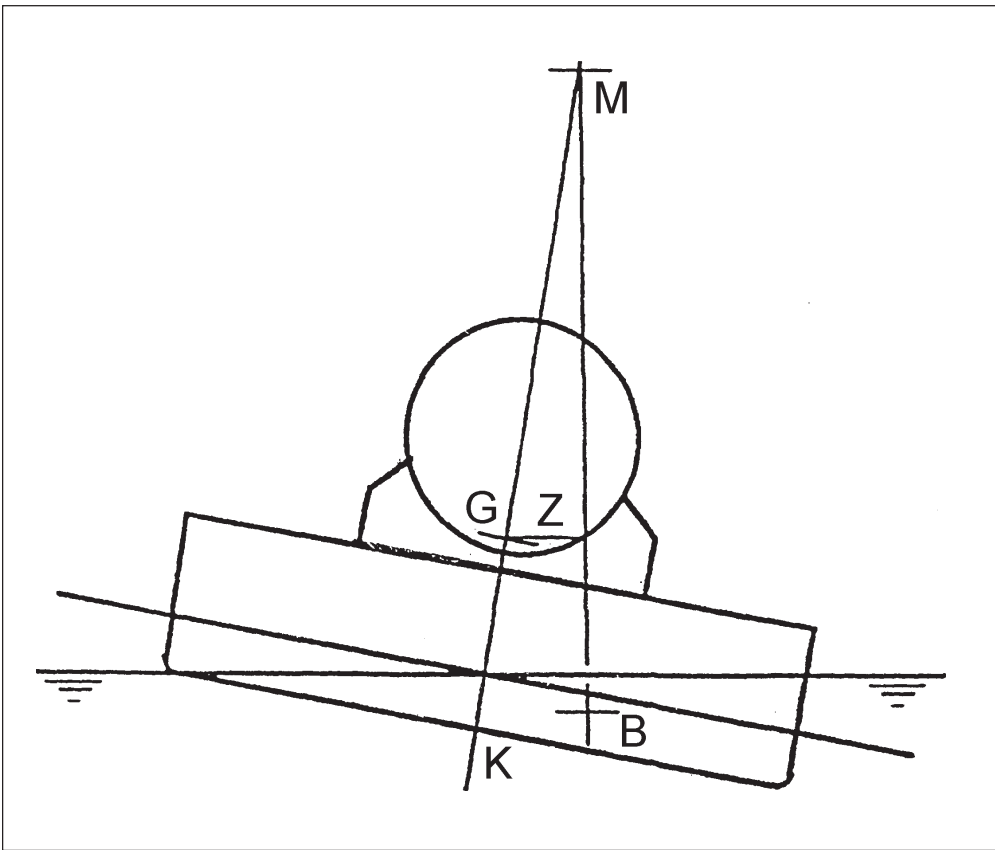

Figure 8.6-2

GZ is 0 when the barge is level; as the barge heels, GZ increases to maximum and then drops back to 0.

The righting arm curve shows that the maximum righting arm is about 10 feet and occurs at an angle of 25 degrees.

The area under the curve to this point is dynamic stability; it is approximately 170 feet-degrees. The angle that GZ returns to 0 is 72 degrees and is called the range of stability. Items need to be computed when the stability of a barge is assessed.

1. Maximum righting arm
2. Angle of heel at which maximum righting arm is determined
3. Angle of heel when the righting arm becomes 0
4. Dynamic stability expressed in foot-degree

Righting Arm Curve

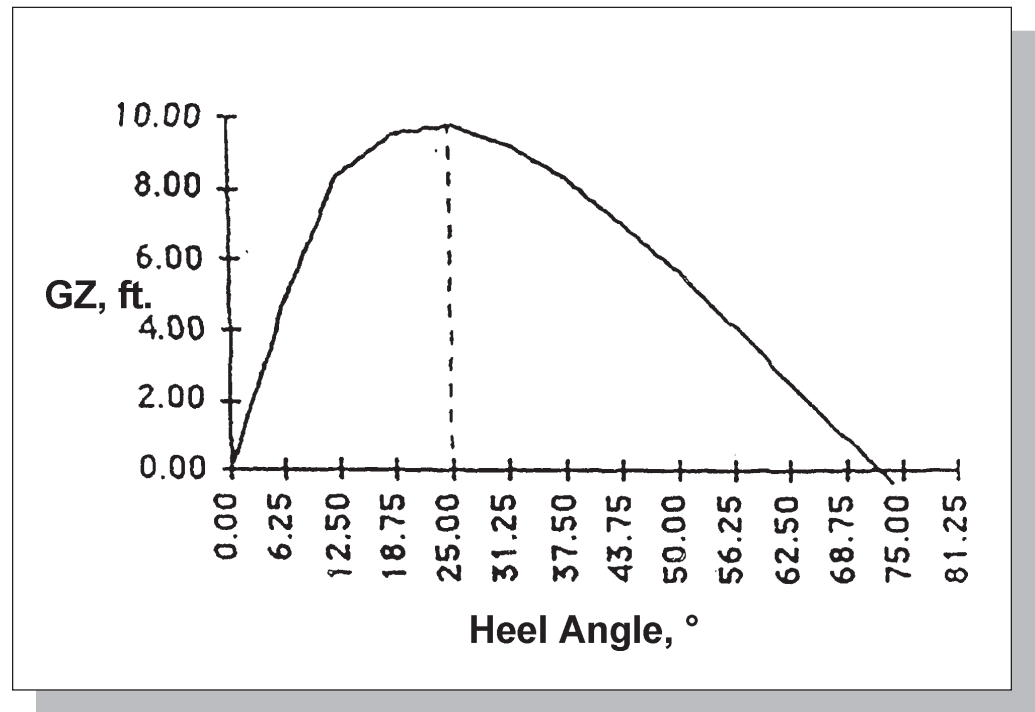

Figure 8.6-3

Displacement of barge Δ = total weight in metric tonnes (barge ~empty weight + weight of all cargo onboard).

Moment summation method is used to locate the center of gravity of the barge in 3D.

Vertical center of gravity: KG (always measured up from the keel)

Transverse center of gravity: TCG (measured relative to the longitudinal centerline)

Longitudinal center of gravity: LCG (measured from the bow)

Displacement of barge in terms of volume of water it displaces: $=\Delta * \rho$

Δ = Vessel displacement in long tons

P = 35.00 cubic feet per long ton for saltwater and 35.9 cubic feet for fresh water

T = Draft, determined from deadweight scale. Height of center of buoyancy: $KB = 0.53 * T$

I_t = Moment inertia of waterplane about longitudinal axis of the barge in ft^4

(L_{wl} = Length of waterline)

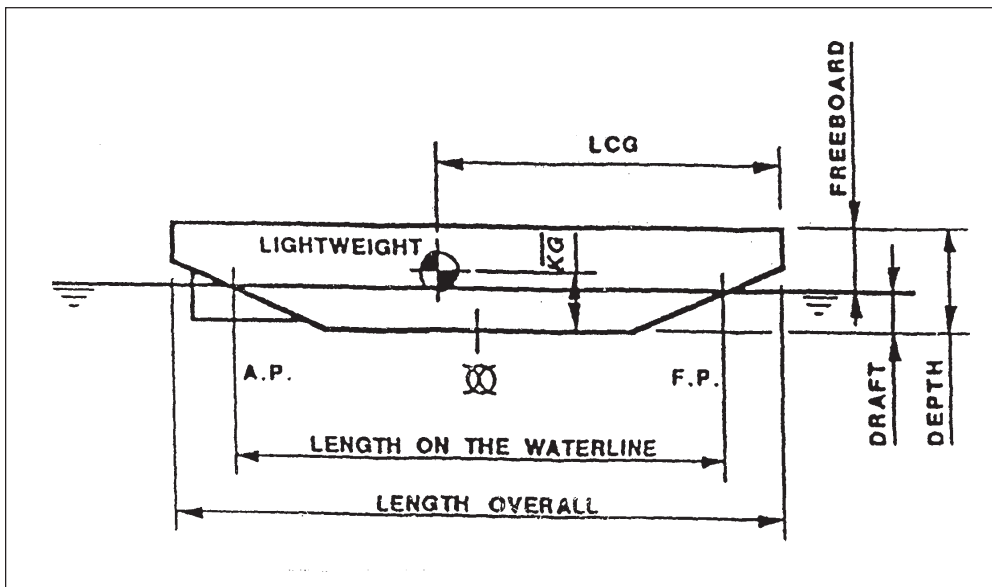

Figure 8.6-4

The righting arm $GZ = GM \times \sin \phi$. The major effort to construct the righting arm curve is to locate the center of buoyancy for various angles of inclination. The objective is to locate the center of buoyancy in terms of y and z , and then the righting arm $GZ = z \times \cos \phi + y \times \sin \phi - KG \times \sin \phi$.

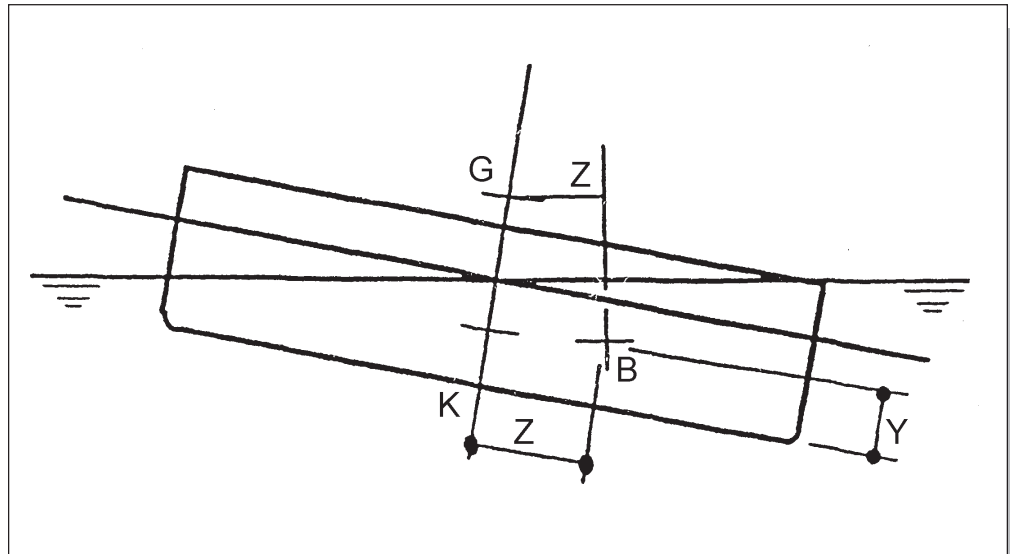

Figure 8.6-5 Heeled Center of Buoyancy

$KM/B = CIT/12 CB (B/T) + CKB (T/B)$: This equation is plotted to show the relationship between the height of metacenter above the keel and the draft. B equals beam (width of barge).

The curve shown below includes the height of the center of buoyancy expressed as KB/B calculated for the Loveland barge 1721. The height of metacenter drops significantly as the draft increases.

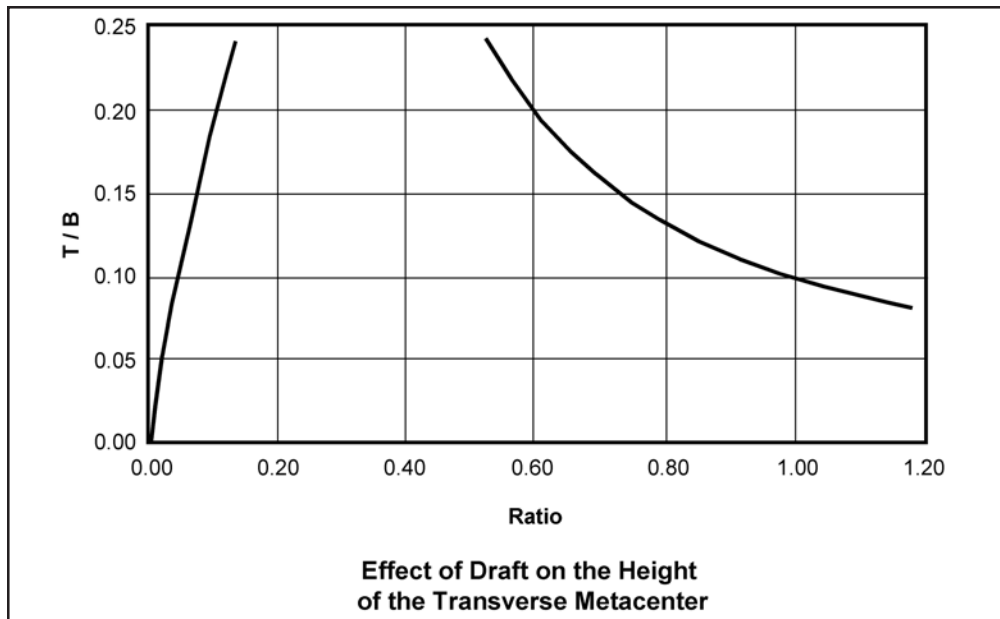

Figure 8.6-6 Effect of Draft on the Height of the Transverse Metacenter

Example:

Determine the height of the transverse metacenter; KM for the Loveland barge 1721 and barge Paul Bunyan using the curve. In both cases the mean draft is 5 feet.

Solution:

The beam for Loveland 1721 is 43'-6". The draft/beam ratio T/B is 0.115. Reading from the graph, the value for the KM/B equals 0.88. Therefore, KM equals 38.3 feet.

For Paul Bunyan, the beam is 54 feet; T/B is 0.093; curve KM/B is 1.04; therefore, the KM is 56.2 feet.

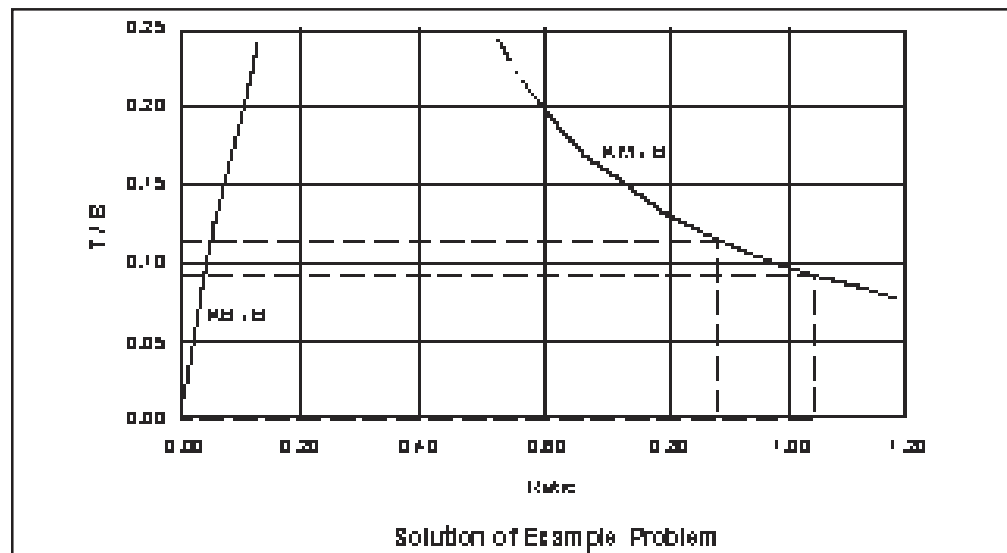

Figure 8.6-7 Solution of Example Problem

8.7 INTACT STABILITY REQUIREMENT

The Coast Guard requirements for stability are published in 46 CFR 170 through 174, Part 170. It establishes the requirement for all vessels, and Part 174 under Subpart B addresses requirements for the deck cargo barges. 46 CFR 170 defines various requirements in the construction of vessels. An ABS loadline certificate and classification assure that the barge meets or exceeds the requirements.

One calculation is defined in its part; the definition of initial stability is defined by the metacentric height GM:

Value of P varies with the 6 type of travel routes.

The minimum required is:

P for ocean service, Great Lakes, or service on exposed water $P = 0.005 + (L / 14,200)^2$ long tons/square feet

L = Length between perpendiculars in feet

A = Projected lateral area in square feet of the portion of the barge and deck cargo above the waterline

H = The vertical distance in feet from center of A to the center of underwater lateral area or approximately one-half of the draft

W = Displacement in long tons

T = 14 degrees or the angle of heel at which one-half of the freeboard to the deck edge is immersed, or whichever is less. Value of the P in the above equation relates to a wind speed of approximately 55 knots for ocean service, 45 knots for Great Lakes service, and 40 knots for protected waters.

Table 8.7-1 U.S. Coast Guard Table 174,020

Category (1)	Beam/Depth Ratio (2)	Draft/Depth Ratio (3)
A	3.00 to 3.74	Equal to or less than 0.70
B	3.75 to 3.99	Equal to or less than 0.72
C	4.00 to 4.49	Equal to or less than 0.76
D	4.50 to 6.00	Equal to or less than 0.80

8.8 DAMAGED STABILITY REQUIREMENT

The U.S. Coast Guard has no regulation that defines stability requirements in a damaged condition for deck barge cargo. ANSI N14.24-1985 requires determination of the stability analysis to assure that the vessel or cargo will not be lost. In this case, assumptions are made that one or more watertight compartments are damaged.

Two calculation methods are used: 1) Lost buoyancy method and 2) Added weight method. The water in the flooded compartment will increase weight and draft. If the flooded volume is not symmetrical, list and trim need to be calculated.

8.9 BARGE MOTION AND FORCES

Barge stability needs to be analyzed to assure that the barge will always return to an upright position after being moved away because of wind and wave forces. Six degrees of freedom of motion may occur. Three degrees are rotational—roll, pitch, and yaw—and three are linear. Among these six forces, roll, pitch, and heave are significant forces. The other three forces, surge, yaw and sway, are small and insignificant.

In practice for transportation of heavy equipment on a flat deck barge, two loading conditions of wave-induced motion forces are considered: 1) Beam seas (wave traveling cross the width of the barge) and 2)†Head seas (wave traveling along the length of the barge), and combines heave and pitch forces.

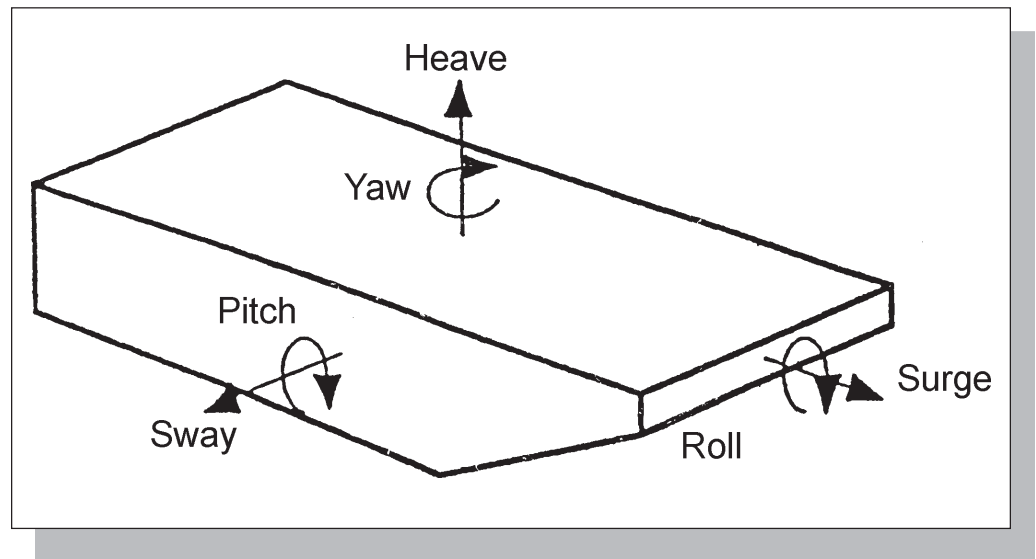

Figure 8.9-1

8.10 CALCULATION OF FORCES DUE TO ROLL

The barge will roll about on its longitudinal axis and roll at the period of the waves. The most severe motion will be when the period of waves is at or near the barge's natural period.

$T_r = N$. natural period in roll

$$T_r = \frac{2 * \pi * k_x}{\sqrt{g}} \sqrt{\frac{T + X_A}{GM}} \quad K_x = \sqrt{\frac{I_X}{\lambda}}$$

$$X_A = \frac{(B/T)^2}{100}$$

GM = Metacentric height

K_x = Radius of gyration of mass

X_A = Added mass coefficient

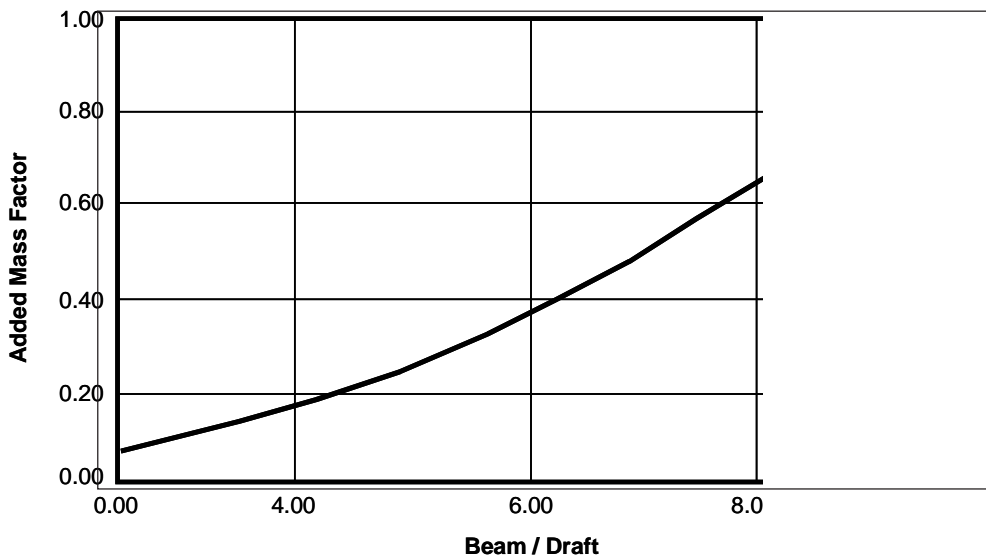

Figure 8.10-1

Having calculated the period of roll, we can determine the two roll forces that act on the cargo because of these motions: radial force and tangentially force.

F_r = Radial force, small in magnitude and ignored

F_t = Tangentially force

$$F_{T_p} = W^* \left[\frac{4 * \pi^2}{T_r^2} * \frac{Y}{g} * \frac{\phi * \pi}{180} + \sin(\phi) \right] \quad F_{T_n} = W^* \left[\frac{4 * \pi^2}{T_r^2} \right]$$

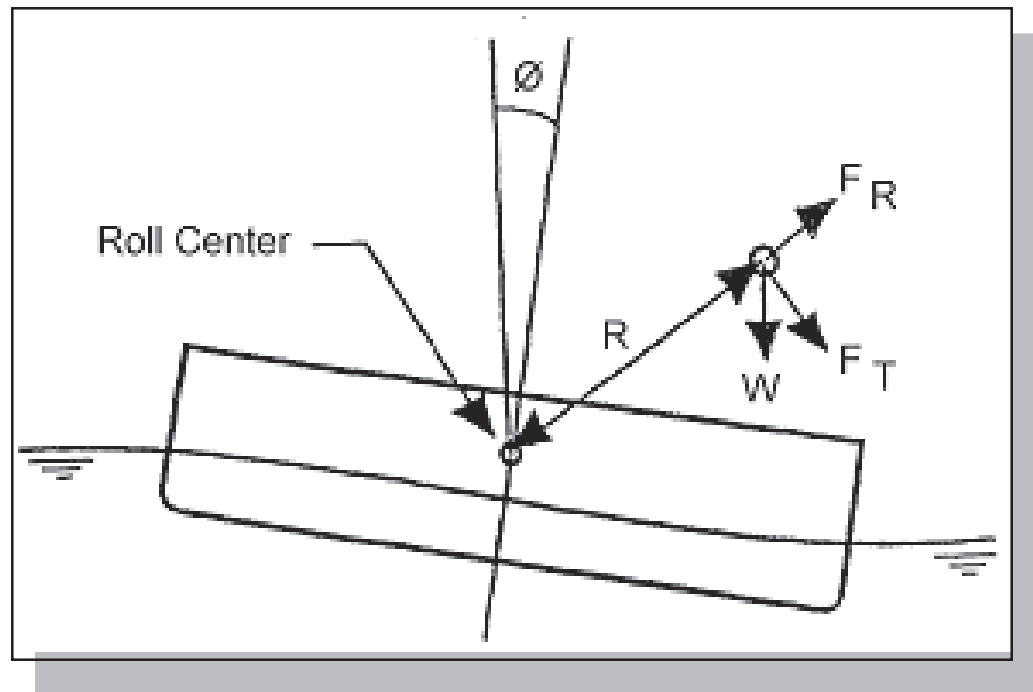

Figure 8.10-2

8.11 CALCULATION OF FORCES DUE TO PITCH

Computation of forces due to pitch requires the expression of various equations in terms of longitudinal rather than transverse.

$$T_P := \frac{2 \cdot \pi \cdot K_P}{\sqrt{g}}$$

GM_L = Metacentric height

K_z = Radius of gyration of mass

XA = Added mass coefficient assumed at 25% of vessel length

$$F_{(T_p)} = \bullet W \cdot \left(\frac{4 \cdot \pi^2}{T_p^2} \cdot \frac{Y}{g} \cdot \frac{\phi \cdot \pi}{180} \cdot \sin(\phi) \right) \quad F_{(T_n)} = \blacksquare W \cdot \left(\frac{4 \cdot \pi^2}{T_p^2} \cdot \frac{X}{g} \cdot \frac{\phi \cdot \pi}{180} \cdot \cos(\phi) \right)$$

Pitch angle 0 = 4 deg. for protected waters
 6 deg. at seas near coastlines
 10 deg. in the open seas

8.12 CALCULATION OF FORCES DUE TO HEAVE

Vertical force is created due to heave. A barge in heave mode is like a suspended weight from a spring. The stiffness of the spring is a standard quantity in tons per inch immersion. The TIP value is based on number of long tons required to increase draft by 1 inch.

For saltwater $TPI := \frac{A_w}{420}$ For freshwater $TPI_{fw} = \frac{A_w}{431}$

A_w = Area of water plane in square feet

T_h = Natural period in heave $T_h = 2\pi \cdot \sqrt{\frac{\Delta \cdot (1 + x_A)}{12 \cdot g \cdot TPI}}$

x_A = Added mass factor

F_h = Heave force up or down
 Y_h = Amplitude of heave in feet $F_h = \frac{TPI \cdot 12 \cdot Y_h}{\Delta \cdot (1 + x_A)} \cdot W$

Δ = Displacement in long tons

W = Weight of cargo in long tons

Table 8.12-1 Annual Sea States in the Open Ocean, Northern Hemisphere

Sea State Number (1)	Significant Wave Height (Feet) (2)	Sustained Wind Speed (Knots) (3)	Percentage Probability (4)	Model Wave Period (Seconds)		Wave Length (Feet) (7)
				Range (5)	Most Probable (6)	
0-1	0.0 – 0.3	0 – 6	0.0	-	-	-
2	0.3 – 1.6	7 – 10	5.7	3 – 15	7	251
3	1.6 – 4.1	11 – 16	19.7	5 – 15.5	8	328
4	4.1 – 8.2	17 – 21	28.3	6 – 16	9	415
5	8.2 – 11.1	22 – 27	19.5	7 – 16.5	10	512
6	13.1 – 19.7	28 – 47	17.5	9 – 17	12	737
7	19.7 – 29.5	48 – 55	7.6	10 – 18	14	1,004
8	29.5 – 45.5	56 – 63	1.7	13 – 19	17	1,480
>8	>45.5	>63	0.1	18 – 24	20	2,048

Column 7 is calculated based on the relationship between the wave length L_w and the wave period T_w :

$$L_w = \frac{g}{2\pi} \cdot T_w^2$$

8.13 SEA FASTENING

Sea fastening considerations include:

- Layout of the barge deck and cargo on the barge
- How to load the barge—by crane or by multi-ton transport
- Ramps
- Load spreaders
- Area need for sea fastening

8.14 AREA NEEDED FOR SEA FASTENING

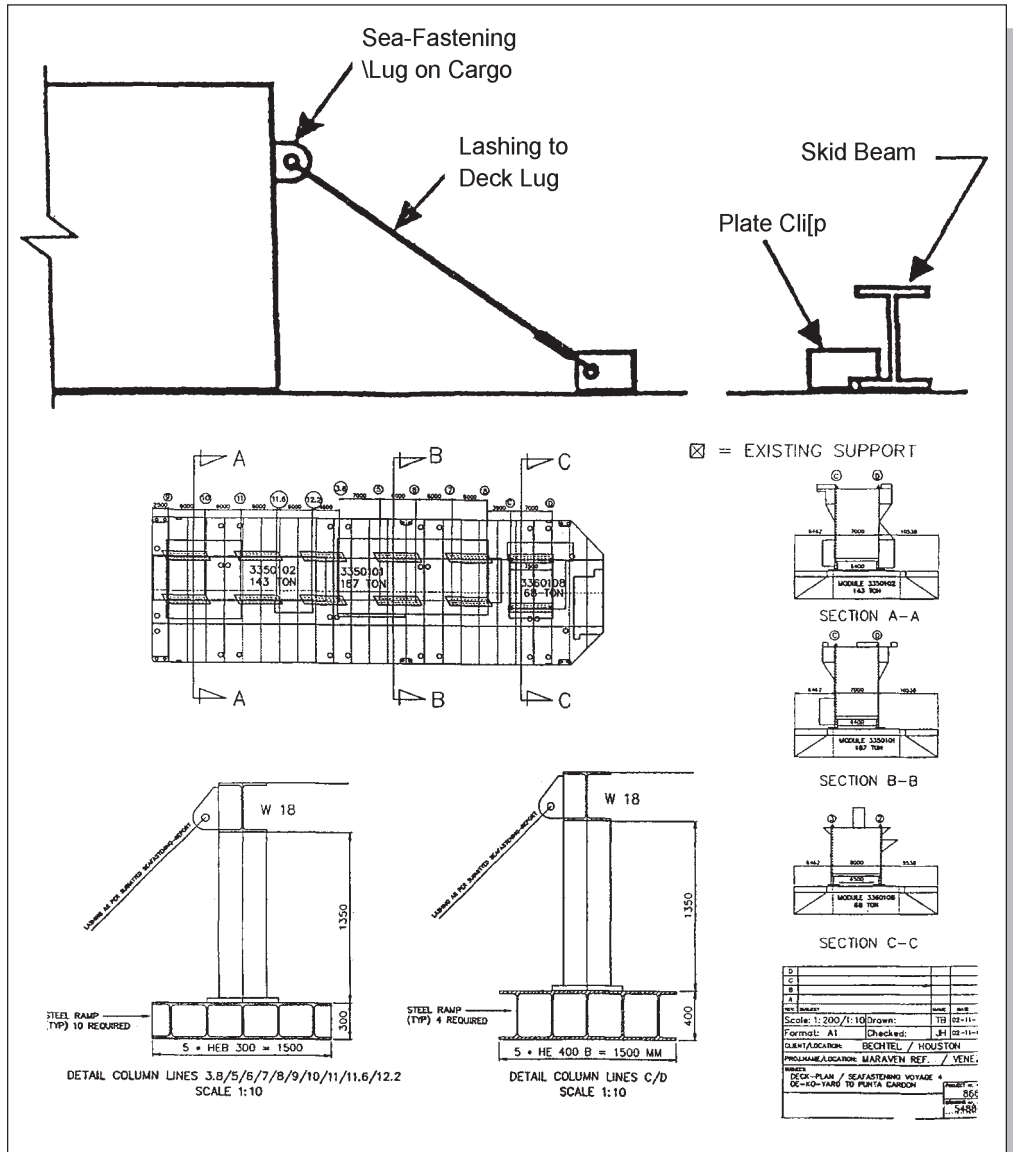

Figure 8.14-2

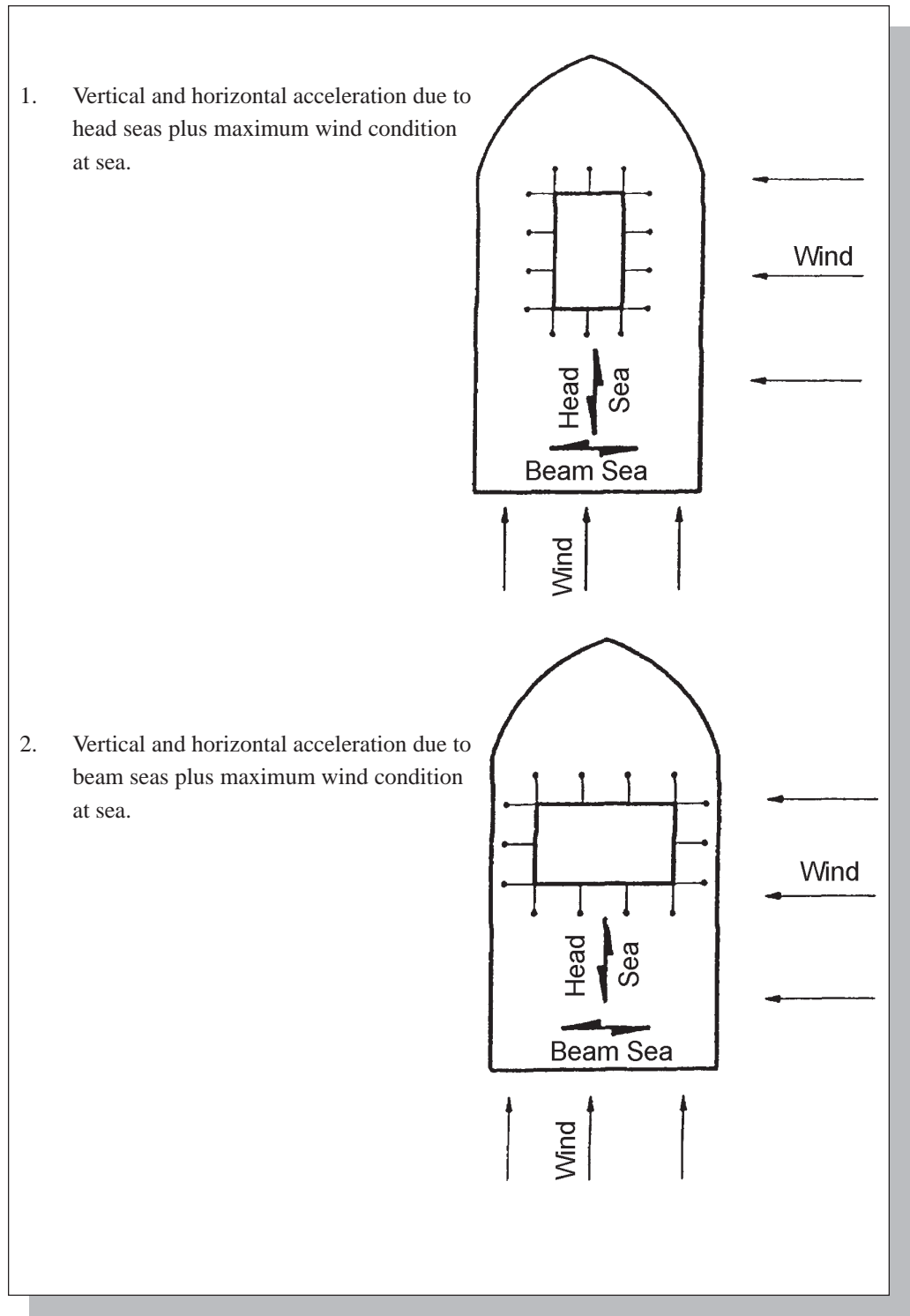

Figure 8.14-3 Sea Transport Condition and Design Horizontal Acceleration Factors

8.15 SEA TRANSPORT DESIGN CONDITION—U.S. COAST TO PUNTO FIJO

For head sea:

Vertical and horizontal acceleration plus maximum wind

$$DL + VAH + HAH + WL$$

For beam sea:

Vertical and horizontal acceleration plus maximum wind

$$DL + VAB + HAB + WL$$

In each equation:

Vertical acceleration (VAH) = .23 g due to head sea

Vertical acceleration (VAB) = .25 g due to beam sea

Horizontal acceleration (HAH) = varies (see chart) due to head sea

Horizontal acceleration (HAB) = varies (see chart) due to beam sea

Maximum wind at sea considered 92 mph (147 kph)

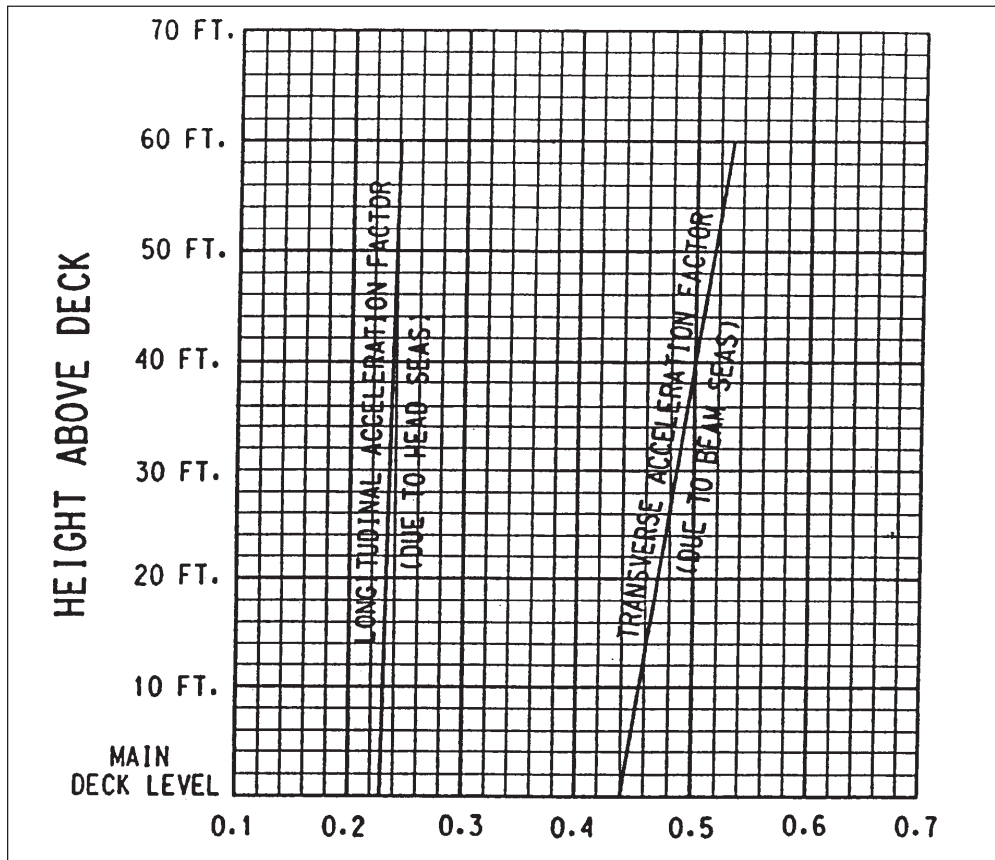

Figure 8.15-1 Design Horizontal Acceleration Factor (from United States to Punto Fijo)

Note: To be used for design of all unit C-1 modules

8.16 SEA TRANSPORT DESIGN CONDITION VENEZUELA TO PUNTO FIJO

For head sea:

Vertical and horizontal acceleration plus maximum wind

$$DL + VAH + HAH + WL$$

For beam sea:

Vertical and horizontal acceleration plus maximum wind

$$DL + VAB + HAB + WL$$

In each equation:

Vertical acceleration (VAH) = .12 g due to head sea

Vertical acceleration (VAB) = .20 g due to beam sea

Horizontal acceleration (HAH) = varies (see chart) due to head sea

Horizontal acceleration (HAB) = varies (see chart) due to beam sea

Maximum wind at sea considered 80 mph (128 kph)

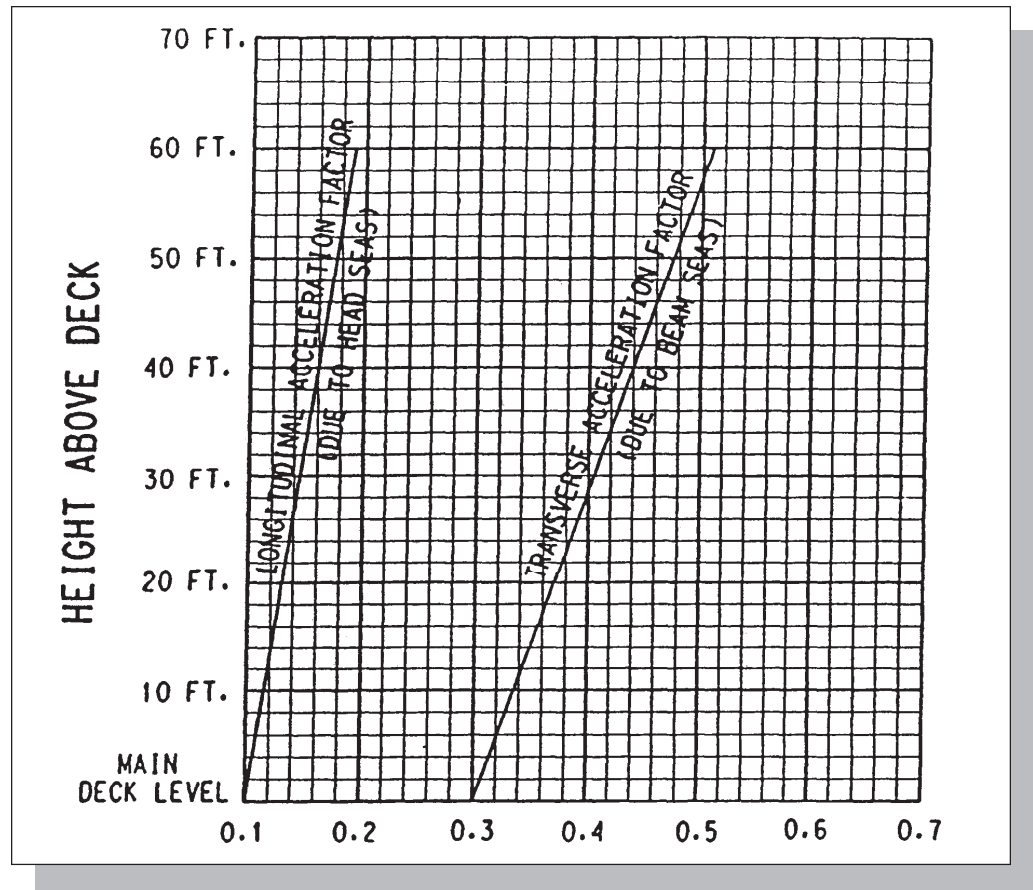

Figure 8.16-1 Design Horizontal Acceleration Factor (from Venezuela to Punto Fijo)

8.17 ROLL-ON AND ROLL-OFF OPERATION

Roll-on and roll-off operation considerations include:

- Dock (sheet piling) structural load-supporting capacity
- Tide levels for roll-on or roll-off for a floating barge
- Ballast requirement
- Ramps, spanning bridge and its slope change because of load movement
- Water depth sufficient that the barge will not be grounded
- Water elevation data
- Barge deck and framing to support roll-on and roll-off loads



Figure 8.17-1



Figure 8.17-2

9

RIGGING PLANS AND DIAGRAMS

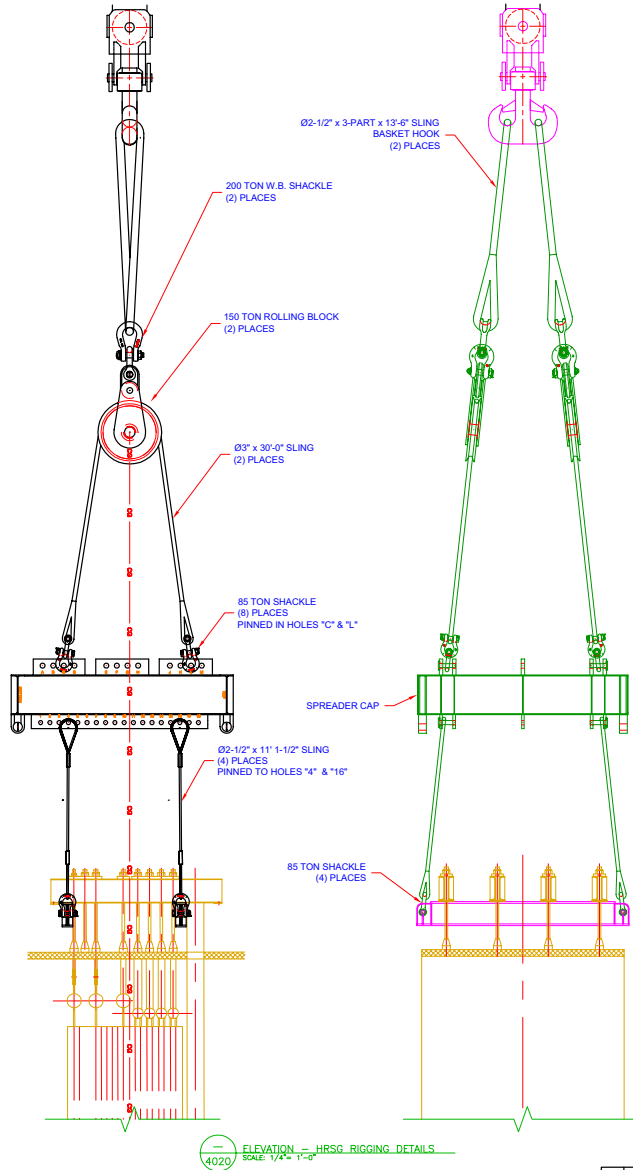

4	05MAR02	ADDED OBSTRUCTION TO SSL	MJB	05MAR02		
3	18FEB02	CHANGED RIGGING SETUP & CRANE LOCATION	MJB	18FEB02		
2	28JAN02	CHANGED CRANE LOCATION	MJB	28JAN02		
1	02JAN02	ADDED PIPE TO SITE PLAN	MJB	31DEC01		
0	17DEC01	ISSUED FOR REVIEW	MJB	17DEC01		
Rev.	Date	DESCRIPTION	Date	Date	Date	Date

The data and information contained in this document are the exclusive property of Bechtel Equipment Operations, Inc. and may be the subject of United States and foreign patents or applications. Reproduction, copying, disclosure or the use of this document, data and information without the written permission of Bechtel Equipment Operations, Inc. is prohibited.

Bechtel Equipment Operations, Inc.
 Rigging Department, Louisville, KY
 PICK & SET HRSG MODULE 4020
 REDBUD POWER PROJECT
 BECHTEL POWER / BECON
 LUTHER, OK

Scale: 1"=30'-0" U.S. Job Number: 24600 Drawing Number: 4020 Sht 3 of 3 Rev: 4

9. Rigging Plans

9.1 INTRODUCTION

Much of Bechtel's work includes heavy lifting (HL) and/or heavy hauling (HH). Skilled planning of these activities is vital to the safety and success of a project.

These activities are, by their nature, potentially high risk. To minimize this risk, it is essential that a competent person properly plan every HL and HH operation. In the Bechtel organization, the center of excellence for HL/HH activities is the Bechtel Equipment Operations (BEO) rigging department. It provides the competent persons.

The degree of planning involved will vary according to the complexity of the task. Typically, a rigging plan for a complex operation will need to include the following:

- An assessment of the risks involved in the particular operation
- A method statement to ensure that a system of work is in place to make sure that HL/HH operations are carried out safely
- Drawings fully illustrating the engineers' intent and relaying it in sufficient detail to those who conduct the work
- Special procedures in the form of written instructions
- Checks to be adopted
- Reference data, manufacturers' assembly instructions, capacity charts, and calculations

9.2 PURPOSES OF STUDIES

A rigging plan for a project commences with a study, a critical part of which is a drawing.

There are two main reasons for the preparation of any drawing:

- Investigate
- Inform

Investigative drawings are intended to investigate the practicality of a concept or the implications of a proposal and check details and interfaces. Together with calculations and

technical data such as capacity charts, drawings allow the engineers to arrive at an informed conclusion. They are primarily working tools; they may demonstrate the impracticality of an idea and may never be issued. Selected investigative drawings will be worked up to the *inform* level.

Informative drawings are, as their name suggests, intended to inform and will be formally issued. They need to contain a minimum of information required to relay the engineers' intent to the targeted audience. The appearance and content of informative drawings need to be standardized as outlined in this section.

9.3 PRELIMINARY STUDIES

9.3.1 Timing

HL/HH haul considerations are vital to the execution strategy for major projects. Heavy and large items can have extremely long lead times in design and fabrication. Handling practicalities and cost are major considerations when envelope sizes and weights of critical items are specified. Obtaining the input of the HL/HH engineer and determining the HL/HH means at an early stage are critical to the execution strategy where abnormal items are concerned.

The equipment to handle extreme "abnormals" is not readily available and needs to be booked well in advance. Adequate time to plan and to mobilize is essential if the cost is to be minimized. (Short notice mobilization can be very expensive.)

The HL/HH investigation phase must be conducted in the initial project planning phase, well before full field mobilization.

9.3.2 Aims of Preliminary Studies

During the investigation phase, possible methods and equipment that could be used are investigated, and one or more solutions are recommended for adoption and development.

The aim of this phase is an overall scheme for the works to provide:

- A safe solution with risk minimized
- A method compliant with project requirements
- An efficient and cost-effective solution
- An optimized schedule with minimized jobhours expended

Advice as to how the requirements may be adjusted to aid greater efficiency and yield cost savings may also result. Noncompliant options may be offered.

9.3.3 Scope of HL/HH Activities

The scope of the activities involved will be determined in the inquiry and/or by negotiation and may include:

- Offloading from a barge, ship, or rail car
- Hauling to the site by public roads and/or site roads
- Offloading and temporary storage
- Reloading and transport to the lift or placing location
- Lifting activities (cranes, mast systems, gantries, gin poles, and strand jacks)
- Tailing
- Skidding and rolling
- Specialized transport
- Jacking works (jack and pack, climbing jacks, use of trailers, and cylinder jacking)

Associated activities not specifically covered under the remit of HL/HH but which would be handled using similar principles include:

- Barging
- Shipping
- Sea-fastening
- Load-in and load-out works
- Use of floating cranes
- Weighing

9.3.4 Drafting of the Technical Specification

At some stage in the life of the project, a technical specification for HL/HH activities must be defined. This project function is one in which BEO, as a center of excellence in HL/HH services, is mandated to assist where required. If no specification is forthcoming, the BEO may need to draft its understanding of the specification before any contract is accepted.

The aim of the technical specification is to provide information to sufficiently inform a bidder of a project's technical requirements, to disseminate critical information, to generally describe and inform, to provide a level basis for all bidders, and to eliminate ambiguity and minimize clarifications.

Typically, the technical specification:

- Defines plant location and local conditions
- Describes site road and rail links, quay and port locations, and restrictions and limitations

- Includes a site plan or plot plan
- Includes a specification of lifts, weights, sizes, center of gravity (vertical versus horizontal), etc.
- Defines the construction philosophy, and includes a draft (milestone) schedule
- Defines the extent of the working area, construction holds, no-go areas, services, and other restrictions
- Defines ground bearing pressure (GBP) and other permissible loadings
- Defines any operational restrictions (live plant, extreme weather, and remote location)
- Defines hand-over location by item (commencement of work)
- Defines conclusion of work (e.g., lifted on prepared foundation versus lifted, shimmed, aligned, leveled, bolted, or grouted)

The technical specification will not define everything that the engineer will need to conduct the work.

9.3.5 Information Gathering

9.3.5.1 Sources of Information

After the scope of the work and the aim of the outcome are determined, all of the information required to conduct the study and prepare the preliminary plan must be obtained.

Development of an economical and efficient rigging plan requires obtaining as much information as possible early in the project.

Establishing an economical and efficient method will require information about the site, vendor equipment, and available lifting equipment. In the early days, information is typically sparse and a complete technical specification is unlikely at the stage of producing preliminary plans. This situation should improve as the project progresses. Before final plans are prepared or contracts are signed, a technical specification needs to be received from project team members or developed with them so that no ambiguity develops. (See preceding section.)

You will need to seek out the balance of the information as best as you can. Limited information such as general arrangement drawings, plot plans, and equipment specifications may be available through the project. The best way to obtain and extract information is to ask key project people, call vendors, or meet with the vendors' representatives. Later, more detailed vendor drawings and project steel and concrete drawings will be available with which to refine the rigging plan. A site visit may be required. Note that in a contractual situation, you will not be able to rely on any information gathered informally or from third parties. All critical information must be confirmed to you formally and should form part of any ensuing contract. For example, do not rely on hearsay for a weight where lift capacities are critical; do not accept

“we have had cranes as big as that on there without mats before”; properly check out the ground bearing. Always err on the side of caution in direct inverse proportion to the quality of the information, particularly where a decision is critical. Poor information equals low safety factors.

The following subsections describe some of the key points to consider during all stages of lift planning and development.

9.3.5.2 Vendor’s Equipment Drawing

A vendor’s drawing shows the general arrangement of the item to be lifted, including any attached platforms, protruding pipes, and lifting lug locations.

The vendor’s vessel drawing should indicate the shipping weight, erection weight, and center-of-gravity location. These data should be determined accurately and verified from sources such as the fabricators’ drawings, checked computations, similar units previously handled, Bechtel Engineering Standards, and shipping weights. Whenever possible, obtain the scale weights before a unit arrives at the site. Check that the weight shown is the weight to be handled. Ask:

- Is insulation included?
- Are platforms and ladders fitted or not?
- Are containers empty or full? (Does the transformer weight include oil or not?)
- Does the shipping weight include saddles and supports?
- Is there any material hang-up inside?
- Are trays and packing fitted in exchangers?
- Has any equipment been added to an item since the drawing was made?

Beware of dismantling anything for several reasons. The information tends to be poor. Once you have the weight, you often cannot get rid of it again if it weighs too much. It will invariably weigh a lot more than you were told. You do not really know where the center of gravity is. Often, locked-in forces are free to act when the final fixing is released; you cannot always predict their magnitude or direction. Demolition does not attract the same importance as assembly and tends (wrongly) to be a less safe activity as a result. There is never the same money in taking something apart, whereas the work is, if anything, more exacting; thus, there is the tendency to minimize the cost and run capacities to the limit. Exercise extreme caution and use high safety factors.

Two inexpensive ways of verifying lift weights of vendor-supplied components are (1) to have the vendor call with the weight of the component that the shop crane indicates or (2) to check the truckers’ scale weight. Regardless of the method used, lift weights should be verified before the lift. If the load is irregular, contact the vendor for recommendations on how to level the load during the lift. Be clear as to who is responsible for obtaining an accurate weight.

Regardless of any methods to determine the weight, the responsibility should in most cases lie with the entity you are working for. If it weighs too much, you can be sure that it will be your responsibility if you do not clarify this point.

The vendor's drawing will also show the purpose, location, and orientation of approved lifting lugs or lifting points. Often, the vendor will supply a sketch of the intended lift method, including sling locations and orientations. If the drawing appears ambiguous or if the lift planner identifies a better way of rigging the vessel, check back with the vendor for approval or clarification. Beware that lugs attached to a piece of equipment may be there for purposes other than lifting the entire vessel. Sometimes shop fabrication lugs will remain on the vessel after it leaves the shop. These lugs may be smaller than the approved erection lugs and will not be sufficient to lift the entire vessel. Never apply a greater load to a lift point than it was designed for or load it in a different direction than designed for. Although checking the adequacy of an item (and its lifting attachments) to withstand the loads imposed during lifting should not normally be part of BEO's remit, conduct some simple proving checks anyway as early as possible for your own peace of mind. It is not unknown for the load to fail during lifting.

In addition, check the physical size for the shackles and slings to be used. At times, a trainee may be assigned to this job and a lug that fits no known shackle may result. It can be changed if you identify the problem early enough.

If lugs are required but not provided, check with the vendor or a design engineer. Welding limitations or back-up stiffeners may be required such as with a thin-walled stack section.

9.3.5.3 Project Site Date

An overall site plan is necessary to plan equipment haul routes onto the site, to identify offloading and temporary storage areas, and to plan onsite hauling routes from the storage area to the lift location. Detailed plot plans are required to identify foundation locations and to select the optimum positions for the lift crane.

Ideally, where the schedule permits, the largest and heaviest items will be lifted and/or placed directly on arrival, eliminating temporary storage for these items. If this is not possible for schedule reasons or where dressing is involved, storage and dressing are ideally at the foundation, allowing direct lifting and placing at a later date.

9.3.5.4 Location of Utilities and Terrain Conditions

Underground utilities such as water and sewer lines, conduit banks, power and instrument cabling, ducts, and culverts must be located and avoided as far as possible when cranes or heavy loads are located or moved. Where this is not possible, the design engineer must structurally evaluate their capacity. Temporary bridging or layers of crane mats may be required to reduce stress levels.

Working space requirements for the assembly and operation of equipment must also be considered. For example, in addition to locating a crane, the space required to erect it and lay

down its boom must be considered. This is usually not much of a problem for telescopic boom cranes, but for lattice boom truck and crawler cranes, ample room must be provided to lay out and assemble the full length of the boom on the ground. Once the boom is assembled and raised, the crane will have limited mobility, especially cranes with long boom lengths. The terrain that the crane must traverse from its assembly area to the lift location must also be considered. It must always be possible to render a crane safe in the event of high winds. Where the operating location of a crane prevents completely laying down its boom within a very short time, alternative plans must be made to support and secure the boom to make it safe.

9.3.5.5 Other Data

In addition to the overall site data, detailed project drawings for the building or unit are required. A plan of the building or unit in which the vessel or equipment must be set is necessary to determine lift height, pick and set radius, boom clearance, distance, and tail swing clearances.

9.3.6 Data Requirement Sheets

The following sheets are a “shopping list” of the technical information that you may require. Use them as applicable as a checklist. Add where necessary.

Item List

Description	Comments
Names of items	
Reference number	
Plant location	
Horizontal or vertical	
Dressed (Y/N)	
Envelope dimensions	
Receipt at?	
Manner of receipt (FAS/FOT, etc.)	
Delivery date	

Item Details (per Item)

Description	Comments
Item name/reference number	
Outline drawing	
Detail drawing with full dimensions	
Erection weight	Confirm before lifting
Center of gravity location	Confirm if possible
Lift attachment type and location	
Lift attachment detail	Check suitability of design and shackle fit

Base ring/support saddle detail	
Extent of dressing	
Platform drawings	
Receipt on Barge/Ship	
Description	Comments
Quay layout	
Access and egress onto quay area	
Cross-section through quay/profile	
Quay height relative to datum	Only if ro-ro envisaged
Mean water height relative to datum	Only if ro-ro envisaged
Tidal range	Only if ro-ro envisaged
Tide tables	Only if ro-ro envisaged
Date of loading/load-out	Only if ro-ro envisaged
Location of piles/ground beams	
Loading on piled locations	
Loading generally on quay	
Crane rails on quay and loading	
Dredging plan	
Maximum size of barge/ship accommodated	
Maximum draft	
Mooring bollards location and load	
Craneage available	
Responsible port authority	
Physical restrictions	
Electric cables/voltage	
Charges for use	Is BEO responsible?
Barge/ship details, including cross-section	
Loading arrangement	
Unloading location on quayside	
Can ship/barge be turned?	
Receipt at Storage Area	
Description	Comments
Location and layout	
Route in and out	
Intended location and orientation within area	
Strong points	
General permissible loading	

Available craneage	
Available labor	
Support arrangement	
Support height	If not on ground
Clearance width between supports	If at height

Receipt on Trailer

Description	Comments
Trailer type and configuration	
Trailer width and length	
Tractive arrangement, including drawbar	
Saddle numbers and locations	
Saddle drawings	
Orientation on trailer (plan and rotation)	
Transport height and width	
Transport drawing	
Lashing arrangements	
Handover location and orientation	
Jacking points if any	

Receipt on Rail Car

Description	Comments
Layout of rail spur	
Intended unloading location	
Operational restrictions imposed	
Permits required	
Craneage available	
Access from road	
General ground loading capacity	
Undergrounds	
Overheads	
Rail car detail	
Orientation on rail car (plan and rotation)	

Route Survey

Description	Comments
Intended route to site	
Public roads and/or private roads	
Map of route	
Envelope dimensions of load/transport	

Transport equipment turn characteristics
Swept area, tightest turn
Critical turns (measure/sketch their profile)
Height restrictions, cables, and location/type
Width restrictions, signs, etc.
Street furniture to be removed
Ramping required
Culverts, drains, and other undergrounds
Bridges, their design, and their carrying capacity
Permit requirements and responsible authorities
Time to obtain permits
Statutory height/width/weight/axle load limits
Alternative routings
Photograph of route

Site

Description	Comments
Site layout	
"North" location	
Plot plan with item locations	
Foundation details	
Installation elevations	
Intended "holds"	
Services locations	
Permissible GBP	
Structure details	
Any piled crane foundations?	
Routes on site	
Permit system	
Working hours	

Site Storage Area

Description	Comments
Location and layout	
Route in and out	
Intended location and orientation within area	
Strong points	
General permissible loading	
Available craneage	
Available labor	

9.3.7 Equipment and Method Selection

Having gathered all the necessary information and fully understanding what the job entails, the rigging engineer will investigate solutions and proceed to equipment and method selection.

9.3.7.1 Considerations

In doing so (together with colleagues), in addition to the technical aspects, the rigging engineer will need to consider the following as they apply:

- **Country**
 - Bechtel policy about the country
 - Existing alliances and affiliations
 - Completion
- **Site**
 - Site visit/offsite route survey
 - Ground conditions at site
 - Prevailing weather conditions
 - Quays and jetties that may be used
 - Laydown areas
 - Potential crane locations
 - Onsite routing
 - What the site and project personnel actually want (attempt to understand their preferences, prejudices, and requirements)
- **Equipment**
 - Equipment to be made available free issue (or could be by negotiation)
 - BEO equipment in locality
 - Equipment available locally
 - Local suppliers and their existing alliances, experience, and expertise
 - Costs of equipment of interest
 - Locally prevailing rates for equipment that BEO is to supply
- **Mobilization**
 - Possible routes for transport of equipment to site and limitations
 - Budget pricing for mobilization

- Tax situation, particularly as regards to temporary import
- Restrictions on age of equipment
- Local laws on equipment, certification requirements, testing, etc.
- **Labor**
 - Scope of supply as regards labor
 - Availability of local labor
 - Rates of pay and benefits to be paid, holiday, and severance
 - Workers compensation and insurances
 - Agency rates
 - Labor employment laws
 - Accommodation type available and cost and related services
 - Laws on ex-patriates, visas, and the like
 - Ex-patriates' tax situation
 - Site working pattern (rotations, etc.)
 - Personnel transport type and cost
 - Air fare cost

These factors will often determine the practicality of one technical solution over another. Specifying a crane that cannot get to the site, using a high-intensity labor method in a high labor cost country, preparing a study where Bechtel does not want to work, and so on are not practical methods.

9.3.7.2 Brainstorming

Armed with full knowledge of what the job entails, country and site conditions, and equipment availability and cost, the rigging engineer needs to:

- Examine the critical items and together with engineering colleagues:
 - Consider conventional BEO possibilities (may be several)
 - Consider innovative solutions
 - Consider possible alliance partner solutions
 - Consider local solutions
 - Investigate competitors' options
- Examine the lesser items:
 - Determine the minimum equipment required for the lesser items
 - For lifting, investigate the numbers of crane locations and re-rigs required
 - Try to balance greater capacity versus speed and cost
- Look at the support equipment:
 - Determine what general support equipment is required

9.3.7.3 Selection of Lifting Means

After the site data and vessel information are known, crane or other lifting equipment selection may begin.

- Identify all the lifts to be investigated on the plot plan(s). If there are several and they are consecutive with the crane being relocated between them, consider joining all the plot plans together to obtain an overall picture of the site and where the items are on it.
- Identify the critical lifts driving the crane selection on the plot plan(s)
- Identify the underground services
- Identify the laydown areas and transport routes
- Identify no-go areas and live plant
- Locate any specially provided access and hard standing provided for cranes
- Make an initial assessment. Knowing the size and weight of the critical lifts, determine an approximate boom length and radius, and form an early assessment of the likely capacity of the crane required. Use the crane manufacturers' capacity charts as a reference. Information about lifting equipment is available through many sources, including the Bechtel Equipment Catalog, equipment manufacturer, or crane rental contractor.

- Decide the type of crane. Decide whether a crawler, ringer, or mobile is likely to be the best option, and try to identify a suitable type (or types) from the list of machines economically available for that project.
- Identify possible crane locations. Try to identify suitably clear areas in which to locate the cranes and lifting equipment
- Check out possible main lift crane(s):
 - These days, the assessment of the crane(s) best suited is mainly done by simulating the worst case(s) in AutoCAD using prepared blocks for the items and for the cranes (to the same scale as the plot, normally full size). By this means, the boom length actually required can be checked. A generous allowance for the rigging and hookblock must be allowed. The base ring and support saddles must clear the foundation by at least 600 mm (2 feet). Do not forget that slings do stretch some. In addition, when upending, do not forget that some tailing methods (J-skids and trailer tailing for example) may result in the tail being a considerable height in the air when vertical (often higher than the foundation).
 - Test your initial thoughts. Locate the crane in the area that you selected and orient it to the best advantage considering the surroundings and foundations and undergrounds; adjust it within available limits to obtain the best compromise of boom length and radius/capacity, while maintaining adequate clearance for the item to be lifted and the surroundings. You will often find that adding boom has little detrimental effect on capacity, whereas increasing radius quickly does. If this does not work, try a different machine.
 - If you do not have AutoCAD available, revert to tried and tested methods. Prepare a transparent overlay showing the selected crane in the plan and a second overlay showing the item. Both will be to the same scale as the plot. With these templates overlaid on the plot plan, determine where to best spot the crane(s) so that there will be the least amount of interference.
 - Having determined a likely radius in the plan, examine the elevation by similar means (using template overlays), and check clearances between the boom and the vessel and between the vessel and surrounding obstructions. Check capacity.
 - Whichever method is used, maintain clearances between the boom and the vessel and between the vessel and surrounding obstructions during all phases of the lift, including swinging, hoisting, and

- booming. Minimum clearances should be indicated on the lift layout drawings. Similarly, clearances between the tail swing of the crane and any backmast and capacity-enhancing devices (Superlift, etc.) must be shown for all phases of the lift.
- When examining cranes, try as far as possible to use common lift positions, do as much as possible from one location, and try to avoid changing the boom length too frequently.
 - Consider alternative means:
 - When available, properly sized cranes usually provide the most economical lifting methods. There are a number of cases where this may not be so:
 - * The project is in a remote location.
 - * Labor is cheap.
 - * Cranes are not available.
 - * There is a long time between heavy lifts.
 - * Something needs to be held at a height for a prolonged period.
 - * The weight is extreme.
 - * Lifts will occur inside buildings.
 - * Space is too restricted to place a crane, and the design engineer cannot reposition other equipment or hold equipment foundations to provide adequate room.
 - * The lift height is small.
 - * The obvious solution requires moving in straight lines with a suspended load.
 - * This is only one very heavy lift among a number of lighter items.
 - * Only the hoisting means is required, e.g., lowering down a shaft or lifting within a load-carrying structure.
 - In such cases, restrict the use of cranes to lesser lifts/support duties, and consider the following alternatives for the critical lifts:
 - **Portable hydraulic telescoping gantries**—These gantries are ideal for offloading equipment and work well for setting equipment on low pedestals. They can lift and carry, are set up very rapidly, are compact, and are easy to transport. The cost of such systems is low

for their capacity. They do not require heavy support craneage to erect. However, the lift height is restricted and there is more labor content in building and transferring the rig. Movement of the rigs is conventionally unidirectional although the suspension can include cross-slide facilities. Where required, they can be used on elevated runways and the rigging can incorporate strand jacks or the like for greater hoisting range. Accessories such as turntables are available.

- **Strand jacks**—Strand jacks are hoisting devices. Each jack unit consists of two grip heads between which is fitted a double-acting hydraulic cylinder with hollow ram. A tendon, which is a bundle of approximately 3/4 inch wire strands, passes through the hollow body of the jack and the two grip heads. Each strand is gripped individually by collets seated in the upper and lower grip heads. As the jack is extended, the upper collets grip the strands, and the tendon is raised through the lower head. As the jack retracts, the lower grip head locks the tendon, and the upper head releases. In this manner, the tendon is pulled through the jack in a series of strokes. The lower end of the tendon terminates in a lug that is attached to the load. A range of capacities is available up to about 900Te/unit. Multiple units are normally used under central computer control.

A strand jack can be used horizontally as a heavy-duty linear winch for pulling a structure such as an offshore jacket along slide-ways for example.

Conventionally, they are mounted on a load-carrying structure to raise or lower a load. Typical Bechtel uses include very heavy vessels or HRSGs.

- **Mast systems**—Mast systems typically are sectional lattice masts erected in pairs to the required height. They are spanned by a header beam on which is mounted the hoisting means. Strand jacks may be used for this; alternatives such as wire rope hoists or chain-link jacks (performing a similar function) exist. Masts of this type are load-carrying. There are systems working a climbing jack principle where the beam starts at low level and is raised by jacks either climbing the mast or pushing up from the base. In these cases, the mast is used to stabilize the jacking system and is lighter. In all cases, x-slide facilities and swivels can be fitted. Conventional rigging is used from the swivel hook. PSC masts use strand jacks and can be arranged to luff.

These systems largely replaced gin poles and are themselves being supplanted by the heaviest of cranes. However, they still have their place in specialized

applications. Their main disadvantages are the time to erect, jobhours involved, support craneage required, need to guy (in most cases), foundations required, deadmen for the guys, and relatively slow lifting speed. Their advantages are high capacity and low capital cost for their capacity. They can be used in confined spaces and can hold loads for prolonged periods; their capacity depends less on height than a crane, and they can typically go to approximately 120 m. They are useful for mid-range lifts (approximately 400Te) in remote regions.

- **Gin poles**—Gin poles are the precursor of the modern mast systems. They are sectional lattice masts erected in pairs to the required height and mounted on articulating bases. They use a header beam (mounted on articulating bearings). They use winches located at ground level as the hoisting means, with the lead lines led up the poles to sheave blocks suspended from the header beam. Gin poles are not used much now but are still favored in Japan. They do the job adequately and are relatively inexpensive. They have lesser capacity than modern mast systems generally and are slow to set up. They suffer all the other disadvantages. In some cases, they can be arranged to luff.
 - **Portable overhead gantries**—A number of companies have proprietary portable (rail-mounted) overhead gantries. These gantries use winches or alternative hoisting means and work well for setting equipment on high pedestals (35 to 110 feet).
 - **Other alternatives**—It may be possible in some cases to drive an item directly to its foundation; horizontal drums, slug catchers, and heavy pre-assembled units (PAUs) are candidates. The trailers can often be used to jack the piece up or down; alternatively, external jack and pack methods can be used where suitable jacking points exist.
- Consider delivery to the lift location:
 - Look at where the item to be lifted is to be lifted from, where will it be made available, or where can it be brought to. Trace the vessel's route over the plot plan and determine the best movements and location for the transporter, vessel, and crane(s). Determine how much space the delivery method will use; determine whether it will interfere with the lifting method. Can you keep to the roads or is it necessary to go onto the plot; is it necessary to drive over foundations; are any holds required?

- Consider tailing by crane:
 - When a piece needs to be upended, the tailing means need to be considered. In the vast majority of cases, using a crane is the obvious solution. Often a suitably rated crane will be on site for general site use and for placing smaller items.
 - Knowing the weight and location of the center of gravity, calculate the tail load. Preferably, do a spreadsheet run showing the load decay by angle of inclination. You can sometimes take advantage of this information to specify a lesser capacity crane.
 - Where possible, try to locate the main lift crane, the load, and the tail crane so that you can get the required movement of tail to head (or vice versa) without needing to move the tail crane. This approach might allow the use of a telescopic crane and may simplify setup and ground preparation. It is quicker and may be cheaper.
 - Ways to achieve this approach include:
 - * Locating the main lift crane to the side of the head of the item and slewing the head toward the tail crane using the main lift crane as the lift progresses. The tail crane basically holds the tail in a fixed location until the last few moments.
 - * Locating the tail crane to the side of the tail and slewing the tail toward the head as the lift progresses
 - * Booming out the tail crane as the tail load decays in line with the reducing capacity of the tail crane
 - * Booming out the main lift crane toward the tail crane within its capacity
 - * Combinations of all the above
- If the piece you are upending is long and you cannot get all the movement that you need from cranes in fixed locations, reduce the distance head to tail by some other means. The simplest way is to use a crawler crane at the tail; pick the tail and crawl to the head as the lift progresses, finally booming out as the load decays. It is possible, but not as preferable, to keep the tail fixed and crawl the head to the tail. Alternatively, you could consider one of the alternative methods such as J-skids or trailer tailing as described later.
- When designing a tailing arrangement, avoid side loading crane booms and/or avoid the load swinging into the boom when picked. This situation can happen if the suspension is not truly vertical above the lift points at the time when the item is lifted clear. The load

ideally needs to find its own position when picked without increasing or reducing lift radius (particularly on the tail crane). One way to achieve this approach is to have the tail crane alongside the tail at pick (rather than behind the tail) and to have the tail crane on free slew. Any movement along the length of the vessel will cause the tail crane to slew at the same radius, thus maintaining vertical suspension.

- Keeping the tail load over the side of a crawler crane is preferable to being over the corner or the front because the loads will be spread well along the length of one track, rather than being concentrated on the front pads. The tail can be brought in front of the crane toward the end of the operation to take advantage of the distance gained while slewing and to reduce the distance to be crawled (thus requiring preparation).
- Finally, keeping the crane to the side allows transport to be easily removed to the rear.
- Where cranes are not the answer for tailing, consider alternative tailing means:
 - **Hinged tail frames**—It is possible to provide a two-part hinge arrangement to support the tail, one part bolted to the base ring of the vessel and the other mounted on skids or trailers. The hinge point needs to be on the centerline of the vessel (or above) to avoid the load moving to over-center as it approaches the vertical. This point, of course, ends up being quite high, which may require longer crane booms and consequent loss of crane capacity. To minimize this situation, most designs incorporate two hinge points: one on which the tailing commences and a second that engages as the load approaches the vertical. This load transfer needs to be accommodated in the trailers or whatever else is used to support the frame. There are a number of proprietary designs, most of which are adjustable to cover a range of vessel sizes and weights.
 - **J-skids**—A J-shaped skid can be bolted to the base ring of a vessel. As upending progresses, the skid rolls on the profile of the J, constantly altering the point of contact and minimizing the support height. The profile of the J needs to be such that the center of gravity of the load being lifted never crosses the line of support of the tail. This profile would lead to the load moving to “over-center” and becoming unstable as it approaches the vertical. The J-skid needs to be mounted on skid rails/rollers or trailers, allowing it to be moved toward the main lift during upending. The skid needs to engage in the component on which it rolls, which is sometimes achieved by a type of rack arrangement of spigots and holes. Because the point of support is changing throughout the tailing while the tail load is also changing, the loading regime on whatever is supporting the skid is also changing, and its design needs to

reflect this change. If trailers are used, they will need to have the required capacity at all phases and to be adjusted through the movement.

- **Trailers**—Trailers can be a very convenient method of supporting a tailing frame. In most cases, heavy trailers are used to deliver the piece to the lift point, and then they can be used to support the tail during lifting. This approach is best if transport and lifting are within the brief of the same company. Probably, the trailers will require no more room than was used when they delivered the vessel, the ground preparation is the same, and the pressures relatively low. Self-propelled multi-axle trailers (SPMTs) are ideal for this approach because they can drive themselves in. The only adjustment that may be required is where the tail height for fitment of the frame is higher than that when it was delivered. Often, it needs to be lifted slightly. This lift can usually be achieved with the trailer hydraulics. On the face of it, the trailer will need to be sufficient to carry the tail load at pick. The line of application will not generally be central on the trailer and will change as the lift progresses; this change needs to be accounted for. Furthermore, a school of thought says that the trailer should be capable of taking the entire load. This theory is on the basis that there is a theoretical risk of the piece effectively balancing on the trailer on its hinge when vertical, with the crane doing nothing more than stabilizing it. In practice, there is usually so much spring in the system as to require the crane to be actually lowered off (with the piece vertical) to create this condition. Most designs use a cup arrangement for the hinge (rather than a pin); this arrangement allows the frame to be lifted clear as a direct continuation of the upending, avoiding this possibility.
- **Skid systems**—It is also possible to mount the tail frame on rails, supported through skid shoes using Teflon or the like. Alternatively, it may be mounted on Hilman rollers or similar. The tail will need to be winched in as the lift progresses. The rails need to be mounted on crane mats or other foundations and well leveled and aligned. The accuracy this approach requires, the complexity, potential hang ups at the rail joints and the need to transfer the tail weight onto this arrangement in the first place are significant disadvantages. It is relatively low cost and can work well when upending steam generators inside reactor buildings for example when the rails are mounted on concrete.

- Consider less critical lifts:

- Now consider the lesser lifts. Determine whether they can be sensibly made with the same crane as used for the critical lifts from the same positions. Determine whether it makes better sense to do the critical lifts and demobilize the largest crane thereafter. Determine whether the crane used for tailing the critical lifts should be used as the main lift crane for the less critical lifts (supplemented with a lesser crane). Determine whether masts will be used for the critical lifts; if so, determine whether the crane needed to build the system will be enough for the lesser lifts.
- Plan your strategy:
 - Having determined the most appropriate equipment to conduct the critical lifts and the lesser lifts, where to locate the equipment, how to make the lifts, and how to conduct the tailing, you should be in a position to rationalize your strategy. Define your thinking, and seek consensus to proceed to complete preliminary for one or more ideas.

9.3.8 General Considerations in Preliminary HL/HH Plans

In preparation of preliminary HH/HL plans, general considerations will include the size and weight of the pieces to be handled, the site and route conditions, the equipment available, possible multiple uses for the equipment, schedule impacts, and costs.

The plans will:

- Determine the possible handling means, i.e.:
 - Cranes (type and location)
 - Mast systems
 - Gantries
 - Trailers (type, numbers, etc.)
- Determine their impact on the pieces to be handled:

- Loads imposed at differing phases
- Possible interferences during handling
- Lift lug criteria
- Lashing and securing locations and loads
- Extent of dressing possible
- Omissions required
- Maximum weight possible
- Maximum size envelopes
- Stability of the load
- Stresses imposed
- Determine the impact on the surroundings:
 - Equipment locations
 - Swing radii
 - Working areas required
 - Sterilization and holds required
 - Clearances to obstructions
 - Loads and pressures imposed
 - Civil works required
 - Build position– Boom laydown direction (in operating location)
 - Effects on undergrounds utilities
 - Transport routes and modifications required
 - Permit requirements
 - Wind restrictions
- Determine the logistics schedule impacts, for example in lifting:
 - Crane locations required
 - How much can be done from each location
 - The route between crane locations
 - Holds required on plant and racks

The preliminary plans will consist of basic lift and haul studies supported by calculations and other data where required. Site investigations and route studies may be needed. Investigation with equipment suppliers and supporting data from them may be required.

9.3.9 Outcome

The outcome of the investigation phase should be:

- A recommended strategy
- Identification of type of equipment required
- Input to work up a preliminary schedule with a planner, leading to:
 - Durations of equipment required
 - With commercial personnel, draft costings
 - Clear direction about the impact of these activities on the surroundings
 - Clarified interfaces with others (what do we expect from them)
- Preliminary plan for the works in sufficient detail to explain the intent clearly to others and to identify the concerns and interfaces (See later sections for required level of detail.)
- Draft method statement where required to further explain the intent

9.3.10 Constructability Studies and Pre-Engineering

Constructability studies where HL/HH activities are involved are an example of preliminary (investigative) work where BEO involvement, on behalf of a project, is mandated. This work would typically occur at the project FEED stage, and BEO would be expected to advise the project on:

- Prior experience in similar cases and lessons learned
- Design of items to obtain best balance of progress versus construction equipment cost
- Latest developments in HL/HH technology
- Innovative concepts for HL/HH services
- Local availability of construction equipment
- Plant layout to minimize equipment requirements
- Scheduling to obtain maximum effective use of lift and haul equipment
- Maximizing lifts within information on the capacity of equipment readily available
- Cost of alternatives

9.3.11 Development

Selected preliminary studies will be expanded, refined, and changed as the job progresses and will eventually evolve into a fully detailed operational plan.

9.4 DEVELOPED STUDIES

9.4.1 Categories of Drawings

After the investigative phase has concluded and the way forward has been established, HL/HH rigging studies need to be prepared to sufficiently inform others (internally and externally). These studies are to be prepared to a level of detail appropriate to the purpose to which the study is to be put. Thus, it is very important to identify the purpose and the target recipients.

To assist in this effort, BEO has defined three categories of drawings (by purpose) and has tabulated the minimum content required for each category. This approach is intended to ensure that every drawing contains information appropriate to its purpose; it acts as a checklist for the engineer and is a common yardstick against which internal (and externally submitted) rigging drawings can be checked.

- **Category 1**—Category 1 is typically a preliminary study intended to check the viability of a concept, identify required equipment, check loadings, define working areas, suggest equipment locations, and check clearances. Its use is primarily for early planning, budget costing, etc., within BEO and Bechtel projects. It may be of sufficient detail for some bids and is aimed at commercial as well as technical personnel. The recipients are project engineers, planners and schedulers, operational personnel, costing engineers, and managers.
- **Category 2**—Category 2 is typically a more detailed feasibility study or a first run at a working proposal. It needs to be sufficiently detailed to fully explain the intentions and highlight points of concern, interfaces, and the like. It is aimed more at technical than commercial personnel—i.e., the project's engineers and site staff and BEO's operational personnel—premobilization. One or more drawings to this level (critical items) accompany more detailed bids.
- **Category 3**—Category 3 is a working drawing, intended for construction, containing all the detail necessary for field personnel to perform the works. The drawing must relay to the workers in the field ALL of the information necessary to properly execute the planned lift in a clear, unambiguous format. Relying solely on verbal instructions to guide the rigging superintendent is not acceptable. It documents the lift and provides all the necessary analysis; it is the blueprint binding all the parties involved to a common purpose. It is an integral part of the execution plan for the works. Engineers and project operational personnel are the key target.

All pertinent instructions should be in writing or sketched on the rigging drawing. In the event that the preparer of the drawing is not present, the rigging drawing should be a stand-alone document detailing how to perform the lift.

9.4.2 Information To Be Contained on Drawings

Establish with the person requiring the drawing which category of drawing you are producing and use the table as a guideline for the information it should contain. It will be checked against these criteria.

9.4.2.1 Lifting Studies

Description	Drawing Category		
	1	2	3
<i>DRAWING UTILITIES</i>			
Job description, client, job number, drawing number, revision number, date	<input type="checkbox"/>	<input type="checkbox"/>	<input checked="" type="checkbox"/>
Site north	<input type="checkbox"/>	<input checked="" type="checkbox"/>	<input checked="" type="checkbox"/>
Plan, elevations, end views	<input type="checkbox"/>	<input checked="" type="checkbox"/>	<input checked="" type="checkbox"/>
Notes	<input type="checkbox"/>	<input checked="" type="checkbox"/>	<input checked="" type="checkbox"/>
Limiting conditions	<input type="checkbox"/>	<input checked="" type="checkbox"/>	<input checked="" type="checkbox"/>
<i>MAIN LIFT CRANE(S)</i>			
Crane manufacturer/model	<input checked="" type="checkbox"/>	<input checked="" type="checkbox"/>	<input checked="" type="checkbox"/>
Crane configuration (boom and jib lengths and type), jib and/or boom angles as appropriate	<input checked="" type="checkbox"/>	<input checked="" type="checkbox"/>	<input checked="" type="checkbox"/>
Leading dimensions of crane, tail swing radius	<input checked="" type="checkbox"/>	<input checked="" type="checkbox"/>	<input checked="" type="checkbox"/>
Machine counterweight	<input checked="" type="checkbox"/>	<input checked="" type="checkbox"/>	<input checked="" type="checkbox"/>
Crawler c/s, outrigger c/s as appropriate	<input checked="" type="checkbox"/>	<input checked="" type="checkbox"/>	<input checked="" type="checkbox"/>
Superlift to be used, back mast radius, back mast length and type, tray or carriage	<input checked="" type="checkbox"/>	<input checked="" type="checkbox"/>	<input checked="" type="checkbox"/>
Hoist block capacity	<input type="checkbox"/>	<input type="checkbox"/>	<input checked="" type="checkbox"/>
Hoist line capacity and number of parts	<input type="checkbox"/>	<input type="checkbox"/>	<input checked="" type="checkbox"/>
Two block minimum distance	<input type="checkbox"/>	<input checked="" type="checkbox"/>	<input checked="" type="checkbox"/>
Other pertinent data	<input type="checkbox"/>	<input checked="" type="checkbox"/>	<input checked="" type="checkbox"/>
<i>MAIN CRANE LOCATION AND MOVEMENTS</i>			
Erection location of crane and boom laydown direction, area required to build crane	<input type="checkbox"/>	<input type="checkbox"/>	<input checked="" type="checkbox"/>
Crane location at all phases of the operations (x and y from plant reference such as foundation)	<input checked="" type="checkbox"/>	<input checked="" type="checkbox"/>	<input checked="" type="checkbox"/>
Orientation of crane undercarriage referenced to site north	<input checked="" type="checkbox"/>	<input checked="" type="checkbox"/>	<input checked="" type="checkbox"/>
Radius (hook to centerline of rotation at all phases)	<input checked="" type="checkbox"/>	<input checked="" type="checkbox"/>	<input checked="" type="checkbox"/>
Path of load movement defined	<input checked="" type="checkbox"/>	<input checked="" type="checkbox"/>	<input checked="" type="checkbox"/>
Zone of tail swing defined and affected zone	<input type="checkbox"/>	<input checked="" type="checkbox"/>	<input checked="" type="checkbox"/>
Zone of Superlift swing defined	<input type="checkbox"/>	<input checked="" type="checkbox"/>	<input checked="" type="checkbox"/>
Foundation holds required	<input type="checkbox"/>	<input type="checkbox"/>	<input checked="" type="checkbox"/>
Extent of matting to be provided under crawler tracks or outrigger	<input type="checkbox"/>	<input type="checkbox"/>	<input checked="" type="checkbox"/>

pads defined and referenced to crane	<input type="checkbox"/>	<input checked="" type="checkbox"/>	<input checked="" type="checkbox"/>
Blocking required under ringers	<input type="checkbox"/>	<input checked="" type="checkbox"/>	<input checked="" type="checkbox"/>
Crawler/outrigger loads and distributed pressures defined at all phases of the operations	<input type="checkbox"/>	<input checked="" type="checkbox"/>	<input checked="" type="checkbox"/>
Site permissible GBP/ground preparation defined	<input type="checkbox"/>	<input checked="" type="checkbox"/>	<input checked="" type="checkbox"/>

LOAD TO BE HANDLED

Reference number/description	<input checked="" type="checkbox"/>	<input checked="" type="checkbox"/>	<input checked="" type="checkbox"/>
Reference to vendor/other drawing of item	<input type="checkbox"/>	<input type="checkbox"/>	<input checked="" type="checkbox"/>
Erection weight of load, factor added as required	<input checked="" type="checkbox"/>	<input checked="" type="checkbox"/>	<input checked="" type="checkbox"/>
Position of center of gravity	<input checked="" type="checkbox"/>	<input checked="" type="checkbox"/>	<input checked="" type="checkbox"/>
Head load and tail loads at commencement of lift (and such other phases of the lift as are critical to the crane capacities)	<input checked="" type="checkbox"/>	<input checked="" type="checkbox"/>	<input checked="" type="checkbox"/>
Location and type of lifting points	<input type="checkbox"/>	<input checked="" type="checkbox"/>	<input checked="" type="checkbox"/>
Compatibility of lugs for intended rigging	<input type="checkbox"/>	<input type="checkbox"/>	<input checked="" type="checkbox"/>
Extent of ladders, platforms, and weight	<input type="checkbox"/>	<input checked="" type="checkbox"/>	<input checked="" type="checkbox"/>
Possible interference rigging to lift items at all phases of the lift	<input type="checkbox"/>	<input checked="" type="checkbox"/>	<input checked="" type="checkbox"/>
Any temporary lift frames and the like and weight	<input type="checkbox"/>	<input checked="" type="checkbox"/>	<input checked="" type="checkbox"/>
Delivery direction where appropriate	<input type="checkbox"/>	<input checked="" type="checkbox"/>	<input checked="" type="checkbox"/>
Envelope required for transport equipment and checked for possible interference	<input type="checkbox"/>	<input type="checkbox"/>	<input checked="" type="checkbox"/>
Location of any temporary supports and loadspreading grillages and checked for interference	<input type="checkbox"/>	<input type="checkbox"/>	<input checked="" type="checkbox"/>

RIGGING

Shackle details (manufacturer, size, type, capacity, safe working load [SWL], pin size)	<input type="checkbox"/>	<input type="checkbox"/>	<input checked="" type="checkbox"/>
Sling details (type, construction, eye type, length, diameter, material grade, SWL, and factor of safety)	<input type="checkbox"/>	<input type="checkbox"/>	<input checked="" type="checkbox"/>
Spreader bar/beam (type and reference number assembly details, length and construction, capacity chart details, and SWL)	<input type="checkbox"/>	<input type="checkbox"/>	<input checked="" type="checkbox"/>
Other rigging details as required	<input type="checkbox"/>	<input type="checkbox"/>	<input checked="" type="checkbox"/>
Hook-up drawing	<input checked="" type="checkbox"/>	<input checked="" type="checkbox"/>	<input checked="" type="checkbox"/>
Item reference numbers and test certification numbers	<input type="checkbox"/>	<input type="checkbox"/>	<input checked="" type="checkbox"/>

LOAD TABLE(S)

Crane fixed weight items (hook blocks, hoist line, auxiliary blocks, and jib attachments)	<input type="checkbox"/>	<input checked="" type="checkbox"/>	<input checked="" type="checkbox"/>
Rigging weights	<input type="checkbox"/>	<input checked="" type="checkbox"/>	<input checked="" type="checkbox"/>
Load weight	<input checked="" type="checkbox"/>	<input checked="" type="checkbox"/>	<input checked="" type="checkbox"/>
Load contingency factors as applicable	<input type="checkbox"/>	<input checked="" type="checkbox"/>	<input checked="" type="checkbox"/>
Load ancillaries (ladders, platforms, contents, insulation, and fireproofing)	<input type="checkbox"/>	<input checked="" type="checkbox"/>	<input checked="" type="checkbox"/>
Special considerations that apply (dynamic effects, suction, etc.)	<input type="checkbox"/>	<input checked="" type="checkbox"/>	<input checked="" type="checkbox"/>
Total resulting lifted load	<input checked="" type="checkbox"/>	<input checked="" type="checkbox"/>	<input checked="" type="checkbox"/>
Crane capacity at all phases	<input checked="" type="checkbox"/>	<input checked="" type="checkbox"/>	<input checked="" type="checkbox"/>

Down rating factor for multiple crane lifts if applicable	<input checked="" type="checkbox"/>	<input checked="" type="checkbox"/>	<input checked="" type="checkbox"/>
Percentage capacity	<input checked="" type="checkbox"/>	<input checked="" type="checkbox"/>	<input checked="" type="checkbox"/>
Repeat load table data for all critical phases of the operation (i.e, pick, boom out, slew, place, etc.)	<input type="checkbox"/>	<input checked="" type="checkbox"/>	<input checked="" type="checkbox"/>

TAILING

Method to be used (crane/trailer/other)	<input checked="" type="checkbox"/>	<input checked="" type="checkbox"/>	<input checked="" type="checkbox"/>
Details of tailing /frame attachment if any (type, method of attachment, capacity, references, and SWL)	<input type="checkbox"/>	<input type="checkbox"/>	<input checked="" type="checkbox"/>
Crane details as main crane (as applies)	<input type="checkbox"/>	<input checked="" type="checkbox"/>	<input checked="" type="checkbox"/>
Rigging details as head (as applies)	<input type="checkbox"/>	<input checked="" type="checkbox"/>	<input checked="" type="checkbox"/>
Equipment reference numbers and certification number	<input type="checkbox"/>	<input type="checkbox"/>	<input checked="" type="checkbox"/>
Trailer details as apply, type, number of axles, location referenced to base of vessel	<input type="checkbox"/>	<input checked="" type="checkbox"/>	<input checked="" type="checkbox"/>
Tail height at commencement and completion	<input type="checkbox"/>	<input checked="" type="checkbox"/>	<input checked="" type="checkbox"/>

OPERATION DETAILS

Exclusion (working) zones	<input type="checkbox"/>	<input type="checkbox"/>	<input checked="" type="checkbox"/>
Limiting wind speeds for operation	<input type="checkbox"/>	<input type="checkbox"/>	<input checked="" type="checkbox"/>
Special operational restrictions (visibility, temperature, etc.)	<input type="checkbox"/>	<input type="checkbox"/>	<input checked="" type="checkbox"/>
Restrictions on approach to power lines, rail lines, quay edges, live plant, etc.	<input checked="" type="checkbox"/>	<input checked="" type="checkbox"/>	<input checked="" type="checkbox"/>
Restrictions on permitted slew angle	<input checked="" type="checkbox"/>	<input checked="" type="checkbox"/>	<input checked="" type="checkbox"/>
Notes of any permits to be in place before commencement	<input type="checkbox"/>	<input type="checkbox"/>	<input checked="" type="checkbox"/>
Plan showing load path, tail and superlift swing	<input checked="" type="checkbox"/>	<input checked="" type="checkbox"/>	<input checked="" type="checkbox"/>
Elevation showing minimum clearances load and rigging to crane (particularly spreader) at all phases.	<input checked="" type="checkbox"/>	<input checked="" type="checkbox"/>	<input checked="" type="checkbox"/>
Critical clearances load and rigging to surrounding plant	<input type="checkbox"/>	<input checked="" type="checkbox"/>	<input checked="" type="checkbox"/>
Path of tail and tailing crane/trailer	<input type="checkbox"/>	<input checked="" type="checkbox"/>	<input checked="" type="checkbox"/>
Elevation of load showing position at maximum height, clearance to head sheaves, and manufacturer's minimum approach (consider height of tail method)	<input checked="" type="checkbox"/>	<input checked="" type="checkbox"/>	<input checked="" type="checkbox"/>

9.4.2.2 Haul Studies

Description	Drawing Category		
	1	2	3
DRAWING UTILITIES			
Job description, client, job number, drawing number, revision number, date	<input type="checkbox"/>	<input checked="" type="checkbox"/>	<input checked="" type="checkbox"/>
Plan, elevation, and end view	<input type="checkbox"/>	<input checked="" type="checkbox"/>	<input checked="" type="checkbox"/>
PRIME MOVER			
Manufacturer/model	<input type="checkbox"/>	<input checked="" type="checkbox"/>	<input checked="" type="checkbox"/>
Horsepower	<input type="checkbox"/>	<input type="checkbox"/>	<input checked="" type="checkbox"/>
Nominal tractive effort	<input type="checkbox"/>	<input type="checkbox"/>	<input checked="" type="checkbox"/>

Axle spacing	<input checked="" type="checkbox"/>	<input checked="" type="checkbox"/>	<input checked="" type="checkbox"/>
Ballast carried	<input type="checkbox"/>	<input checked="" type="checkbox"/>	<input checked="" type="checkbox"/>
Weight	<input checked="" type="checkbox"/>	<input checked="" type="checkbox"/>	<input checked="" type="checkbox"/>
Leading dimensions	<input checked="" type="checkbox"/>	<input checked="" type="checkbox"/>	<input checked="" type="checkbox"/>
Fifth wheel height	<input checked="" type="checkbox"/>	<input checked="" type="checkbox"/>	<input checked="" type="checkbox"/>
Load carried on fifth wheel	<input checked="" type="checkbox"/>	<input checked="" type="checkbox"/>	<input checked="" type="checkbox"/>
Axle loading	<input checked="" type="checkbox"/>	<input checked="" type="checkbox"/>	<input checked="" type="checkbox"/>

TRAILER

Manufacturer and model number	<input type="checkbox"/>	<input checked="" type="checkbox"/>	<input checked="" type="checkbox"/>
Type and configuration of trailers	<input checked="" type="checkbox"/>	<input checked="" type="checkbox"/>	<input checked="" type="checkbox"/>
Leading dimensions	<input checked="" type="checkbox"/>	<input checked="" type="checkbox"/>	<input checked="" type="checkbox"/>
Axle spacing	<input type="checkbox"/>	<input checked="" type="checkbox"/>	<input checked="" type="checkbox"/>
Capacity of trailer as used	<input checked="" type="checkbox"/>	<input checked="" type="checkbox"/>	<input checked="" type="checkbox"/>
Deck height	<input checked="" type="checkbox"/>	<input checked="" type="checkbox"/>	<input checked="" type="checkbox"/>
Travel range of deck height (where applicable)	<input checked="" type="checkbox"/>	<input checked="" type="checkbox"/>	<input checked="" type="checkbox"/>
Turning circle	<input type="checkbox"/>	<input checked="" type="checkbox"/>	<input checked="" type="checkbox"/>
Drawbar length (where applicable)	<input type="checkbox"/>	<input type="checkbox"/>	<input checked="" type="checkbox"/>

LOAD DETAILS

Reference number/description	<input checked="" type="checkbox"/>	<input checked="" type="checkbox"/>	<input checked="" type="checkbox"/>
Reference to vendor/other drawing of item	<input type="checkbox"/>	<input type="checkbox"/>	<input checked="" type="checkbox"/>
Transport weight of load	<input checked="" type="checkbox"/>	<input checked="" type="checkbox"/>	<input checked="" type="checkbox"/>
Position of center of gravity	<input checked="" type="checkbox"/>	<input checked="" type="checkbox"/>	<input checked="" type="checkbox"/>
Extent of ladders, platforms, weight	<input checked="" type="checkbox"/>	<input checked="" type="checkbox"/>	<input checked="" type="checkbox"/>

LOAD ON TRAILER

Numbers and location of support saddles (where used)	<input checked="" type="checkbox"/>	<input checked="" type="checkbox"/>	<input checked="" type="checkbox"/>
Saddle dimensions	<input type="checkbox"/>	<input checked="" type="checkbox"/>	<input checked="" type="checkbox"/>
Orientation of load on trailer	<input checked="" type="checkbox"/>	<input checked="" type="checkbox"/>	<input checked="" type="checkbox"/>
Location of load on trailer	<input checked="" type="checkbox"/>	<input checked="" type="checkbox"/>	<input checked="" type="checkbox"/>
Support reactions on trailer deck	<input type="checkbox"/>	<input type="checkbox"/>	<input checked="" type="checkbox"/>
Loadspreading materials required	<input type="checkbox"/>	<input checked="" type="checkbox"/>	<input checked="" type="checkbox"/>
Lashing and securing arrangements	<input type="checkbox"/>	<input checked="" type="checkbox"/>	<input checked="" type="checkbox"/>
Required ratings of all rigging materials	<input type="checkbox"/>	<input type="checkbox"/>	<input checked="" type="checkbox"/>
Lashing points	<input type="checkbox"/>	<input checked="" type="checkbox"/>	<input checked="" type="checkbox"/>
Protective materials where required	<input type="checkbox"/>	<input type="checkbox"/>	<input checked="" type="checkbox"/>
Transport height and width	<input checked="" type="checkbox"/>	<input checked="" type="checkbox"/>	<input checked="" type="checkbox"/>
Overall transport length	<input checked="" type="checkbox"/>	<input checked="" type="checkbox"/>	<input checked="" type="checkbox"/>

LOAD TABLE

Self weight of trailer	<input type="checkbox"/>	<input checked="" type="checkbox"/>	<input checked="" type="checkbox"/>
Weight of load carried by trailer	<input type="checkbox"/>	<input checked="" type="checkbox"/>	<input checked="" type="checkbox"/>

Weight of saddles, turntables, beams, etc.	<input type="checkbox"/>	<input checked="" type="checkbox"/>	<input checked="" type="checkbox"/>
Total weight carried by trailer	<input type="checkbox"/>	<input checked="" type="checkbox"/>	<input checked="" type="checkbox"/>
Axle loads			
Wheel contact area and pressure	<input type="checkbox"/>	<input checked="" type="checkbox"/>	<input checked="" type="checkbox"/>
"Shadow" (uniform) ground pressure imposed	<input type="checkbox"/>	<input checked="" type="checkbox"/>	<input checked="" type="checkbox"/>

STABILITY

Trailer hydraulic arrangement	<input type="checkbox"/>	<input checked="" type="checkbox"/>	<input checked="" type="checkbox"/>
Support triangle (plan)	<input type="checkbox"/>	<input checked="" type="checkbox"/>	<input checked="" type="checkbox"/>
Distance from center of gravity to support triangle	<input type="checkbox"/>	<input checked="" type="checkbox"/>	<input checked="" type="checkbox"/>
Angle of stability on end view	<input type="checkbox"/>	<input checked="" type="checkbox"/>	<input checked="" type="checkbox"/>

OPERATIONAL CONSTRAINTS

Limiting traveling speed	<input type="checkbox"/>	<input type="checkbox"/>	<input checked="" type="checkbox"/>
Limiting wind speeds for operation	<input type="checkbox"/>	<input type="checkbox"/>	<input checked="" type="checkbox"/>
Special operational restrictions (visibility, temperature, etc.)	<input type="checkbox"/>	<input type="checkbox"/>	<input checked="" type="checkbox"/>
Restrictions on approach to power lines, rail lines, quay edges, live plant, etc.	<input type="checkbox"/>	<input checked="" type="checkbox"/>	<input checked="" type="checkbox"/>
Restrictions on cross fall, incline, radius	<input type="checkbox"/>	<input checked="" type="checkbox"/>	<input checked="" type="checkbox"/>
Route study with required movements and clearances as necessary	<input checked="" type="checkbox"/>	<input checked="" type="checkbox"/>	<input checked="" type="checkbox"/>

Checkers of drawings should use the above table as a guide when checking content. Any third-party drawing for a critical lift submitted to BEO should be checked against the Category 3 criteria. If necessary, send the criteria to those producing the drawing.

9.4.3 Preparation of Detailed Drawings***9.4.3.1 Views Required******Elevation***

This view shows the relationship between the cranes and the vessel being lifted and should show all lifting attachments, as well as any structures that may cause interference. It should also show the minimum boom clearance and the clearance over foundation anchor bolts. All clearances encountered during the lift must be considered. In some cases, a boom cross section at the critical elevation will be needed to show the actual boom clearance. Include anything necessary to completely describe the lift.

Plan

This view shows the relationship of the centerline of rotation of the main lift cranes with the vessel at the initial pick and in the set positions. Include any structures adjacent to the lift. Also show any walkings or swings that must be done by the crane and the vessel's location part way through the swing, if applicable. At the set position, indicate any required rotation of the vessel and the final lug orientation. In the initial pick position, indicate which axis is up and the tailing crane to be used. Show the boom cross section at the elevation where clearance is at the minimum.

Detail of Rigging Arrangement

Show all attachments and slings exactly as they will be arranged. Show all dimensions and label all parts.

Detail of Tailing Arrangement

Provide any views necessary to show the hook-up in detail with all of the attachments to be used. Information should be just as comprehensive as the main lifting attachment. If the tailing load changes during the upending process, show the magnitude and position of the maximum value.

9.4.3.2 Refinement of Lift Equipment Selection

Having earlier established the type of equipment to be used, attempt to rationalize. Examine the actual manufacturer's capacity charts for that individual machine, and determine the most appropriate configurations in which to put the crane to optimize its use and capacity, not just on this lift but considering the project as a whole. Try to do as much as possible from one location before relocating. Try to identify one configuration that you can use to do the majority of the work; avoid too many boom changes. Note that there are often "special" duties for larger cranes that can be considered. Note also that cranes of a common denomination are not necessarily all the same. They can be equipped differently, have subtle differences in detail, or use a different boom. Do not rely on generic charts produced for publicity.

9.4.3.3 Below-the-Hook Rigging Requirements

Once a crane or lifting method has been identified, the next step is to select and design below-the-hook rigging gear. This gear may consist of any combination of slings, shackles, spreader bars, lifting beams, rigging plates, link plates, etc. Common shackle and sling sizes and capacities can be found in manufacturers' handbooks such as Crosby, Sling-Max, Lift-All, and others. Large capacity spreaders, lifting beams, and lifting plates are not usually off-the-shelf items but are custom built or rented from a specialized rigging company. BEO has developed strategic alliances with certain lifting and rental companies and can obtain heavy lift beams and bars economically. All lifting beams, spreader bars, and lifting plates need to be designed by a structural engineer and must meet ANSI requirements. Fabrication and subsequent use of these devices in the field without Engineering's approval are not acceptable. Check that your selected tackle fits the attachments designed. You would be surprised how often lift lugs are designed for no known shackle. Try to rationalize your rigging selection around a standard rigging loft that you intend to supply. That is, consider what rigging will be available and design around it as far as possible. Try to avoid changing the rigging for every lift.

Below-the-hook rigging will be arranged depending largely on the number and location of lift points (or lugs) on the vessel and the manner and direction in which they are allowed to be loaded. The simplest arrangement is for one lift point. Typically, however, there are two or more lifting points. These points must all be connected to the hook with slings, shackles, spreaders, or rigging plates. Choose slings, spreaders, and rigging plates so that all lift points are properly loaded and the load is stabilized. Avoid configurations where the slings are

unequal and one or more slings can go slack (two-point). Consider the use of a lifting frame when multiple points are involved. Consider the ability of the load to be lifted in the intended manner and beware of excessive deflection. Consider how, in the field, to adjust the level of a load having an offset center of gravity (different in practice from that anticipated), particularly where lifts must be placed to very fine limits.

9.4.3.4 Lifting Attachments

In the majority of cases, vendors will have provided items to be lifted with suitable lugs or trunnions. Handling a vessel or piece of equipment should only be done at the approved lifting locations and support points. Check with the equipment vendor or design engineer to determine if any handling limitations of the vessel or equipment are not shown on drawings. Only load the lugs in the intended directions, and never overload them. Do not design a rigging arrangement that could result in loadings not intended or allowed for by the designer of the lift attachment.

If the vendor did not supply lift lugs and no alternative method exists, request design engineering to design them. Beware of welding anything to an item in the field, particularly a pressure vessel because it will probably have been heat treated. Use bolted-on attachments where possible, and check out the item to which you are bolting to ensure that it will be adequate. Allow for the changing magnitude and direction of forces (when tailing, for example). Only a qualified structural engineer should design all such attachments.

If the rigging plan is prepared sufficiently early, it should be possible for the vendor to incorporate lugs where best needed to suit the site situation. Good communication with the vendor is essential to make this approach work. When a lug is evaluated, both the lug itself and the portion of the equipment to which it is attached must be structurally adequate. Rarely does the lug itself fail. The structure to which the lug is attached usually is the cause of failure because its strength was not considered. For example, a 1/2 inch thick lug will easily tear right out of a 3/8 inch thick tank wall if back-up or support steel is not provided. Where lifting attachments need to be fitted to an item in the field, it should be done under the supervision of an engineer. An appropriate inspection regime must be established for any welds involved (note earlier comments). Be aware that a load test may be required in such a case, whereas an alternative arrangement such as choking a sling round a suitably strong member would probably not require it.

On the rigging drawing, lift lugs or attachments required for lifting, holdback, or tailing should be shown in plan and elevation. Add section views to show location and orientation. Details of the lug or attachments should be shown or reference made to a vendor or project drawing number. In the case of stacks and thin wall units, the location of the pick point may require reinforcement. This must be shown and in place before lifting. The diagram should note whether the lug attachment is field or shop installed, if removal is required, and the procedure for removal. Detailed information, including location and orientation of shop-

installed lugs and attachments, should be furnished to the fabricator at the earliest possible date.

The angle of approach with respect to the hoisting equipment and the direction of the top, bottom, or end of a piece should be shown.

9.4.3.5 Tailing

The drawings need to include detail showing the tailing connection, indicating clearances, the type of connections, safe working loads of each component, and the factor of safety for the slings. Slings and hitches are described in Section 4 and provide more information on this subject. The use of lugs or fixtures for tailing should be considered and, in most cases, will provide for better control of the lift. If a tilt-up device is specified, consider the transfer onto the tail device, the method and required height, support during transfer, etc.

9.4.3.6 Ground Preparation

It is vital to establish a design figure for permissible ground-bearing pressure. If this is not forthcoming from the project/client, independent steps must be taken to verify the figure through testing. Lifts should be designed to minimize the imposed pressures during HL/HH operations. Using manufacturer's information, load/pressure calculation software, and spreadsheets as applicable, calculate the loads and pressures imposed at the various phases of the lift. Then specify a suitable foundation arrangement. In the worst of cases, piling may be specified. In most cases, wooden/steel mats (located on prepared ground) are used to provide a firm operating surface and distribute the load. See the guidance provided in Section 3.9. Check to determine if special mat arrangements are needed to satisfy soil-bearing capacity requirements. The number and size of mats should be shown and a detailed layout drawn to avoid edge-loading of mats. The layout and design of required mats should be coordinated with design engineering.

9.4.3.7 Receipt of the Load

Define clearly on the rigging drawings the required manner in which the item to be lifted is to be received, including direction, orientation, rotation, height, saddles, and type and size of trailer. Necessary information should be furnished to the shipper or delivering agency for proper loading and delivery to eliminate reeling at the site.

9.4.3.8 Operational Procedures

In the case of complicated lifts, consider preparation of sequence drawings showing the intentions during the different phases of the lift, the movements to be made, the equipment radii and capacities, and the changing loads throughout.

In the case of straightforward lifts, show the path of the load through the phases of the lift, radii, and capacities.

9.5 FINAL RIGGING PLANS

9.5.1 Contents of Final Rigging Plans

A rigging plan is required for each lift of which the drawings are one part. The plan provides all the details required to execute the lift operation and includes required pre-lift inspection checklists, appropriate facility permits and clearances, operator qualifications, and, most important, rigging drawings and calculations.

Typically, plans for complex operations will be a dossier of information for each lift, including the following:

- An assessment of the risks involved in the particular operation
- Special procedures in the form of written instructions establishing a system of work ensuring that these HL/HH operations are carried out safely, including:
 - Rigging drawings fully illustrating the engineer's intent and relaying it in sufficient detail to those who are to conduct the work
 - Calculations
 - Method statements
 - Procedures
 - Pre-inspection checklists
- Reference data, including:
 - Manufacturers' equipment specifications
 - Capacity charts and so on
 - Guidelines on use and manuals
 - Manufacturers' assembly instructions
 - Machine checks
- Site data, including:

- Operators' qualifications
- Approvals as required
- Work permits and clearances

9.5.2 Lift Data Sheets

A data sheet **MUST** be completed for each and every lift. This sheet summarizes all the pertinent lift and crane data in a standard format. Sample lift data sheets are shown at the end of this section. The data sheets may be incorporated directly into the rigging drawings to eliminate paperwork.

The following sections describe the items included on the lift data sheets.

9.5.2.1 Lifted Piece Description and Reference Drawing

A short description of the piece to be lifted and a reference drawing or sketch are necessary. A reference drawing **MUST** be obtained and show equipment weight, center of gravity, dimensions, lift lug locations, and other important handling instructions.

9.5.2.2 Crane Configuration

All data that pertain to the configuration of the crane must be stated in the crane configuration. Different load charts apply to different crane configurations. The exact configurations of the crane must be documented explicitly. The crane operator must be assured that the crane is configured to perform the lift that the planner envisioned. Having a summary of the crane's configuration facilitates proper crane setup.

9.5.2.3 Crane's Fixed Weight

All items hanging from the boom point are considered part of the load and must be accounted for as part of the lifted load. Read the load chart notes to confirm. These items include the hook block, wire rope, auxiliary blocks, below-the-hook rigging, and boom attachments.

9.5.2.4 Piece Weight

The total weight of the unit or vessel to be lifted must be determined from the manufacturer's data, actual scale weights, and calculations. The piece weight should be verified independently using at least two of these methods. Do not wait until the piece is attached to the hook to scale it with the crane's load indicator. The crane's load indicator should be used only as a third check. The piece weight also includes the weight of any attachments such as lifting lugs (which in some instances may be substantial). Typically, manufacturers do not include lifting attachment weights in their published equipment weights. Water weight is another item that should not be overlooked. If the piece of equipment has been sitting outdoors for any amount of time, rainwater may accumulate in fins, refractory, and fiber insulation. Thus, water could account for an additional 5 to 10 percent of the weight and must be accounted for.

9.5.2.5 Total Weight To Be Lifted

The total weight to be lifted is the sum of the fixed weight and the piece weight.

9.5.2.6 Pick Capacity

The pick capacity is the capacity of the crane when it is picking up the piece of equipment from its initial position. This capacity is the chart value for the configuration described in the crane configuration portion of the data sheet. Crane load charts typically give capacities at 5 or 10 foot radius increments and usually do not correspond exactly to the actual pick radius. For example, suppose that a load is picked up at a 17 foot radius. Because the load chart only gives values for 15 feet and 20 feet radii, the correct chart value is the 20 feet radius, which would be the lower load value. In some circumstances, it may be acceptable to interpolate between chart values, but the general rule (and safest approach) is to use the lower load value. The data sheet has been set up to accommodate this situation.

9.5.2.7 Set Capacity

The set capacity is the capacity of the crane as it is setting the piece of equipment. This capacity may or may not be more critical than the pick capacity, but it is a situation that should be considered and evaluated. The set capacity is denoted as a percentage of the chart capacity and must be below 100 percent.

9.5.2.8 Clearances

Boom and obstruction clearances must be evaluated for each stage of a lift. Spreader bars and lift beams should be examined closely because they are typically as wide as the load and are the first items to interfere with the boom if the load is swiveled. Minimum clearances should be calculated and documented on the data sheet. The minimum sling safety factor is determined by dividing the known breaking strength rating for the sling wire used by the weight lifted times the governing efficiency factor. The minimum clearance from the rigging diagram should be stated here.

9.5.2.9 Two Crane Lifts

The data sheet for two crane lifts is similar to the one-crane sheets. The only difference is that there are two cranes and the piece weight must be divided. A static calculation or other rational procedure must be attached to the data sheet describing the basis for the load split.

9.5.3 Method Statement Policy

BEO recognizes its obligation to provide for a safe system of work in all its activities. Much of what it undertakes is potentially hazardous and the preparation of a written method statement for a task is an important tool in planning for a safe system of work in these cases. Before work begins, the task to be undertaken is assessed for size and complexity; if the task warrants it, a method statement is produced to an appropriate level of detail.

Bechtel's policy is to provide outline proposals for critical lifts and moves at a tender stage, including drawings, equipment ratings, and a brief method statement. This outline is developed post award into a working method statement that, on larger projects, will form part of the lift/transport manual for the project.

The method statement for a lift or move is a single document containing all of the instructions necessary to undertake the work in a safe manner. The method statements are designed to be clear and unambiguous, describing the work to be undertaken in logical sequence from start to completion. They cross reference the drawings for the work and any other standard procedures to be adopted. Limitations in the engineering and other particular points of note are highlighted. Any safety instructions and permit requirements are appended.

Standard tasks (such as erecting heavy cranes) have standard method statements. These are incorporated in the dossier/manual for the project.

The method statements are indexed for ease of reference and are marked with a date of preparation and a revision number. To keep them current, they are reviewed as often as is necessary and re-issued. Copies are issued to all concerned with the supervision of the operation, and the skilled operators are briefed from the copies.

All involved are responsible for complying with the method statement. A person is appointed to police the operations, either the site manager or supervisor. On larger projects, a dedicated safety officer may be appointed and is tasked with overseeing compliance.

9.5.4 Project Lift Manual

On a large project where there are many lifts, the dossiers being the lift plans for each lift will be collated into one document, the lift manual. This is the definitive record of the work and an integral part of the quality assurance and control procedures.

9.6 EXAMPLES OF TYPICAL RIGGING DRAWINGS

The following detailed rigging drawings show the required level of detail:

CRANE DATA - START UP

CRANE	CC400
CONFIGURATION	SIL
LENGTH	135
WIDTH	135
HEIGHT	445
EXTENDED CTW RADIUS	65.5 FT
CTW	131 FT
AW	131 FT
NO. PAIRS	2/4
RADIUS	92.0 FT (AW)
CAPACITY	271,000 LBS
LOAD	37,000 LBS
WIND	100 MPH
WINDSPEED	100 MPH
% CAPACITY	84%

CRANE DATA - FINISH UPEND

CRANE	CC400
CONFIGURATION	SIL
LENGTH	135
WIDTH	135
HEIGHT	445
EXTENDED CTW RADIUS	65.5 FT
CTW	131 FT
AW	131 FT
NO. PAIRS	2/4
RADIUS	91.0 FT (AW)
CAPACITY	261,000 LBS
LOAD	37,000 LBS
WIND	100 MPH
WINDSPEED	100 MPH
% CAPACITY	87%

IMPORTANT NOTES ON SHEET 3 11

Bechtel Equipment Operations, Inc.
Rigging Department, Louisville, KY
P.O. BOX 10000
LOUISVILLE, KY 40201

DATE: 10/20/00
DRAWN: [Name]
CHECKED: [Name]
APPROVED: [Name]

SHEET 1 OF 3

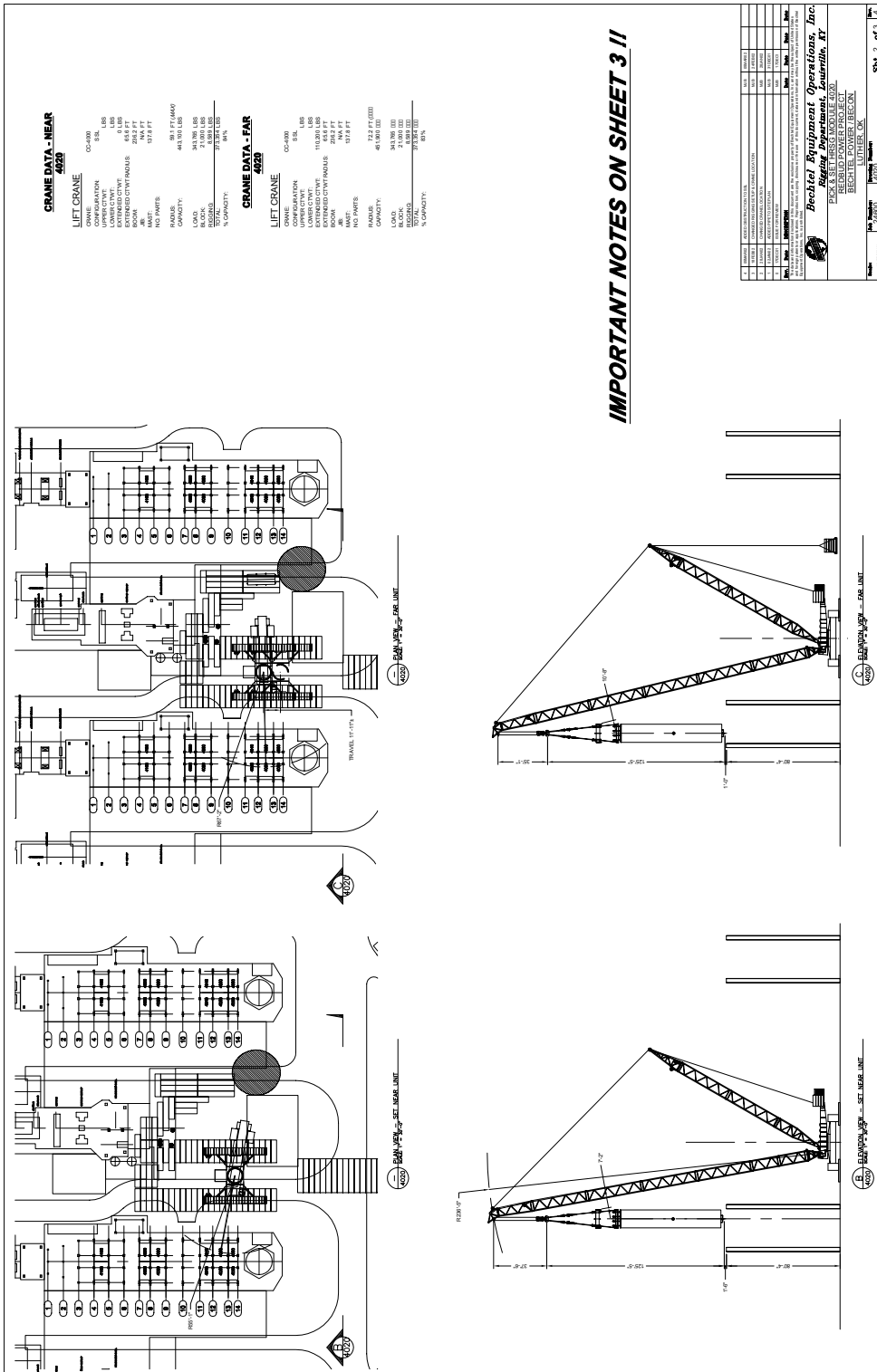

CRANE DATA - NEAR
4420

LIFT CRANE

CONFIGURATION	CC-400
S.W.	45,000 LBS
LOWEST COUNTERWEIGHT	112,000 LBS
EXTENDED COUNTERWEIGHT RADIUS	65.0 FT
WIND SPEED	104 FT
NO. PILES	107 PILES
RADIUS	80.7 FT (MAX)
CAPACITY	443,100 LBS
LOAD	341,700 LBS
WIND	104 FT
WIND SPEED	104 FT
% CAPACITY	84%

CRANE DATA - FAR
4420

LIFT CRANE

CONFIGURATION	CC-400
S.W.	45,000 LBS
LOWEST COUNTERWEIGHT	112,000 LBS
EXTENDED COUNTERWEIGHT RADIUS	65.0 FT
WIND SPEED	104 FT
NO. PILES	107 PILES
RADIUS	80.7 FT (MAX)
CAPACITY	443,100 LBS
LOAD	341,700 LBS
WIND	104 FT
WIND SPEED	104 FT
% CAPACITY	84%

IMPORTANT NOTES ON SHEET 3 !!

NO.	DESCRIPTION	DATE	BY	CHECKED
1	ISSUED FOR CONSTRUCTION	10/15/00
2	ISSUED FOR CONSTRUCTION	10/15/00
3	ISSUED FOR CONSTRUCTION	10/15/00
4	ISSUED FOR CONSTRUCTION	10/15/00
5	ISSUED FOR CONSTRUCTION	10/15/00
6	ISSUED FOR CONSTRUCTION	10/15/00
7	ISSUED FOR CONSTRUCTION	10/15/00
8	ISSUED FOR CONSTRUCTION	10/15/00
9	ISSUED FOR CONSTRUCTION	10/15/00
10	ISSUED FOR CONSTRUCTION	10/15/00

Bechtel Equipment Operations, Inc.
Region Department, Louisville, KY
P.O. BOX 10000, LOUISVILLE, KY 40201
BECHTEL POWER REGION
LOUISVILLE, KY
40201

SN 2 of 4

10. Glossary

The following is a glossary of common rigging terms and expressions.

ABRASION - Surface wear on the wires of a wire rope.

ACCELERATION STRESS - Additional stress imposed on a wire rope due to increasing velocity of load.

ACCESSORY - A secondary part of assembly of parts which contributes to the overall function and usefulness of a machine.

A-FRAME - See Gantry.

A-FRAME DERRICK - A derrick in which the boom is hinged from a cross-member between the bottom ends of two upright members spread apart at the lower ends and joined at the top; the boom point secured to the junction of the side members, and the side members are braced or guyed from this junction point.

ALBERT'S LAY - Synonymous with Lang Lay.

ALTERNATE LAY - Lay of a wire rope in which the strands are alternately regular and Lang Lay.

ALTERNATIVE LAY - SPECIAL - A rope that has two Lang Lay strands alternating with one Regular Lay strand.

ANGLE INDICATOR (BOOM) - An accessory which measures the angle of the boom above the horizontal position.

AREA, METALLIC - Sum of the cross-sectional areas of individual wires in a wire rope or strand.

ATTACHMENT - Any other device that may be added as a complete unit or assembly.

AXIS OF ROTATION - The vertical line through the axis around which the crane superstructure rotates.

AXLE - The shaft or spindle about which a wheel revolves. On truck and wheel mounted cranes, it refers to an automotive type of axle assembly including housing, gearing, differential, bearings, and mounting appurtenances.

AXLE, LIVE - Driven axle.

AXLE, TAG - Non-powered rear axle (not driven); follows the drive axle.

AXLE, PUSHER - Non-powered rear axle, located ahead of the drive axle.

AXLE (BOGIE) - Two or more axles mounted in a frame so as to distribute the load between the axles and permit vertical oscillation of the wheels.

BACKHITCH GANTRY - A structural frame, located to the rear of the revolving superstructure and usually extending above the cab. Retractable means are usually available to lower the cab height for roadable convenience. Its purpose is to support the boom hoist's derricking system.

BACKSTAY - A guy used to support a boom or mast, or that section of a main cable, as on a suspension bridge, cableway, etc., leading from the tower to the anchorage.

BACKWARD STABILITY - Resistance to overturning of a crane in rearward direction.

BAIL - The U-shaped member of a shackle, socket or other fitting.

BAIL BLOCK - A block attached to a shovel or hoe dipper, through which rope line is reeved. Also referred to as a Padlock.

BALLAST - See Counterweight.

BAND BRAKE - Circular type of brake of an external contracting type, having a strap lined with heat and wear resistant friction material.

BARREL - The lagging or body portion of a rope drum.

BASE (MOUNTING) - The traveling base upon which the revolving superstructure is mounted, such as a car, truck, or crawler wheel platform.

BASE (ROTATING) - See Revolving Superstructure

BASE (TURNTABLE) - See Revolving Superstructure

BASKET DERRICK - A derrick without a boom, similar to a gin pole, with its base supported by ropes attached to corner posts or other parts of the structure. The base is at a lower elevation than its supports. The location of the base of a basket derrick can be changed by varying the length of the rope supports. The top of the pole is secured with multiple reeved guys to position the top of the pole.

BASKET HITCH - The sling configuration underneath a load used to form two parts of wire rope for lifting.

BASKET OF SOCKET - The conical portion of a socket into which a splayed rope end is inserted and secured with zinc.

BECKET - An anchor or tie-off point for the dead end of a live line.

BECKET LOOP - A loop of small rope or strand fastened to the end of a large wire rope to facilitate installation.

BENDING STRESS - Stress imposed on the wires of a wire rope by bending.

BOLSTER - Attachment to a trailer to support load, which can be fixed or can oscillate in one, two, or three directions.

BOOM - A timber, metal section or strut which is pivoted or hinged at the heel (lower end) at a location fixed in height on a frame, mast, or vertical member, with its point (upper end) supported by chains, ropes, or rods to the upper end of the frame, mast, or vertical member. A rope for raising and lowering the load is reeved through sheaves or a block at the boom point.

BOOM ANGLE - The angle above the horizontal position of the straight line, joining the centerline of the boom's foot pin and centerline of the boom's point load'hoist sheave pin.

BOOMCHORD - A main corner member of a lattice type boom.

BOOM HARNESS - See Boom Hoist Equalizer.

BOOM HOIST EQUALIZER - A block and sheave assembly in which the topping lift cable is reeved in such a way that the tensions in the boom support pendants are equal.

BOOM LACING - Structural truss members placed at angles to a lattice type boom and supporting the boom chords.

BOOM LENGTH - The straight line distance from the centerline of a boom's foot pin to centerline of a boom's point load'hoist sheave pin.

BOOM LINE - A wire rope used for supporting or operating the boom on derricks, cranes, drag lines, shovels, etc.

BOOM POINT - The outward end of the top section of the boom.

BOOM SECTION - Basic crane booms are usually in two sections, upper and lower. Such booms may be lengthened by insertion of one or more additional sections.

BOOM SPLICES - Splicing connections for sections of basic crane booms and additional sections, usually of the splice plate type, pin type or butt type.

BOOM STOP - A device used to limit the angle of the boom to the highest recommended boom angle.

BREAST DERRICK - A derrick without a boom. The mast consists of two side members spread farther apart at the base than at the top and tied together at the top and bottom by rigid members. The mast is prevented from tipping forward by guys connected to its top. The load is raised and lowered by ropes through a sheave or block secured to the top crosspiece.

BRIDGE SOCKET - Steel castings with baskets for securing rope ends and equipped with adjustable bolts. A closed type has Unbolt and an open type has two eyebolts and pin.

BRIDLE - See Boom Hoist Equalizer.

BRIDGE SLING - A two-part wire rope sling attached to a single-part line. The legs of the sling are spread to divide and equalize the load.

BRIGHT ROPE - Wire rope made of wires that are not coated with zinc or tin.

BUTT SECTION (INNER) - Portion of the boom that is hinged to the revolving deck.

CAB - A housing which covers the revolving superstructure, machinery, and operator's station. On a truck crane, there is a separate cab to cover the driver's station.

CABLE - A term loosely applied to wire ropes, wire strands, manila ropes and electrical conductors.

CABLE-LAID WIRE ROPE - A type of wire rope consisting of several wire ropes laid into a single wire rope. Example: 6 x 6 x 7 tiller rope.

CAR BODY - See Base Mounting.

CENTER PIN - Vertical pin or shaft which acts as a rotation centering device and connects to the revolving superstructure and base mounting.

CHOCKING - Used to keep round vessel from rolling and usually made of timber wedges.

CHASSIS - The framework of a vehicle including all parts necessary for its operation.

CHICAGO BOOM DERRICK - A boom which is attached to an outside upright member of the structure serving as the mast, and the boom is stepped into a fixed socket clamped to the upright. The derrick is complete with load, boom, and boom point swing line falls.

CHOKER - Sling hitch used to form a slip noose around the object to be moved or lifted.

CIRCUMFERENCE - Measured perimeter of a circle circumscribing the wires of a strand or the strands of a wire rope.

CLAMSHELL EQUIPMENT - Machines with clamshell attachments which are used to load material from stock piles, gondola cars, barges, and the like, or from virgin soil generally out of small area holes, deep trenches, or from below water. Orange peel bucket grapples and similar attachments are included in this classification.

CLASSIFICATION - Group or family of wire rope construction having common strengths and weights.

CLEVIS - See Shackle.

CLOSED SOCKET - Wire rope and fitting consisting of basket and bail made integral.

COIL - Circular bundle or wire rope not packed on a reel.

COMMON STRAND - Galvanized strand made of galvanized iron wire. See Grades, Strand.

CONICAL DRUM - Grooved hoisting drum of varying diameter.

CONSTRUCTION - Design of wire rope including number of strands, number of wires per strand and arrangement of wires in each strand.

CONTINUOUS BEND - Reeving of wire rope over sheaves and drums so that it bends in one direction, as opposed to reverse bend.

CORE - Core member of a wire rope about which the strands are laid. It may be fiber, a wire strand, or an independent wire rope.

COUNTERWEIGHT - Weight used to supplement the weight of the machine in providing stability for lifting working loads and usually attached to the rear of a revolving superstructure. Also called Ballast.

COVER WIRES - Outer layer of wires.

CRAWLER CHAIN - Chain used as the final drive to the crawler belt.

CRAWLER MOUNTING - Two continuous, parallel crawler belts, consisting of a series of tread shoes or links encompassing rollers and drive tumblers, supporting a base frame which houses the propelling mechanism, driven and controlled from a revolving superstructure.

CROSS LAY - A multiple layered rope or strand in which the lay of the inner wire layer is opposite to the lay of the outer layer.

CROSSOVER - See Boom Hoist Equalizer.

CROWD - Outward movement of the dipper stick in relation to its axis on the boom.

CUFFING - See Derricking.

CYLINDRICAL DRUM - Hoisting drum of uniform diameter.

DEAD MAN - Buried object in the ground used to secure guy wires.

DEFLECTION - (a) Sag of a rope in a span; usually measured at mid-span as the depth from the chord joining the tops of the two supports.

(b) Any deviation from a straight line.

DERRICK - An apparatus consisting of a mast or equivalent member, held at the head by guys or braces, with or without a boom, and used with a hoisting mechanism and operating ropes.

DERRICK BULLWHEEL - A horizontal ring or wheel which is fastened to the foot of a derrick for the purpose of turning the derrick by means of ropes leading from this wheel to a powered drum.

DERRICKING - Operation of changing the boom angle in a vertical plane. See Boom Hoist Equalizer.

DIAMETER - Distance measured across the center of a circle circumscribing the wires of a strand or the strands of a wire rope.

DIPPER - A material container rigidly attached to a machine. See Shovel Dipper and Hoe Dipper.

DOGS (PAWL AND RACHET) - Devices for locking the motion or movement of hoisting drums.

DRAGLINE EQUIPMENT - Machines with dragline attachments are generally used to excavate material from below the grade on which the machine is placed.

DRIVE TUMBLER - A roller with teeth or lugs which contacts matching recesses, lugs, or pins in the crawler belt.

DROMEDARY - Long wheelbase tractor using a body or container between the fifth wheel and cab.

DRUM (ROPE) - A rotating cylinder with side flanges on which rope used in machine operations is wrapped.

DUAL CROWD - A type in which the reaction from dead end of the hoist hitch is used to assist crowding of the dipper and where an independent crowding mechanism is also provided.

EFFICIENCY (SLING) - Percentage ratio of the measured breaking strength of a sling to the strength of the wire rope tested separately.

ELASTIC LIMIT - Limit of stress above which a permanent deformation takes place within the material.

ENDLESS ROPE - Rope whose two ends are spliced together.

EQUALIZING THIMBLES - Special type of fitting used as a component part of some wire rope slings.

EXTRA HIGH STRENGTH STRAND - A grade of galvanized or bright strand.

EYE OR EYE SPLICE - A loop, with or without a thimble, formed at the end of a wire rope.

FAIRLEAD - A device to guide wire rope for proper spooling.

FALL ROPE - Wire rope in the falls or tackle.

FIBER CORES (CENTERS) - Cords or rope made of vegetable or synthetic fiber used in center of wire rope (strand).

FIDDLE BLOCK - A block consisting of two sheaves in the same plane held in place by the same cheek plates.

FIFTH WHEEL - Circular metal plate secured to the chassis frame, which engages the trailer's kingpin, permitting trailer to pivot.

FITTING - Any accessory used as an attachment for wire rope.

FILLER WIRE - Small auxiliary wires in a strand for spacing and positioning other wires.

FLAG - Marker on a rope to designate position of load.

FLANGE LUG - Usually bolted to the top flange of a vessel for lifting.

FLAT ROPE - Wire rope made of parallel alternating right lay and left lay ropes, sewn together by relatively soft wires.

FLATTENED STRAND ROPE - A wire rope with either oval- or triangular-shaped strands which presents a flattened rope surface.

FLEET ANGLE - Angle between position of a rope at the extreme end wrap on a drum, and a line drawn perpendicular to the axis of the drum through the center of the nearest fixed sheave.

FLOATING HARNESS - See Boom Hoist Equalizer.

FOOT BEARING OR BLOCK (SILL BLOCK) - The lower support on which the derrick mast rotates.

G.C.W. - Gross combination weight. Total weight of a fully-equipped tractor, trailer, or trailers and payload.

G.T.W. - Gross train weight. Same as G.C.W.

G.V.W. - Gross vehicle weight. Total weight of fully-equipped truck and payload.

GALVANIZE - To coat with zinc to protect against corrosion.

GANTRY - (A FRAME) - A crane gantry is a structure mounted on the revolving superstructure of the machine to which the boom supporting ropes are attached.

GEAR RATIO, AXLE - Ratio of the speed of the propeller shaft to the speed of the rear axle shaft.

GEAR RATIO, TRANSMISSION - Ratio of the input shaft's speed to the speed of the output shaft.

GEAR RATIO, SLOW - High numerical ratio, such as 9.00 to 1.00 (low speed).

GEAR RATIO, FAST - Low numerical ratio, such as 3.00 to 1.00 (high speed).

GIN POLE - Compression member guyed from the top and pinned or in a socket at its base; usually used in pairs. The load is raised and lowered by ropes reeved through sheaves and blocks at the top of the pole.

GIN POLE DERRICK - Single live gin pole with its guys arranged to permit leaning the pole in any direction. The load is raised and lowered by ropes reeved through sheaves or blocks at the top of the pole.

GLAD HANDS - A separable mechanical connector used to join air hoses when combination vehicles are coupled together.

GOOSENECK BOOM - A boom which has an integral upper section projecting at an angle longitudinal to the axis of the lower section.

GRADES, ROPE - Classification of wire rope by their breaking strengths. In order of increasing breaking strengths, they are:

- Iron
- Traction
- Mild Plow Steel
- Plow Steel
- Improved Plow Steel
- Extra Improved Plow Steel
- Double Extra Improved Plow Steel

GRADES, STRAND - Classification of strand by breaking strengths. In order of increasing breaking strengths, they are:

- Common
- Siemens Martin
- High Strength
- Extra-High Strength

A utilities grade strand is also made to meet special requirements.

GRADEABILITY - Percent grade that a vehicle will negotiate.

GROMMET - An endless wire rope made from one continuous length of strand or wire rope, layed upon itself six times to form a rope composed of seven parts of wire rope or strand.

GROOVED DRUM - Drum with a grooved surface to accommodate and guide the rope.

GROUSER - Projecting lugs attached to, or integral with, crawler tread shoes to provide additional traction.

GUDGEON PIN - A pin connecting the mast cap to the mast, allowing rotation of the mast.

GUY (LINE) - A rope used to steady or secure the mast or other member in the desired position.

GUY DERRICK - A fixed derrick consisting of a mast capable of being rotated, supported in a vertical position by guys, and a boom whose bottom end is hinged or pivoted to move in a

vertical plane with a reeved rope between the head of the mast and boom point for raising and lowering the load.

HAMMER HEAD BOOM - A boom on which both the hoist and boom suspension lines are offset from the centerline of the boom for load clearance.

HAWSER - Wire rope, usually galvanized, used for towing or mooring vessels.

HELPER SPRING - Additional spring device permitting greater load on an axle.

HOE EQUIPMENT - Machines with hoe attachments are used to excavate hard or loose material from below the grade on which the hoe stands. Hoe equipment includes: a boom, a dipper arm mounted to rotate vertically about an axis on the boom, a dipper attached to the dipper arm, and hoe units.

HOOK BLOCK - Block with hook attached used in lifting service. It may have a single sheave for double or triple line, or multiple sheaves for four or more parts of line.

HOOK ROLLERS - Rollers which prevent the lifting of the turntable from the base.

IDLER - SHEAVE - Used to guide or support a rope.

IDLER ROLLER - Rollers of a tread belt mechanism which are not power driven.

IDLER TUMBLER - Large end roller of crawler belt mechanism at the opposite end of the drive tumbler which is not power driven.

IMPROVED PLOW STEEL ROPE - See Grades, Rope.

INDEPENDENT CROWD or POSITIVE CROWD - A type driven by either a cable or a chain — or a combination of both — from the reversing mechanism on a revolving superstructure.

INDEPENDENT BOOM HOIST, SWING, AND TRAVEL - A drive independent of all other functions.

INDEPENDENT WIRE ROPE CORE (IWRC) - Wire rope used as the core of a larger rope.

INNER WIRES - All wires of a strand except the surface or cover wires.

INTER-AXLE DIFFERENTIAL - A gear device equally dividing the power between axles and compensating for unequal tire diameters.

INTERNALLY LUBRICATED - Wire rope or strand having all wires coated with lubricant.

JIB or BOOM TIP EXTENSIONS - An extension attached to the boom head to provide added boom length for handling specified loads. The jib may be in line with the boom or may be offset.

LACING - See Boom Lacing; also method of reeving blocks.

LAGGING - Grooved drum spool shells.

LANG LAY ROPE - Wire rope in which the wires in the strands and the strands in the rope are laid in the same direction.

LATTICED BOOM - Boom of open construction with angular or tubular lacing between main corner members in the form of a truss.

LAY - Manner in which wires are helically laid into strands or strands into rope.

LEFT LAY - (a) Strand - Strand in which the cover wires are laid in a helix having a left-hand screw.

(b) Rope - Rope in which the strands are laid in a helix having a left-hand pitch, similar to a left-hand screw.

LENGTH OF LAY - See Pitch.

LIFTING CAPACITY - See Rated Loads, Net Load, Practical Working Loads.

LIFTING LUG - Attachment used in lifting equipment.

LIVE ROLLER CIRCLE - An assembly of multiple swing rollers free to roll between a revolving superstructure and mounting.

LOAD - See Rated Load, Net Load and Practical Load.

LOAD BLOCK - See Hook Block.

LOAD BLOCK, LOWER - The assembly of sheaves, pins and frame suspended from the hoisting rope.

LOAD BLOCK, UPPER - The assembly of sheaves, pins and frame suspended from the boom by solid links or direct connection.

LOAD LINE - Another term for Hoist Line. In the lifting crane service it refers to the main hoist. The secondary hoist is referred to as a Whip Line.

LOAD MOMENT INDICATOR (LMI) - A device, that when fitted to a crane, automatically gives, within specified tolerance limits, a warning of the approach to the safe working load on the crane and a further warning when the safe working load has been exceeded.

LOCKED COIL STRAND - Smooth-surfaced strand composed of shaped wires laid in concentric layers around a center of round wires.

MAGNET EQUIPMENT - Machines with magnet attachments used to handle ferrous products in either the form of raw materials such as pig iron and scrap, or semi-finished billets, plates, and castings.

MAIN DRUMS - Main drums are used for lifting and lowering loads, to operate excavating attachments, and for other purposes. Two main drums and an operating mechanism usually are

provided. Some manufacturers offer a third drum for special operations.

MARLINE SPIKE - Tapered steel pin used in splicing or inspecting wire rope.

MAST - Frame hinged at or near the boom hinge point and extending above the case for use in connection with supporting a boom.

LIVE MAST - Topping lift rope raises and lowers the mast. The boom is connected to the mast with pendants.

FIXED MAST - Mast is fixed in position with back hitch pendants to the gantry. The boom is raised and lowered by connecting the topping left reeving between the mast top and boom tip.

MAST CAP (SPIDER) - The fitting at the top of the mast or gin pole to which the guys are connected.

MATS - Supports or floats used for supporting machines on soft ground — usually of timber construction.

METALLIC CORES - See Wire Strand Core and Independent Wire Rope Core.

MILD PLOW - See Grades, Rope.

MOORING LINES - Galvanized wire rope — usually 6x12 or 6x24 — of spring lay construction, used for holding ships to docks.

NET LOAD - Net load is the weight of material that can be handled. It is determined by deducting the weight of the auxiliary load handling equipment such as hooks, hook blocks, slings, buckets, magnets, pile drive leads, etc. from the rated loads.

NON-PREFORMED - (NON. PREF.) - The wires and or strands are not shaped to the helical form they assume in the strand.

NON-ROTATING WIRE ROPE - 18x7 wire rope consisting of a 6x7 left lay and lay inner rope is covered by twelve 7-wire strands right lay regular lay.

NON-SPINNING WIRE ROPE - See Non-Rotating Wire Rope.

OPEN SOCKET - Wire rope fitting consisting of a Basket and two Ears with a pin.

OUTER WIRES - See Cover Wires.

OUTRIGGERS - Extendible arms attached to the mounting base, which rest on supports at the outer ends to increase stability.

PAY LOAD - See Net Load.

PEENING - Permanent distortion of outside wire in a rope caused by pounding.

PENDANTS - A supporting rope which maintains a constant distance between the points of attachments to the two components connected by the rope.

PINTLE HOOK - Coupling at the rear of a truck for the purpose of towing a trailer or other units.

PITCH - The distance parallel to the axis of the rope (or strand) in which a strand (or wire) makes one complete helical convolution about the core (or center). Also known as length of lay.

PITCH DIAMETER - Root diameter of drum, lagging or sheave, plus the diameter of the rope.

PITMAN ARM - Steering gear arm which attaches to drag link.

PLOW STEEL - See Grades, Ropes.

POWER CONTROLLED LOWERING - In the lifting crane service, some manufacturers offer Power Controlled Lowering by a reversing mechanism in the power train to one or more of the drums to provide a limited lowering speed and reduce demand on the drum brake.

PRACTICAL WORKING LOAD - Practical working load is that load established for the particular job by the equipment user with due allowance for operating conditions. These conditions include the supporting ground and other factors affecting stability, wind, hazardous surroundings, experience of personnel, etc.

PREFORMED STRAND - Strand in which the wires are permanently shaped before fabrication to the helical form they assume in the strand.

PREFORMED WIRE ROPE - Wire rope in which the strands are permanently shaped before fabrication to the helical form they assume in the wire rope.

PRESSED FITTING - A fitting in which a wire rope is attached, after insertion, by pressing the shank enclosing the rope. See Swaged Fitting.

PRESTRESSING - Stressing a wire rope or strand before use under such a tension and for such a time that the constructional strength is largely removed.

PROPORTIONAL BEAM - Beam used to proportion the load lifted to each crane in a two crane lift.

PUP - A short semitrailer used in combination with a dolly and another semitrailer to create a twin trailer.

PULL BLOCK - See Bail Block.

RADIUS OF LOAD - The horizontal distance from a projection of the axis of rotation to the supporting surface to the center of vertical hoist line or tackle with the load applied.

RATED LOAD (OF CRANE) - Rated loads at specified radii are the lesser of a specified percentage of tipping loads or the machine's structural competence as established by the manufacturer, and are the maximum loads at those radii covered by the manufacturer's warranty.

REEVING - A rope system where the rope travels around drums and sheaves.

REGULAR LAY ROPE - Wire rope in which the wires in the strands and the strands in the rope are laid in opposite directions.

RETARDER - An auxiliary speed reducing device. The retardation is generated by a moving vehicle.

REVERSE BEND - Reeving of a wire rope over sheaves and drums so that it bends in opposite directions.

REVERSE LAY - See Alternate Lay.

REVOLVING SUPERSTRUCTURE - The rotating frame and machinery located thereon, except the power plant, for operating the machine.

RIGHT LAY - (a) Strand - Strand in which the cover wires are laid in a helix having a right-hand pitch, similar to a right-hand screw.

(b) Rope - Rope in which the strands are laid in a helix having a right-hand pitch, similar to a right-hand screw.

RIM PULL - Actual amount of effort in pounds available at the point of contact of tire and road surface.

ROLLER PATH (OF CRANE) - The surface upon which run the rollers that support revolving superstructure. It may accommodate either cones or cylindrical rollers.

ROLLING RESISTANCE - Sum of the forces at the area of contact between a vehicle's tires and road surface acting against the direction of movement.

ROTATING BASE - See Revolving Superstructure.

SADDLE - Device to support round vessels, etc., which protects the shell and spreads out loads. A saddle can be used in place of chocking to keep a load from rolling.

SAFETY HOOK - A hook with a latch to prevent slings or load from accidentally slipping off the hook.

SAFE WORKING LOAD - The proper load in which the rope, shackle, etc. may carry as determined by manufacturers' data, tests, and applicable codes.

SPECIALIZED CARRIERS AND RIGGING ASSOCIATION (SC&RA) - An international association serving members engaged in the crane, rigging and oversize/overweight transportation industries.

SEALE - A strand construction having one size of cover wires with the same number of one size of wires in the inner layer and each layer having the same length and direction of lay. The most common construction is one center wire, nine inner wires.

SEIZE - To bind securely the end of a wire rope or strand with wire or strand.

SELF ERECTION RIGGING - Rope reeved through sheaves for the purpose of erecting the mast and boom. Does not carry any of the load under working conditions.

SHACKLE - A U-shaped fitting with a pin.

SHEARLEG DERRICK - A derrick without a boom and similar to a Breast Derrick. The mast, wide at the bottom and narrow at the top, is hinged at the bottom and has its top secured by a multiple-reeved guy to permit handling loads at various radii by means of load tackle suspended from the mast top.

SHEAVE - A grooved pulley for use with rope.

SIDE LOADING - A load applied at an angle to the vertical plane of the boom.

SILL - A member connecting the foot block and stiffleg, or a member connecting the lower ends of a double member mast.

SLINGS, BRAIDED - A very flexible sling composed of several individual wire ropes braided into a single sling.

SLIPTORQUE - Torque required to slip wheels.

SMOOTH FACED DRUM - Drum with a plain face, not grooved.

SOCKET - Type of wire rope fitting. See Bridge Sockets, Closed Sockets, Open Sockets, and Wedge Sockets.

SPIRAL GROOVE - Groove which follows the path of a helix around the drum as the thread of a screw.

SPLICING - Interweaving of two ends of ropes so as to make a continuous or endless length without appreciably increasing the diameter. Also, making a loop or eye in the end of a rope by tucking the ends of the strands.

SPREADER BAR - A member used to make slings vertical from the object lifted; theoretically, a compression member.

SPREADER BEAM - Same function as the Spreader Bar, but uses less headroom; a bending member.

STABILITY - The ability of a mobile machine to resist tipping; does not normally apply to a stationary mounting.

STANDING ROPE - See Guy Line.

STEEL CLADROPE - Rope with individual strands spirally wrapped with flat steel wire.

STIFFLEG - Rigid member supporting the mast at the head.

STIFFLEG DERRICK - A derrick similar to a guy derrick except that the mast is supported or held in place by two or more stiff members, called stifflegs, which are capable of resisting either tensile or compressive forces. Sills are generally provided to connect the lower ends of the stifflegs to the foot of the mast.

STIRRUP - The U-bolt or eyebolt attachment on a bridge socket.

STRAND - An arrangement of wires helically laid about an axis, or another wire or fiber center to produce a symmetrical section.

STRAND CENTER - See Centers.

STRAND CORE - See Cores.

STRUCTURAL COMPETENCE - The ability of the machine and its components to withstand the stresses imposed by applied loads.

SUSPENSION - Attaching parts, including springs, for securing an axle or axles to a chassis frame.

SWAGED FITTINGS - Fittings in which wire rope is inserted and attached by cold flowing method.

SWING - The function of revolving the superstructure of the machine.

SWING BEARING - A combination of rings with balls or rollers capable of sustaining radial, axial or overturning loads of the revolving superstructure.

SWING BRAKE - A swing brake is a friction device to hold the revolving superstructure in any desired position relative to the mounting.

SWING GEAR - External or internal gear with which a swing pinion on a revolving superstructure meshes to provide the swing motion.

SWING LOCK - A mechanical device to lock the revolving superstructure to the mounting in established positions.

SWING MECHANISM - The machinery involved in providing dual directional rotation of the revolving superstructure.

SWING RADIUS - The distance from the center of rotation to the hook of a freely suspended load.

SWING SPEED - The speed, in revolutions per minute, at which the revolving superstructure rotates.

TACKLE (HOIST) - Assembly of ropes and sheaves arranged for pulling.

TAG LINE - A rope used to prevent rotation of a load.

TAIL SWING - Distance from the center of rotation to the maximum rear extension of a revolving superstructure.

TANDEM DRIVE - Two axle drive combination.

THIMBLE - Grooved metal fitting to protect the eye of a wire rope.

THIRD DRUM - A third hoist drum in addition to two main hoist drums, often used in pile driving and as the whip line.

TINNED WIRE - Wire coated with tin.

TIPPING CONDITION - A machine is considered to be at the point of tipping when a balance is reached between the overturning moment of the load and the stabilizing moment of the machine when on a firm, level supporting surface.

TIPPING LOAD - Tipping load is the load producing a tipping condition at a specified radius. It includes the weights of hook, hook blocks, slings, etc., plus weight on the hook.

TIRE SIZES - These are specified by diameter of casing, diameter of wheel and ply rating, i.e., 9.00 x 20-10 ply is a 9-inch diameter casing on a 20-inch diameter wheel or rim, and is of 10-ply construction.

TORQUE CONVERTER - Hydraulic torque multiplier operating as a fluid coupling.

TOWER ATTACHMENT - A crane attachment adaptable to a basic crane machine. The attachment consists of a vertical tower with a working boom affixed to the upper part of the tower.

TRACTIVE EFFORT - The amount of force available at the driving tires of a vehicle.

TRAVEL MECHANISM - The machinery involved in providing travel.

TREAD SHOES - Hinged steel pads joined to form a continuous crawler belt which supports the machine.

TRUCK CRANE - Crane mounted on an independent engine-driven rubber-tire carrier.

TUMBLER - One of the large sprockets for a crawler belt. See Idler Tumbler and Drive Tumbler.

TURNBUCKLE - Device attached to wire rope for making limited adjustments in length. It consists of a barrel and right and left hand threaded bolts.

TWO BLOCK DISTANCE - Distance measured from boom point sheave pin to sheave pin of traveling (lower) blocks.

WARRINGTON - A strand construction in which one layer of wires, usually the outer, is composed of alternating large and small wires.

WEDGE SOCKET - Wire rope fitting in which the rope end is secured by a wedge.

WHEELBASE - Distance between centerlines of front and rear axles or to centerline of tandem axles.

WHIPLINE - Secondary hoist line. Also see Load Line.

WIRE - Single continuous length of metal, round or shaped, cold drawn from a rod.

WIRE ROPE - A plurality of strands laid helically around an axis or a core.

WORKING WEIGHT - Weight of machine in working order with complete front end equipment.

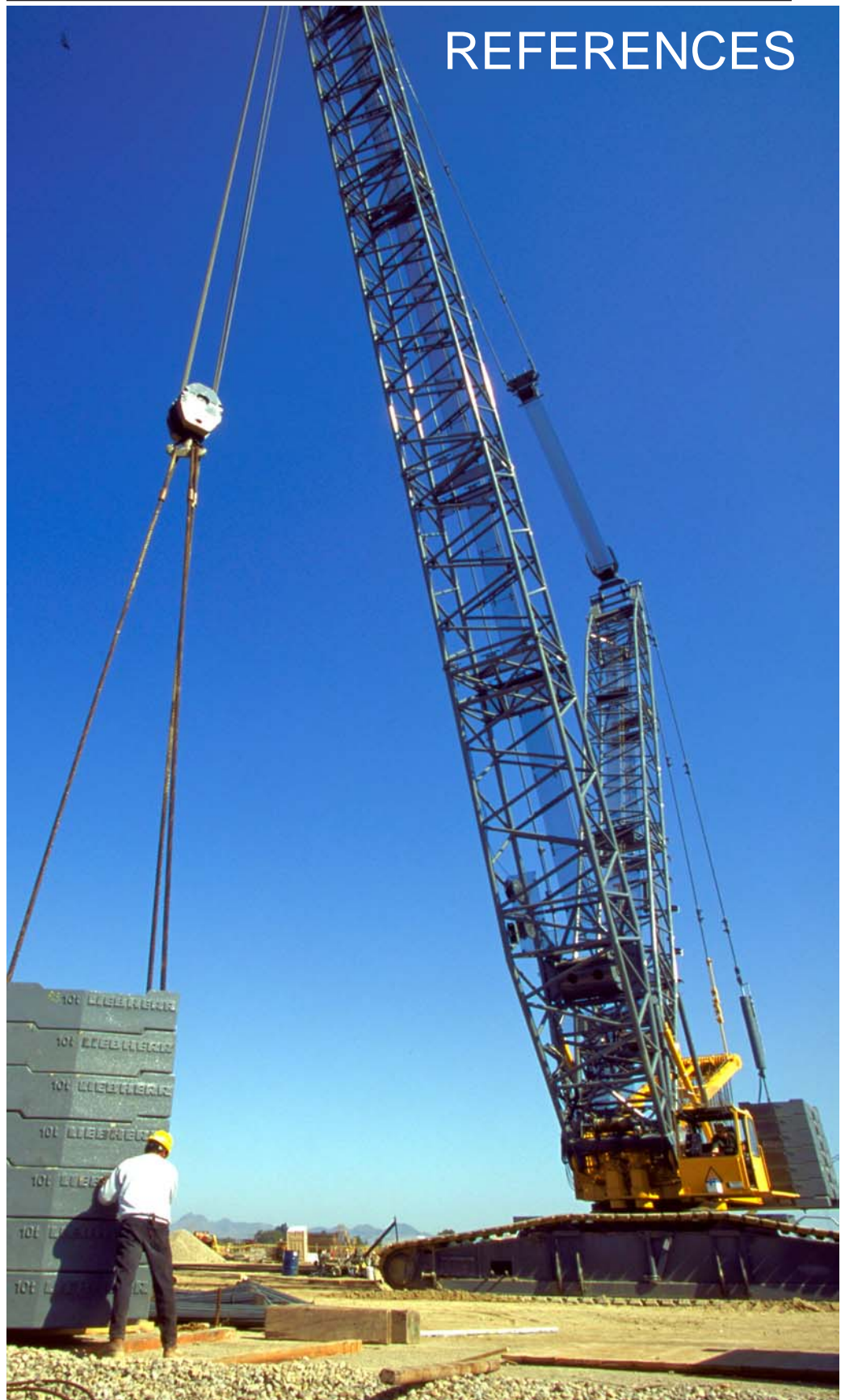

11. References

- AMERICAN HOIST & DERRICK COMPANY
145-T Heart Lake Road
Brampton, Ontario, Canada LGW 3K3

(416) 451-9261

(Cranes, Derricks, Hoists)
- AMERICAN PECCO CORPORATION
(See Morrow Crane)
- BIGGE CRANE AND RIGGING
10700 Bigge St.
San Leandro, CA 94577

(510)-638-8100

(Union wire rope sling handbook)
- BOB'S RIGGING & CRANE HANDBOOK
Bob De Benedictis, Inc.
6410 South Atlantic Avenue
New Smyrna Beach, Florida 32169

(904) 423-7759
FAX: (904) 423-7573
- BRODERICK & BASCOM ROPE COMPANY
Route 3
Oak Grove Industrial Park
P.O. Box 844
Sedalia, Missouri 65302-0844

(816) 827-3131

(Yellow strand wire rope slings)
(Rigger's Handbook by Broderick and Bascom)

- CF&I STEEL CORPORATION
P. O. Box 1920
Denver, Colorado 80201

DISTRICT OFFICE - 4067 Watts Street
Emeryville, California 94608

(Roebbling wire rope) Wire Rope Handbook - Publication A-960

- CLARKE EQUIPMENT COMPANY
Lima Division
100-T
North Michigan Street
P.O. Box 7008
South Bend, Indiana 46634

(219) 239-0100

(Lima truck and crawler cranes)

- CONSTRUCTION SAFETY ASSOCIATION OF ONTARIO
74 Victoria Street
Toronto, Ontario, Canada M5C 2A5

(Crane Handbook and Rigging Manual)

- Cranes and Derricks
by Howard I. Shapiro, P.E.
McGraw-Hill Book Company

- CRANE MANUFACTURERS OF AMERICA (CMAA)
8720 Red Oak Blvd.
Charlotte, NC 28271

(704)-522-8664

- Cranes and Derricks
by Howard I. Shapiro
published by McGraw-Hill
New York

- CRANWORKS MAGAZINE
10229 E. Independence Ave.
Independence, Missouri 64053

- THE CROSBY GROUP
A Division of AM Hoist
P.O. Box 3128
Tulsa, Oklahoma 74101

(918) 834-4611

FAX: (918) 832-0940

(Crosby Engineering Journal No. EJ-76)

(Crosby fitting, Lebus McKissick blocks, Western sheaves, National sleeves and presses - Catalog No. 950-7 and 950-6 Section IA)

- THE DUFF-NORTON HIGH PRESSURE HYDRAULICS HANDBOOK
P.O. Box 7010
Charlotte, North Carolina 28241

(704) 588-0510

- ENERPAC
13000 W. Silver Spring Road
Butler, Wisconsin 53007

(414)-781-6600

(hydraulic jacking equipment)

- EKCO INSTRUMENTS LIMITED
Priory Crescent
Southend-on-Sea, Essex
England SS26PS

Telephone: Southend-on-Sea 330851

(Ekco load guard indicator systems)

- ESCO CORPORATION
144-146 West 18th Street
New York, New York 10011

(212) 242-2500

(Swaged sleeves and sockets, rigging attachments, and swaging press)

- FMC CORPORATION
200 E. Randolph Drive
Chicago, IL 60601

(800) 621-4500

- GLG SYSTEMS, INC.
11152 Condor Avenue
Fountain Valley, California 92708

(714) 549-4777

(Load indicating units)

- GROVE MANUFACTURING COMPANY
Division of Walter Kidde & Company, Inc.
Shady Grove, Pennsylvania 17256

(717) 597-8121

(Grove hydraulic telescoping boom cranes)

- HANDBOOK FOR RIGGERS
by W. G. (Bill) Newberry
Printed in Canada

- HANDBOOK OF RIGGING FOR CONSTRUCTION AND INDUSTRIAL
OPERATIONS
by W. E. Rossnagel - P.E.
Fourth Edition - McGraw-Hill

- HARNISCHFENGER INTERNATIONAL CORP, S.A.
P. O. Box 554
Milwaukee, Wisconsin 53201

(P&H Cranes)

- HEEDE INTERNATIONAL, INC.
One Greenwich Plaza
Greenwich, Connecticut 06830

(203) 661-9040

(Hydraulic lift climbers)

- HILMAN, INC.
2604 Atlantic Ave.
Wall, New Jersey 07719

(201) 449-9296

- I & I SLING, INC.
2626 Market Street
P.O. Box 2068
Aston, Pennsylvania 19014

(610) 485-8500 (Mark Coyle)

FAX: (610) 494-5835

(Kevlar Slings and Slingmax Riggers Handbook)

- J & R ENGINEERING
538 Oakland Avenue
P.O. Box 447
Mukwonago, Wisconsin 53149

(262) 363-9660

FAX: (262) 363-9620

(Hydraulic Gantrys and Associated Equipment)

- JOHN CHATTILLON & SONS
83-30 Kew Gardens Road
Kew Gardens, New York 11415

(212) 847-5000

(Chatillon dynamometers)

- KOEHRING
Lorain Division
Chattanooga, Tennessee 37405

(Crane Application Handbook by Lorain Printing, Lorain, Ohio)

- LIEBHERR CRANE/SCHILLER INT.
101 Eaton Street
Hampton, VA 23669

(757) 727-0700

- LIFTECH
366 Grand Ave.
Oakland, CA 94610

(510)-832-5606

(specialty rigging design)

- LIFT SYSTEMS
205-42ST Street
Moline, IL 61265

(309)-765-9842

(hydraulic gantries)

- LIFTEX SLINGS, INC.
204-T Railroad Drive
Northampton Industrial Park
Ivyland, Pennsylvania 18974

(215) 322-9095

(Nylon slings)
- LIFTING & TRANSPORTATION INTERNATIONAL MAGAZINE
9609 Gayton Road, Suite 100
Richmond, Virginia 23233-4904
- LITTON SYSTEMS, INC.
300-T Marcus Blvd.
Deer Park, New York 11729

(516) 586-5100

(Compulift crane warning systems)
- LUCKER MANUFACTURING COMPANY
444 South Henderson Road
King of Prussia, Pennsylvania 19406

(215) 337-0444

(Cable grip equipment)
- MACWHYTE WIRE ROPE COMPANY
2936 Fourteenth Avenue
Kenosha, Wisconsin 53140

(414) 654-5381

(Wire Rope Catalog G-17 - Sling Catalog S-9)

- MANITOWOC ENGINEERING COMPANY

500 S. 16th Street
Manitowoc, Wisconsin 54220

(414) 684-6621

(Cranes and hoists)

- MARINO CRANE SERVICE

25 Mill Street
Middletown, CT 06457

(860) 347-0827

- MARTIN-DECKER COMPANY

1200-T Cypress Creek Road
Cedar Park, Texas 78613

(Martin Decker load indicating systems)

- MORROW CRANE

3218 Pringle Rd. S.E.
Salem, OR 97302

(503)-585-5721

(Liebherr and Pecco tower cranes)

- PADGETT INC.

901 E. Fourth St.
New Albany, IN 47150

(812)-945-1299

(specialty rigging steel fabrication)

- PEERLESS DIVISION
Royal Industries
18205 S. W. Boones Ferry Road
P. O. Box 447
Tualatin, Oregon 97062

(Trailers)
- PIASECKI AIRCRAFT CORPORATION
Island Avenue, International Airport
Philadelphia, Pennsylvania 19153

(215) 365-2222

(Heli-Stat Heavy Vertical Air Lift Systems)
- PREWITT ASSOCIATES 1634 N. Broadway
Lexington, Kentucky 40505

(Prewitt strain gages)
- RELIANCE CRANE AND RIGGING
2500 N. 24th Ave.
Phoenix, AZ 85009

(602)-258-3718
- RIGGER'S BIBLE
(Handbook of Heavy Rigging by Robert P. Leach)
- RIGGER'S BIBLE
P.O. Box 2402 - National Station Springfield, Missouri
- Rigging for Commercial Construction
Reston Publishing, Inc.
A Prentice-Hall Company
Reston, Virginia 22090

- **RON 2000 TENSION LOAD METER**
Yudan Weighing Systems
1095 South Shore Drive
Holland, Michigan 49423

(800) 922-8020

- **SSP CONSTRUCTION EQUIPMENT, INC.**
P.O. Box 2038
1100 East Second Street
Pomona, California 91766

(714) 623-6184

(Miller blocks, swivels and crane accessories)

- **SHEAVE MASTER, INC.**
P.O. Box 736
Addison, Texas 75001

(214) 241-9191

(Sheave Master load and radius indicating systems)

- **SIKORSKY AIRCRAFT**
6900 Main Street
Stratford, Connecticut 06601

(203) 386-4000

(Heavy lift helicopters)

- **THE SKOOKUM COMPANY, INC.**
P. O. Box 03099
8524 N. Crawford Street
Portland, Oregon 97203

(503) 286-3627

(Block and rigging equipment) Catalog No. SC76

- U.S. STEEL SUPPLY
Division of United States Steel
P.O. Box 368
San Francisco, California 94101

(415) 621-4988

or P.O. Box 2489
Houston, Texas 77001

(713) 672-8351

(Wire rope manufacturers)
(Tiger Brand wire rope and slings)
(Tiger Brand Wire Rope Engineering Handbook)
- VALLEY FORGE STEEL
10702 Bigge St.
San Leandro, CA 94577

(510)-638-2929

(specialty and rigging steel fabrication)
- VAN SEUMEREN, U.K.
Coulson House
15 Front St. West
Bedlington
Northumberland
NE22 5TZ

011-44-01670-820-881
- VEMCO INDUSTRIES, INC.
305 South Acacia Street
San Dimas, CA 90599-6745

(909) 599-6745

(Vibra Tension load indicators)

- VERSABAR, INC.
1111 Engineers Rd.
Belle Chase, LA 70037

(504)-392-3200
FAX: (504)-392-3211

- WEAR FLEX SLINGS
Division MHS Limited
6616 W. Irving Park Road
Chicago, Illinois 60634

(312) 736-3333

(Nylon slings)

- WEIGHLOAD, INC.
1049 South Mahaning Avenue
Alliance, Ohio 44601

(216) 823-7800

(Load indicators, boom angle indicators)

- WILLY SCHEUERLE
Fahrzeugfabrik
D 7114 Pfederbach

Telephone: Oehringen 07941/7031

(Hydraulic platform trailers)

- WIRE ROPE INDUSTRIES OF CANADA LIMITED
1611 40th Street
Calgary, Alberta

(403) 265-1541

(Blue Strand Wire Rope Catalogue)

- Wire Rope Sling Users Manual

Wire Rope Technical Board
P.O. Box 849
Stevensville, Maryland 21666

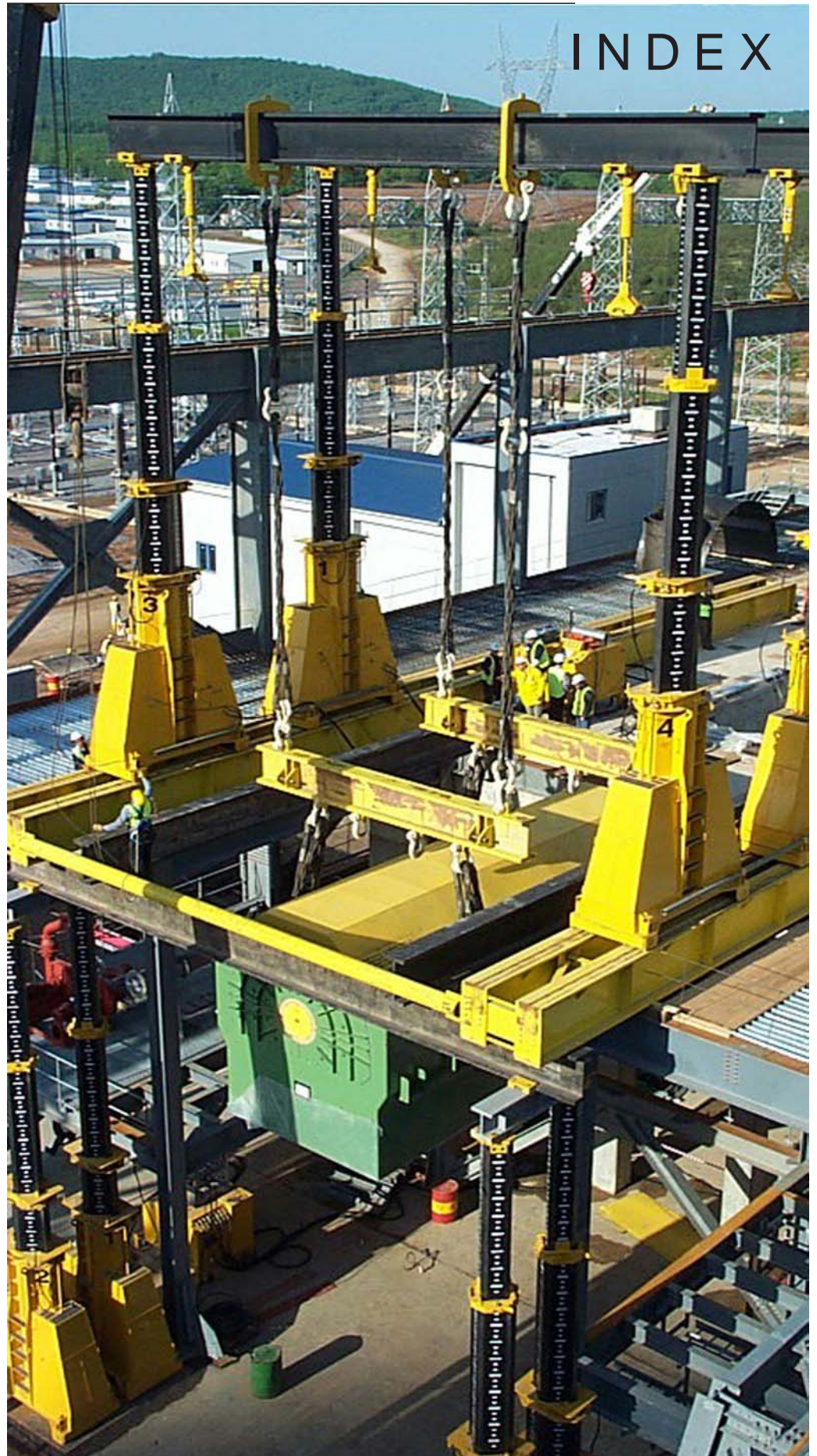

Index

A

all terrain carrier 3-6
All terrain crane 3-14, 3-23
All terrain cranes (AT) 3-13
AMERICAN NATIONAL 1-12
anchor bolt 3-64
ANSI 1-11, 1-12, 1-13, 1-14, 1-15, 1-17, 1-19
AT 3-13, 3-14
AT Crane 3-16
Axle 7-8, 7-12

B

Bechtel 1-3, 1-7, 1-9, 3-57
boom clearance 3-7
boom hoist 3-18, 4-22
Braided 4-44

C

Calculations 1-9
Carrier 1-14, 3-5, 3-39, 3-45, 3-48
carrier 3-3, 3-4, 3-5, 3-6, 3-11, 3-13, 3-16, 3-18, 3-36, 3-50
chain 1-9, 1-10, 1-13
chart 1-9, 1-10, 1-15, 1-17
Choker 4-11, 4-14, 4-15
CLEARANCE 1-12
Clearance 1-12
clearance 1-9, 1-11, 3-7, 3-12, 3-14, 3-16, 7-4
computer 3-6, 3-13
counterweight 1-15
Crawler Base 3-6
crawler base 3-5, 3-24, 3-27
Crawler Crane 3-21, 3-26
Crawler crane 3-20, 3-33, 3-38
crawler crane 3-20, 3-22, 3-24, 3-27, 3-30, 3-42, 3-44, 3-54, 7-14
Crawler Mounted 3-20
Crawler mounted 3-20
crawler mounted 3-3, 3-6, 3-18, 3-20, 3-27
cribbing 1-9, 1-14, 3-52

D

deflection 3-4, 3-37
Double Acting 6-61
Drum 1-13, 4-19, 4-20, 4-21, 4-22, 4-23, 6-81
drum 1-10, 4-9, 4-19, 4-20, 4-21, 4-22, 4-24, 4-28, 4-29
dynamic load 3-35, 3-37

E

earthquake 3-57
electric power 1-15, 1-16
ENGINEER 1-3
Engineer 1-7, 1-8, 1-9, 1-13
engineer 1-10
Eye Bolt 4-45

F

fiber 1-13
Field Engineer 1-7, 1-8, 1-9
Fleet 4-24, 4-25
fleet 4-24, 4-26, 4-37, 7-3
Footing 3-59, 3-61, 3-62
footing 3-59, 3-60, 3-61, 3-62, 3-64
Friction 4-34, 4-41
friction 4-34, 4-38, 4-39, 4-40, 4-41

G

Gallows 6-73
Gantry Crane 1-12, 1-13
gantry crane 3-3
Guy Derrick 3-10
Guy derrick 3-10
guy derrick 3-9, 3-10

H

Hand signals 1-18
hand signals 1-10, 1-13, 1-18
Heavy Haul 1-7, 6-3, 7-5, 7-7, 7-9, 7-11, 7-13, 7-15
Heavy haul 6-3
heavy haul 1-7
Hitches 4-5, 4-7, 4-9, 4-11, 4-13, 4-15, 4-17
Hoist 1-10, 1-13, 1-14, 4-19, 4-47
hoist 1-10, 1-13, 1-14, 1-17, 3-3, 3-5, 3-18, 3-30, 3-35, 3-37, 3-41, 4-19, 4-20, 4-22, 4-29, 4-31, 4-36, 4-42
Hoist drum 4-19
hoist drum 4-19, 4-20

Hook 1-14
Hooks 1-13
hooks 1-9, 1-10, 1-13
hydraulic telescopic 3-11

J

Jacks 1-12, 6-61, 6-63
jacks 1-10, 1-12
Jib 3-7, 3-8, 3-39
jib 1-17, 3-4, 3-7, 3-11, 3-14, 3-16, 3-18, 3-20, 3-22, 3-23, 3-24, 3-37, 3-39, 3-41, 3-48, 3-55, 3-57

K

Kevlar 4-17
KMAG 7-10

L

Lattice 3-18, 3-19, 3-20, 3-21, 3-22, 3-38
lattice 3-3, 3-4, 3-6, 3-7, 3-8, 3-9, 3-13, 3-14, 3-18, 3-20, 3-21, 3-24, 3-39
layout 1-9
LOAD RATING 3-31, 3-33, 3-35, 3-37, 3-39
load rating 3-30, 3-31
Locomotive 1-13
Luffing 3-8, 3-16
luffing 3-4, 3-7, 3-14, 3-22, 3-23, 3-24, 3-31
lug 4-45

M

MAST 1-12
Mast 1-12
mast 3-9, 3-10, 3-24, 3-27, 3-39, 3-58, 3-61, 3-62
MOBILE CRANE 3-31, 3-33, 3-35, 3-37, 3-39, 3-41
Mobile Crane 1-16
Mobile crane 1-14, 3-3, 3-30
mobile crane 1-13, 3-3, 3-5, 3-6, 3-22, 3-30, 3-36, 3-37
Multi 1-16, 7-3, 7-8
multi 1-16, 4-31, 7-3, 7-12, 7-13

N

Nylon Web 4-16

O

obstruction 3-7, 3-12, 3-14, 3-16
OSHA 1-9, 1-12, 4-9, 4-14
outriggers 1-15

overturning 3-62

P

Personnel 1-14

personnel 1-8, 1-10, 1-13, 1-14, 1-15, 1-16

Polyester 4-18

polyester 1-13

R

rated load 3-30, 3-31

RIGGING ENGINEER 1-3

Rigging Engineer 1-7, 1-8, 1-9, 1-13

rigging engineer 1-10

RIGGING PLAN 1-3, 1

Rigging Plan 3

Rigging plan 1-8

rigging plan 1-7, 1-8, 1-11

Rigging Superintendent 1-7

Ringer 3-25

Roller 6-72

rollers 6-65

Rope 4-6

rope 1-9, 1-10, 1-13, 1-17

Rough Terrain 1-14, 3-11, 3-12

rough terrain 3-6, 3-11, 3-36

RT 3-6, 3-13

rubber 1-10

S

SAFETY 1-7, 1-9, 1-11, 1-12, 1-13, 1-15, 1-17, 1-19

Safety 1-9

safety 1-3, 1-9, 1-10, 1-11, 1-12, 1-13, 1-14, 1-15

Schnabel 7-14

seismic 3-55, 3-57

Service Load 6-25, 6-26, 6-27

Shackle 4-44

shackle 1-9, 4-45

shackles 1-9, 1-10

Sheave 4-35, 4-41, 6-12

Single Acting 6-61

SITE MANAGER 1-3

Site Manager 1-7

Sling 4-3, 4-6, 4-16, 4-17, 4-18

sling 1-9

Slings 1-13, 4-5, 4-7, 4-9, 4-11, 4-13, 4-15, 4-17, 4-19, 4-21, 4-23, 4-25, 4-44

slings 1-9, 1-10, 1-13

soil bearing 3-55

Soil Bearing Capacity 3-61
Soil bearing capacity 3-61
soil bearing capacity 3-52, 3-53, 3-54, 3-61, 3-62
Stability triangle 7-6
static loading 3-37
Statics 7-15
statics 7-4, 7-12
Stiffleg 3-9
stiffleg 3-9, 3-10
Stiffleg derrick 3-9
stiffleg derrick 3-9, 3-10
Strand 6-77
Strand Lift 6-77
Synthetic 4-3, 4-44
synthetic 1-13

T

Telescopic boom 3-4, 3-12, 3-14, 3-16, 3-20
telescopic boom 3-3, 3-4, 3-6, 3-11, 3-12, 3-13, 3-14, 3-16, 3-18, 3-39
Tilt 7-17
TIRE 6-25
Tower Crane 1-12, 3-7, 3-8, 3-9, 3-55, 3-57, 3-59, 3-61, 3-63, 3-65
Tower crane 3-3, 3-8, 3-55
tower crane 3-3, 3-4, 3-7, 3-8, 3-14, 3-22, 3-23, 3-55, 3-57, 3-58, 3-61
tractive effort 6-7
Tractor 6-20, 6-21, 6-22, 6-23, 6-24
TRANSIT 1-12
Transit 1-12
Transporter 7-8, 7-10, 7-12, 7-14, 7-19

U

Upperworks 3-5, 3-48
upperworks 3-5, 3-7, 3-18, 3-24, 3-48, 3-49, 3-50

W

Wind 3-56, 3-57
wind 3-30, 3-31, 3-35, 3-37, 3-55, 3-57, 3-61, 4-19