



Mining & Quarrying
OCCUPATIONAL HEALTH &
SAFETY COMMITTEE

Conveyor Safety Guide

Promoting Work Health and Safety in the Workplace

The South Australian Mining and Quarrying Occupational Health and Safety Committee

Promoting Work Health and Safety in the Workplace

This workplace industry safety resource is developed and fully funded by the Mining and Quarrying Occupational Health and Safety Committee (MAQOHSC).

Disclaimer

IMPORTANT: The information in this guide is of a general nature, and should not be relied upon as individual professional advice. If necessary, legal advice should be obtained from a legal practitioner with expertise in the field of Work Health and Safety law (SA).

Although every effort has been made to ensure that the information in this guide is complete, current and accurate, the Mining and Quarrying Occupational Health and Safety Committee, any agent, author, contributor or the South Australian Government, does not guarantee that it is so, and the Committee accepts no responsibility for any loss, damage or personal injury that may result from the use of any material which is not complete, current and accurate.

Users should always verify historical material by making and relying upon their own separate inquiries prior to making any important decisions or taking any action on the basis of this information.

Creative Commons



This work is licenced under

Creative Commons Attribution – Non Commercial 4.0 International Licence.

The licence is available to view at <http://creativecommons.org/licenses/by-nc/4.0/>

This creative commons licence allows you to copy, communicate and or adapt our work for non-commercial purposes only, as long as you attribute the work to Mining and Quarrying Occupational Health and Safety Committee and abide by all the other licence terms therein.

ISBN 978-1-925361-24-7

Contact information

Mining and Quarrying Occupational Health and Safety Committee (MAQOHSC)

World Park A Building

Level 4, 33 Richmond Road

Keswick SA 5035

Phone: (08) 8204 9842

Email: maqohsc@sa.gov.au

Website: www.maqohsc.sa.gov.au

Contents

1.	Introduction	2
2.	Definitions	2
3.	What legislation requires	4
4.	Provision of appropriate guarding	5
5.	Provision of emergency stop controls	6
5.1.	Pull wire requirements	6
5.2.	Location of pull wires	7
5.3.	Location of pull wires	8
6.	Main isolating device	9
7.	Remote isolating device	9
8.	Prestart warning system	10
9.	Marking of control devices	10
10.	Making your conveyor safe	11
11.	Physical guarding	11
12.	DESIGN AND CONSTRUCTION OF GUARDS	11
12.1.	General	11
12.2.	Materials	11
12.3.	Reach dimensions and guard placement	12
12.4.	Types of guards	12
12.4.1.	Fixed enclosure guard	12
12.4.2.	Fixed distance guards	14
12.4.3.	Nip guards	16
13.	PARTS REQUIRING GUARDING	19
13.1.	Shear Points and Nip Points	19
13.2.	Rotating parts	20
13.3.	Hoppers and chutes	20
13.4.	Loading, unloading and discharge points	20
13.5.	Guarding of openings in floors	20
14.	REMOVAL OF GUARDS	21
14.1.	General	21
14.2.	Inspection doors in fixed guards	21
14.3.	Removal of guards and opening of inspection doors	21
14.4.	Labelling of guards	22
15.	SAFE WORK PRACTICES	22
15.1.	General	22
15.2.	Information to be supplied and maintained	22
15.3.	Synopsis of plant	23
15.4.	Installation, commissioning and dismantling	23
16.	SAFE WORK PROCEDURES	24
16.1.	General	24
16.2.	Isolation procedure	24
16.3.	Operating procedures	24
16.4.	Maintenance procedures	24
17.	MAINTENANCE MANAGEMENT	24
17.1.	General	24
18.	Training	25
	FURTHER ASSISTANCE	26
	ADDITIONAL INFORMATION	26
	REFERENCES	26

Conveyor Safety Guide

1. Introduction

As a large portion of the mining and quarrying process is the moving of product, most mines and quarries inevitably have some form of conveying systems as conveyors are an efficient form of moving material. To move large amounts of material requires a lot of energy, and it is this energy which makes conveyors one of the most hazardous items of plant in a mine or quarry.

Typically workers do not spend large amounts of time around conveyors. Most of the work conducted around conveyors involves inspections, maintenance and housekeeping. Generally this work occurs when the conveyor is not in operation and is isolated.

As a result, incidents around conveyors are not common. However, due to the energy associated with conveyors, when an incident occurs the consequences are likely to be serious or even catastrophic.

There are many hazards that exist around conveyors (for example: dust, noise, falling objects, heavy equipment and rotating / moving parts). This guide will focus on the risk of entanglement with moving parts. It will explain what your legislative obligations are and provide examples on how you can ensure your plant is safe.

2. Definitions

Automatic stop control - Includes controls which automatically stop conveyor systems such as over dimensional load, tension mechanism, over travel and temperature limit controls.

BMH belt conveyor - A conveyor using a moving belt for conveying bulk materials.

Bulk material - Solid particulate materials, such as ores, coal, grains, wood-chips, sand, gravel and stone in bulk form. It also applies to the handling of mixed wastes

Competent person - A person who has, through a combination of training, education and experience, acquired knowledge and skills enabling that person to perform correctly a specified task.

Conveyor - Apparatus or equipment operated by any power other than manual, by which loads are raised, lowered or transported or are capable of being raised, lowered, transported or continuously driven by:

- an endless belt, rope or chain or other similar means;
- buckets, trays or other containers or fittings moved by an endless belt, rope, chain or other similar means;
- a rotating screw;
- a vibrating or walking beam; or
- rollers.

This includes the supporting structure and auxiliary equipment used in connection with the conveyor.

Conveyor system - An installation comprising one conveyor, or multiple conveyors whose control is integrated.

Danger zone - Any zone in or around a conveyor or conveyor system in which a person is subject to a risk to health or safety.

Emergency stop - Manually actuated control device used to initiate an emergency stop function which is intended to -

- Avert arising hazards or to reduce existing hazards to persons, damage to machinery or to work in progress; and
- Be initiated by a single human action.

Energy isolating device - Any device that physically prevents the transmission or release of energy. These may include, but are not limited to, electrical isolators, disconnect switches, line valves and blocks.

Fail safe - The principal of failure to safety, which is any failure of the machinery, its associated safeguards, control circuits or its power supply that leaves the machinery in a safe condition.

Guard - Part of a conveyor system specifically used to provide protection by means of a physical barrier.

Interlocked guard - Guard associated with an interlocking device so that:

- The hazardous conveyor functions protected by the guard cannot operate until the guard is closed;
- If the guard is opened while hazardous conveyor functions are operating, a stop instruction is given; and
- When the guard is closed, the hazardous conveyor functions protected by the guard can operate, but the closure of the guard does not by itself initiate their operation.

Interlock - Mechanical, electrical or other types of device, the purpose of which is to prevent the operation of conveyor elements under specified conditions, generally as long as a guard is not closed.

Isolation and energy dissipation - A procedure which consists of all of the four following actions:

- Isolating (disconnecting or separating) the conveyor (or defined parts of the conveyor) from all energy sources that can cause harm;
- Locking (or otherwise securing) all the isolating units in the isolated position;
- Dissipating or, if this is not possible or practicable, restraining (containing) any stored energy which may give rise to a hazard; and
- Verifying that the actions taken according to Items (a), (b) and (c) above have produced the desired effect.

Mining – A system of obtaining and processing minerals or coal, including quarrying.

Nip point - The point at which a moving conveyor element meets a fixed or moving element, so that it is possible to nip, pinch, squeeze, entangle or entrap parts of the human body.

Permanently fixed guard - Permanently fixed physical barriers which are designed to be welded or otherwise incorporated into the body of the conveyor, or its components, so that access to the danger zone is not required during normal operation, maintenance or cleaning (e.g. gearbox covers and head chute covers).

Pull wire - A wire connected to a device, normally provided for emergency stop control which, when pulled, activates the device.

Readily removable guard - A removable guard with a limited number of fasteners allowing the guard to be removed quickly. These types of guards are typically designed for ease of removal for routine maintenance, cleaning or inspection activities.

Shear point - The point at which, or the line along which, a moving part meets or passes close enough to a stationary part or object, so that parts of the human body can be caught, trapped or pinched between them.

3. What legislation requires

Within South Australia the legislative requirements in relation to safe guarding of conveyors is detailed in;

- *Work Health and Safety Act 2012 (SA)*
- *Work Health and Safety Regulations 2012 (SA)*
- Code of Practice - Managing the risks of plant in the workplace
- AS 1755:2000 – Conveyors – Safety Requirements
- AS 4024.1:2014 - Safety of Machinery (series)

The *Work Health and Safety Act 2012 (SA)*, Division 2, 19 - Primary duty of care, states “ A person conducting a business or undertaking (PCBU) must ensure, so far as is reasonably practicable, the health and safety of workers engaged, or caused to be engaged by the person”.

Further to this Part 2, Division 3, 21 - Duty of persons conducting businesses or undertakings involving management or control of fixtures, fittings or plant at workplaces states, “The person with management or control of fixtures, fittings or plant at a workplace” (the PCBU) “must ensure, so far as is reasonably practicable, that the fixtures, fittings and plant are without risks to the health and safety of any person”.

The *Work Health and Safety Regulations 2012 (SA)*, Chapter 5, Part 1, Division 7, 208 - Guarding, states “If guarding is used, the person with management and control must ensure that if access to the area of plant requiring guarding is not necessary during operation, maintenance or cleaning, the guarding is a permanently fixed barrier. If access to the areas requiring guarding is necessary during operation, maintenance or cleaning, the guarding is an interlocked physical barrier. If it is not reasonably practicable to use a permanently fixed barrier or an interlocked physical barrier, the guarding is a physical barrier that can only be altered or removed using a tool, or if it is not reasonably practicable to use a permanently fixed barrier, an interlocked physical barrier or a physical barrier fixed in position, the guarding includes a presence-sensing safeguarding system”.

“Guarding must be of solid construction and securely mounted so as to resist impact or shock and prevent by-passing or disabling of the guard. Not create a risk in itself (for example it must not obstruct operator visibility, weaken the plant, cause discomfort to operators or introduce new hazards such as pinch points, rough or sharp edges) be properly maintained. Control any risk from potential broken or ejected parts and work pieces. Allow for servicing, maintenance and repair to be undertaken with relative ease, and if guarding is removed the plant cannot be restarted unless the guarding is replaced”.

Code of Practice - Managing the risks of plant in the workplace

The Code provides practical guidance on how to manage health and safety risks of plant once it is in the workplace, from plant installation, commissioning and use through to decommissioning and dismantling. It includes information about specific control measures required under the Work Health and Safety Regulations for plant generally. Other approved codes of practice on various types of plant may also be referenced.

AS 1755:2000 - Conveyors – Safety Requirements

Sets out the minimum safety requirements for the design, installation and guarding of conveyors and conveyor systems. It includes requirements for users and providers of inspection, maintenance, training and implementation of safe work practices for such equipment. Particular emphasis is given to operational safety and the protection afforded to operators, maintenance personnel or other persons who may be exposed to risks to health and safety associated with conveyors or conveyor systems.

AS 1755:2000 - Conveyors – Safety Requirements includes requirements for—

- a) Specific locations, such as hazardous areas, confined spaces and coal mines; and
- b) Specific types, such as belt conveyors and mobile or transportable conveyors.

4. Provision of appropriate guarding

AS 1755:2000 - Conveyors – Safety Requirements states that “Guards shall be designed and provided to prevent access to danger zones unless the danger zone is guarded by location or position. Guards shall be included in the design of the conveyor or conveyor system and shall not in themselves create a hazard. All guards shall be secured in position so that they cannot be removed without the use of tools unless an interlocking device is provided to automatically stop the conveyor in the event of the removal of the guard and guards shall be designed to prevent—

- a) persons reaching into the danger zone;
- b) clothes and hair or other body parts becoming caught;
- c) conveyed materials accidentally falling or being projected onto persons;
- d) the hazard from the failure of a component;
- e) inadvertent contact with a danger point on the conveyor; or
- f) inadvertent contact with hot or hazardous fluids from fluid couplings or torque converters.

5. Provision of emergency stop controls

AS 1755:2000 - *Conveyors – Safety Requirements* states that, Controls shall be provided to stop the conveyor or conveyor system in an emergency. These stop controls shall be of the manually operated, automatic lock-off manual reset type. The circuit in which emergency stopping controls are provided shall be designed fail safe and otherwise protected from faults that may defeat the operation of the facility. Emergency stop controls shall be capable of being operated with minimal effort without danger to the operator and shall be provided where the operating control is clearly visible and readily accessible even for inaccessible conveyors.

Emergency stop controls shall be provided as follows:

- a) For conveyors not greater than 2.5 m in length and located less than 2.5 m above the floor, walkway or platform, a single stop control at the middle of the conveyor.
- b) For conveyors greater than 2.5 m in length and located less than 2.5 m above the floor, walkway or platform, at the head, tail, drive and at intervals not exceeding 30 m along the length of the conveyor.
- c) For conveyors positioned more than 2.5 m from the floor, walkways or platforms, at accessible locations at intervals not exceeding 100 m along the length of the conveyor.
- d) At positions adjacent to the conveyor at which the conveyor can be started.
- e) At every permanent working station.

Note: Where a conveyor is used for “mining” it is a requirement that a pull wire system be installed on every belt conveyor.



Example of emergency stop control

5.1. Pull wire requirements

AS 1755:2000 - *Conveyors – Safety Requirements* states that Pull wires shall not be used as substitutes for guards. Where used as an emergency stop control a pull wire activated device shall comply with following requirements:

- a) Breaking, slackening or removal of the pull wire shall activate the device.
- b) Where electrical continuity is monitored in the pull wire—

- I. The slackening requirement of Item (a) need not apply; and
 - II. The conveyor shall stop in the event of the pull wire being broken or removed.
- c) The force required to operate the pull wire activated device shall not exceed 70 N when applied midway between supports and at right angles to the axis of a pull wire with less than 300 mm movement and 230 N along the axis of the wire.
 - d) The design and distance between pull wire supports shall be such that the wire moves freely when pulled and does not become disengaged from the support.

Note: A maximum spacing of 6 metres should apply.

- e) Materials used for pull wires shall be of adequate strength, be protected against environmental conditions and be suitable for handling without the need for additional protection being worn by operators.

Note: Where more than one switch is used in a pull wire system, a visual indicator should be provided to indicate which switch has been activated.

- f) The switch shall be activated when the pull wire is pulled in any direction. (see figure 1)

Note: Pull wires are not an alternative to guarding.

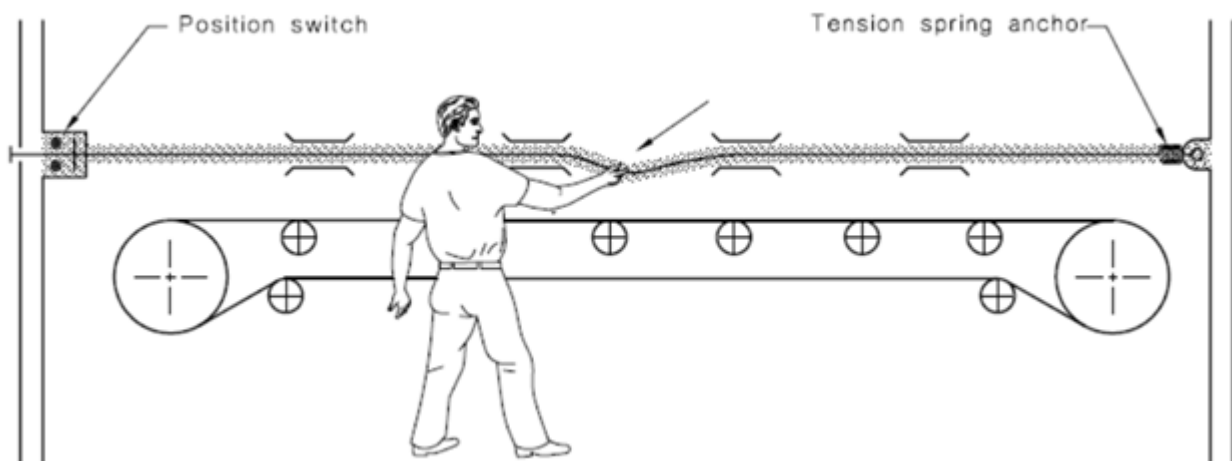

(Figure 1)

5.2. Location of pull wires

Pull wires should be located in such a manner that they are—

- a) clearly visible;
- b) readily accessible from all areas of access to the conveyor;
- c) located external to the vertical line of any nip or shear point and no further than 1 m from the nip or shear points;
- d) at least 900 mm above the access floor;
- e) generally not more than 1500 mm above the access floor;

- f) where all nip or shear points are greater than 1500 mm above the access floor the pull wire requirement of Item (e) may be raised provided the pull wire is lower than all nip or shear points; and

See Figure 2 for the preferred location of pull wires.

5.3. Location of pull wires

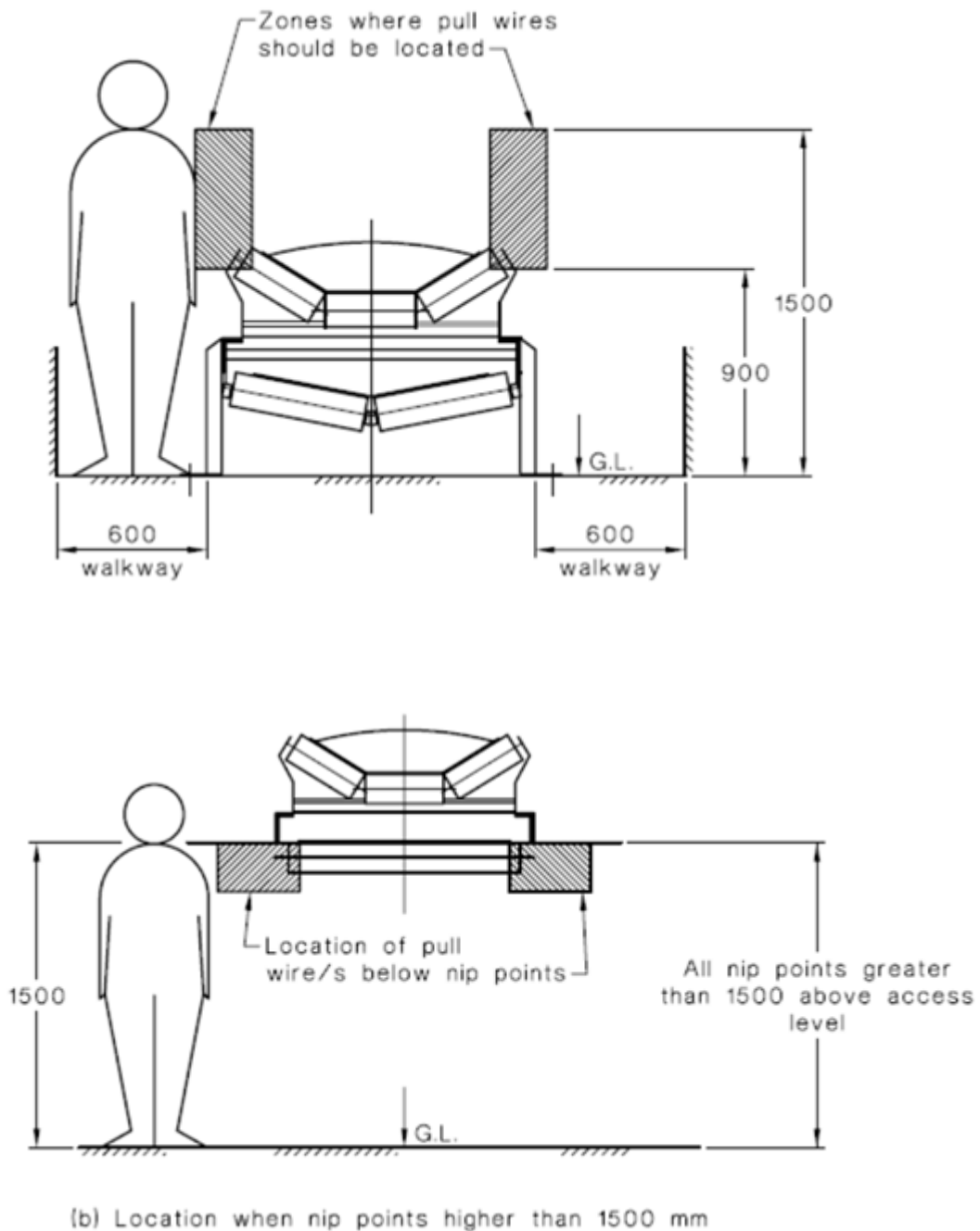

(Figure 2, dimensions in millimetres)

6. Main isolating device

An energy isolating device shall be installed to completely isolate the sources of drive energy from the conveyor or conveyor system. This device shall be capable of being locked in the isolating position, be of the manual reset type and be suitable for direct manual operation. The main isolating device shall not be capable of being locked in the 'on' position. Suitable facilities shall be provided to clearly indicate the operated state of the device.



(Examples of isolation devices)

7. Remote isolating device

Where it is required to isolate the conveyor remotely, an energy isolating device conforming with the following shall be provided for this purpose:

- a) The device shall be lockable in the isolated position and be of the manual reset type.
- b) The device shall isolate the source of energy from the drive system by either—
 - I. direct isolation of the energy source, or
 - II. indirect isolation of the energy source via a control system.
- c) Where indirect isolation of the energy source via a control system is used, the following shall apply:
 - I. The remote isolating device shall cause the isolation of the drive energy from the conveyor via at least two independent means to assure system integrity.
 - II. A system shall be provided to indicate at the remote isolation device, that the drive energy has been isolated.
 - III. A prestart warning system shall be provided.

8. Prestart warning system

Where an otherwise uncontrolled hazard may arise when a conveyor or conveyor system starts, an automatically operated prestart warning system shall alert people to the fact that the conveyor is commencing operation and a potential danger exists. The system shall be in the form of an appropriately timed visual or audible warning given prior to the conveyor starting. Where auditory or visual warnings are provided they shall not be a substitute for physical safeguards. Auditory or visual warnings shall be duplicated or overlapping and shall be monitored or inspected periodically to ensure adequate levels of safety.

9. Marking of control devices

Each manually operated stop, start or other function control shall be identified with markings, signs or labels in writing clearly indicating the purpose of the control. Notwithstanding the generality of this requirement, the following shall also apply:

- a) Emergency stop devices shall be indicated by a sign.
- b) Actuators of knock-off emergency stop devices shall be coloured red.
- c) Signs shall be provided at each end and every 30 m along a conveyor where a pull wire is used e.g. emergency stop.
- d) Signs shall be provided at the isolating devices provided which clearly indicate the function and purpose of the device.

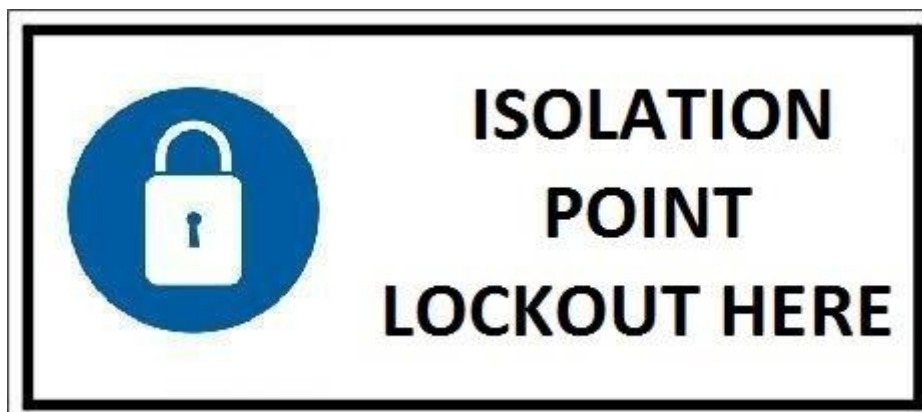

10. Making your conveyor safe

There is a combination of controls that will ensure the hazards associated with moving parts on conveyors are effectively controlled. They include physical guarding, isolators, procedures, training and signage.

11. Physical guarding

A physical barrier is the most effective means of protection from hazardous points on conveyors. It is a means of physically preventing access to hazardous areas, and is a legislative requirement.

12. DESIGN AND CONSTRUCTION OF GUARDS

12.1. General

Guards shall be designed and located in accordance with the requirements of *AS 4024.1-2014 Safety of Machinery*. Guards shall be designed to prevent—

- a) persons reaching into the danger zone;
- b) clothes and hair or other body parts becoming caught;
- c) conveyed materials accidentally falling or being projected onto persons;
- d) the hazard from the failure of a component;
- e) inadvertent contact with a danger point on the conveyor; or
- f) inadvertent contact with hot or hazardous fluids from fluid couplings or torque converters.

All guards shall be secured in position so that they cannot be removed without the use of tools unless an interlocking device is provided to automatically stop the conveyor in the event of the removal of the guard.

Guards should be designed so that it is not necessary to remove them for minor servicing (such as greasing) or inspection purposes.

12.2. Materials

Guards shall be made of solid material, mesh or equivalent construction. Sheet metal guards should not be less than 1.5 mm thick. Mesh guards should not be less than 1.5 mm wire gauge, or 3 mm wire gauge for 50 mm square mesh and above.

12.3. Reach dimensions and guard placement

Typically the safety distances are as follows:

- a) For square mesh with opening size up to and including 9 mm, guards shall be at least 25 mm from the nip or shear point.
- b) For square mesh with opening above 10 mm and up to 50 mm, guards shall be at least 200 mm from the nip or shear point.
- c) For fence type guards the maximum distance between the underside of the fence and the floor shall be 200 mm. The location of the nip or shear point may reduce this dimension.
- d) The minimum distance above the ground or walkway before guarding of nip points is not required is 2500 mm.

Further specific dimensions and formulas are available in appendix C of *AS 1755:2000 - Conveyors – Safety Requirements*.

12.4. Types of guards

Guards are normally provided in the form of—

- a) Fixed enclosure guards see Figure 3.1;
- b) Fixed distance guards see Figure 3.2; or
- c) Nip guards where shear hazards are not present see Figure 3.3.

12.4.1. Fixed enclosure guard

A fixed enclosure guard is a guard which, when in position, prevents access to a hazard or area by enclosure. It encloses the hazard to prevent access, so far as is practicable, consistent with the passage of the conveyor, materials and spillage.

Where an opening exists for the passage of the conveyor, the guard at the opening should extend for a minimum distance of 1000 mm from the hazard (see Figure 3.1). This distance shall be increased to 1150 mm when the pulley diameter is greater than 1000 mm. Where fixed enclosure guards cannot be used, fixed distance guards or nip guards shall be installed.

Guarding of idler sets where required should be provided on the approach side and should extend for 1000 mm from the nip point. On the out-running side the guard should extend for at least 1000 mm beyond the nip point (see Figure 3.4).



(example of fixed enclosure guard)

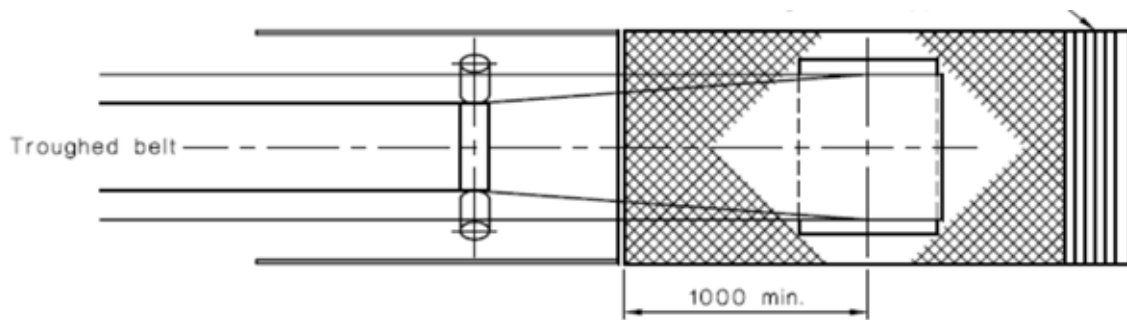

(a) Head pulley

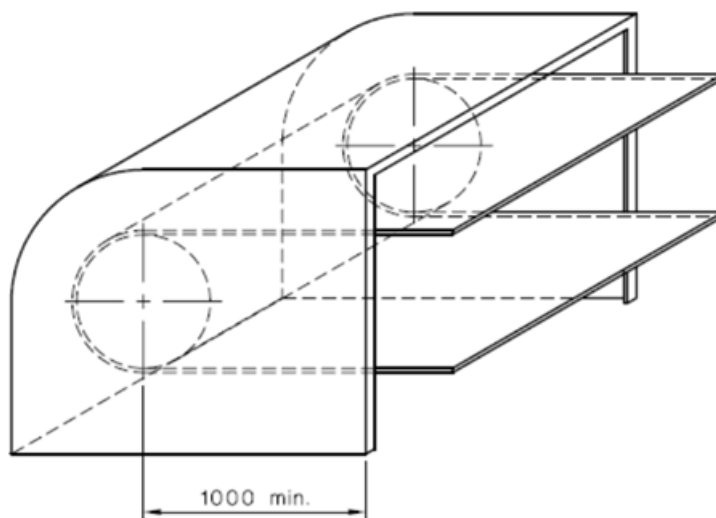

(b) Tail pulley

(Figure 3.1, dimensions in millimetres)

12.4.2. Fixed distance guards

A fixed distance guard does not completely enclose a hazard but reduces access by virtue of its physical dimensions and its distance from the hazard. It shall be designed and constructed with the object of preventing any part of the body from reaching a hazard. It may take the form of a fixed barrier or fence designed to such a height so as to prevent normal access to the danger zone, although climbing over this type of safeguard cannot be entirely eliminated.

(See Figure 3.2.)

Where fence type guards are used they shall ensure that—

- a) the access to any fenced area includes a system to automatically stop the conveyor before access is obtained to the danger zone; and
- b) a sign shall be provided at every access point through the fenced off area stating 'DANGER—Isolate drive before removing guard'.



(example of fixed distance guard and signage)

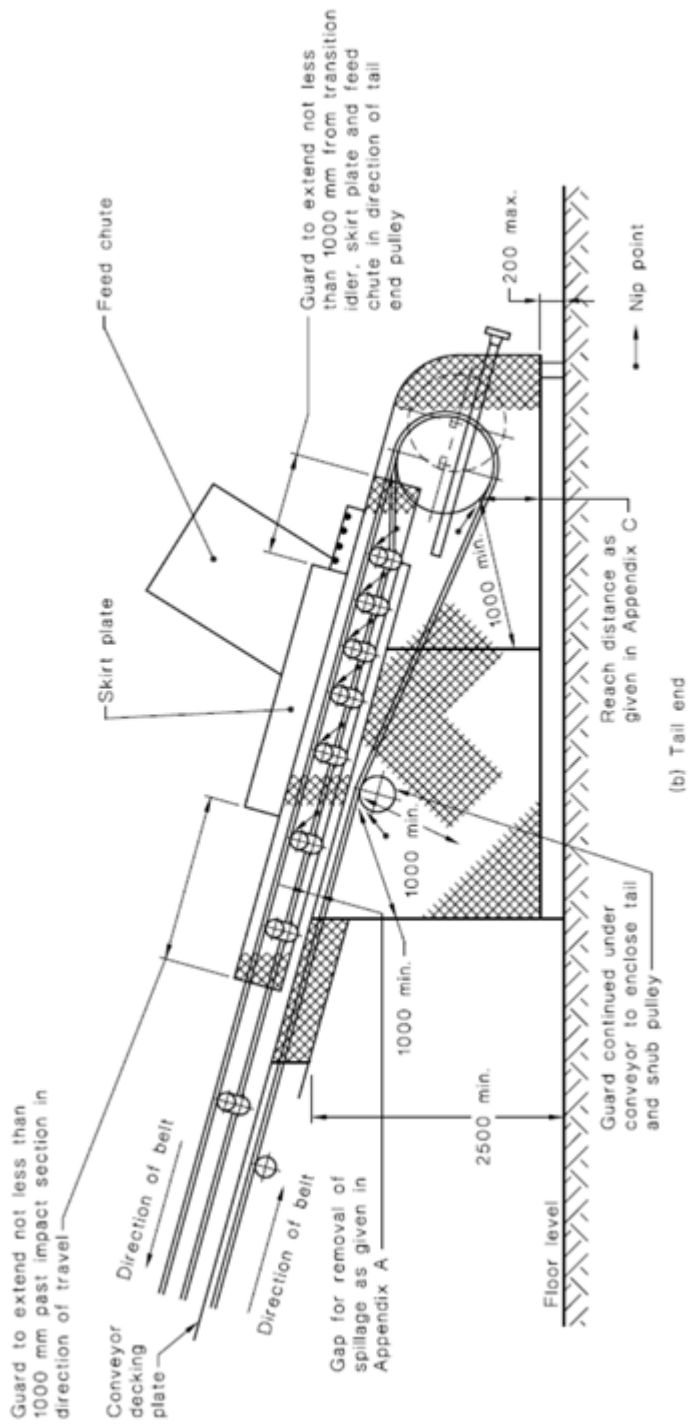

(Figure 3.2 dimensions in millimetres)

12.4.3. Nip guards

Nip guards shall extend for a minimum of 150 mm from the nip point and across the width of the belt for the full length of the idler or pulley and shall be closely fitted to follow the belt line and idler or pulley periphery approaching the nip, with gap not exceeding 4 mm. See Figure 3.3(a) and 3.3(b).

Note: *Nip guards may not provide adequate protection from injury due to entrapment of hair, skin or clothes.*

The principle of nip guards is shown in Figure 3.3(c). Examples of typical arrangements for nip guards at tail pulleys are shown in Figures 3.3).

Where nip guards of alternative designs are used, which do not provide adequate protection, they should be fitted in association with fixed enclosure guards or fixed distance guards.

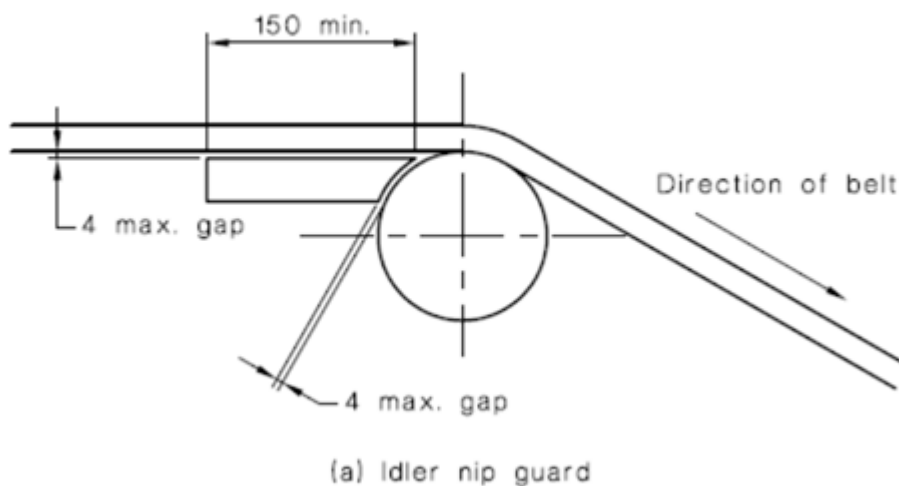

(Figure 3.3a, Dimensions in millimetres)

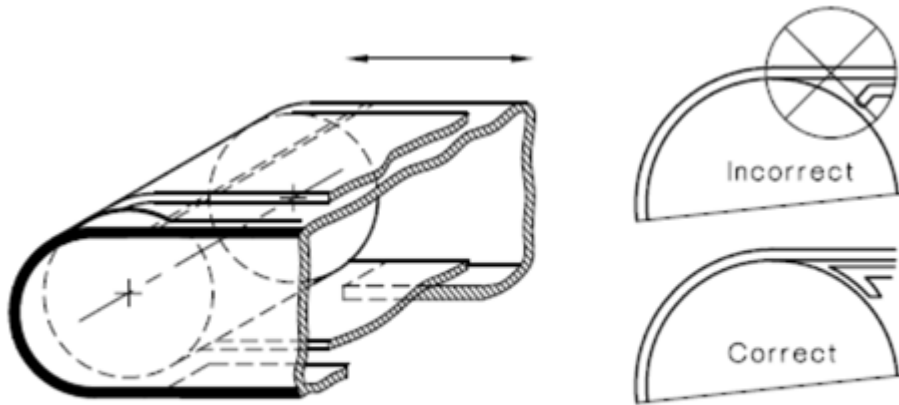

(b) Correct installation of nip guard

(Figure 3.3b)

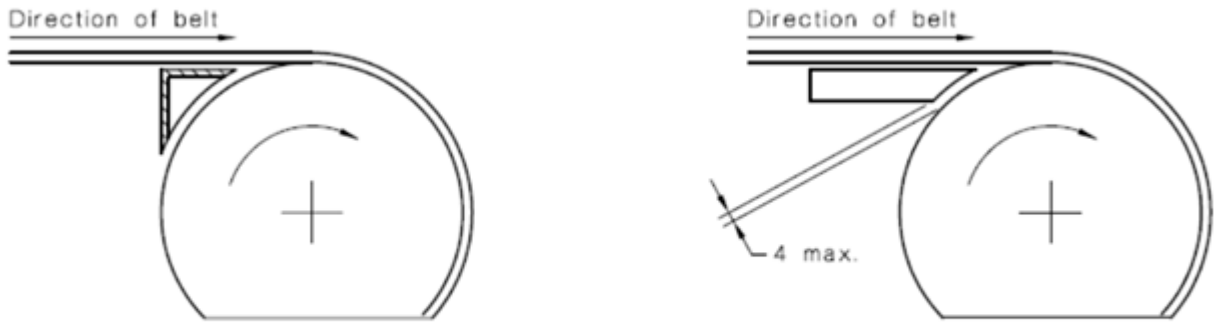

(c) Nip guard construction from rolled steel sections

(Figure 3.3c, Dimensions in millimetres)

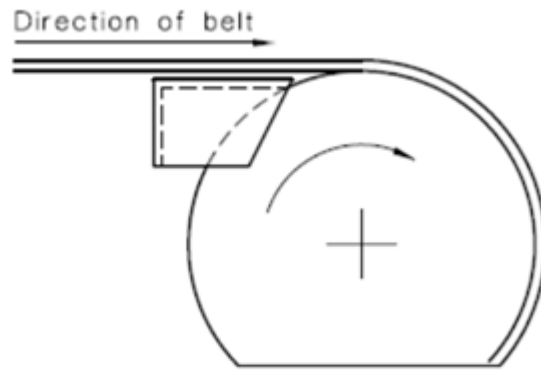

(d) Nip guard constructed from sheet metal

(Figure 3.3d)

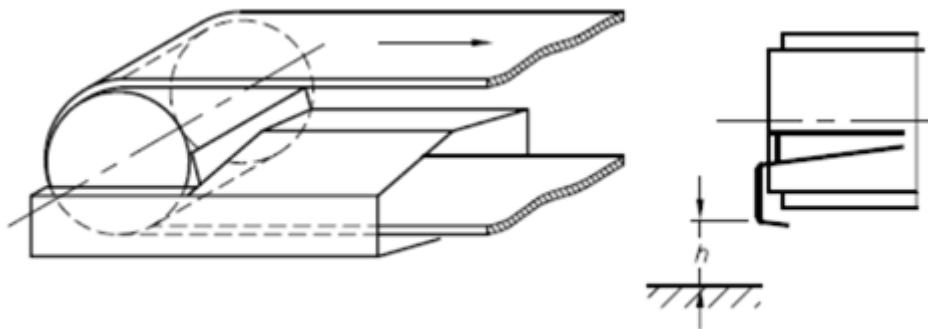

(e) Tail pulley nip guard

(Figure 3.3e)

13. PARTS REQUIRING GUARDING

13.1. Shear Points and Nip Points

Shear points and nip points in locations less than 2.5 m above any access floor, platform level, stored goods or materials shall comply with the following requirements:

- a) All shear and nip points shall be guarded. Shear and nip points are created where the gap between any moving part of the conveyor and any fixed equipment is greater than 4 mm and less than 120 mm.
- b) As an alternative, pop-out rollers or dead plates which, when operating, allow a minimum clearance of 120 mm to be maintained, may be provided. The force required to operate such devices shall not exceed 110 N.
- c) Where the surface of the moving part of the conveyor is provided with projections exceeding 6 mm in height, or where there is any type of attachment to the moving part, the minimum clearance of 120 mm shall be maintained between the highest point of the projection and the fixed equipment.

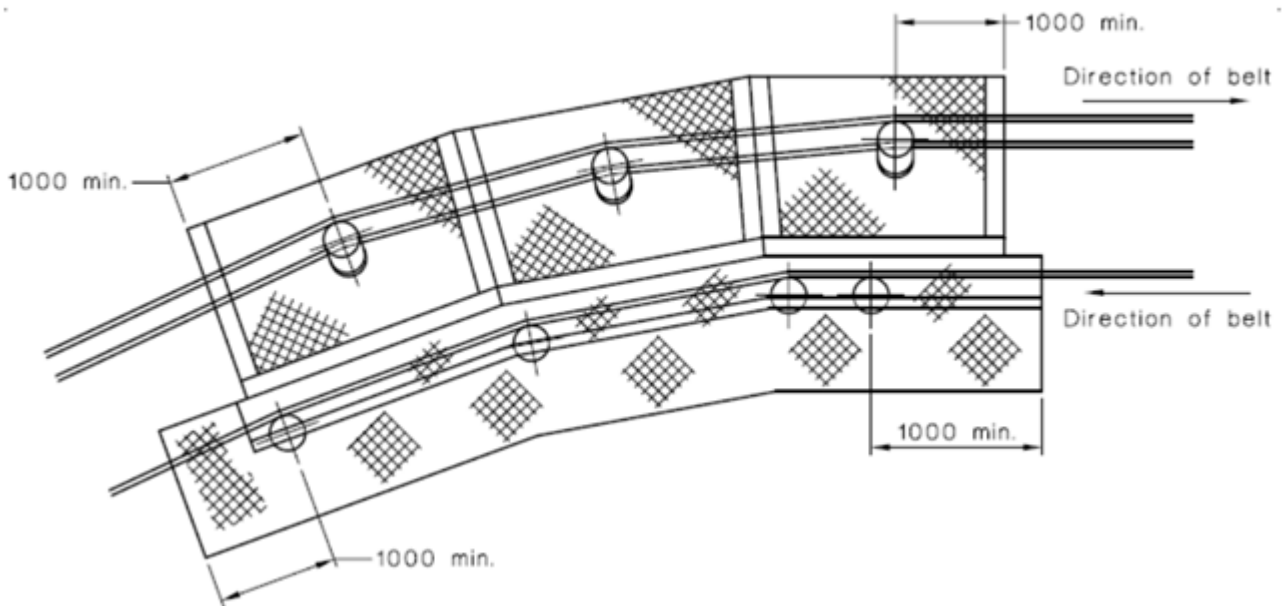

(Figure 3.4, Dimensions in millimetres)

13.2. Rotating parts

All exposed projections, gaps, shaft couplings or collars shall be guarded.

All fluid couplings fitted with a fusible plug or bursting discs shall be provided with suitable guards to control and contain discharge of fluid in the event of the plug fusing.

13.3. Hoppers and chutes

All openings to hoppers and chutes shall be suitably guarded where there is a risk of contacting dangerous parts or of personnel falling into the opening. Hoppers or chutes shall be provided with access or openings so that, as far as possible, any necessary cleaning or inspection may be carried out from outside the hopper or chute.

The sides of open hoppers or chutes shall be high enough to prevent material falling into working areas below. Open chutes should be provided with plates at the point where conveyors discharge into them to prevent materials from bouncing out of the chute.

Chute doors shall be located so that when open they do not create a hazard to personnel during normal operation of the plant.

Where a hazard exists from moving equipment behind inspection doors, the doors shall be lockable, or interlocked to the conveyor controls.

13.4. Loading, unloading and discharge points

Wherever a person has access to a loading, unloading, work station, transfer, or discharge point, guards in the form of guard-rails, fences, or close fitting guards shall be installed to prevent injury to that person.

13.5. Guarding of openings in floors

In locations where conveyors pass through a floor or where it is possible to step on moving parts of the conveyor or into the opening, guard railing and toe boards shall be provided in accordance with *AS 1657:2013 Fixed Platforms, Walkways, Stairways and Ladders*.

13.6. Falling materials

Where a hazard can be created by the material being conveyed falling into or being projected into an accessible area, then guarding shall be provided. Consideration should be given to the height, mass and speed of the material being conveyed. (See Figure 3.5.)

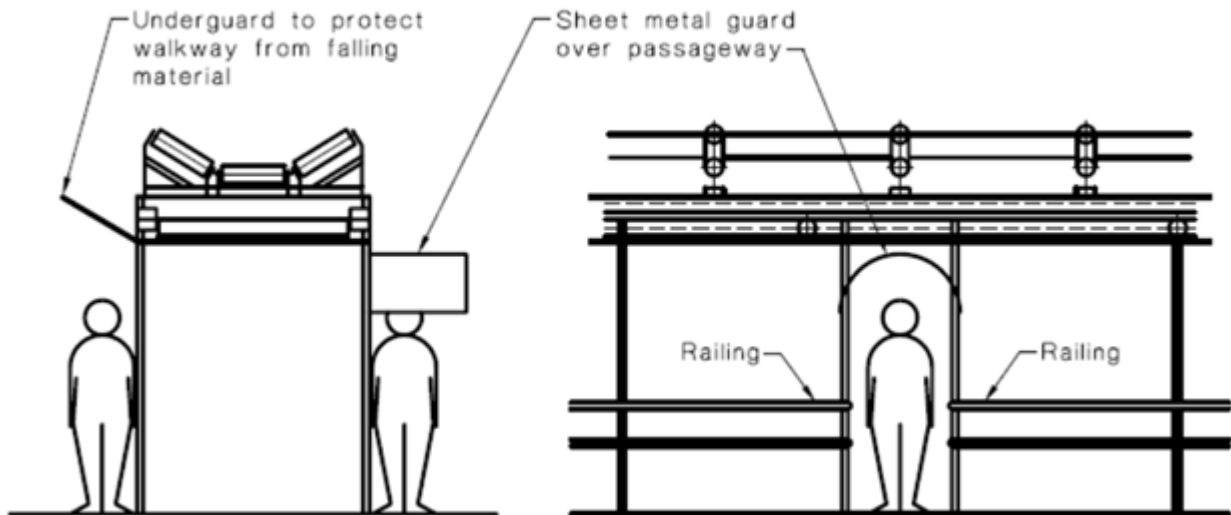

(Figure 3.5)

14. REMOVAL OF GUARDS

14.1. General

Where work requires the removal of guards, the conveyor shall be isolated.

14.2. Inspection doors in fixed guards

Where required for inspection, maintenance, cleaning, or operational purposes, inspection doors may be provided in a fixed guard. These openings shall not expose a person to the hazard being guarded.

14.3. Removal of guards and opening of inspection doors

Lifting handles or lugs shall be provided for the safe removal of guards and opening of inspection doors.

14.4. Labelling of guards

Removable guards shall be clearly labelled as follows, at intervals not greater than 10 m: 'DANGER—Isolate energy source before removing guard'.



15. SAFE WORK PRACTICES

15.1. General

In this section we will deal with safe work practices that need to be developed, implemented and maintained to ensure the safe installation, operation, maintenance and dismantling of conveyors and conveyor systems.

Whilst this section outlines the minimum requirements for safe work practices, a detailed risk assessment should be conducted to establish the safe work practices for the activities that are associated with the conveyor or conveyor systems

A comprehensive system of audits and checks to measure the effectiveness of the safe work practices and where these practices are found to be lacking appropriate controls need to be implemented.

15.2. Information to be supplied and maintained

Documentation needs to be provided, used and maintained for the operation of the conveyor or conveyor system. This documentation needs to include a synopsis of the plant, installation, commissioning, dismantling, operating and maintenance instructions. In each area where information is required, identification of potential hazards and their control needs to be included.

Where risk assessments are conducted, documented evidence of these assessments need to be recorded and maintained.

15.3. Synopsis of plant

The owner needs to maintain information regarding the synopsis of plant supplied by the manufacture and designer of the conveyor or system or system components.

The following information needs to be included in the synopsis of plant:

- a) Design capacities and criteria of the conveyor system and its components.
- b) General arrangement drawings including identification of system components.
- c) Schematic and logic drawings of power and control facilities.
- d) Parts identification including reorder details.
- e) Lubrication requirements.

15.4. Installation, commissioning and dismantling

The owner needs to maintain information regarding the installation, commissioning and dismantling of the conveyor or conveyor system including requirements of the manufacturer and designer.

The following information needs to be provided and maintained:

- a) Installation procedures.
- b) Dismantling, transport or removal procedure.
- c) Pre-operational servicing procedures including lubrication requirements.
- d) Procedures for the adjustment and setting of controls.
- e) Commissioning and testing procedures.
- f) Records of data collected during commissioning.
- g) A copy of each programmable logic controller program.
- h) Transport weights and identification of lift points.

15.5. Operating and maintenance instructions

The owner needs to maintain information regarding the operation and maintenance of the conveyor or conveyor system including requirements of the manufacturer and designer.

The following information needs to be provided and maintained:

- a) Loading and unloading instructions including any ergonomic requirements.
- b) Maintenance instructions and schedules which include lubrication, testing, inspection and repair procedures.
- c) Operating instructions which incorporate clear instructions for the operation of the conveyor system from start up to shut down including all possible sequences of control.
- d) Emergency procedures.

16. SAFE WORK PROCEDURES

16.1. General

The owner of a conveyor or conveyor system needs to ensure safe work procedures are developed and incorporated into the operation of the conveyors or conveyor systems. These procedures should include.

16.2. Isolation procedure

The isolation procedure should incorporate a tagging system, a locking system or permit system and in any case should also include a method for ensuring that isolation is effectively established.

16.3. Operating procedures

These procedures need to cover all work to be undertaken by trained competent operators and need to include—

- a) Pre-start checks;
- b) Normal start / stop
- c) Hazard control;
- d) Isolation;
- e) Loading and unloading;
- f) Emergency; and
- g) Shutdown.

16.4. Maintenance procedures

These procedures need to cover all work to be undertaken by trained competent maintenance personnel and should include the following-

- a) Isolation requirements for the type of maintenance being undertaken.
- b) Access incorporating the removal and replacement of guards.
- c) Competent replacement and repair.
- d) Use of materials.
- e) Use of tools and test equipment.
- f) Housekeeping.
- g) Inspection and periodic adjustments.
- h) Breakdown activities.
- i) Recording and documenting activities.

17. MAINTENANCE MANAGEMENT

17.1. General

A maintenance management program needs to be incorporated into the operation of conveyors or conveyor systems to ensure satisfactory operation while in service.

The program should include the following:

- a) Pre-operational servicing including lubrication requirements.
- b) Periodic and or condition based servicing.
- c) Periodic inspections.
- d) Testing and inspection of safety equipment.
- e) Records, including but not limited to reporting overloads and damage.
- f) Compliance auditing.

18. Training

Competency based training must be provided for installers, commissioners, dismantlers, operators and maintenance personnel and other persons exposed to a hazard from a conveyor. The training needs to be relevant to the procedures associated with installation, commissioning, dismantling, operating and maintenance of the conveyor or conveyor system.

This training must include but is not limited to the following:

- a) Safe work practices including isolation procedures.
- b) Emergency procedures.
- c) Correct operation of the conveyor.
- d) Hazard identification, reporting, control and management.
- e) Reasons for protective devices including guards.
- f) Selection and care of personal protective equipment.
- g) Need for good housekeeping.
- h) Statutory requirements.
- i) Electrical and mechanical safety.
- j) Document management and control.

FURTHER ASSISTANCE

MAQOHSC Work Health and Safety Specialists are available to provide further advice and assistance on all Work Health and Safety matters.

MAQOHSC Work Health and Safety Specialists are able to be contacted via our website at www.maqohsc.sa.gov.au or email maqohsc@sa.gov.au.

ADDITIONAL INFORMATION

Work Health and Safety Legislation, Codes of Practice, fact sheets, Health and Safety Representatives (HSR) information and guides can be found at the following websites:

SafeWork SA – www.safework.sa.gov.au or call 1300 365 255

Safe Work Australia – www.safeworkaustralia.gov.au or call 1300 551 832

REFERENCES

Work Health and Safety Act 2012 (SA)

Work Health and Safety Regulations 2012 (SA)

Managing the Risks of Plant in the Workplace, Code of Practice (SafeWork SA)

AS 1755:2000 - Conveyors – Safety Requirements

AS 4024.1:2014 - Safety of Machinery

AS 1657:2013 - Fixed platforms, walkways, stairways and ladders—Design, construction and installation

Mining and Quarrying
Occupational Health and
Safety Committee

World Park A Building
Level 4, 33 Richmond Road
Keswick SA 5035

Telephone (08) 8204 9842
www.maqohsc.sa.gov.au

