



Classic



Innovative



Versatile

Microwave Push-on Interconnects



Simplified



Adaptable



Integrated

TABLE OF CONTENTS

General Information

- II Who We Are
- III Custom Designs
- IV Reference Guide

GPO® Products

- 2 GPO Specifications
- 3 Blindmate Interconnects
- 5 Cable Connectors
- 15 PCB Mounts
- 17 Right Angle PCB Mounts
- 19 Flange Mounts
- 21 Edge Mounts
- 23 Surface Mounts
- 24 Thread-in Shrouds
- 27 Press-In Shrouds
- 28 Hermetic Shrouds
- 30 Loads
- 31 Hermetic Seals
- 31 Pins
- 33 Multiposition Blocks

GPPO® Products

- 36 GPPO Specifications
- 37 Blindmate Interconnects
- 38 Cable Connectors
- 45 PCB Mounts
- 47 Flange Mounts
- 48 Edge Mounts
- 50 Surface Mounts
- 51 Thread-in Shrouds
- 54 Hermetic Shrouds
- 55 Loads
- 56 Hermetic Seals
- 56 Pins
- 57 Multiposition Blocks

G3PO™ Products

- 66 G3PO Specifications
- 67 Blindmate Interconnects
- 68 Cable Connectors
- 69 PCB Mounts
- 69 Edge Mounts
- 70 Surface Mounts
- 70 Hermetic Shrouds
- 70 Loads
- 71 Pins
- 72 Multiposition Blocks

G4PO® Products

- 80 G4PO Specifications
- 81 Blindmate Interconnects
- 82 Cable Assemblies
- 82 PCB Mounts
- 84 Edge Mounts
- 84 Surface Mounts
- 85 Hermetic Shrouds
- 85 Multiposition Blocks

GMS® Products

- 90 GMS Specifications
- 91 Cable Connectors
- 94 Flange Mounts
- 95 Loads
- 96 ESD

SGMS™ Products

- 100 SGMS Specifications
- 101 Blindmate Interconnects
- 101 Cable Connectors
- 102 Flange Mounts
- 103 Thread-in Shrouds
- 104 Multiposition Blocks

Adapters

- 106 Adapter Matrices
- 107 GPO Within Series Adapters
- 109 GPO Between Series Adapters
- 118 GPPO Within Series Adapters
- 119 GPPO Between Series Adapters
- 123 G3PO Adapters
- 125 G4PO Adapters
- 126 GMS Adapters
- 129 GMS ESD Adapters
- 130 SGMS Adapters

Tools

- 134 Bullet Install/Removal Tool Guide
- 136 GPO Tools
- 142 GPPO Tools
- 145 G3PO Tools
- 146 G4PO Tools
- 147 GMS Tools
- 148 Miscellaneous Tools

Technical Guide

- 150 Cable Assemblies
- 151 Test Capabilities
- 151 Connector Evaluation Kits
- 152 Assembly Procedures
- 156 Custom Packaging
- 157 Application Notes

Index

- 185 Index

Who We Are

With over 50 years of leading-edge design experience, Corning Gilbert exceeds industry standards with high performance coaxial connectors for broadband telecommunication and microwave systems. Corning Gilbert pioneered the GPO®, GPPO®, G3PO™, G4PO®, SGMS™ and GMS® connectors – setting the industry gold standard for coaxial push-on interconnects. First developed for demanding military applications, these systems are increasingly seen as the high frequency interconnects of choice for military, satellite, wireless and telecommunications applications.

Our goal is to provide design engineers with high performance interconnect solutions that can be easily integrated into today's sophisticated applications.

Our dedicated facility for microwave products enables us to provide exceptional customer and design services with excellent delivery and unparalleled quality. Our manufacturing facility is designed to provide both design flexibility and cost effective components that are controlled to extremely tight tolerances.

Corning Gilbert operates its manufacturing facilities under the ISO 9001 quality system. Headquartered in Glendale, AZ, its state-of-the art facilities adhere to stringent production guidelines to provide our customers with the highest level of reliability, consistency and quality, while meeting applicable military and commercial standards.

Corning Gilbert is a wholly owned subsidiary of Corning Incorporated. Established in 1851, Corning creates leading edge technologies for the fastest growing markets of the world's economy. Corning manufactures optical fiber, cable and photonic products for the telecommunications industry, and high performance display components for computers, television, and their communications related industries. Corning also uses advanced materials to manufacture products for scientific, semiconductor and environmental markets.

Customer Care

Our knowledgeable staff is available Monday - Friday to provide prompt assistance with your order placement and shipment inquiries. Let our customer care team answer your questions or suggest alternative, efficient ways of achieving your interconnect objectives.

phone: 800 651 8869 (U.S. and Canada)
(01) 623 845 5613 (International)
e-mail: pushon-info@corning.com

Custom Designs

Custom designs are supported by a team of innovative engineers, technicians, and machinists at Corning Gilbert. Our highly skilled staff will help you define your requirements and customize a design for the application. We understand that the goal is to quickly design and manufacture these specialized interconnects for electrical, mechanical, and environmental evaluation.



Corning Gilbert offers various custom design solutions including multiposition blocks, hermetic shrouds, cable connectors, PCB mounts, blindmate interconnects (BMI), loads, and adapters. Special packaging is also available, such as custom trays and tape & reel for automated pick and placement. Other custom options include selective plating and solder dipping. A typical design cycle begins with a discussion between the applications engineer and the customer to identify the interconnect requirements. Our library of designs are used as a basis for assessing your needs so that your exact requirements may be met with the highest efficiency. After receipt of order, our design engineer will create 3D CAD models which are optimized for electrical performance using electromagnetic simulation software. This allows tuning for a specific frequency range or broadband performance. Complex designs may require mechanical analysis using finite element analysis (FEA) software.

Complete with high precision Swiss turning centers and CNC mills, our dedicated machine shop is equipped to produce the custom designs you need. We also maintain a plating shop which enables passivation or plating of metallic components. Many validation tests are performed in-house. Electrical tests include voltage standing wave ratio (VSWR), dielectric withstanding voltage (DWV) and insulation resistance. Mechanical tests include durability and mating forces. Environmental tests include thermal cycling, humidity, and salt spray. Contact our customer care team for more information.

How to Reach Us

Corning Gilbert Inc.

Corporate Headquarters

5310 West Camelback Rd.
Glendale, AZ 85301 U.S.A.

phone: 800 651 8869 (U.S. and Canada)
(01) 623 845 5613 (International)
fax: (01) 623 934 5160
website: www.corning.com/gilbert
e-mail: pushon-info@corning.com

Reference Guide

Symbols

CC	Center Conductor	FD	Full Detent
LD	Limited Detent	mm	Millimeter
MP	Microporous	PCB	Printed Circuit Board
R/A	Right Angle	R/P	Reference Plane
S/R	Semi-Rigid	SB	Smooth Bore
SQ	Square	∅	Diameter
RF	Radio Frequency	GHz	Gigahertz
dB	Decibels	VSWR	Voltage Standing Wave Ratio
CM	Catchers Mitt		
XD	Extra Deep	SI	Short Interface

Standard Tolerances

All dimensions are in inches, interpretation per ANSI Y14.5.

.XX ± .010

.XXX ± .005

Fractions ± 1/64

Angular ± 5°

Typical machine surface finish 63 micro inches

Common Materials and Finishes

- Beryllium copper per ASTM B 196 and/or ASTM B 197. Gold plate per ASTM B 488 over electrolytic nickel per SAE AMS QQ N 290.
- CRES 303 per ASTM A 484 and ASTM A 582 or ASTM A 555 and ASTM A 581. Passivate per SAE AMS 2700.
- Brass per ASTM B 16. Gold plate per ASTM B 488 over electrolytic nickel per SAE AMS QQ N 290.
- Virgin TEFLON® PTFE fluorocarbon per ASTM D 1710.
- KOVAR® Iron-nickel-cobalt sealing alloy per ASTM F 15. Gold plate per ASTM B 488 over electrolytic nickel per SAE AMS QQ N 290.
- Corning® 7070 glass or equivalent.
- Ultem® 1000 (Polyetherimide) per ASTM D 5205.
- Torlon® (Polyamide-Imide) per ASTM D 5204.

Detent

A captivation system was developed for the GPO®, GPPO®, G3PO™ and G4PO® interconnect systems that provides predictable levels of retention without the use of bulky coupling nuts. This feature is characterized as the connector’s detent.

The GPO product is designed with three available detent levels, and two detents exist within the smaller GPPO, G3PO and G4PO series. This is accommodated by the incorporation of a ring in the male pin connector (commonly known as the shroud). This ‘detent ring’ interacts with the mating connector (female contact) to captivate the pair together.

Each of the detent levels, full detent, limited detent (available only in the GPO series), and smooth bore (or zero detent) provide different levels of force required to mate and de-mate the connectors.

	Engage*				Disengage*				Cycles*			
	GPO	GPPO	G3PO	G4PO	GPO	GPPO	G3PO	G4PO	GPO	GPPO	G3PO	G4PO
Full Detent	7.0 lbs	4.5 lbs	2.5 lbs	.65 lbs	9.0 lbs	6.5 lbs	4.5 lbs	2.2 lbs	100 min	100 min	100 min	100 min
Limited Detent	5.0 lbs	N/A	N/A	N/A	7.0 lbs	N/A	N/A	N/A	500 min	N/A	N/A	N/A
Smooth Bore	3.0 lbs	2.5 lbs	1.2 lbs	.20 lbs	0.5 lbs	1.5 lbs	1.0 lbs	.15 lbs	1000 min	500 min	500 min	500 min

* The figures listed for the engage/disengage forces are typical and based upon actual data.

Proper care should be used when designing your system to select the required forces for engaging and disengaging. The level of detent selected will also have an impact on the number of engage/disengage cycles. Note, female cable connectors MUST be used with a full detent male to maintain a fully mated condition during shock and vibration.

GPO Products

- Center-to-center spacing of 0.170" available for increased package density
- Frequency from DC to 40 GHz
- Designed to accommodate both radial and axial misalignment with negligible VSWR change



GPO® Specifications

General Characteristics

Impedance	50 ohms nominal
Frequency range	DC to 40 GHz
Temperature range	-65°C thru 165°C

Electrical Characteristics

VSWR	1.15:1 to 26.5 GHz typical; <1.5:1 typical to 40 GHz
Insertion loss	.04 √f (GHz)
DWV@ Sea Level	500 Vrms
Insulation resistance	5,000 megohms min.
Contact resistance	
Outer conductor	2 milliohms max.
Inner conductor	6 milliohms max.
RF leakage	-80 dB to 3 GHz, -65 dB to 26.5 GHz

Mechanical Characteristics

Mate/Demate Cycles	FD - 100min.; LD - 500min.; SB - 1000min.;
Force to engage/disengage	FD - 7.0lbs.typ./9.0lbs.typ.;
	LD - 5.0lbs.typ./7.0lbs.typ.;
	SB - 3.0lbs.typ./0.5lbs.typ.
Tolerated misalignment	
Radial	+/- 0.010
Axial	0.010 (flush to 0.010 from the reference plane)

Environmental Characteristics

Thermal Shock	MIL-STD-202, Method 107, Condition B
Salt Spray	MIL-STD-202, Method 101
Vibration	MIL-STD-202, Method 204
Shock	MIL-STD-202, Method 213, Condition I
Moisture resistance	MIL-STD-202, Method 106, except Step 7B

Materials (typical)

Bodies	Beryllium Copper per ASTM B196 and or/ASTM B197
Outer contacts	Beryllium Copper per ASTM B196 and or/ASTM B197
Center contacts	Beryllium Copper per ASTM B196 and or/ASTM B197
Insulators	PTFE Fluorocarbon per ASTM D1710
Springs	17-7 Stainless Steel per ASTM A313-95A

Finish (typical)

Bodies	Gold plated per MIL-G-45204, Type I, Grade C, Class 1, Over Nickel Plate per SAE AMS-QQ-N-290
Contacts	Gold plated per MIL-G-45204, Type I, Grade C, Class 1, Over Nickel Plate per SAE AMS-QQ-N-290

GPO Blindmate Interconnects

Female Blindmate Interconnect

Catalog Number	A	Catalog Number	A
A1A1-0001-01	.254	A1A1-0001-12	1.30
A1A1-0001-03	.395	A1A1-0001-21	1.00
A1A1-0001-07	.286	A1A1-0001-25	.517
A1A1-0001-08	.243	A1A1-0001-29	.286
A1A1-0001-11	.769		

VSWR (TYP)

- 1.10:1 to 8 GHz
- 1.35:1 to 26.5 GHz
- 1.5:1 to 40 GHz

Note: Bullets of almost any length can be created to suit your application. Please contact customer service for further information.

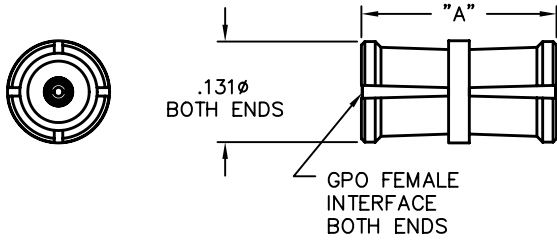

Female Blindmate Interconnect

Catalog Number

A1A1-0001-02

VSWR (TYP)

- 1.10:1 to 12 GHz
- 1.40:1 to 26.5 GHz

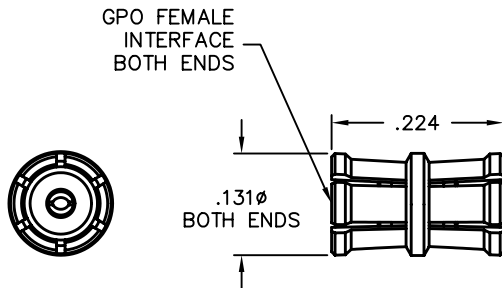

Female Blindmate Interconnect Self-Adjusting

Catalog Number

A1A1-0001-09

VSWR (TYP)

- 1.20:1 to 8 GHz
- 1.40:1 to 26.5 GHz

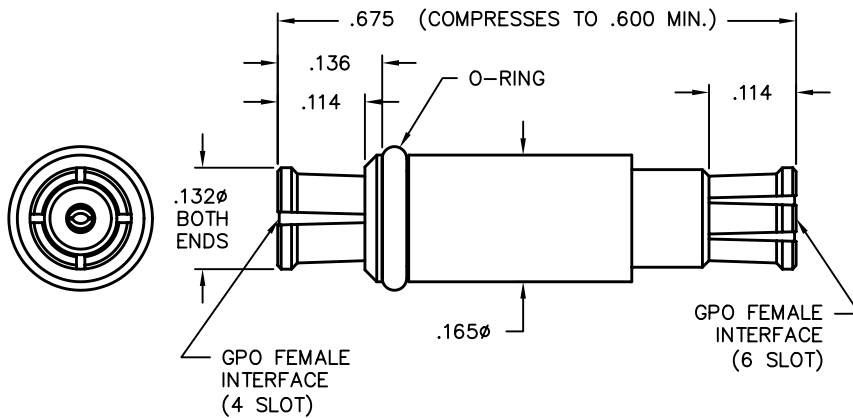

GPO Blindmate Interconnects

Spring Loaded Bullet

Catalog Number

A1A1-0001-34

Compression Length: .727

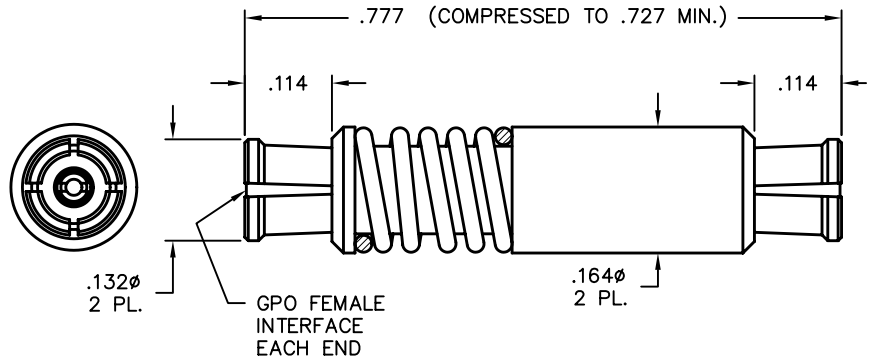

Female Blindmate Interconnect

Catalog Number

A1A1-0001-24

VSWR (TYP)

1.25:1 to 18 GHz

1.35:1 to 26.5 GHz

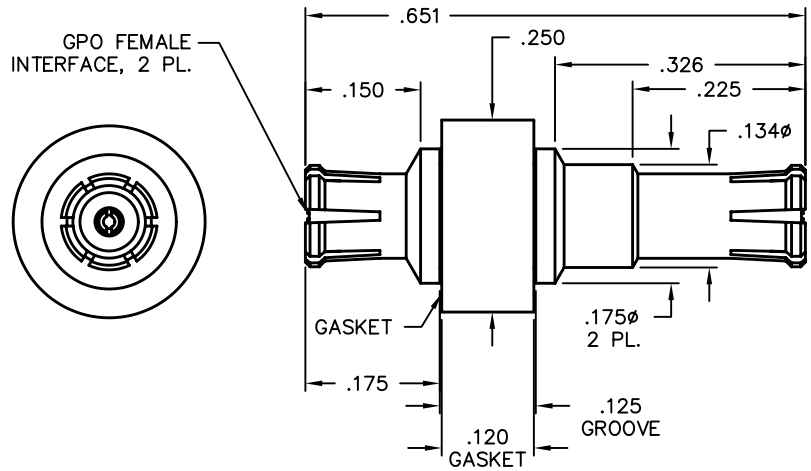

Female Snap-In Float Mount Adapter

Catalog Number

A1A1-0547-01

VSWR (TYP)

1.35:1 to 26.5 GHz

Compression Length: .466

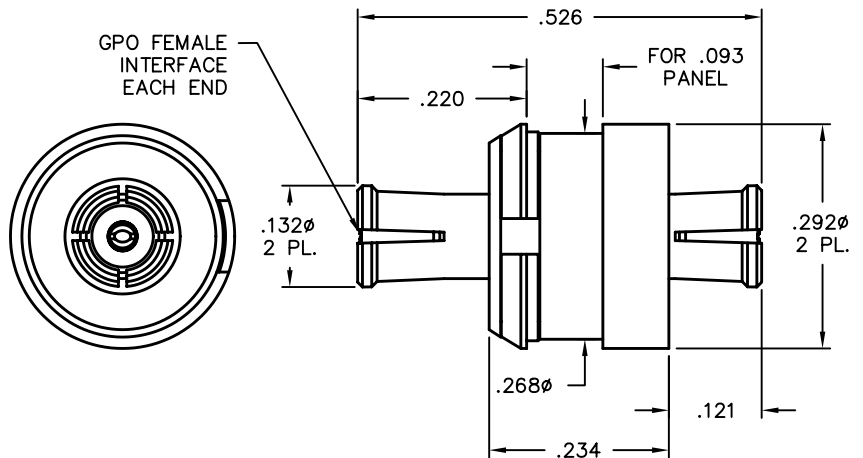

GPO Cable Connectors

Female Straight to 0.047 S/R Cable

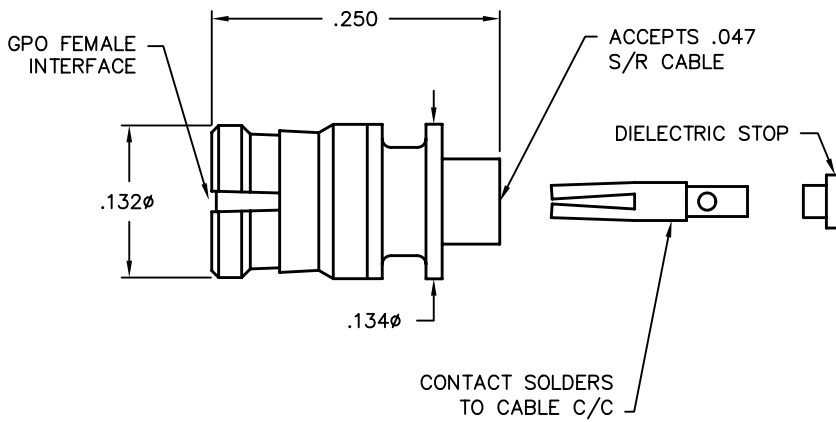

Catalog Number	Tools Recommended
A014-B11-01	A096-A99-02
VSWR (TYP)	L096-A99-02
1.25:1 to 26.5 GHz	A096-A99-06
	Assembly Procedure
	AP01-002



Male Flange Mount to 0.047 S/R Cable

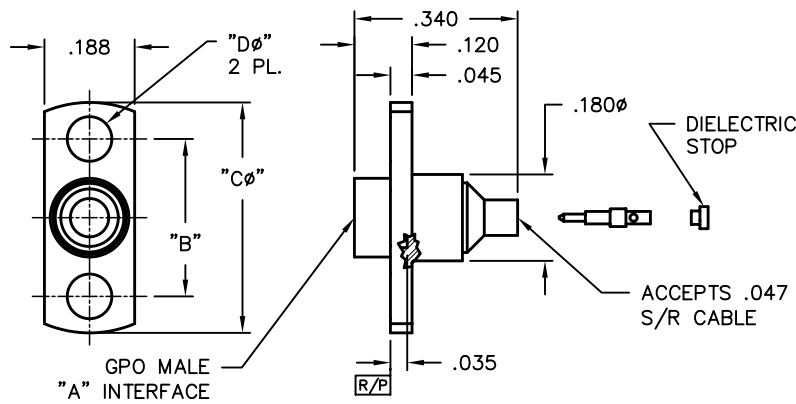

Catalog Number	A	B	Cφ	Dφ
A001-B83-01	FD	.328	.480	.093
A001-B84-01	LD	.328	.480	.093
A001-B85-01	SB	.328	.480	.093
A001-B83-02	FD	.282	.400	.073
A001-B84-02	LD	.282	.400	.073
A001-B85-02	SB	.282	.400	.073

VSWR (TYP)
1.25:1 to 26.5 GHz
Tools Recommended
A096-A99-04
L096-A99-02
9001-942-3
Assembly Procedure
AP01-014



Female Straight to 0.047 S/R Cable

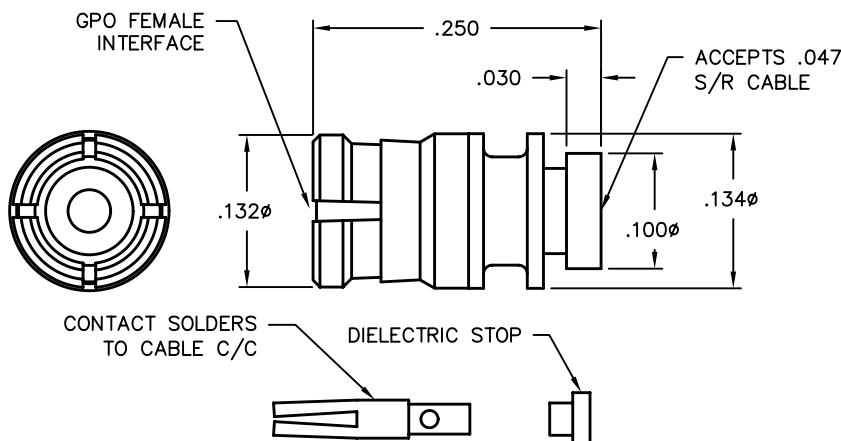

Catalog Number	Tools Recommended
0119-881-1	A096-A99-02
VSWR (TYP)	L096-A99-02
1.20:1 to 26.5 GHz	A096-A99-06
	Assembly Procedure
	AP01-002

GPO Cable Connectors

Female Straight to 0.086 S/R Cable

Catalog Number	Tools Recommended
A014-D11-01*	A096-A99-06
VSWR (TYP)	L096-A99-01
1.25:1 to 26.5 GHz	Assembly Procedure
	AP01-114

* For a flexible alternative, order A014-K11-06 to allow for heat shrink sleeve

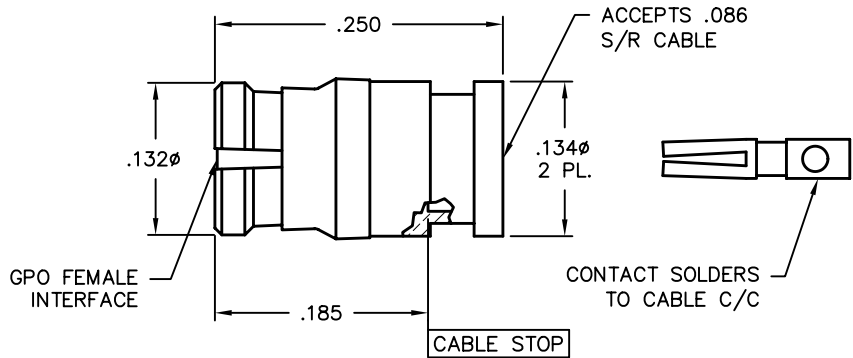

Female Straight to 0.086 S/R Microporous Cable

Catalog Number	Tools Recommended
A014-D11-02	9001-932-3
VSWR (TYP)	A096-A99-06
1.25:1 to 26.5 GHz	L096-A99-01
	Assembly Procedure
	AP01-071

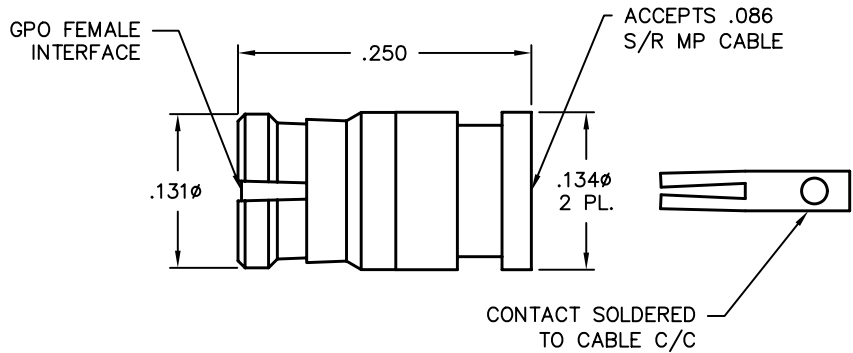

Male Flange Mount to 0.086 S/R Cable

Catalog Number	A	B	Cø	Dø
A001-D83-01	FD	.328	.480	.093
A001-D84-01	LD	.328	.480	.093
A001-D85-01	SB	.328	.480	.093
A001-D83-02	FD	.282	.400	.073
A001-D84-02	LD	.282	.400	.073
A001-D85-02	SB	.282	.400	.073

VSWR (TYP)
1.35:1 to 26.5 GHz

Tools Recommended
L096-A99-01
A096-A99-04
9001-942-3

Assembly Procedure
AP01-015

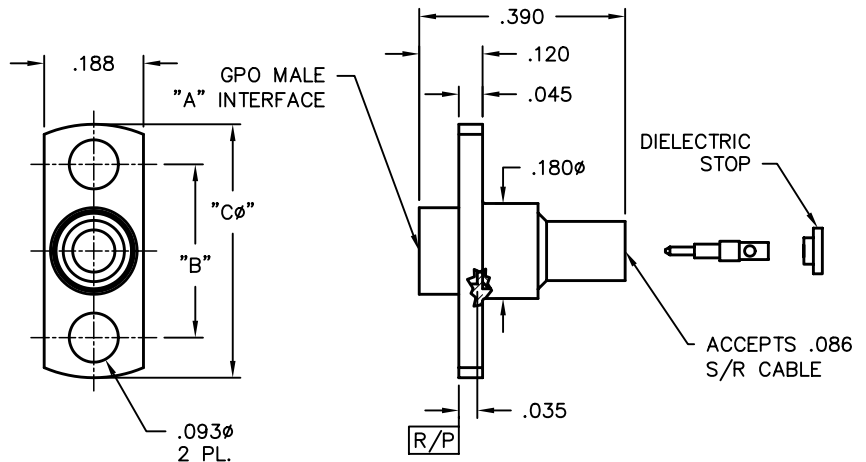

GPO Cable Connectors

Female Straight to 0.086 S/R Cable Solder Attach Center Conductor

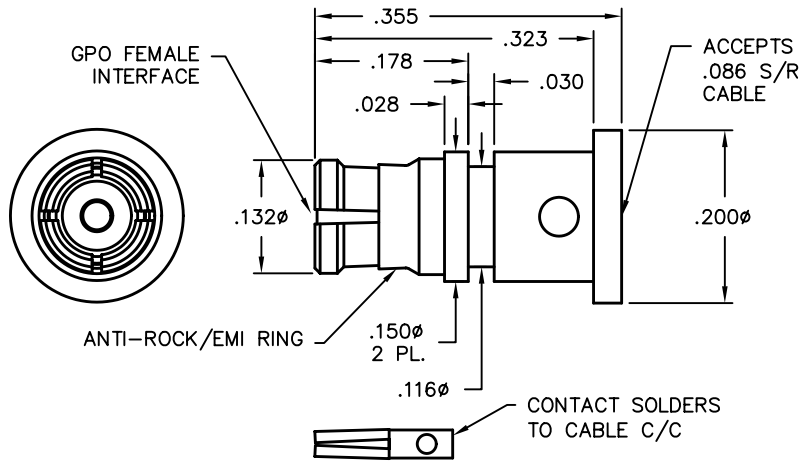

Catalog Number	Tools Recommended
0119-399-1	A096-A99-06
VSWR (TYP)	L096-A99-01
1.25:1 to 26.5 GHz	9001-932-3
	A096-A99-02
	Assembly Procedure
	AP01-131

Female Straight to RG-316 Cable

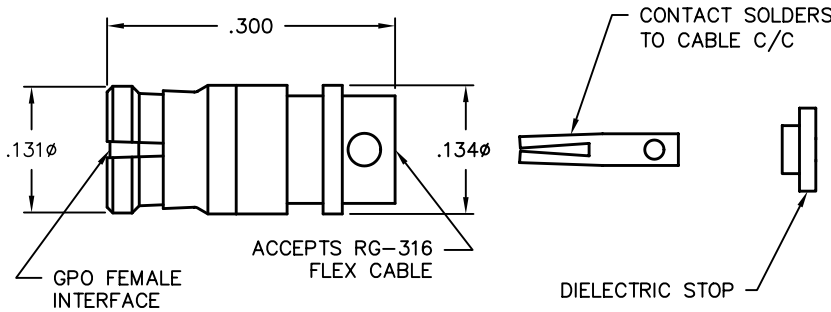

Catalog Number	Tools Recommended
A014-F71-01	A096-A99-06
VSWR (TYP)	L096-A99-01
1.10:1 to 4 GHz	A096-A99-02
	Assembly Procedure
	IS-7804-1



Female Straight to RG-178/196 Cable

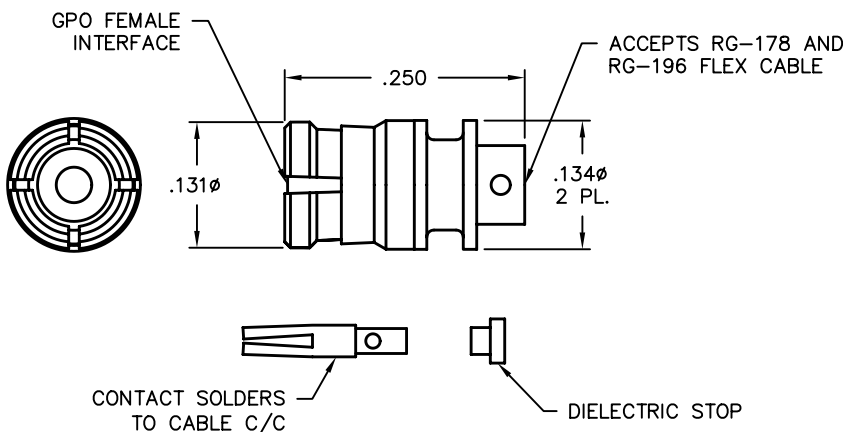

Catalog Number	Tools Recommended
A014-H71-01	A096-A99-02
VSWR (TYP)	L096-A99-01
1.15:1 to 4 GHz	A096-A99-06
	Assembly Procedure
	AP01-039



GPO Cable Connectors

Female R/A to 0.047 S/R Cable

<u>Catalog Number</u>	<u>Tools Recommended</u>
A015-B11-01	A096-A99-07
<u>VSWR (TYP)</u>	L096-A99-02
1.20:1 to 18 GHz	A096-A99-01
1.30:1 to 26.5 GHz	<u>Assembly Procedure</u>
	AP01-097

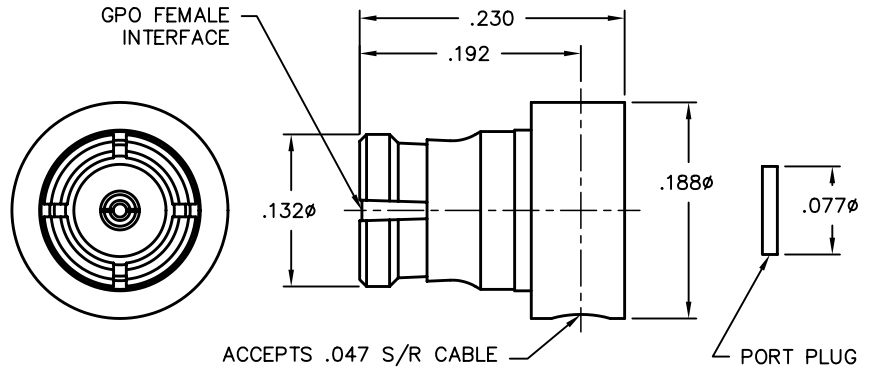

Female R/A to 0.047 S/R Cable

<u>Catalog Number</u>	<u>Tools Recommended</u>
A015-B11-02	A096-A99-01
<u>VSWR (TYP)</u>	A096-A99-07
1.25:1 to 26.5 GHz	L096-A99-02
	<u>Assembly Procedure</u>
	AP01-097

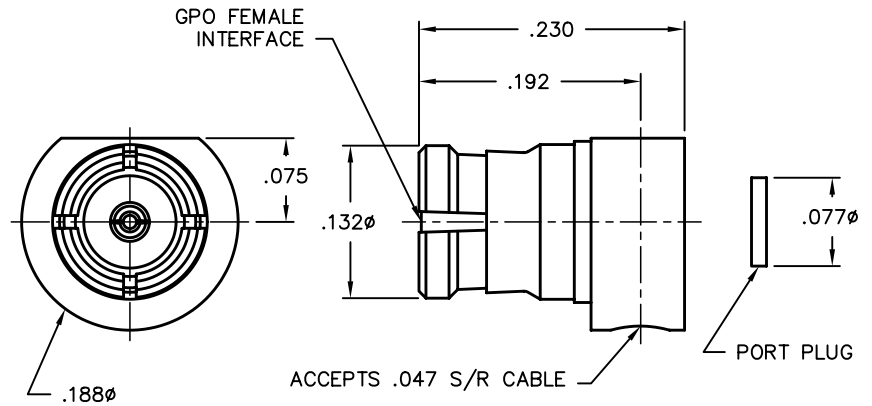

Female R/A to 0.047 S/R Cable

<u>Catalog Number</u>	<u>Tools Recommended</u>
A015-B71-01	A096-A99-01
<u>VSWR (TYP)</u>	A096-A99-07
1.25:1 to 26.5 GHz	L096-A99-02
	<u>Assembly Procedure</u>
	AP01-019

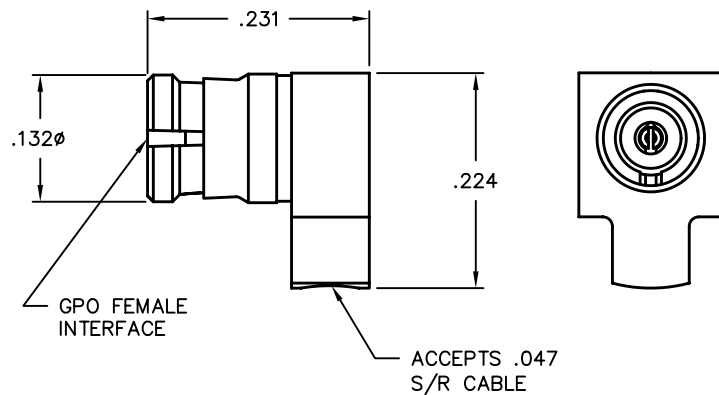

GPO Cable Connectors

Female Swept R/A to 0.047 S/R Cable

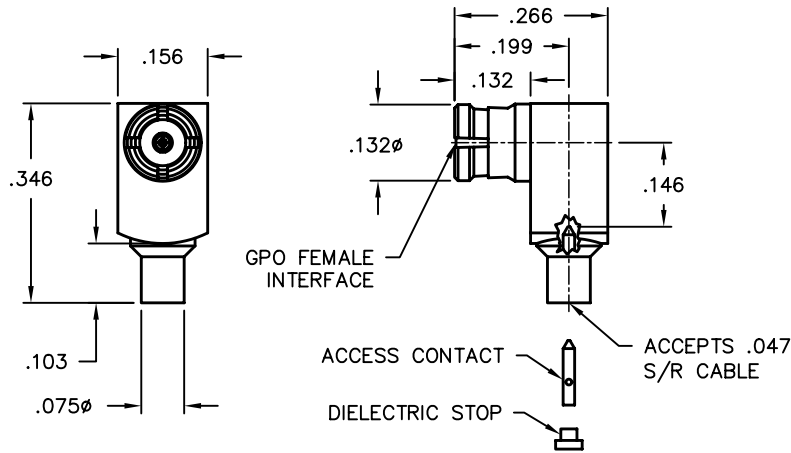

Catalog Number	Tools Recommended
A015-B71-03	A096-A99-01
VSWR (TYP)	L096-A99-02
1.20:1 to 18 GHz	A096-A99-01
1.40:1 to 26.5 Ghz	Assembly Procedure
	AP01-073

Female R/A to 0.086 S/R Cable

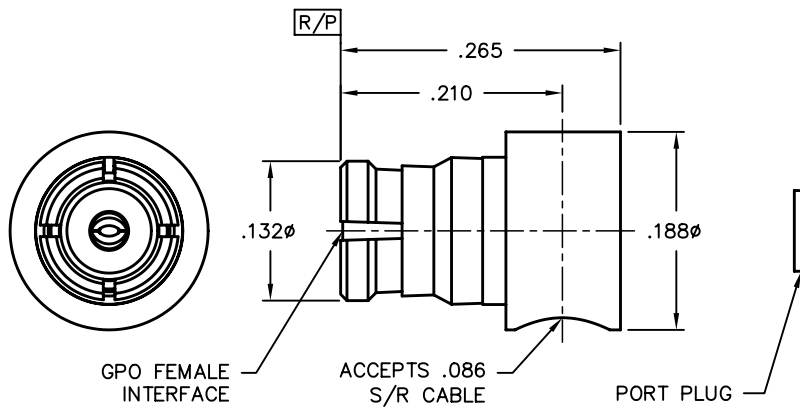

Catalog Number	Tools Recommended
A015-D11-01	A096-A99-01
VSWR (TYP)	L096-A99-01
1.10:1 to 18 GHz	A096-A99-07
1.20:1 to 26.5 Ghz	Assembly Procedure
	AP01-115



Female Swept R/A to 0.086 S/R Cable

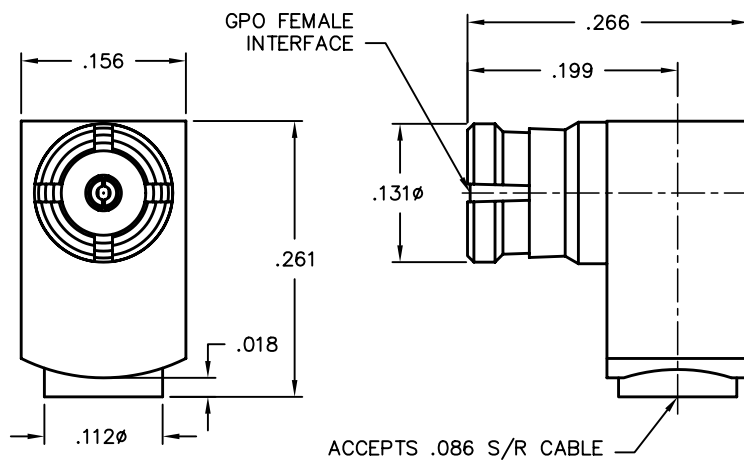

Catalog Number	Tools Recommended
A015-D11-03	A096-A99-02
VSWR (TYP)	L096-A99-01
1.15:1 to 18 GHz	A096-A99-01
1.25:1 to 40 GHz	Assembly Procedure
	AP01-072



GPO Cable Connectors

Male R/A to 0.086 S/R Cable

Catalog Number	A	Tools Recommended
0119-727-3-FD	FD	A096-A99-04
0119-727-3-LD	LD	Assembly Procedure
0119-727-3-SB	SB	AP01-038

VSWR (TYP)
1.10:1 to 26.5 GHz

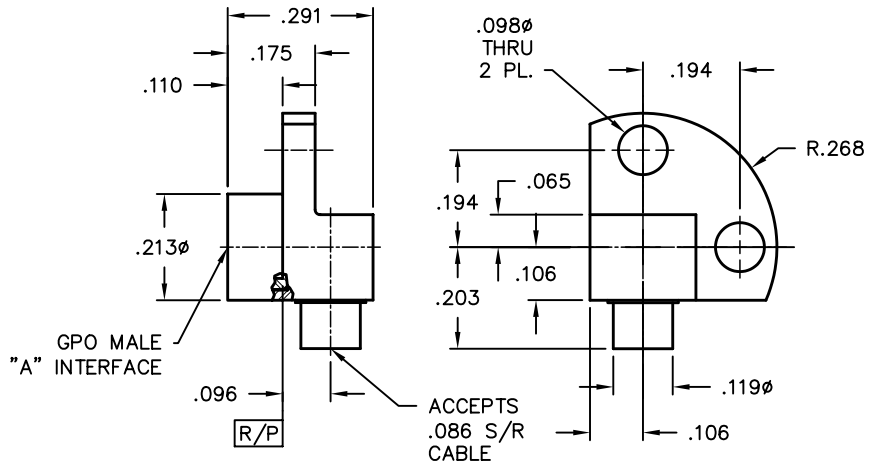

Female R/A to RG-316 Cable

Catalog Number	Assembly Procedure
A015-F71-01	AP01-125

VSWR (TYP)
1.05:1 to 3 GHz

Tools Recommended
A096-A99-02
A096-A99-01
A096-A99-08
L096-A99-01

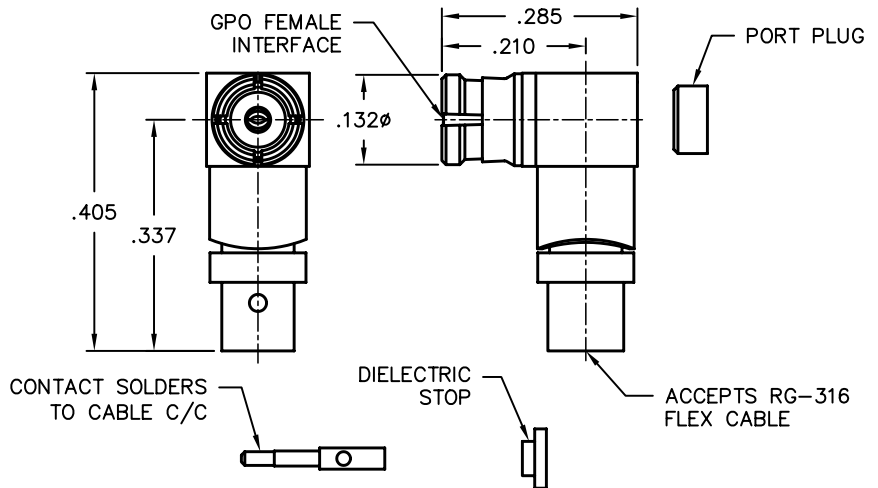

Female R/A to RG-178/196 Cable

Catalog Number	Assembly Procedure
A015-H71-01	AP01-040

VSWR (TYP)
1.15:1 to 3 GHz

Tools Recommended
A096-A99-02
A096-A99-01
A096-A99-08
L096-A99-01

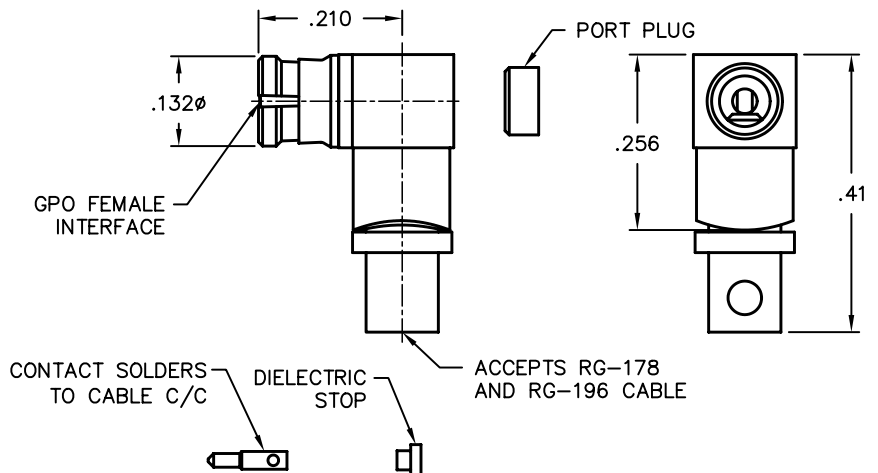

GPO Cable Connectors

Female R/A to UFF-092A Flex Cable

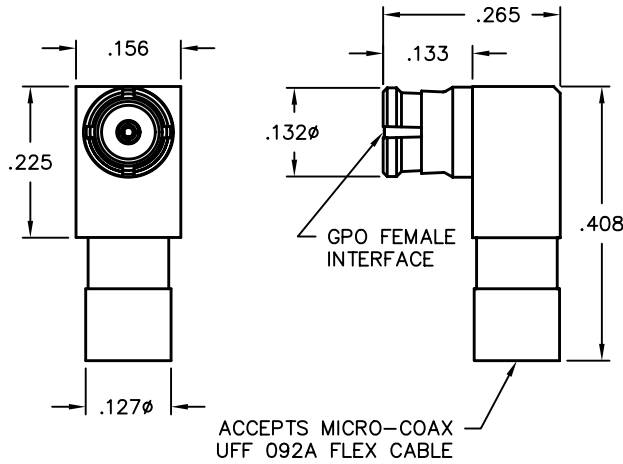

Catalog Number	Tools Recommended
0119-303-1	A096-A99-06
VSWR (TYP)	A096-A99-01
1.30:1 to 18 GHz	L096-A99-01
1.35:1 to 26.5 GHz	Assembly Procedure
	AP01-061



Male Bulkhead Mount to 0.047 S/R Microporous Cable

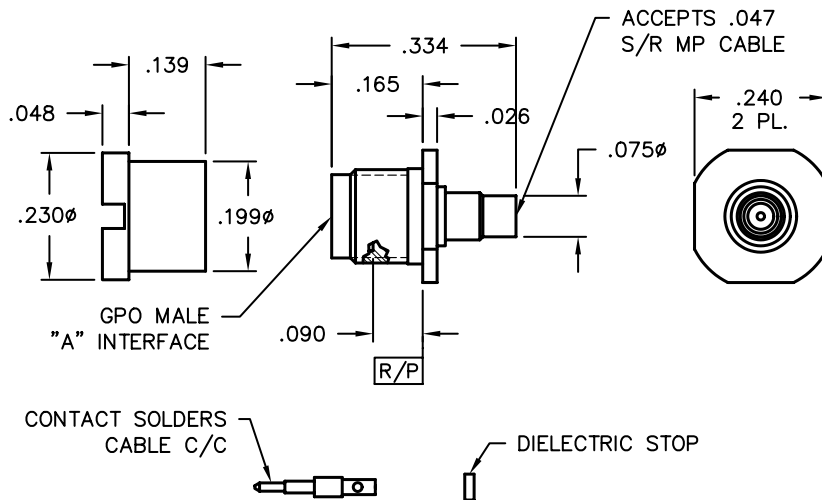

Catalog Number	A	Tools Recommended
A016-B83-01	FD	A096-A99-04
A016-B84-01	LD	9001-942-3
A016-B86-01	CM	L096-A99-02
VSWR (TYP)		Assembly Procedure
1.20:1 to 26.5 GHz		AP01-063



Male Bulkhead Mount Smooth Bore Thread-on to 0.047 S/R Cable

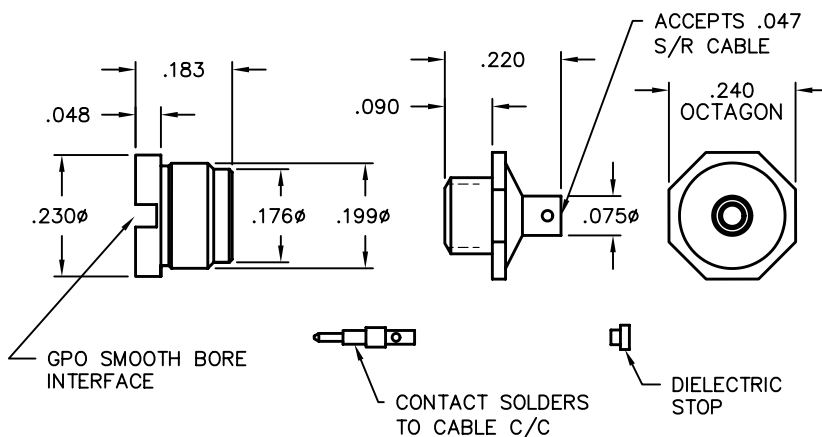

Catalog Number	Tools Recommended
0119-546-3	A096-A99-04
VSWR (TYP)	9001-942-3
1.20:1 to 26.5 GHz	L096-A99-02
	Assembly Procedure
	AP01-023



GPO Cable Connectors

Male Snap-in to 0.086 S/R Cable

Catalog Number	A	Tools Recommended
A016-D53-01	FD	9001-942-3
A016-D54-01	LD	L096-A99-04
A016-D55-01	SB	L096-A99-01
VSWR (TYP)		Assembly Procedure
1.15:1 to 18 GHz		AP01-087
1.30:1 to 26.5 GHz		

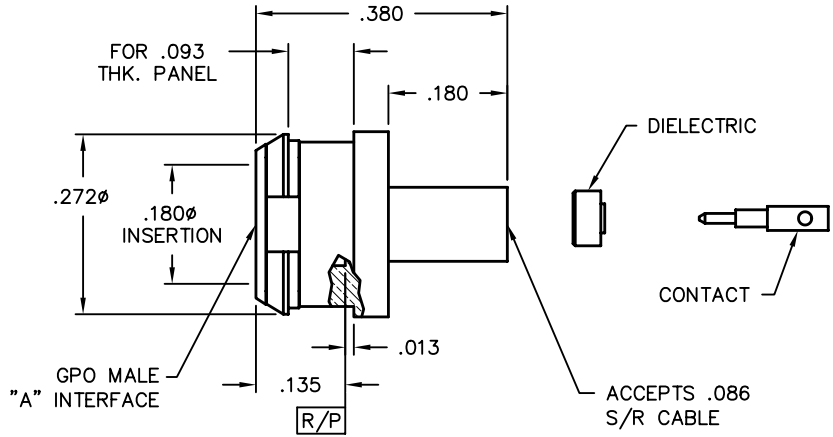

Male Bulkhead Mount to 0.086 S/R Cable

Catalog Number	A	Tools Recommended
A016-D73-03	FD	A096-A99-02
A016-D74-03	LD	9001-932-3
A016-D76-03	CM	A096-A99-03
VSWR (TYP)		Assembly Procedure
1.15:1 to 18 GHz		AP01-123
1.25:1 to 26.5 GHz		

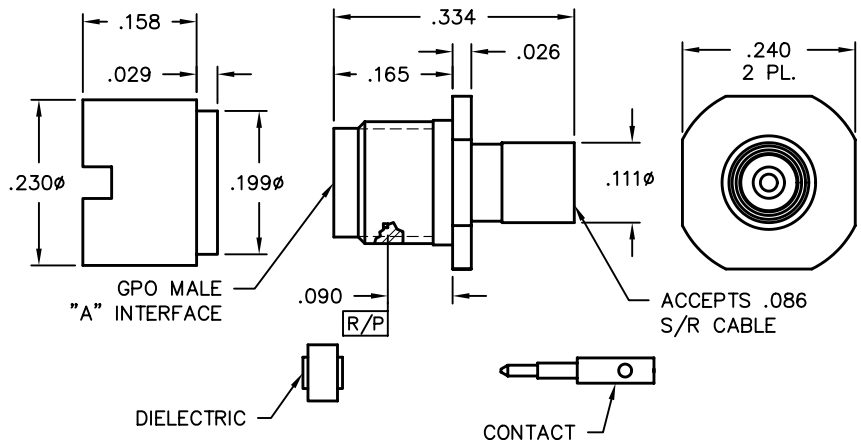

Male Bulkhead Mount to 0.086 S/R Cable

Catalog Number	A	Tools Recommended
A016-D83-01	FD	A096-A99-02
A016-D84-01	LD	L096-A99-01
A016-D86-01	CM	A096-A99-03
VSWR (TYP)		Assembly Procedure
1.25:1 to 26.5 GHz		AP01-050

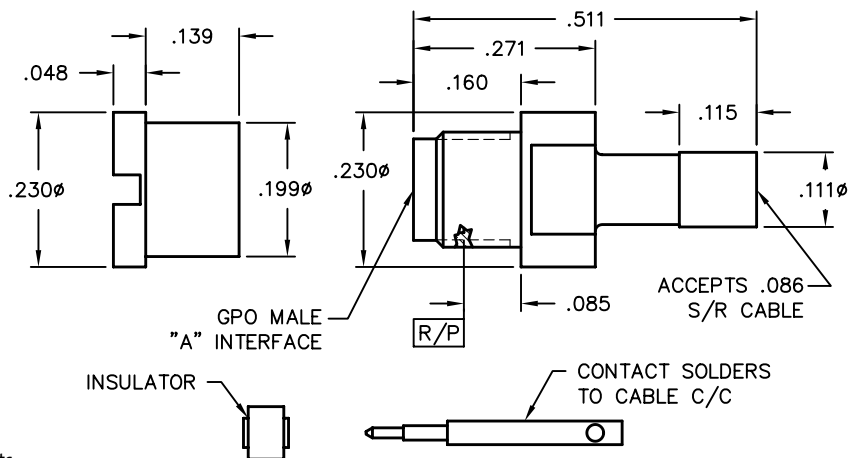

GPO Cable Connectors

Male Modified Smooth Bore Catchers Mitt Bulkhead Mount to 0.086 S/R Cable

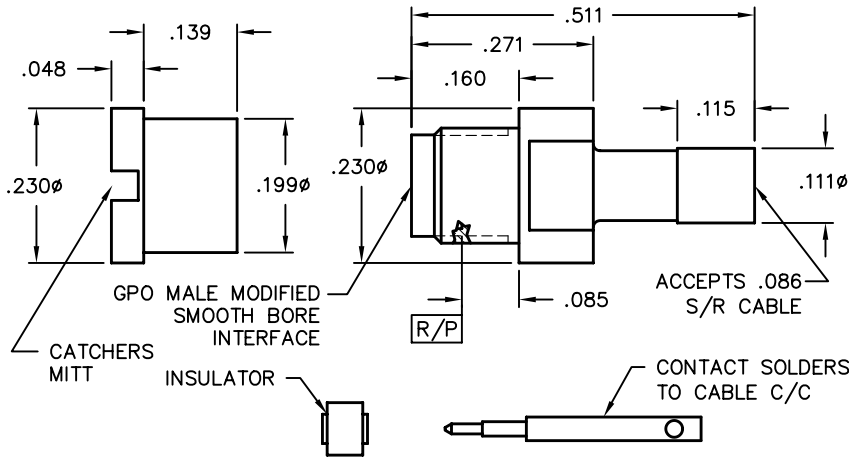

Catalog Number	Tools Recommended
A016-D87-01	A096-A99-02
VSWR (TYP)	L096-A99-01
1.25:1 to 18 GHz	A096-A99-03
1.35:1 to 26.5 GHz	Assembly Procedure
	AP01-050



Male Bulkhead Mount to RD-316 Cable

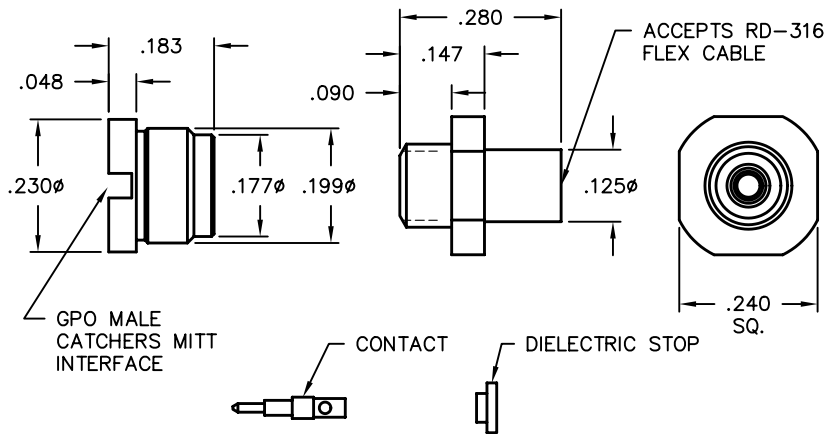

Catalog Number	Tools Recommended
A016-G86-01	A096-A99-04
VSWR (TYP)	L096-A99-01
1.15:1 to 3 GHz	A096-A99-03
	Assembly Procedure
	AP01-029



Male Bulkhead Mount to RG-178/196 Cable

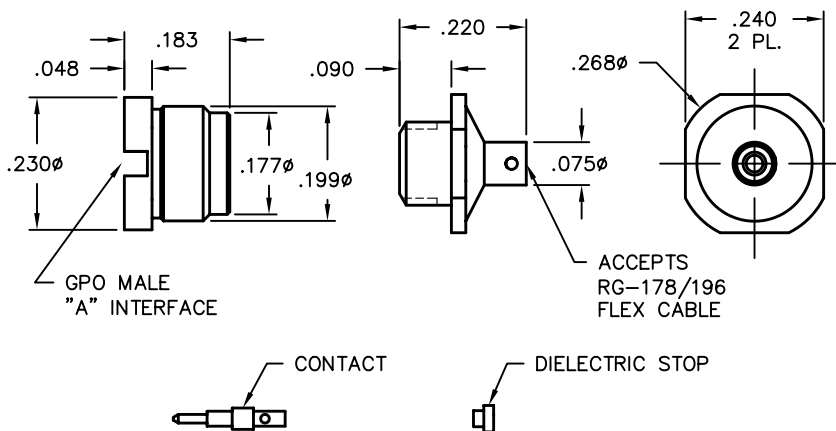

Catalog Number	A	Tools Recommended
A016-H83-01	FD	A096-A99-04
A016-H84-01	LD	L096-A99-01
A016-H85-01	SB	A096-A99-03
VSWR (TYP)		A018-B71-01
1.20:1 to 3 GHz		Assembly Procedure
		IS-7095-5



GPO Cable Connectors

Female Snap-in Float Mount to 0.047 and 0.047 S/R Microporous Cable

Catalog Number	A	B	C	D
A018-B71-01	.495	.221	.093	.234
A018-B71-02	.530	.254	.150	.230

VSWR (TYP)	Assembly Procedure
1.15:1 to 18 GHz	IS-7582-1
1.25:1 to 26.5 GHz	

- Tools Recommended**
- A096-A99-02
 - L096-A99-02
 - A096-A99-06

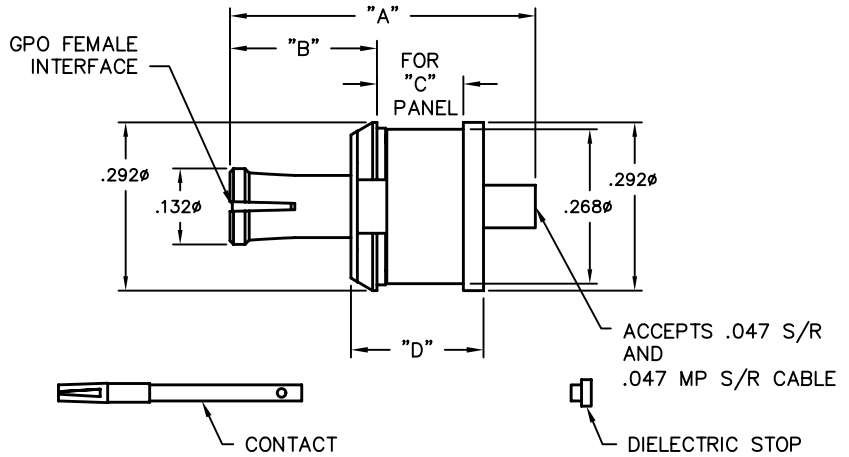

Female Snap-in Float Mount to RG-316 Cable

Catalog Number	Assembly Procedure
A018-F71-01	AP01-049

VSWR (TYP)	Compression Length: .439
1.15:1 to 3 GHz	

- Tools Recommended**
- A096-A99-02
 - L096-A99-01
 - A096-A99-06

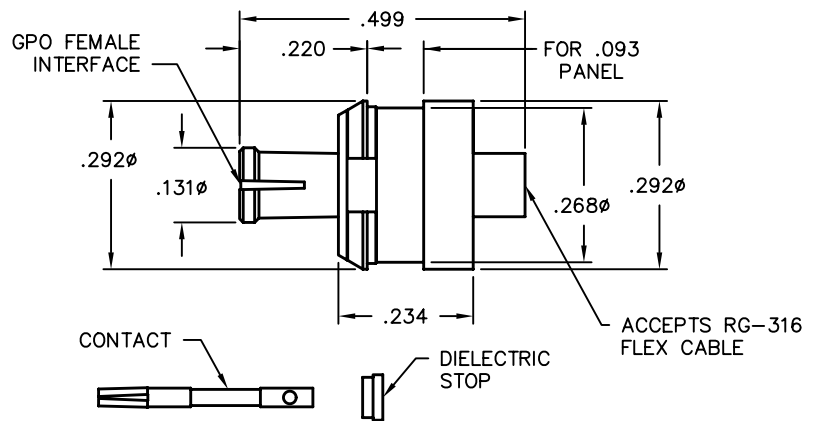

Female Snap-in Float Mount to RG-178 Cable

Catalog Number	Assembly Procedure
0119-392-3	AP01-078

VSWR (TYP)	Compression Length: .439
1.15:1 to 4 GHz	

- Tools Recommended**
- A096-A99-02
 - L096-A99-01
 - A096-A99-06

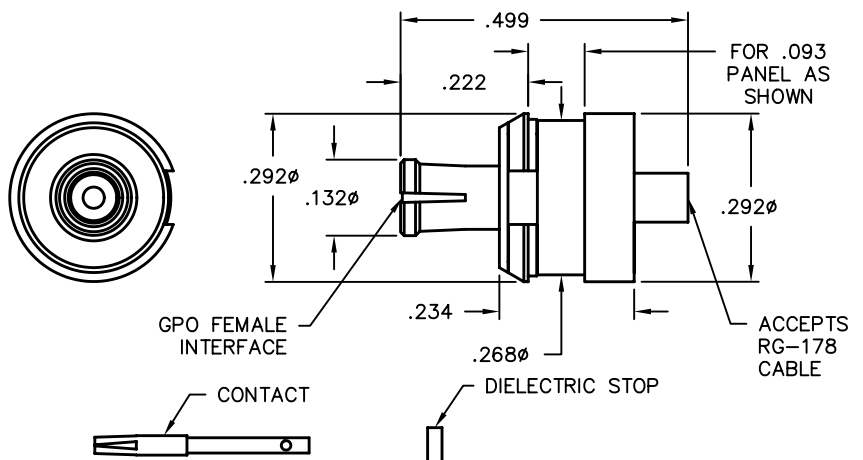

GPO Cable Connectors

Male Catchers Mitt Bulkhead Float Mount to 0.141 Microporous S/R Cable

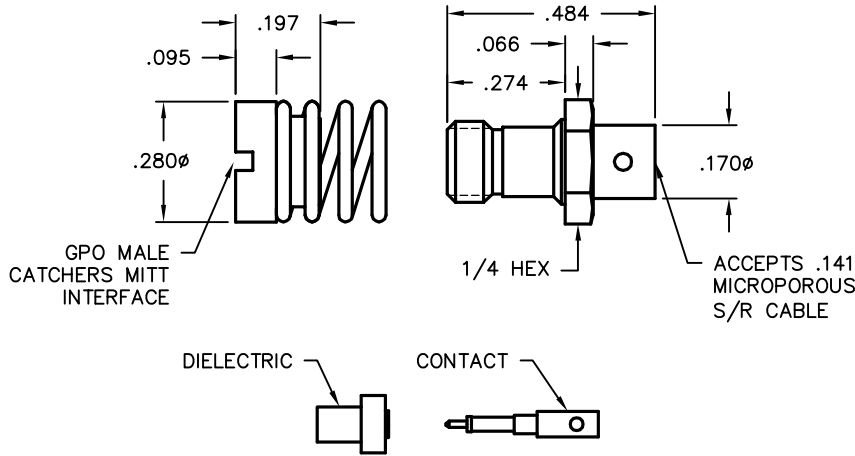

Catalog Number	Assembly Procedure
0119-590-3	AP01-045

- Tools Recommended**
- A096-A99-02
 - L096-A99-01
 - A096-A99-09



GPO PCB Mounts

Male Straight to PCB

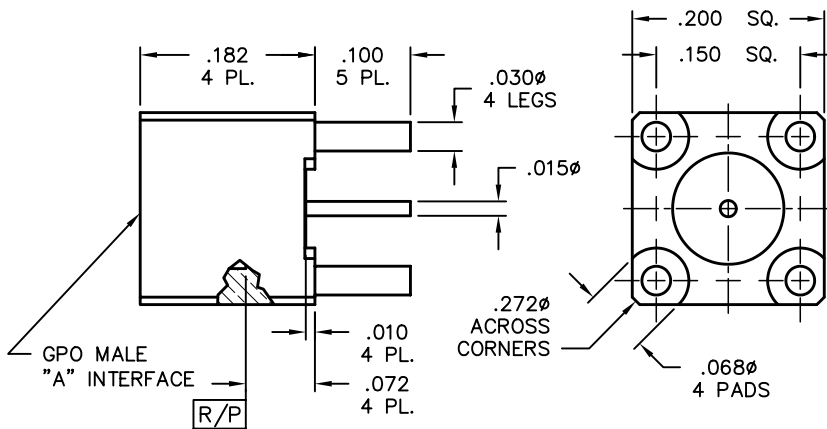

Catalog Number	A
A008-L13-03	FD
A008-L14-03	LD
A008-L15-03	SB
VSWR (TYP)	
1.30:1 to 20 GHz	



Male PCB 4 Leg Thru Mount Cap Center Conductor

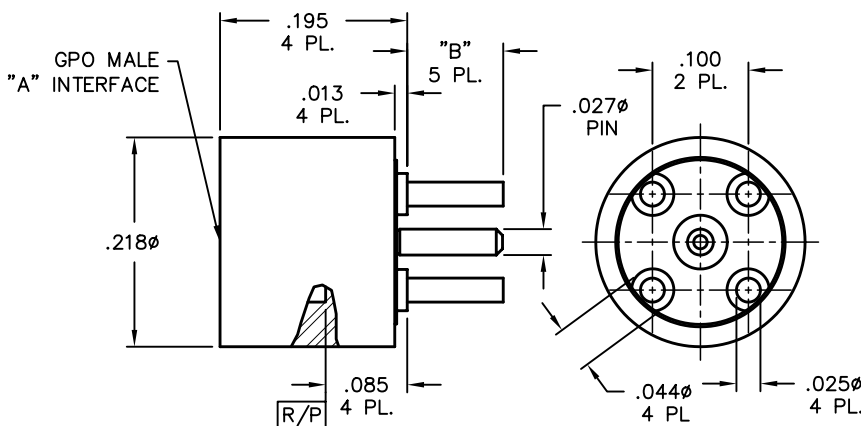

Catalog Number	A	B
A008-L33-01	FD	.100
A008-L34-01	LD	.100
A008-L35-01	SB	.100
A008-L33-02	FD	.140
A008-L34-02	LD	.140
A008-L35-02	SB	.140
VSWR (TYP)		
1.30:1 to 20 GHz		



GPO PCB Mounts

Male PCB 4 Leg Thru Mount Separate C/C

Catalog Number	A
A008-L33-05	FD
A008-L34-05	LD
A008-L35-05	SB

VSWR (TYP)
1.30:1 to 20 GHz

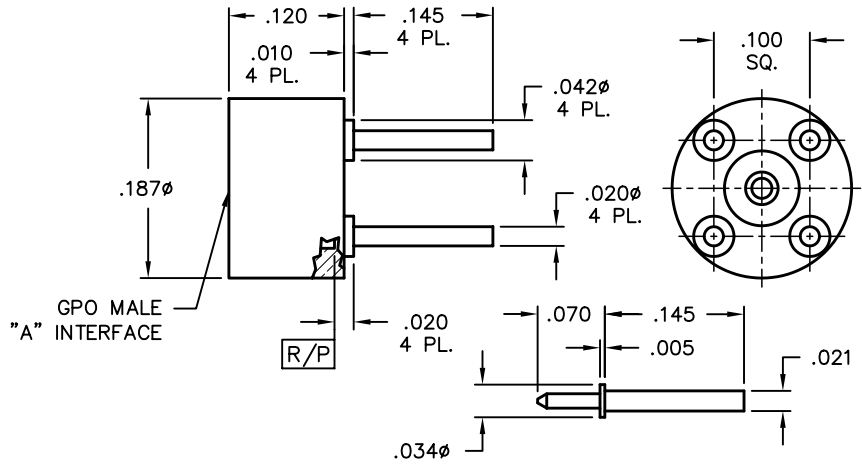

Male Full Detent PCB 3 Pin Thru Hole

Catalog Number	A
A008-L33-06	

VSWR (TYP)
1.30:1 to 20 GHz

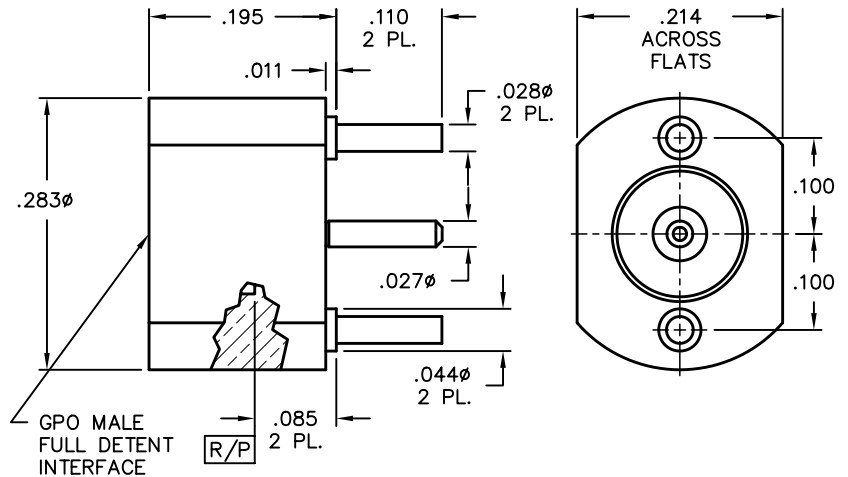
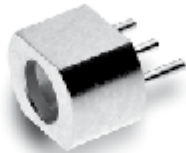

Male PCB 4 Leg Thru Mount R/A Center Conductor

Catalog Number	A
A008-P33-01	FD
A008-P34-01	LD
A008-P35-01	SB

VSWR (TYP)
1.30:1 to 20 GHz

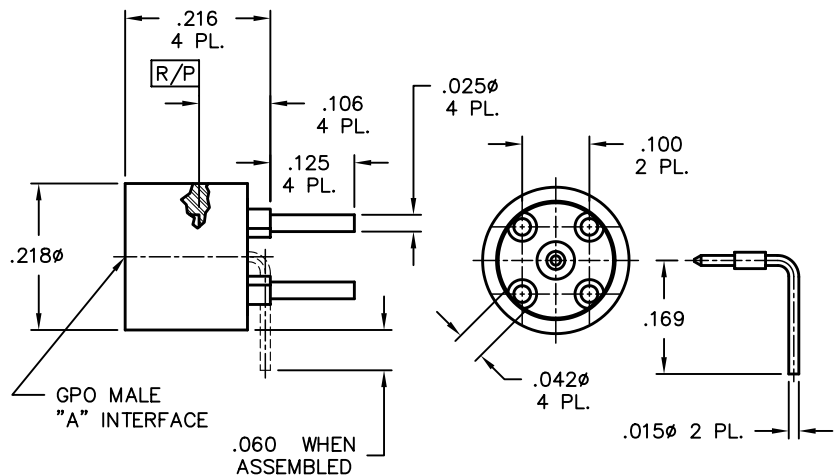

GPO PCB Mounts

Male Limited Detent to PCB with Separate Pin

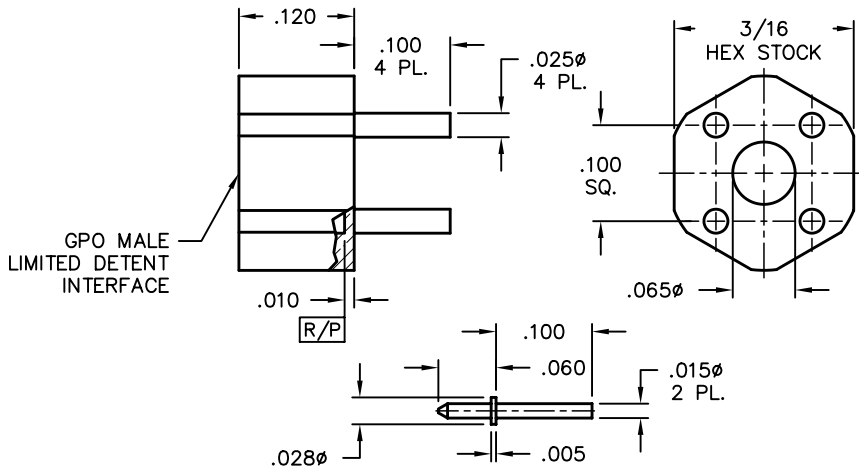

Catalog Number
0119-711-1

VSWR (TYP)
1.30:1 to 20 GHz



Male Straight to PCB

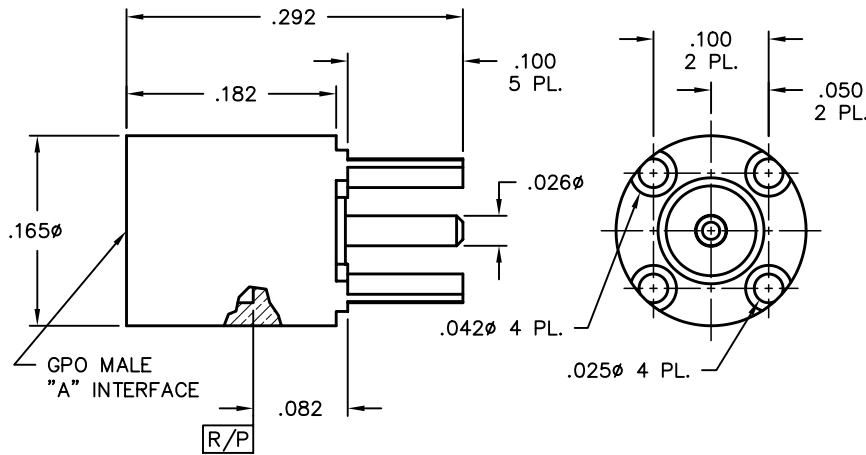

Catalog Number	A
1619-001-1-FD	FD
1619-001-1-LD	LD
1619-001-1-SB	SB

VSWR (TYP)
1.30:1 to 20 GHz



GPO Right Angle PCB Mounts

Male R/A PCB 4 Leg Thru Mount Cap C/C

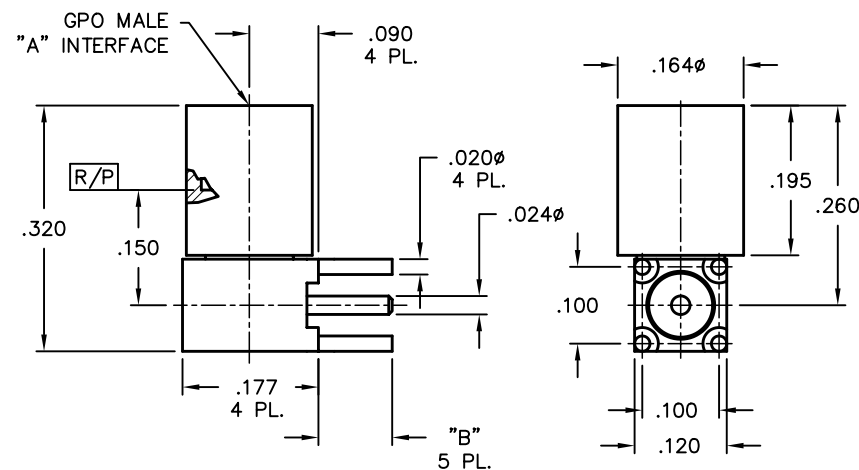

Catalog Number	A	B
A009-P33-01	FD	.096
A009-P34-01	LD	.096
A009-P35-01	SB	.096
A009-P33-03	FD	.140
A009-P34-03	LD	.140
A009-P35-03	SB	.140

VSWR (TYP)
1.35:1 to 20 GHz



GPO Right Angle PCB Mounts

**Male Smooth Bore Catchers Mitt
R/A to PCB**

Catalog Number
0119-397-3-100

VSWR (TYP)
1.35:1 to 20 GHz

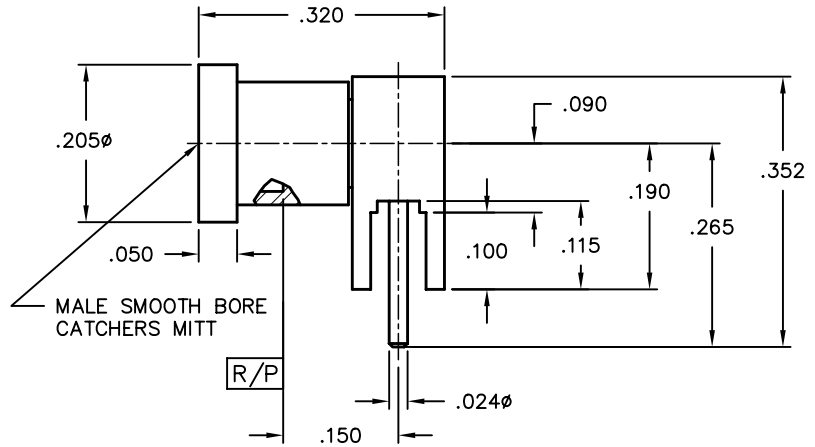

Male Smooth Bore R/A to PCB

Catalog Number
0119-588-1

VSWR (TYP)
1.35:1 to 20 GHz

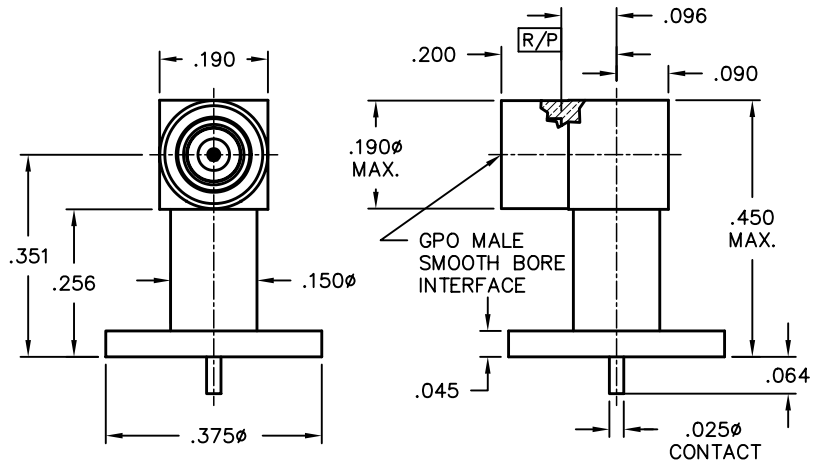

Male Catchers Mitt R/A to PCB

Catalog Number
0119-714-3

VSWR (TYP)
1.35:1 to 20 GHz

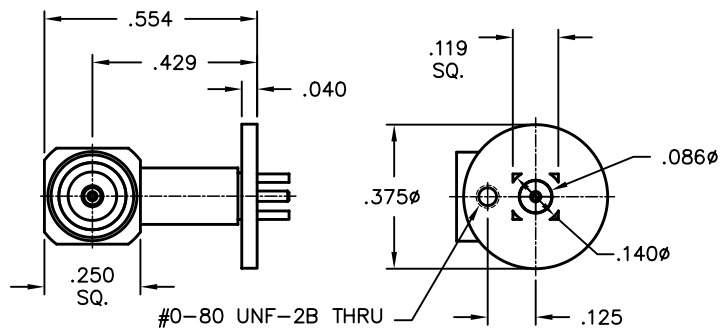

GPO Right Angle PCB Mounts

Male Smooth Bore R/A to PCB with R/A Launch

Catalog Number
0119-720-1
VSWR (TYP)
1.35:1 to 20 GHz

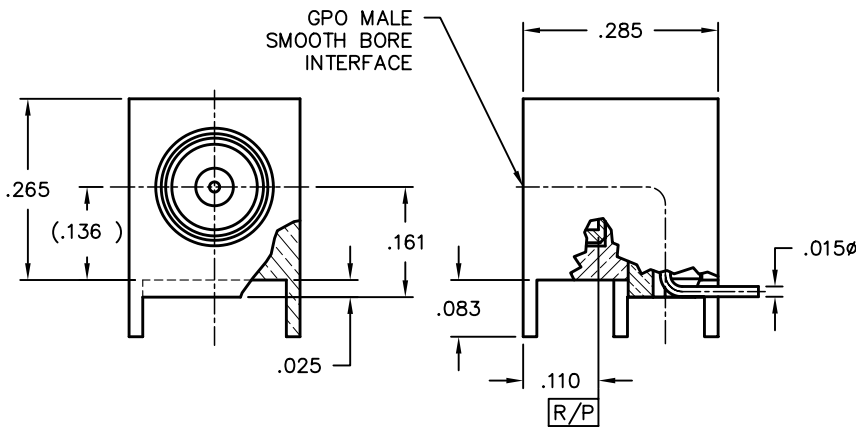

GPO Flange Mounts

Male Flange Mount Shroud No Center Conductor

Catalog Number	A	B	C ϕ	D ϕ
A001-A23-03	FD	.328	.480	.098
A001-A24-03	LD	.328	.480	.098
A001-A25-03	SB	.328	.480	.098
A001-A23-04	FD	.282	.400	.073
A001-A24-04	LD	.282	.400	.073
A001-A25-04	SB	.282	.400	.073
A001-A23-07	FD	.481	.625	.103
A001-A24-07	LD	.481	.625	.103
A001-A25-07	SB	.481	.625	.103

Tools Recommended
A090-A99-11 (For-03 Series)
A090-A99-10 (For-04 Series)
A090-A99-09 (For-07 Series)
A090-A99-03

Assembly Procedure
AP01-009

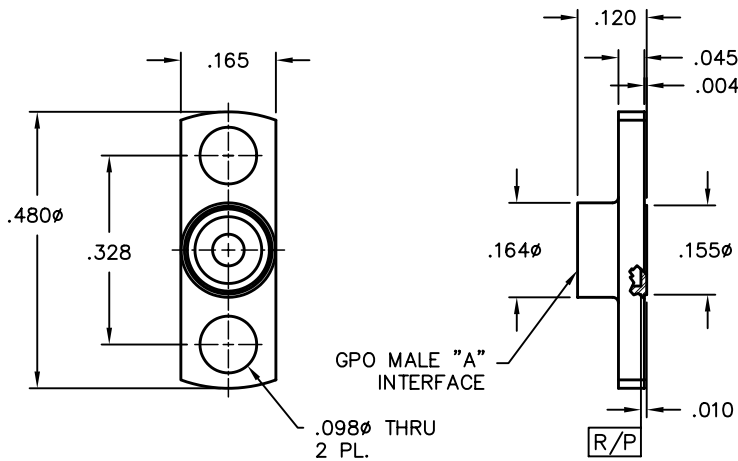

Male Flange Mount Shroud Accepts 0.012 Center Conductor

Catalog Number	A
A001-N33-02	FD
A001-N34-02	LD
A001-N35-02	SB

VSWR (TYP)
1.2:1 to 18 GHz
1.35:1 to 26.5 GHz

Tools Recommended
A090-A99-09

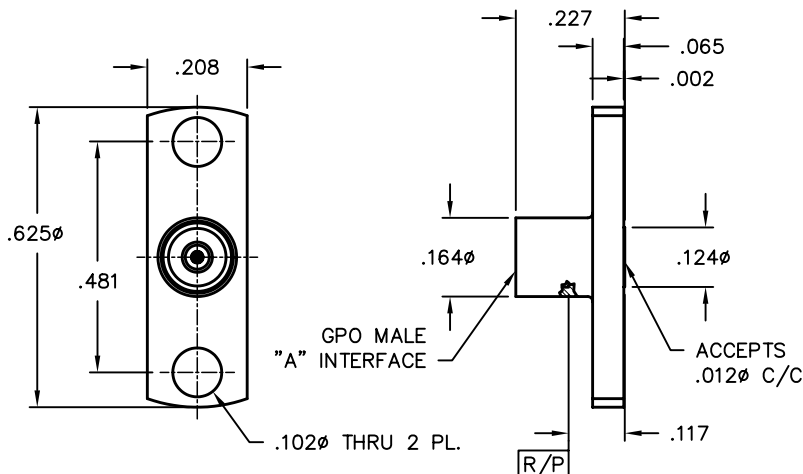

GPO Flange Mounts

Male 2 Hole Flange Mount

Catalog Number	A
A001-N33-05	FD
A001-N34-05	LD
A001-N35-05	SB

VSWR (TYP)
 1.25:1 to 12 GHz
 1.35:1 to 26.5 GHz

Tools Recommended
 A090-A99-09

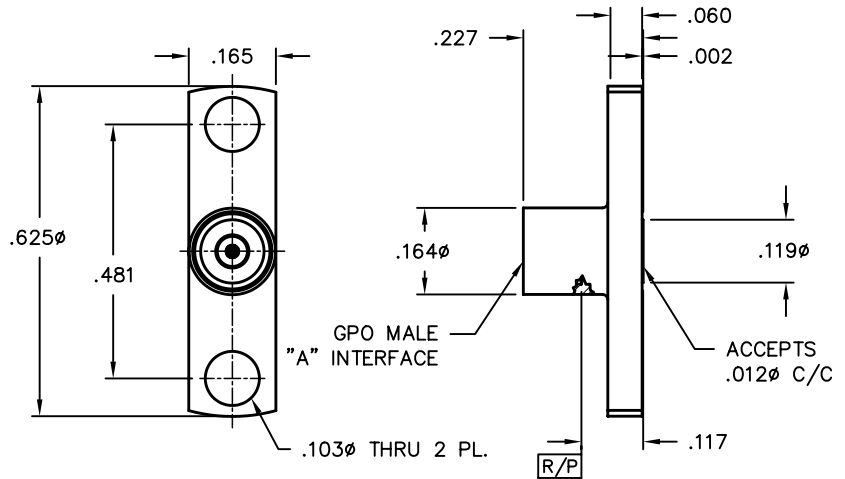

**Male Full Detent 2 Hole Flange Mount
 Straight Terminal**

Catalog Number
0119-441-3

VSWR (TYP)
 1.25:1 to 18 GHz
 1.35:1 to 26.5 GHz

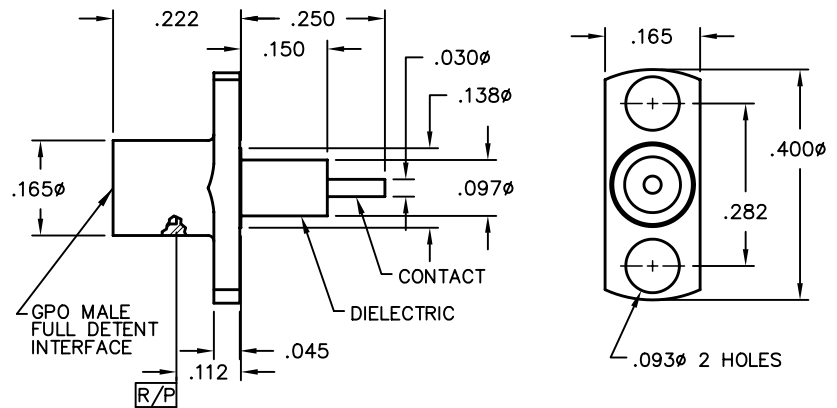

Male R/A Flange Mount

Catalog Number
0119-467-3

VSWR (TYP)
 1.25:1 to 18 GHz
 1.35:1 to 26.5 GHz

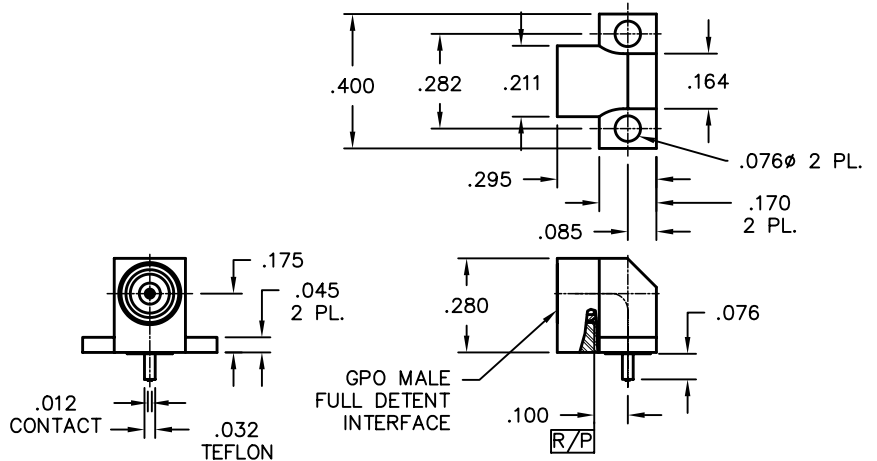

GPO Flange Mounts

**Male Full Detent Flange Mount
Limited Hub 1/2 Hole**

Catalog Number
0119-785-3

Tools Recommended
A090-A99-11
A090-A99-03

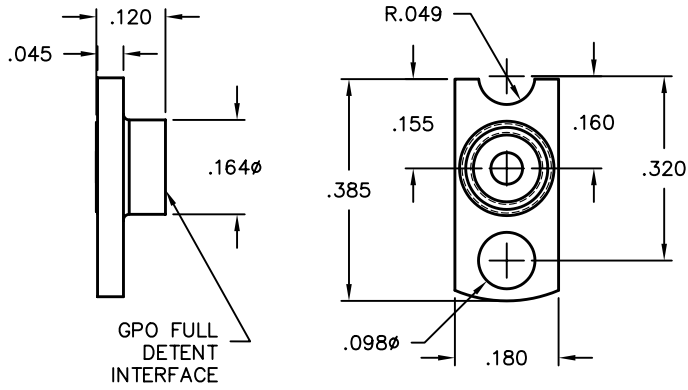

**Male Full Detent Flange Mount
Limited Hub**

Catalog Number
0119-857-3

Tools Recommended
A090-A99-10
A090-A99-03

Assembly Procedure
AP01-009

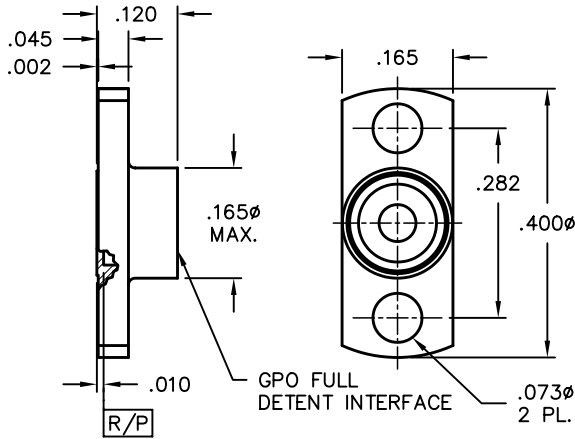

GPO Edge Mounts

Male PCB Edge Mount

Catalog Number A
A010-L13-02 FD
A010-L14-02 LD
A010-L15-02 SB

VSWR (TYP)
1.25:1 to 26.5 GHz

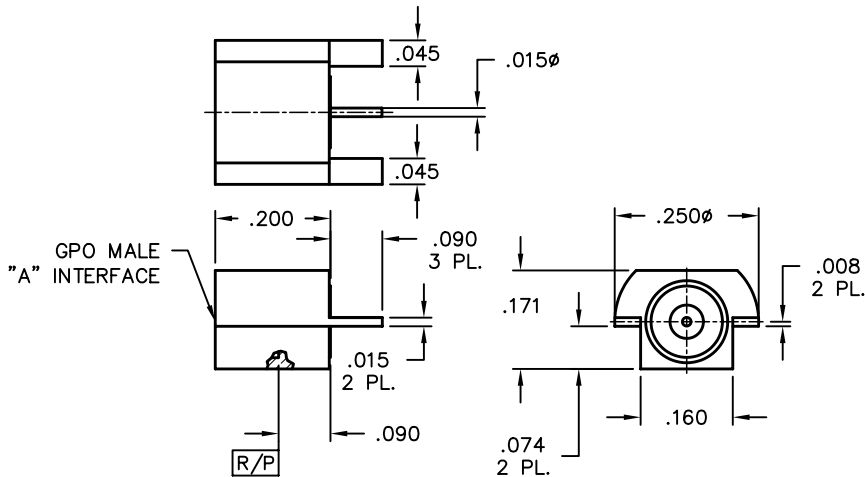

GPO Edge Mounts

Male PCB Edge Mount

Catalog Number	A
A010-L33-01	FD
A010-L34-01	LD
A010-L35-01	SB

VSWR (TYP)
1.25:1 to 26.5 GHz

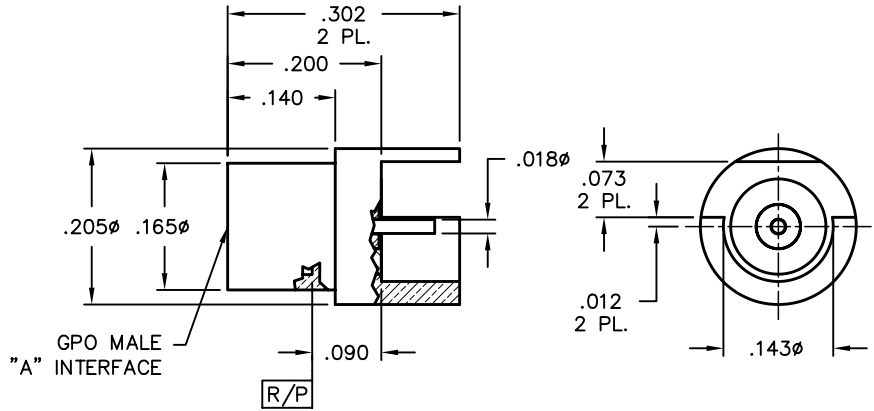

Male PCB Edge Mount

Catalog Number	A
A010-L33-02	FD
A010-L34-02	LD
A010-L35-02	SB

VSWR (TYP)
1.25:1 to 26.5 GHz

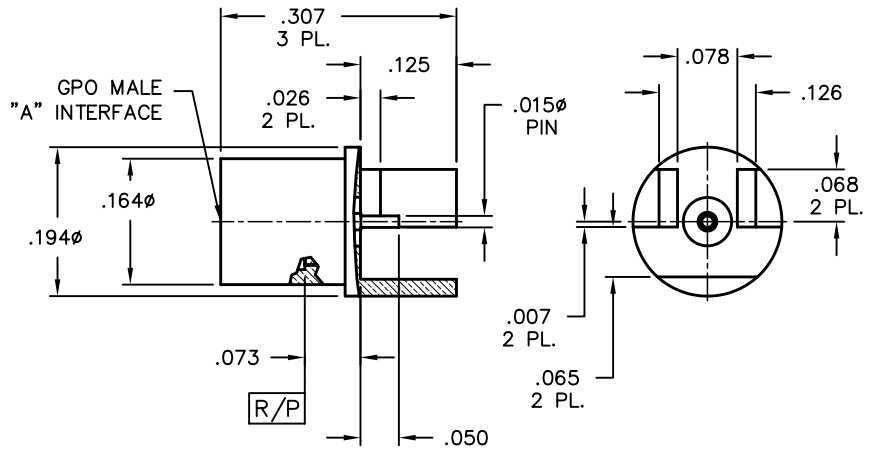

Male PCB Edge Mount with Chassis Mount

Catalog Number	A	B
A010-L33-03	FD	.099
A010-L34-03	LD	.099
A010-L35-03	SB	.099
A010-L33-04	FD	.069
A010-L34-04	LD	.069
A010-L35-04	SB	.069

VSWR (TYP)
1.25:1 to 26.5 GHz

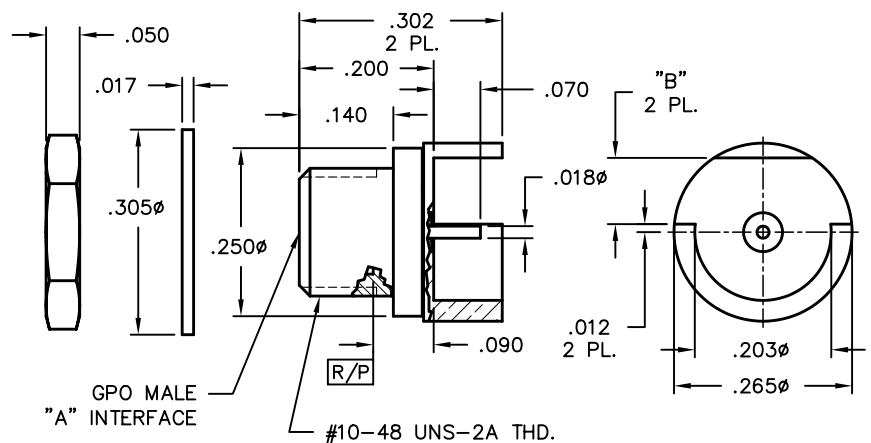

GPO Surface Mounts

Male Solder-on Shroud

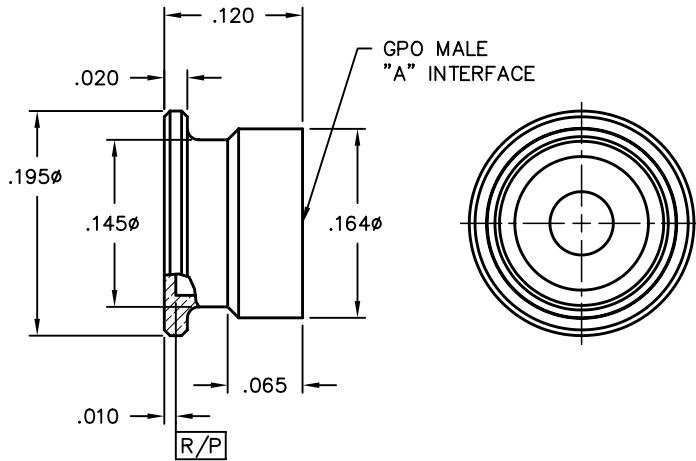

Catalog Number	A
A012-A93-01	FD
A012-A94-01	LD
A012-A95-01	SB



Shroud Solder Mount Smooth Bore Catchers Mitt with Contact

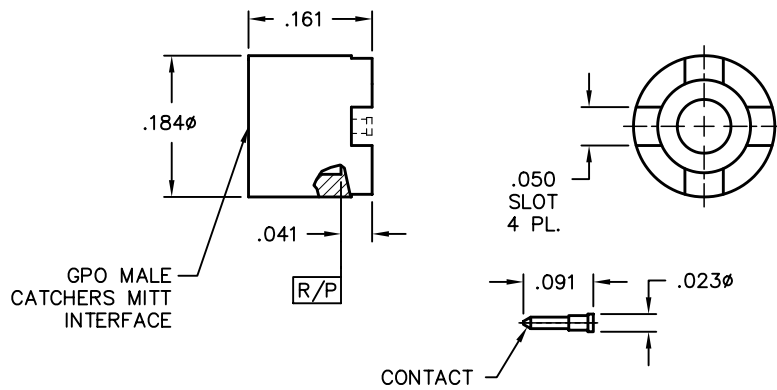

Catalog Number	
A012-L96-01	
VSWR (TYP)	
1.25:1 to 18 GHz	
1.35:1 to 26.5 GHz	



Male PCB Surface Mount

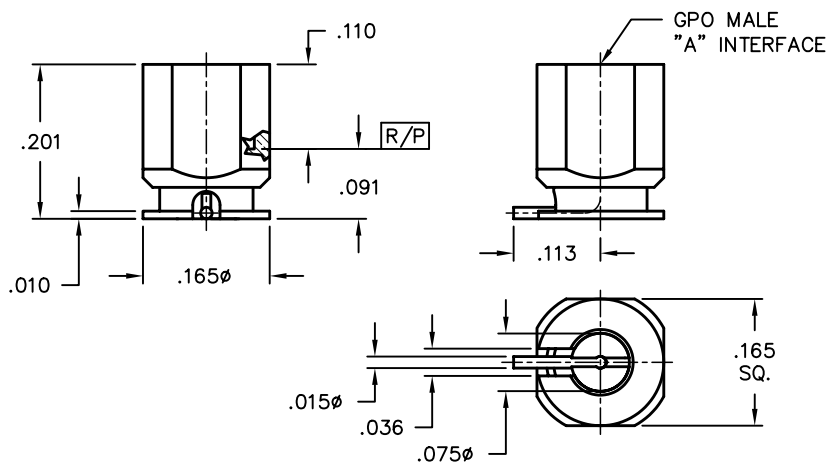

Catalog Number	A
A012-P93-01	FD
A012-P94-01	LD
A012-P95-01	SB
VSWR (TYP)	
1.25:1 to 18 GHz	
1.35:1 to 26.5 GHz	



GPO Surface Mounts

Male PCB 4 Leg Thru Mount R/A C/C

Catalog Number	A
A012-P93-04	FD
A012-P94-04	LD
A012-P95-04	SB

VSWR (TYP)

1.25:1 to 18 GHz
 1.35:1 to 26.5 GHz

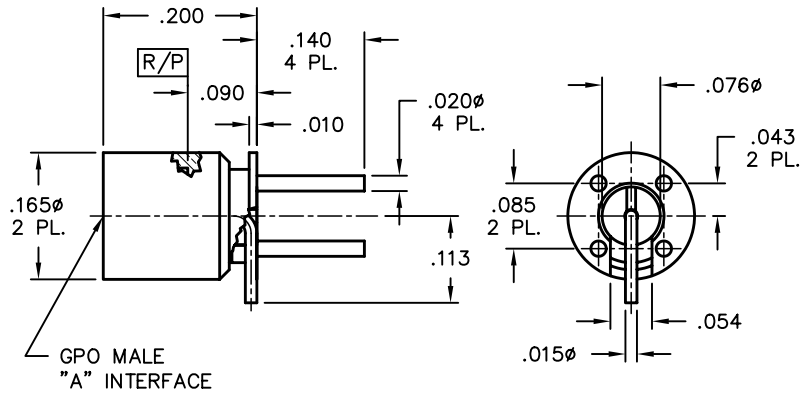

GPO Thread-In Shrouds

Male Thread-in Shroud

Catalog Number	A
A003-A23-01	FD
A003-A24-01	LD
A003-A25-01	SB

Tools Recommended

A090-A99-01

Assembly Procedure

AP01-024

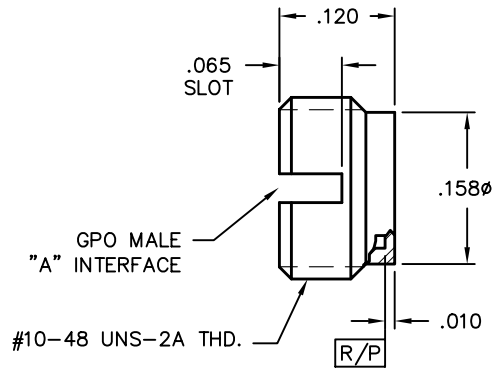

Modified Catchers Mitt Thread-in Shroud

Catalog Number	A
A003-A27-01	

Tools Recommended

A097-A99-03

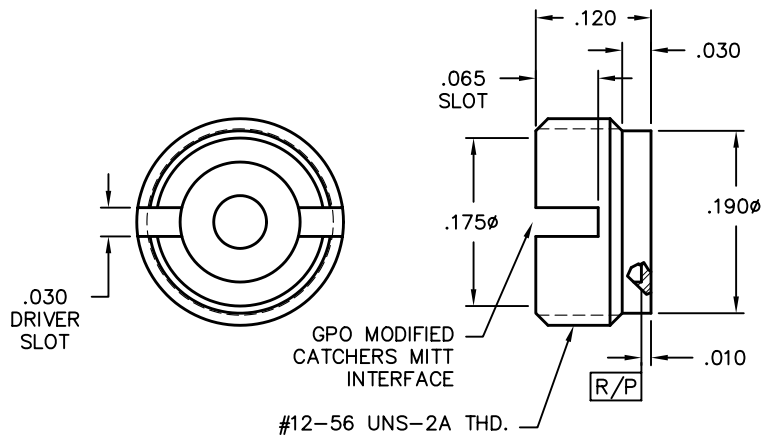

GPO Thread-In Shrouds

Female Thread-in Waveguide Launch

Catalog Number

A003-L11-01

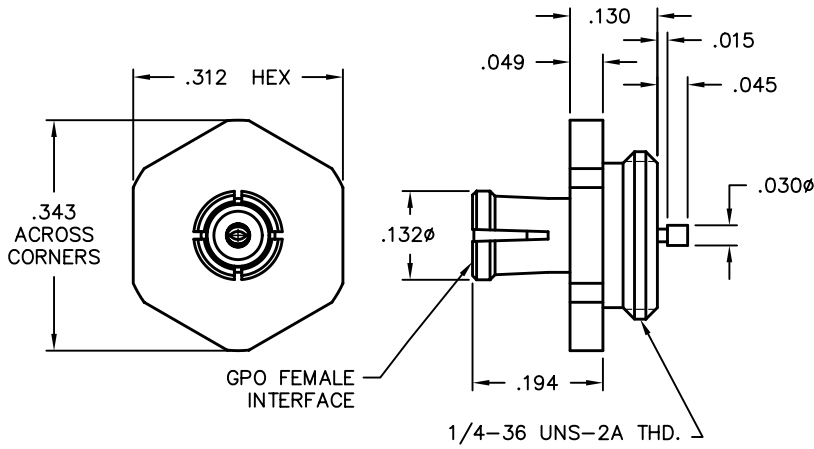

Male Thread-in Straight Terminal

Catalog Number

A

Tools Recommended

A003-L33-01

FD

A097-A99-01 for FD

A003-L34-01

LD

A097-A99-02 for LD

A003-L35-01

SB

A097-A99-03 for SB

VSWR (TYP)

1.25:1 to 18 GHz

1.35:1 to 26.5 GHz

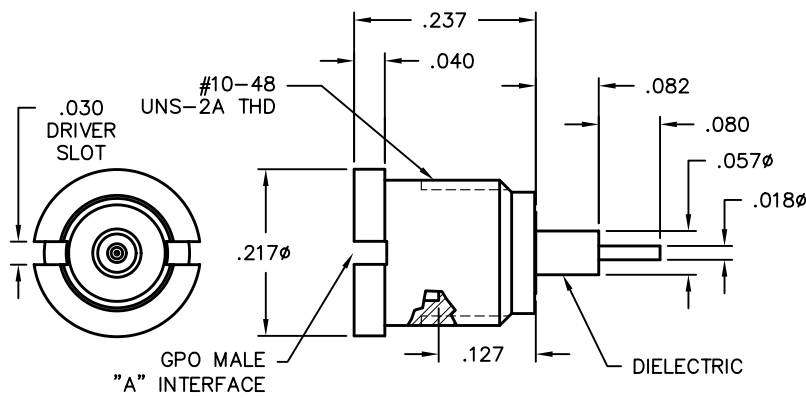

Male Thread-in Shroud 0.018 Pin Contact

Catalog Number

A

Tools Recommended

A003-L33-02

FD

A097-A99-01 for FD

A003-L34-02

LD

A097-A99-02 for LD

A003-L35-02

SB

A097-A99-03 for SB

VSWR (TYP)

1.25:1 to 18 GHz

1.35:1 to 26.5 GHz

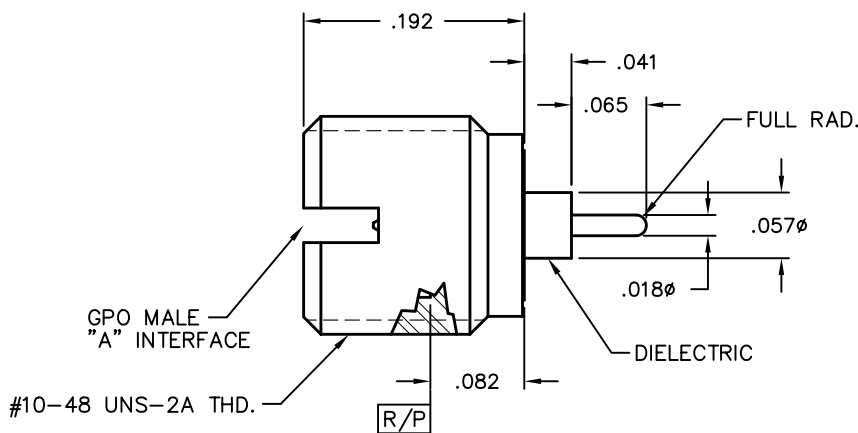

GPO Thread-In Shrouds

Male Thread-in Shroud Accepts 0.012ø Pin

Catalog Number	A	Tools Recommended
A003-N33-01	FD	A097-A99-01 for FD
A003-N34-01	LD	A097-A99-02 for LD
A003-N35-01	SB	A097-A99-03 for SB
		A097-A99-07
VSWR (TYP)		
1.25:1 to 18 GHz		Assembly Procedure
1.35:1 to 26.5 GHz		AP01-104

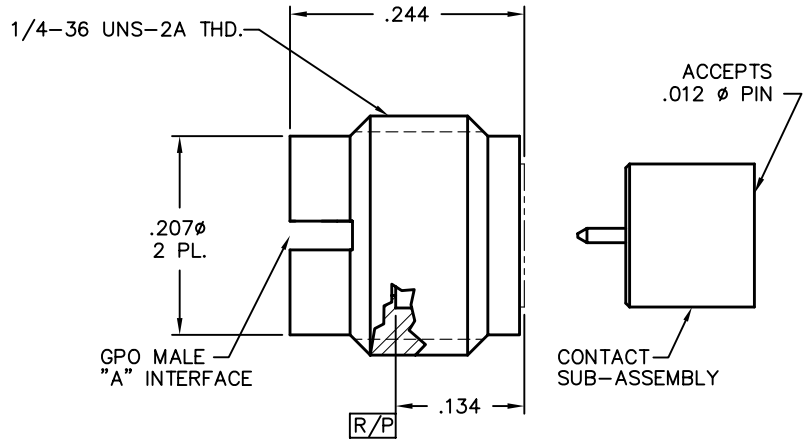

Male Thread-in Shroud Accepts 0.012ø Pin

Catalog Number	A	Tools Recommended
A003-N33-02	FD	A097-A99-01 for FD
A003-N34-02	LD	A097-A99-02 for LD
A003-N35-02	SB	A097-A99-03 for SB
		A097-A99-07
VSWR (TYP)		
1.25:1 to 18 GHz		
1.35:1 to 26.5 GHz		

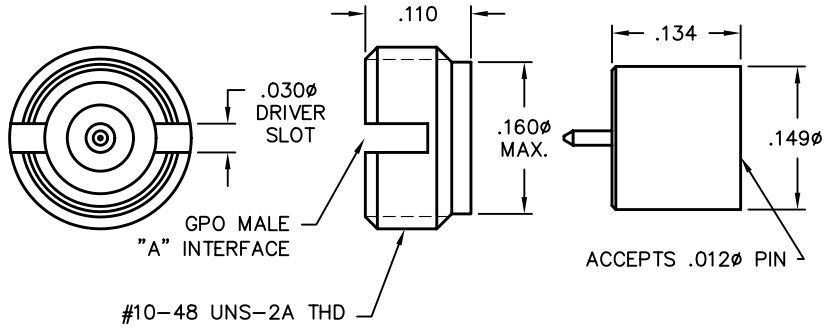

GPO Female Thread-in

Catalog Number
0119-228-1
VSWR (TYP)
1.25:1 to 18 GHz
1.35:1 to 26.5 GHz

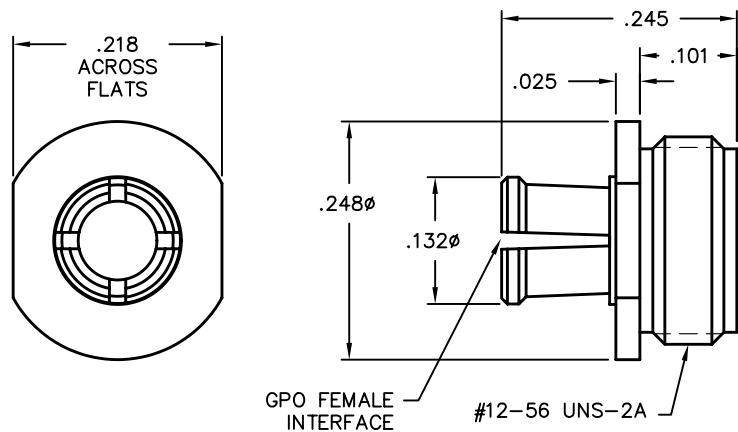

GPO Thread-In Shrouds

Male Thread-in Non-hermetic Straight Terminal

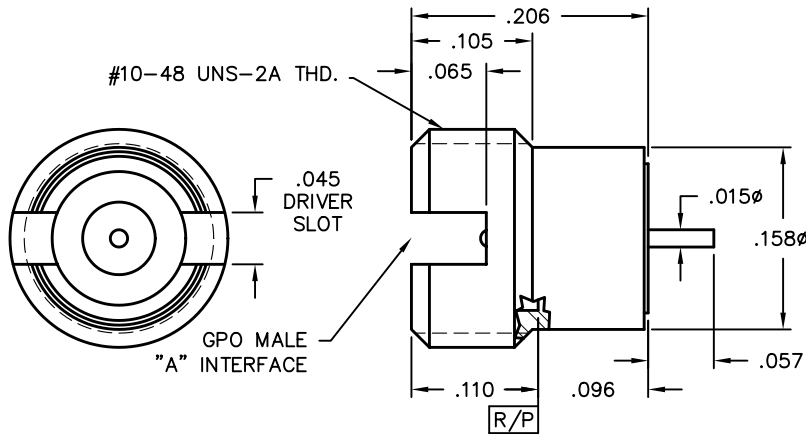

Catalog Number	A	Tools Recommended
0119-258-3-FD	FD	A090-A99-01 for FD
0119-258-3-LD	LD	A090-A99-02 for LD
0119-258-3-SB	SB	A090-A99-03 for SB

VSWR (TYP)
 1.25:1 to 18 GHz
 1.35:1 to 26.5 GHz



Male Catchers Mitt to Straight Terminal

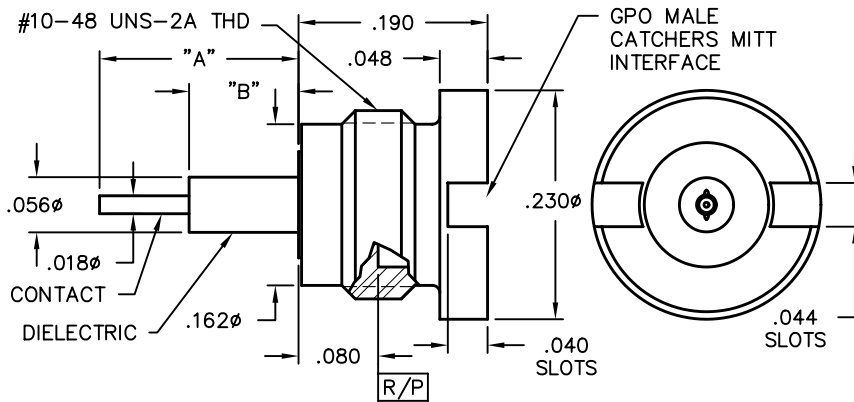

Catalog Number	A	B
0119-424-3-1	.067-.073	.040
0119-424-3-2	.097-.103	.040
0119-424-3-3	.200	.110
0119-424-3-4	.350	.260

VSWR (TYP)
 1.35:1 to 18 GHz
 1.45:1 to 26.5 GHz

Tools Recommended
 A090-A99-03

Assembly Procedure
 AP01-057



1. CONTACT ROTATIONALLY CAPTIVATED IN RELATION TO OUTER HOUSING.

GPO Press-In Shrouds

Male Press-in Shroud

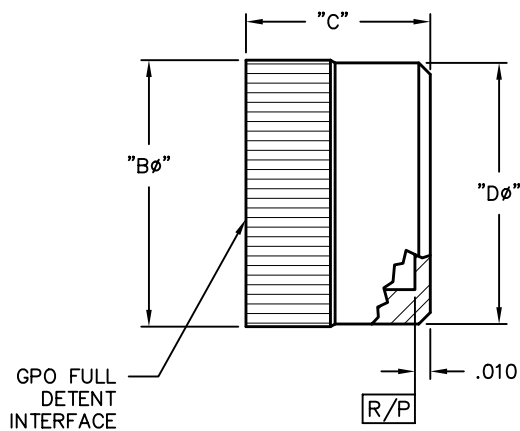

Catalog Number	A	B ϕ	C	D ϕ
A005-A23-01	FD	.174	.120	.170
A005-A24-01	LD	.174	.120	.170
A005-A25-01	SB	.174	.120	.170
A005-A23-02	FD	.154	.080	.143
A005-A24-02	LD	.154	.080	.143
A005-A25-02	SB	.154	.080	.143

Tools Recommended
 A090-A99-08



GPO Press-In Shrouds

Male Press-in Straight Terminal

Catalog Number	A	Tools Recommended
A005-L33-01	FD	A090-A99-08
A005-L34-01	LD	Assembly Procedure
A005-L35-01	SD	AP01-070

VSWR (TYP)

1.25:1 to 18 GHz
1.35:1 to 26.5 GHz

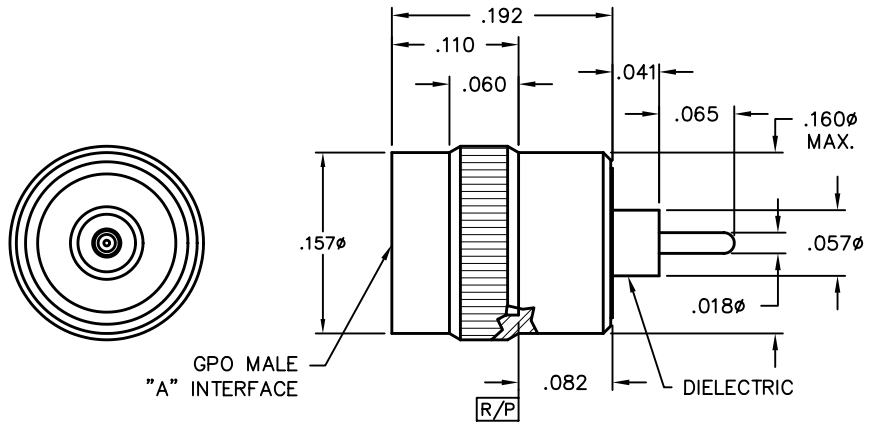

GPO Hermetic Shrouds

Male Hermetic Shroud Full Shroud Full Body

Catalog Number	A	L Lengths
A007-L43-01-TAB-X	FD	.030/.050/.070/.090
A007-L44-01-TAB-X	LD	.030/.050/.070/.090
A007-L45-01-TAB-X	SB	.030/.050/.070/.090

VSWR (TYP)

1.25:1 to 18 GHz
1.35:1 to 26.5 GHz

TAB = $L \times 10^3$ inches

X = Customer defined. Straight (S) or Radius (R) cut.

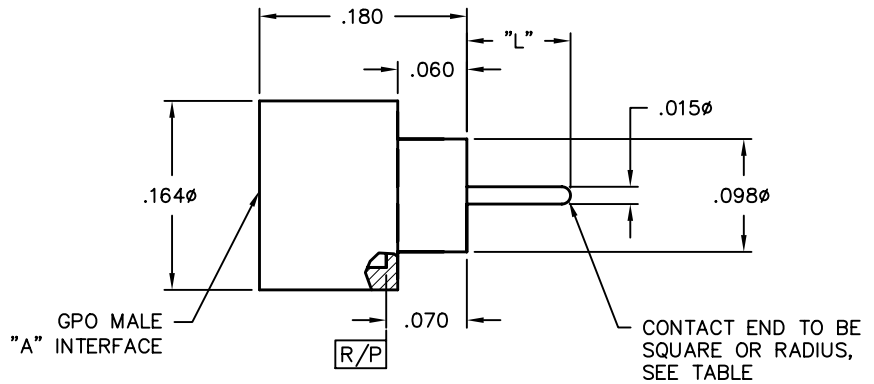

Male Hermetic Shroud Half Shroud Full Body

Catalog Number	A	L Lengths
A007-L43-02-TAB-X	FD	.030/.050/.070/.090
A007-L44-02-TAB-X	LD	.030/.050/.070/.090
A007-L45-02-TAB-X	SB	.030/.050/.070/.090

VSWR (TYP)

1.25:1 to 18 GHz
1.35:1 to 26.5 GHz

TAB = $L \times 10^3$ inches

X = Customer defined. Straight (S) or Radius (R) cut.

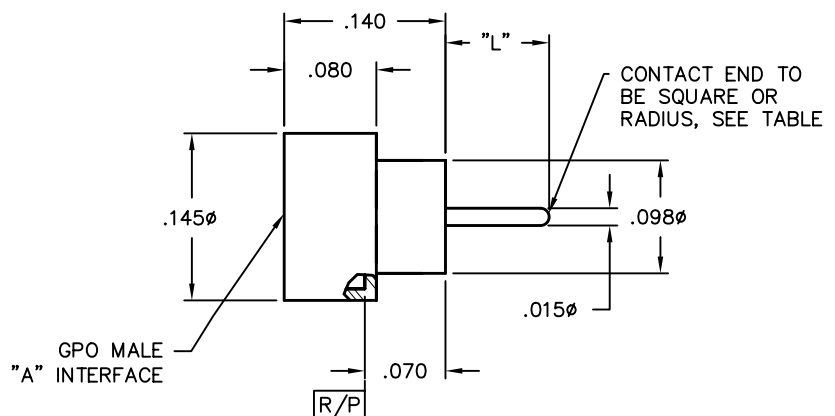

GPO Hermetic Shrouds

Male Hermetic Shroud Full Shroud Short Body

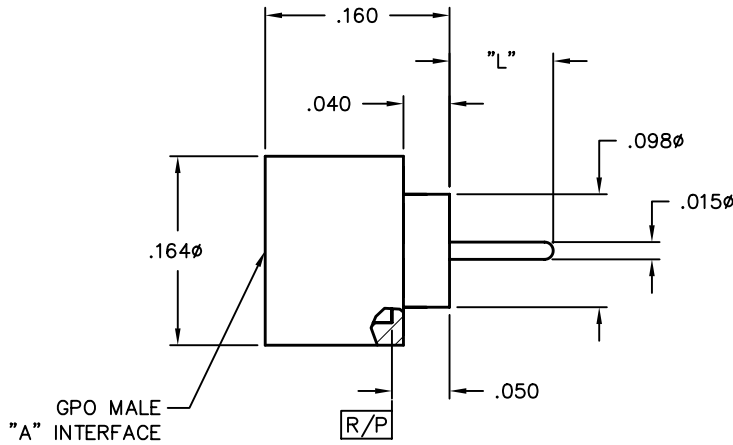

Catalog Number	A	L Lengths
A007-L43-03-TAB-X	FD	.030/.050/.070/.090
A007-L44-03-TAB-X	LD	.030/.050/.070/.090
A007-L45-03-TAB-X	SB	.030/.050/.070/.090

VSWR (TYP)

1.25:1 to 18 GHz
1.35:1 to 26.5 GHz

TAB = $L \times 10^3$ inches

X = Customer defined. Straight (S) or Radius (R) cut.



Male Hermetic Shroud Half Shroud Short Body

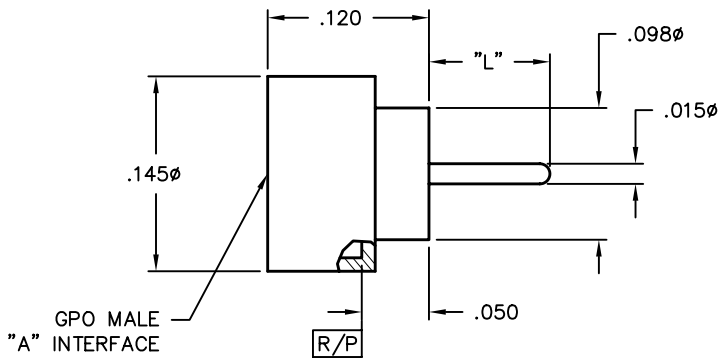

Catalog Number	A	L Lengths
A007-L43-04-TAB-X	FD	.030/.050/.070/.090
A007-L44-04-TAB-X	LD	.030/.050/.070/.090
A007-L45-04-TAB-X	SB	.030/.050/.070/.090

VSWR (TYP)

1.25:1 to 18 GHz
1.35:1 to 26.5 GHz

TAB = $L \times 10^3$ inches

X = Customer defined. Straight (S) or Radius (R) cut.



Male Full Detent Thread-in Shroud Straight Terminal

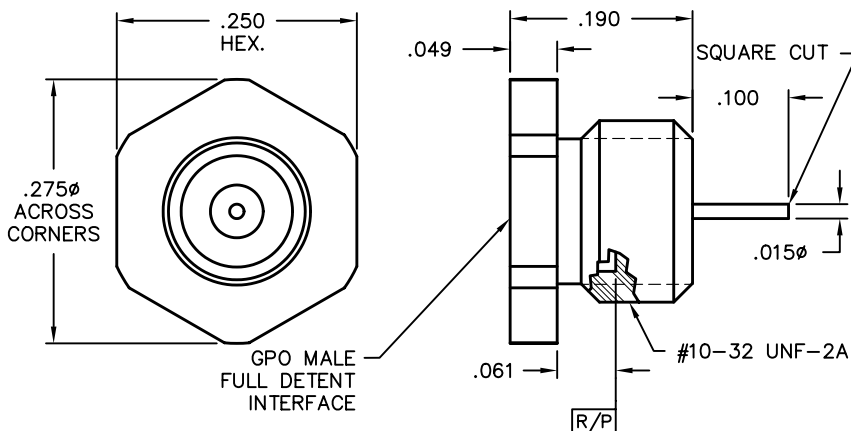

Catalog Number

A007-L43-14

VSWR (TYP)

1.25:1 to 18 GHz
1.35:1 to 26.5 GHz



GPO Hermetic Shrouds

Male Solder-in Hermetic Shroud

Catalog Number	A
0119-248-1-FD	FD
0119-248-1-LD	LD
0119-248-1-SB	SB
0119-248-1-CM	CM

VSWR (TYP)

1.25:1 to 18 GHz
1.35:1 to 26.5 GHz

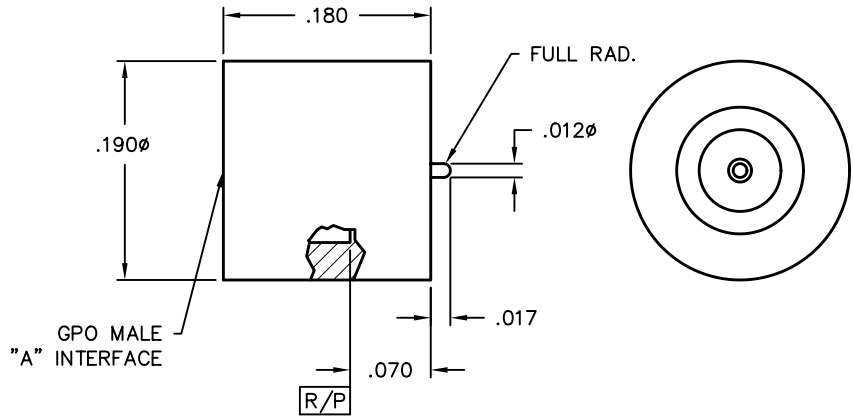

Male Solder-in Hermetic Shroud with Tin Solder Dipping

Catalog Number	A
0119-248-1-FD-T	FD
0119-248-1-LD-T	LD
0119-248-1-SB-T	SB
0119-248-1-CM-T	CM

VSWR (TYP)

1.25:1 to 18 GHz
1.35:1 to 26.5 GHz

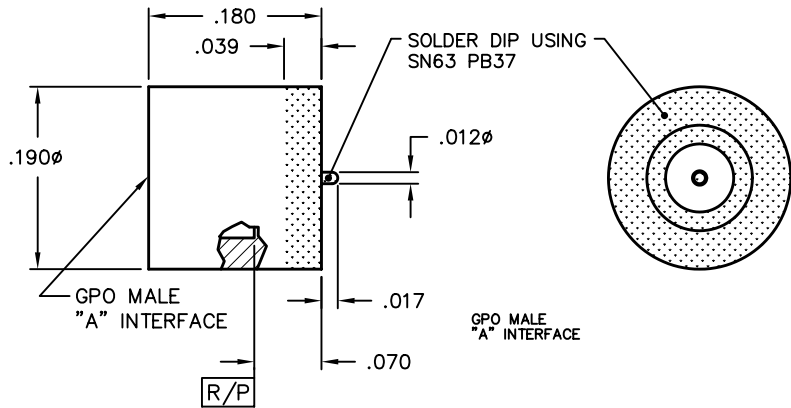

GPO Loads

Female 50 Ohm Load

Catalog Number	Grade
A055-A11-01	TEST GRADE
A055-A11-02	FIELD GRADE

VSWR (TYP)

TEST GRADE 1.20:1 to 26.5 GHz
FIELD GRADE 1.25:1 to 26.5 GHz

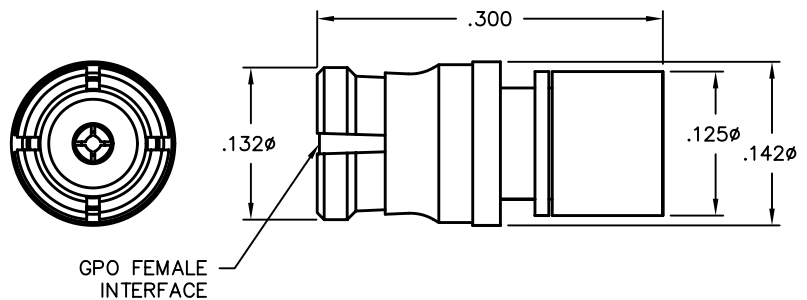

GPO Loads

Male 50 Ohm Load

Catalog Number	A	Grade
A055-A14-01	LD	TEST GRADE
A055-A15-01	SB	TEST GRADE
A055-A14-02	LD	FIELD GRADE
A055-A15-02	SB	FIELD GRADE

VSWR (TYP)

TEST GRADE 1.20:1 to 18 GHz, 1.40:1 to 26.5 GHz
 FIELD GRADE 1.30:1 to 18 GHz, 1.50:1 to 26.5 GHz

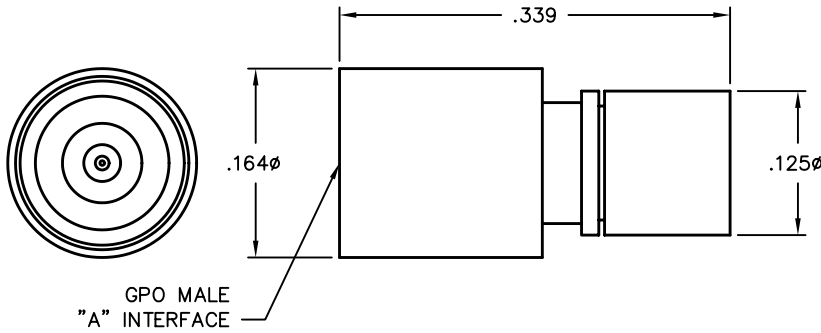

GPO Hermetic Seals

50 Ohm Hermetic Seal

Catalog Number	A
Y007-L42-03	.050
Y007-L42-02	.125
Y007-L42-04	.200

VSWR (TYP)

1.15:1 to 26.5 GHz

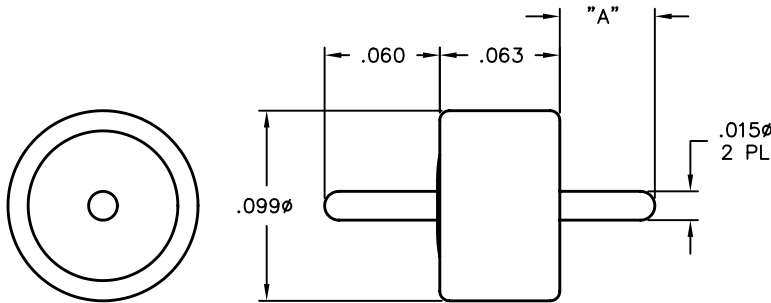

GPO Pins

Catalog Number

Y071-L92-02

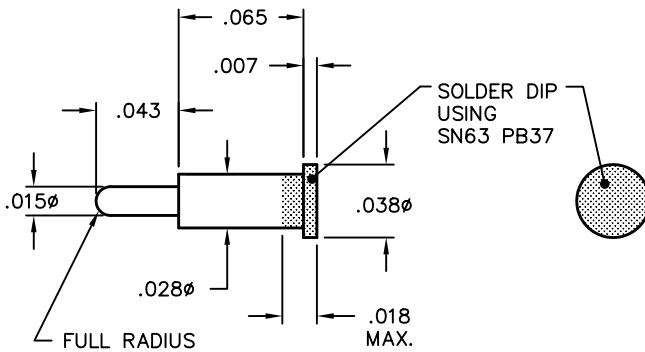

GPO Pins

Catalog Number
Y071-L92-03

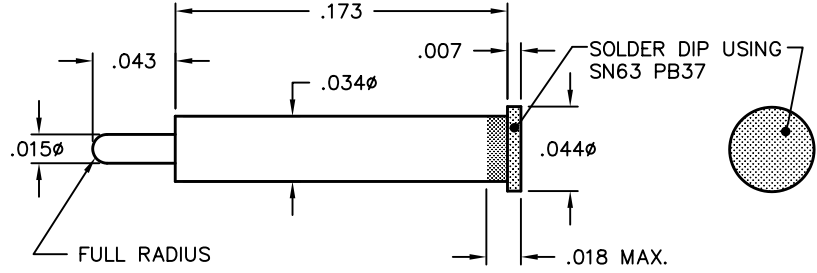

Catalog Number
Y071-L92-04

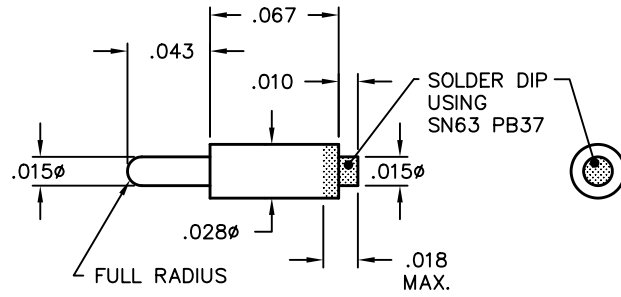

GPO Multiposition Blocks

GPO Male Full Detent 4-Position Field Replacement 0.086 Cable Connector

Catalog Number

A033-B93-02-4

Mating Block:

A033-B95-02-4

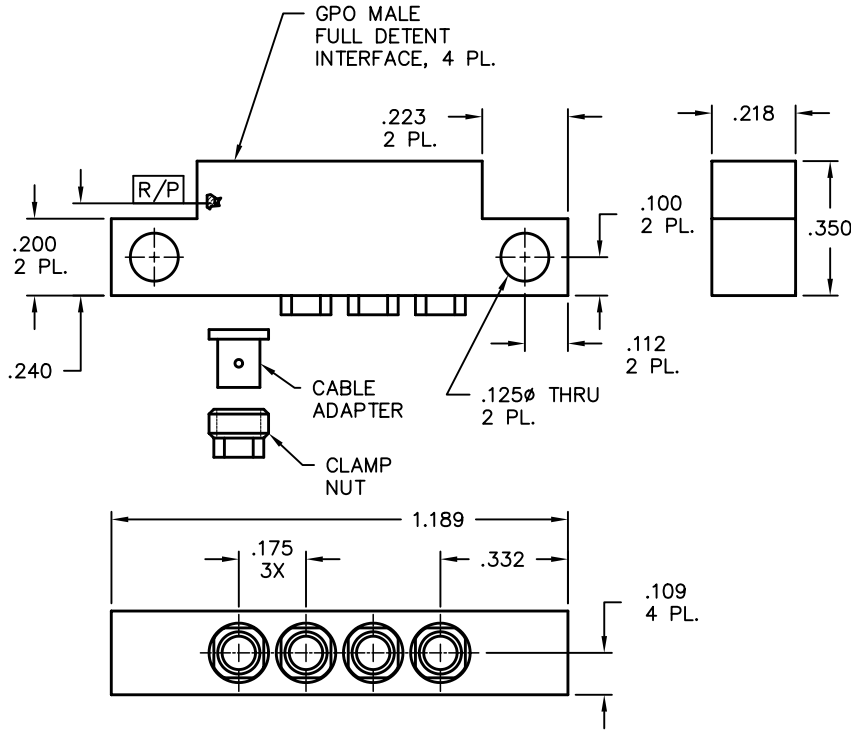

GPO Male Smooth Bore 4-Position Surface Mount PCB Connector

Catalog Number

A036-P95-01-4

Mating Block:

A036-P93-01-4

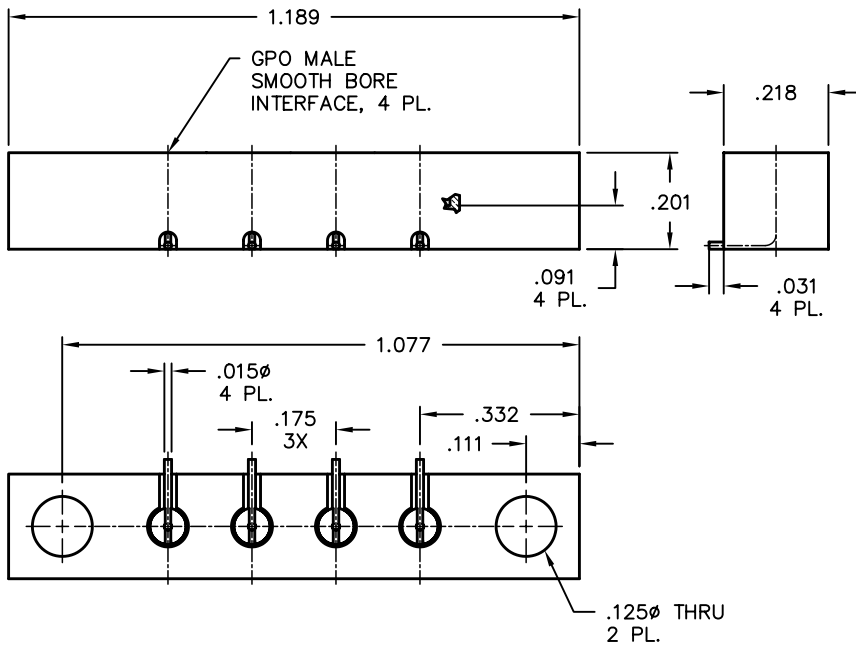

GPO Multiposition Blocks

**Male 2-Position Full Detent Connector
for 0.086 S/R Cable**

Catalog Number
A033-D53-01

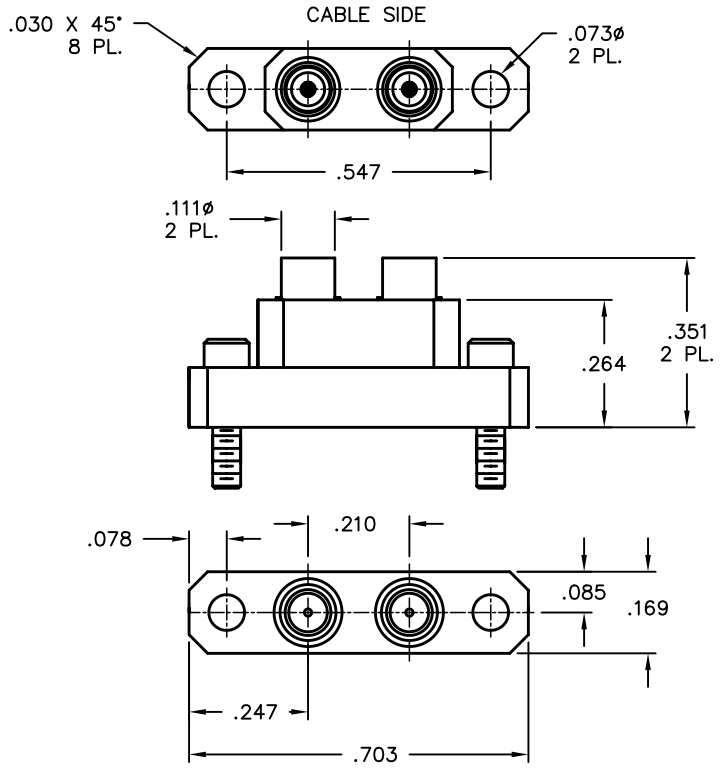

GPPO Products

- Center-to-center spacing of 0.140" available for increased package density
- Frequency from DC to 65 GHz
- Designed to accommodate both radial and axial misalignment with negligible VSWR change
- Adapters available to SMA, 2.4mm and 1.85mm



GPPO® Specifications

General Characteristics

Impedance	50 ohms nominal
Frequency range	DC to 65 GHz
Temperature range	-65°C thru 165°C

Electrical Characteristics

VSWR	1.10:1 to 26.5 GHz typical; 1.30 : 1 typical to 50 GHz
Insertion loss	.04 √f (GHz)
DWV@ Sea Level:	325 Vrms
Insulation resistance	5,000 megohms min.
Contact resistance	
Outer conductor	2 milliohms max.
Inner conductor	6 milliohms max.
RF leakage	-80 dB (typical mated pair)

Mechanical Characteristics

Mate/Demate Cycles	Full Detent - 100min.; Smooth Bore - 500min.
Force to engage/disengage	FD - 4.5lbs.typ./6.5lbs.typ.; SB - 2.5lbs.typ./1.5lbs.typ.
Tolerated misalignment	
Radial	+/- 0.010
Axial	0.010 (flush to 0.010 from the reference plane)

Environmental Characteristics

Thermal Shock	MIL-STD-202, Method 107, Condition B
Salt Spray	MIL-STD-202, Method 101
Vibration	MIL-STD-202, Method 204
Shock	MIL-STD-202, Method 213, Condition I
Moisture resistance	MIL-STD-202, Method 106, except Step 7B

Materials (typical)

Bodies	Beryllium Copper per ASTM B196 and or/ASTM B197
Outer contacts	Beryllium Copper per ASTM B196 and or/ASTM B197
Center contacts	Beryllium Copper per ASTM B196 and or/ASTM B197
Insulators	PTFE Fluorocarbon per ASTM D1710
Springs	17-7 Stainless Steel per ASTM A313-95A

Finish (typical)

Bodies	Gold plated per MIL-G-45204, Type I, Grade C, Class 1, Over Nickel Plate per SAE AMS-QQ-N-290
Contacts	Gold plated per MIL-G-45204, Type I, Grade C, Class 1, Over Nickel Plate per SAE AMS-QQ-N-290

GPPO Blindmate Interconnects

**Female Blindmate Interconnect
(0.166 Long)**

Catalog Number

B1B1-0001-05

VSWR (TYP)

1.15:1 to 18 GHz

1.35:1 to 40 GHz

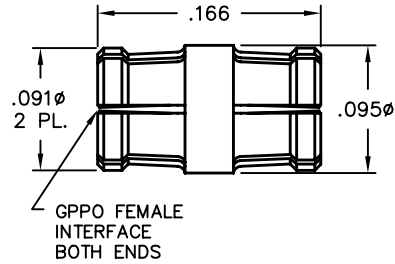

Female Blindmate Interconnect

Catalog Number

A

B1B1-0001-01 0.210

B1B1-0001-02 0.500

B1B1-0001-03 0.327

B1B1-0001-07 0.260

B1B1-0001-08 0.349

B1B1-0001-09 0.278

VSWR (TYP)

1.15:1 to 18 GHz

1.25:1 to 40 GHz

1.35:1 to 65 GHz

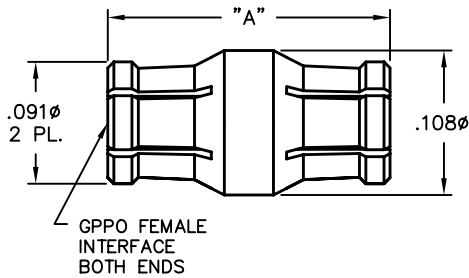

**Female Blindmate Interconnect
with Centering Ring**

Catalog Number

0118-921-1

VSWR (TYP)

1.10:1 to 18 GHz

1.20:1 to 40 GHz

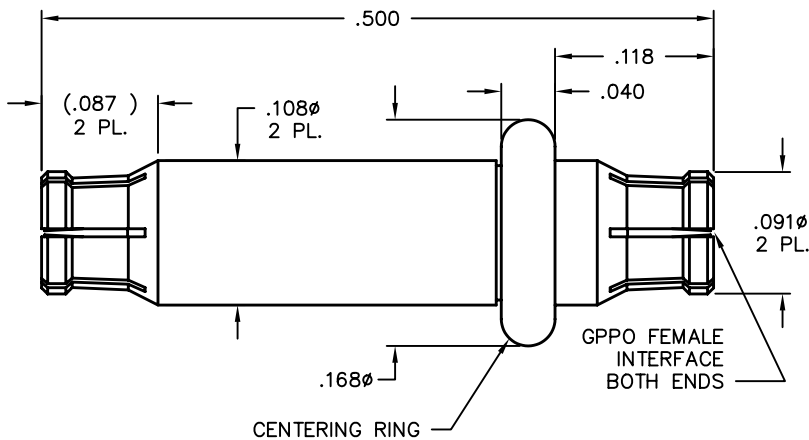

GPPO Blindmate Interconnects

**Female Spring Loaded Bullet
0.412 Relaxed Length**

Catalog Number

B1B1-0001-10

Compression Length: .382

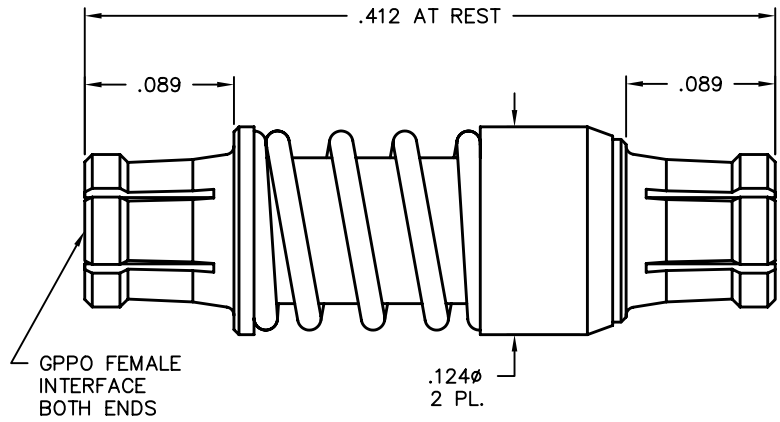

**Spring Loaded Bullet
0.646 Relaxed Length**

Catalog Number

B1B1-0001-11

Compression Length: .591

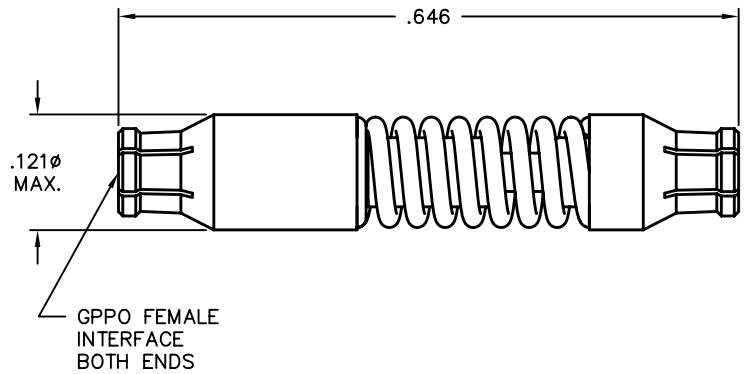

GPPO Cable Connectors

Female Straight to 0.047 S/R Cable

Catalog Number

B014-B11-01

Tools Recommended

B096-A93-01

VSWR (TYP)

1.10:1 to 26.5 GHz

A096-A99-04

L096-A99-02

1.20:1 to 40 GHz

Assembly Procedure

AP01-133

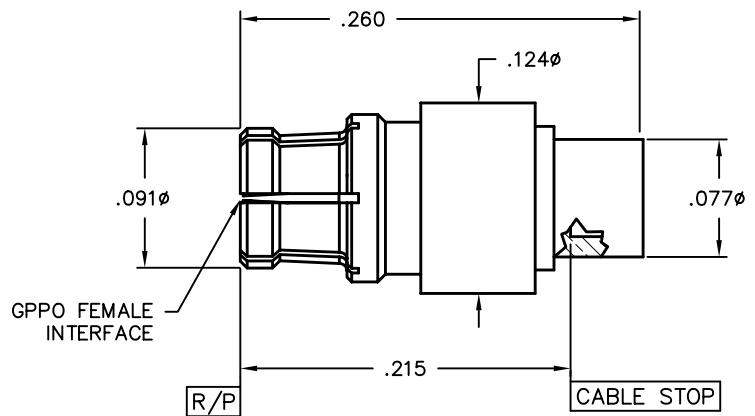

GPPO Cable Connectors

Female Straight to 0.086 S/R Cable

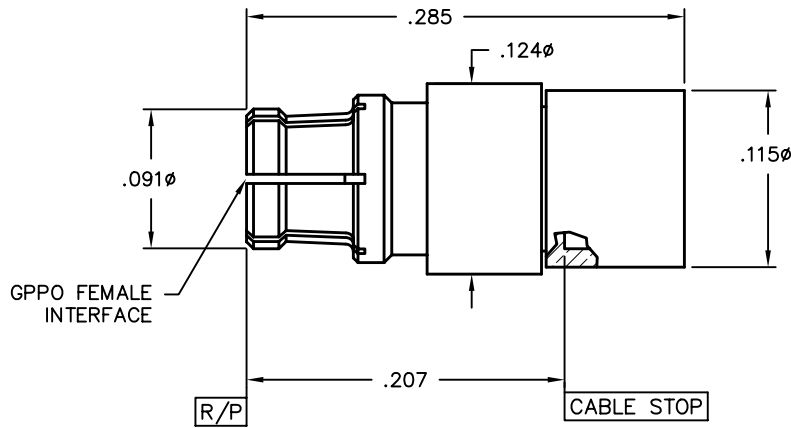

Catalog Number	Tools Recommended
B014-D11-01	B096-A93-01
VSWR (TYP)	A096-A99-04
1.10:1 to 26.5 GHz	L096-A99-01
1.25:1 to 40 GHz	Assembly Procedure
	AP01-148



Female Straight to M1049 (0.080) Flex Cable

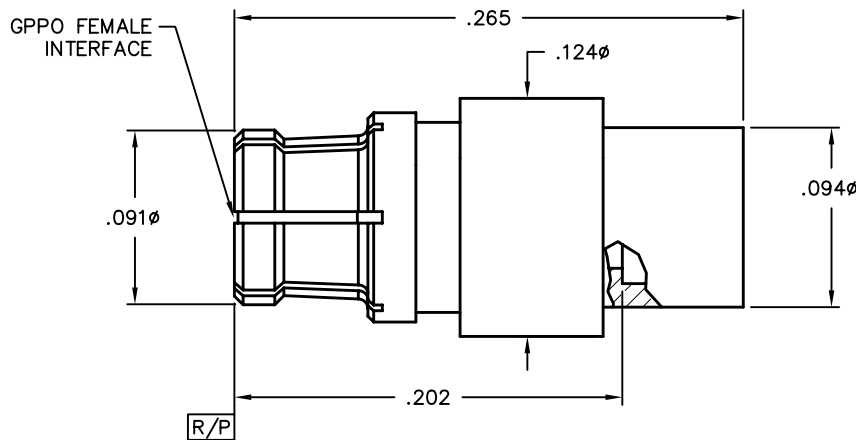

Catalog Number	Assembly Procedure
B014-K11-01	AP01-108
Tools Recommended	
B096-A93-01	
A096-A99-04	
L096-A99-01	



Female R/A to 0.047 S/R Cable

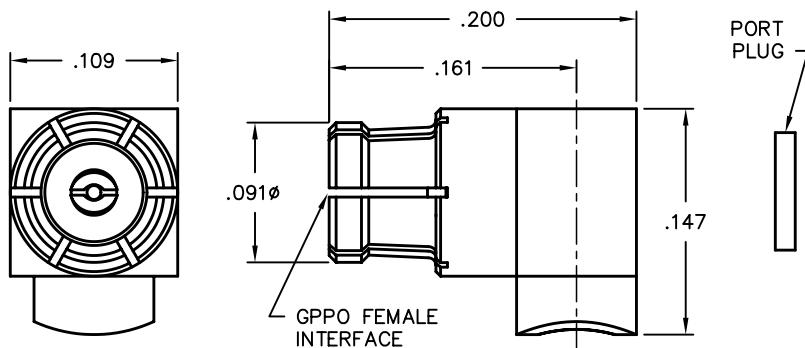

Catalog Number	Tools Recommended
B015-B11-01	B096-A93-01
VSWR	L096-A99-02
1.10:1 to 10 GHz	A096-A99-09
1.25:1 to 20 GHz	Assembly Procedure
	AP01-080



GPPO Cable Connectors

Female Swept R/A to 0.047 S/R Cable

Catalog Number	Tools Recommended
B015-B11-02	B096-A93-01
VSWR	A096-A99-10
1.15:1 to 18 GHz	L096-A99-02
1.30:1 to 26.5 GHz	Assembly Procedure
	AP01-076

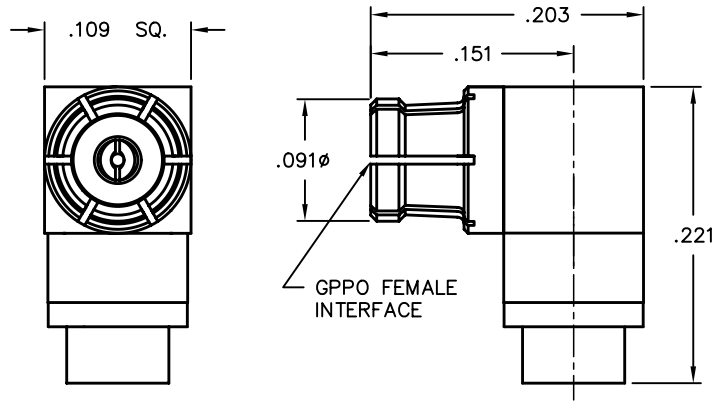

Female R/A to 0.047 S/R Cable

Catalog Number	Tools Recommended
B015-B11-04	B096-A93-01
VSWR	A096-A99-09
1.10:1 to 10 GHz	L096-A99-02
1.30:1 to 15 GHz	Assembly Procedure
	AP01-150

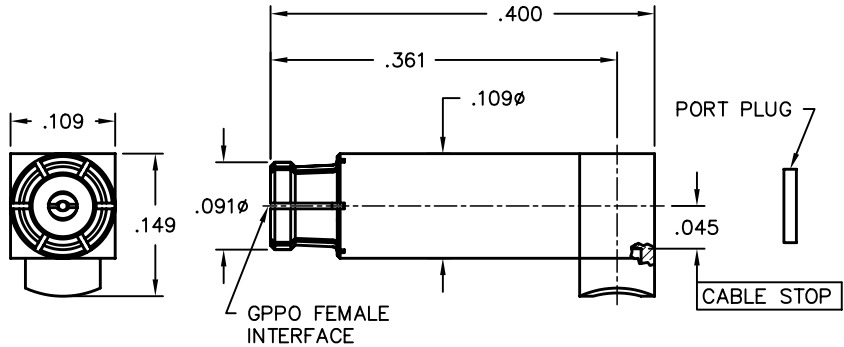

Female R/A to 0.047 S/R Cable

Catalog Number	Tools Recommended
0118-927-1	B096-A93-01
VSWR	A096-A99-10
1.10:1 to 18 GHz	L096-A99-02
1.20:1 to 26.5 GHz	Assembly Procedure
	AP01-122

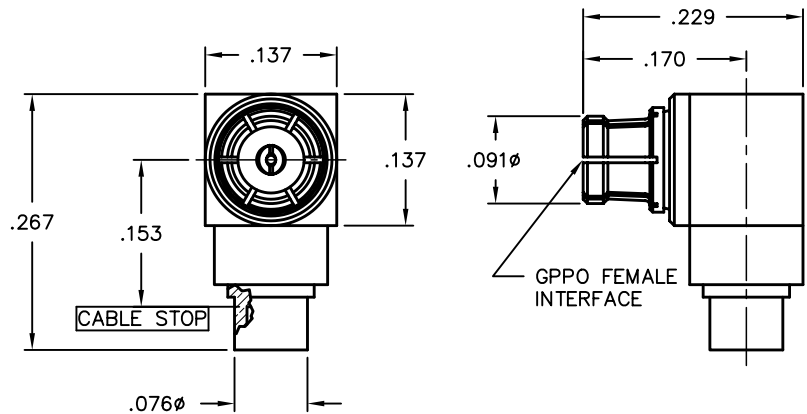

GPPO Cable Connectors

Female High Performance Swept R/A to 0.086 S/R Cable

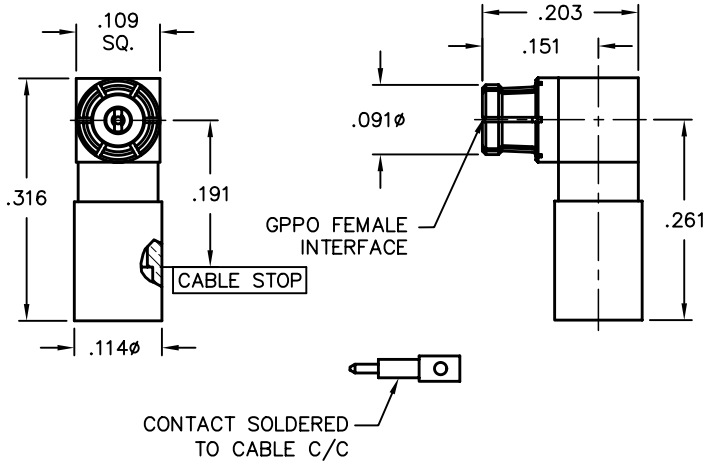

Catalog Number	Tools Recommended
B015-D11-01	B096-A93-01
VSWR (TYP)	A096-A99-10
1.10:1 to 12 GHz	L096-A99-01
1.20:1 to 18 GHz	Assembly Procedure
	AP01-112



Female R/A to 0.086 S/R Cable

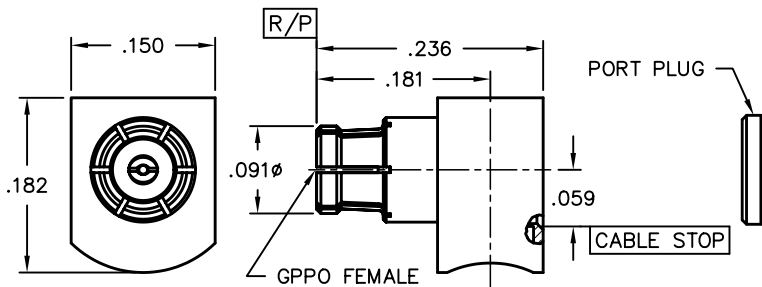

Catalog Number	Tools Recommended
B015-D11-02	B096-A93-01
VSWR (TYP)	A096-A99-10
1.20:1 to 12 GHz	L096-A99-01
1.30:1 to 18 GHz	

Male Snap-in to 0.047 S/R Cable

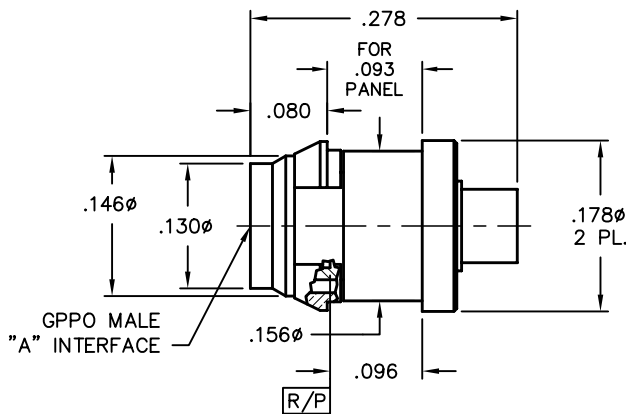

Catalog Number	A	Tools Recommended
B016-B33-01	FD	B096-A99-01
B016-B35-01	SB	L096-A99-02
VSWR (TYP)		Assembly Procedure
1.20:1 to 26.5 GHz		AP01-094
1.30:1 to 40 GHz		



GPPO Cable Connectors

Male Bulkhead Mount to 0.047 S/R Cable

Catalog Number	A	Tools Recommended
B016-B33-02	FD	B096-A99-01
B016-B35-02	SB	L096-A99-02

VSWR (TYP)	Assembly Procedure
1.20:1 to 26.5 GHz	AP01-110
1.30:1 to 40 GHz	

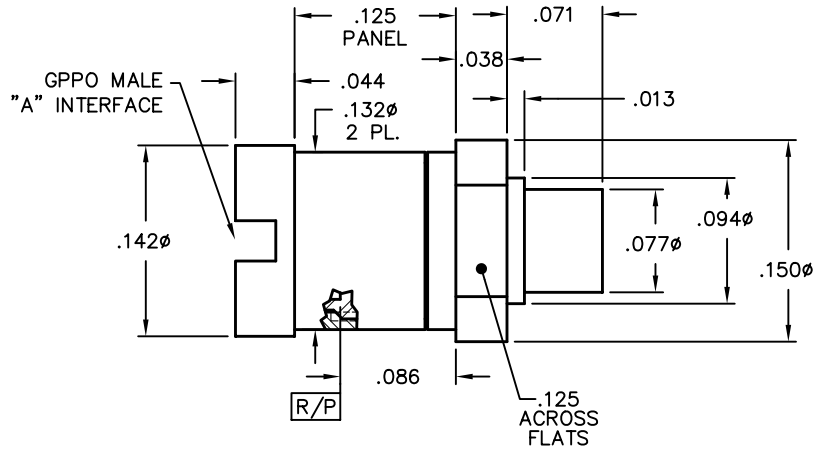

Female Snap-In to 0.047 S/R Cable

Catalog Number	Tools Recommended
0118-961-4	B096-A93-01

VSWR (TYP)	Assembly Procedure
1.10:1 to 12 GHz	A096-A99-09
1.25:1 to 26.5 GHz	L096-A99-02

VSWR (TYP)	Assembly Procedure
1.25:1 to 26.5 GHz	AP01-103

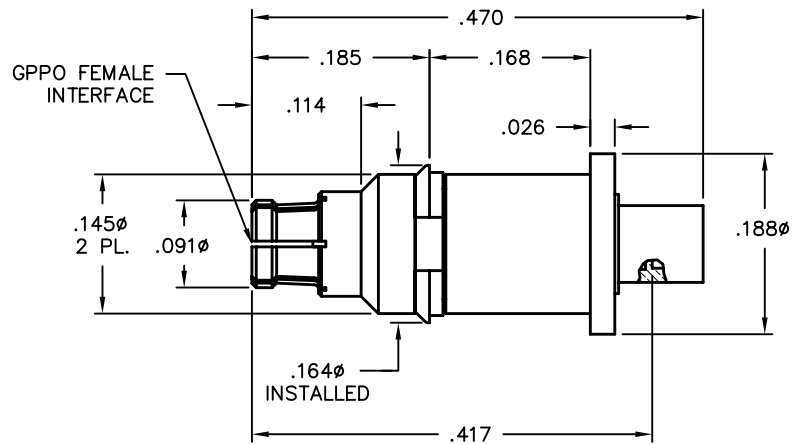

Male Snap-in to 0.086 S/R Cable

Catalog Number	A	Tools Recommended
B016-D33-01	FD	B096-A99-01
B016-D35-01	SB	L096-A99-01

VSWR (TYP)	Assembly Procedure
1.10:1 to 26.5 GHz	AP01-092
1.25:1 to 40 GHz	

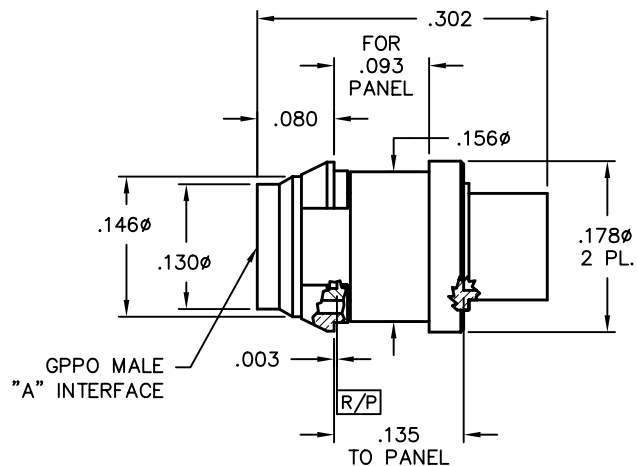

GPPO Cable Connectors

Male Bulkhead Mount to 0.086 S/R Cable

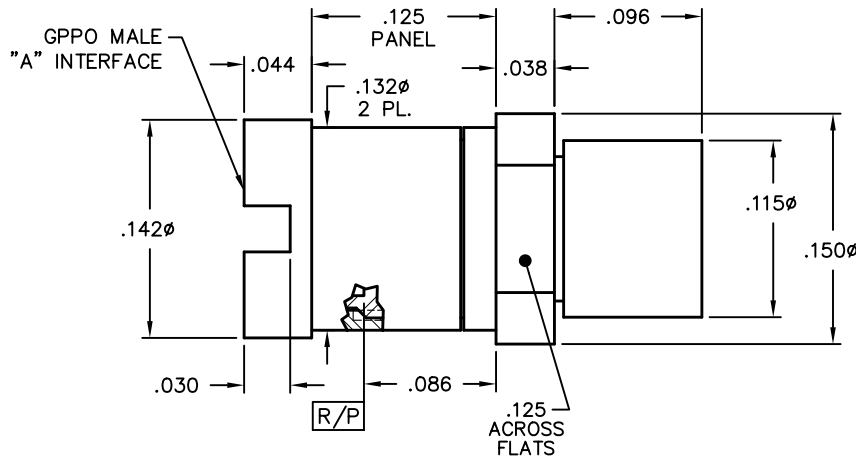

Catalog Number	A	Tools Recommended
B016-D33-02	FD	B096-A99-01
B016-D35-02	SB	L096-A99-01
VSWR (TYP)		Assembly Procedure
1.15:1 to 26.5 GHz		AP01-111
1.30:1 to 40 GHz		

Male Catchers Mitt Snap-in Float Mount to 0.086 S/R Cable

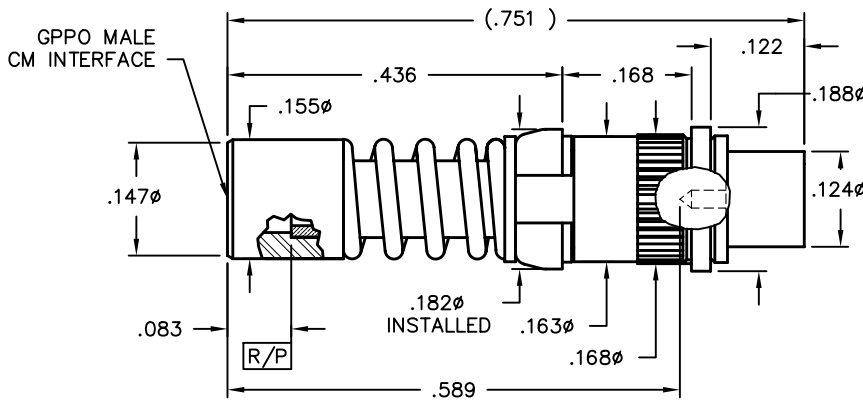

Catalog Number	Tools Recommended
0118-928-4-CM	B096-A99-02
VSWR (TYP)	
1.10:1 to 18 GHz	
1.25:1 to 30 GHz	
Assembly Procedure	
AP01-090	



Male Catchers Mitt R/A Float Mount to 0.086 S/R Cable

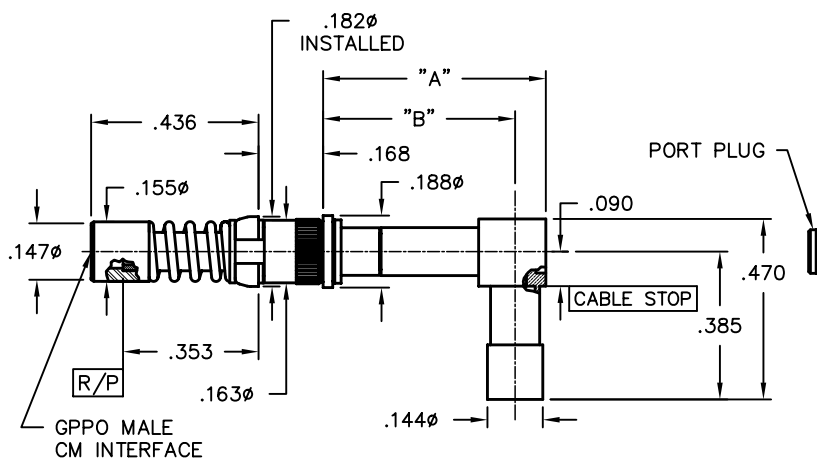

Catalog Number	A	B
B019-K36-01	0.580	0.500
B019-K36-02	0.470	0.390
B019-K36-03	0.705	0.625
Tools Recommended		
B096-A99-02		
Assembly Procedure		
AP01-134		



GPPO Cable Connectors

Female Snap-in to 0.047 S/R Cable

Catalog Number	Tools Recommended
B016-B11-01	B096-A93-01
VSWR (TYP)	A096-A99-09
1.10:1 to 12 GHz	L096-A99-02
1.20:1 to 26.5 GHz	Assembly Procedure
1.30:1 to 40 GHz	AP01-103

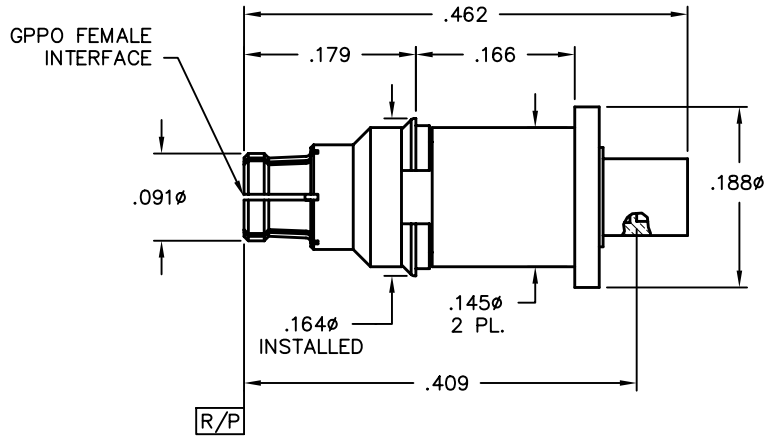

Female Snap-in to 0.086 S/R Cable

Catalog Number	Tools Recommended
0118-958-1	B096-A93-01
VSWR (TYP)	A096-A99-09
1.15:1 to 18 GHz	L096-A99-01
1.50:1 to 40 GHz	Assembly Procedure
	AP01-120

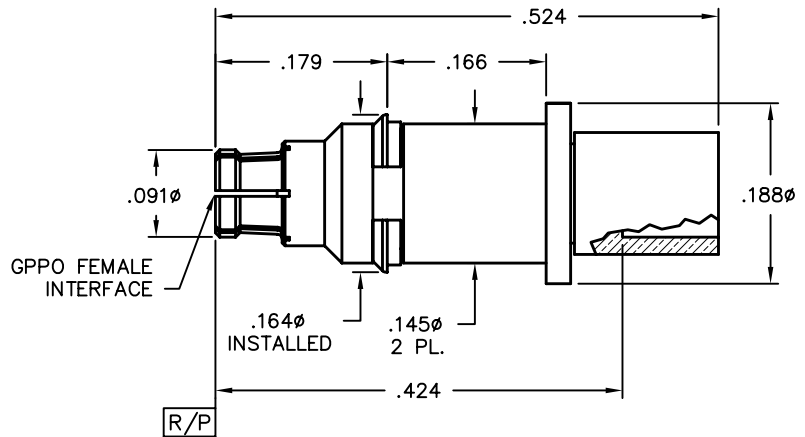

Female Snap-in to 0.086 S/R Cable

Catalog Number	Tools Recommended
0118-958-4	B096-A93-01
VSWR (TYP)	A096-A99-09
1.15:1 to 18 GHz	L096-A99-01
1.50:1 to 40 GHz	Assembly Procedure
	AP01-142

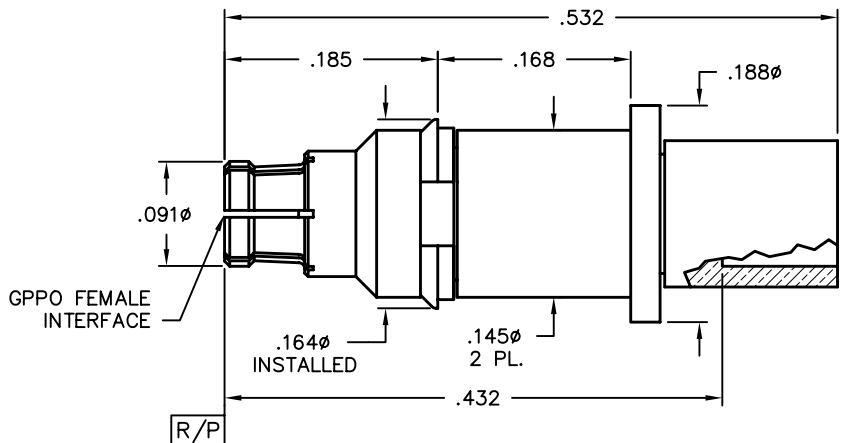

GPPO Cable Connectors

Male 2 Hole Flange Mount to 0.086 S/R Cable

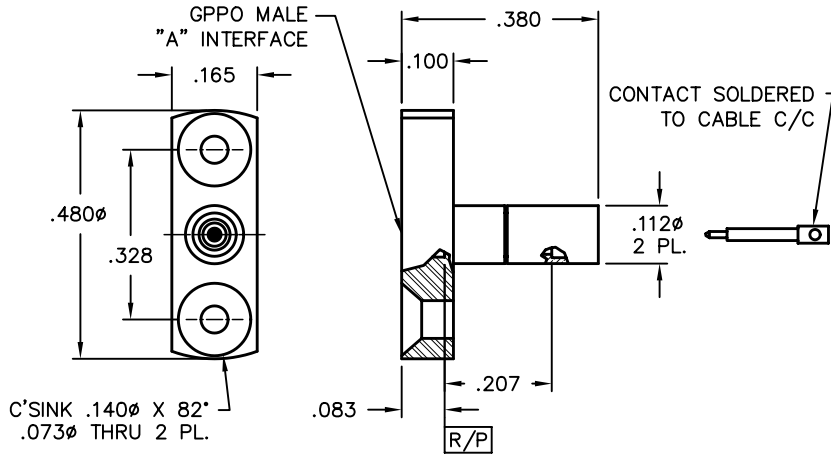

Catalog Number	A
B001-D33-01	FD
B001-D35-01	SB
VSWR (TYP)	
1.30:1 to 40 GHz	
Assembly Procedure	
AP01-119	

Male Flange Mount to 0.116 S/R Cable

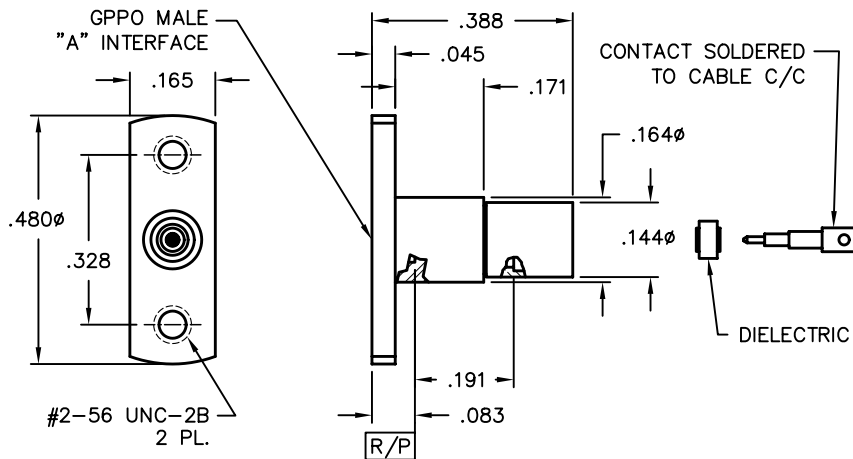

Catalog Number	A
B001-K33-01	FD
B001-K35-01	SB
Tools Recommended	
B096-A99-01	
L096-A99-03	
L096-A99-01	
Assembly Procedure	
AP01-106	

GPPO PCB Mounts

Male PCB 4 Leg Thru Mount Cap C/C

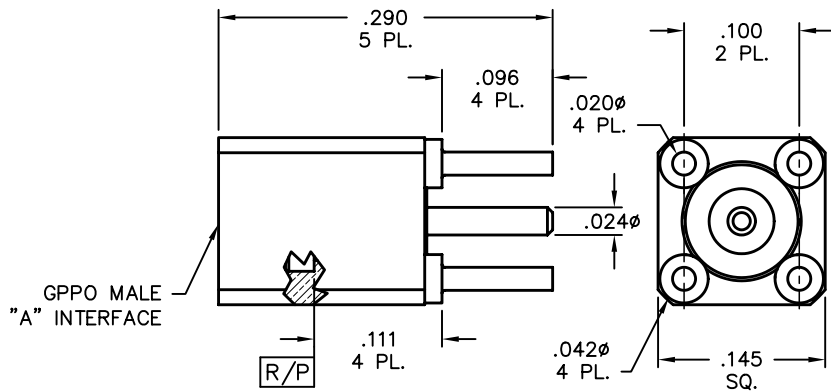

Catalog Number	A
B008-L13-01	FD
B008-L15-01	SB
VSWR (TYP)	
1.35:1 to 26.5 GHz	



GPPO PCB Mounts

Male PCB 4 Leg Thru Mount with Separate C/C

Catalog Number	A
B008-P33-01	FD
B008-P35-01	SB
VSWR (TYP)	
1.20:1 to 20 GHz	

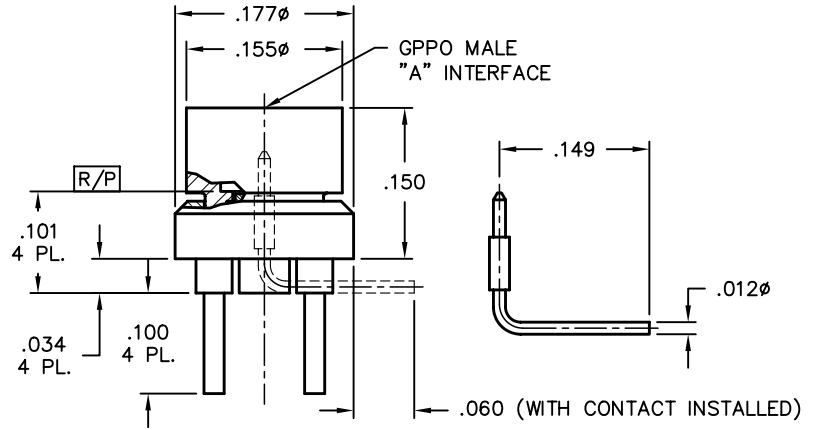

Male Straight to PCB Mount with Separate R/A Pin

Catalog Number	A	L Lengths
0118-959-1-SB-TAB	SB	.055/.100
0118-959-1-FD-TAB	FD	.055/.100

TAB = $L \times 10^3$ inches

VSWR (TYP)	
1.20:1 to 20 GHz	

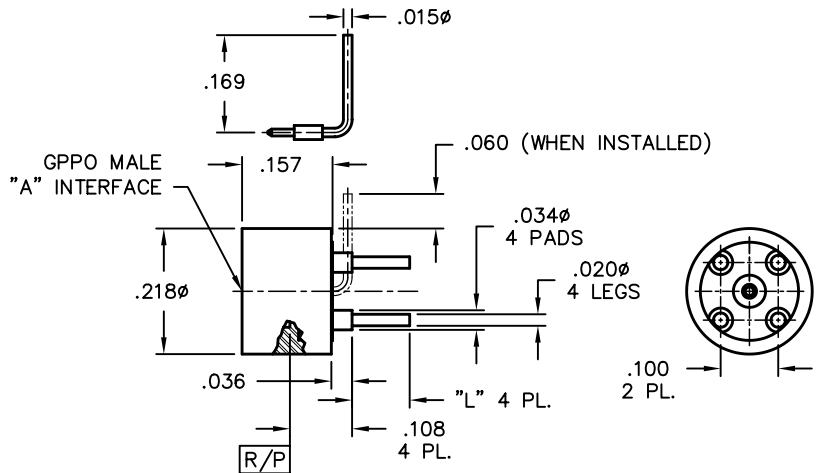

Male Straight to PCB Mount

Catalog Number	A	L Lengths
0118-960-1-FD-TAB	FD	.055/.100
0118-960-1-SB-TAB	SB	.055/.100

TAB = $L \times 10^3$ inches

VSWR (TYP)	
1.20:1 to 26.5 GHz	

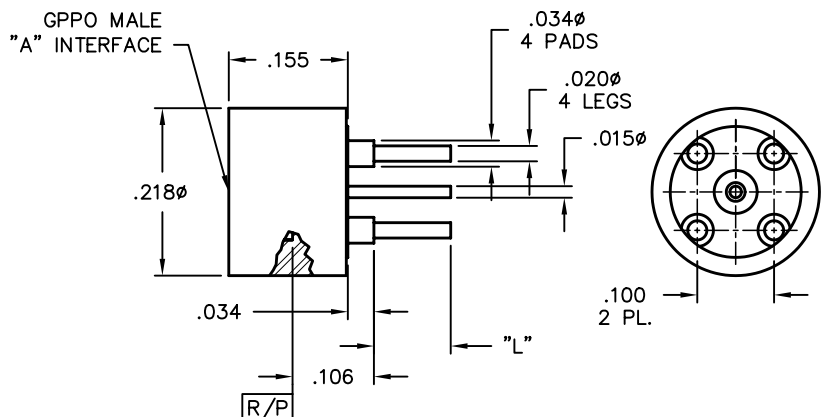

GPPO PCB Mounts

Male R/A PCB 4 Leg Thru Mount Cap C/C

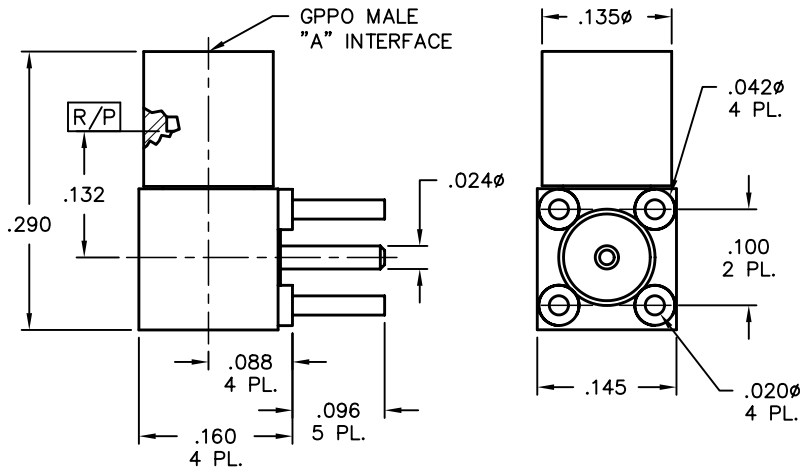

Catalog Number A

B009-P33-01 FD

B009-P35-01 SB

VSWR (TYP)

1.40:1 to 26.5 GHz



**Male R/A PCB Mount
0.135 Legs**

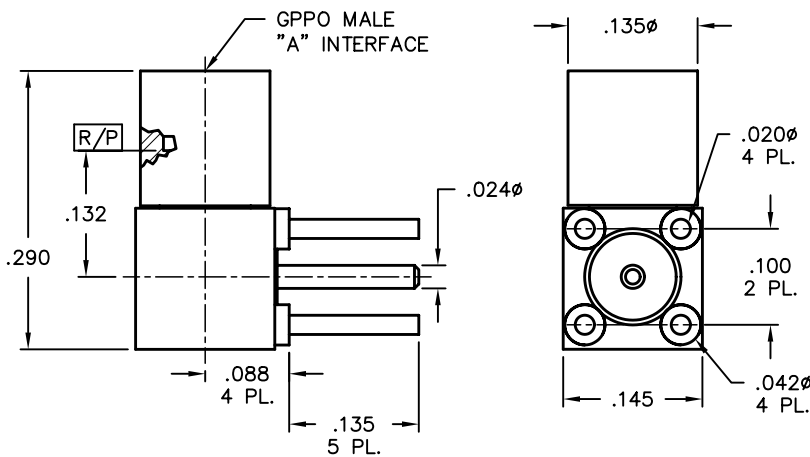

Catalog Number A

B009-P33-02 FD

B009-P35-02 SB

VSWR (TYP)

1.40:1 to 26.5 GHz



GPPO Flange Mounts

Male Flange Mount Shroud

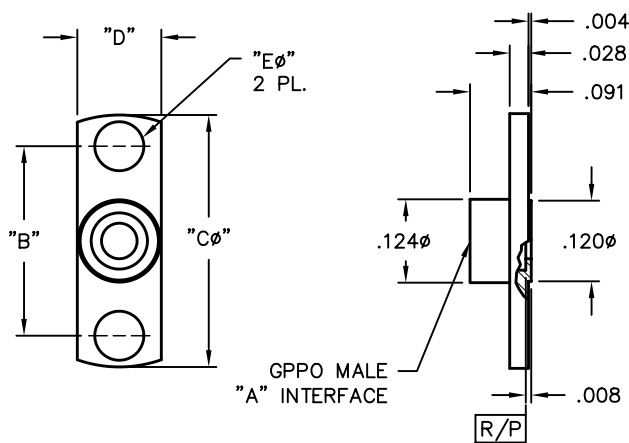

Catalog Number A B C ϕ D E ϕ

B001-A23-01 FD .282 .375 .125 .073

B001-A25-01 SB .282 .375 .125 .073

B001-A23-02 FD .481 .625 .150 .103

B001-A25-02 SB .481 .625 .150 .103

Tools Recommended

B090-A99-08 (for -02 series)

B090-A99-09 (for -01 series)

B090-A99-01



GPPO Flange Mounts

Male Flange Mount Shroud Accepts 0.009 Center Conductor

Catalog Number	A
B001-N33-01	FD
B001-N35-01	SB

VSWR (TYP)

1.25:1 to 26.5 GHz
1.35:1 to 40 GHz

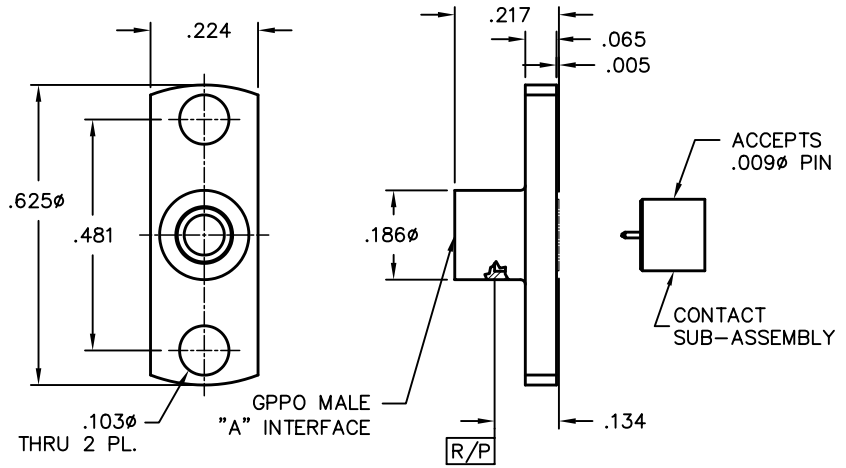

GPPO Edge Mounts

Male PCB Edge Mount

Catalog Number	A
B010-L13-01	FD
B010-L15-01	SB

VSWR (TYP)

1.25:1 to 26.5 GHz

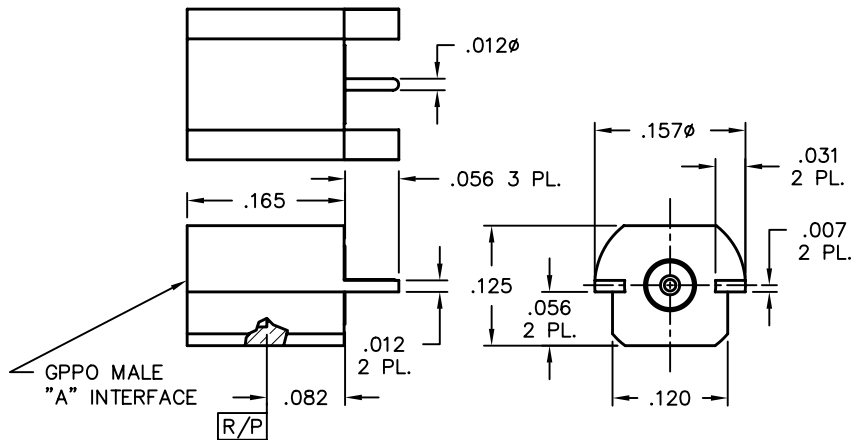

Male PCB Edge Mount High Temperature

Catalog Number	A
B010-L73-01-T	

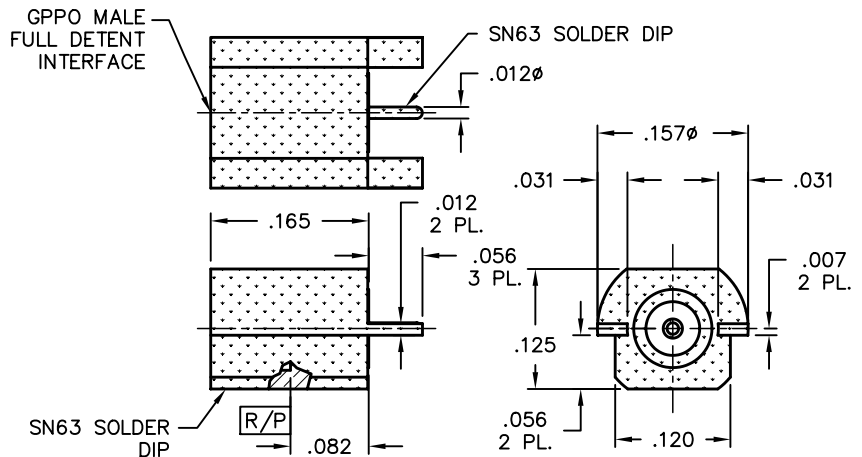

GPPO Edge Mounts

Male Edge Mount with Separate Pin

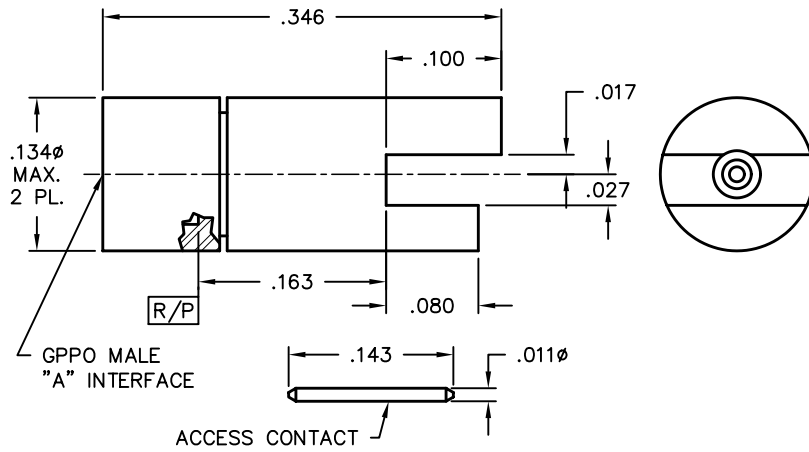

Catalog Number	A
B010-L33-03	FD
B010-L35-03	SB

VSWR (TYP)
1.25:1 to 26.5 GHz



Male Edge Mount with Separate Pin

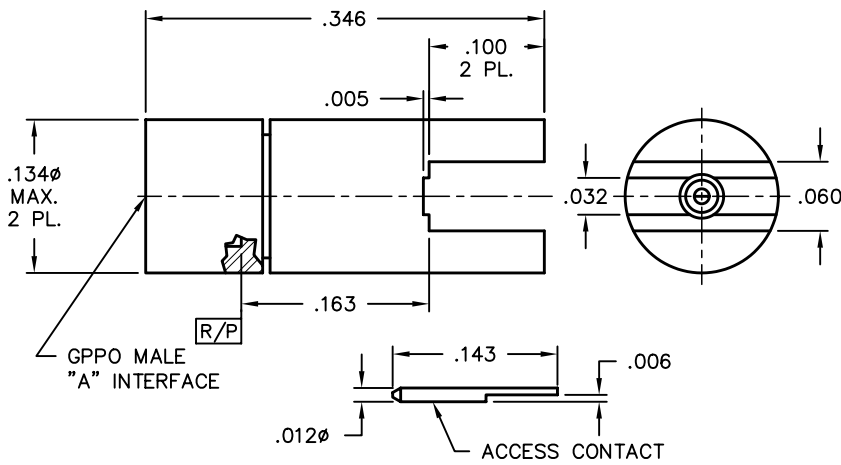

Catalog Number	A
B010-L33-04	FD
B010-L35-04	SB

VSWR (TYP)
1.25:1 to 26.5 GHz



Male PCB Edge Mount

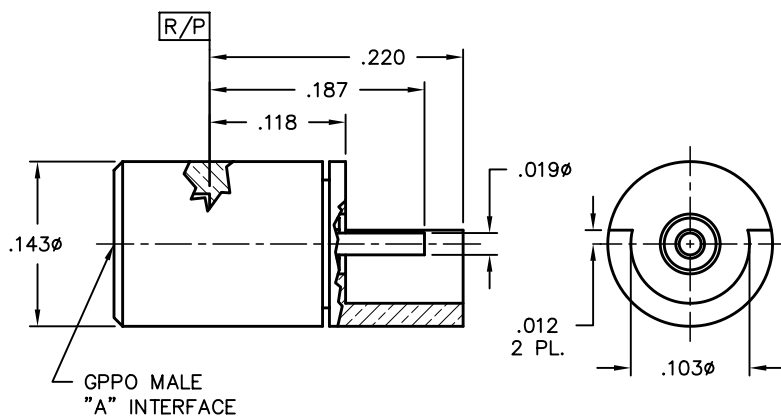

Catalog Number	A
B010-L83-01	FD
B010-L85-01	SB



GPPO Edge Mounts

Male PCB Edge Mount

Catalog Number	A
B010-L83-02	FD
B010-L85-02	SB

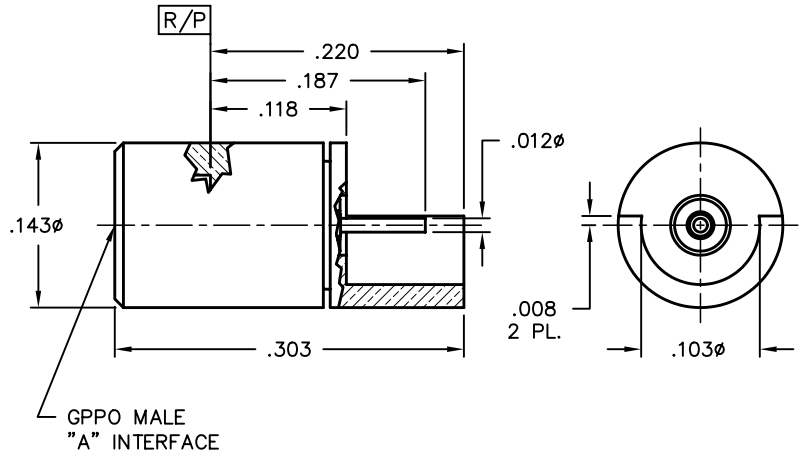

GPPO Surface Mounts

Male PCB Surface Mount with Separate Pin

Catalog Number	A	B	C	D ϕ
B012-L13-01	FD	.140	.093	.012
B012-L15-01	SB	.140	.093	.012
B012-L13-02	FD	.052	.005	.012
B012-L15-02	SB	.052	.005	.012
B012-L13-03	FD	.047	-	-
B012-L15-03	SB	.047	-	-
B012-L13-04	FD	.163	.093	.012
B012-L15-04	SB	.163	.093	.012

VSWR (TYP)
1.30:1 to 20 GHz

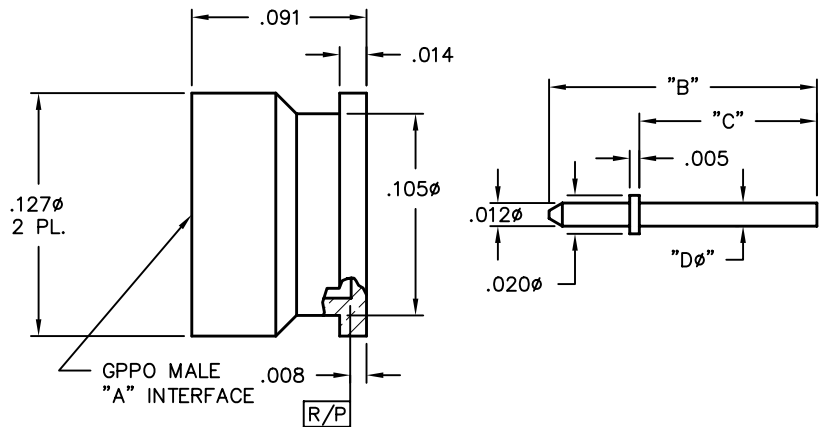

Male PCB Surface Mount

Catalog Number	A
B012-P93-01	FD
B012-P95-01	SB

VSWR (TYP)
1.20:1 to 20 GHz

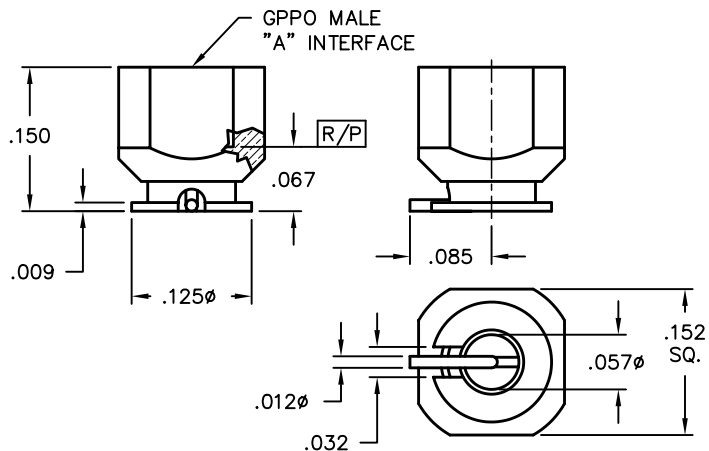

GPPO Surface Mounts

Male Coplanar Surface Mount

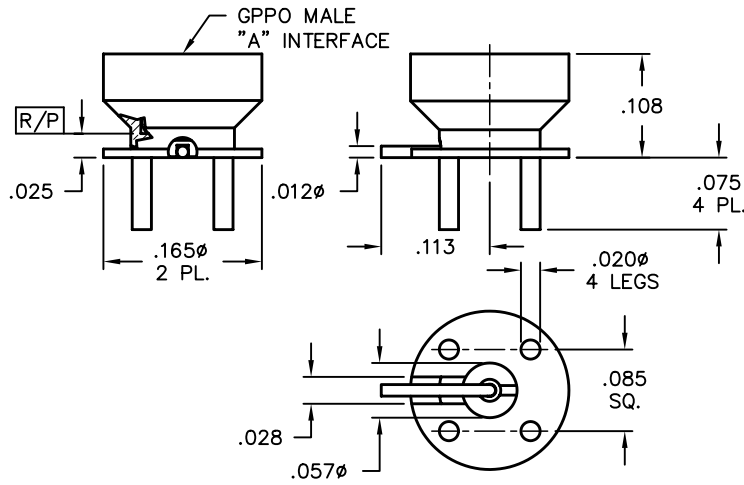

Catalog Number	A
B012-P93-02	FD
B012-P95-02	SB
VSWR (TYP)	
1.20:1 to 20 GHz	



Male R/A Surface Mount

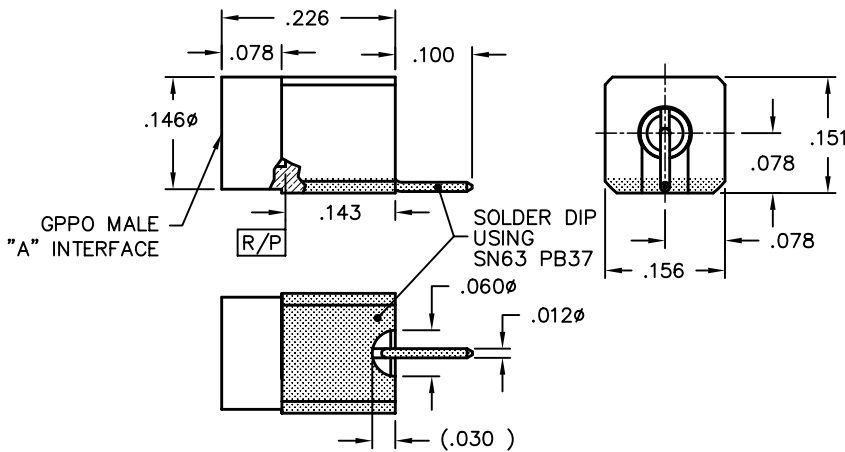

Catalog Number	A
B013-L93-01	FD
B013-L95-01	LD
VSWR (TYP)	
1.20:1 to 20 GHz	

GPPO Thread-In Shrouds

Male Thread-in Shroud

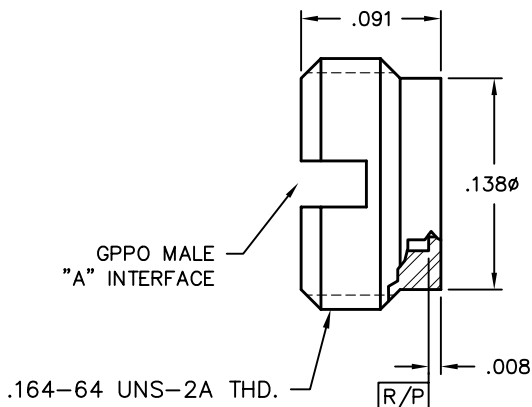

Catalog Number	A
B003-A23-01	FD
B003-A25-01	SB
Tools Recommended	
B090-A99-05	
B097-A99-01 for FD	
B097-A99-02 for SB	
Assembly Procedure	
AP01-101	



GPPO Thread-In Shrouds

Male Thread-in

Catalog Number	A	B
B003-L33-01	FD	.015
B003-L35-01	SB	.015
B003-L33-02	FD	.067
B003-L35-02	SB	.065

VSWR (TYP)

1.25:1 to 26.5 GHz
 1.35:1 to 40 GHz

Tools Recommended

B097-A99-01 for FD
 B097-A99-02 for SB

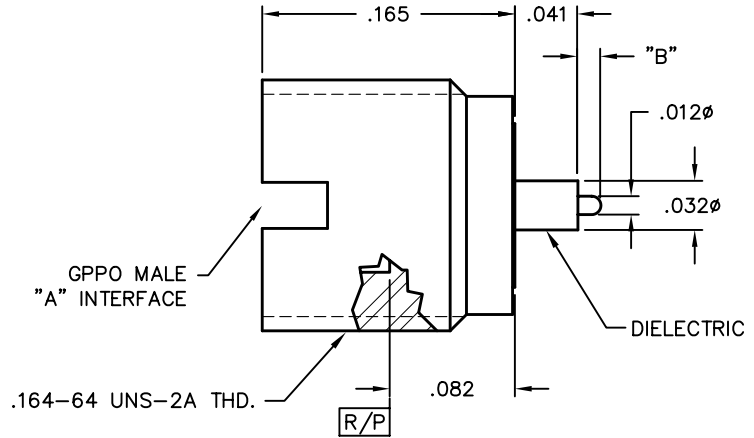

Male Thread-in

Catalog Number	A
B003-L33-03	FD
B003-L35-03	SB

VSWR (TYP)

1.35:1 to 26.5 GHz
 1.40:1 to 40 GHz

Tools Recommended

B097-A99-01 for FD
 B097-A99-02 for SB

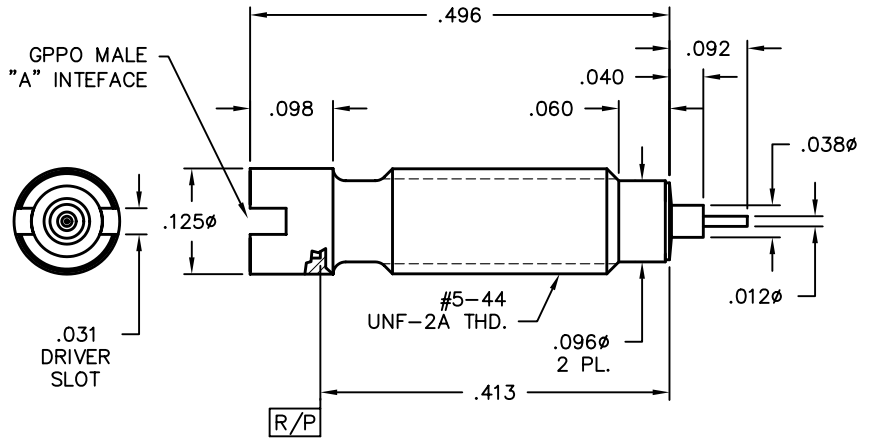

Male Thread-in

Catalog Number	A
B003-L33-05	FD
B003-L35-05	SB

VSWR (TYP)

1.25:1 to 26.5 GHz
 1.35:1 to 40 GHz

Tools Recommended

B097-A99-01 for FD
 B097-A99-02 for SB

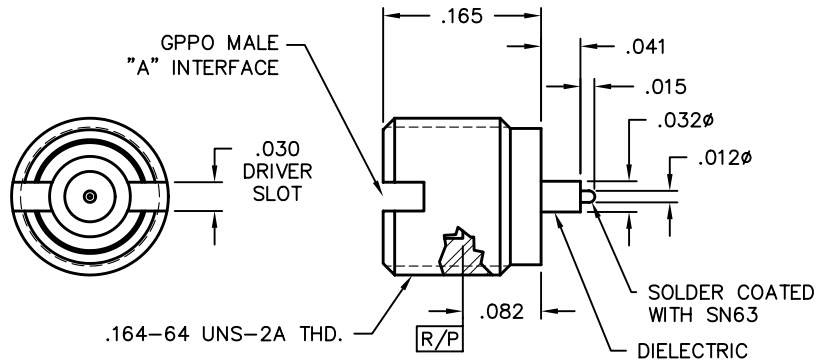

GPPO Thread-In Shrouds

**Male Thread-in Shroud
Accepts .012 ϕ C/C**

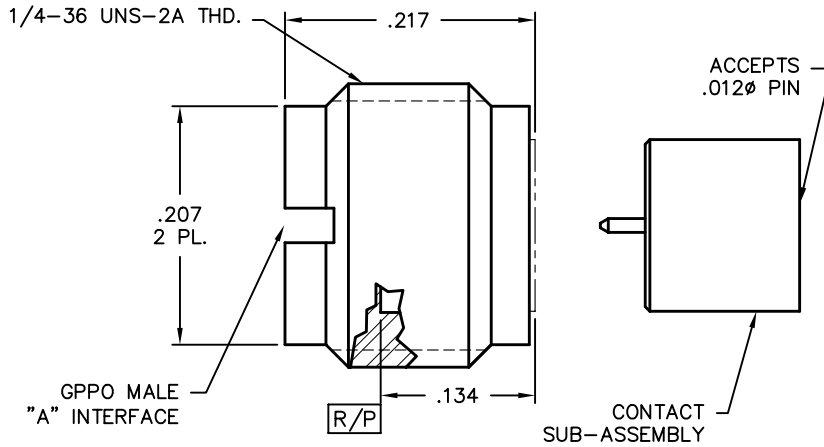

Catalog Number	A	Tools Recommended
B003-N33-01	FD	A090-A99-07
B003-N35-01	SB	B097-A99-01 for FD B097-A99-02 for SB
VSWR (TYP)		
1.25:1 to 26.5 GHz		Assembly Procedure AP01-104
1.35:1 to 40 GHz		



**Male Thread-in Shroud
Accepts .009 ϕ C/C**

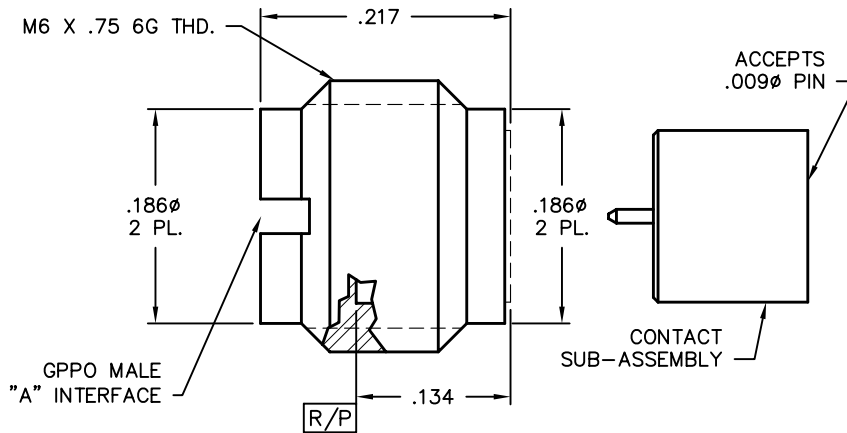

Catalog Number	A	Tools Recommended
B003-N33-02	FD	B097-A99-01 for FD
B003-N35-02	SB	B097-A99-02 for SB
VSWR (TYP)		
1.25:1 to 26.5 GHz		
1.35:1 to 40 GHz		



**Male Thread-in to Stripline Launch
with 0.015 Pin**

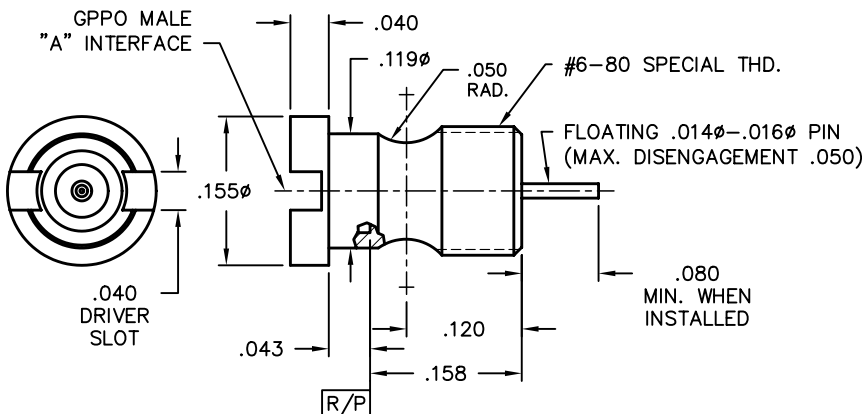

Catalog Number	A	Tools Recommended
B024-L33-01	FD	B097-A99-01 for FD
B024-L35-01	SB	B097-A99-02 for SB
VSWR (TYP)		
1.25:1 to 26.5 GHz		
1.35:1 to 40 GHz		

GPPO Thread-In Shrouds

Male Thread-in

Catalog Number	A	Tools Recommended
B024-L33-02	FD	B097-A99-01 for FD
B024-L35-02	SB	B097-A99-02 for SB

VSWR (TYP)

1.35:1 to 26.5 GHz
 1.40:1 to 40 GHz

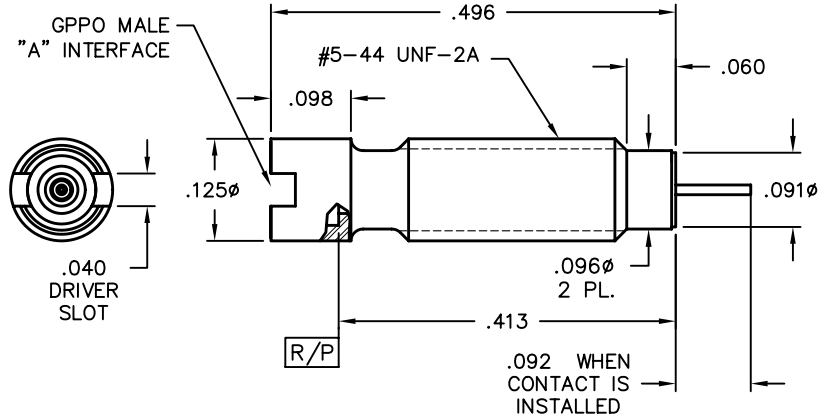

GPPO Hermetic Shrouds

Male Hermetic Shroud Full Size

Catalog Number	A	L Lengths
B007-M43-01-TAB-X	FD	.030/.050/.070/.090
B007-M45-01-TAB-X	SB	.030/.050/.070/.090

VSWR (TYP)

1.25:1 to 26.5 GHz
 1.35:1 to 40 GHz

TAB = L x 10³ inches

X = Customer defined. Straight (S) or Radius (R) cut.

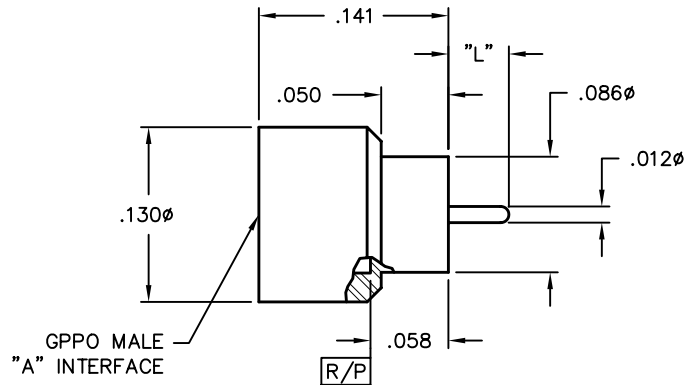

Male Hermetic Shroud Full Size

Catalog Number	A	L Lengths
B007-M46-01-TAB-X	SB	.030/.050/.070/.090

VSWR (TYP)

1.25:1 to 26.5 GHz
 1.35:1 to 40 GHz

TAB = L x 10³ inches

X = Customer defined. Straight (S) or Radius (R) cut.

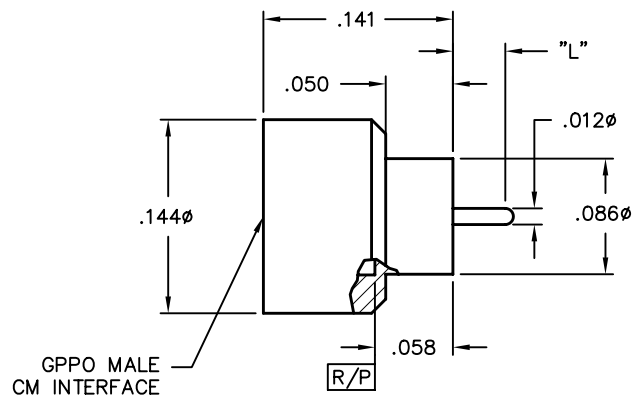

GPPO Loads

Female 50 Ohm Load

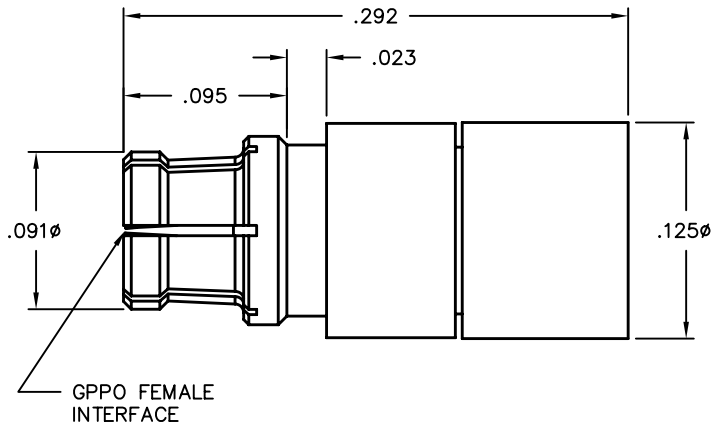

Catalog Number	Grade
B055-A11-01	TEST GRADE
B055-A11-02	FIELD GRADE

VSWR (TYP)

TEST GRADE : 1.15 + .011 x F(GHz):1 to 40 GHz
 FIELD GRADE : 1.15 + .013 x F(GHz):1 to 40 GHz



Female 50 Ohm R/A Load

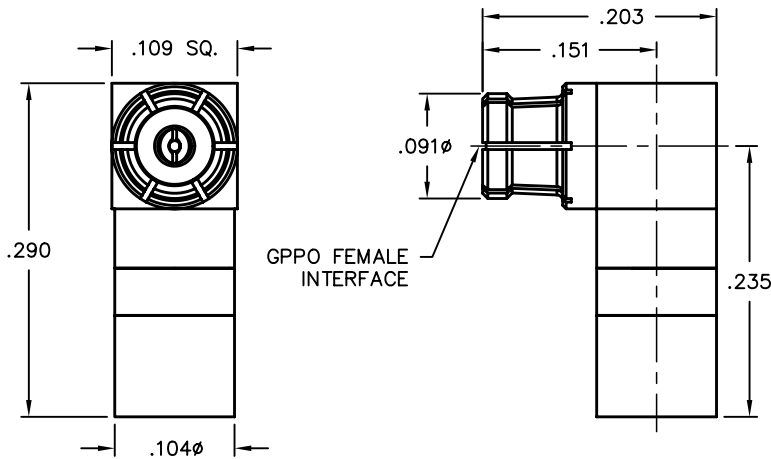

Catalog Number	Grade
B055-A11-05	TEST GRADE

VSWR (TYP)

1.30:1 to 12 GHz



Male 50 Ohm Load

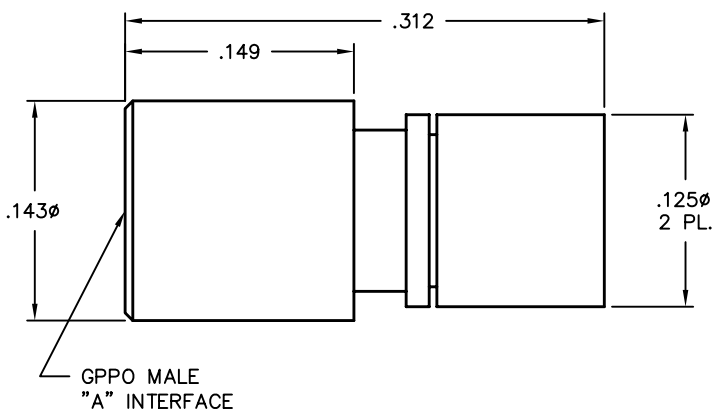

Catalog Number	A	B
B055-A13-01	FD	TEST GRADE
B055-A15-01	SB	TEST GRADE
B055-A13-02	FD	FIELD GRADE
B055-A15-02	SB	FIELD GRADE

VSWR (TYP)

TEST GRADE : 1.20:1 to 18 GHz, 1.30:1 to 40 GHz
 FIELD GRADE : 1.20:1 to 18 GHz, 1.50:1 to 40 GHz



GPPO Loads

Female 1/2 Watt 50 Ohm Load

Catalog Number

B055-A11-06

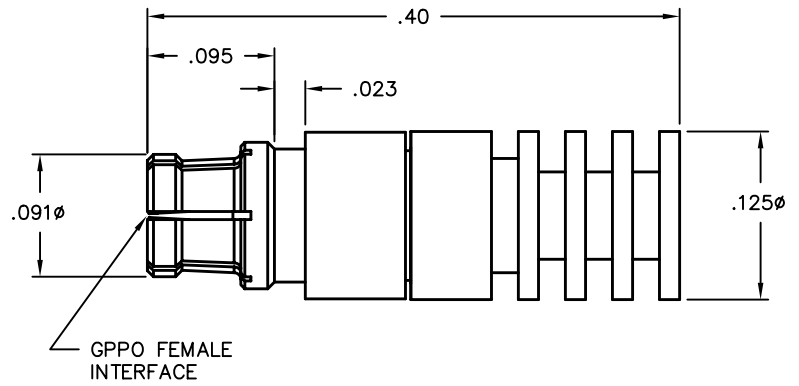

GPPO Hermetic Seals

50 Ohm Hermetic Seal

Catalog Number

	A	B
Y007-L42-01	0.125	0.047
Y007-L42-05	0.091	0.039

	A	B
Y007-L42-01	0.125	0.047
Y007-L42-05	0.091	0.039

VSWR (TYP)

1.25:1 to 26.5 GHz

1.35:1 to 40 GHz

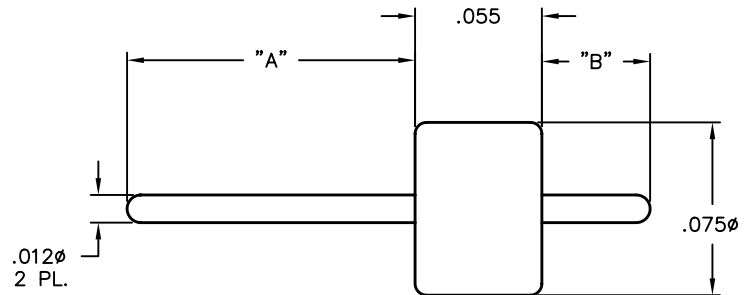

GPPO Pins

GPPO Pin

Catalog Number

Y071-L02-01

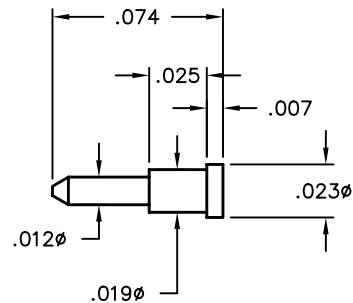

GPPO Pins

GPPO Pin

Catalog Number

Y071-L92-01

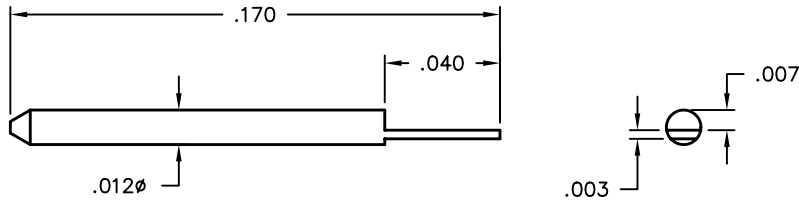

GPPO Multiposition Blocks

Male 2-Position Smooth Bore Mounting Block

Catalog Number

B007-L45-15

Mating Block:

B007-L45-15-T

B007-L45-04-TAB

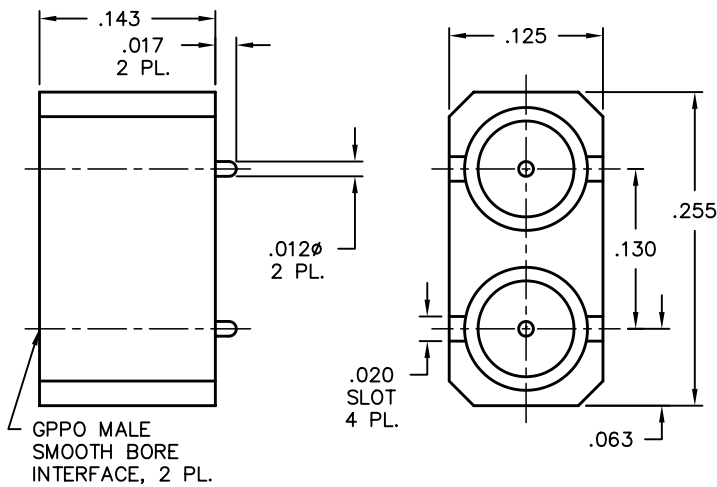

GPPO Multiposition Blocks

Male 2-Position Smooth Bore Mounting Block, Pre-Tinned

Catalog Number

B007-L45-15-T

Mating Block:

B007-L45-15

B007-L45-04-TAB

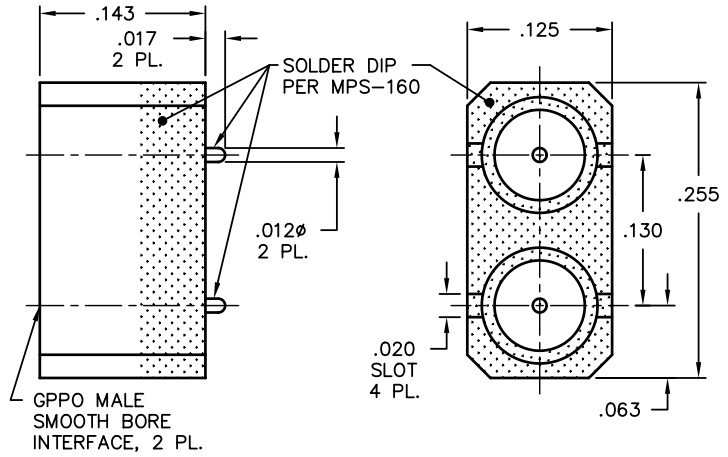

Male 2-Position Smooth Bore Mounting Block

Catalog Number

B007-L45-04-TAB

Mating Block:

B007-L45-15

B007-L45-15-T

TAB = $L \times 10^3$ inches

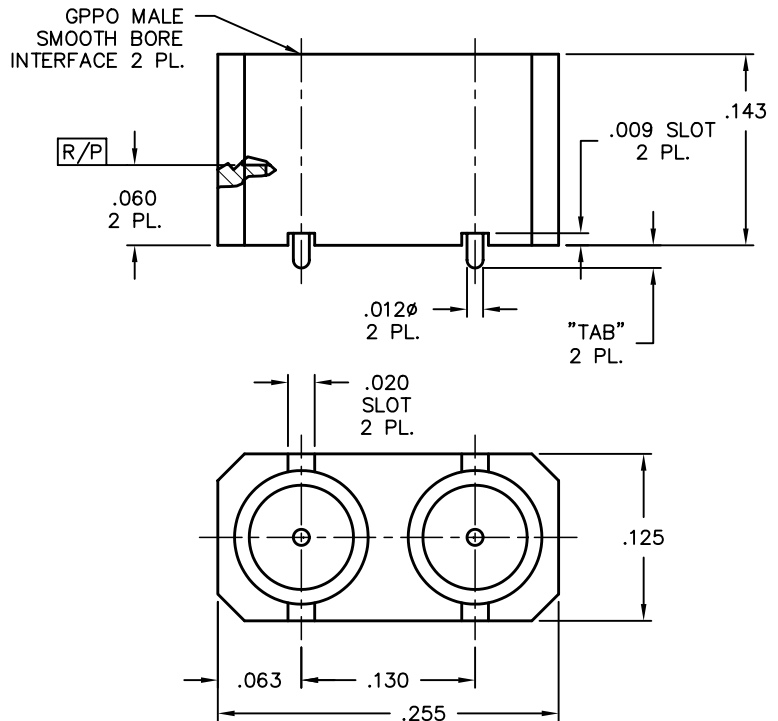

GPPO Multiposition Blocks

Male 4-Position Full Detent R/A to 0.047 Flex Cable

Catalog Number

B031-B93-01-4

Mating Block:

B031-B95-01-4

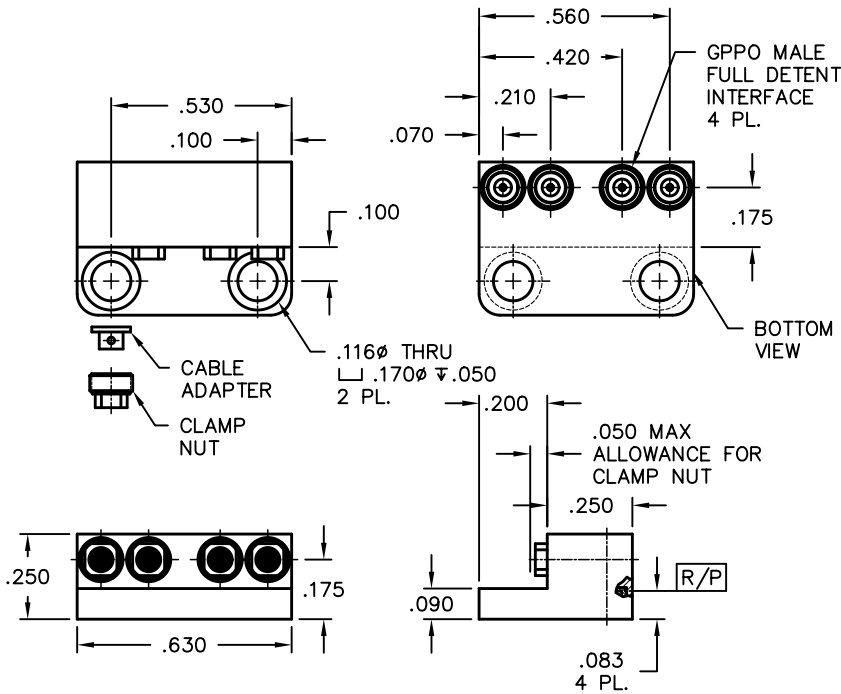

Male 6-Position Full Detent R/A to 0.047 Flex Cable

Catalog Number

B031-B93-01-6

Mating Block:

B031-B95-01-6

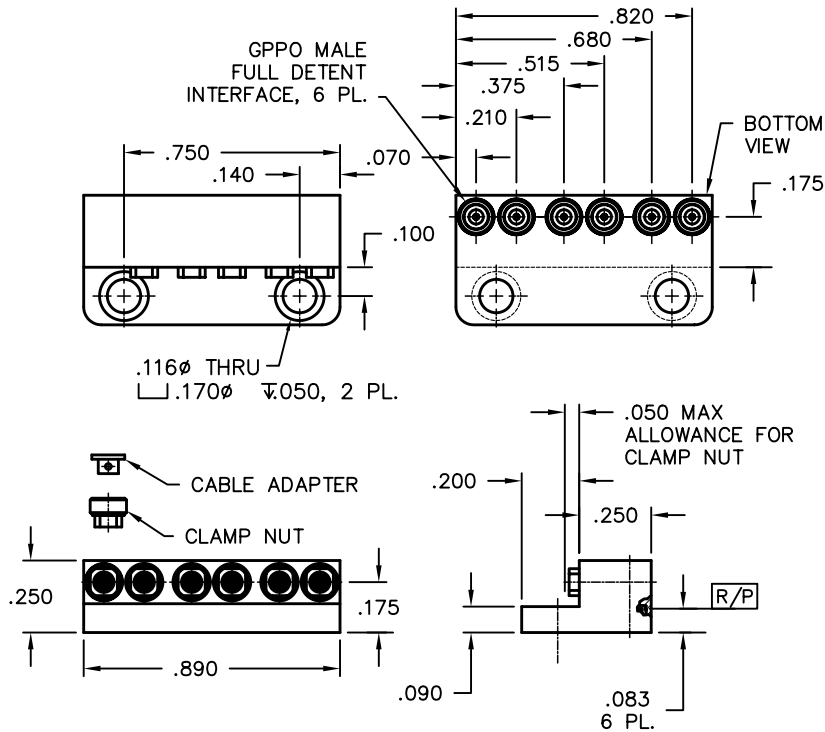

GPPO Multiposition Blocks

Male 4-Position Full Detent R/A to 0.047 Flex Cable

Catalog Number

B031-B93-02-4

Mating Block:

B031-B95-02-4

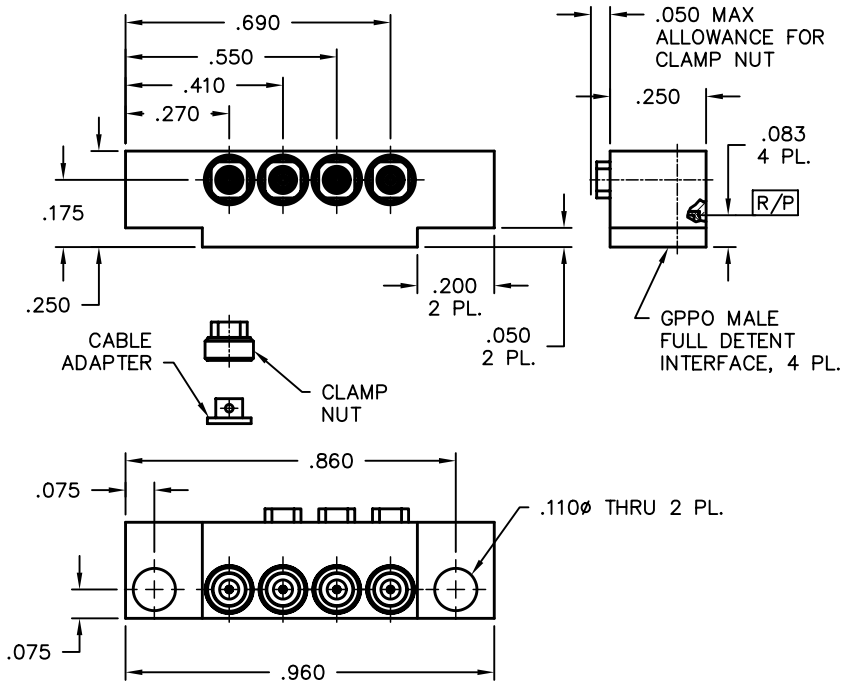

Male 4-Position Full Detent R/A to 0.047 Flex Cable

Catalog Number

B031-B93-03-4

Mating Block:

B031-B95-03-4

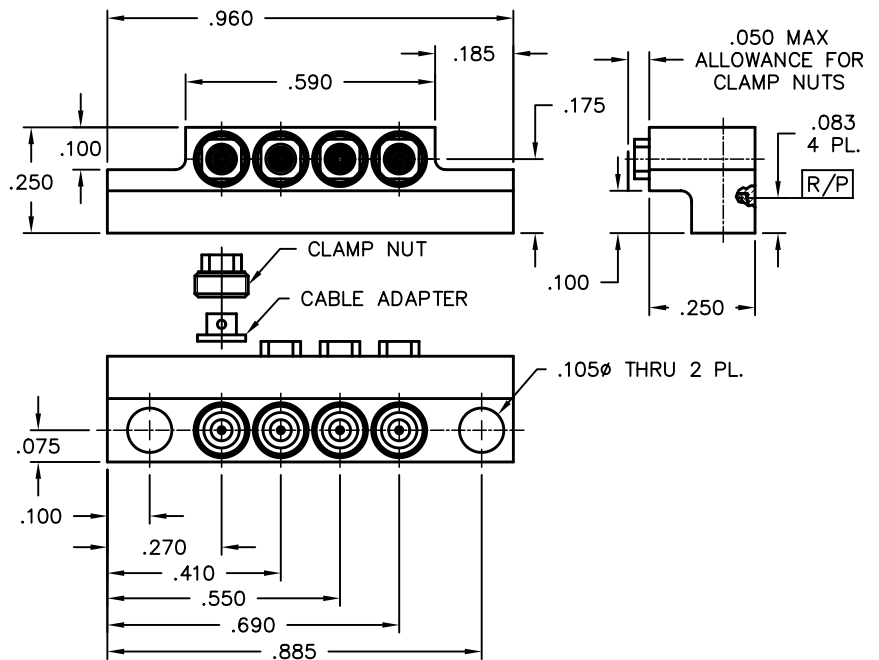

GPPO Multiposition Blocks

GPPO Male Full Detent Dual Block R/A to .086 Hand Formable Cable

Catalog Number

B011-A93-01

Mating Block:

B010-A95-13

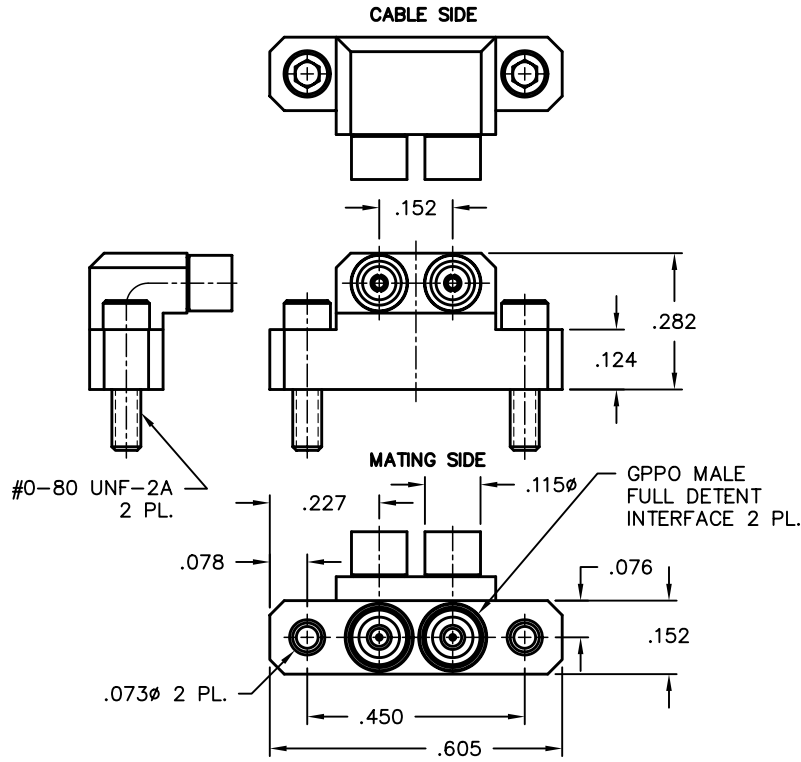

GPPO Smooth Bore Dual Shroud Block

Catalog Number

B010-A95-13

Mating Block:

B011-A93-01

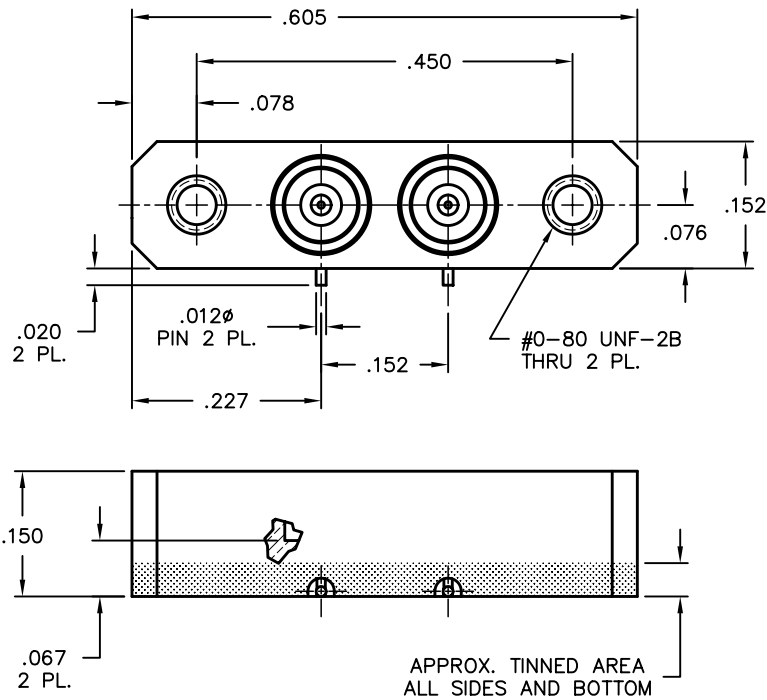

GPPO Multiposition Blocks

**3-Position Straight GPPO
Male Full Detent PWB Block Assembly**

Catalog Number

B008-L13-05

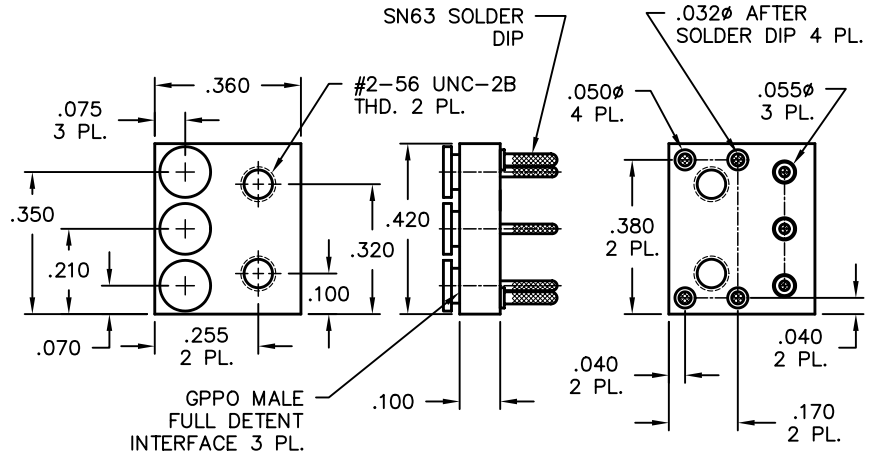

**7-Position GPPO Male R/A PWB
Block Assembly**

Catalog Number

B030-L93-02-7

B030-L95-02-7

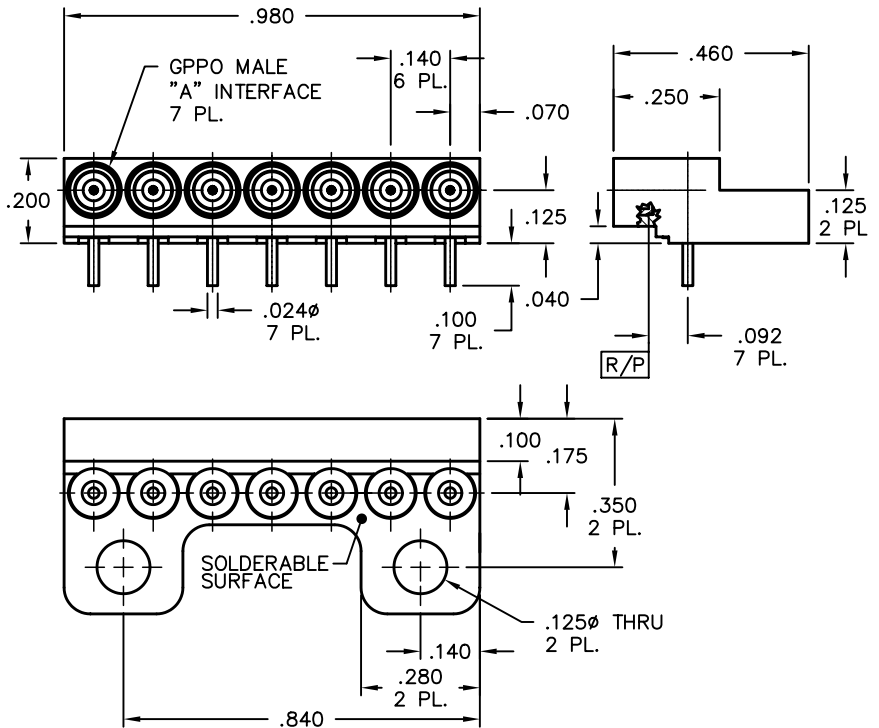

GPPO Multiposition Blocks

Male Smooth Bore 6-Position Mounting Block

Catalog Number

B010-A95-07

Mating Block:
B010-A93-07

Uses pin: Y071-L02-01

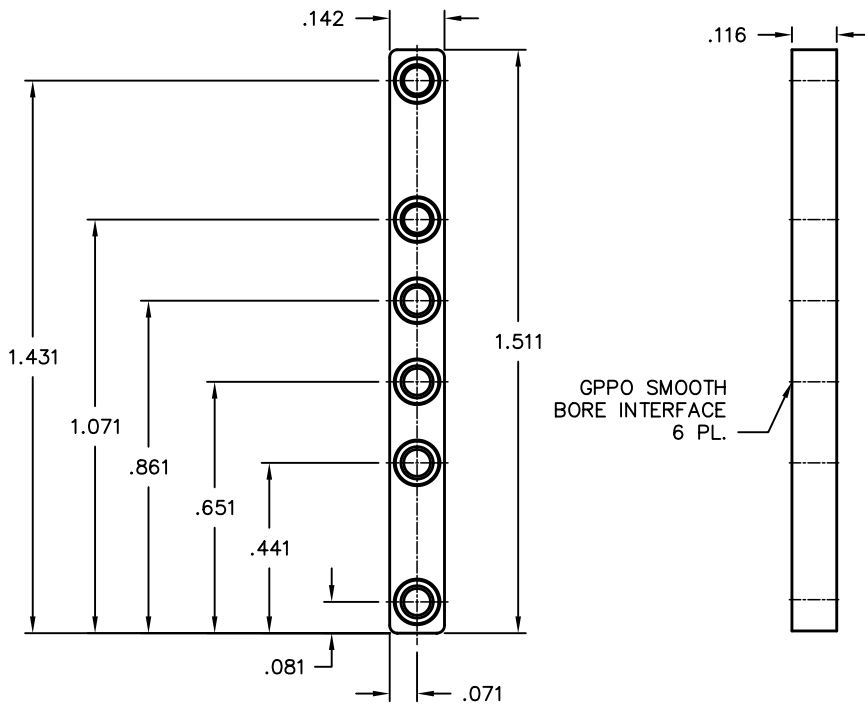

NOTES

G3PO Products

- Center-to-center spacing of 0.085" and board-to-board spacing of 0.120" are available for increased package density
- Frequency from DC to 100 GHz
- Designed to accommodate both radial and axial misalignment with negligible VSWR change
- Adapters available to 1.85mm and SMA



G3PO™ Specifications

General Characteristics

Impedance	50 ohms nominal
Frequency range	DC to 100 GHz
Temperature range	-55°C thru 165°C

Electrical Characteristics

VSWR	1.10:1 to 26.5 GHz typical; 1.25 : 1 typical to 65 GHz
Insertion loss	.03 √f (GHz)
DWV@ Sea Level:	250 Vrms
Insulation resistance	3,500 megohms min.
Contact resistance	
Outer conductor	2 milliohms max.
Inner conductor	6.0 milliohms max.
RF leakage	-80 dB (typical mated pair)

Mechanical Characteristics

Mate/Demate Cycles	Full Detent - 100min.; Smooth Bore - 500min.
Force to engage/disengage	Full Detent - 2.5lbs.typ./4.5lbs.typ.; SB - 1.2lbs.typ./1.0lbs.typ.
Tolerated misalignment	
Radial	+/- 0.010
Axial	0.010 (flush to 0.010 from the reference plane)

Environmental Characteristics

Thermal Shock	MIL-STD-202, Method 107, Condition B
Salt Spray	MIL-STD-202, Method 101
Vibration	MIL-STD-202, Method 204
Shock	MIL-STD-202, Method 213, Condition I
Moisture resistance	MIL-STD-202, Method 106, except Step 7B

Materials (typical)

Bodies	Beryllium Copper per ASTM B196 and or/ASTM B197
Outer contacts	Beryllium Copper per ASTM B196 and or/ASTM B197
Center contacts	Beryllium Copper per ASTM B196 and or/ASTM B197
Insulators	PTFE Fluorocarbon per ASTM D1710
Insulators	Polyamide-imide per ASTM D5204

Finish (typical)

Bodies	Gold plated per MIL-G-45204, Type I, Grade C, Class 1, Over Nickel Plate per SAE AMS-QQ-N-290
Contacts	Gold plated per MIL-G-45204, Type I, Grade C, Class 1, Over Nickel Plate per SAE AMS-QQ-N-290

G3PO Blindmate Interconnects

Female Blindmate Interconnect

Catalog Number

R1R1-0001-01

VSWR (TYP)

1.15:1 to 40 GHz

1.25:1 to 65 GHz

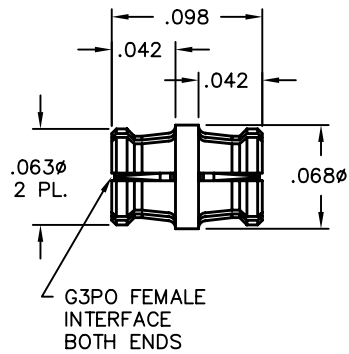

Female Blindmate Interconnect

Catalog Number

R1R1-0001-04

VSWR (TYP)

1.15:1 to 40 GHz

1.25:1 to 65 GHz

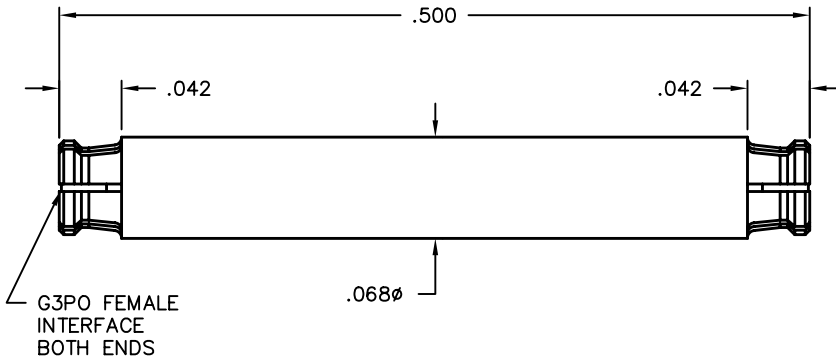

Female Blindmate Interconnect

Catalog Number

R1R1-0001-03-118

Grooves

1

A

0.118

R1R1-0001-03-134

2

0.134

R1R1-0001-03-188

3

0.188

VSWR (TYP)

1.15:1 to 40 GHz

1.25:1 to 65 GHz

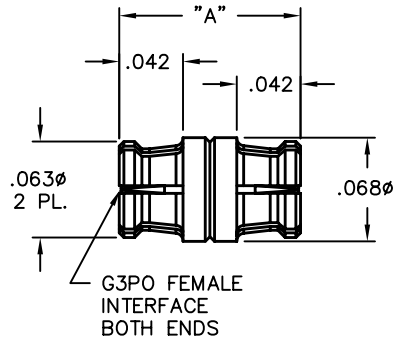

G3PO Cable Connectors

Female Straight to 0.047 S/R Cable

Catalog Number

R014-B11-01

VSWR (TYP)

1.20:1 to 40 GHz

1.30:1 to 65 GHz

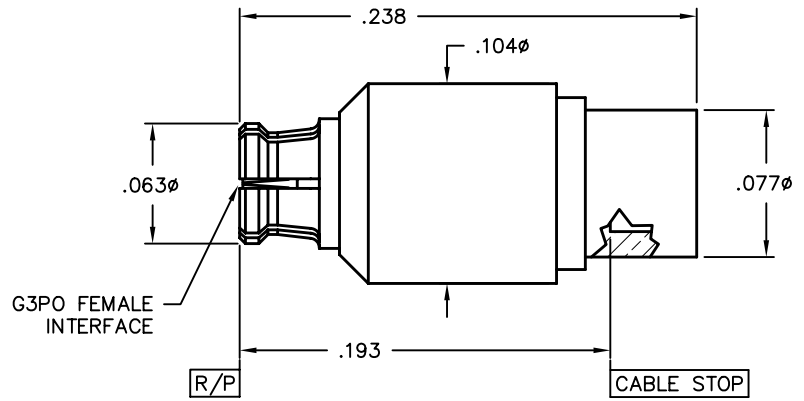

Male Straight to 0.047 S/R Cable

Catalog Number A

R014-B13-01 FD

R014-B15-01 SB

VSWR (TYP)

1.20:1 to 40 GHz

1.30:1 to 65 GHz

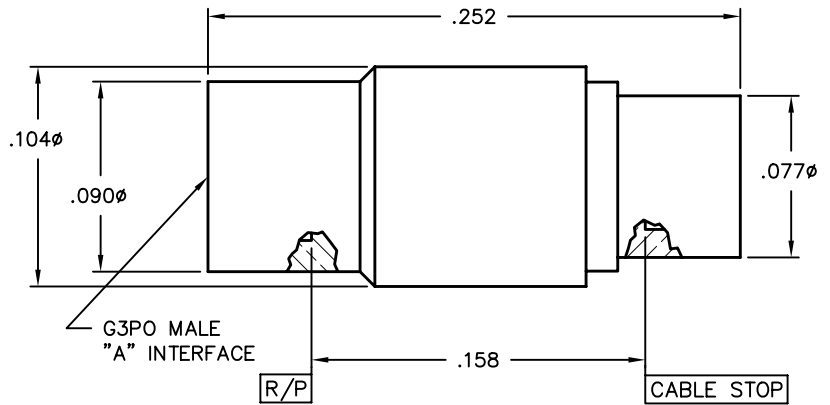

Female R/A to 0.047 S/R Cable

Catalog Number

R015-B11-02

VSWR (TYP)

1.15:1 to 30 GHz

1.25:1 to 50 GHz

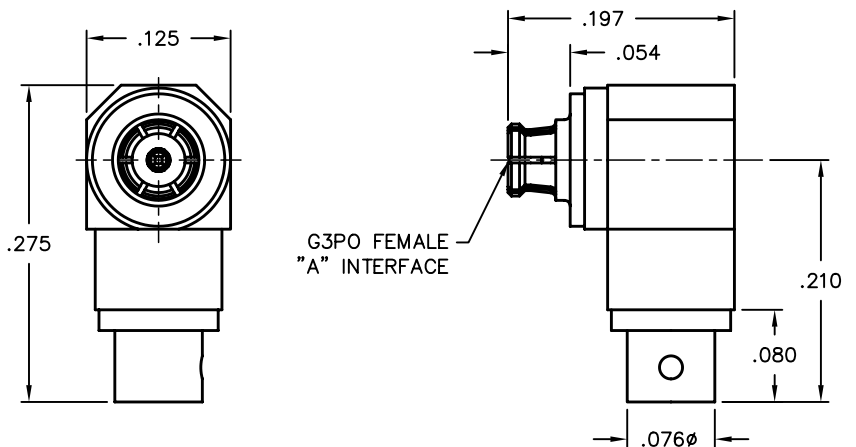

G3PO PCB Mounts

Male Full Detent PCB Thru Mount

Catalog Number

R008-L13-02

VSWR (TYP)

1.15:1 to 40 GHz

1.25:1 to 65 GHz

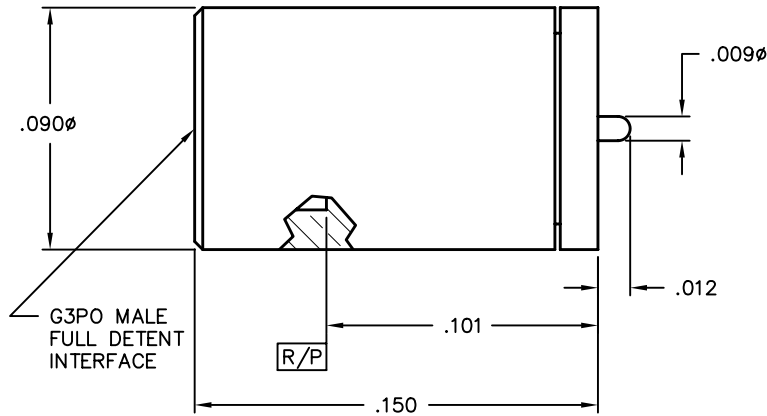

Male Catchers Mitt PCB Shroud with Nailhead Pin

Catalog Number

R008-L16-01

VSWR (TYP)

1.20:1 to 40 GHz

1.30:1 to 65 GHz

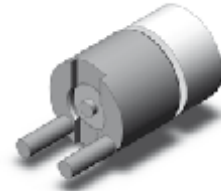
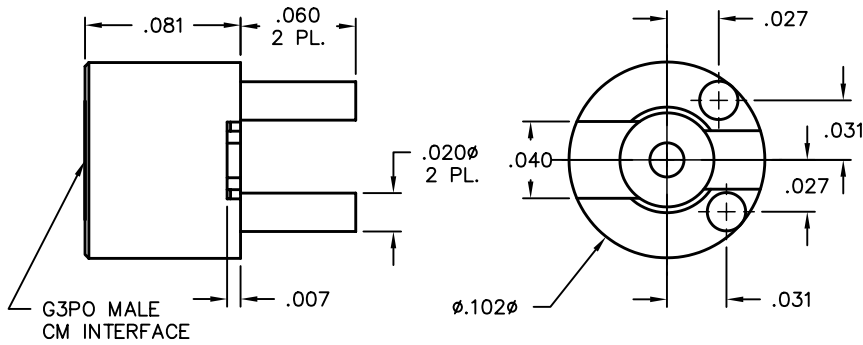

G3PO Edge Mounts

PCB Edge Mount

Catalog Number **A**

R010-L13-03 FD

R010-L15-03 SB

VSWR (TYP)

1.20:1 to 40 GHz

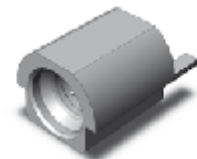
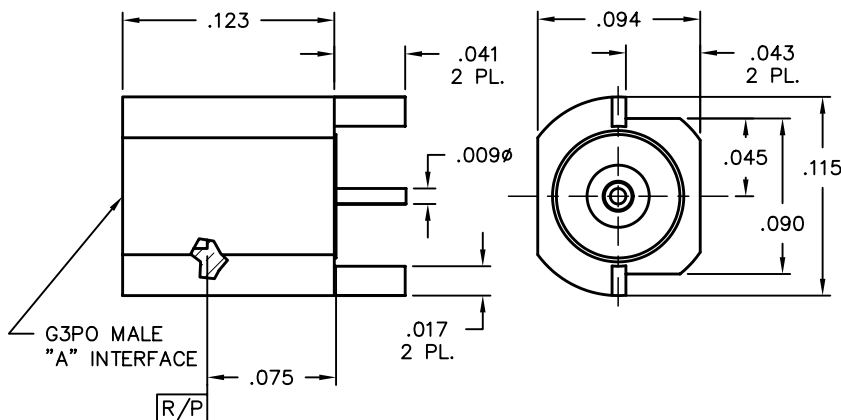

G3PO Surface Mounts

Male Smooth Bore Solder Attach Shroud

Catalog Number

R012-T95-01

Note: Recommended for use with Y071-L02-02

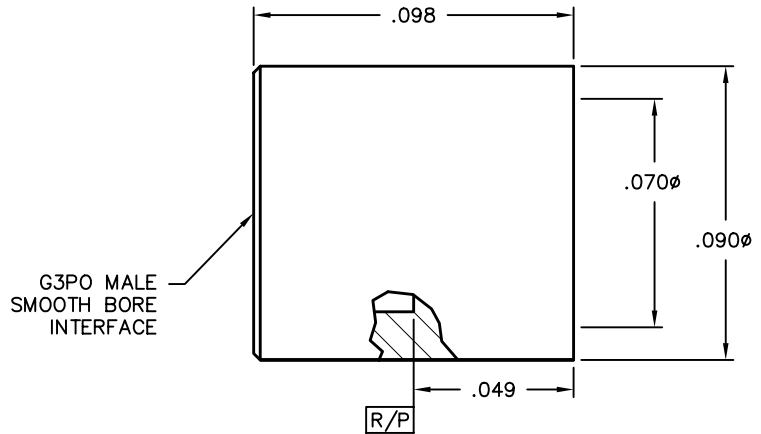

G3PO Hermetic Shrouds

Male Hermetic Shroud

Catalog Number

A

L Lengths

R007-L43-05-TAB-R FD .025/.030/.035/.040/.045/.050/.055/.060/.065/.070/.075

R007-L45-05-TAB-R SB .025/.030/.035/.040/.045/.050/.055/.060/.065/.070/.075

VSWR (TYP)

1.25:1 to 26.5 GHz

1.35:1 to 65 GHz

TAB: L x 10³ inches

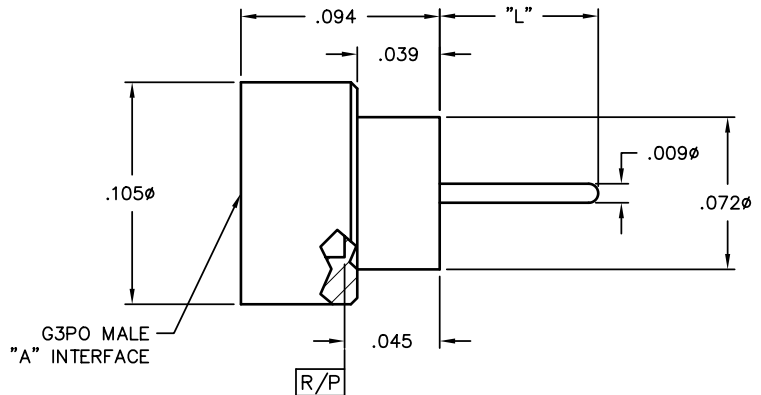

G3PO Loads

Female 50 Ohm Load

Catalog Number

R055-A11-01

VSWR (TYP)

1.20:1 to 18 GHz

1.30:1 to 40 GHz

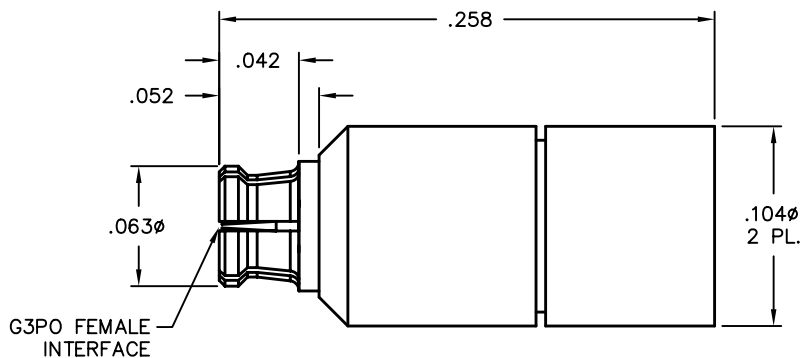

G3PO Loads

Female 50 Ohm Load

Catalog Number

R055-A11-02

VSWR (TYP)

1.20:1 to 18 GHz

1.30:1 to 40 GHz

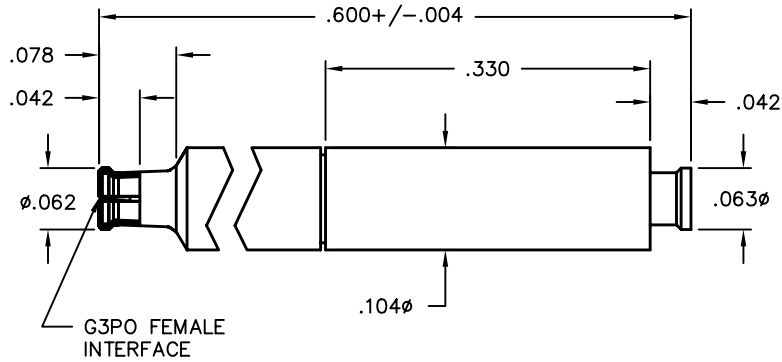

Male 50 Ohm Load

Catalog Number

R055-A13-01 FD

R055-A15-01 SB

VSWR (TYP)

1.20:1 to 18 GHz

1.30:1 to 40 GHz

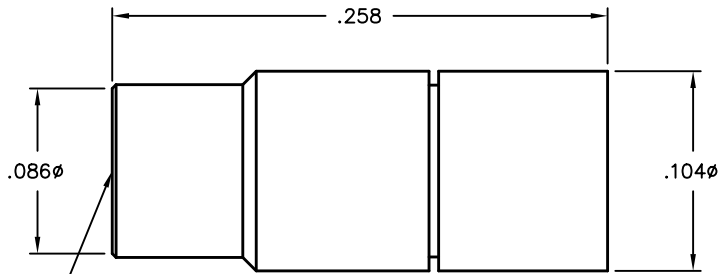

G3PO MALE
"A" INTERFACE



G3PO Pin

Surface Mount Pin

Catalog Number

Y071-L02-02

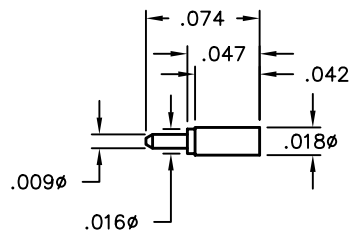

G3PO Multiposition Blocks

Male Smooth Bore 9-Position Mounting Block

Catalog Number

R036-T45-01

Mating Block:

R036-T43-01

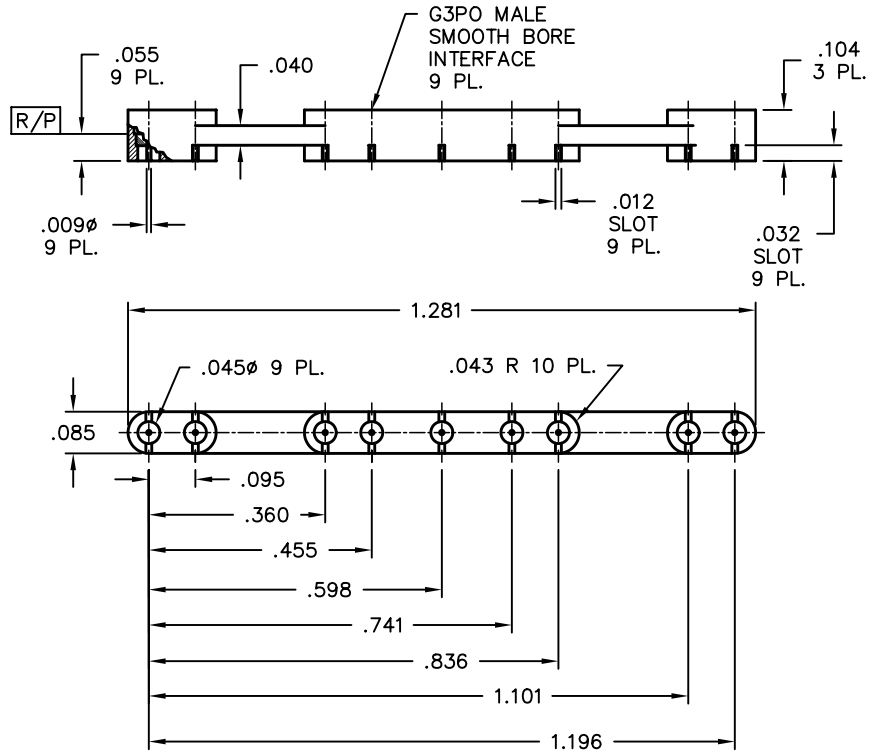

Short Interface Male Smooth Bore 5-Position Mounting Block 50 Ohm with 100 Ohm Washout

Catalog Number

R036-T45-02

Mating Block:

R036-T43-02

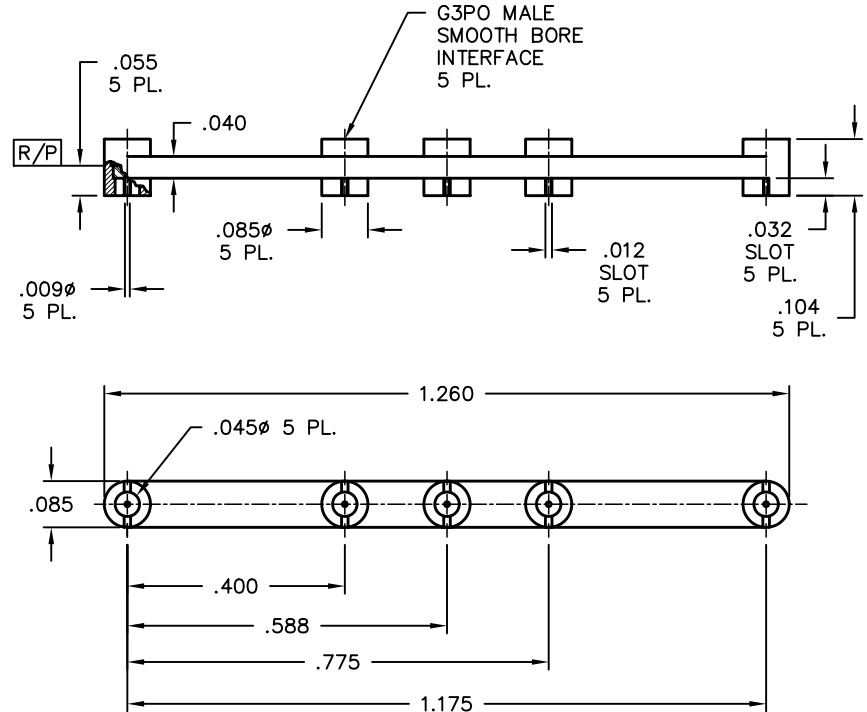

G3PO Multiposition Blocks

Male 6-Position Mounting Block

Catalog Number	A
R007-T43-01	FD
R007-T45-01	SB

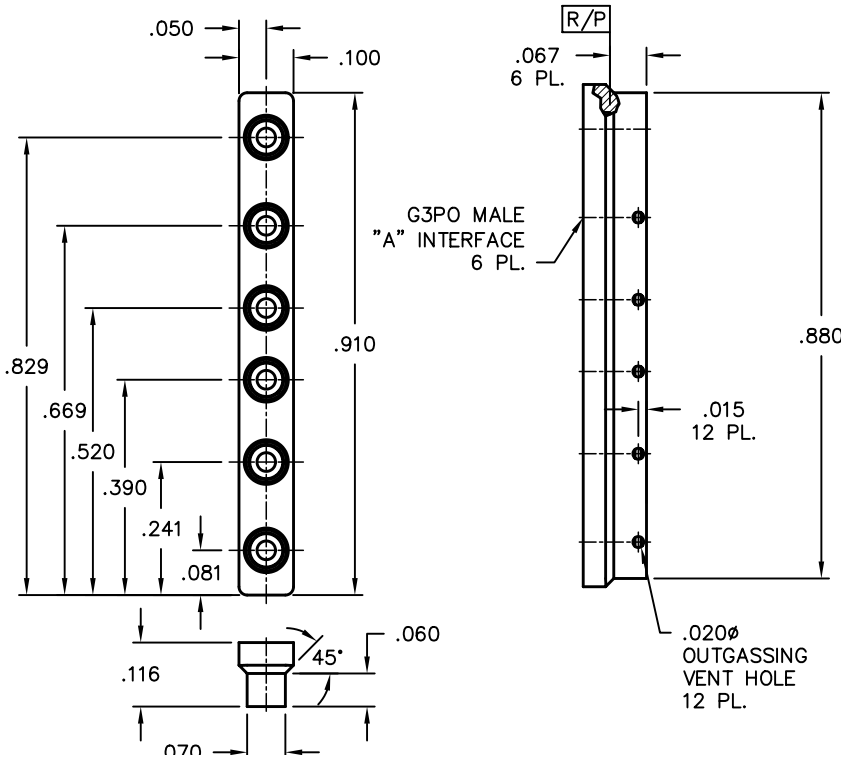

Male Full Detent 16-Position Block with Pins and Interface Plugs

Catalog Number
R036-T93-01

Mating Block:
R036-T95-02

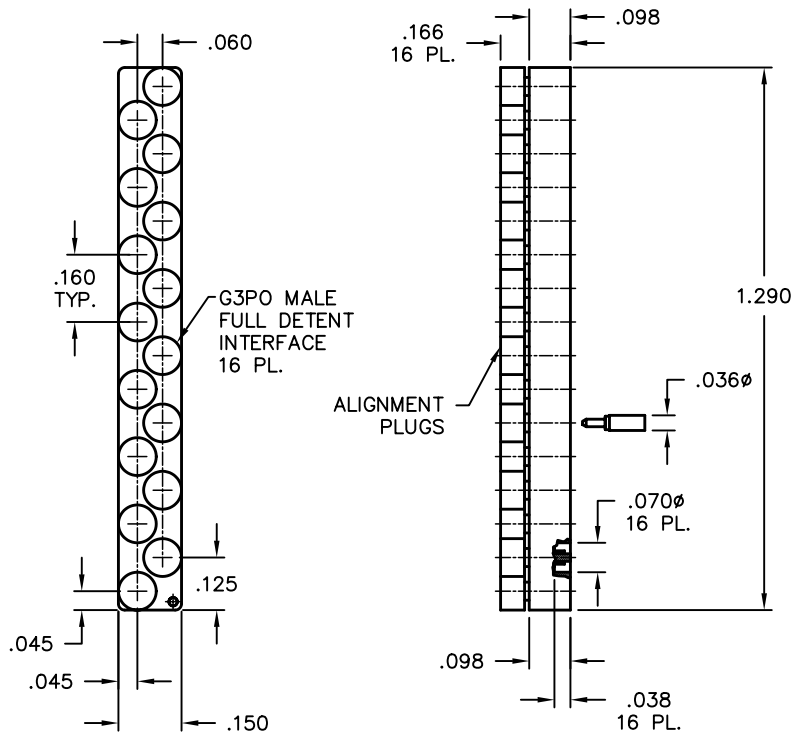

G3PO Multiposition Blocks

Male Smooth Bore 16-Position Block with Pins and Interface Plugs

Catalog Number

R036-T95-02

Mating Block:
R036-T93-01

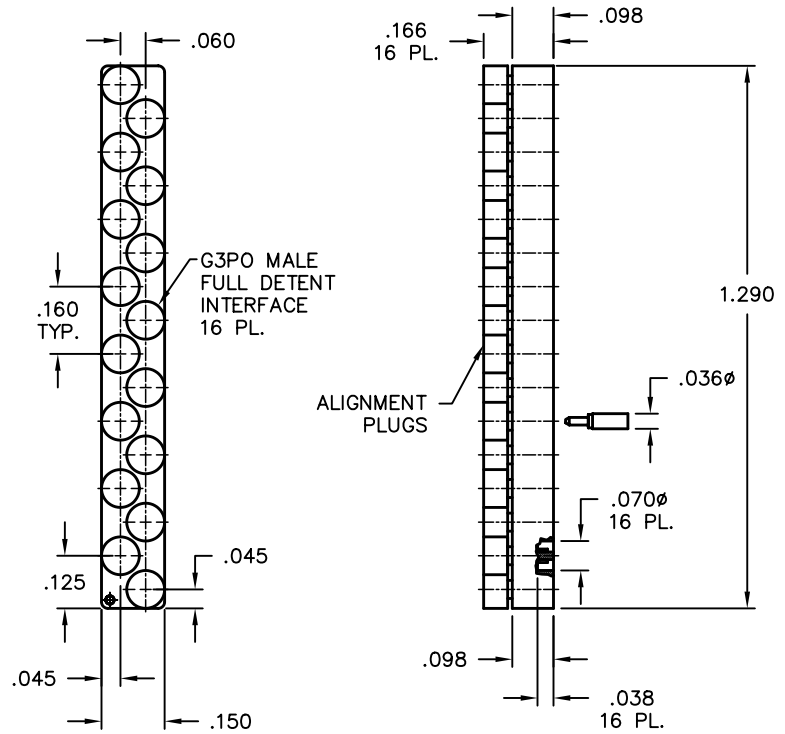

Male Full Detent 3-Position R/A Block

Catalog Number

R036-P93-01

Mating Block:
R036-P95-01

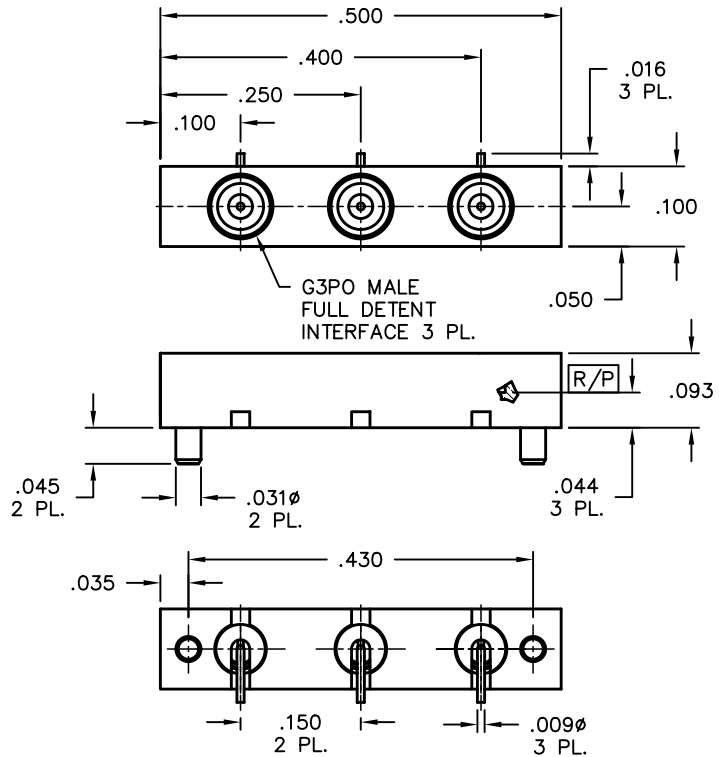

G3PO Multiposition Blocks

**Male Full Detent 16-Position
to 0.047 Cable, 2/56 Jackscrew Hardware**

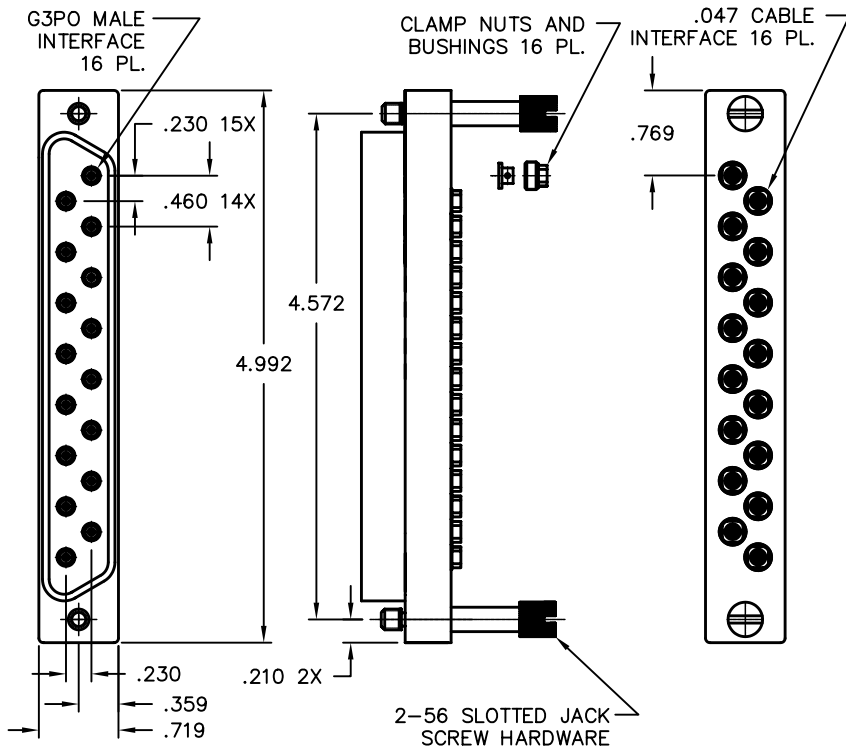

Catalog Number

R033-B53-01

Mating Block:

R032-L95-01

**Male Smooth Bore 16-Position PCB Mount
with Jackpost Hardware**

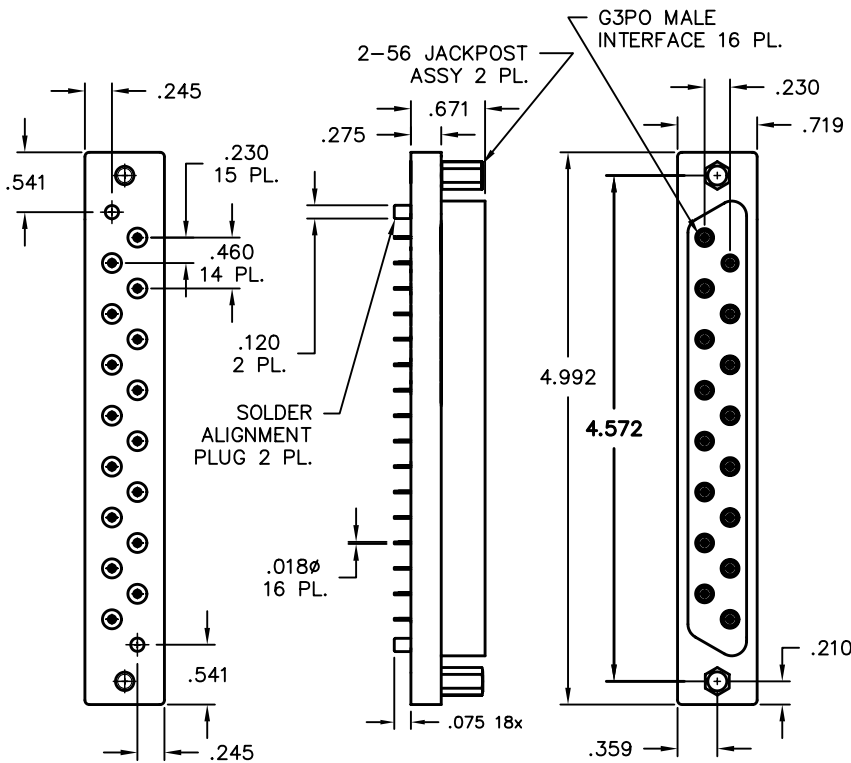

Catalog Number

R032-L95-01

Mating Block:

R033-B53-01

G3PO Multiposition Blocks

Male 2-Position Block

Catalog Number	A
R036-T93-05	FD
R036-T95-05	SB

Mating Block:
Each mates with the other

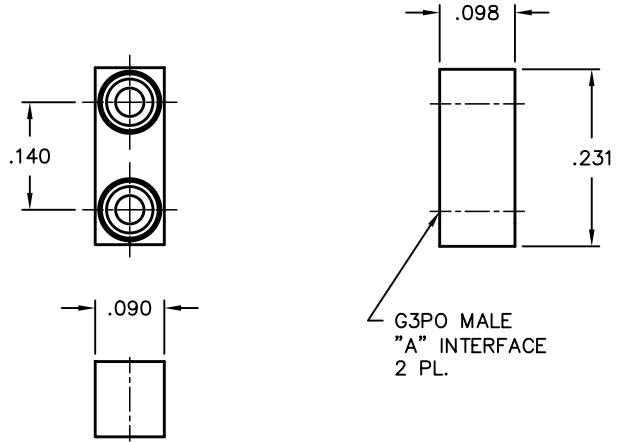

NOTES:

1. THE RECOMMENDED PIN CONTACT IS Y171-L02-02.

Male 4-Position Block

Catalog Number	A
R036-T93-06	FD
R036-T95-06	SB

Mating Block:
Each mates with the other

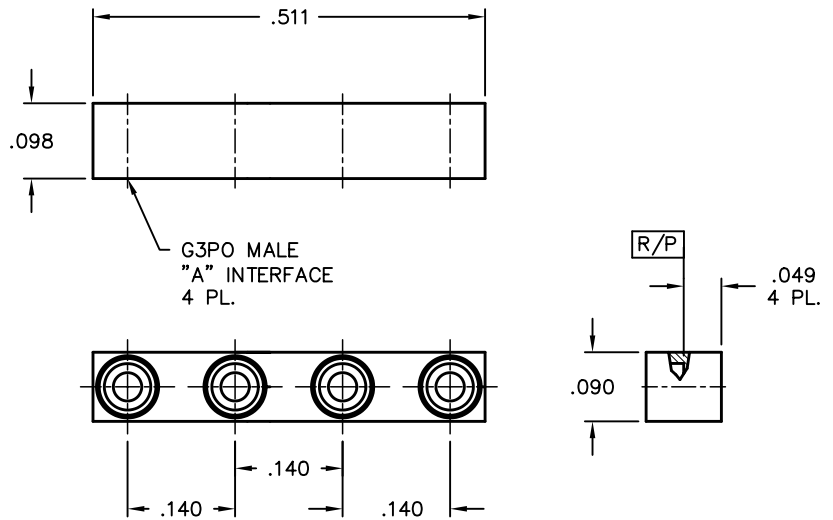

G3PO Multiposition Blocks

Male 6-Position Block

Catalog Number	A
R036-T93-07	FD
R036-T95-07	SB

Mating Block:
Each mates with the other

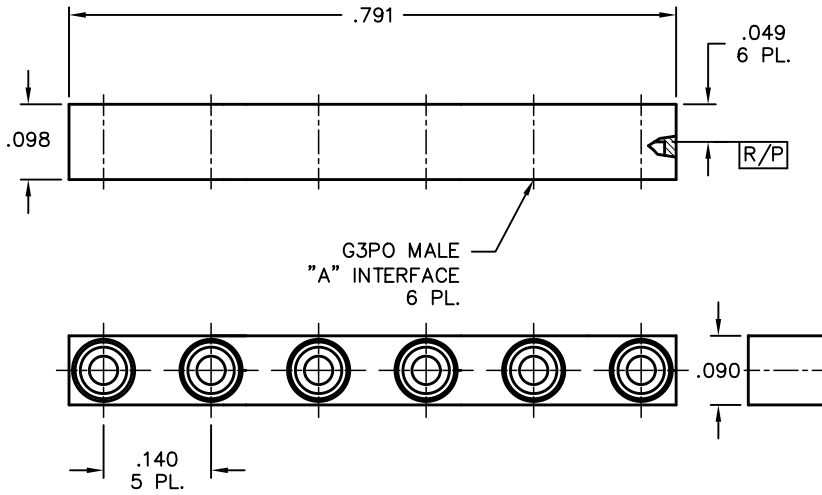

- NOTES:
1. THE RECOMMENDED PIN CONTACT IS Y171-L02-02.

NOTES

G4PO Products

- Center-to-center spacing of 0.070" and board-to-board spacing of 0.090" are available for increased package density
- Frequency from DC to 60 GHz
- Designed to accommodate both radial and axial misalignment with negligible VSWR change



G4PO® Specifications

General Characteristics

Impedance	50 ohms nominal
Frequency range	DC to 60 GHz
Temperature range	-55°C thru 165°C

Electrical Characteristics

VSWR	1.15:1 to 15 GHz typical; 1.25 : 1 typical to 60 GHz
Insertion loss	.03 √f (GHz)
DWV@ Sea Level:	250 Vrms
Insulation resistance	3,500 megohms min.
Contact resistance	
Outer conductor	2 milliohms max.
Inner conductor	6 milliohms max.
RF leakage	-80 dB (typical mated pair)

Mechanical Characteristics

Mate/Demate Cycles	Full Detent - 100min.; Smooth Bore - 500min.
Force to engage/disengage	Full Detent - .65lbs.typ./2.2lbs.typ.; SB - .20lbs.typ./1.15lbs.typ.
Tolerated misalignment	
Radial	+/- 0.005
Axial	0.007 (flush to 0.007 from the reference plane)

Environmental Characteristics

Thermal Shock	MIL-STD-202, Method 107, Condition B
Salt Spray	MIL-STD-202, Method 101
Vibration	MIL-STD-202, Method 204
Shock	MIL-STD-202, Method 213, Condition I
Moisture resistance	MIL-STD-202, Method 106, except Step 7B

Materials (typical)

Bodies	Beryllium Copper per ASTM B196 and or/ASTM B197
Outer contacts	Beryllium Copper per ASTM B196 and or/ASTM B197
Center contacts	Beryllium Copper per ASTM B196 and or/ASTM B197
Insulators	PTFE Fluorocarbon per ASTM D1710
Insulators	Polyamide-imide per ASTM D5204

Finish (typical)

Bodies	Gold plated per MIL-G-45204, Type I, Grade C, Class 1, Over Nickel Plate per SAE AMS-QQ-N-290
Contacts	Gold plated per MIL-G-45204, Type I, Grade C, Class 1, Over Nickel Plate per SAE AMS-QQ-N-290

G4PO Blindmate Interconnects

Female Blindmate Interconnect

Catalog Number	L Lengths
S1S1-0001-01-TAB	.065/.075/.080/.085/.090/.095/100

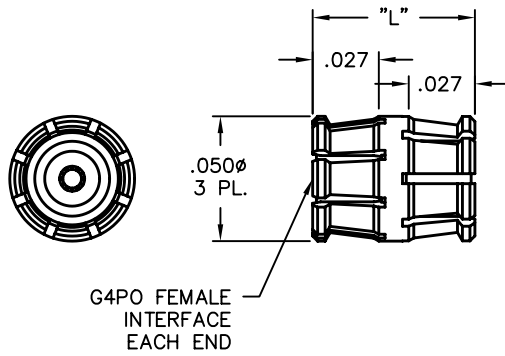

Female Blindmate Interconnect

Catalog Number	L Lengths
S1S1-0001-03-TAB	.105/.110/.115/.120/.200/.250/400

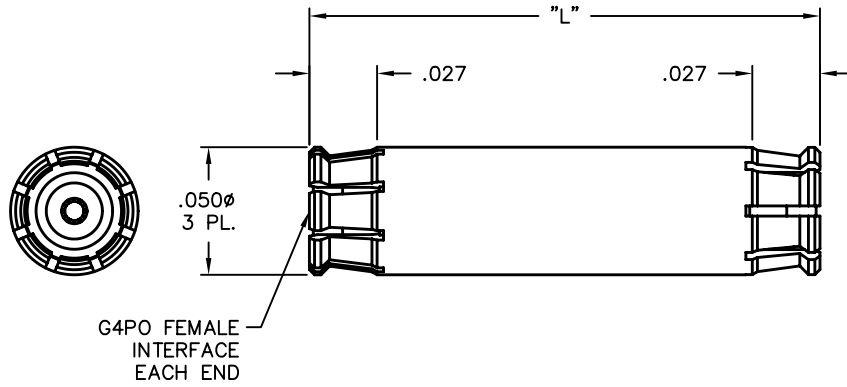

G4PO Cable Assemblies

G4PO Straight Female to G4PO Straight Female

Catalog Number

2-S1A-S1A-16-L0

G4PO R/A Female to G4PO R/A Female

Catalog Number

2-S1C-S1C-16-L

Other Cable Assembly Variations*:

2-S1C-D1A-16-L G4PO Female R/A to 2.92mm Female Straight to .041 Flex

2-S1A-S1C-16-L G4PO Female Straight to G4PO Female R/A to .041 Flex

2-S1A-D1A-16-L G4PO Female Straight to 2.92mm Female Straight to .041 Flex

* Please contact Customer Service for additional options not listed above.

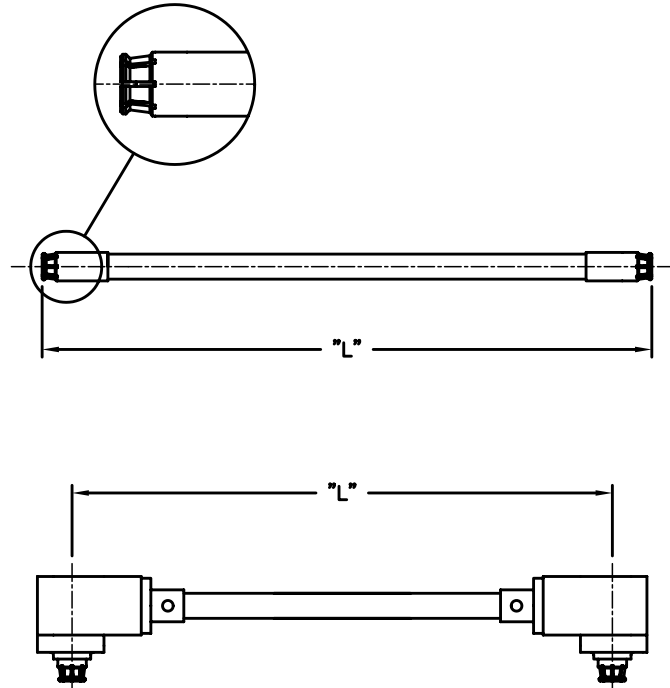

G4PO PCB Mounts

G4PO Male PCB Shroud with PCB Pin, Pre-Tinned

Catalog Number A

S008-L95-04-T SB

S008-L93-04-T FD

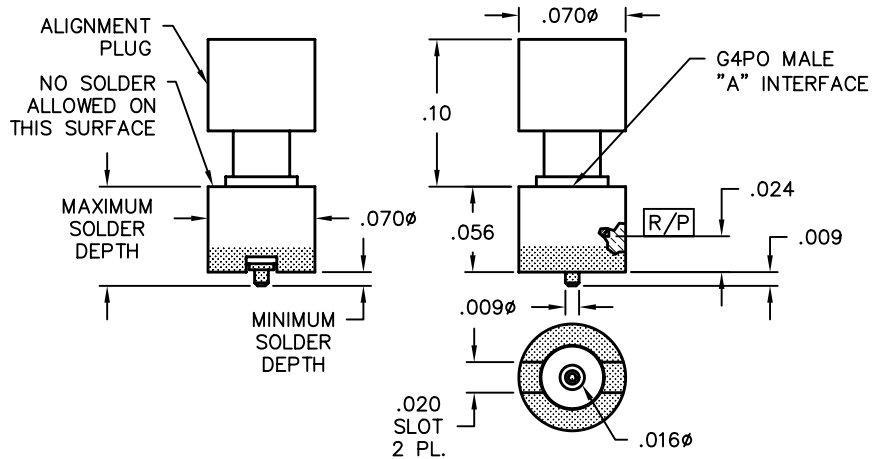

Full Detent Shown

G4PO PCB Mounts

G4PO-XD/SI* Male PCB Shroud with PCB Pin, Pre-Tinned

Catalog Number	A	B	C
S008-L95-03-T	SB	.062	XD
S008-L93-03-T	FD	.047	SI

* XD = Extra Deep
SI = Short Interface

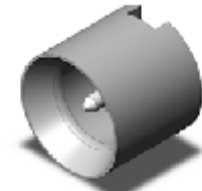
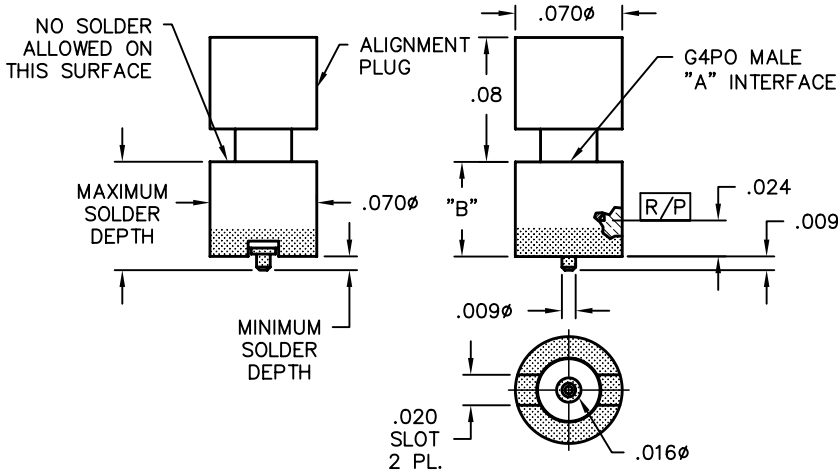

Smooth Bore Shown

G4PO Male Shroud and Pin, Pre-Tinned

Catalog Number	A
S007-L45-04-T	SB
S007-L43-04-T	FD

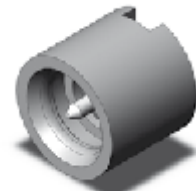
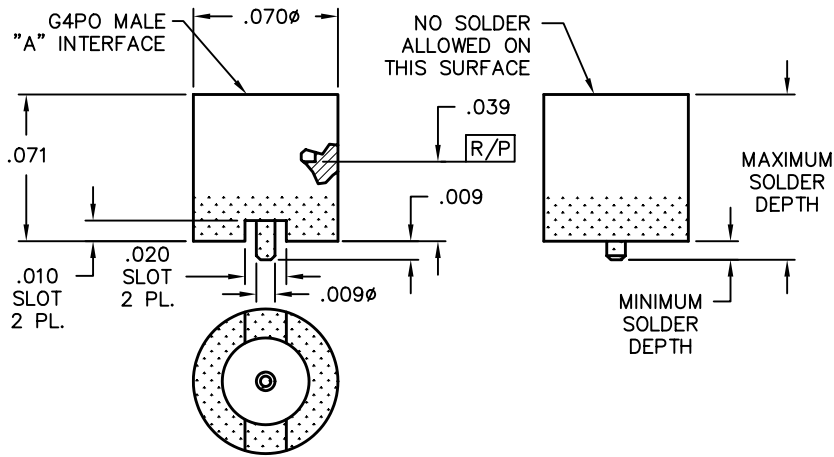

Full Detent Shown

G4PO-XD/SI* Male Shroud and Pin, Pre-Tinned

Catalog Number	A	B	C
S007-L45-03-T	SB	.077	XD
S007-L43-03-T	FD	.062	SI

* XD = Extra Deep
SI = Short Interface

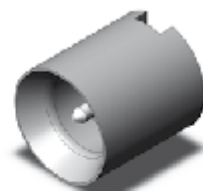
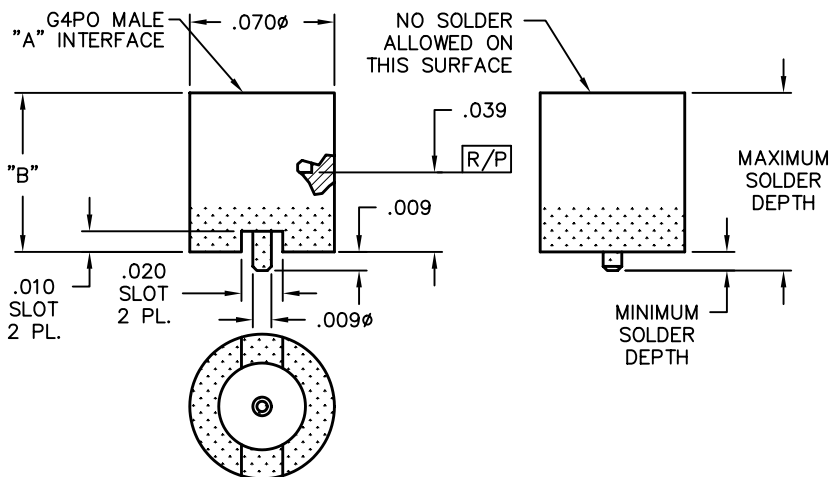

Smooth Bore Shown

G4PO Edge Mounts

G4PO PCB Edge Mount

Catalog Number	A
S010-L13-01	FD
S010-L15-01	SB

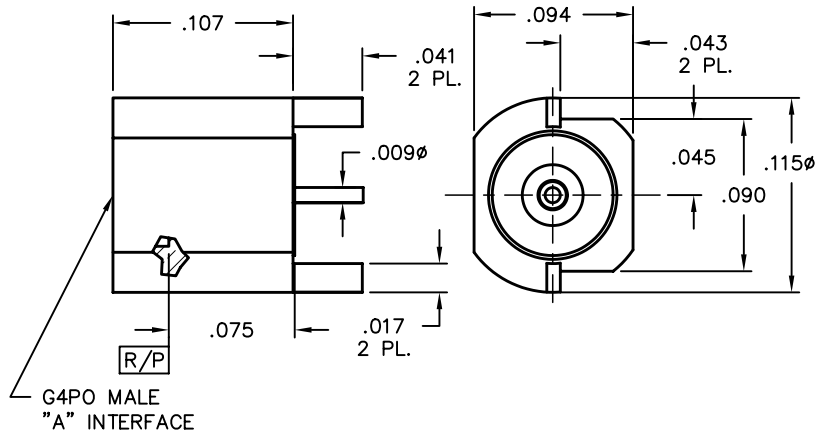
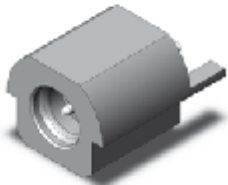

G4PO Surface Mounts

G4PO Male to PCB

Catalog Number	A
S012-T45-02	SB
S012-T43-02	FD



Full Detent Shown

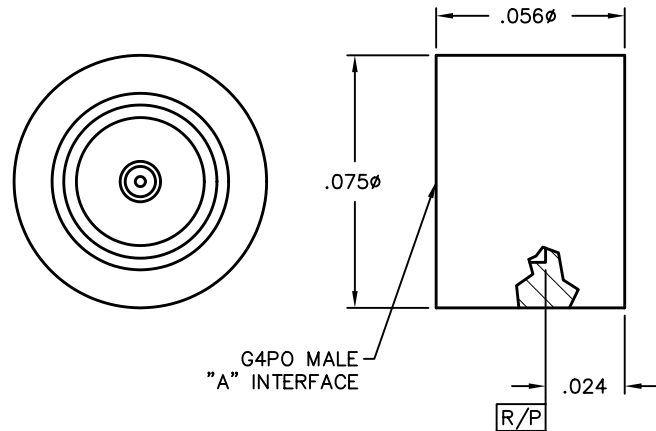

G4PO-XD/SI* Male to PCB

Catalog Number	A	B	C
S012-T45-01	SB	.062	XD
S012-T43-01	FD	.047	SI

* XD = Extra Deep
SI = Short Interface



Smooth Bore Shown

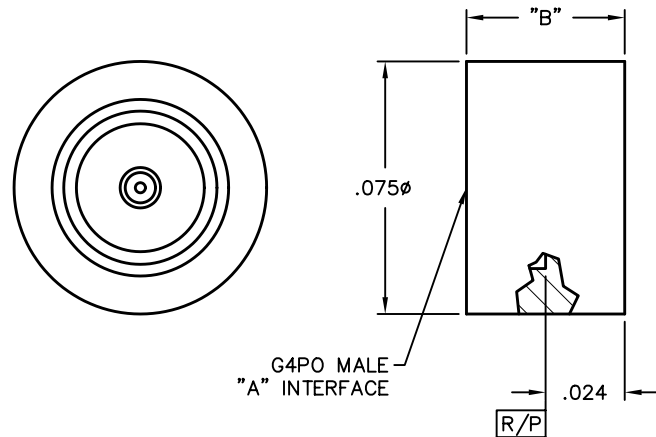

G4PO Hermetic Shroud

G4PO Male Solder-in Hermetic Shroud

Catalog Number	A	L Lengths
S007-L43-02-TAB-R	FD	.005 Increments up to .075
S007-L45-02-TAB-R	SB	.005 Increments up to .075

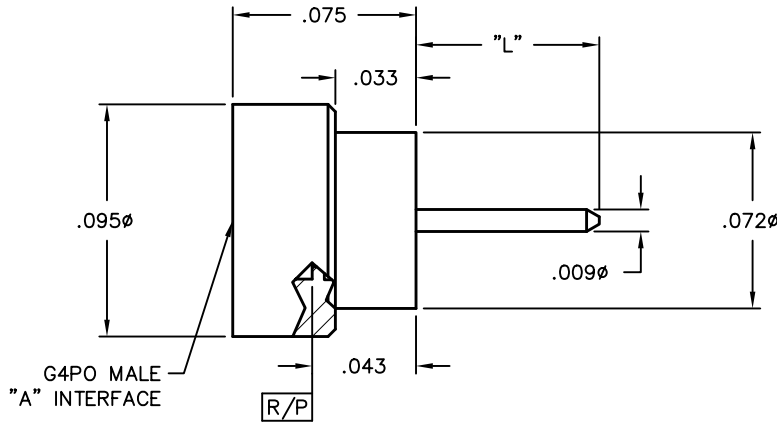

G4PO Multiposition Blocks

G4PO Male 2-Position PCB Shroud with Pins, Pre-Tinned

Catalog Number	A
S032-L95-02-T	SB
S032-L93-02-T	FD

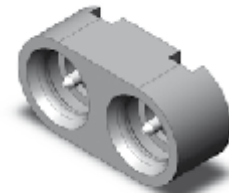
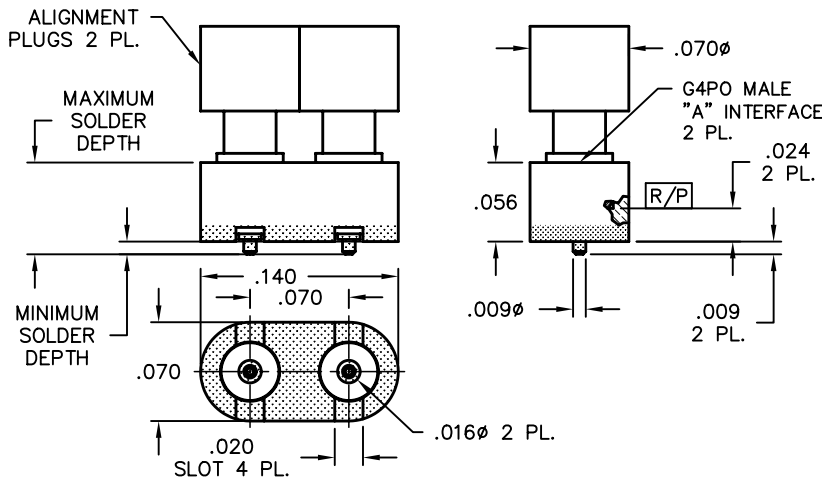

Full Detent Shown

G4PO-XD/SI* Male 2-Position PCB Shroud with Pins, Pre-Tinned

Catalog Number	A	B	C
S032-L95-01-T	SB	.062	XD
S032-L93-01-T	FD	.047	SI

Mating Block:
Each mates with the other

* XD = Extra Deep
SI = Short Interface

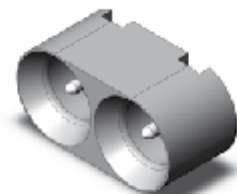
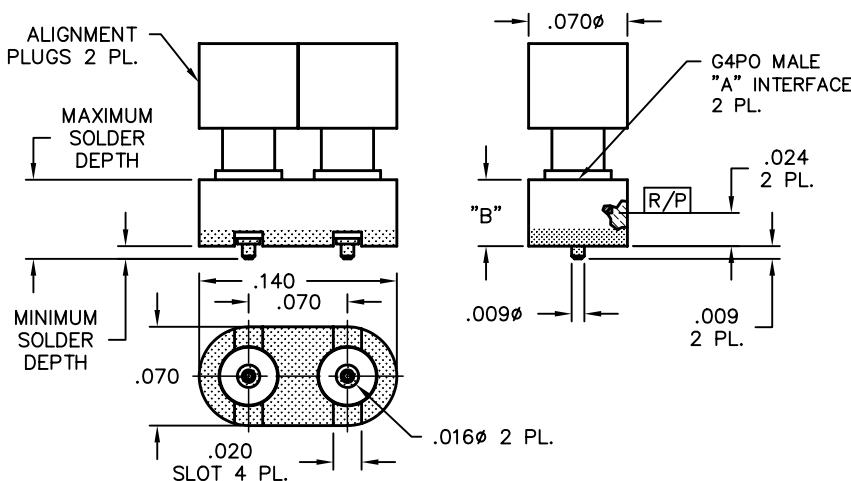

Smooth Bore Shown

G4PO Multiposition Blocks

G4PO Male 2-Position Surface Mount

Catalog Number	A
S036-T45-06	SB
S036-T43-06	FD

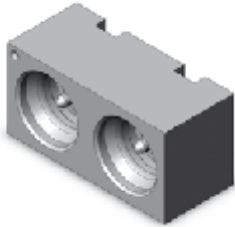

Full Detent Shown

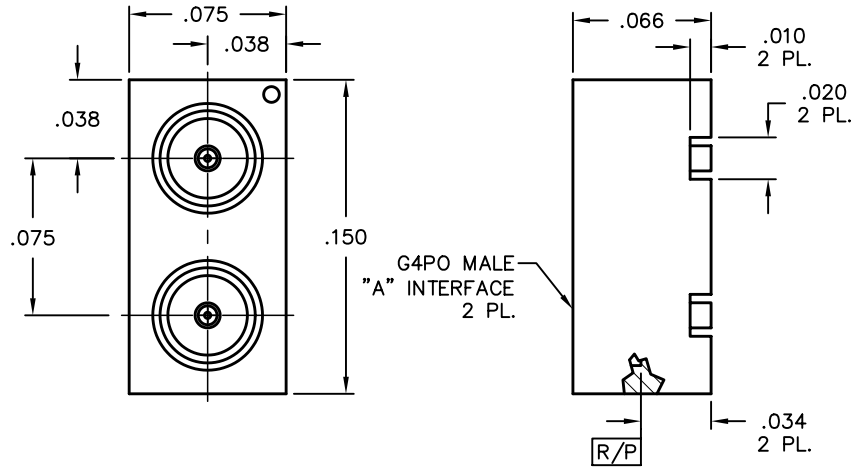

G4PO-XD/SI* Male 2-Position Surface Mount

Catalog Number	A	B	C	Washout
S036-T45-03	SB	.062	XD	NO
S036-T43-03	FD	.047	SI	NO
S036-T45-09	SB	.072	XD	YES
S036-T43-09	FD	.057	SI	YES

Mating Block:
Each mates with the other

* XD = Extra Deep
SI = Short Interface

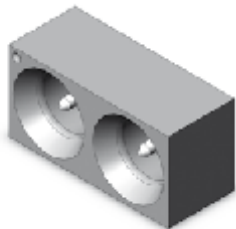

Smooth Bore Shown

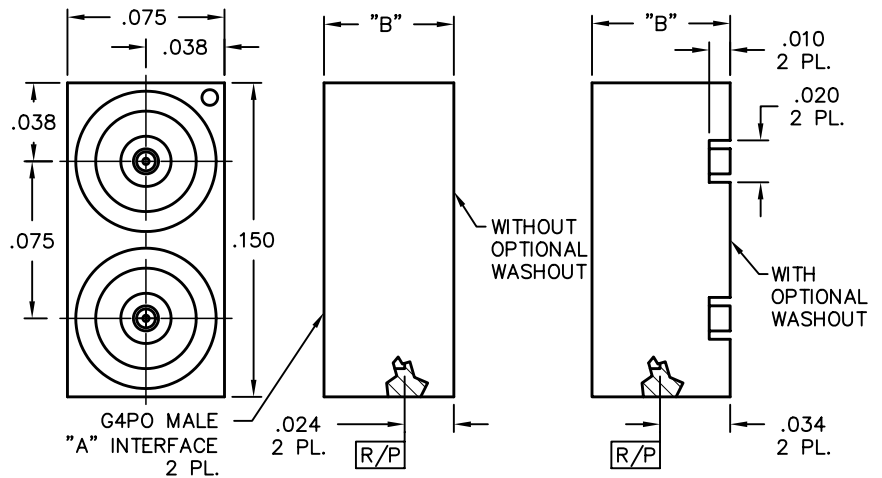

G4PO Multiposition Blocks

G4PO Male 6-Position Surface Mount

Catalog Number	A
S036-T45-07	SB
S036-T43-07	FD

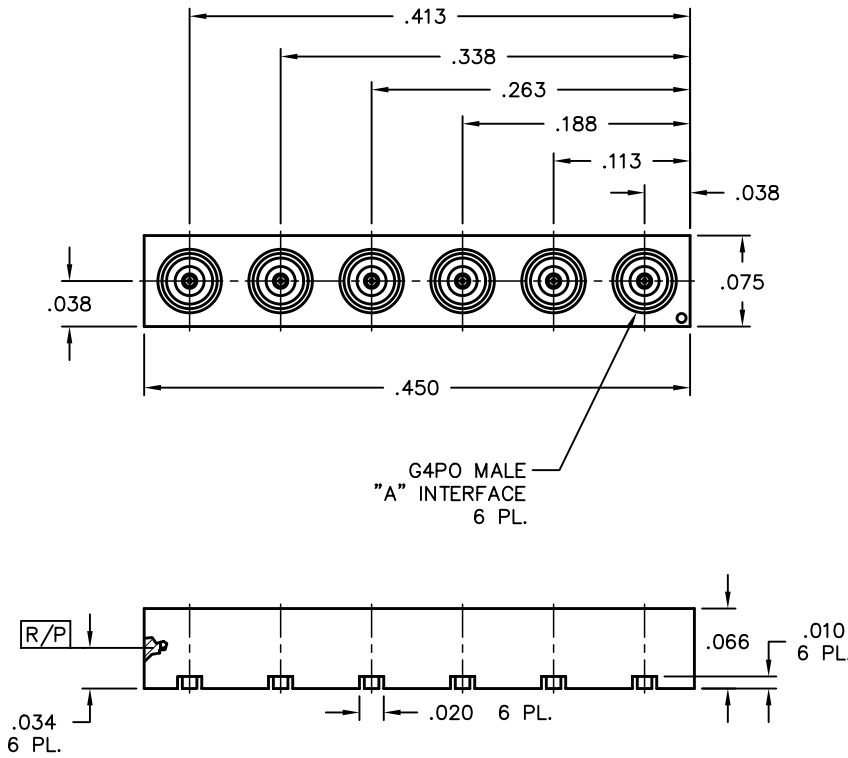

Full Detent Shown

G4PO-XD/SI* Male 6-Position Surface Mount

Catalog Number	A	B	C	Washout
S036-T45-04	SB	.062	XD	NO
S036-T43-04	FD	.047	SI	NO
S036-T45-10	SB	.072	XD	YES
S036-T43-10	FD	.057	SI	YES

Mating Block:
Each mates with the other

* XD = Extra Deep
SI = Short Interface

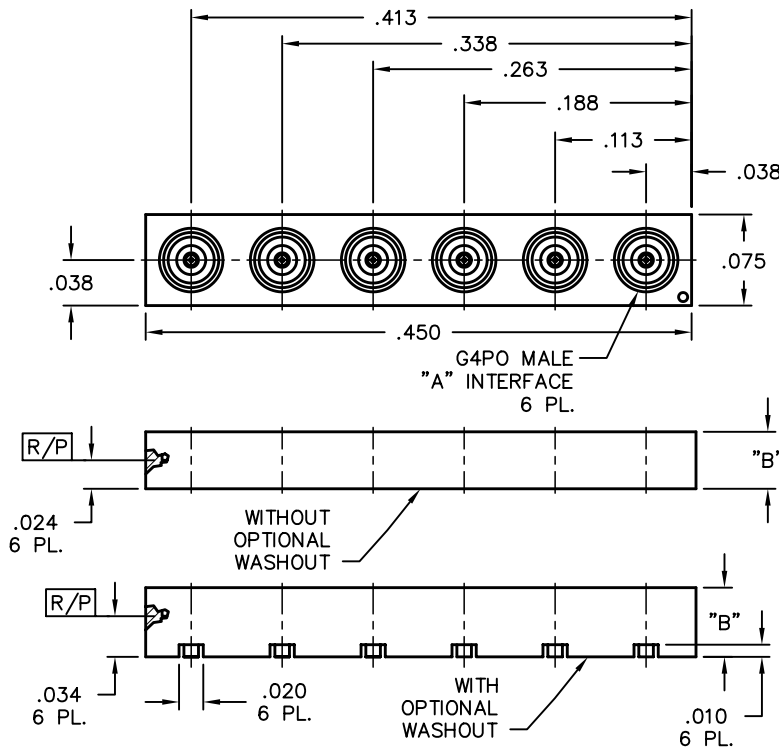

Smooth Bore Shown

G4PO Multiposition Blocks

G4PO Male 8-Position Surface Mount

Catalog Number	A
S036-T45-08	SB
S036-T43-08	FD



Full Detent Shown

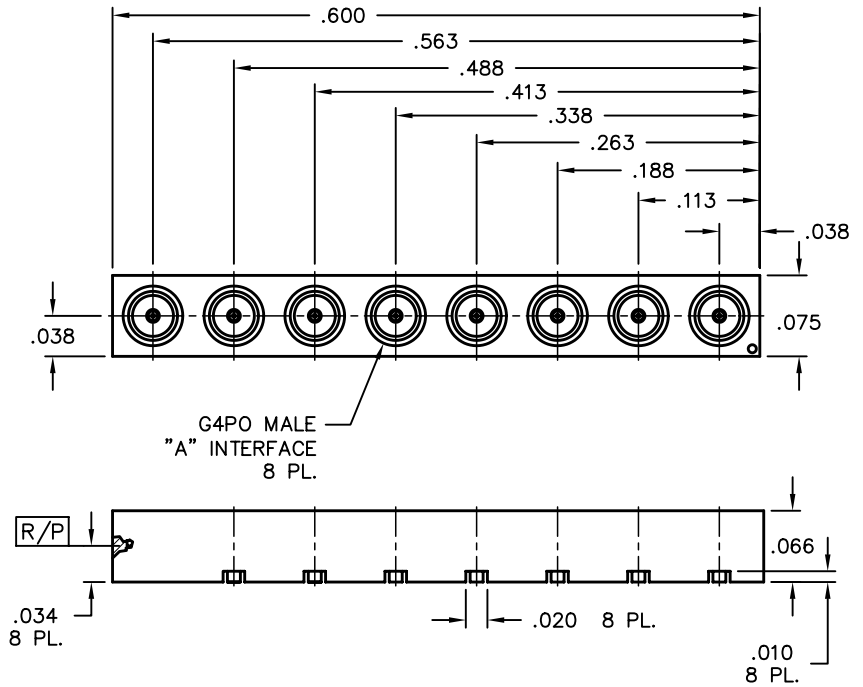

G4PO-XD/SI* Male 8-Position Surface Mount

Catalog Number	A	B	C	Washout
S036-T45-05	SB	.062	XD	NO
S036-T43-05	FD	.047	SI	NO
S036-T45-11	SB	.072	XD	YES
S036-T43-11	FD	.057	SI	YES

Mating Block:
Each mates with the other

* XD = Extra Deep
SI = Short Interface



Smooth Bore Shown

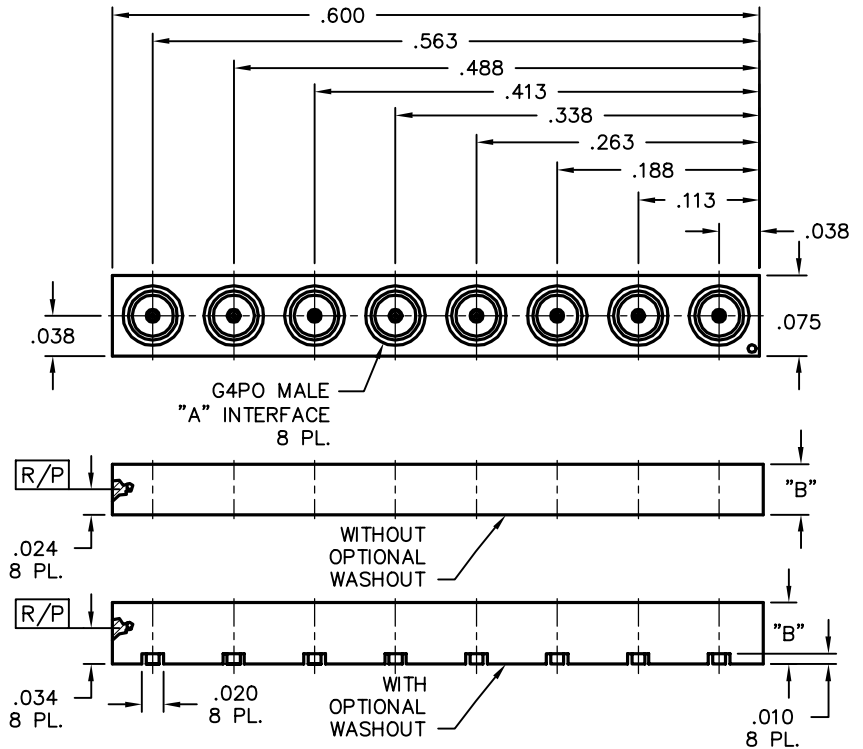

GMS Products

- Plug connector allows radial misalignment up to 0.020" and axial misalignment up to 0.060" without compromising electrical performance
- GMS® connectors are available in an ESD resistant version (see pp. 96-97)
- Frequency from DC to 23 GHz
- Designed to exceed 5000 engagements with negligible VSWR change
- Adapters available to GPO and SMA



GMS® Specifications

General Characteristics

Impedance	50 ohms nominal
Frequency range	DC to 23 GHz
Temperature range	-55°C thru 165°C

Electrical Characteristics

VSWR	1.20x.005x f(GHz) (typical mated pair)
Insertion loss	.05x √f (GHz)
DWV@ Sea Level:	1,500 Vrms
Insulation resistance	1,000 megohms min.
Contact resistance	
Outer conductor	2 milliohms max.
Inner conductor	2.5 milliohms max.
RF leakage	-80 dB (typical mated pair)

Mechanical Characteristics

Durability	5000+ mate/demate cycles
Force to engage/disengage	2.5 pounds typ.
Tolerated misalignment	
Radial	+/- .020
Axial	.060
Self-centering (male)*	

Environmental Characteristics

Thermal Shock	MIL-STD-202, Method 107, Condition B
Salt Spray	MIL-STD-202, Method 101
Vibration	MIL-STD-202, Method 204
Shock	MIL-STD-202, Method 213, Condition I
Moisture resistance	MIL-STD-202, Method 106, except Step 7B

Materials (typical)

Bodies	CRES 303 per ASTM A484 and ASTM A582 and or/ASTM A555 and ASTM A581
Outer contacts	Beryllium Copper per ASTM B196 and or/ASTM B197
Center contacts	Beryllium Copper per ASTM B196 and or/ASTM B197
Insulators	PTFE Fluorocarbon per ASTM D1710
Springs	17-7 Stainless Steel per ASTM A313-95A

Finish (typical)

Bodies	Passivate per MIL-F-14072 E300
Contacts	Gold plated per MIL-G-45204, Type I, Grade C, Class 1, Over Nickel Plate per SAE AMS-QQ-N-290

GMS Cable Connectors

Plug Float Mount to 0.086 S/R Cable

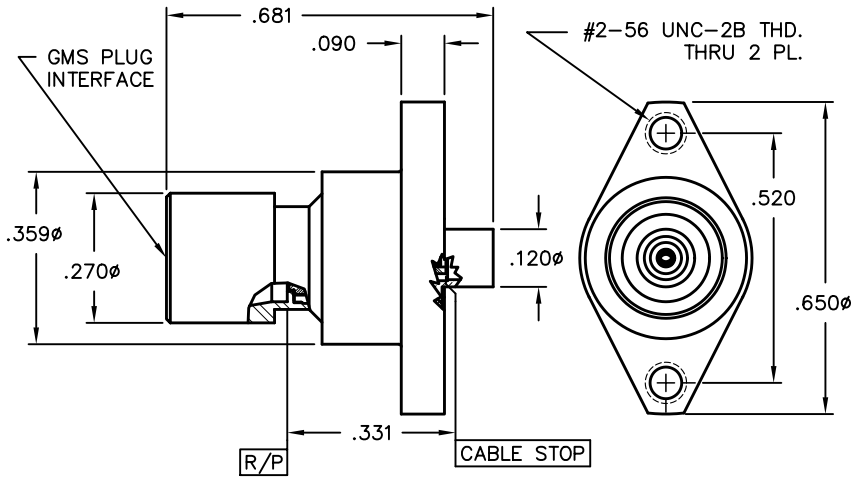

Catalog Number	Tools Recommended
H001-D32-01	H096-A99-01 L096-A99-01
VSWR (TYP)	Assembly Procedure
1.15:1 to 8 GHz	AP18-001
1.25:1 to 23 GHz	



Plug Snap-in Float Mount to 0.086 S/R Cable

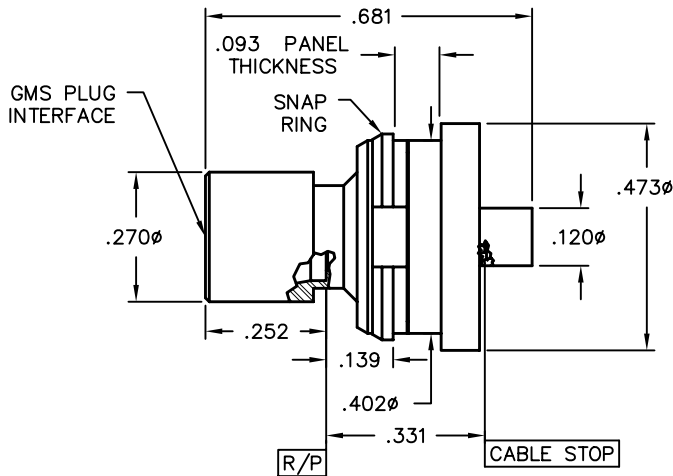

Catalog Number	Tools Recommended
H025-D32-01	H096-A99-01 L096-A99-01
VSWR (TYP)	Assembly Procedure
1.15:1 to 8 GHz	AP18-001
1.25:1 to 23 GHz	



Jack Bulkhead to 0.086 S/R Cable

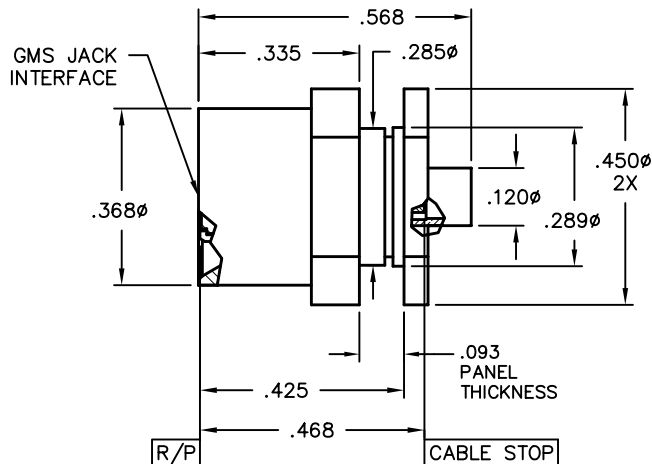

Catalog Number	Tools Recommended
H016-D11-01	A096-A99-09 L096-A99-01
VSWR (TYP)	Assembly Procedure
1.15:1 to 8 GHz	AP18-001
1.20:1 to 23 GHz	



GMS Cable Connectors

Jack Snap Mount to 0.086 S/R Cable

Catalog Number
H025-D11-01

VSWR (TYP)
1.30:1 to 23 GHz

Tools Recommended
A096-A99-09
L096-A99-01

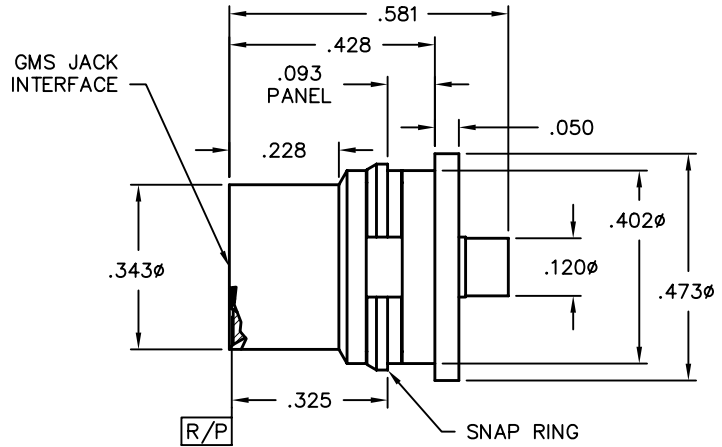

**Plug Float Mount R/A Flange Mount
Accepts 0.141 S/R Cable**

Catalog Number **Assembly Procedure**
H019-R32-01 AP18-009

Tools Recommended
H096-A99-01
L096-A99-10

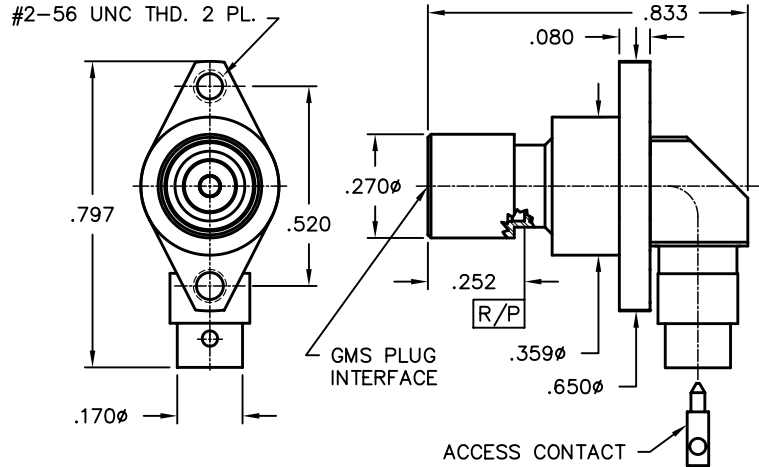

**Plug Snap-in Float Mount
to 0.141 Low Loss Cable**

Catalog Number **Assembly Procedure**
H018-S32-01 AP18-019

Tools Recommended
H096-A99-01
L096-A99-10

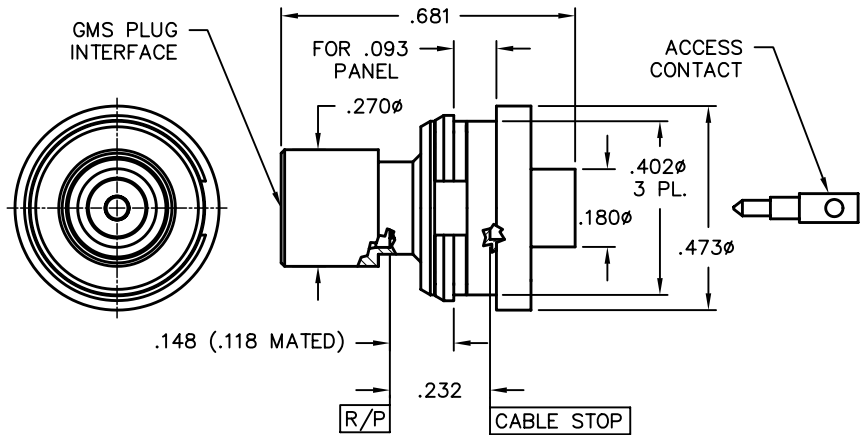

GMS Cable Connectors

Plug 2 Hole Flange Float Mount to 0.141 Cable

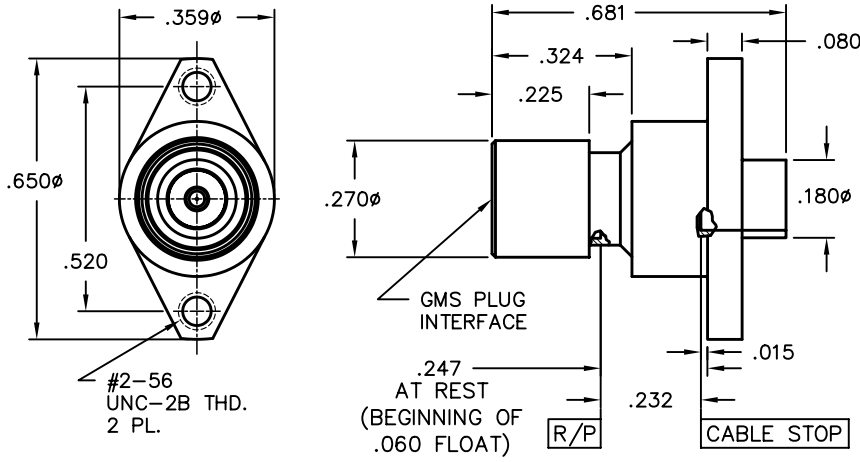

Catalog Number	Tools Recommended
H001-R32-01	H096-A99-01
VSWR (TYP)	L096-A99-10
1.14:1 to 18 GHz	Assembly Procedure
1.35:1 to 23 GHz	AP18-002



Jack Bulkhead to 0.141 S/R Cable

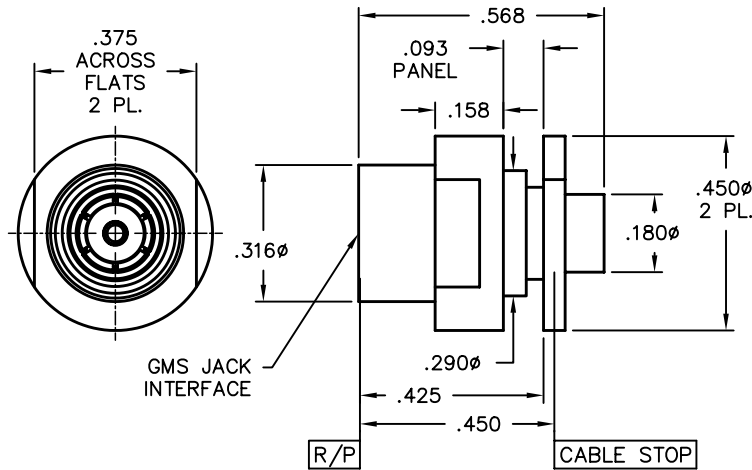

Catalog Number	Tools Recommended
H016-R11-01	A096-A99-09
VSWR (TYP)	L096-A99-10
1.20:1 to 23 GHz	Assembly Procedure
	AP18-002



Plug Float Mount to 160 Flex Cable

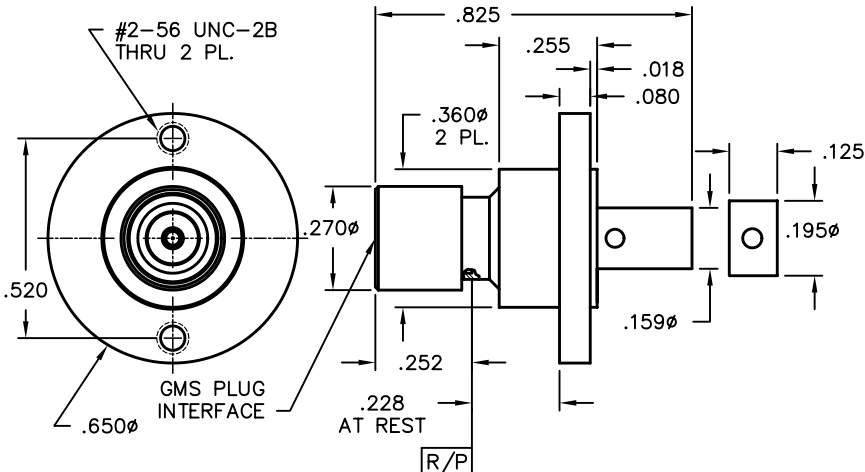

Catalog Number
H018-K32-01



GMS Cable Connectors

Size 5 Plug to 160 Cable

Catalog Number
H018-K12-01

Assembly Procedure
AP18-015

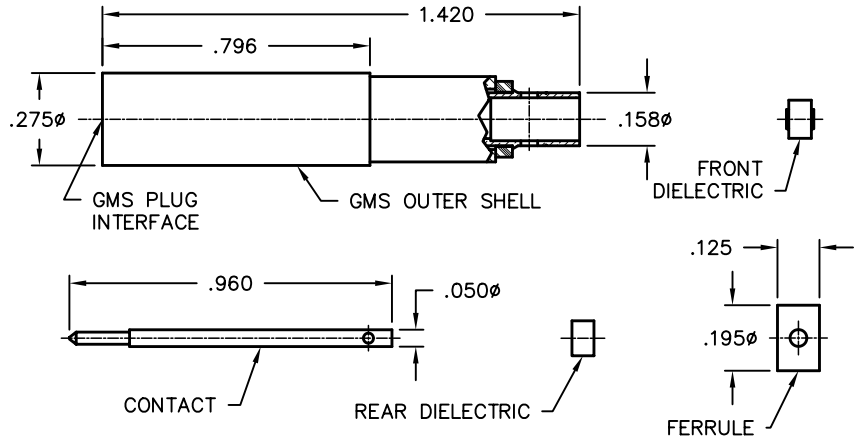

Size 5 Jack to 160 Cable

Catalog Number
H014-K11-01

Assembly Procedure
AP18-011

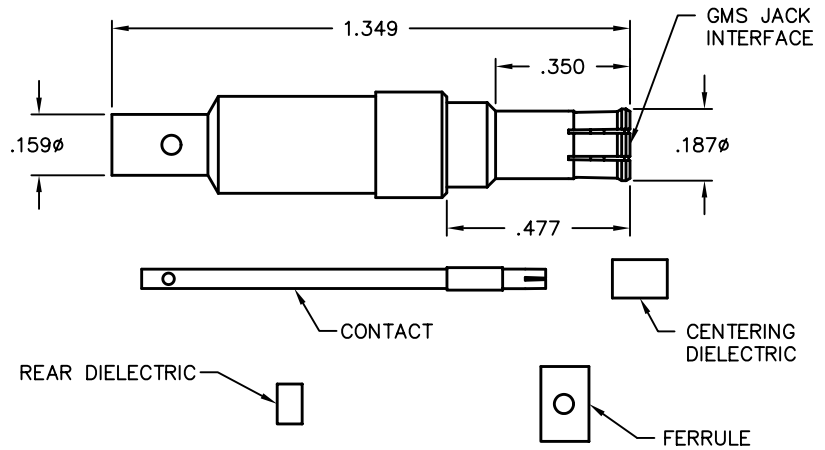

GMS Flange Mounts

Jack 2 Hole Flange Mount
Accepts 0.015 C/C

Catalog Number
H001-N11-01

VSWR (TYP)
1.20:1 to 15 GHz
1.30:1 to 23 GHz

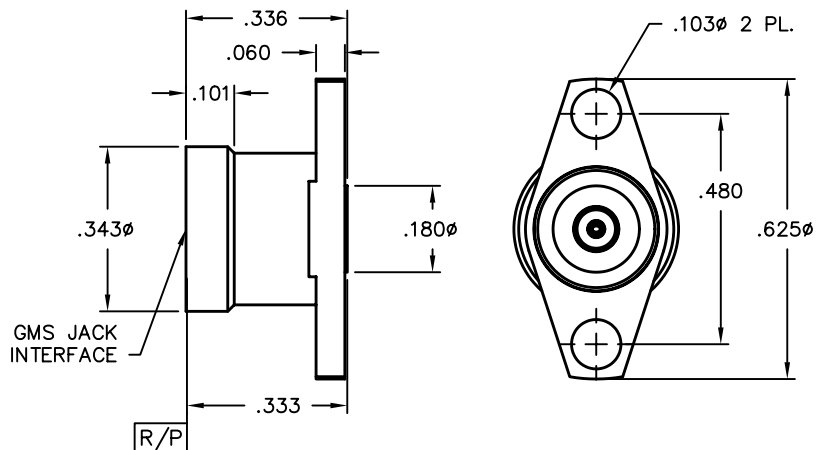

GMS Flange Mounts

Jack 2 Hole Flange to Post Terminal

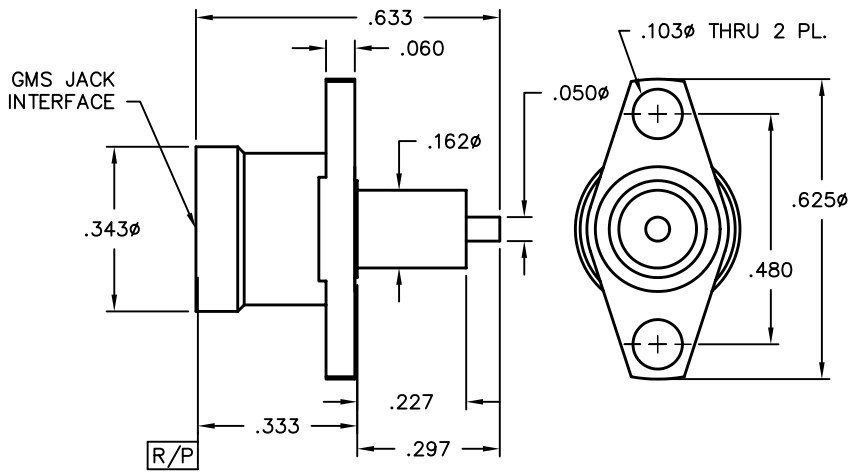

Catalog Number

H001-L11-01

VSWR (TYP)

1.20:1 to 15 GHz

1.30:1 to 23 GHz



GMS Loads

Plug 50 Ohm Load Float Mount

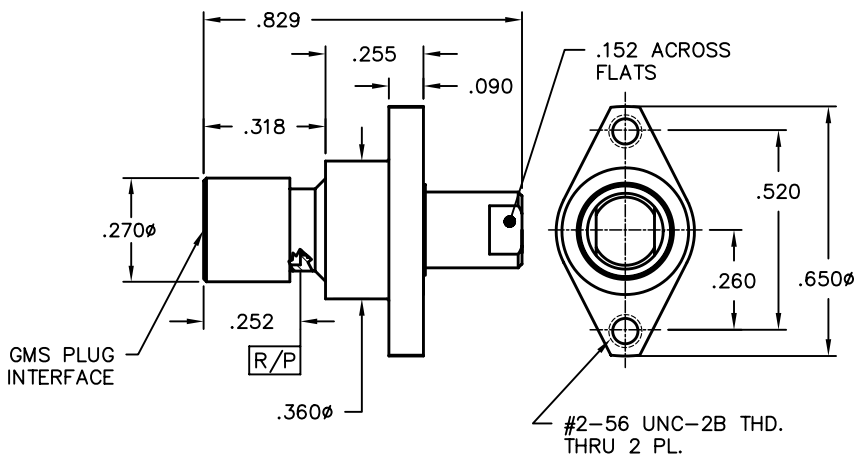

Catalog Number

H055-A12-01

VSWR (TYP)

1.15:1 to 18 GHz

1.35:1 to 23 GHz



GMS Flange Mounts

Jack 50 Ohm Load Bulkhead

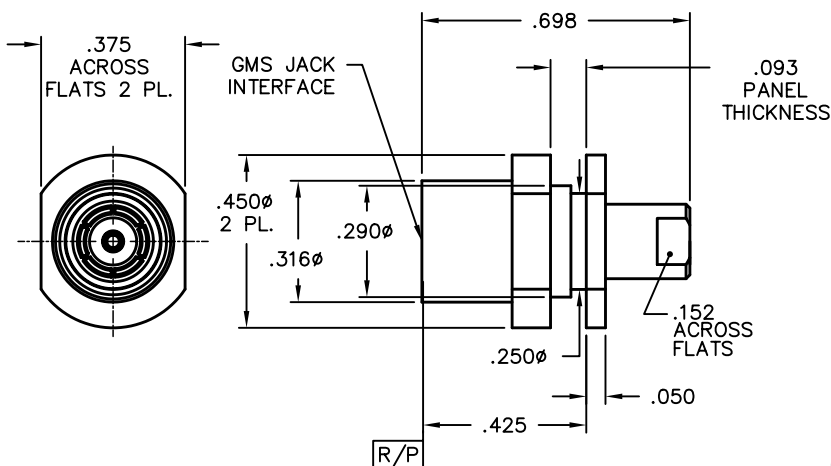

Catalog Number

H055-A11-01

VSWR (TYP)

1.15:1 to 15 GHz

1.30:1 to 23 GHz

GMS ESD Flange Mounts

Jack 2 Hole Flange Mount to Tab Terminal

Catalog Number

H001-M11-02

H001-M11-03 (Contains Internal Gasket)

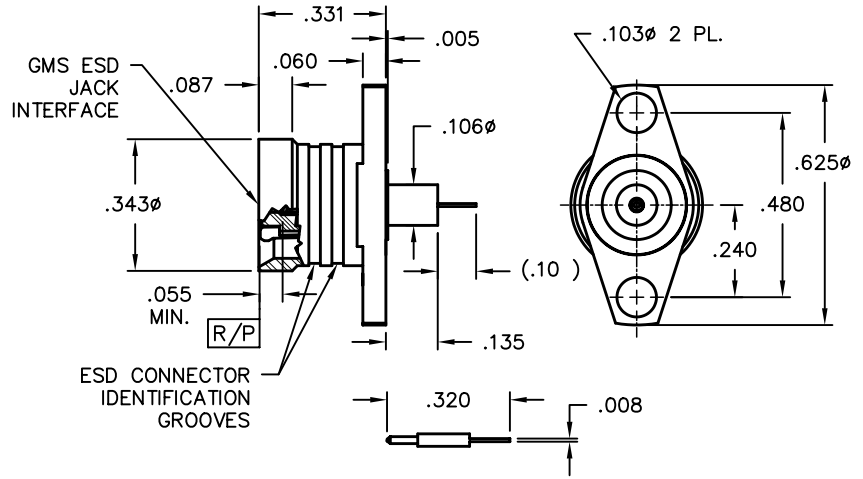

Jack 2 Hole Flange Mount Accepts 0.015 C/C

Catalog Number

H001-N11-04

H001-N11-05 (Contains Internal Gasket)

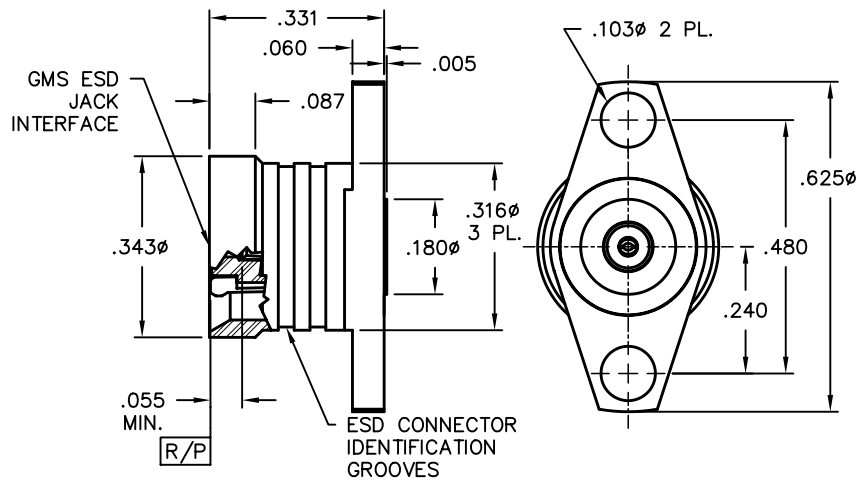

GMS ESD Cable Connectors

Jack 2 Hole Flange Mount Rotator to 0.047 S/R Cable

Catalog Number

H014-B31-01

Tools Recommended

A096-A99-09

VSWR (TYP)

1.35:1 to 15 GHz

A096-A99-02

Assembly Procedure

1.40:1 to 23 GHz

AP18-022

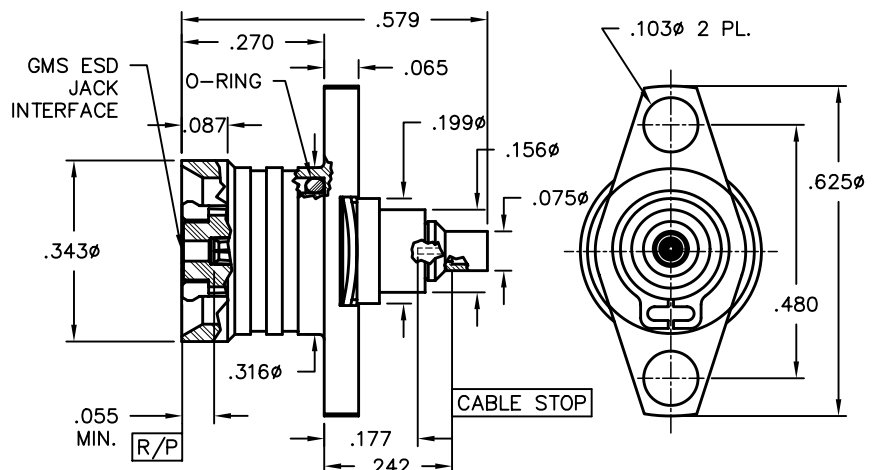

GMS ESD Cable Connectors

Plug 2 Hole Float Mount to 0.086 S/R Cable

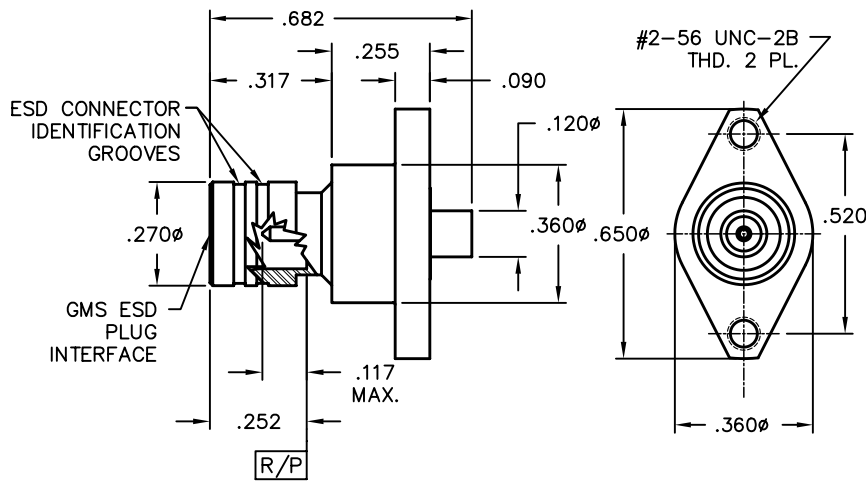

Catalog Number A

H018-D32-07	0.090
H018-D32-06	0.080

Tools Recommended

H096-A99-01
L096-A99-01

Assembly Procedure

AP18-001



Plug 2 Hole Float Mount to 0.141 S/R Cable

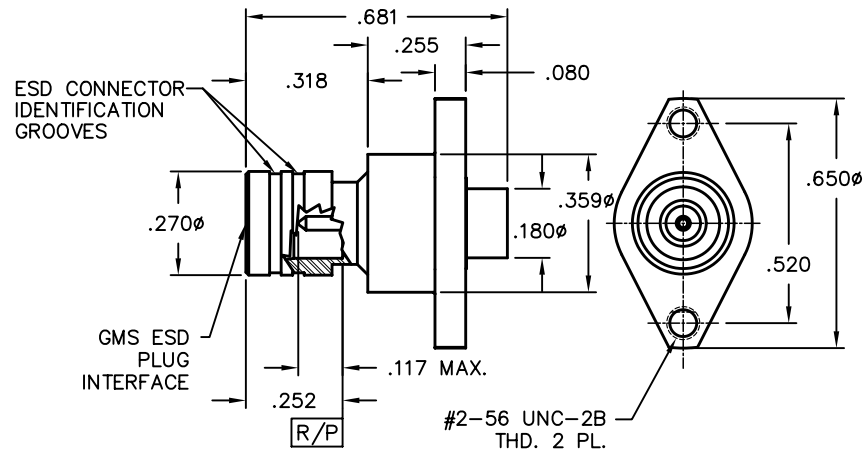

Catalog Number

H018-R32-02

Tools Recommended

H096-A99-01
L096-A99-10

GMS ESD Load

Plug 50 Ohm Load 2 Hole Flange Mount

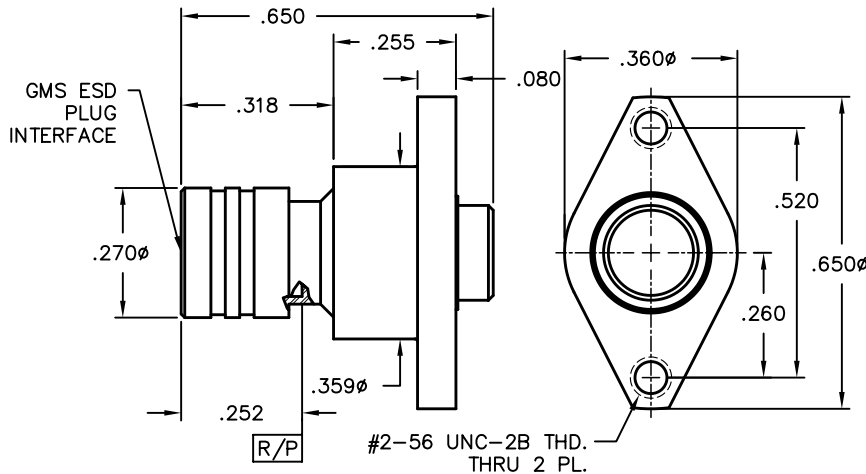

Catalog Number

H055-A32-02



NOTES

SGMS Products

- Center-to-center spacing of 0.250" available for increased package density
- Frequency from DC to 23 GHz
- Designed to accommodate both radial and axial misalignment with negligible VSWR change



SGMS™ Specifications

General Characteristics

Impedance	50 ohms nominal
Frequency range	DC to 23 GHz
Temperature range	-65°C thru 165°C

Electrical Characteristics

VSWR	1.15:1 to 23 GHz typical
Insertion loss	.05 √f (GHz)
DWV@ Sea Level:	1,500 Vrms
Insulation resistance	1,000 megohms min.
Contact resistance	
Outer conductor	2 milliohms max.
Inner conductor	6 milliohms max.
RF leakage	-80 dB to 3 GHz, -65dB to 23 GHz

Mechanical Characteristics

Durability	5000+ mate/demate cycles
Force to engage/disengage	LD - 4.5 lbs typ./6.0 lbs. typ. SB - 3.0 lbs typ./ 1.5 lbs. typ.
Tolerated misalignment	
Radial	+/- .020
Axial	.020 (flush to .020 from the reference plane)

Environmental Characteristics

Thermal Shock	MIL-STD-202, Method 107, Condition B
Salt Spray	MIL-STD-202, Method 101
Vibration	MIL-STD-202, Method 204
Shock	MIL-STD-202, Method 213, Condition I
Moisture resistance	MIL-STD-202, Method 106, except Step 7B

Materials (typical)

Bodies	CRES 303 per ASTM A484 and ASTM A582 and or/ASTM A555 and ASTM A581
Outer contacts	Beryllium Copper per ASTM B196 and or/ASTM B197
Center contacts	Beryllium Copper per ASTM B196 and or/ASTM B197
Insulators	PTFE Fluorocarbon per ASTM D1710
Springs	17-7 Stainless Steel per ASTM A313-95A

Finish (typical)

Bodies	Passivate per MIL-F-14072 E300
Contacts	Gold plated per MIL-G-45204, Type I, Grade C, Class 1, Over Nickel Plate per SAE AMS-QQ-N-290

SGMS Blindmate Interconnect

Female Blindmate Interconnect

Catalog Number

1881-001-1

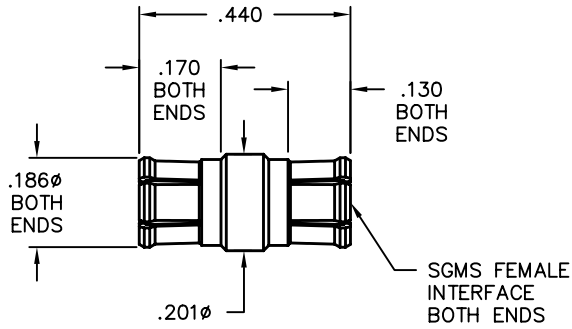

SGMS Cable Connectors

Plug Limited Detent High Average Power Mount to 0.141 S/R

Catalog Number

6804-100-3

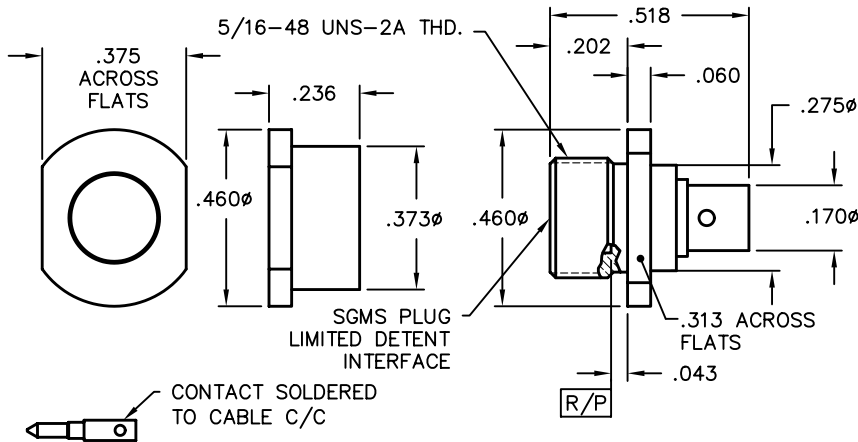

Plug 2-Hole Flange Mount for 120 Cable

Catalog Number A

P001-K94-01 LD

P001-K95-01 SB

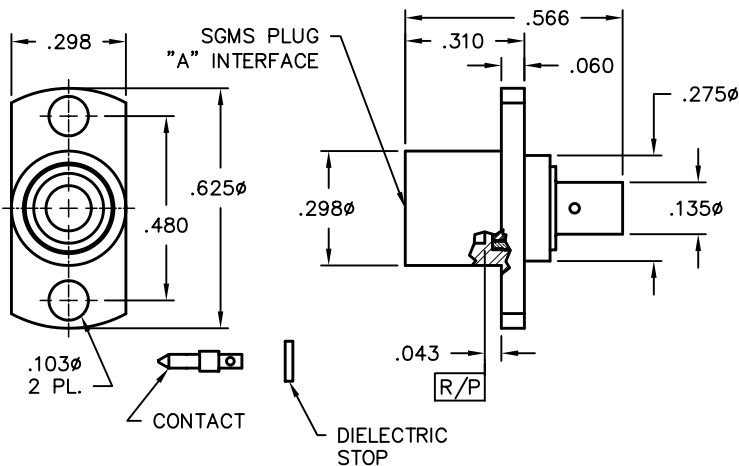

SGMS Cable Connectors

Plug Snap-in Mount to HP120 Cable

Catalog Number	A
P016-K94-01	LD
P016-K95-01	SB

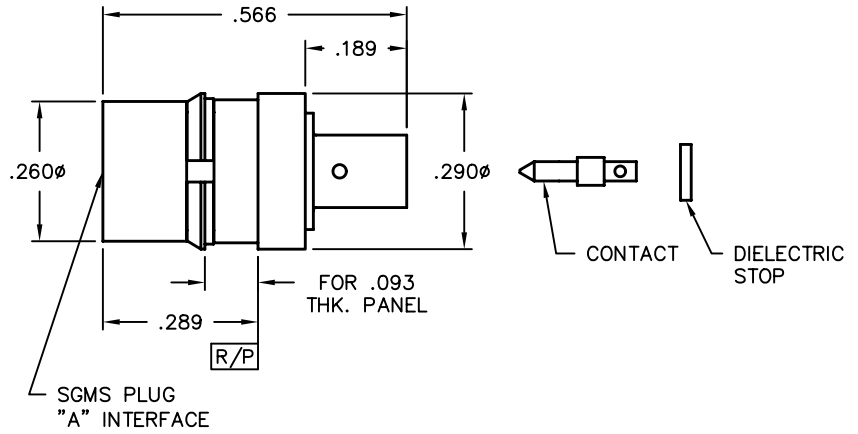

SGMS Flange Mounts

Plug 4 Hole Flange Mount Tab Terminal

Catalog Number	A
1811-400-3	SB
1811-401-3	LD

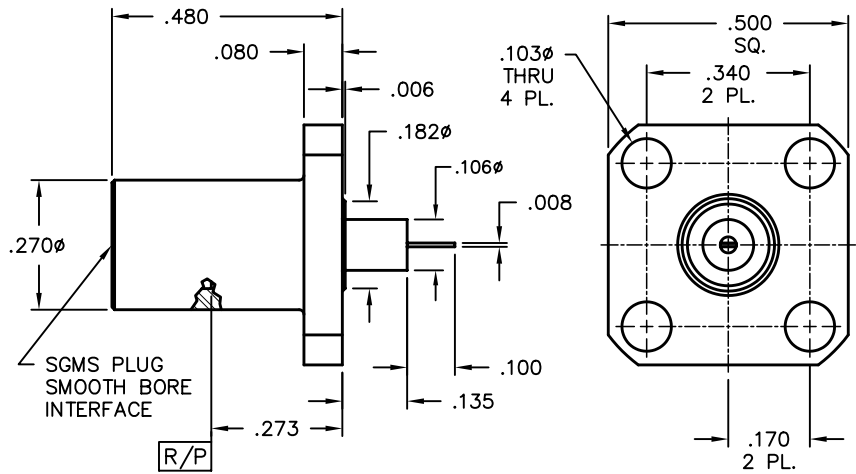

Plug 2 Hole Flange Mount Tab Terminal

Catalog Number	A
P001-M35-01	

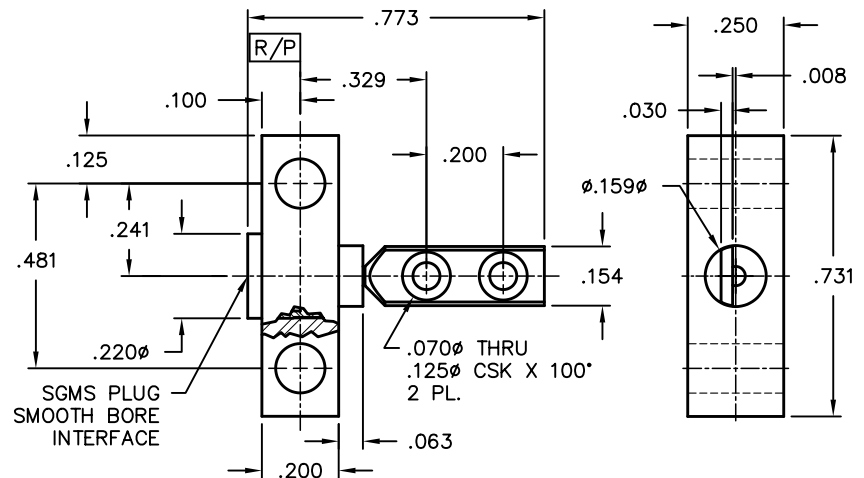

SGMS Thread-in Shrouds

Plug Limited Detent High Average Power Thread-in to Terminal

Catalog Number
6804-100-2

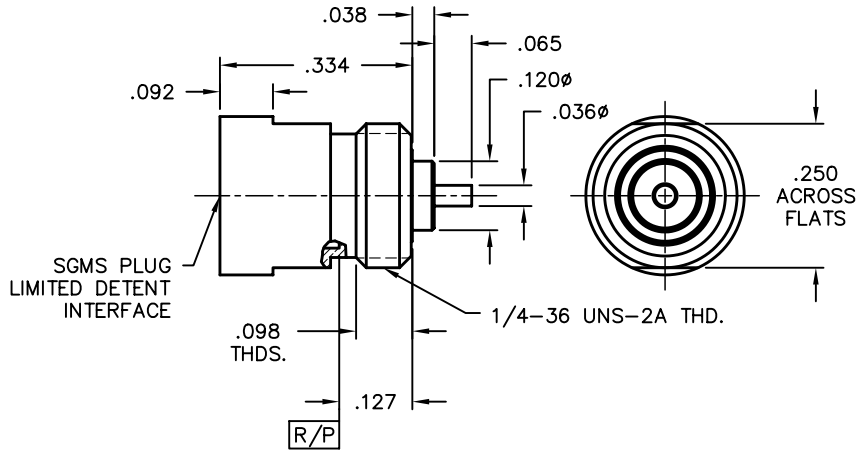

Plug Smooth Bore Thread-in with 0.018 C/C

Catalog Number
P003-L35-01

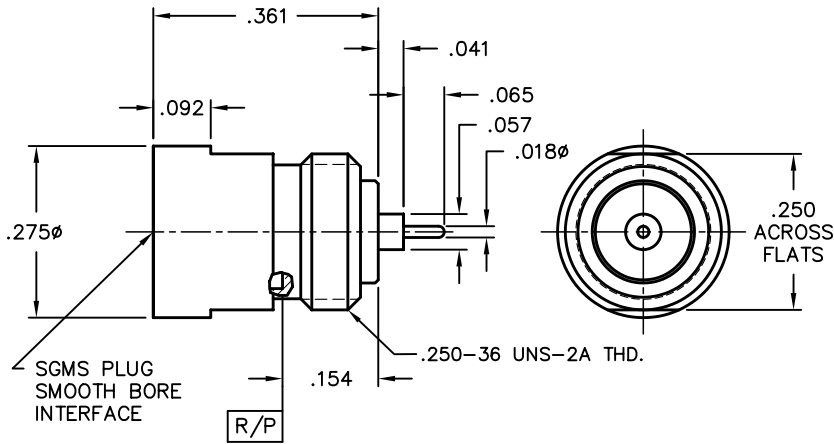

SGMS Multiposition Blocks

**Male Smooth Bore Catchers Mitt
4-Position SMT Board Mount**

Catalog Number

P032-L16-01

Mating Block:

P033-D14-01

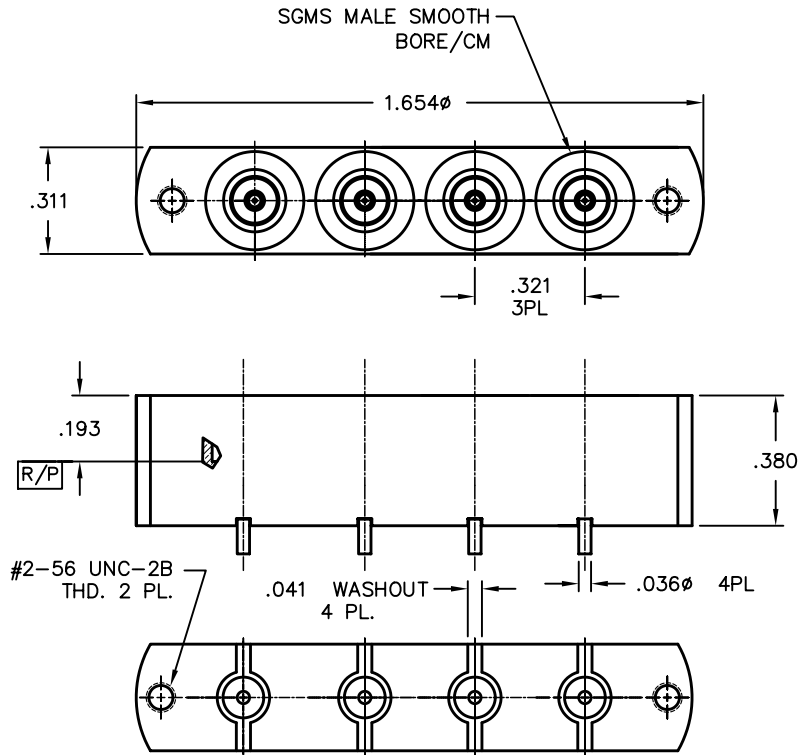
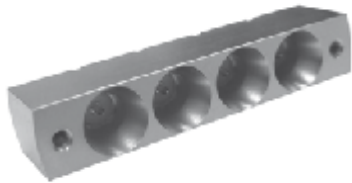

**Male Limited Detent 4-Position
to 0.086 Flex Cable**

Catalog Number

P033-D14-01

Mating Block:

P032-L16-01

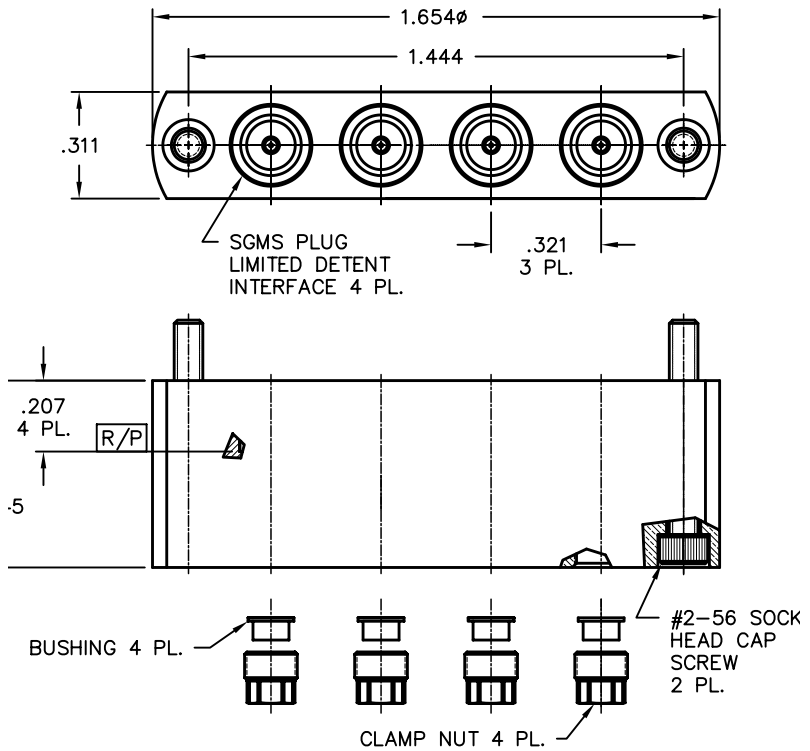

Adapters



Adapter Matrices

The chart listed below is designed to aid in locating the appropriate adapter by application. All adapters can be found on pages 107 through 131 in this catalog.

NOTE: The X in the part numbers below refers to a detent-tabbed item. Replace the X with a 3 for a Full Detent, a 4 for a Limited Detent, or a 5 for a Smooth Bore. Not all detents are available for all adapters. All part numbers in purple indicate parts made to order.

GPO/GPPO/G3PO/G4PO Adapters							
	GPO (M)	GPO (F)	GPPO (M)	GPPO (F)	G3PO (M)	G3PO (F)	G4PO (M)
1.85mm (M)	1AXM2-0509-01	1A1M2-0509-01	1BXM2-0509-01	1B1M2-0509-01	1RXM2-0503-01	1R1M2-0509-01	
1.85mm (F)	1AXM1-0509-01	1A1M1-0509-01	1BXM1-0509-01	1B1M1-0509-01	1RXM1-0503-01	1R1M1-0509-01	1SXM1-0503-01
2.4mm (M)	1AXC2-0509-01	1A1C2-0521-01	1BXC2-0503-01	1B1C2-0501-01	1RXC2-0503-01	1R1C2-0501-01	
2.4mm (F)	1AXC1-0503-01	1A1C1-0503-01	1BXC1-0503-01	1B1C1-0501-01	1RXC1-0503-01	1R1C1-0501-01	
2.92mm (M)	1AXD2-0503-01	1A1D1-0501-01	1BXD2-0503-01	1B1D2-0501-01	1RXD2-0503-01	1R1D2-0501-01	1SXD2-0503-01
2.92mm (F)	1AXD1-0503-01	1A1D1-0503-01	1BXD1-0503-01	1B1D1-0503-01	1RXD1-0503-01	1R1D1-0503-01	
SMA (M)	1A3F2-0503-01	1A1F2-0503-01	1BXF2-0503-01	1B1F2-0503-01	1RXF2-0503-01	1R1F2-0503-01	
SMA (F)	1AXF1-0503-01 1AXF1-0513-03 1AXF1-0513-05 1AXF1-0523-01	1A1F1-0503-01	1BXF1-0503-01	1B1F1-0503-01	1RXF1-0509-01	1R1F1-0503-01	
GPO (M)	A3AX-0539-01			1B1A3-0541-01			
GPO (F)	A1AX-0503-01	*A1A1-0001-XX					
GPPO (M)			BXBX-0523-01 BXBX-0523-02				
GPPO (F)				*B1B1-0001-XX			
G3PO (F)						*R1R1-0001-XX	

*XX refers to bullet lengths. GPO, GPPO and G3PO Blindmate interconnect bullets are available in different lengths. Please consult the factory for information on bullet lengths not found in this catalog.

GMS Adapters		SGMS Adapters		
	GMS (M)	GMS (F)	SGMS (F)	SGMS (M)
SMA (M)	00218-400-3	00218-200-3 00218-201-3	00218-201-3	
SMA (F)	00218-300-3 00218-301-3	00218-100-3 00218-101-3	00218-101-3	1F1P5-0503-01
SGMS (F)			1881-001-1	

GPO Within Series Adapters

GPO Female to GPO Male

Catalog Number	A
A1A3-0503-01	FD
A1A4-0503-01	LD
A1A5-0503-01	SB

VSWR (TYP)
1.20:1 to 18 GHz, 1.30:1 to 26.5 GHz

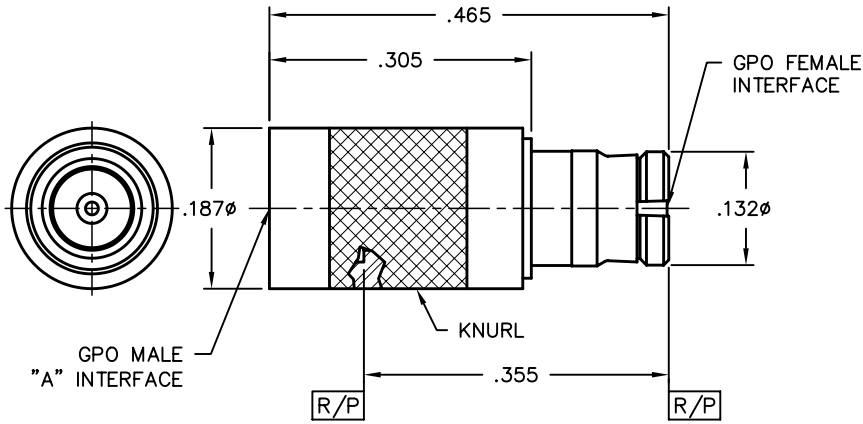

GPO Male CM to GPO Male FD Thread-in

Catalog Number
0119-632-3

VSWR (TYP)
1.15:1 to 18 GHz, 1.25:1 to 26.5 GHz

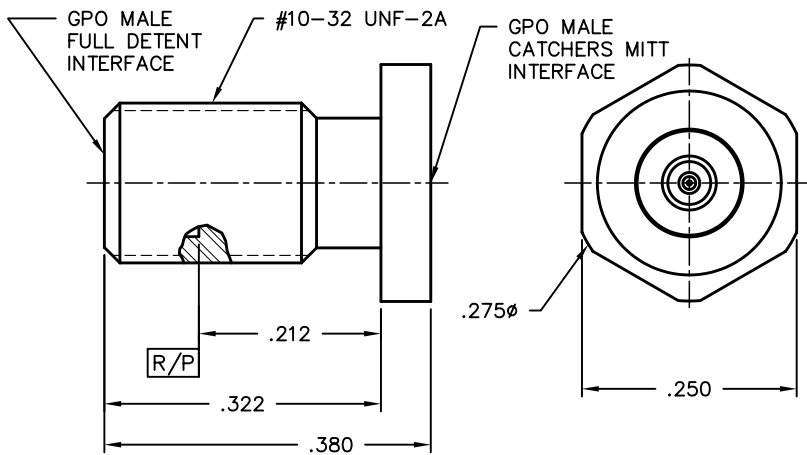

GPO Male to GPO Male Thread-in

Catalog Number	A-B
A3A6-0539-01	FD-CM
A3A3-0539-01	FD-FD

VSWR (TYP)
1.15:1 to 18 GHz, 1.25:1 to 26.5 GHz

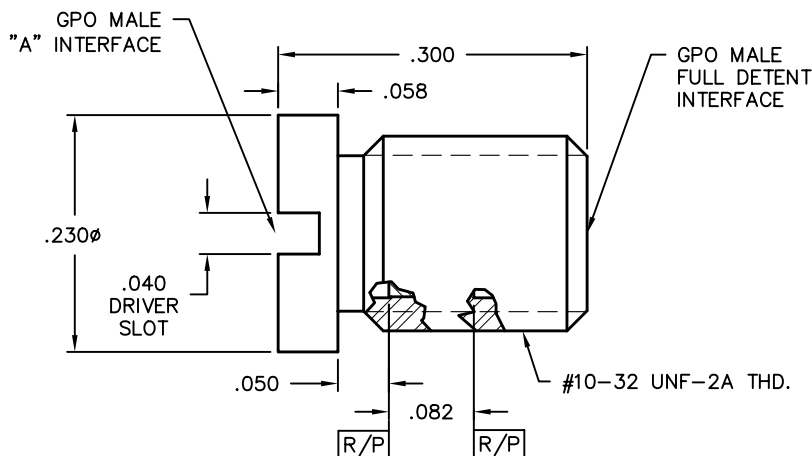

GPO Within Series Adapters

GPO Male Full Detent to GPO Male Full Detent Thread-in

Catalog Number
0119-579-3

VSWR (TYP)
1.25:1 to 18 GHz
1.35:1 to 26.5 GHz

Tools Recommended
A090-A99-01

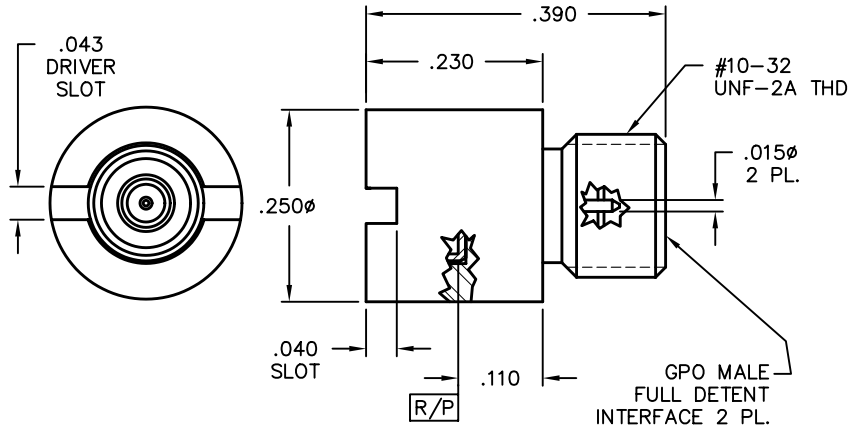

GPO Male FD to GPO Male FD Feed-thru

Catalog Number
0119-843-3

VSWR (TYP)
1.15:1 to 18 GHz, 1.30:1 to 26.5 GHz

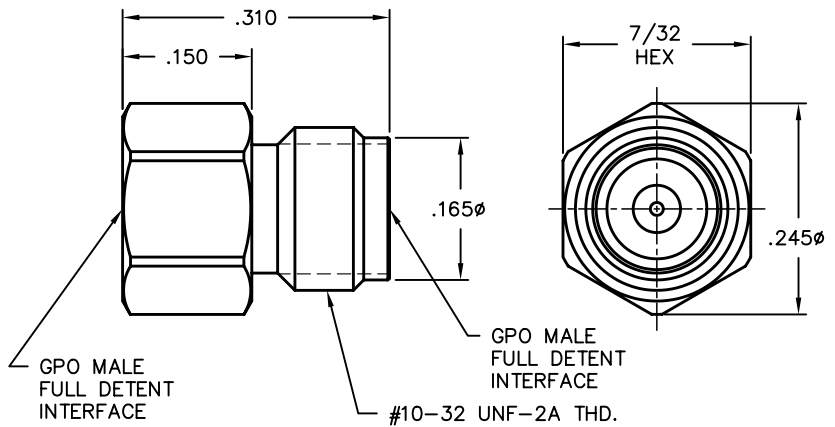

GPO Male FD to GPO Male FD Thread-in Hermetic Feed-thru

Catalog Number
0119-783-1

VSWR (TYP)
1.15:1 to 18 GHz, 1.30:1 to 26.5 GHz

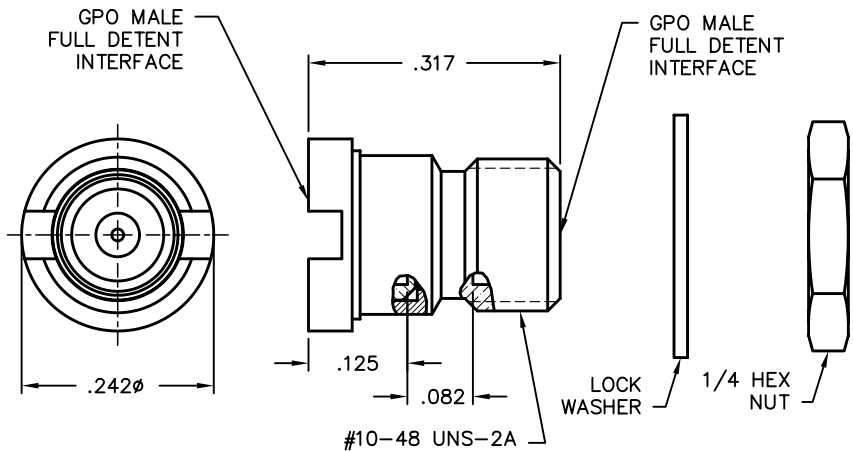

GPO Within Series Adapters

GPO Male FD to GPO Male CM Thread-in

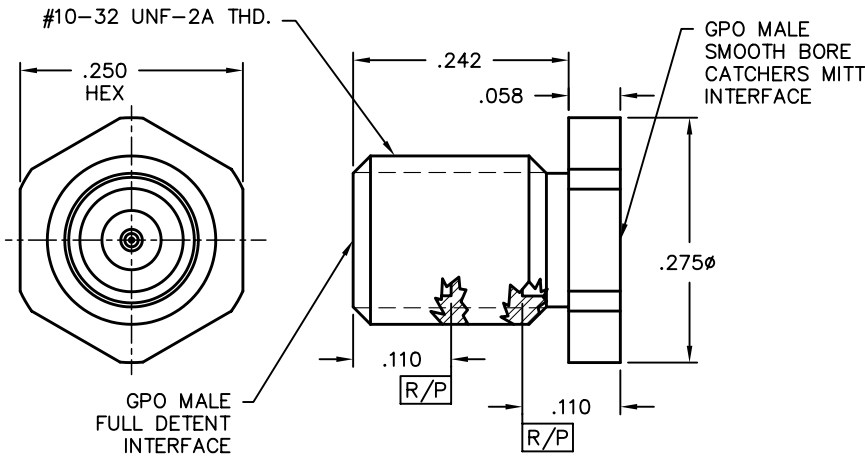

Catalog Number
0119-502-3

VSWR (TYP)
1.10:1 to 18 GHz, 1.20:1 to 26.5 GHz



GPO Between Series Adapters

GPO Male to SMA Jack

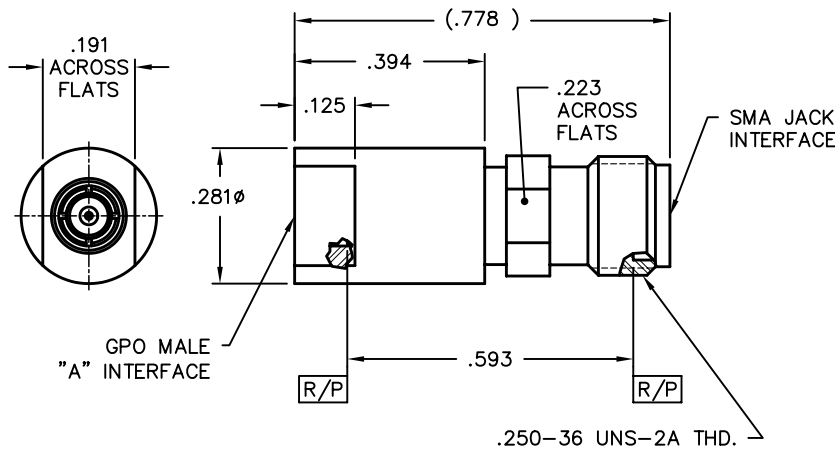

Catalog Number **A**

1A3F1-0503-01	FD
1A4F1-0503-01	LD
1A5F1-0503-01	SB

VSWR (TYP)
1.10:1 to 18 GHz, 1.35:1 to 26.5 GHz



GPO Between Series Adapters

GPO Male to SMA Jack

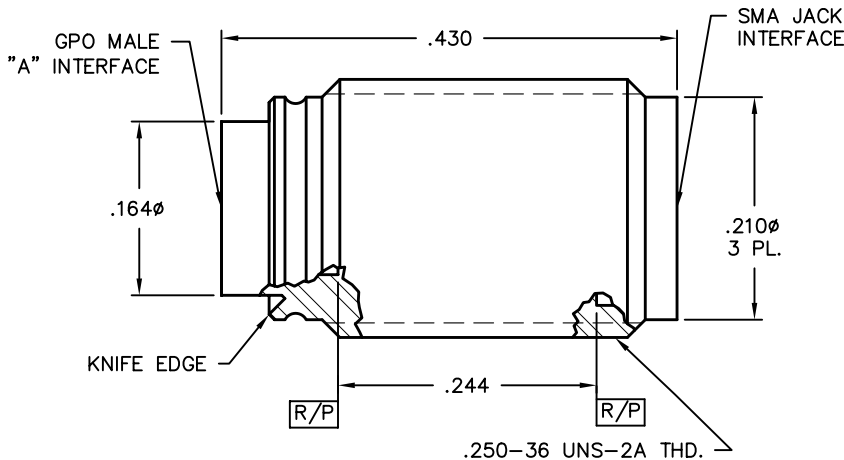

Catalog Number **A**

1A3F1-0523-01	FD
1A4F1-0523-01	LD
1A5F1-0523-01	SB

VSWR (TYP)
1.20:1 to 18 GHz, 1.30:1 to 26.5 GHz



GPO Between Series Adapters

GPO Male to SMA Jack Thread-in

Catalog Number	A
1A3F1-0523-02	FD
1A4F1-0523-02	LD
VSWR (TYP)	
1.10:1 to 18 GHz, 1.20:1 to 26.5 GHz	

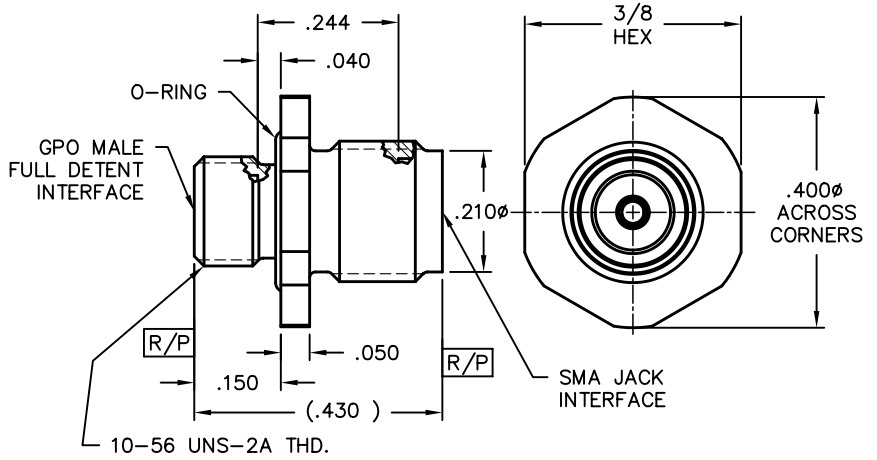

GPO Male to SMA Jack Thread-in

Catalog Number	A
1A3F1-0523-05	FD
1A5F1-0523-05	SB
VSWR (TYP)	
1.10:1 to 18 GHz, 1.20:1 to 26.5 GHz	

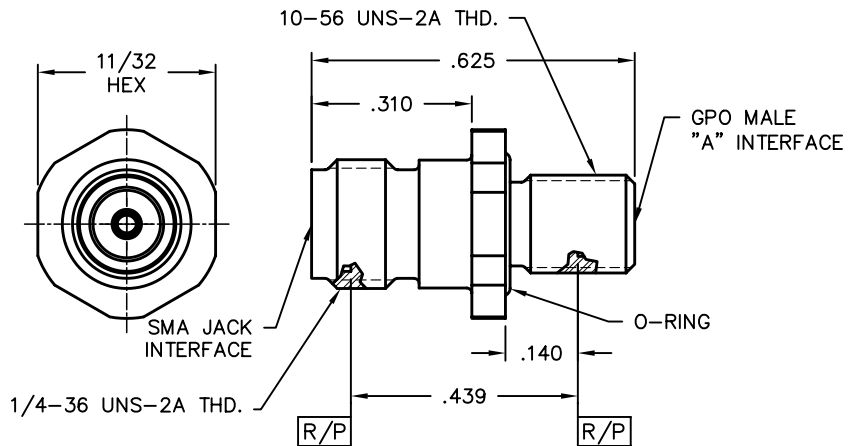

GPO Male to SMA Jack 2-Hole Flange Mount

Catalog Number	A
1A3F1-0513-03	FD
1A4F1-0513-03	LD
1A5F1-0513-03	SB
VSWR (TYP)	
1.10:1 to 18 GHz, 1.20:1 to 26.5 GHz	

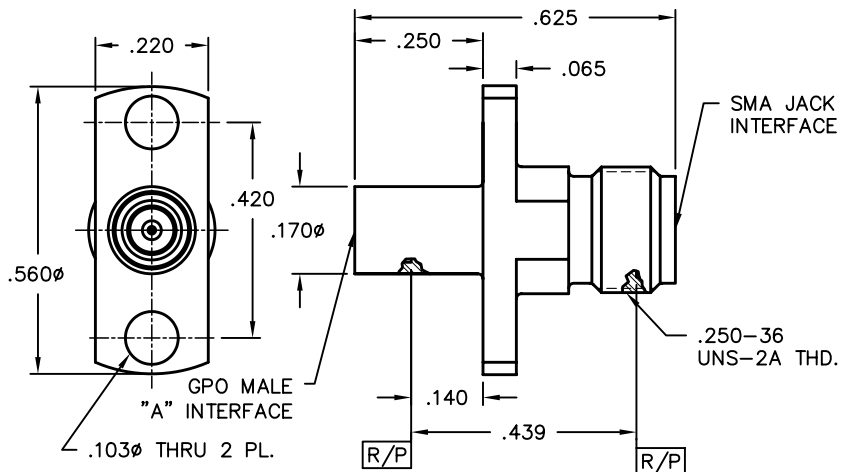

GPO Between Series Adapters

GPO Male to SMA Jack 2-Hole Flange Mount

Catalog Number	A
1A3F1-0513-05	FD
1A4F1-0513-05	LD
1A5F1-0513-05	SB
VSWR (TYP)	
1.10:1 to 18 GHz, 1.20:1 to 26.5 GHz	

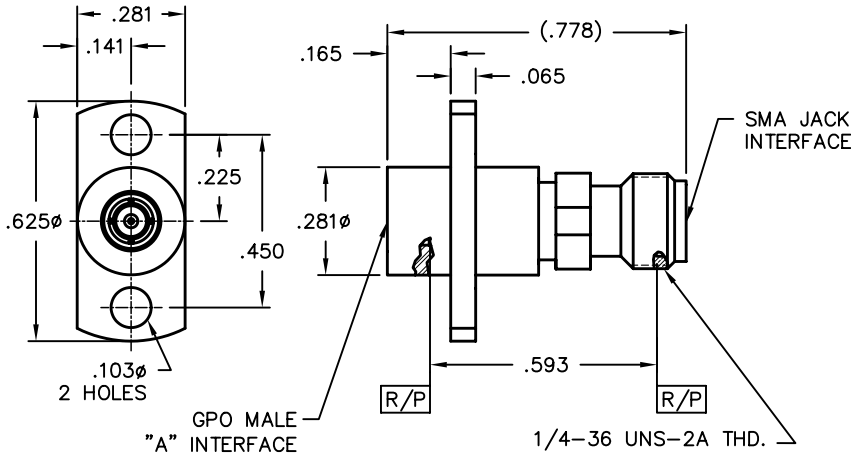

GPO Male FD to SMA Jack 2-Hole w/O-Ring

Catalog Number	
00219-125-3	
VSWR (TYP)	
1.10:1 to 18 GHz, 1.20:1 to 23 GHz	

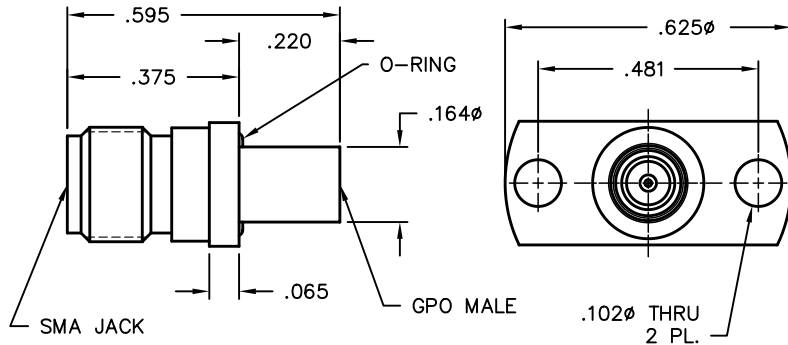

GPO Male LD to SMA Jack 2-Hole Flange Mount

Catalog Number	
00219-128-3	
VSWR (TYP)	
1.10:1 to 18 GHz, 1.20:1 to 26.5 GHz	

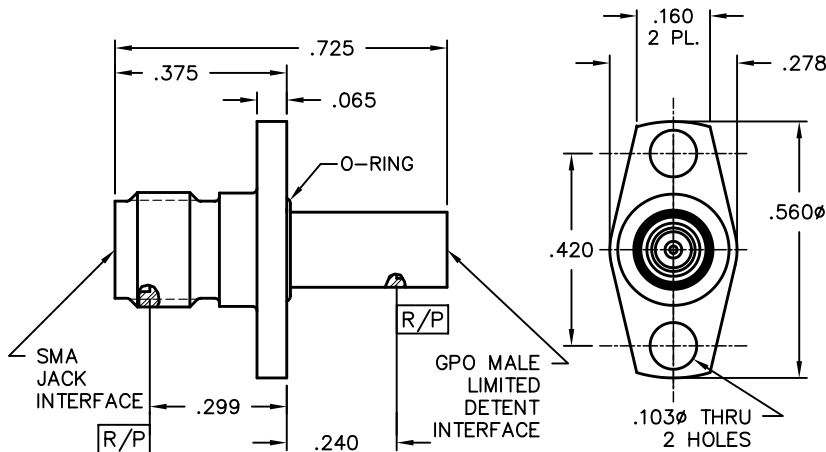

GPO Between Series Adapters

GPO Male SB CM to SMA Jack 2-Hole Flange Mount

Catalog Number
1A6F1-0513-02

VSWR (TYP)
1.10:1 to 18 GHz, 1.20:1 to 26.5 GHz

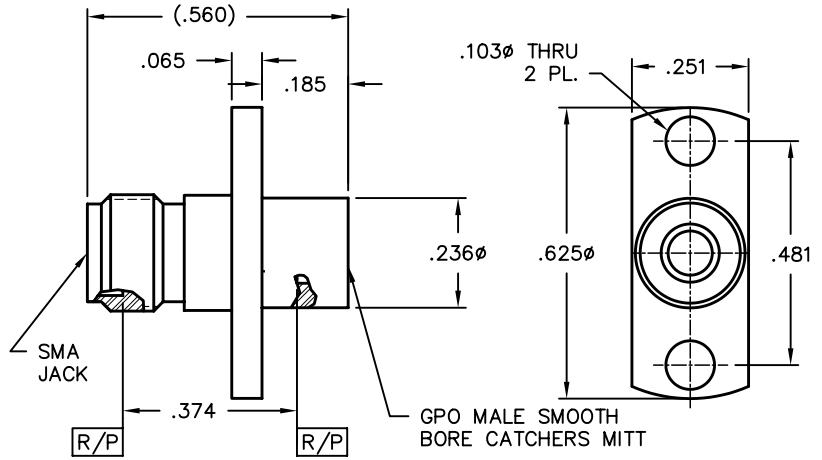

GPO Male FD to SMA Jack 4-Hole Flange Mount

Catalog Number
00219-142-3-V10

VSWR (TYP)
1.10:1 to 18 GHz, 1.20:1 to 26.5 GHz

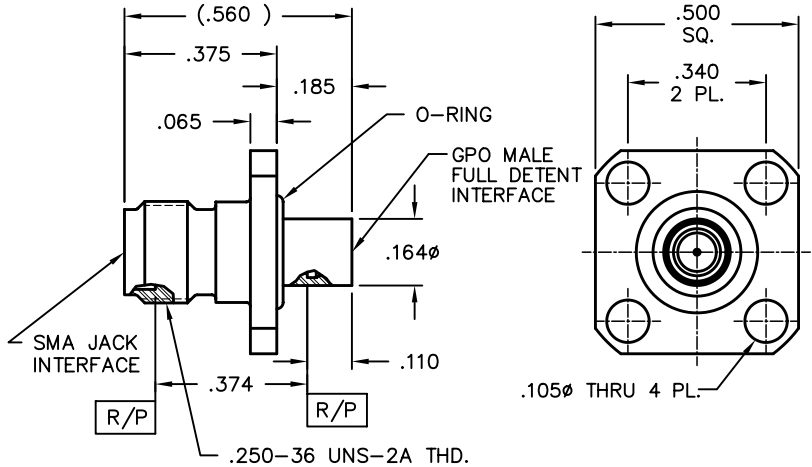

GPO Male to SMA Jack 4-Hole Flange Mount

Catalog Number **A**

1A3F1-0513-02 FD

1A5F1-0513-02 SB

VSWR (TYP)
1.10:1 to 18 GHz, 1.20:1 to 26.5 GHz

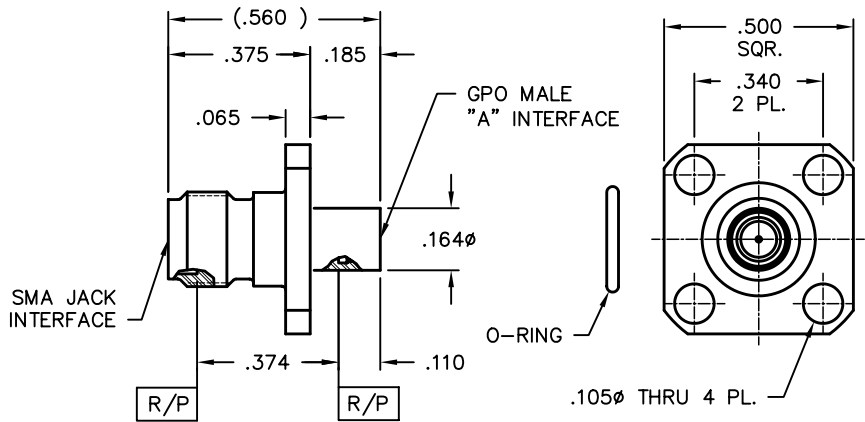

GPO Between Series Adapters

GPO Male FD to SMA Jack 4-Hole Flange Mount

Catalog Number

1A3F1-0513-04

VSWR (TYP)

1.10:1 to 18 GHz, 1.20:1 to 26.5 GHz

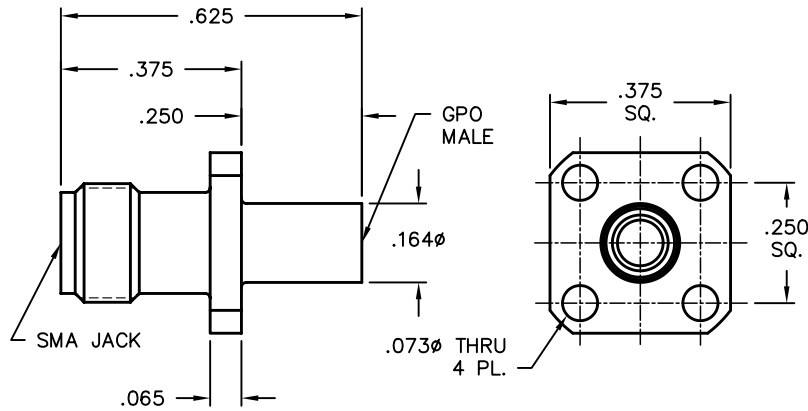

GPO Female to SMA Jack

Catalog Number

1A1F1-0503-01

VSWR (TYP)

1.15:1 to 15 GHz, 1.45:1 to 26.5 GHz

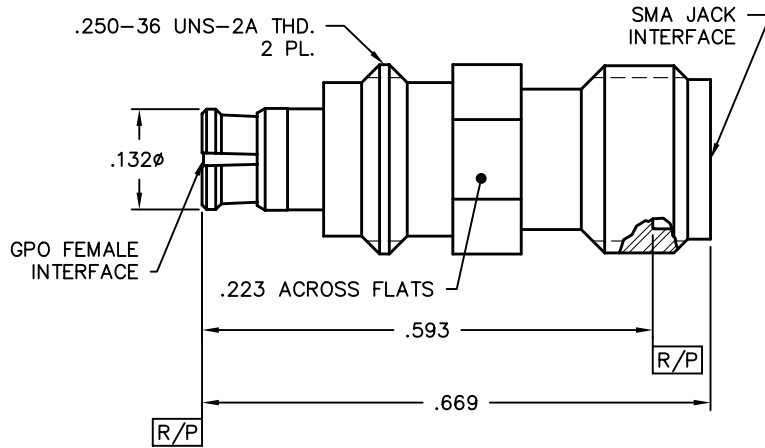

GPO Female to SMA Jack w/EMI Gasket

Catalog Number

00219-106-3

VSWR (TYP)

1.15:1 to 18 GHz, 1.25:1 to 26.5 GHz

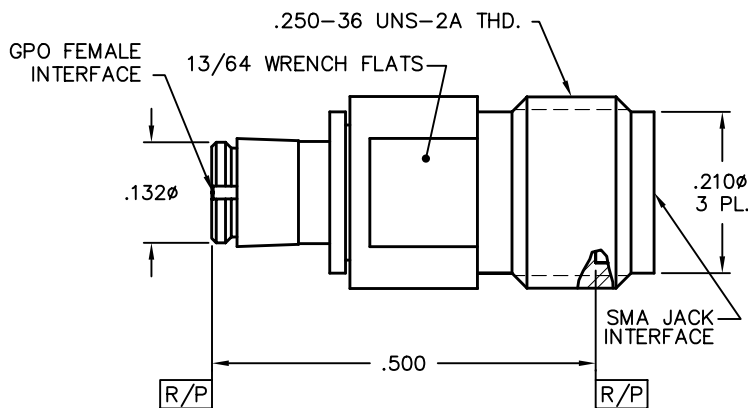

GPO Between Series Adapters

GPO Male to SMA Plug

Catalog Number	A
1A3F2-0503-01	FD
1A4F2-0503-01	LD
1A5F2-0503-01	SB
VSWR (TYP)	
1.15:1 to 18 GHz, 1.25:1 to 26.5 GHz	

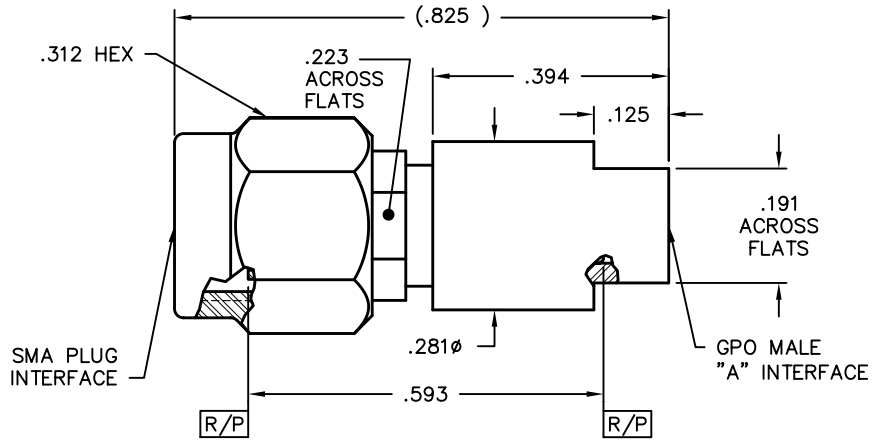

GPO Female to SMA Plug

Catalog Number	
1A1F2-0503-01	
VSWR (TYP)	
1.15:1 to 18.GHz, 1.25:1 to 26.5 GHz	

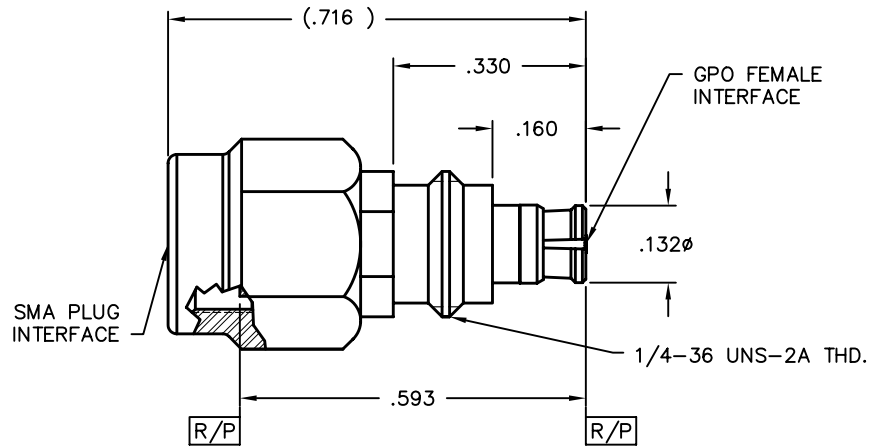

GPO Female to 2.4mm Plug

Catalog Number	
1A1C2-0521-01	
VSWR (TYP)	
1.10:1 to 18 GHz, 1.20:1 to 26.5 GHz	

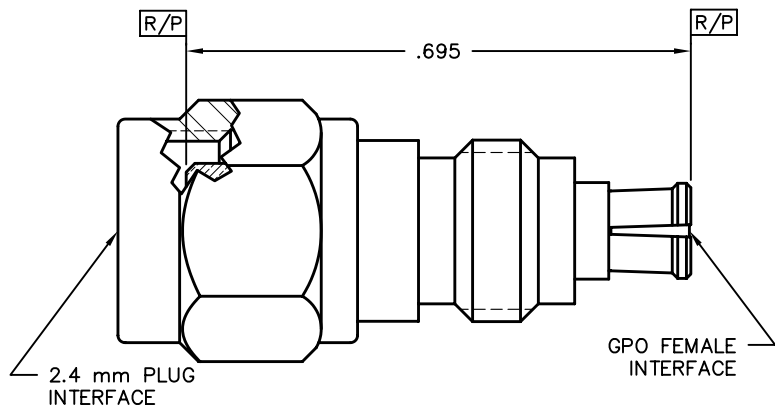

GPO Between Series Adapters

GPO Male FD to 2.4mm Jack

Catalog Number

1A3C1-0503-01

VSWR (TYP)

1.20:1 to 26.5 GHz

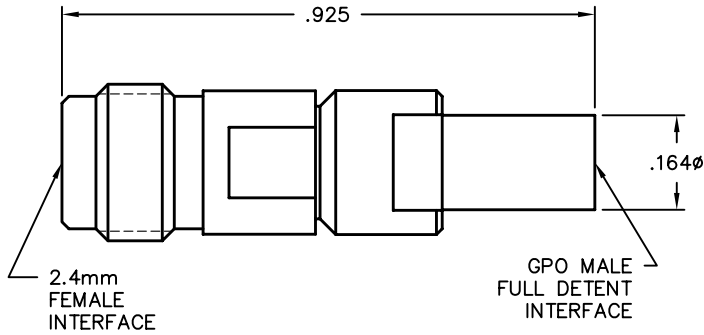

GPO Female to 2.92mm Jack

Catalog Number

1A1D1-0501-01

VSWR (TYP)

1.20 to 26.5 GHz

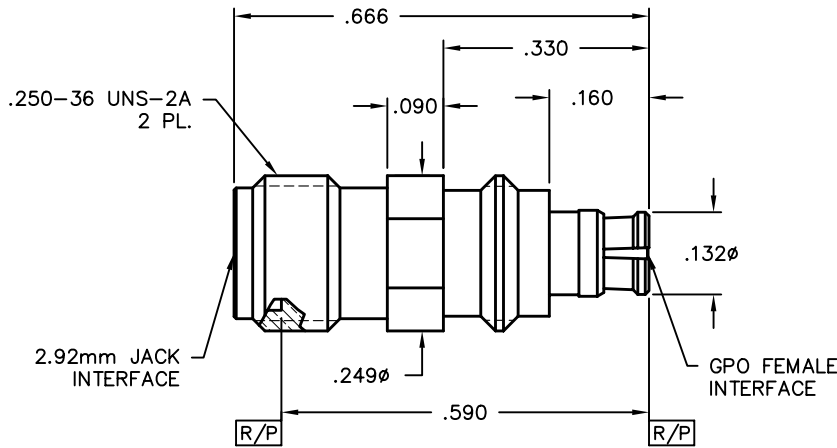

GPO Female to 2.92mm Plug

Catalog Number

1A1D2-0501-01

VSWR (TYP)

1.10:1 to 18 GHz, 1.25:1 to 26.5 GHz

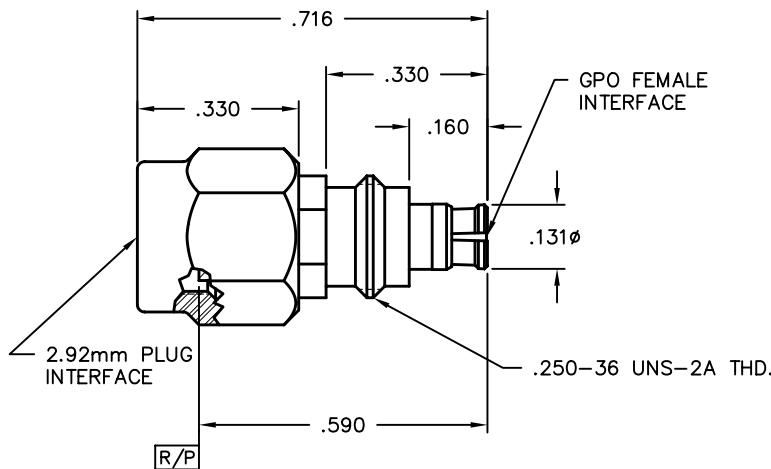

GPO Between Series Adapters

GPO Male to 2.92mm Jack

Catalog Number	A
1A3D1-0503-01	FD
1A4D1-0503-01	LD
1A5D1-0503-01	SB
VSWR (TYP)	
1.20:1 to 26.5 GHz	

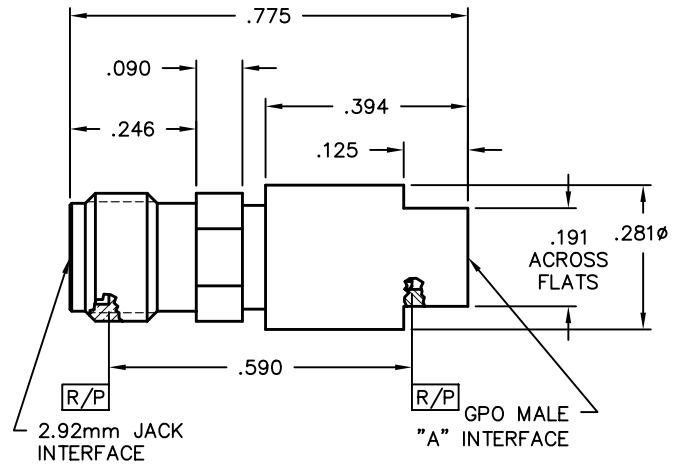

GPO Male to 2.92mm Jack 2-Hole Flange Mount

Catalog Number	A
1A3D1-0513-01	FD
1A4D1-0513-01	LD
1A5D1-0513-01	SB
VSWR (TYP)	
1.20:1 to 26.5 GHz	

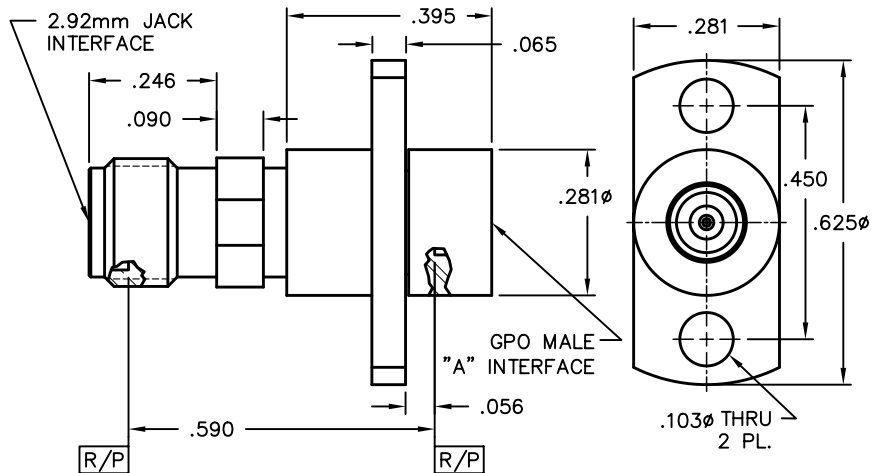

GPO Female to 3.5mm Plug

Catalog Number	
03501-210-1	
VSWR (TYP)	
1.15:1 to 18 GHz, 1.30:1 to 26.5 GHz	

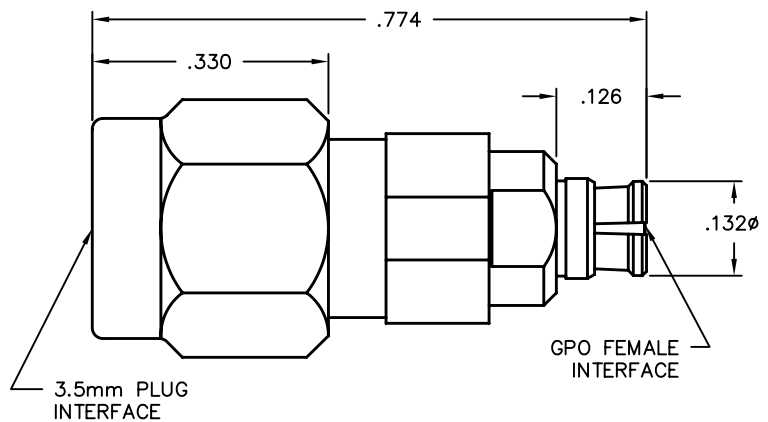

GPO Between Series Adapters

GPO Male FD to SSMA Jack Thread-in Bulkhead

Catalog Number

1A3G1-0533-01

VSWR (TYP)

1.20:1 to 18 GHz, 1.35:1 to 26.5 GHz

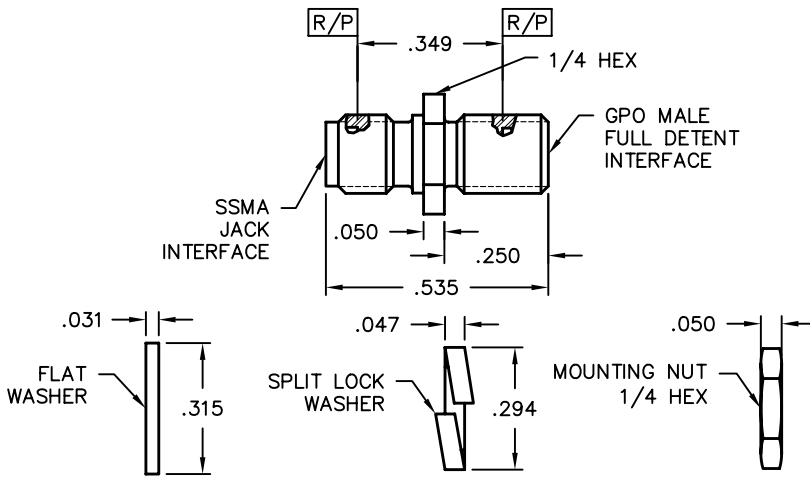

GPO Male FD to SSMA Jack Thread-in

Catalog Number

00119-117-3

VSWR (TYP)

1.20:1 to 18 GHz, 1.35:1 to 26.5 GHz

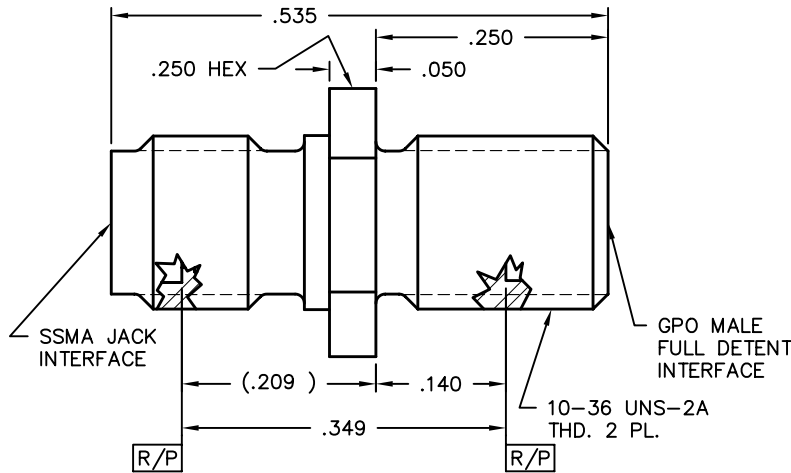

GPO Male FD 4-Hole Flange Mount to SSMA Jack R/A

Catalog Number

00119-011-3

VSWR (TYP)

1.25:1 to 18 GHz

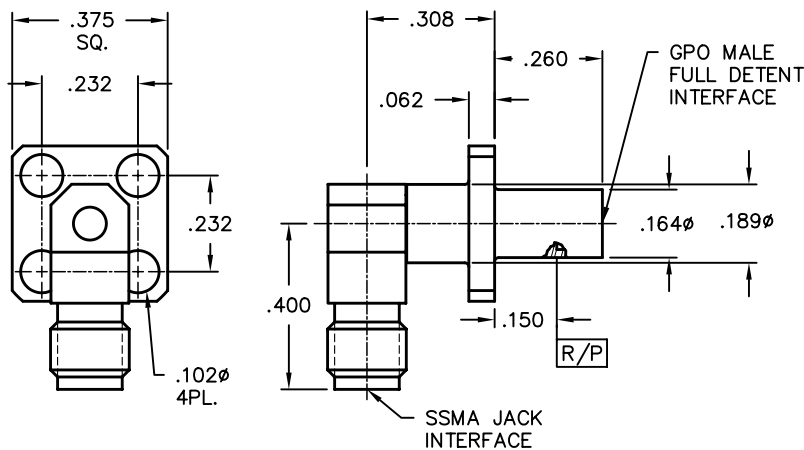

GPO Between Series Adapters

GPO Male FD to TNC Jack

Catalog Number

00419-302-3

VSWR (TYP)

1.04+.02F(GHz):1 to 18 GHz

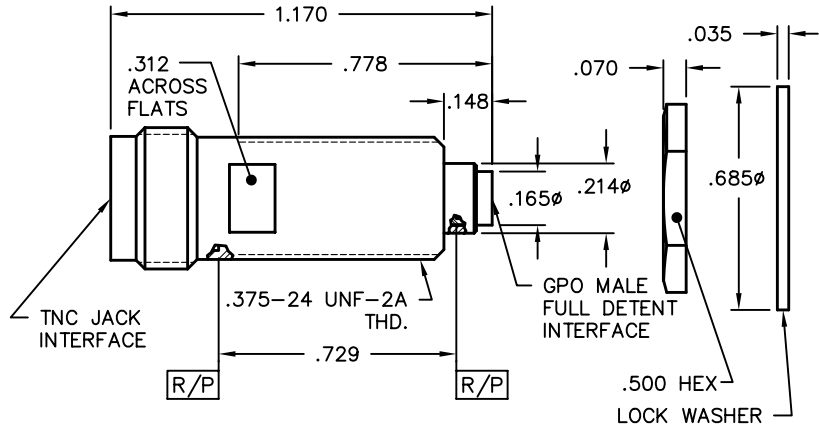

GPO Male FD to TNC Jack Bulkhead

Catalog Number

00419-303-3

VSWR (TYP)

1.04+.02F(GHz):1 to 18 GHz

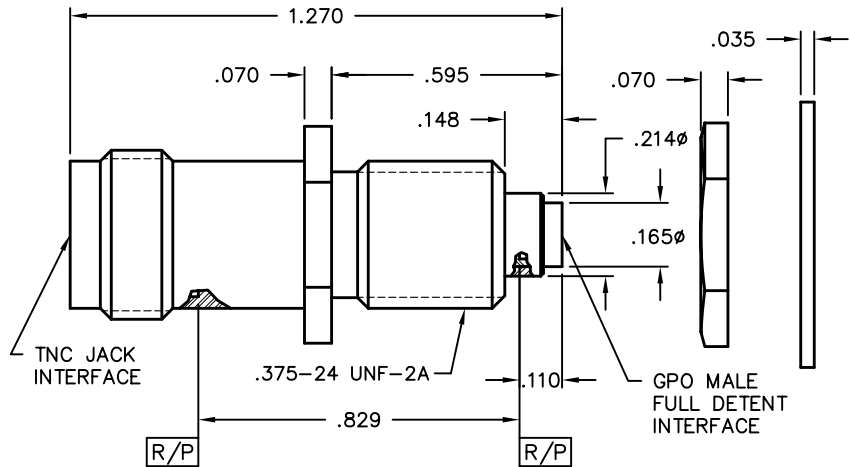

GPPO Within Series Adapters

GPPO Male to GPPO Male Thread-in

Catalog Number A-B

B3B3-0523-01 FD-FD

B5B3-0523-01 SB-FD

VSWR (TYP)

1.20:1 to 26.5 GHz, 1.30:1 to 40 GHz

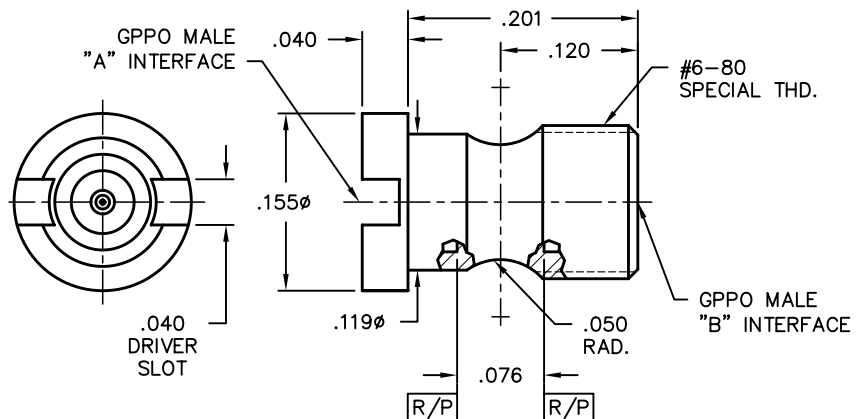

GPPO Within Series Adapters

GPPO Male to GPPO Male Thread-in

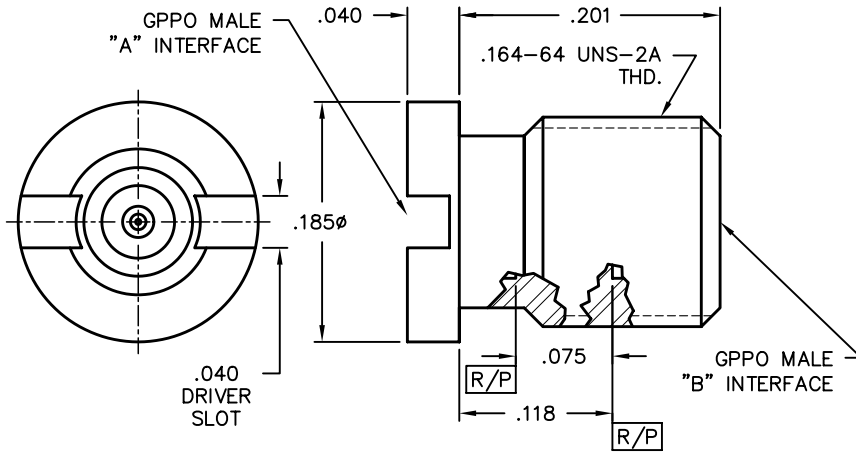

Catalog Number	A-B
B3B3-0523-02	FD-FD
B3B5-0523-02	FD-SB
B5B3-0523-02	SB-FD
B5B5-0523-02	SB-SB

VSWR (TYP)
1.20:1 to 26.5 GHz, 1.30:1 to 40 GHz



GPPO Between Series Adapters

GPPO Female Snap-in Bulkhead Mount to GPO Male FD

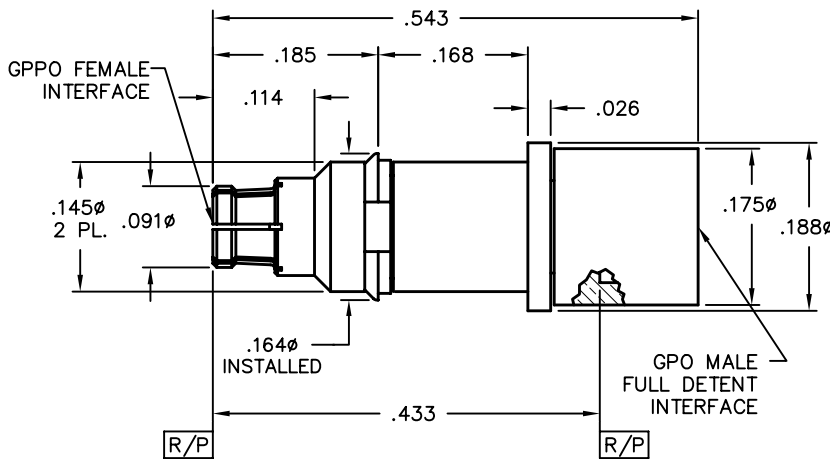

Catalog Number
1B1A3-0541-01

VSWR (TYP)
1.20:1 to 26.5 GHz, 1.30:1 to 40 GHz



GPPO Female to SMA Jack

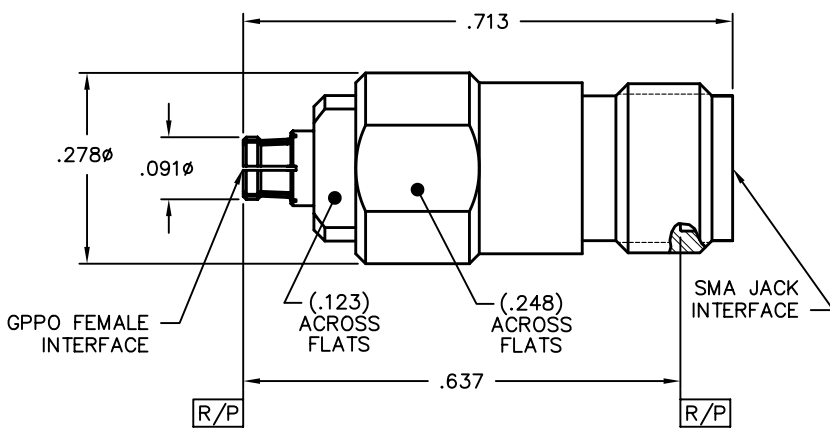

Catalog Number
1B1F1-0503-01

VSWR (TYP)
1.15:1 to 12 GHz, 1.30:1 to 26.5 GHz



GPPO Between Series Adapters

GPPO Female to SMA Plug

Catalog Number
1B1F2-0503-01

VSWR (TYP)
1.20:1 to 26.5 GHz

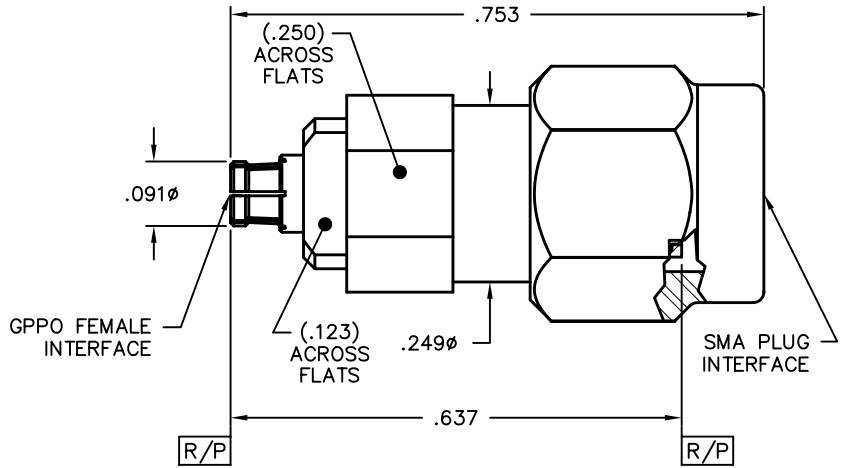

GPPO Male to SMA Jack

Catalog Number A

1B3F1-0503-01 FD

1B5F1-0503-01 SB

VSWR (TYP)
1.10:1 to 12 GHz, 1.20:1 to 26.5 GHz

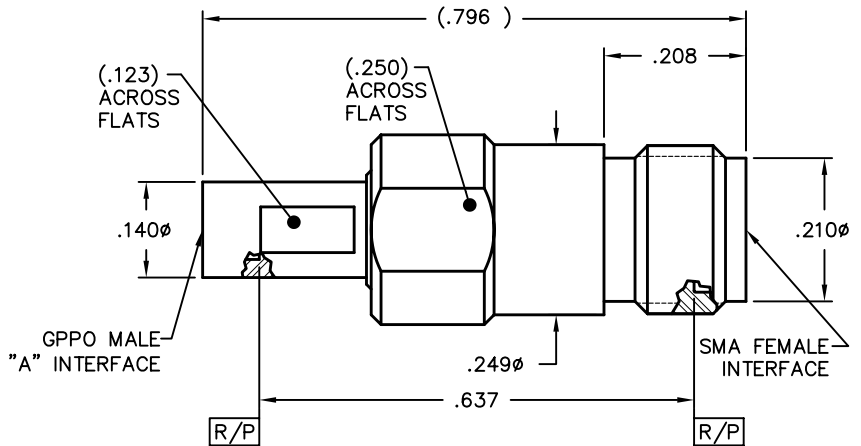

GPPO Male to SMA Plug

Catalog Number A

1B3F2-0503-01 FD

1B5F2-0503-01 SB

VSWR (TYP)
1.15:1 to 18 GHz, 1.25:1 to 26.5 GHz.

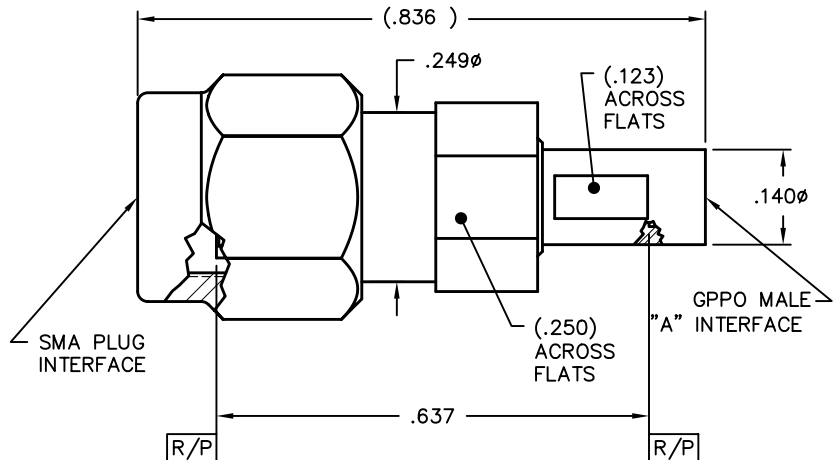

GPPO Between Series Adapters

GPPO Female to 2.4mm Jack

Catalog Number

1B1C1-0501-01

VSWR (TYP)

1.10:1 to 18 GHz, 1.20:1 to 40 GHz

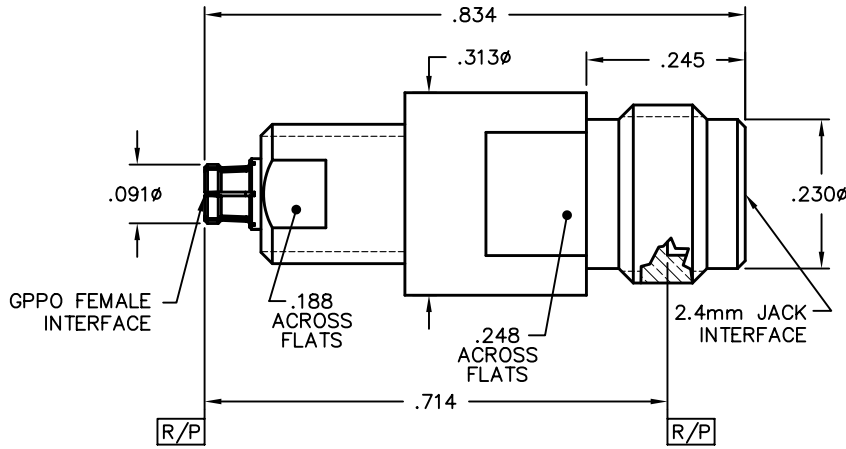

GPPO Female to 2.4mm Plug

Catalog Number

1B1C2-0501-01

VSWR (TYP)

1.20:1 to 26.5 GHz, 1.30:1 to 40 GHz

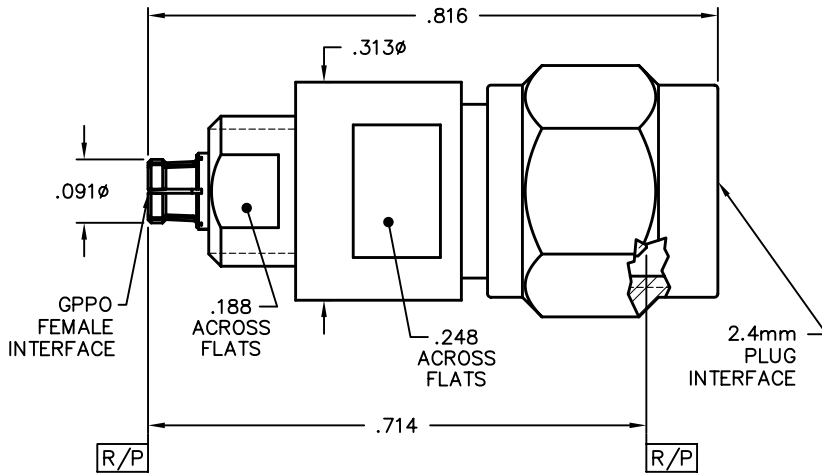

GPPO Male to 2.4mm Plug

Catalog Number A

1B3C2-0503-01 FD

1B5C2-0503-01 SB

VSWR (TYP)

1.20:1 to 26.5 GHz, 1.30:1 to 40 GHz

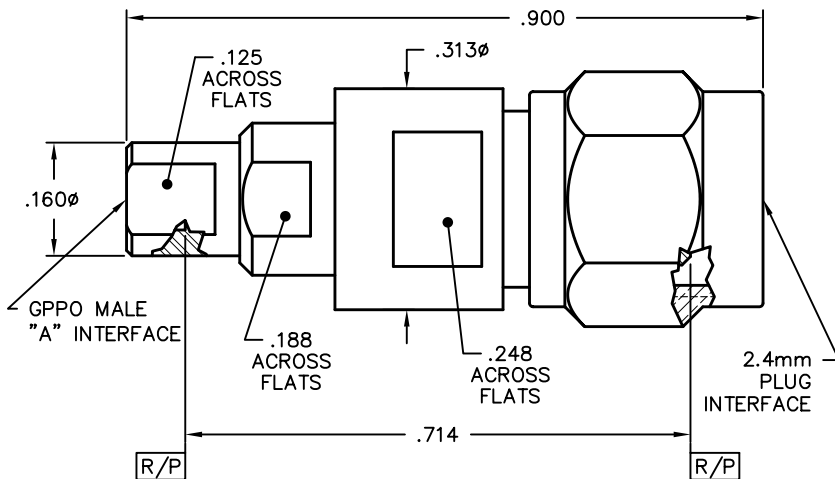

GPPO Between Series Adapters

GPPO Male to 2.4mm Jack

Catalog Number A
 1B3C1-0503-01 FD
 1B5C1-0503-01 SB
VSWR (TYP)
 1.20:1 to 26.5 GHz, 1.30:1 to 40 GHz

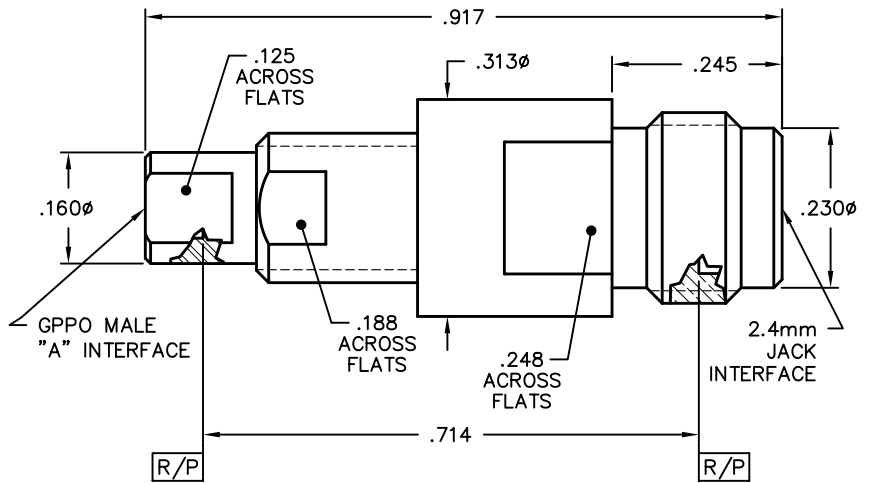

GPPO Female to 1.85mm Jack

Catalog Number
 1B1M1-0509-01
VSWR (TYP)
 1.20:1 to 26.5 GHz, 1.35:1 to 50 GHz

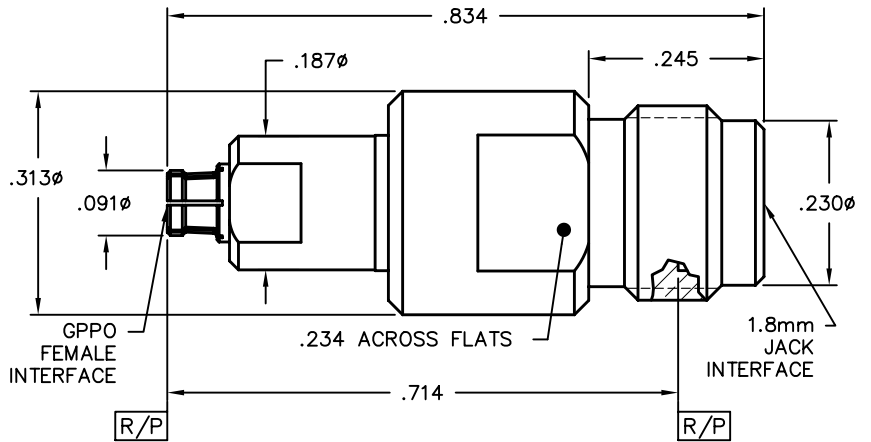

GPPO Female to 1.85mm Plug

Catalog Number
 1B1M2-0509-01
VSWR (TYP)
 1.20:1 to 26.5 GHz, 1.40:1 to 50 GHz

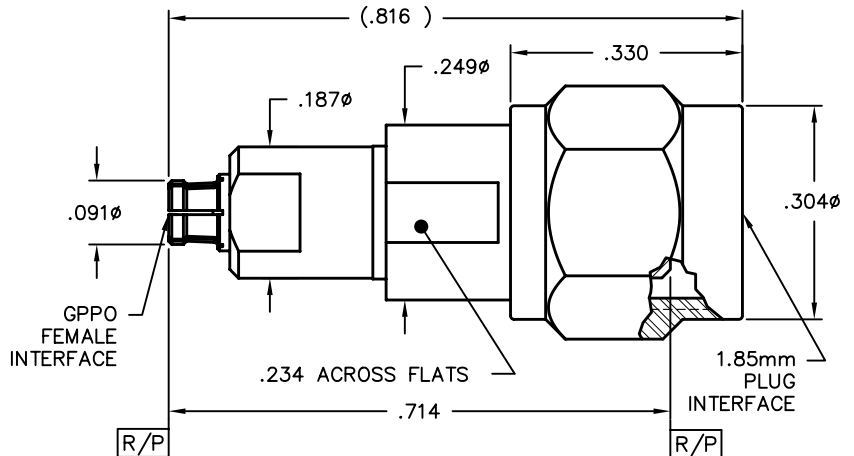

GPPO Between Series Adapters

GPPO Male to 1.85mm Jack

Catalog Number	A
1B3M1-0509-01	FD
1B5M1-0509-01	SB
VSWR (TYP)	
1.20:1 to 26.5 GHz, 1.40:1 to 50 GHz	

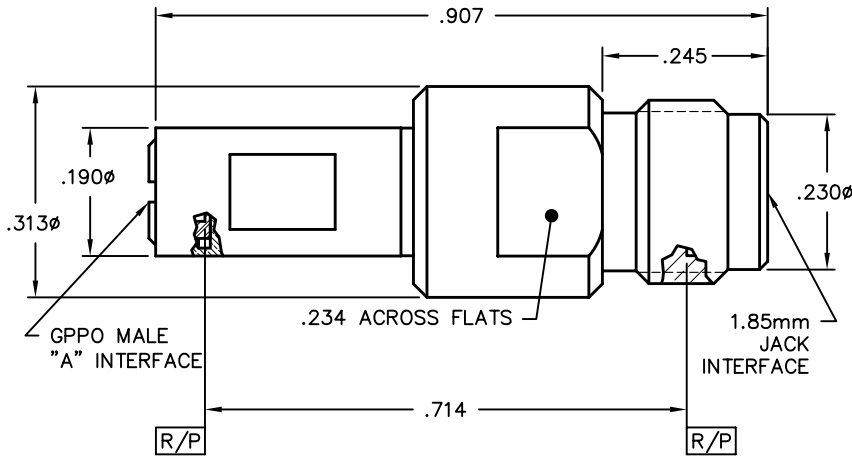

GPPO Male to 1.85mm Plug

Catalog Number	A
1B3M2-0509-01	FD
1B5M2-0509-01	SB
VSWR (TYP)	
1.20:1 to 26.5 GHz, 1.40:1 to 50 GHz	

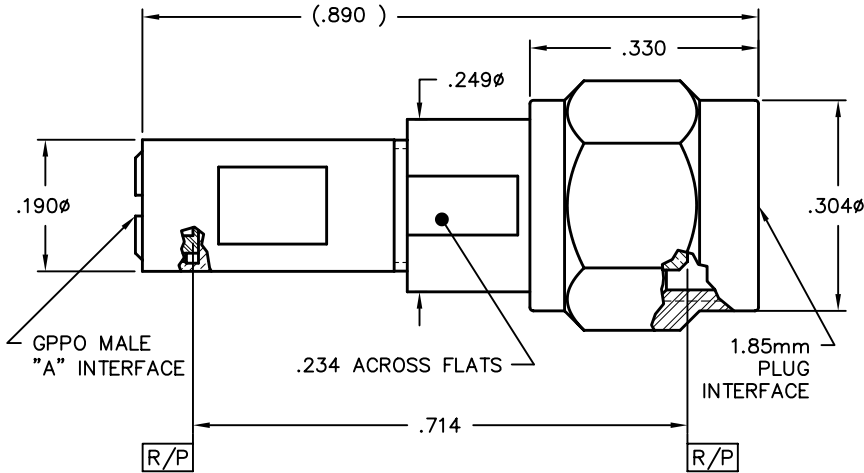

G3PO Adapters

G3PO Male to 1.85mm Jack

Catalog Number	A
1R3M1-0509-01	FD
1R5M1-0509-01	SB
VSWR (TYP)	
1.20:1 to 26.5 GHz, 1.30:1 to 65 GHz	

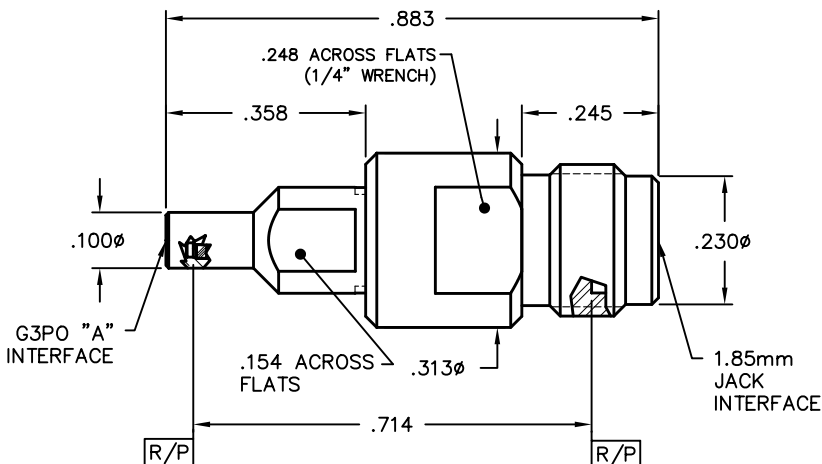

G3PO Adapters

G3PO Male to SMA Jack

Catalog Number A

1R3F1-0509-01 FD

1R5F1-0509-01 SB

VSWR (TYP)

1.20:1 to 18 GHz, 1.30:1 to 26 GHz

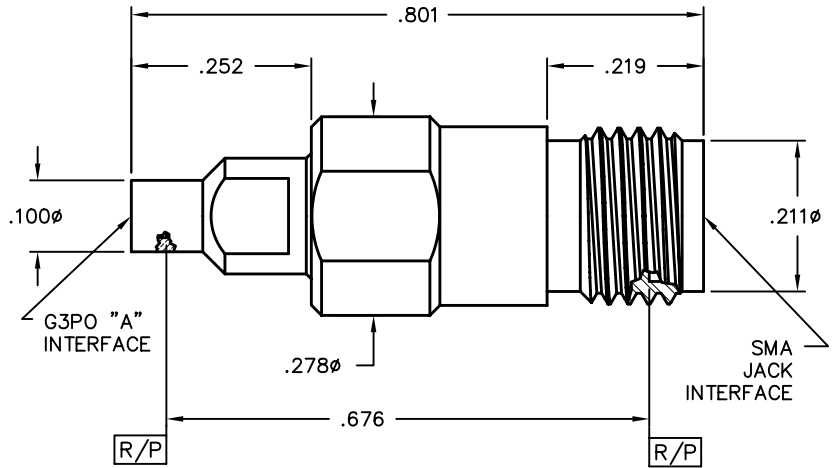

G3PO Female to 1.85mm Jack Adapter

Catalog Number

1R1M1-0509-01

VSWR (TYP)

1.15:1 to 26.5 GHz, 1.35:1 to 40 GHz

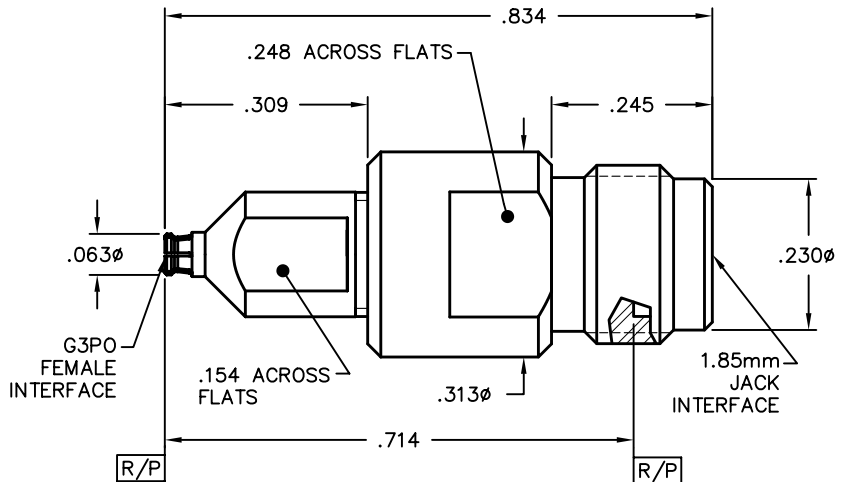

G3PO Male to 1.85mm Plug Adapter

Catalog Number A

1R3M2-0503-01 FD

1R5M2-0503-01 SB

VSWR (TYP)

1.15:1 to 26.5 GHz, 1.35:1 to 40 GHz

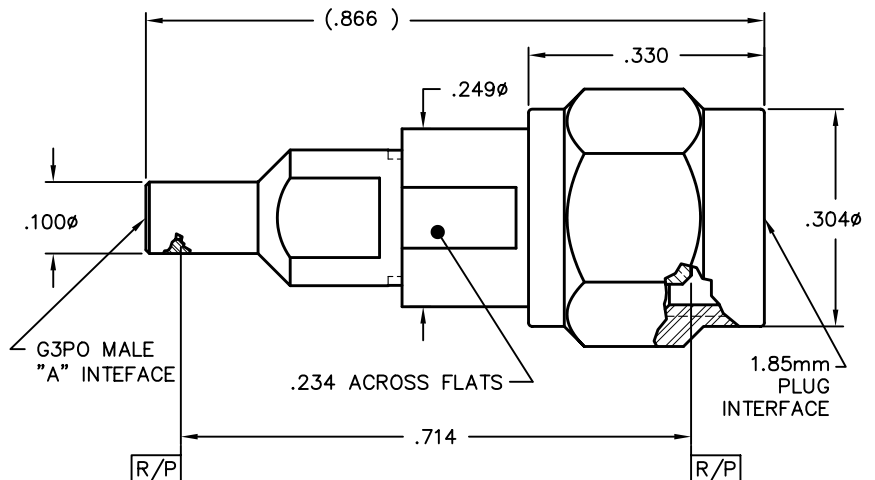

G3PO Adapters

G3PO Male to 2.9mm Jack Adapter

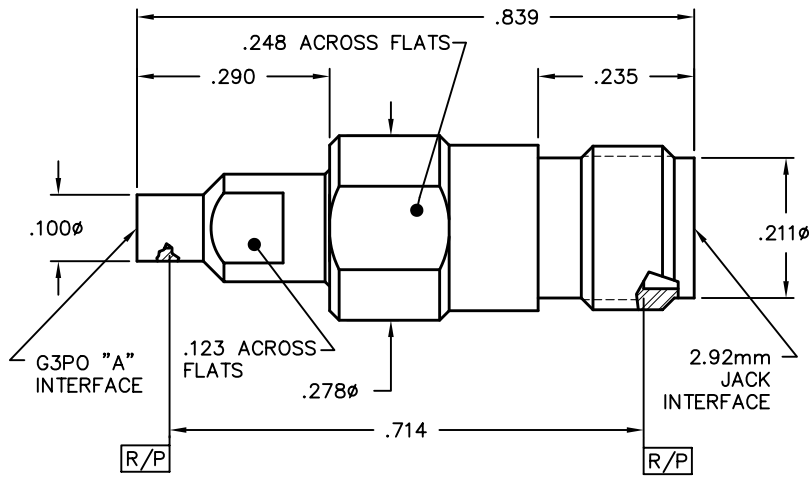

Catalog Number A

1R3D1-0503-01 FD

1R5D1-0503-01 SB

VSWR (TYP)

1.15:1 TO 26.5 GHz, 1.35:1 TO 40 GHz

G4PO Adapters

G4PO Male to 2.92mm Plug Adapter

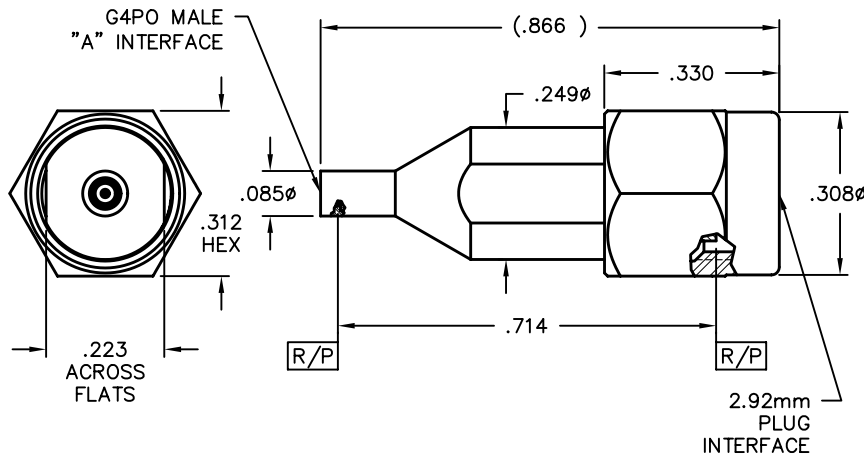

Catalog Number A

1S3D2-0503-01 FD

1S5D2-0503-01 SB

VSWR (TYP)

1.15:1 to 26.5 GHz, 1.35:1 to 40 GHz



G4PO Male to 1.85mm Jack Adapter

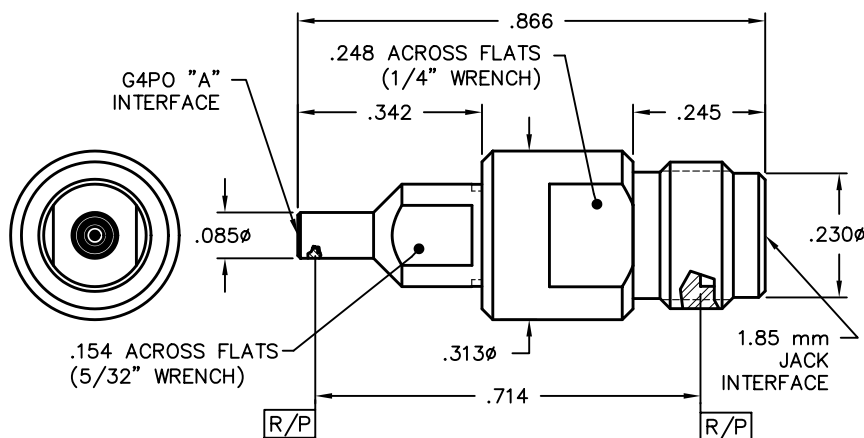

Catalog Number A

1S3M1-0503-01 FD

1S5M1-0503-01 SB

VSWR (TYP)

1.15:1 TO 26.5 GHz, 1.35:1 TO 40 GHz



GMS Adapters

GMS Jack to SMA Jack

Catalog Number

00218-103-3

VSWR (TYP)

1.20:1 to 18 GHz, 1.30:1 to 23 GHz

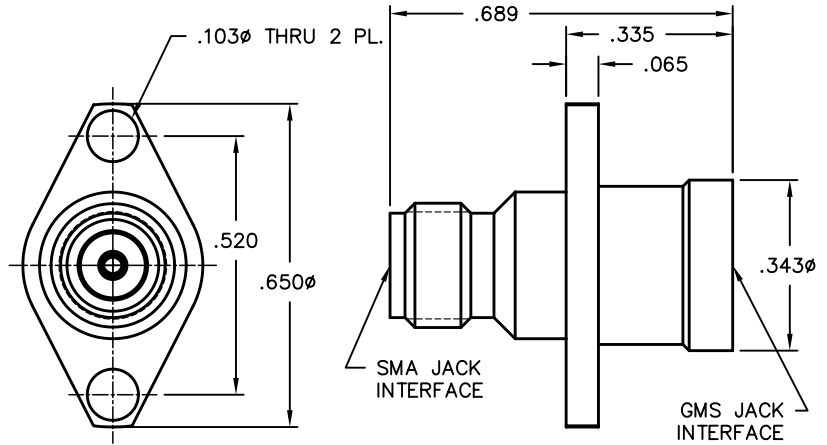

GMS Plug to SMA Jack

Catalog Number

1F1H2-0503-01

VSWR (TYP)

1.10:1 to 18 GHz, 1.20:1 to 23 GHz

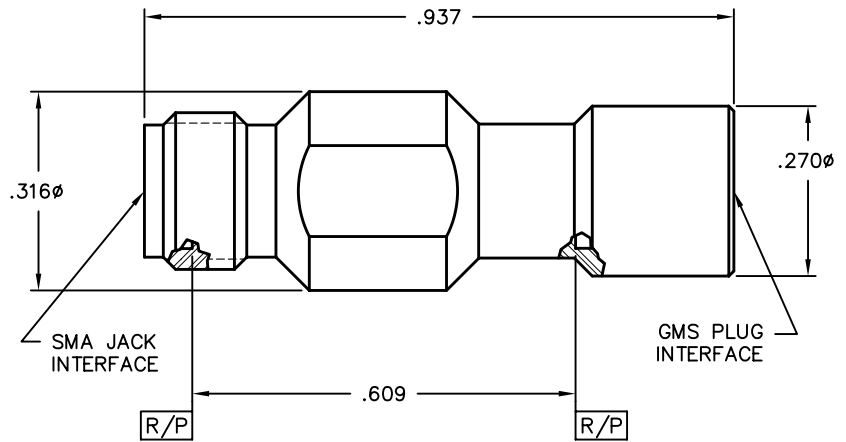

GMS Plug to SMA Jack

Catalog Number

00218-301-3

VSWR (TYP)

1.20:1 to 18 GHz, 1.30:1 to 23 GHz

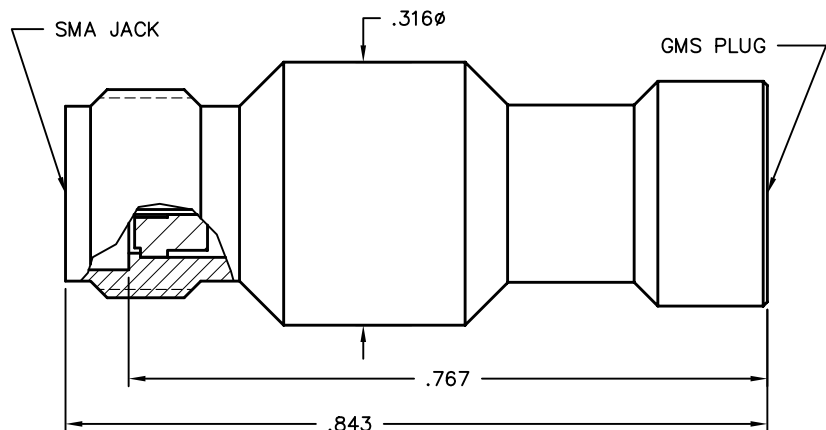

GMS Adapters

GMS Jack to SMA Jack

Catalog Number

1F1H1-0501-01

VSWR (TYP)

1.20:1 to 18 GHz, 1.30:1 to 23 GHz

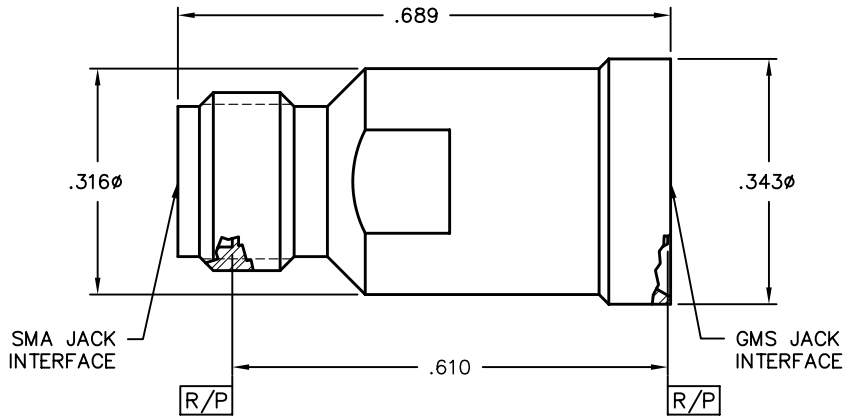

GMS Jack to SMA Plug

Catalog Number

1F2H1-0501-01

VSWR (TYP)

1.20:1 to 23 GHz

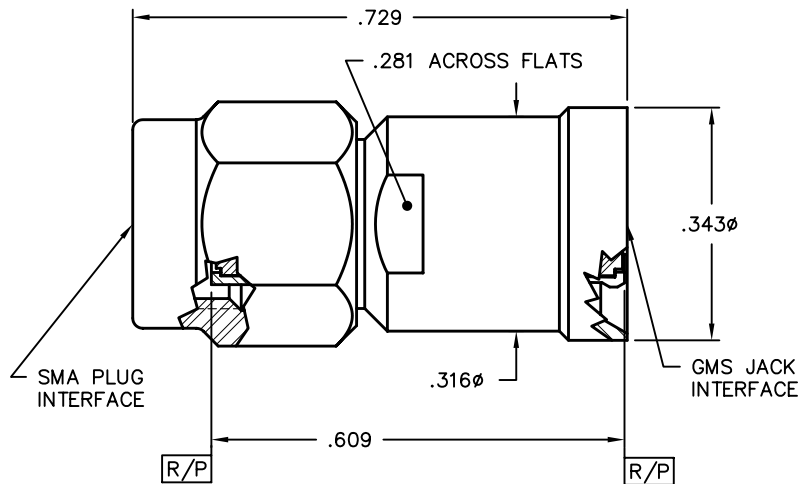

GMS Plug to SMA Plug

Catalog Number

1F2H2-0503-01

VSWR (TYP)

1.20:1 to 18 GHz, 1.30:1 to 23 GHz

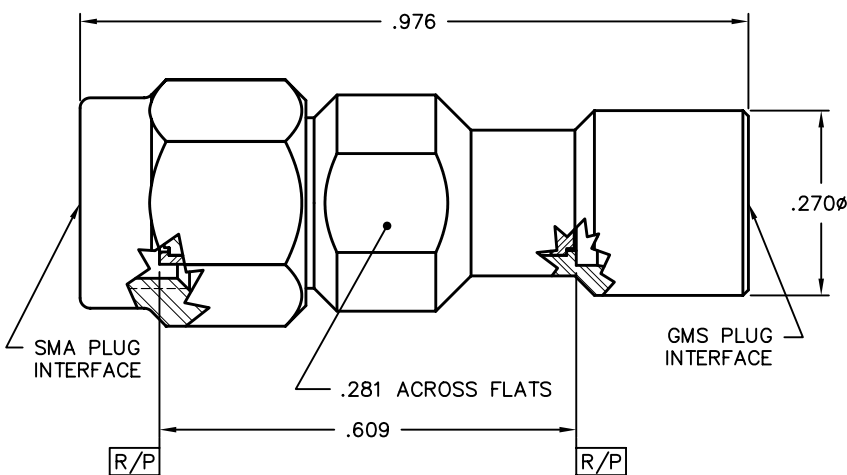

GMS Adapters

GMS Jack 2-Hole Flange Mount to GPO Male FD Adapter

Catalog Number

1A3H1-0511-01

VSWR (TYP)

1.20:1 to 23 GHz

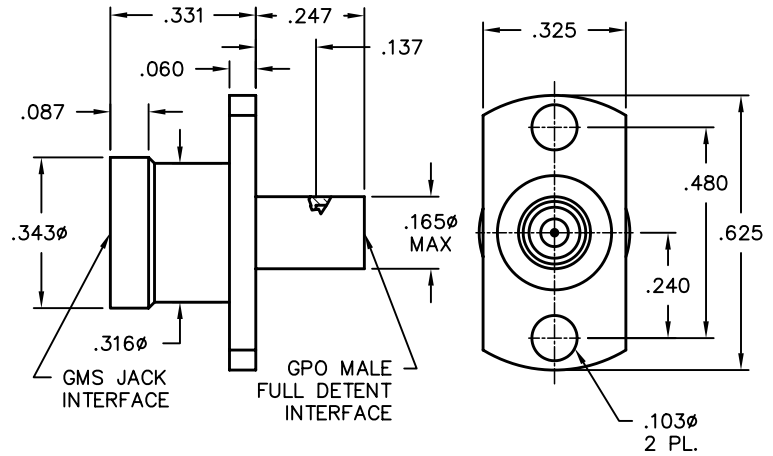

GMS Plug to GPO Male FD Snap-in Float Mount

Catalog Number

1A3H2-0533-01

VSWR (TYP)

1.20:1 to 18 GHz, 1.30:1 to 23 GHz

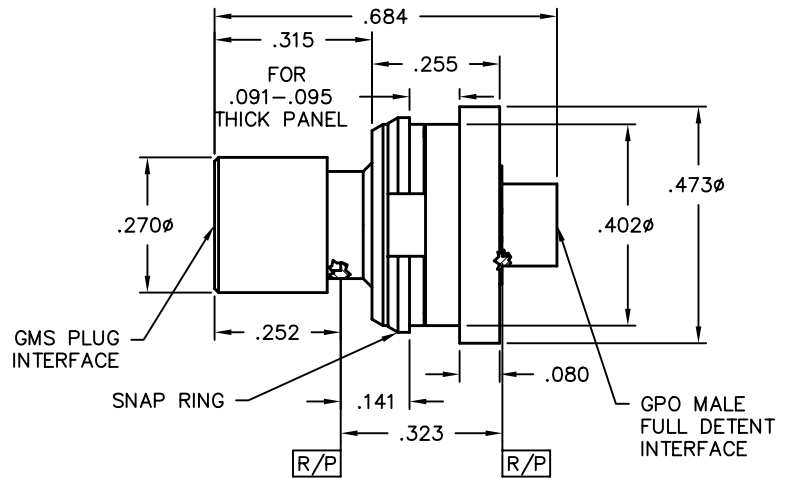

GMS Jack to GPO Male LD Bulkhead Mount

Catalog Number

00118-119-3-LD

VSWR (TYP)

1.20:1 to 18 GHz, 1.30:1 to 23 GHz

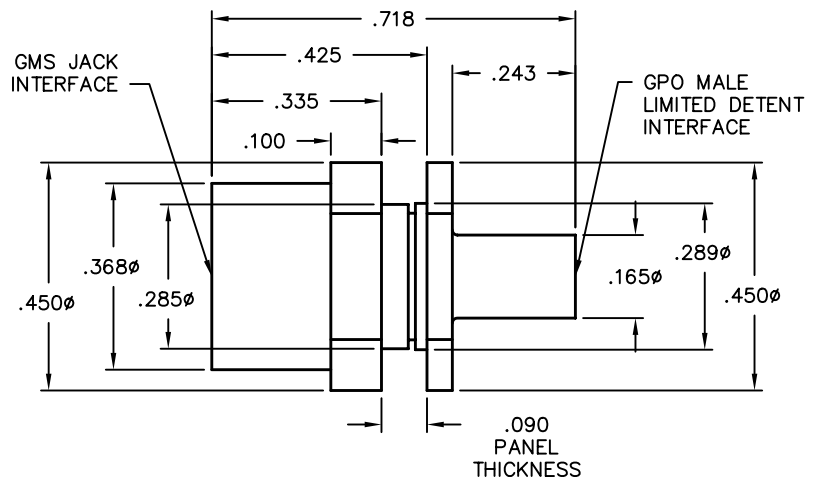

GMS ESD Adapters

GMS ESD Male Plug to SMA Jack

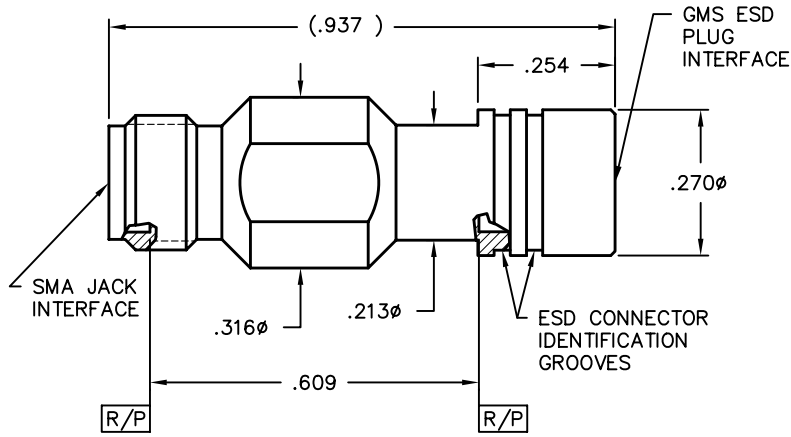

Catalog Number

02018-318-3

VSWR (TYP)

1.20:1 to 18 GHz, 1.30:1 to 23 GHz



GMS ESD Jack to SMA Plug

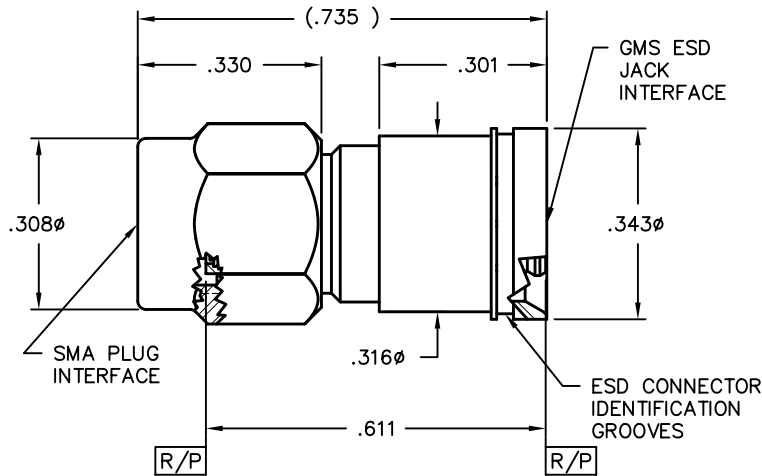

Catalog Number

02018-317-3

VSWR (TYP)

1.20:1 to 18 GHz, 1.30:1 to 23 GHz



GMS ESD Plug to SMA Plug

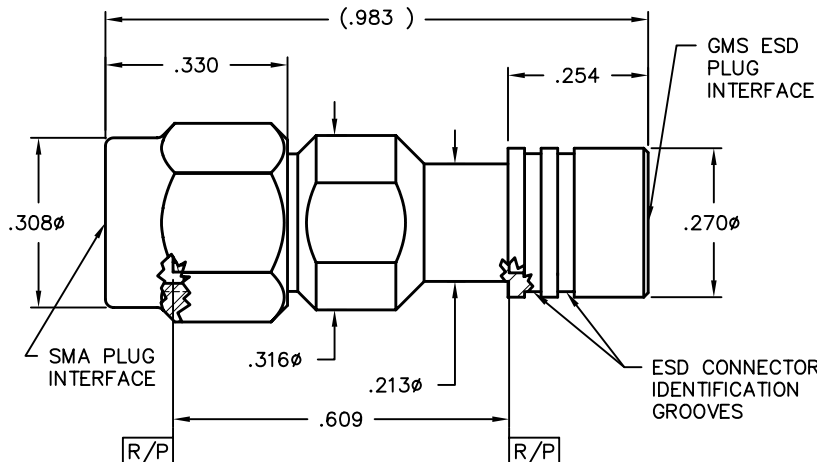

Catalog Number

02018-316-3

VSWR (TYP)

1.20:1 to 18 GHz, 1.30:1 to 23 GHz



GMS ESD Adapters

GMS ESD Plug Float Mount to SMA Jack

Catalog Number
02018-315-3

VSWR (TYP)
1.20:1 to 18 GHz, 1.30:1 to 23 GHz

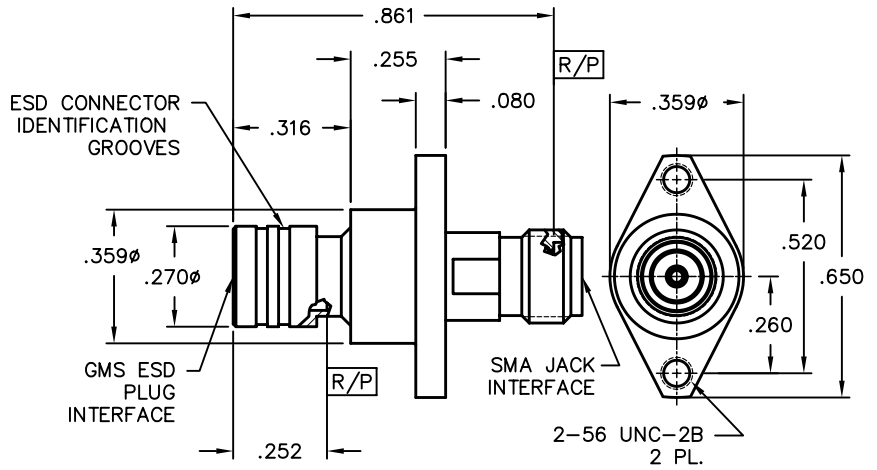

GMS ESD Jack 2-Hole Flange Mount to GPO Male FD

Catalog Number
02018-320-4

VSWR (TYP)
1.20:1 to 18 GHz, 1.30:1 to 23 GHz

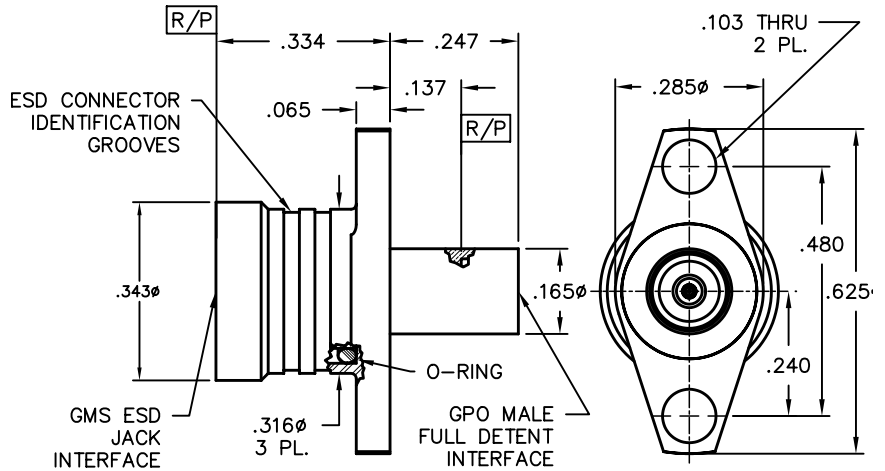

SGMS Adapters

SGMS Jack to SMA Plug Adapter

Catalog Number
00218-201-3

VSWR (TYP)
1.10:1 to 8 GHz, 1.20:1 to 23 GHz

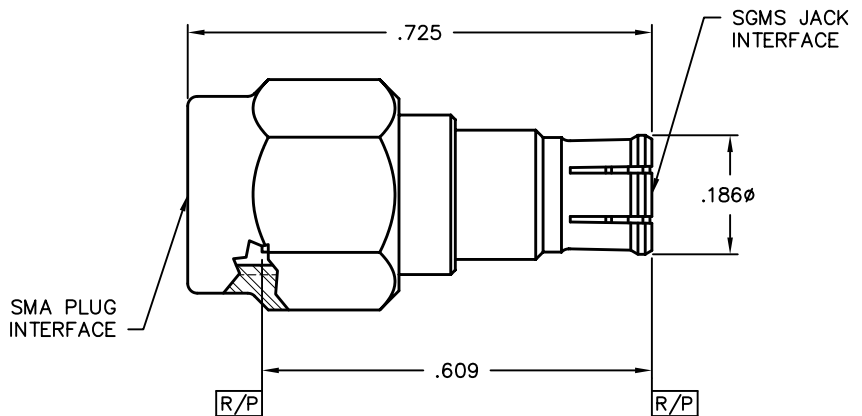

SGMS Adapters

SGMS Jack to SMA Jack Adapter

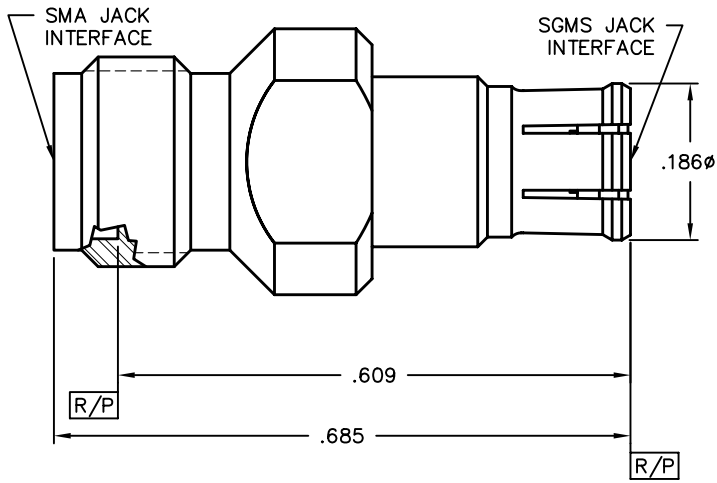

Catalog Number

00218-101-3

VSWR (TYP)

1.10:1 to 12 GHz, 1.20:1 to 23 GHz

SGMS Plug to SMA Jack Adapter

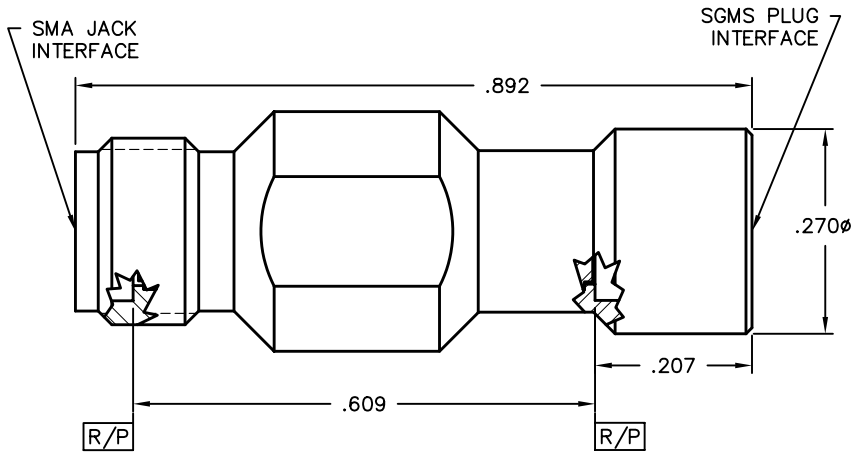

Catalog Number

1F1P5-0503-01

VSWR (TYP)

1.10:1 to 18 GHz, 1.20:1 to 26.5 GHz

Tools

10012







Bullet Install/Removal Tool Guide

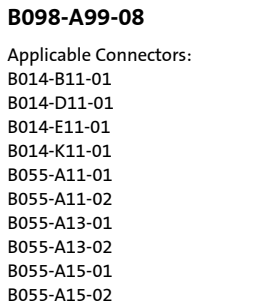
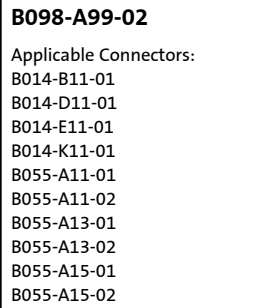
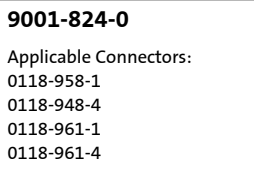
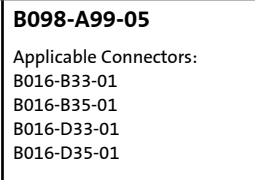

Since the introduction of the industry’s first push-on connector series (GPO®) in the 1980s, Corning Gilbert created a variety of tools to facilitate repeatable implementation of these connectors. With each technological innovation, our tools are designed in tandem and proven in the field. Corning Gilbert’s wide variety of tools improves manufacturability and can increase the life of your connectors.

Contact us to discuss how we may customize our tools to meet **your** specific application requirements.
 Customer Service: 800-651-8869 (toll free) or (01) 623-845-5613 (international).

GPO Tools			
BMI Installation/Removal Tool	A095-A99-01 Applicable Connectors: A1A1-0001-XX* *XX = All GPO Blindmate Interconnect	A095-A99-03 Low Impact Removal Applicable Connectors: A1A1-0001-01 A1A1-0001-02 A1A1-0001-06 A1A1-0001-07 A1A1-0001-23	
Straight Cable Removal Tool	A098-A98-08 Applicable Connectors: A014-B11-01 A014-D11-01 A014-D11-02 A014-F71-01 A014-H71-01 A014-K11-01	A098-A99-10 Applicable Connectors: A014-B11-01 A014-D11-01 A014-D11-02 A014-F71-01 A014-H71-01 A014-K11-01	A098-A99-02 Applicable Connectors: A014-B11-01 A014-D11-01 A014-D11-02 A014-F71-01 A014-H71-01 A014-K11-01
Snap-in Removal Tool	A098-A99-05 Female Connector Removal Applicable Connectors: A018-B71-01 A018-B71-02 A018-D11-01 A018-F71-01 A1A1-0547-01	9001-820-4 Male Connector Removal Applicable Connectors: A016-K53-01 0119-237-3 0119-240-3	
Thread-in Drivers	A097-A99-01 Applicable Connectors: A003-A23-01 A003-L33-02 A003-N33-01 0119-258-3-FD	A097-A99-02 Applicable Connectors: A003-A24-01 A003-L34-02 A003-N34-01 0119-258-3-LD	A097-A99-03 Applicable Connectors: A003-A25-01 A003-L35-02 A003-N35-02 0119-258-3-SB

GPPO Tools				
BMI Installation/ Removal Tool	B095-A99-01 Applicable Connectors: B1B1-0001-XX* *XX = All GPPO Blindmate Interconnect		B095-A99-05 Low Impact Removal Applicable Connectors: B1B1-0001-01 B1B1-0001-04	
				
Straight Cable Removal Tool	B098-A99-08 Applicable Connectors: B014-B11-01 B014-D11-01 B014-E11-01 B014-K11-01 B055-A11-01 B055-A11-02 B055-A13-01 B055-A13-02 B055-A15-01 B055-A15-02	B098-A99-07 Applicable connectors: B014-B11-01 B014-D11-01 B014-E11-01 B014-K11-01 B055-A11-01 B055-A11-02 B055-A13-01 B055-A13-02 B055-A15-01 B055-A15-02	B098-A99-03 Applicable Connectors: B014-B11-01 B014-D11-01 B014-E11-01 B014-K11-01 B055-A11-01 B055-A11-02 B055-A13-01 B055-A13-02 B055-A15-01 B055-A15-02	B098-A99-02 Applicable Connectors: B014-B11-01 B014-D11-01 B014-E11-01 B014-K11-01 B055-A11-01 B055-A11-02 B055-A13-01 B055-A13-02 B055-A15-01 B055-A15-02
				
Snap-in Removal Tool	9001-824-0 Applicable Connectors: 0118-958-1 0118-948-4 0118-961-1 0118-961-4		B098-A99-05 Applicable Connectors: B016-B33-01 B016-B35-01 B016-D33-01 B016-D35-01	
				
Thread-in Drivers	B097-A99-01 Applicable Connectors: B003-A23-01 B003-L33-01 B003-L33-02 B003-L33-03 B003-L33-06 B003-N33-01 B003-N33-02 B024-L33-01 B024-L33-02		B097-A99-02 Applicable Connectors: B003-A25-01 B003-L35-01 B003-L35-02 B003-L35-03 B003-L35-06 B003-N35-01 B003-N35-02 B024-L35-01 B024-L35-02	
				

G3PO Tools	
BMI Installation/Removal Tool	R095-A99-01 Applicable Connectors: B1B1-0001-01
Straight Cable Removal Tool	R098-A99-01 Applicable Connectors: R014-B11-01 R014-B13-01 R014-B15-01 R014-K11-01 R055-A11-01 R055-A13-01 R055-A15-01

G4PO Tools		
BMI Installation/Removal Tool	S094-A91-01 Installation Applicable Connectors: S1S1-0001-01	S095-A99-01 Removal Applicable Connectors: S1S1-0001-01
		

GPO Tools

GPO Seal Locating Tool for Thread-in Shroud

Catalog Number

A090-A99-01

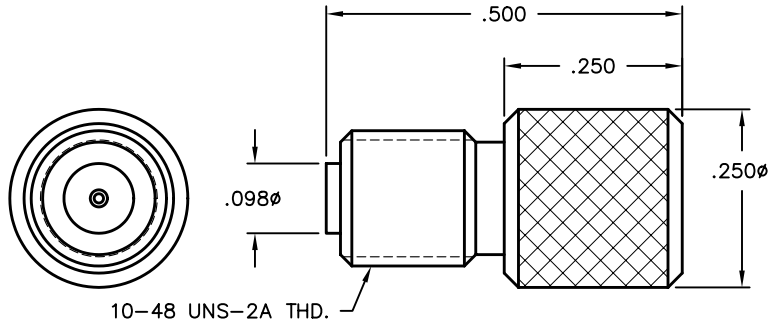

GPO Shroud Centering Tool for 0.015 C/C

Catalog Number

A090-A99-03

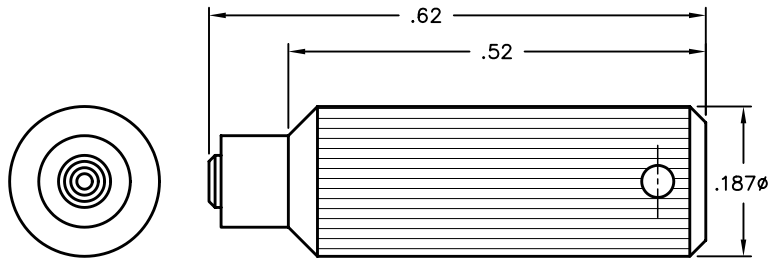

GPO Seal Locating Tool for Thread-in Shroud

Catalog Number

A090-A99-07

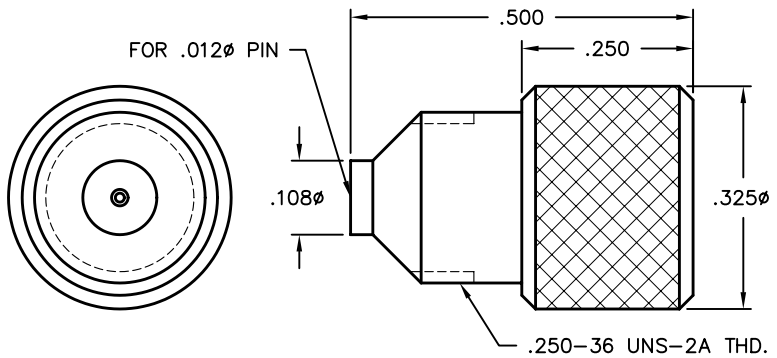

Flange Seal Locator Tool for 0.481 Hole

Catalog Number

A090-A99-09

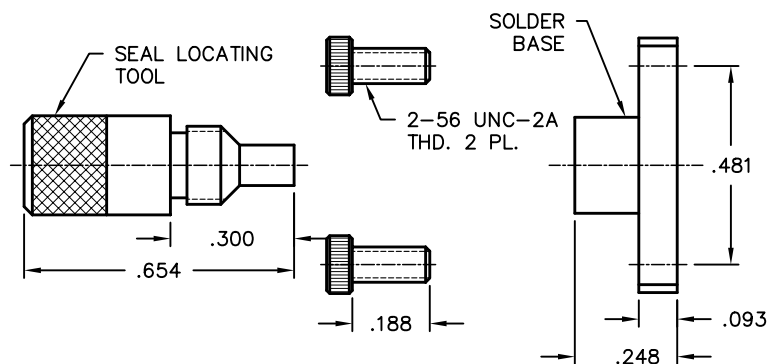

GPO Tools

Flange Seal Locator Tool for 0.282 Hole

Catalog Number
A090-A99-10

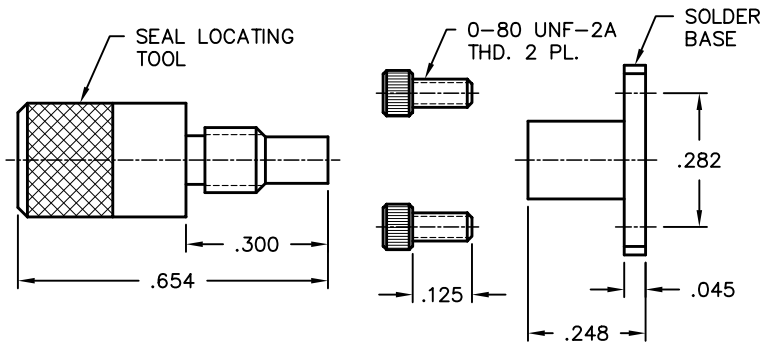

Flange Seal Locator Tool for 0.328 Hole

Catalog Number
A090-A99-11

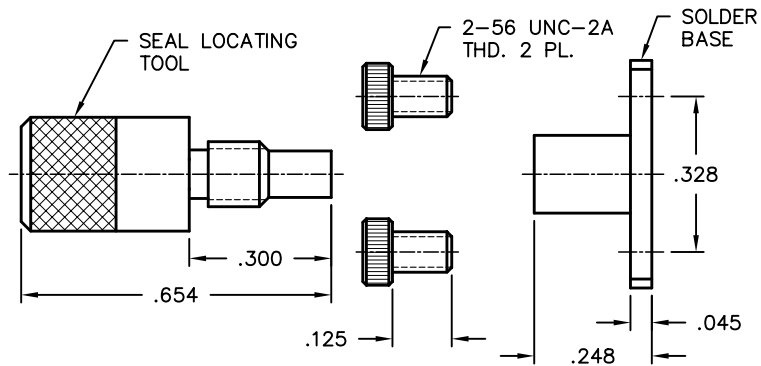

GPO Contact Retaining Tool

Catalog Number
A096-A99-01

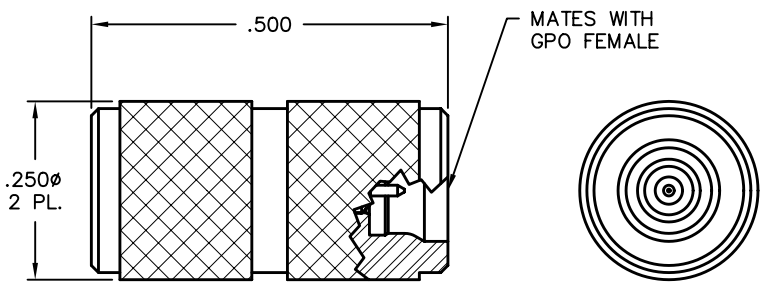

GPO Contact Locating Tool

Catalog Number
A096-A99-02

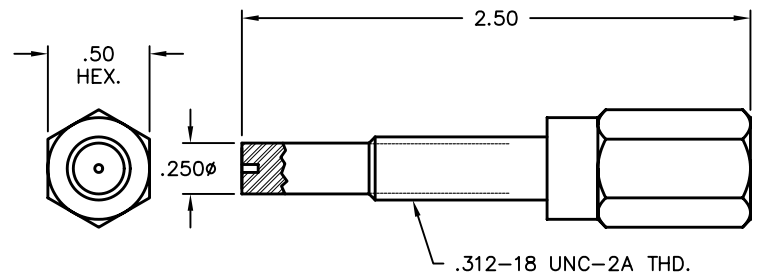

GPO Tools

GPO Contact Locating Tool

Catalog Number

A096-A99-04

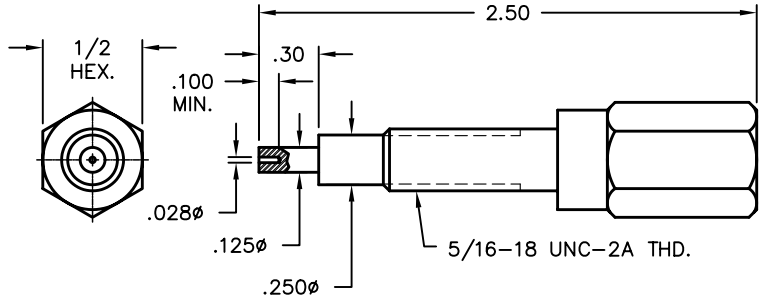

GPO Female Locator Tool

Catalog Number

A096-A99-06

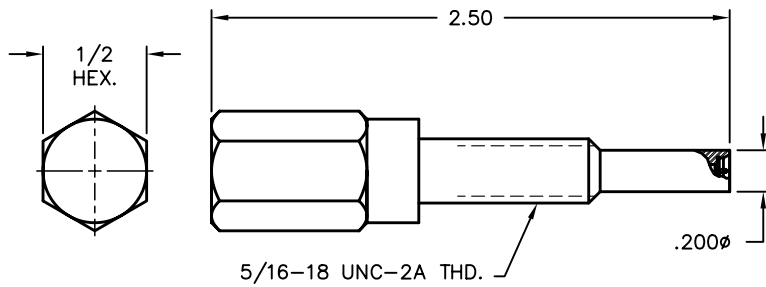

GPO R/A Locator Tool for Round Housing

Catalog Number

A096-A99-07

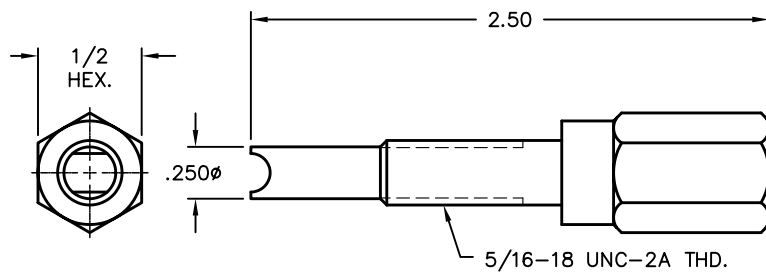

GPO R/A Locator Tool for Square Housing

Catalog Number

A096-A99-08

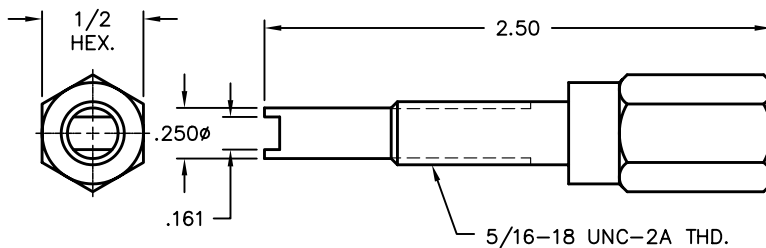

GPO Tools

GPO R/A Locator Tool

Catalog Number

A096-A99-09

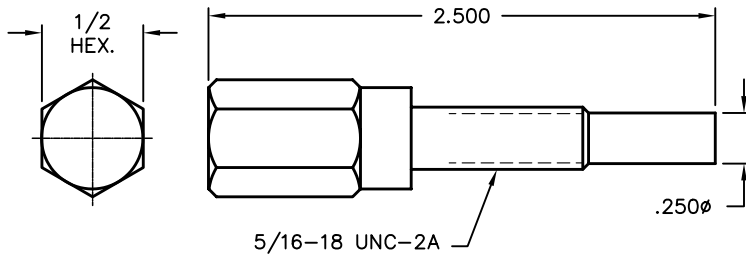

GPO Female R/A Installation Tool

Catalog Number

A098-A99-04

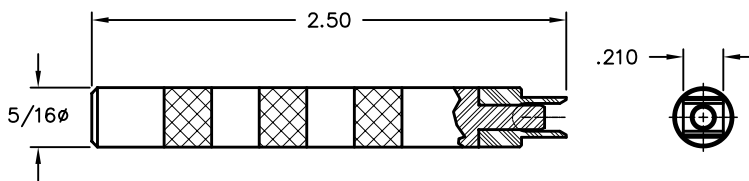

GPO BMI Installation/Removal Tool

Catalog Number

A095-A99-01*

* For use with all GPO Blindmate Interconnects

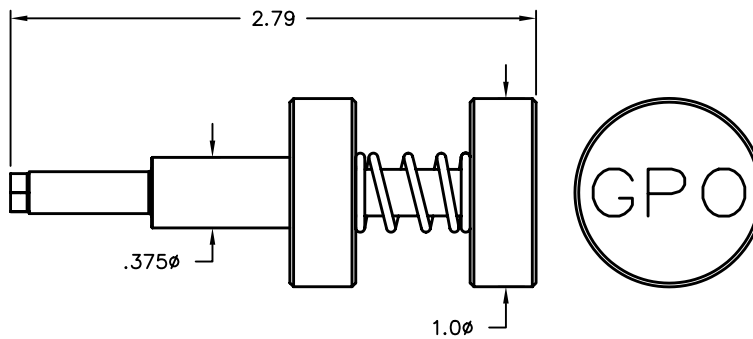

GPO Low Impact BMI Removal Tool

Catalog Number

A095-A99-03*

* For use with A1A1-0001-01

Additional alternate tips available for use with this tool:

A099-A99-02-395
(for A1A1-001-14 Bullet)

A099-A99-02-485
(for A1A1-001-10 Bullet)

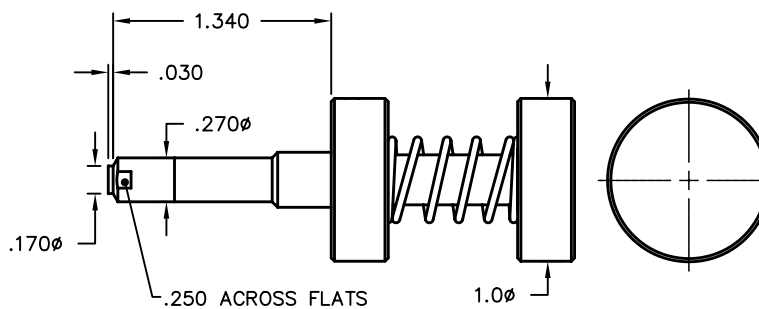

GPO Tools

GPO Low Impact Cable Connector Removal Tool

Catalog Number
A098-A99-08

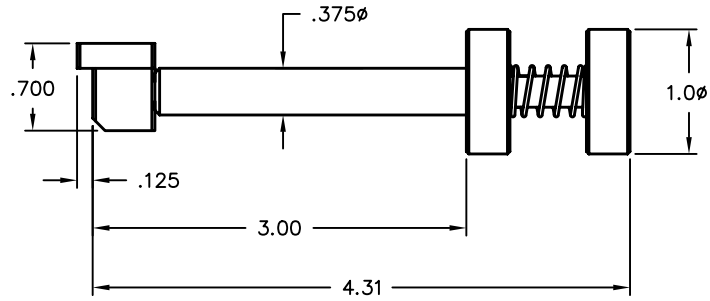

GPO Low Impact Load Removal Tool

Catalog Number
A093-A99-01

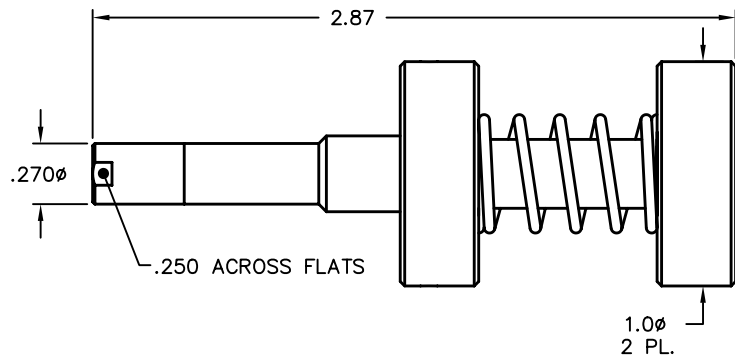

GPO R/A Removal Tool

Catalog Number
A098-A99-01

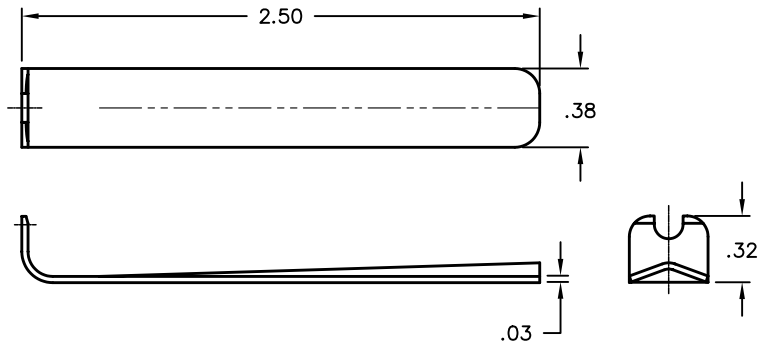

Installation/Withdrawal Tool (GPO R/A and Cable)

Catalog Number
A098-A99-02

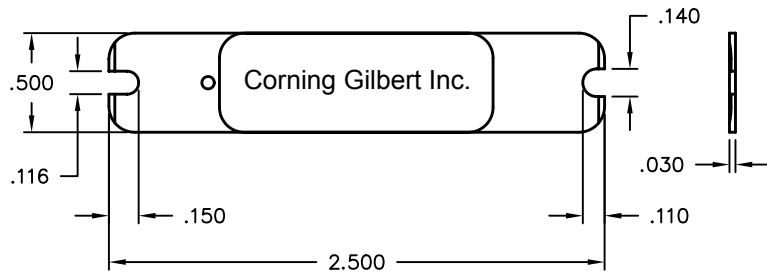

GPO Tools

GPO Pry Bar Removal Tool

Catalog Number

A098-A99-03

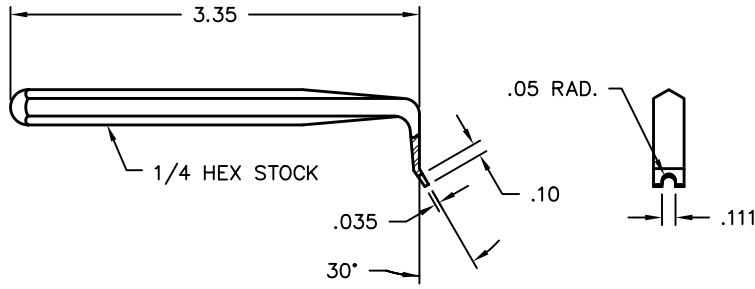

GPO Snap-in Float Mount Removal Tool

Catalog Number

A098-A99-05

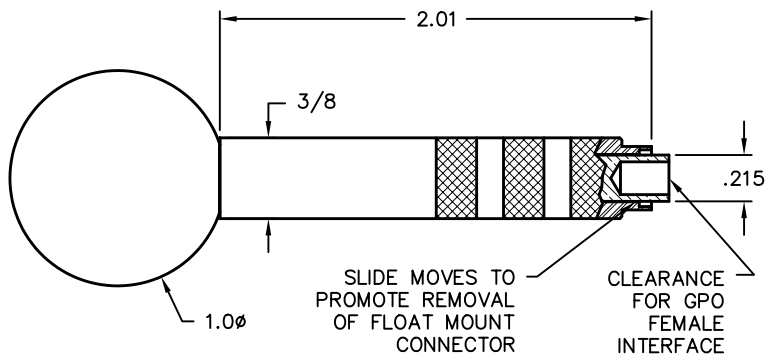

GPO Low Impact Straight Cable Connector Removal Tool

Catalog Number

A098-A99-10

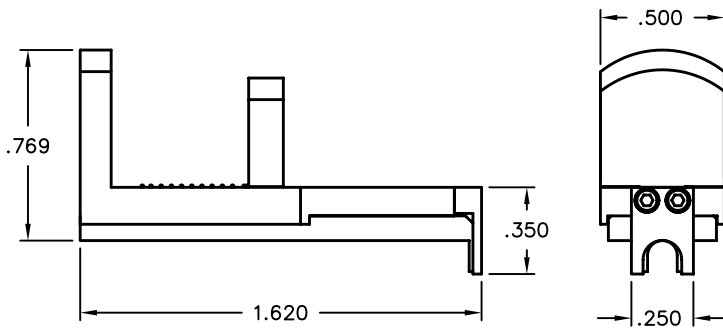

GPP0 Tools

GPP0 Seal Locator Tool for Thread-in Shroud

Catalog Number

B090-A99-05

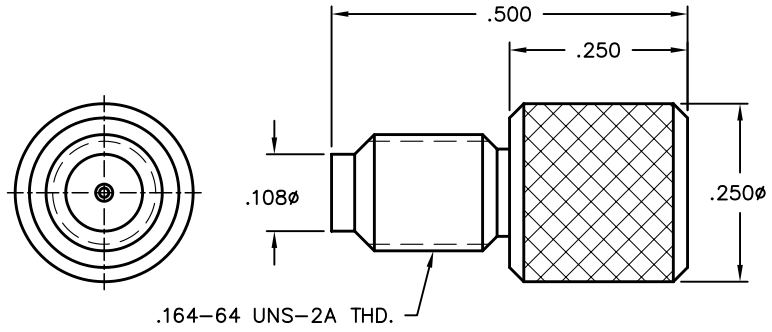

GPP0 Contact Retaining Tool

Catalog Number

B096-A93-01

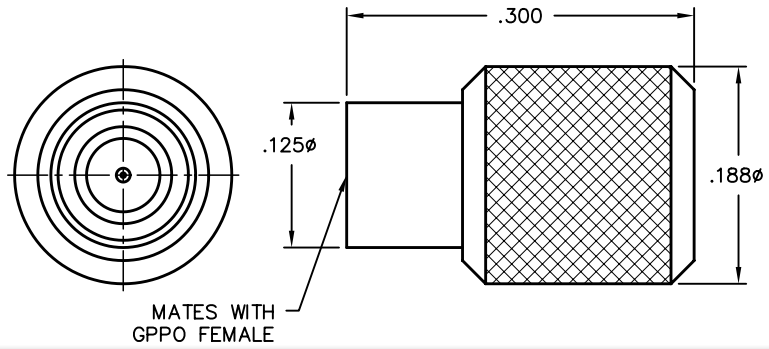

GPP0 Locator Tool

Catalog Number A

B096-A99-01 FD

B096-A99-02 SB

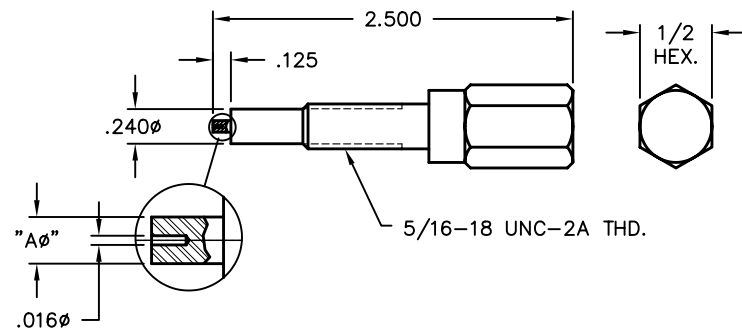

GPP0 Female R/A Installation Tool

Catalog Number

B098-A99-01

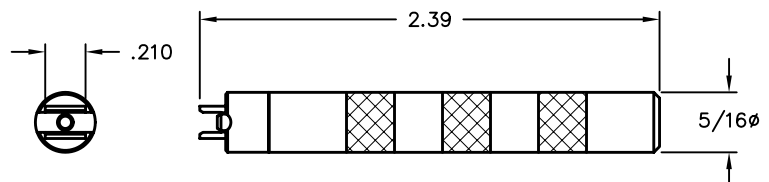

GPPO Tools

GPPO 30° Removal Tool

Catalog Number
B098-A99-02

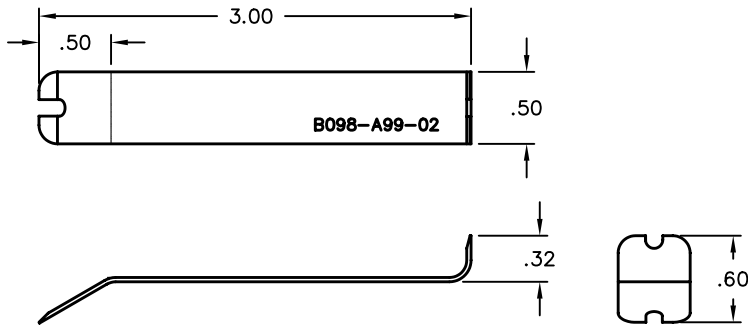

GPPO Removal Tool

Catalog Number
B098-A99-03

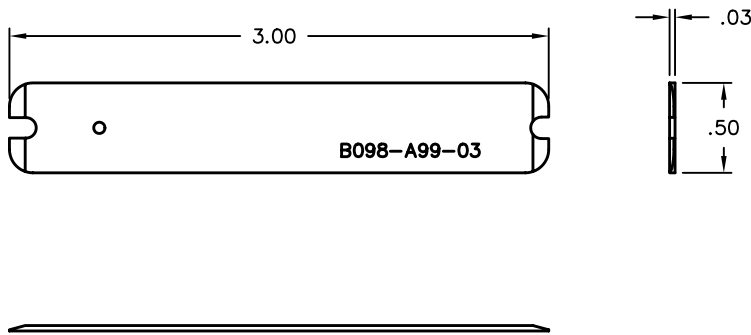

**GPPO Seal Locator Tool
for Press-in Shroud**

Catalog Number
B090-A99-06

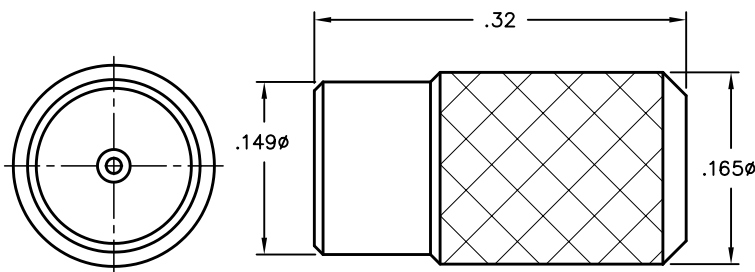

**Seal Locator Tool
for Thread-in Shroud**

Catalog Number
B090-A99-07

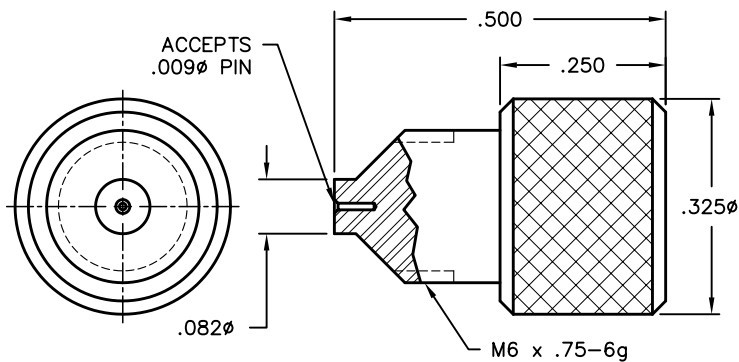

GPPO Tools

GPPO BMI Installation/Removal Tool

Catalog Number

B095-A99-01*

* For use with all GPPO Blindmate Interconnects

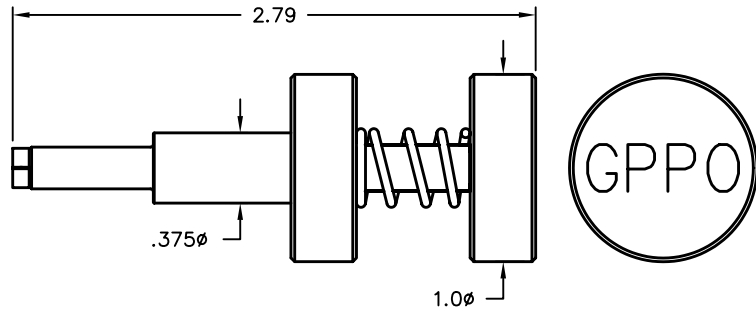

GPPO Low Impact BMI Removal Tool

Catalog Number

B095-A99-05*

* For use with B1B1-0001-01

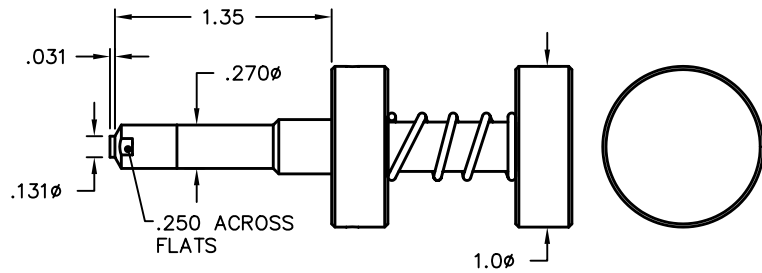

GPPO Low Impact Straight Cable Connector Removal Tool

Catalog Number

B098-A99-08

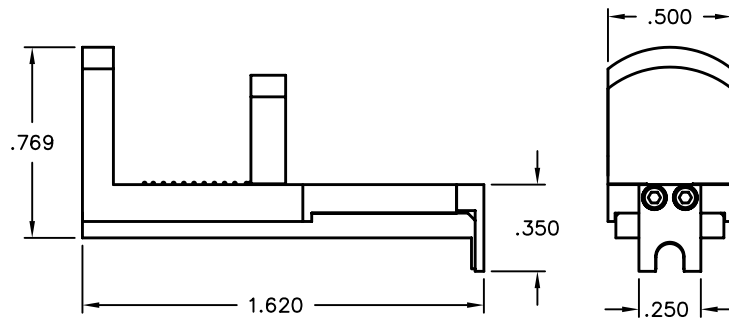

GPPO Low Impact Cable Connector Removal Tool

Catalog Number

B098-A99-07

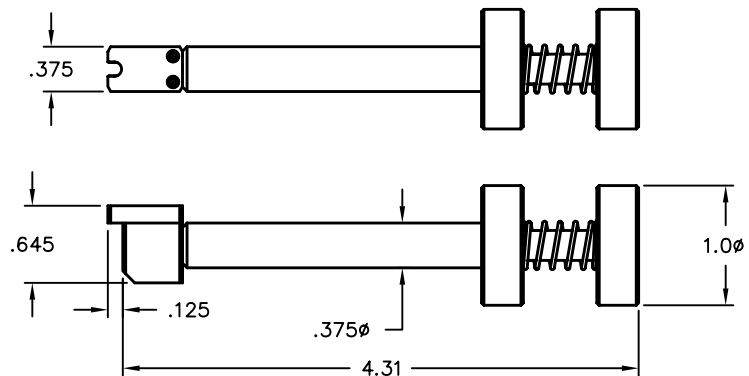

GPPO Tools

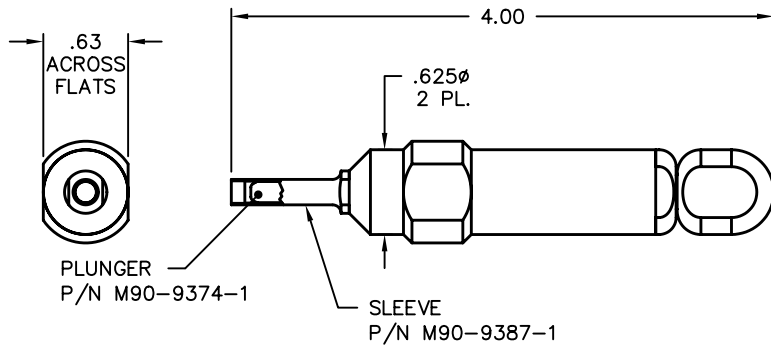

GPPO Male Snap-in Removal Tool

Catalog Number

9001-823-0*

* For use with part number 0118-928-4

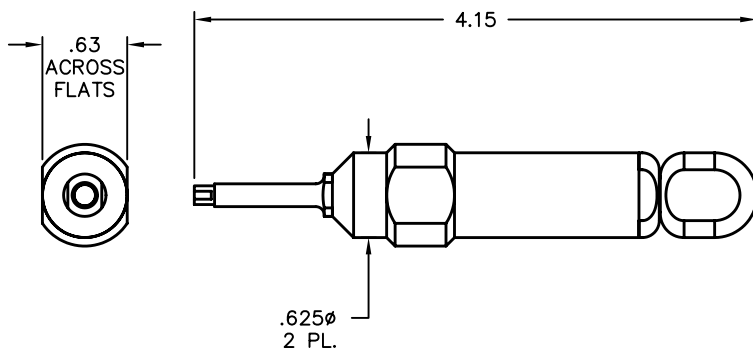

GPPO Female Snap-in Removal Tool

Catalog Number

9001-824-0*

* For use with part numbers 0118-958-1 and B016-B11-01

G3PO Tools

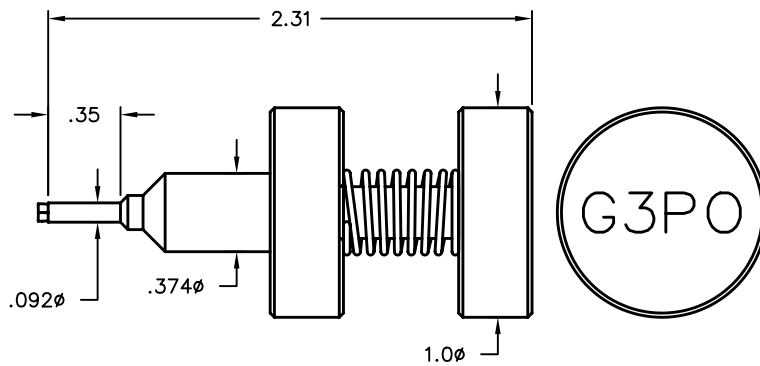

G3PO BMI Install/Removal Tool

Catalog Number

R095-A99-01

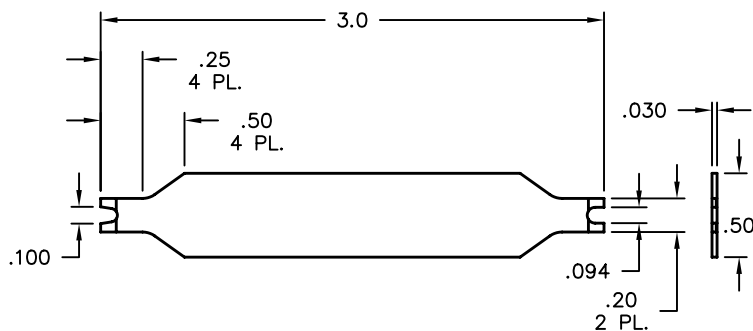

G3PO Removal Tool

Catalog Number

R098-A99-01

G4PO Tools

G4PO BMI Removal Tool

Catalog Number

S095-A99-01

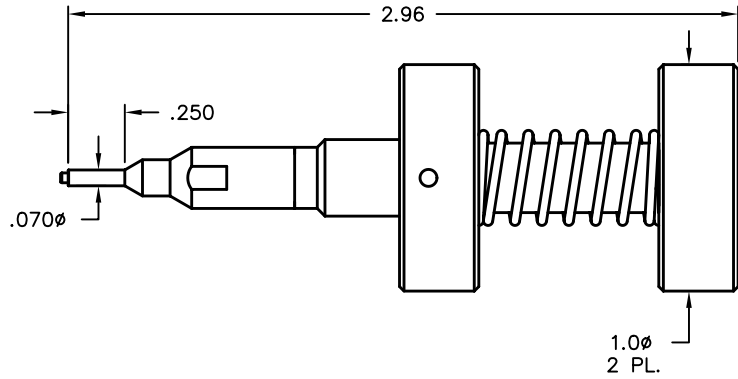

G4PO BMI Installation Tool

Catalog Number

S094-A91-01

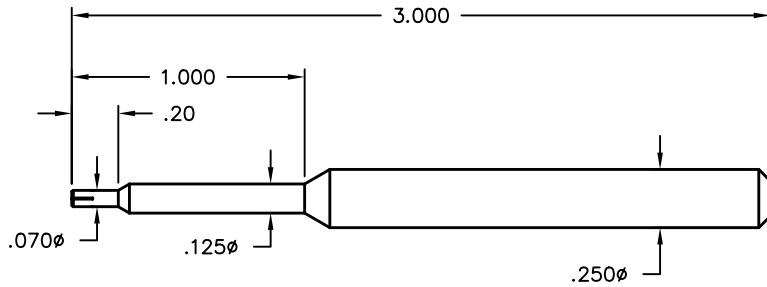

GMS Tools

GMS Removal Tool

Catalog Number

H098-A99-01

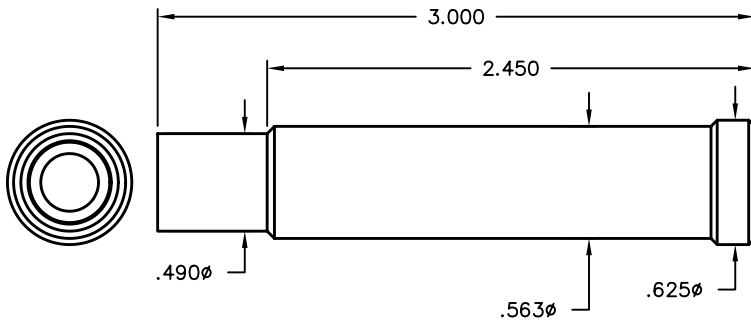

GMS Male Locator Tool

Catalog Number

H096-A99-01

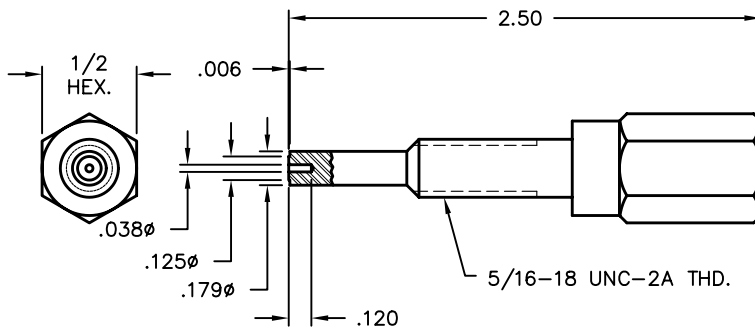

Housing Locator Tool

Catalog Number

A096-A99-09

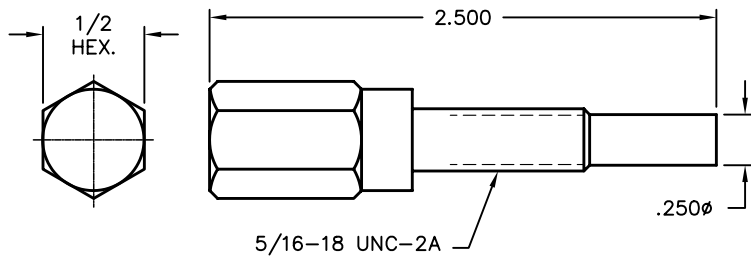

Miscellaneous Tools

Cable Holding Fixture for Semi-Rigid Cable

Catalog Number	Cable Ø
L096-A99-01	.086
L096-A99-02	.047

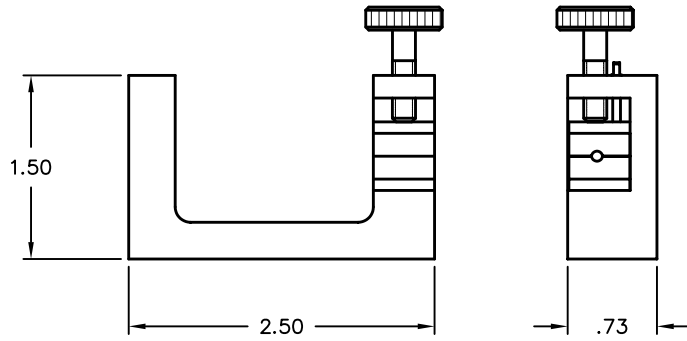

Cable Holding Fixture for 0.141 Cable

Catalog Number
L096-A99-10

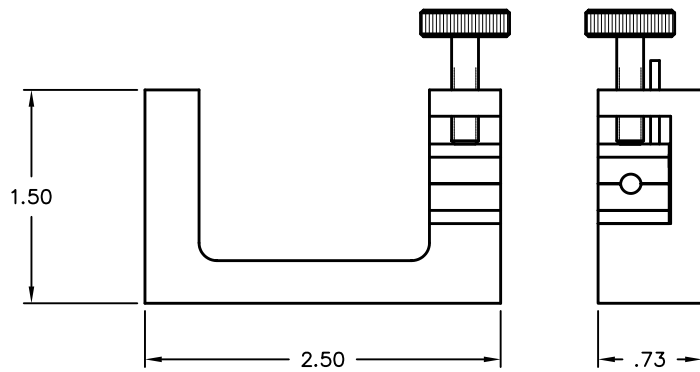

Shim Gauge

Catalog Number
L096-A99-03

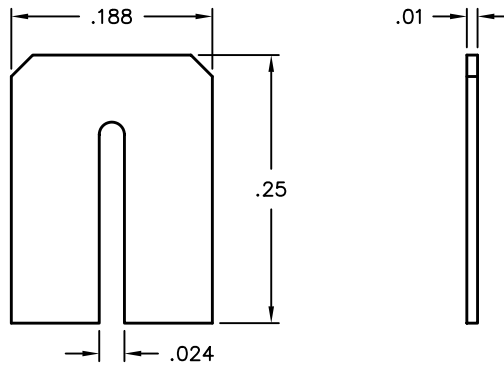

Technical Guide

Cable Assemblies

In addition to providing our worldwide customers with superior connectors and components, at Corning Gilbert, we also offer cable assemblies as an integrated, value-added service. Our goal is to provide our customers with the shortest lead time and lowest priced solution for cabled Corning Gilbert connectors. To accomplish this, we:

- Specialize in single plane, semi-rigid and flexible commercial and military test application cable assemblies.
- Make custom test inspection document available upon the customer’s request.
- Provide excellent lead times.
- Help you find the right connector for your system by granting access to customized point-to-point solutions.



Please see the list below for all available Corning Gilbert connectors and its associated cable types.

Corning Gilbert Connector Type	Cable Types	Impedance	Frequency Range
GPO	RG-178, RG-316, .086 Semi Rigid, Storm Products 120 and 421-720	50 Ohm	DC to 26.5 GHz
GPPO	.047 and .086 Semi Rigid, Storm Products 421-721	50 Ohm	DC to 65 GHz
G3PO	.047 Semi Rigid and .058 Flex	50 Ohm	DC to 65 GHz
SMA	RG-316, .047, .086 and .141 Semi Rigid, Storm Products 120 and 421-1110	50 Ohm	DC to 26.5 GHz
GMS	.086 and .141 Semi Rigid	50 Ohm	DC to 26.5 GHz
TNC	.086, and .141 Semi Rigid, Belden 9292	50 and 75 Ohm	DC to 11 GHz
BNC	RG-59, HEC 59	50 and 75 Ohm	DC to 4 GHz
N	RG-59, RG-6, RG-11, RG-8, RG-223/224, .086, .141 and .250 Semi Rigid, Storm Products 190 and 385	50 and 75 Ohm	DC to 11 GHz
F	RG-178, RG-179, RG-59, RG-6, RG-11, HEC 59	50 and 75 Ohm	DC to 1 GHz is typical, High Performance types available to 3 GHz.
SMB	RG-316, RG-179	50 and 75 Ohm	DC to 4 GHz
MCX	RG-316, RG-179	50 and 75 Ohm	DC to 6 GHz
MMCX	RG-316, RG-179	50 and 75 Ohm	DC to 6 GHz

Test Capabilities

Corning Gilbert’s commitment to quality has made it a leader in the connector industry. Mechanical and electrical quality is verified in every lot of connectors via the internal standard testing procedures. These standard tests include, but are not limited to:

- Visual and Mechanical Inspection
- Dielectric Withstanding Voltage
- Hermetic Seal
- Leakage
- Force to Engage/Disengage
- Mating Characteristics
- Permeability
- Insulation Resistance
- VSWR

All tests listed above are standard and part of groups A and B testing, per MIL-PRF-39012. As part of our internal test procedure, ATP-1000, they are free of charge to our customers.

Expanded testing may be obtained by requesting ATP-2000. This test includes all of ATP-1000, as well as 100% Thermal Shock testing and 100% Visual and Mechanical inspection. Corning Gilbert also has an in-house capability to perform Salt Spray and Moisture Resistance testing.

Since many Corning Gilbert connectors are utilized in military or aerospace applications, custom Test Inspection Documents are created on a regular basis for those requiring heightened or special testing. The TIDs verify compliance to the customers’ requests and/or their submitted SCDs.

Whether you are looking for a commercial, off-the-shelf part or need extensive qualification and acceptance testing, Corning Gilbert can assure you and your customers that the parts you need are the parts you receive.

Connector Evaluation Kits

Corning Gilbert offers evaluation kits for the GPO® and GPPO® cable connectors. These kits include everything one would need for the assembly and trial of our GPO and GPPO connectors.



A099-A99-03 GPO Evaluation Kit Includes:

- 4 ea – A014-D11-01 – Female Straight to .086 Cable
- 4 ea – A015-D11-01 – Female Right Angle to .086 Cable
- 6 ea – 6 lengths of .086 S/R cable
- 1 ea – 1A3F1-0503-01 – GPO (m) to SMA (f) adapter
- 1 ea – 1A3F2-0503-01 – GPO (m) to SMA (m) adapter
- 1 ea – A096-A99-06 – Straight Locator Tool
- 1 ea – A096-A99-07 – Right Angle Locator Tool
- 1 ea – A096-A99-01 - Center Contact Positioning Tool
- 1 ea – L096-A99-01 – .086 Assembly Fixture
- Appropriate Assembly Procedures



B099-A99-13 GPPO Evaluation Kit Includes:

- 4 ea – B014-B11-01 – Female Straight to .047 Cable
- 4 ea – B015-B11-01 – Female Right Angle to .047 Cable
- 6 ea – 6 lengths of .047 S/R cable
- 1 ea – 1B3F1-0503-01 – GPPO (m) to SMA (f) adapter
- 1 ea – 1B3F2-0503-01 – GPPO (m) to SMA (m) adapter
- 1 ea – A096-A99-04 – Straight Locator Tool
- 1 ea – 9001-984-0 – Right Angle Locator Tool
- 1 ea – B096-A93-01 - Center Contact Positioning Tool
- 1 ea – L096-A99-02 – .047 Assembly Fixture
- Appropriate Assembly Procedures

Assembly Procedures

The following general assembly procedure* defines both GPO and GPPO, straight and right angle cable connectors, for both semi rigid and flexible cable. For further assistance, or if the connector you are using is not found, please contact Corning Gilbert for specific assembly procedures.

1.0 Cable preparation

- 1.1 Cut the cable to length required.
- 1.2 For semi rigid cable, score the outer conductor with a razor blade or a semi rigid trim tool. Reference tables I-IV, Trim Length B, for distance from the end of the cable to the score mark.

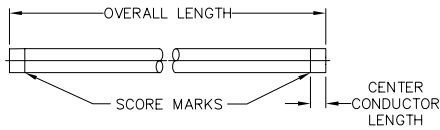

Note: Different trim lengths may apply, dependent upon the type of GPO connector being installed. The dielectric may be cut flush with the outer conductor or may be stepped.

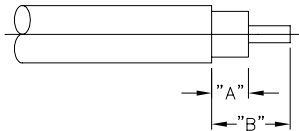

Table I: GPO Straight

Part Number	Trim Length A	Trim Length B
A001-B83-01	N/A	.085
A001-D83-01	N/A	.085
A014-B11-01	N/A	.090
A014-D11-01	.020 - .025	.075
A014-D11-02	N/A	.060
A014-H71-01	.060	.150

Table III: GPPO Straight

Part Number	Trim Length A	Trim Length B
B014-B11-01	.020 - .025	.065
B014-D11-01	N/A	.055
B014-E11-01	N/A	.055
B016-B11-01	.100	.180
B016-B33-01	.020 - .025	.065
B016-D33-01	N/A	.040 .050

Table II: GPO Right Angle

Part Number	Trim Length A	Trim Length B
A015-B11-01	.025	.065
A015-D11-01	.025	.060
A015-D11-03	N/A	.045
A015-B71-01	N/A	.080
A015-F71-01	.120	.215
A015-H71-01	.250	.340

Table IV: GPPO Right Angle

Part Number	Trim Length A	Trim Length B
B015-B11-01	.025	.060
B015-B11-02	.010 - .015	.060
B015-D11-01	N/A	.045
B015-D11-02	.075 - .080	.180

- 1.3 Whether the cable is now formed per specification or remains straight, the semi rigid cable should be temperature cycled to aid dielectric stability. Flexible cable does not need to be temperature cycled.
- 1.4 Thoroughly clean S/R cable outer conductor using fine grain sandpaper or steel wool as indicated, then wipe area clean with denatured alcohol or an equivalent cleaner.

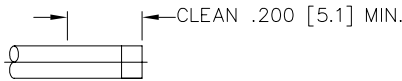

* Applications may vary. These instructions are to be used as guidelines only. All dimensions are in inches.

- 1.5 Remove the semi rigid outer conductor with hole pliers or trim flexible cable accordingly. Do not nick the center conductor.

Note: It is recommended when working with flexible cable and solder-on connectors to make the cut on the jacket (at B), but do not completely remove the jacket at this point. Rather, slide the jacket to the end of the braid and then solder dip the cable so that the braid does not expand once the jacket is removed. When working with crimp-on connectors, a solder dip is not necessary.

- 1.6 Point and de-burr the center conductor.

2.0 Center contacts

The majority of Corning Gilbert’s right angled GPO and GPPO connectors have captivated contacts. Therefore, they do not require the extra step of soldering on a center conductor. Some of these connectors include: A015-B11-01, A015-D11-01, B015-B11-01 and B015-B11-02.

- 2.1 If required, place the dielectric stop and center conductor onto the cable as shown. If there is no dielectric stop, place the contact flush against the dielectric.

Note: In some cases, a shim is used to create an air gap between the dielectric and the center contact. The connectors on this AP which require the use of a .010 shim include: A014-D11-02, B014-E11-01 and B015-D11-02.

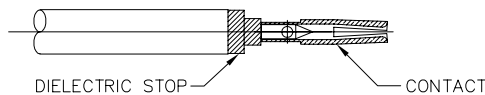

- 2.2 The following diagram supports Corning Gilbert’s standard tooling for all center contact soldering.

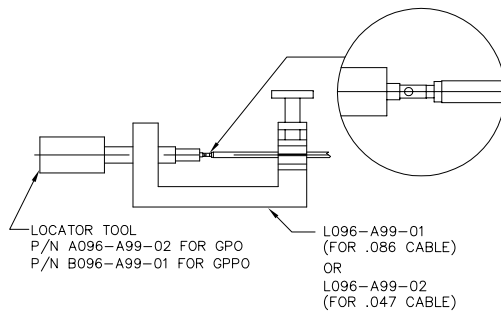

3.0 Solder center contact to cable inner conductor

- 3.1 Tin inner conductor of cable.
- 3.2 Place center contact in appropriate locator tool. Heat center contact and push it over inner conductor of cable to rest firmly against the supplied dielectric stop, shim or cable dielectric. Use a minimum amount of heat, for a limited time, with a maximum contact temperature of 550° F.
- 3.3 Remove excess solder.

* Applications may vary. These instructions are to be used as guidelines only. All dimensions are in inches.

4.0 Solder a straight female GPP0 connector to cable

- 4.1 Fixture as shown.
- 4.2 Apply liquid flux to joint as necessary.
- 4.3 Apply heat. Use of resistance soldering unit (hot tips) is required. Use minimum amount of heat and solder for a limited duration (550° F maximum temperature).
- 4.4 Allow to cool. Clean solder joint and remove excess flux.

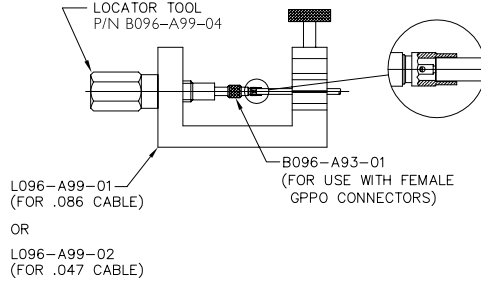

5.0 Solder right angle female GPP0 connector to cable

- 5.1 Fixture as shown.
- 5.2 Apply liquid flux to joint as necessary.
- 5.3 Apply heat. Use of resistance soldering unit (hot tips) is required. Use minimum amount of heat and solder for a limited duration (550° F maximum temperature).
- 5.4 Allow to cool. Clean solder joint and remove excess flux.

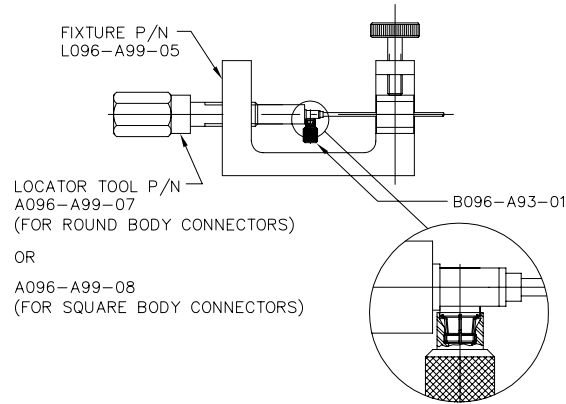

* Applications may vary. These instructions are to be used as guidelines only. All dimensions are in inches.

6.0 Solder a straight female GPO connector to cable

- 6.1 Fixture as shown.
- 6.2 Apply liquid flux to joint as necessary.
- 6.3 Apply heat. Use of resistance soldering unit (hot tips) is required. Use minimum amount of heat and solder for a limited duration (550° F maximum temperature).
- 6.4 Allow to cool. Clean solder joint and remove excess flux.

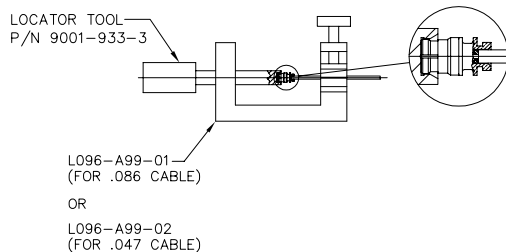

7.0 Solder right angle female GPO contact to cable

- 7.1 Install contact positioning tool A096-A99-01 on interface of connector.

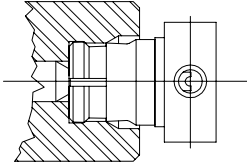

- 7.2 Carefully insert cable into housing. Cable center conductor must engage center contact of connector. Visually inspect cable junction from rear of connector as shown. Solder cable center conductor to center contact. Remove excess flux.

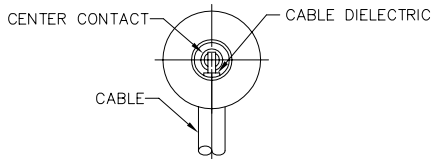

- 7.3 Remove connector from contact positioning tool.

* Applications may vary. These instructions are to be used as guidelines only. All dimensions are in inches.

8.0 Solder right angle female GPO connector to cable

- 8.1 Fixture as shown.
 8.2 Apply liquid flux to joint as necessary.
 8.3 Apply heat. Use of resistance soldering unit (hot tips) is required. Use minimum amount of heat and solder for a limited duration (550° F maximum temperature).
 8.4 Allow to cool. Clean solder joint and remove excess flux.

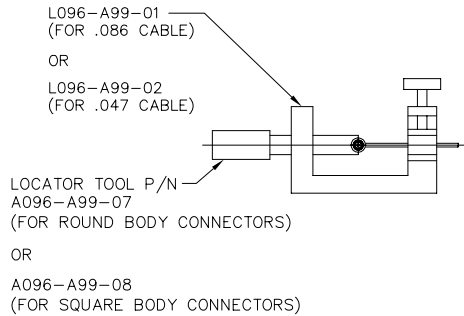

9.0 Install port plug for right angle GPO and GPPO

- 9.1 Orient plug as shown.
 9.2 Gently press plug until seated. Do no over press as damage to the unit will result.

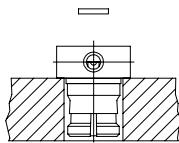

10.0 Interface dimensions

- 10.1 Adherence to these assembly procedures will yield interface dimensions shown.

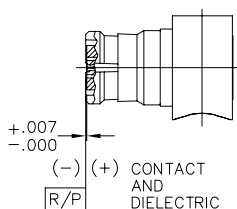

* Applications may vary. These instructions are to be used as guidelines only. All dimensions are in inches.

Custom Packaging

Corning Gilbert is a leader in designing custom solutions, whether it's with specialty connectors or for special packaging/delivery requirements. We maintain a large inventory of carrier tapes, as well as offer custom carrier tape designs for connectors that suit your application. Our in-house SMD tape and reel capabilities provide a turn-key solution with a quick turnaround, while maintaining compliance with EIA-481C.

Tape and Reel Options (100 pc. min.)

GPO	GPPO	G3PO
0119-248-1-TAB-T	B007-L45-01-T	R008-L1X-01-T
A007-L4X-13-T	B007-L43-03-T	R008-L1X-05-T
A007-L4X-10-T	B007-L45-04-012-T	R013-T1X-01-T
A009-P3X-01-T	B007-L45-15-T	
A010-L1X-02	B008-L1X-01-T	
A012-P9X-04-T	B009-P3X-01-T	
A012-P9X-06-T	B009-P3X-02-T	
	B010-L1X-09-T	
	B013-L9X-01	
	B030-L93-04-6-T	
	B036-L45-01-T	

NOTE:

X = detent-tabbed item:
 Indicate 3 for Full Detent
 Indicate 4 for Limited Detent
 Indicate 5 for Smooth Bore

T = pre-tinning

Not all detents are available for all connectors.

Other Packaging Options

In addition to tape and reel, we offer custom packaging that can be incorporated into various programs for quick and efficient distribution to the manufacturing floor. For example, highly compact Waffle Packs are designed to accommodate G3PO™ blindmate interconnects in excess of 200 pieces in trays as small as 2 x 2 x 0.5. Color coding, ESD and barcode labeling are also available options.

Tape and Reel

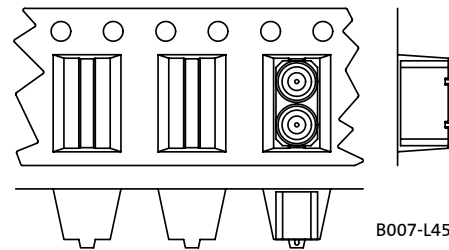

B007-L45-15-T@T13

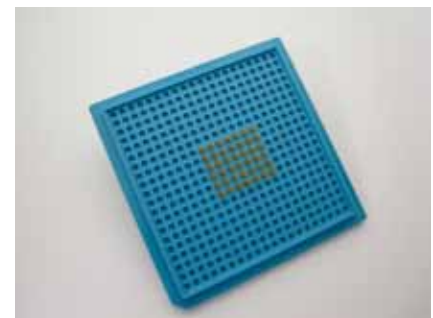

Waffle Pack

Application Notes

Table of Contents

Introduction

1.0 Materials and Finishes

2.0 GPO

- 2.1. Detent - Full, Limited, and Smooth Bore
- 2.2. Axial Misalignment
- 2.3. Radial Misalignment
- 2.4. VSWR and Insertion Loss

3.0 GPPO

- 3.1. Detent - Full and Smooth Bore
- 3.2. Axial Misalignment
- 3.3. Radial Misalignment
- 3.4. VSWR and Insertion Loss

4.0 G3PO

- 4.1. Detent - Full and Smooth Bore
- 4.2. Axial Misalignment
- 4.3. Radial Misalignment
- 4.4. VSWR and Insertion Loss

5.0 G4PO

- 5.1. Detent - Full and Smooth Bore
- 5.2. VSWR

6.0 SGMS

- 6.1. Detent - Limited and Smooth Bore
- 6.2. Axial Misalignment
- 6.3. Radial Misalignment
- 6.4. VSWR and Insertion Loss

7.0 Electrical - GPO, GPPO, G3PO, G4PO, and SGMS

- 7.1. General Electrical Specifications
- 7.2. Average Power Handling
- 7.3. Temperature / Altitude De-rating
- 7.4. VSWR De-rating

8.0 Board-to-Board Tolerance Analysis

- 8.1. GPO Typical
- 8.2. GPO Minimum
- 8.3. GPPO Typical
- 8.4. GPPO Minimum
- 8.5. G3PO Typical
- 8.6. G4PO Typical

Introduction

Corning Gilbert provides **push-on interconnect solutions** that are designed for blind mating and electrical performance when fully mated or mechanical misaligned. The push-on interface features ease of mating along with a high reliability electro-mechanical connection. This enables high density system flexibility while maintaining functionality from DC to 65 GHz.

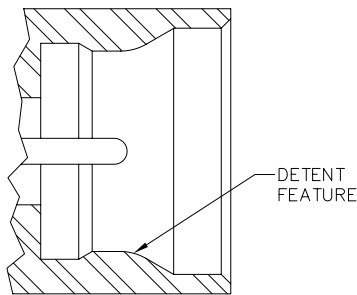

Figure 1 - Full Detent

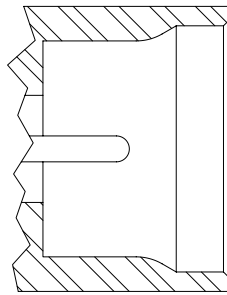

Figure 2 - Smooth Bore

Detent features are provided to retain the push-on connectors in the mated condition. Different levels of engage and disengage forces are accomplished by the stepped feature on the inside of the Shroud housing. Figure 1 shows the Full Detent interface which provides the highest mating forces and is recommended for use with cable connectors. Limited Detent interfaces are also available with reduced engage and disengage forces. Figure 2 shows the Smooth Bore interface which has the lowest mating forces (no stepped detent feature).

Module to module and board to board applications typically use a three connector system. One Blind-Mate Interconnect (BMI also know as a bullet) is mated between a Full Detent and a Smooth Bore Shroud. The Full Detent interface retains the BMI yet allows radial misalignment. The Smooth Bore interface allows misalignment in both radial and axial orientations.

Mechanical misalignment is the result of multiple component systems and the associated positional tolerances. **Axial misalignment** is the offset distance between the Shroud and BMI reference planes. For most connectors, coplanar reference planes provide the best electrical performance. Corning Gilbert can design connectors for optimal performance with a preset amount of axial misalignment. This enables good electrical performance with movement in both axial directions. **Radial misalignment** is the distance between the centerlines of the mated Shroud connectors. This is also know as gimbaling and is a directly related to the BMI length.

Figure 3 shows the BMI axially misaligned with an offset distance between the Shroud and BMI reference planes. The fully mated condition (no offset) is ideal for best electrical performance on most connectors.

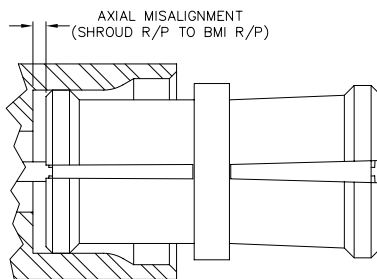

Figure 3 - Axial Misalignment

Figure 4 shows the BMI mated between two (2) connectors that are radially misaligned from centerline to centerline. The amount of radial misalignment is dependent upon the length and angle of the BMI. The GPO standard angle of 3° is mainly a function of the allowable connector housing movement.

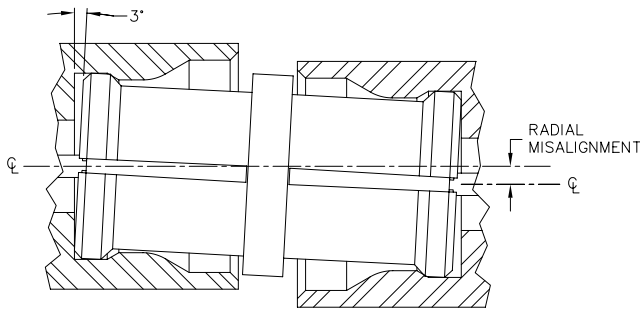

Figure 4 - Radial Misalignment

Various configurations are available such as Blind-Mate Interconnects, printed circuit board connectors, cable connectors, and hermetic panel connectors. The GPO connectors are also functionally compliant with the SMP interface of MIL-PRF-31031. Performance and reliability make Corning Gilbert the push-on connector of choice.

1.0 Materials and Finishes

Tables 1A, 1B, and 1C show the standard materials and finishes used to manufacture Corning Gilbert push-on connectors. This includes various configurations across all of the product families (GPO, GPPO, G3PO, G4PO, and SGMS).

Table 1A - Metal Materials

Material	Specification
BeCu (Beryllium Copper)	ASTM B 196 and/or ASTM B 197
Brass	ASTM B 36, B121, B16, B16M
Stainless Steel (303)	ASTM A484/ A582 or A555/581
Iron-Nickel-Cobalt	ASTM F-15

Table 1B - Metal Finishes

Finish	Specification
Gold (75u in. Typ)	ASTM-B488 Type 1, Class 1.25
Nickel (100u in. Typ)	SAE AMS-QQ-N-290

Table 1C - Dielectric Materials

Material	Specification
Virgin PTFE Fluorocarbon	ASTM D 1710 and ASTM D 1457
Polyamide-Imide	ASTM D5204 Group 2 Class 1
Glass	Corning 7070 or Equivalent

The characteristics of the above materials enable the standard Storage and Operating Temperature Range of -65 °C to +165 °C.

2.0 GPO

2.1 GPO Detents – Full, Limited, and Smooth Bore

Table 2 shows the available GPO detents, typical engage / disengage forces, and mating cycles.

Table 2 - GPO Detent Forces and Mating Cycles

Detent	GPO		
	Engage*	Disengage*	Cycles (Min)
Full	7.0	9.0	100
Limited	5.0	7.0	500
Smooth Bore	3.0	0.5	1000

* The engage / disengage force values (shown in pounds) are typical and based upon actual data.

2.2 GPO Axial Misalignment

Figure 5 shows the GPO VSWR electrical performance versus frequency and axial misalignment.

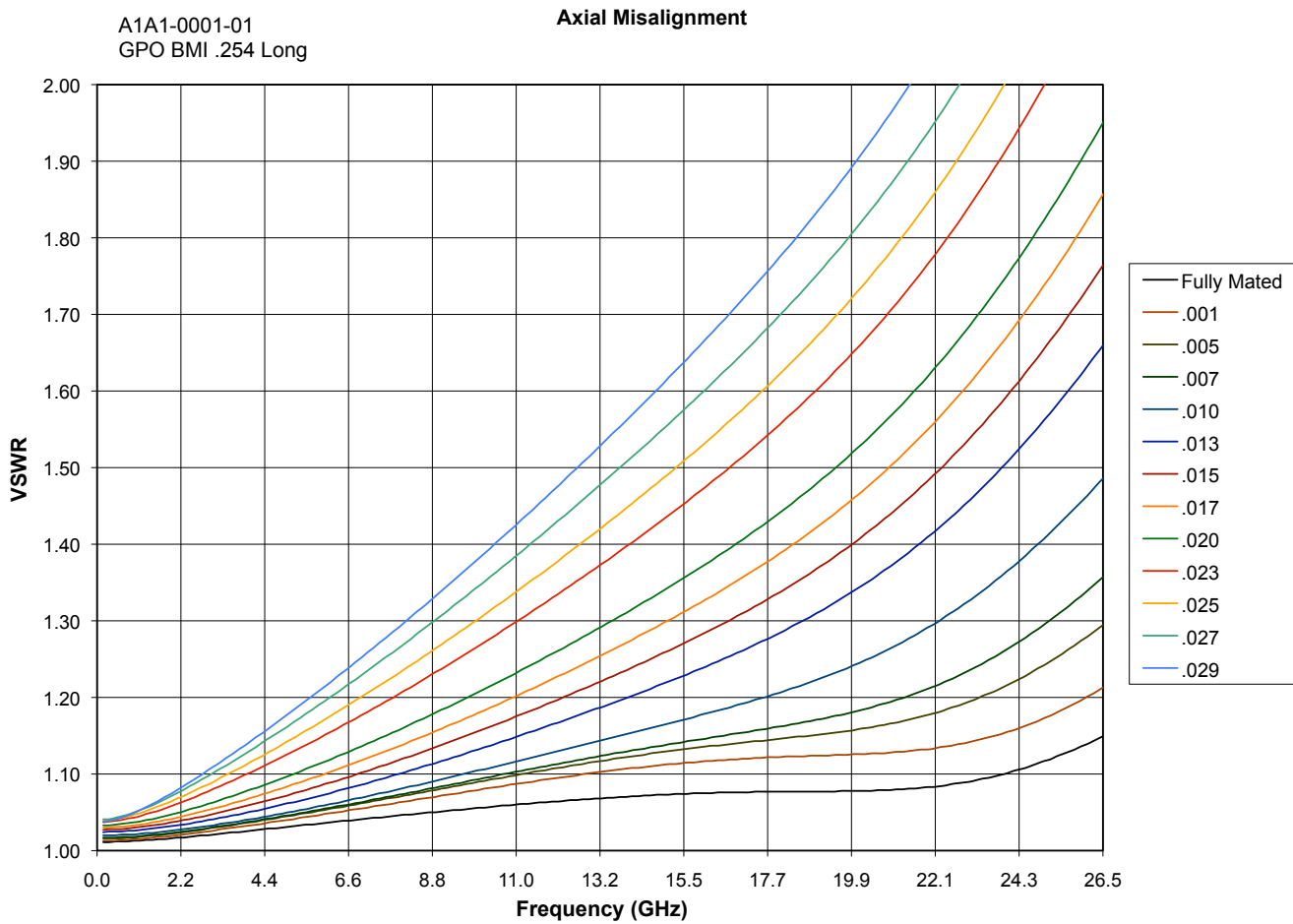

Figure 5 - GPO Axial Misalignment Performance

2.3 GPO Radial Misalignment

Figure 6 shows the GPO VSWR electrical performance versus frequency and radial misalignment.

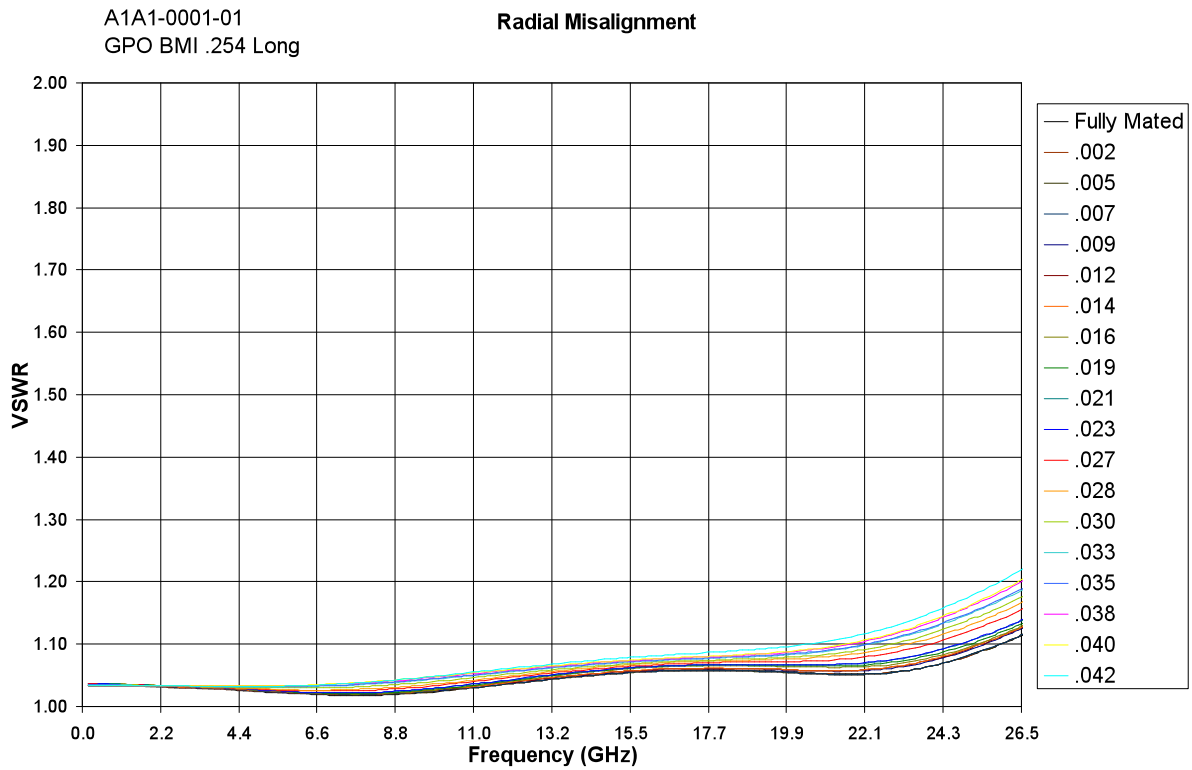

Figure 6 - GPO Radial Misalignment Performance

2.4 GPO VSWR and Insertion Loss

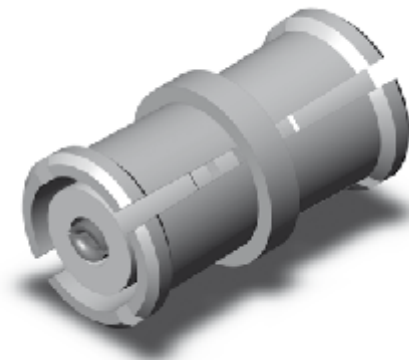

Figure 7 - GPO BMI A1A1-0001-01

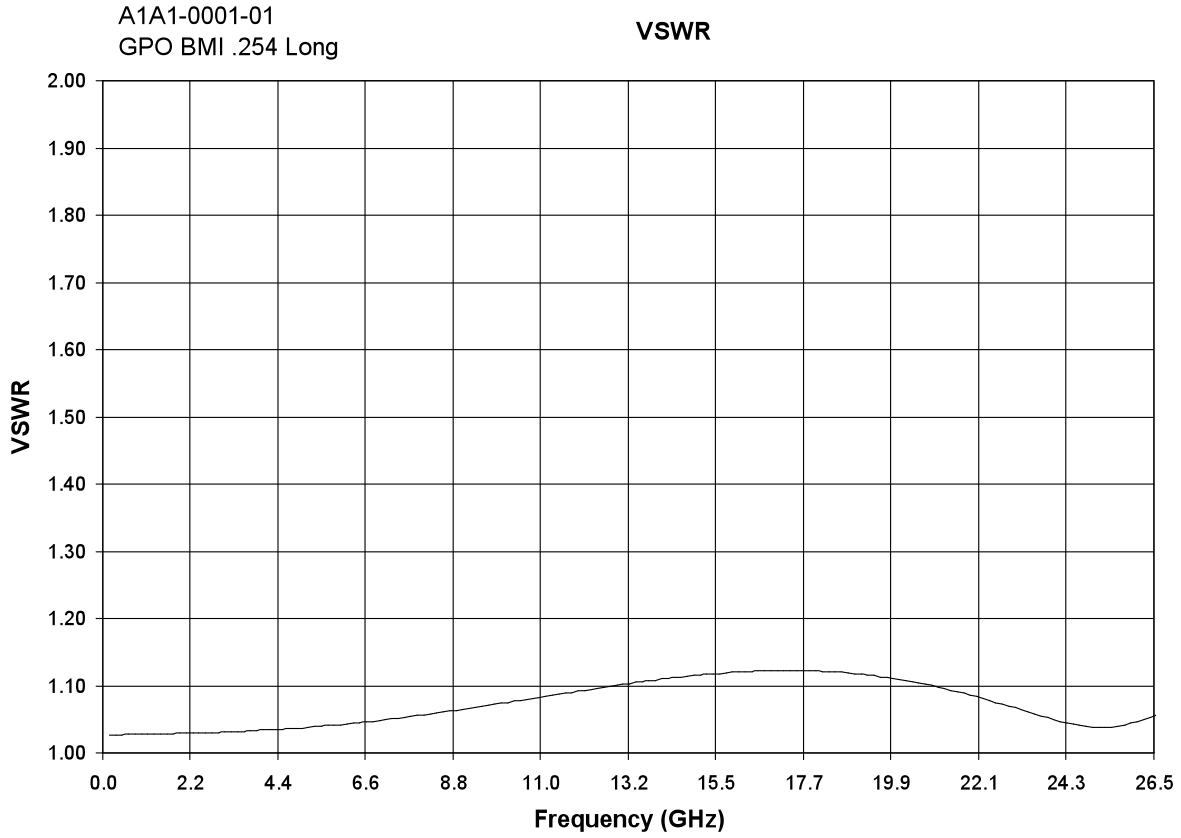

Figure 7A - GPO BMI VSWR Performance

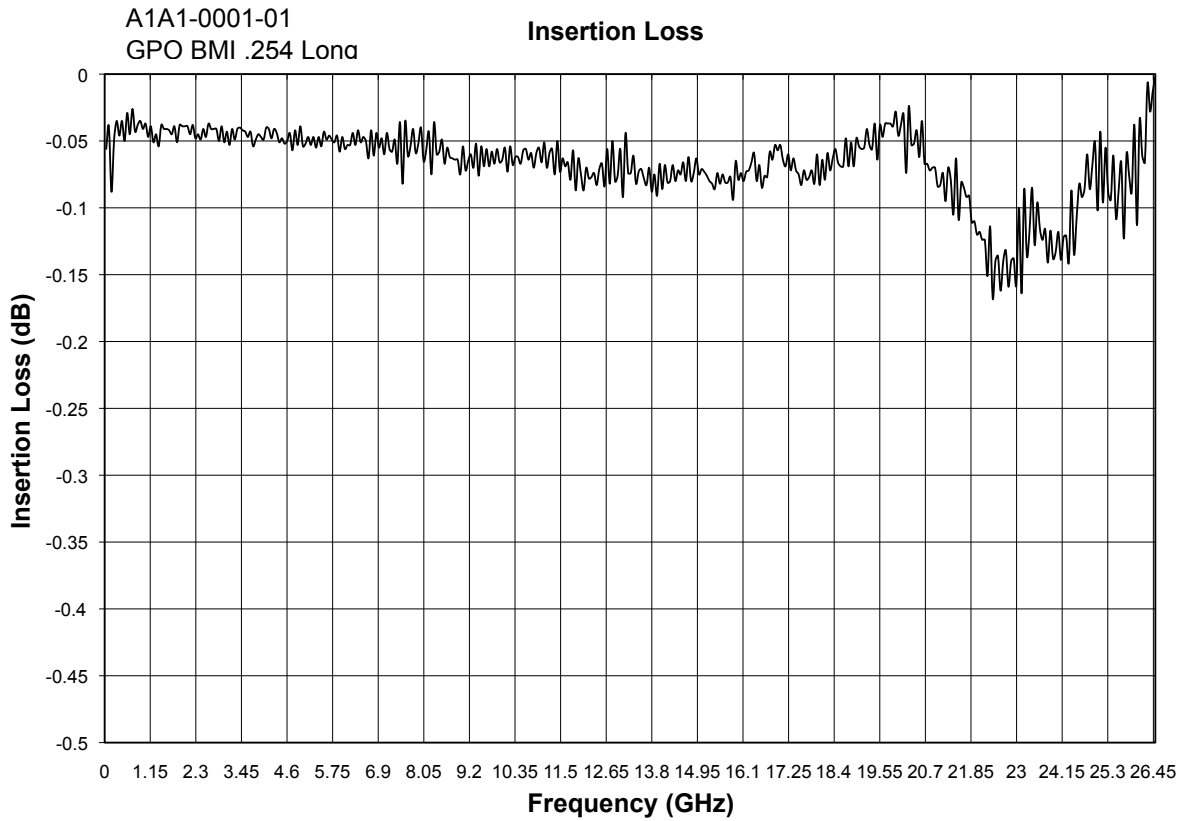

Figure 7B - GPO BMI Insertion Loss Performance



Figure 8 - GPO Cable Connector 0119-925-1

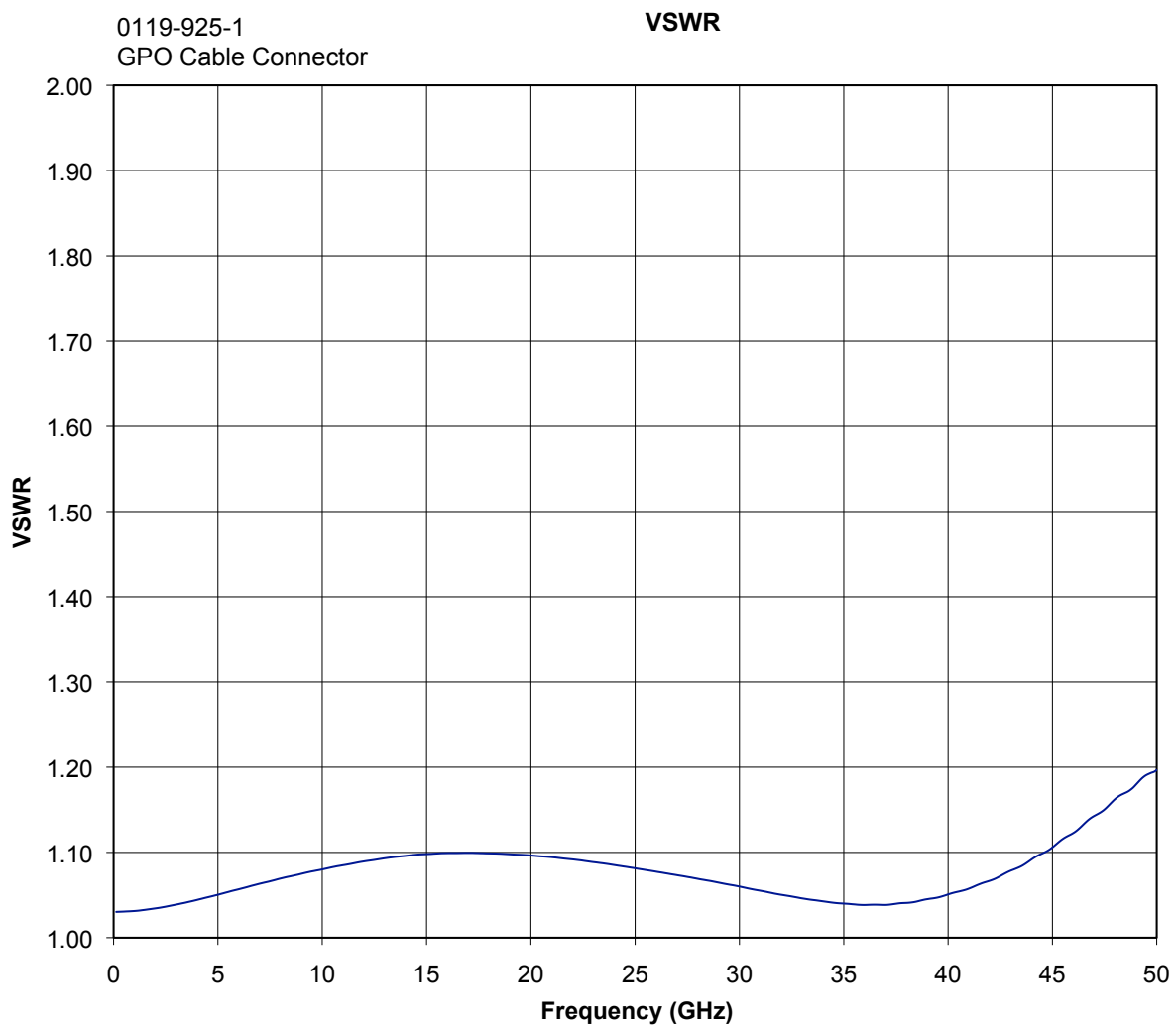

Figure 8A - GPO Cable Connector VSWR Performance

3.0 GPPO

3.1 GPPO Detents – Full and Smooth Bore

Table 3 shows the available GPPO detents, typical engage / disengage forces, and mating cycles.

Table 3 - GPPO Detent Forces and Mating Cycles

Detent	GPPO		
	Engage*	Disengage*	Cycles (Min)
Full	4.5	6.5	100
Smooth Bore	2.5	1.5	500

* The engage / disengage force values (shown in pounds) are typical and based upon actual data.

3.2 GPPO Axial Misalignment

Figure 9 shows the GPPO VSWR electrical performance versus frequency and axial misalignment.

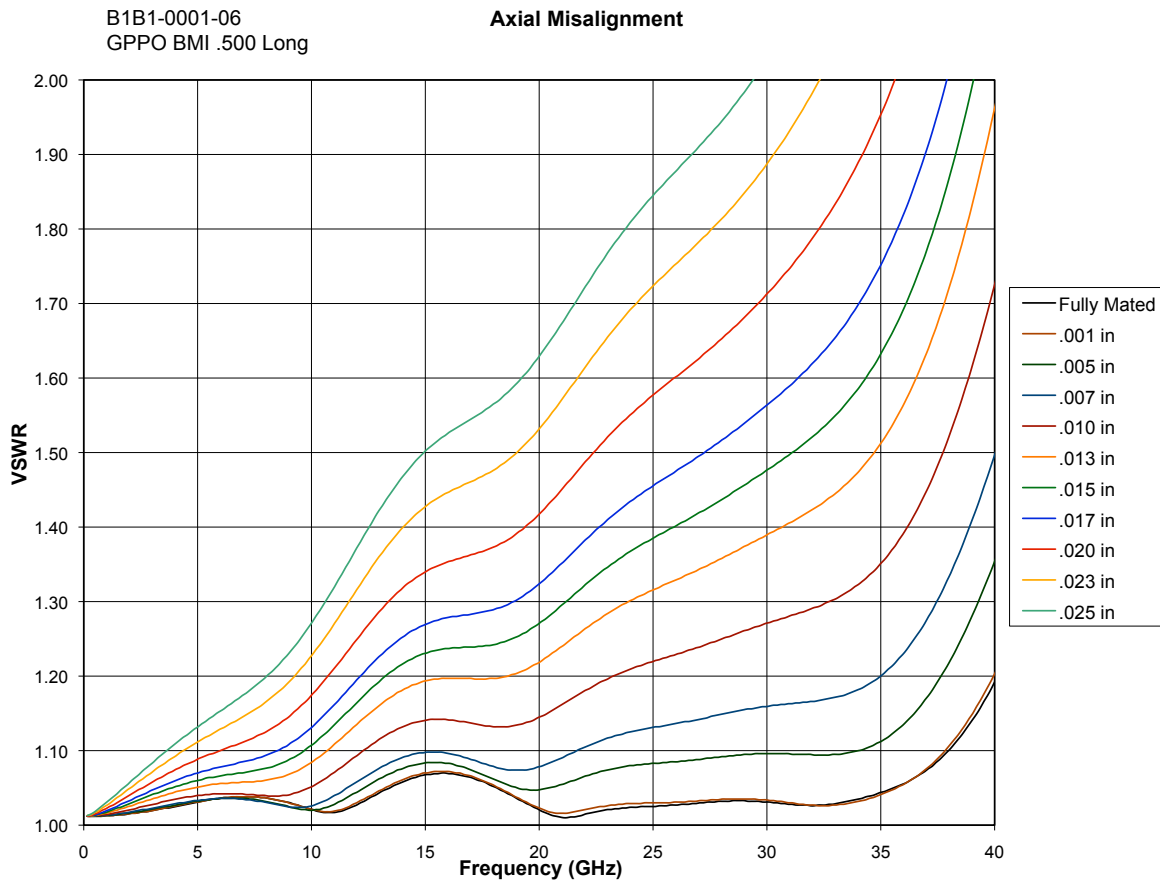

Figure 9 - GPPO Axial Misalignment Performance

3.3 GPPO Radial Misalignment

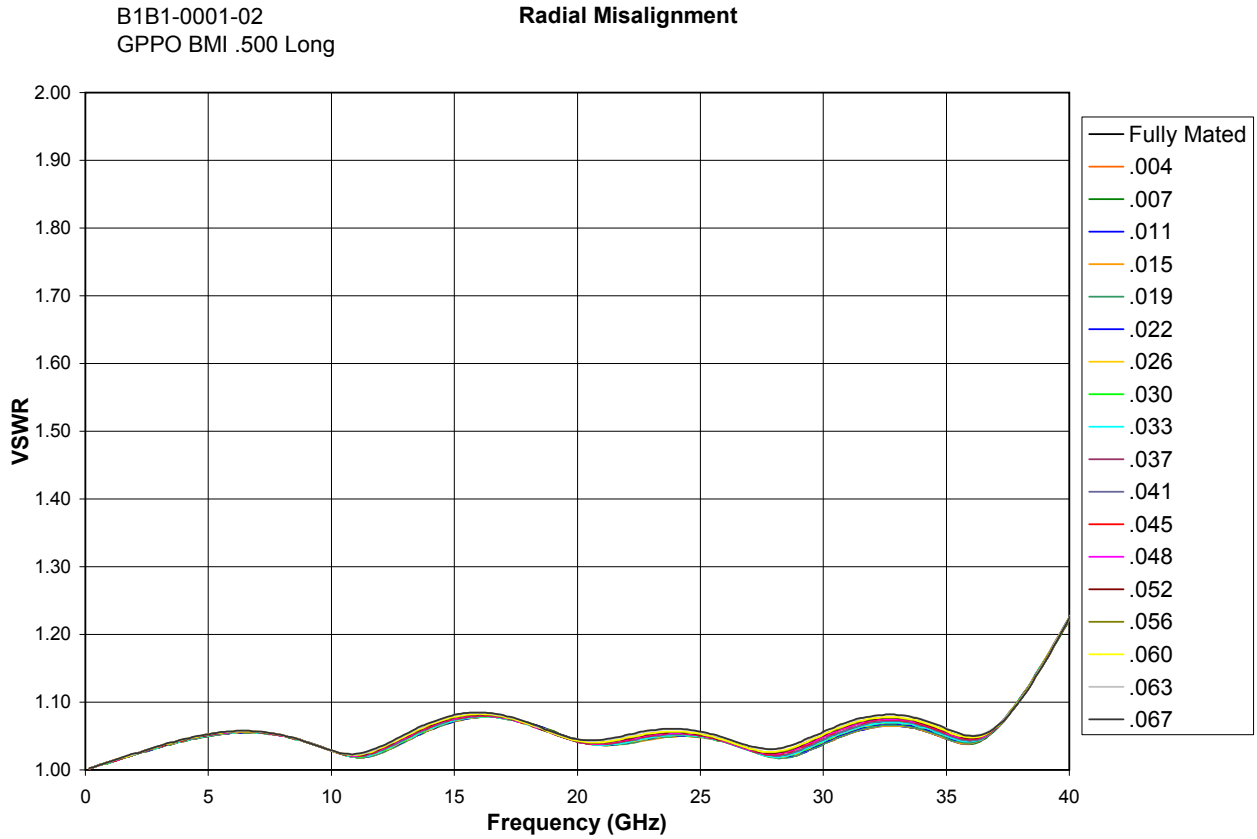

Figure 10 - GPPO Radial Misalignment Performance

3.4 GPPO VSWR and Insertion Loss



Figure 11 - GPPO BMI B1B1-0001-01

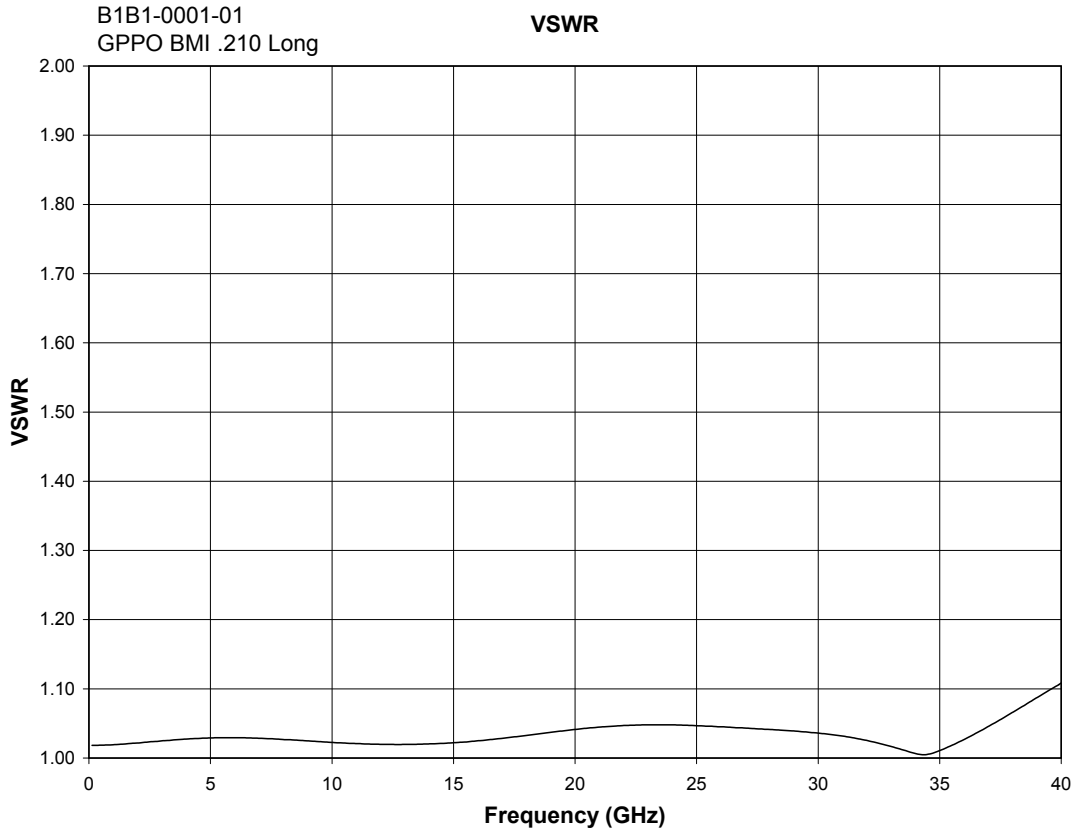

Figure 11A - GPPO BMI VSWR Performance

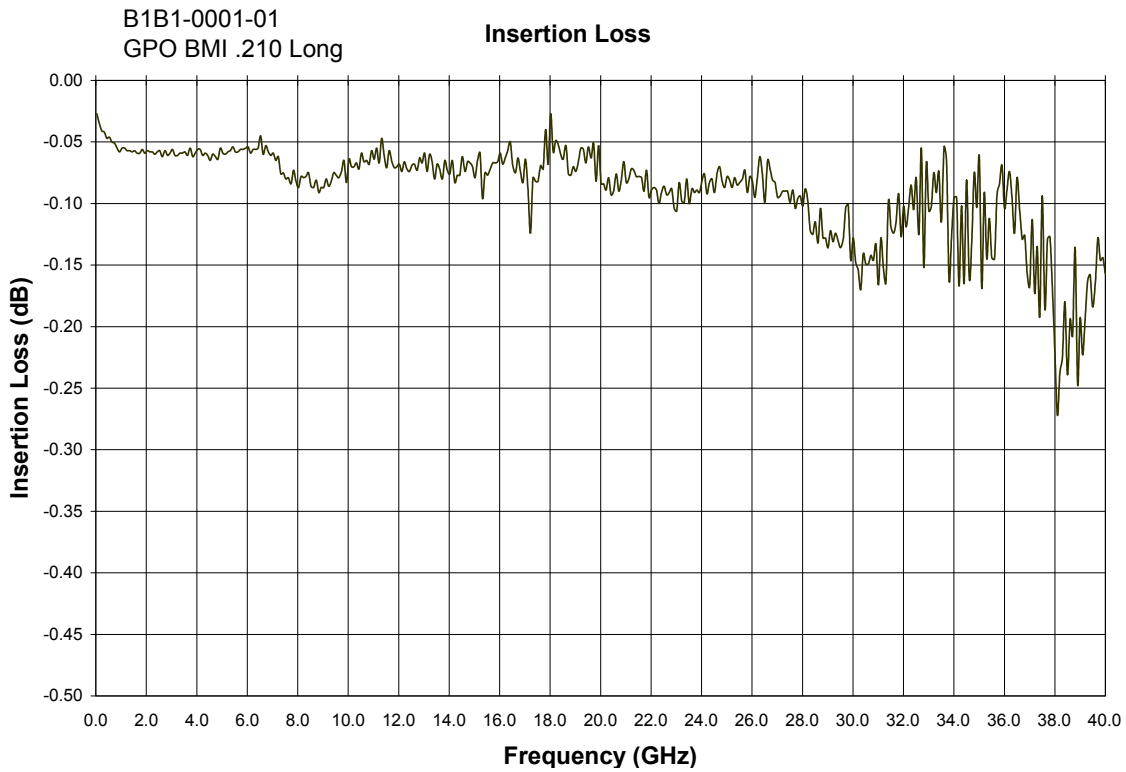

Figure 11B - GPPO BMI Insertion Loss Performance



Figure 12 - GPPO Cable Connector B014-D11-01

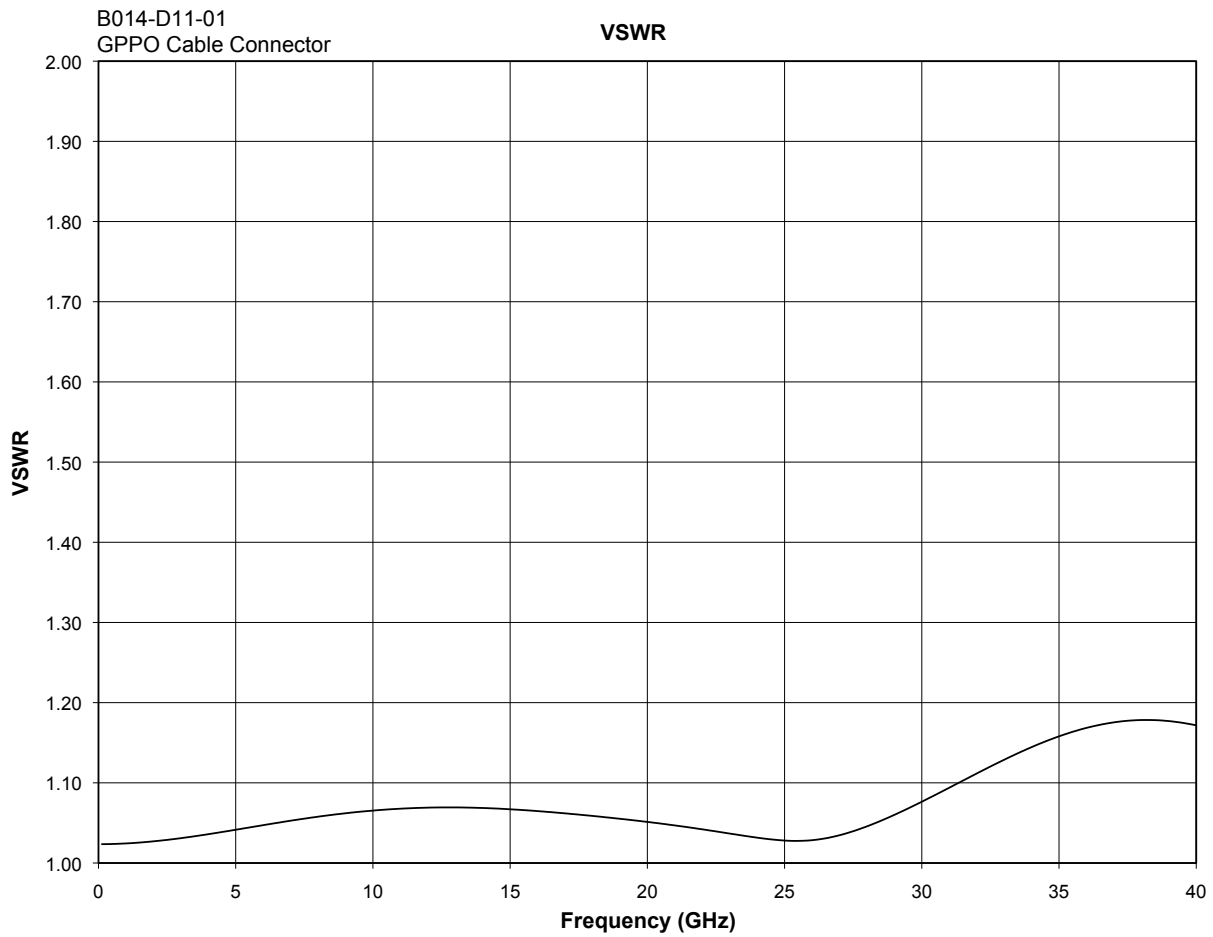

Figure 12A - GPPO Cable Connector VSWR Performance

4.0 G3PO

4.1 G3PO Detents – Full and Smooth Bore

Table 4 shows the available G3PO detents, typical engage / disengage forces, and mating cycles.

Table 4 – G3PO Detent Forces and Mating Cycles

Detent	G3PO		
	Engage*	Disengage*	Cycles (Min)
Full	2.5	4.5	100
Smooth Bore	1.2	1.0	500

* The engage / disengage force values (shown in pounds) are typical and based upon actual data.

4.2 G3PO Axial Misalignment

Figure 13 shows the G3PO VSWR electrical performance versus frequency and axial misalignment.

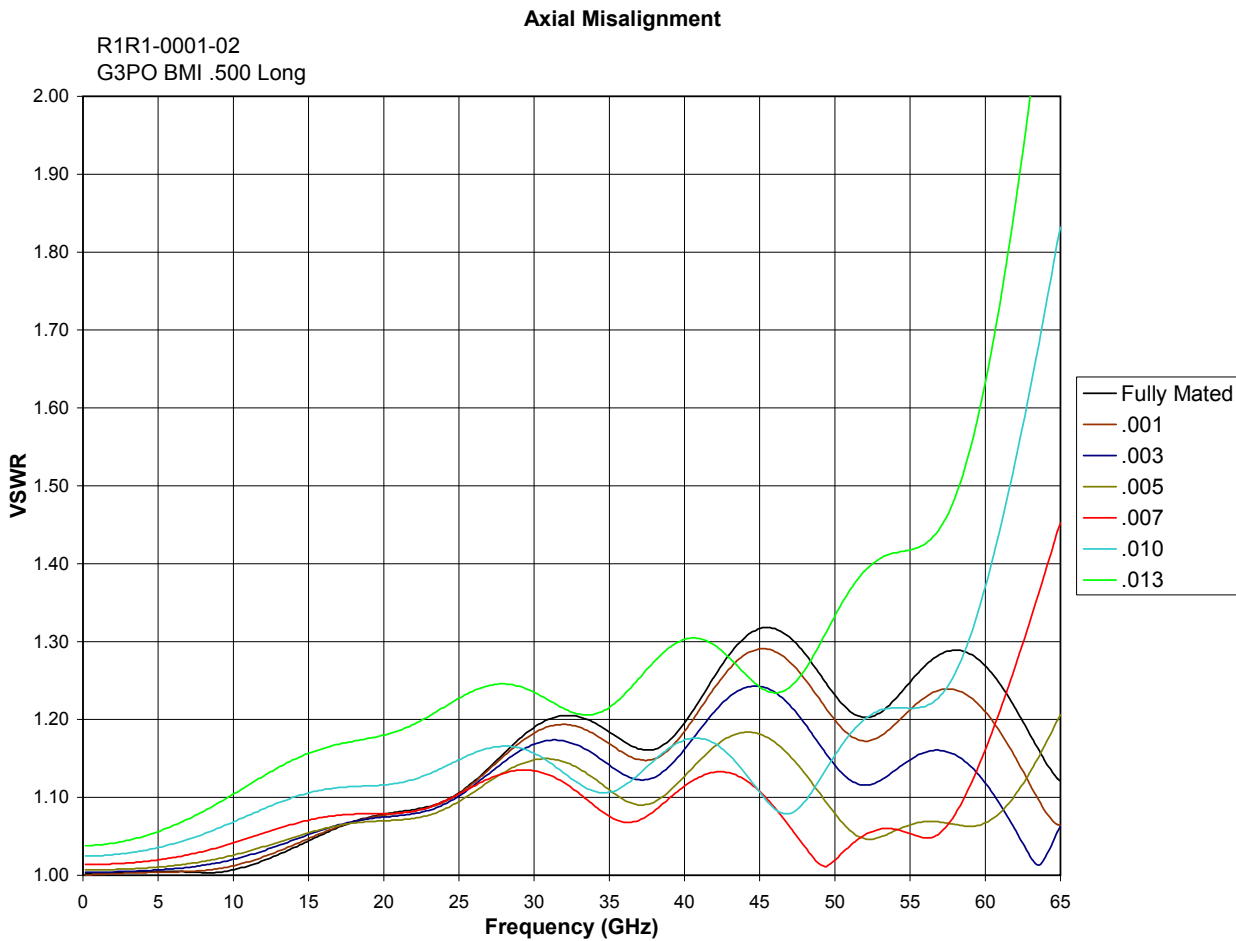

Figure 13 – G3PO Axial Misalignment Performance

4.3 G3PO Radial Misalignment

Figure 14 shows the G3PO VSWR electrical performance versus frequency and radial misalignment.

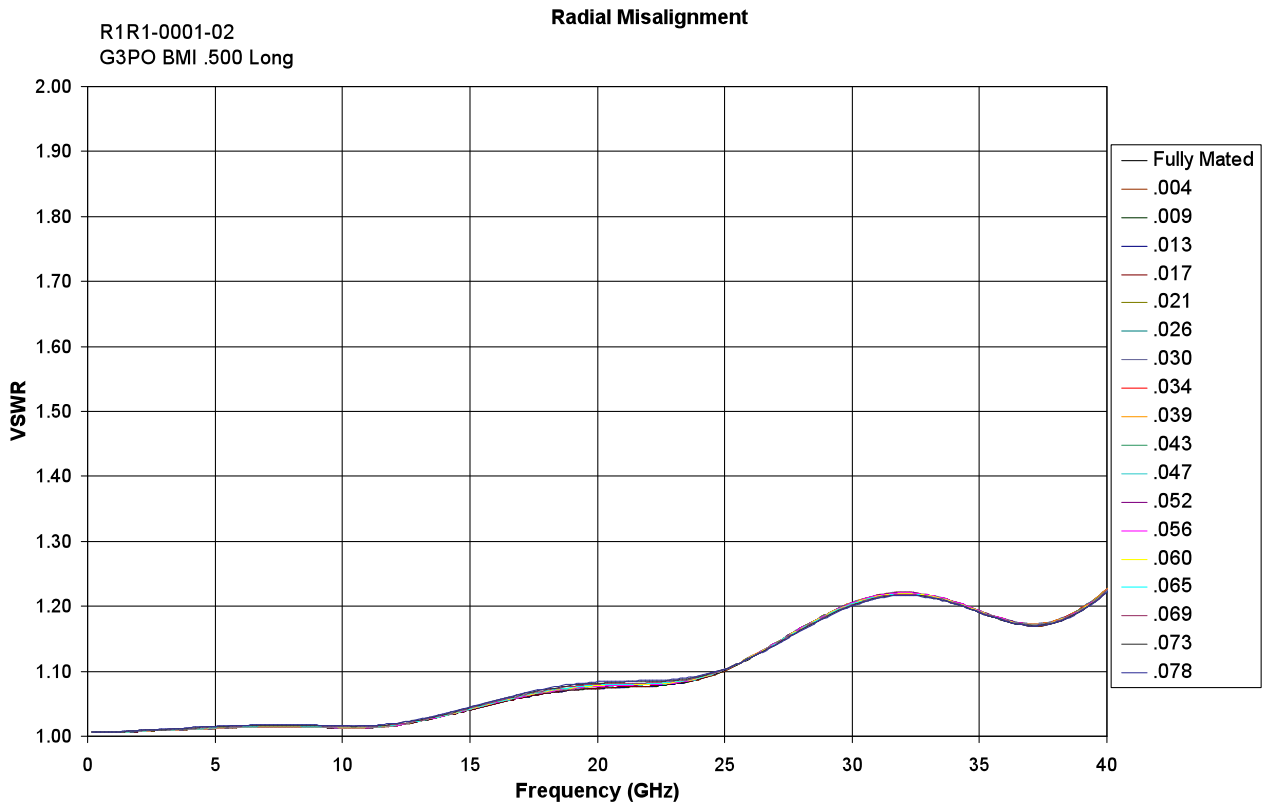

Figure 14 – G3PO Radial Misalignment Performance

4.4 G3PO VSWR and Insertion Loss

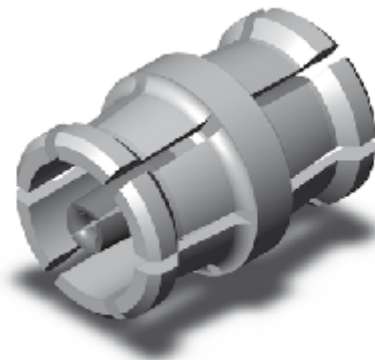

Figure 15 – G3PO BMI R1R1-0001-01

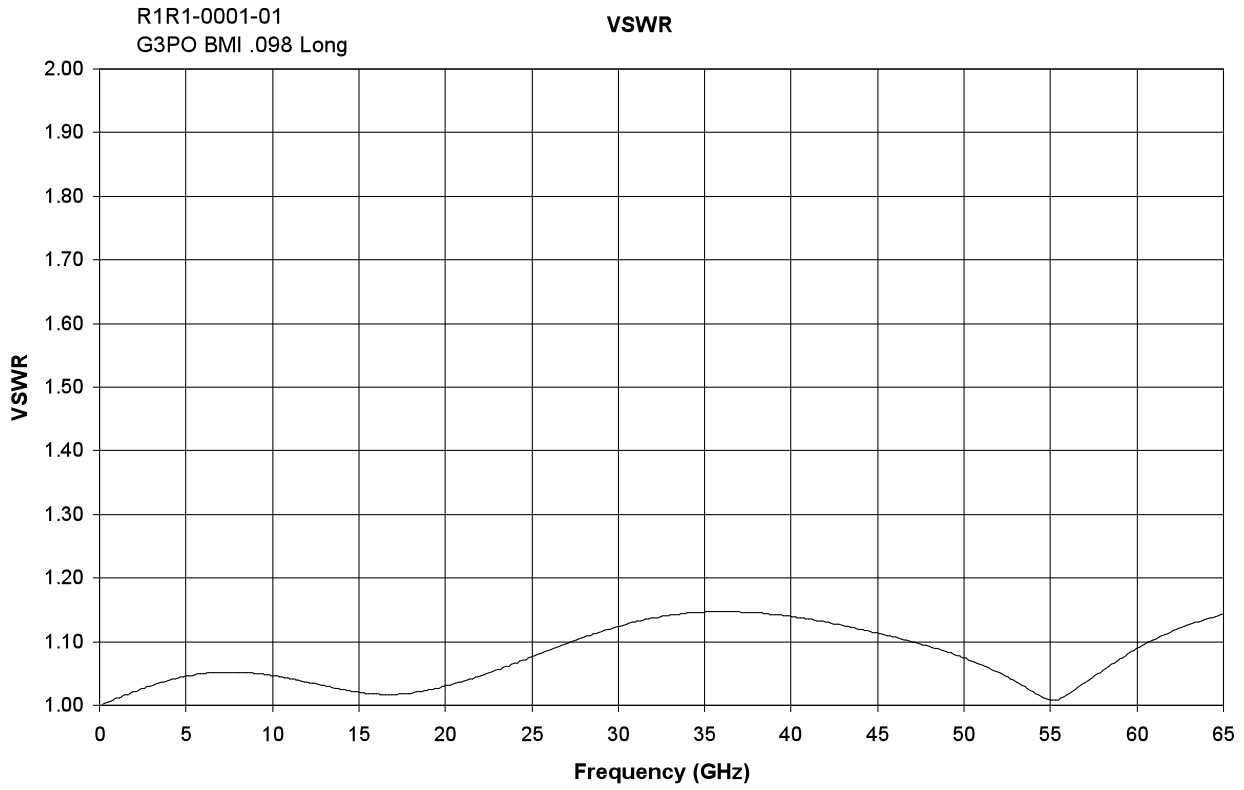

Figure 15A – G3PO BMI VSWR Performance

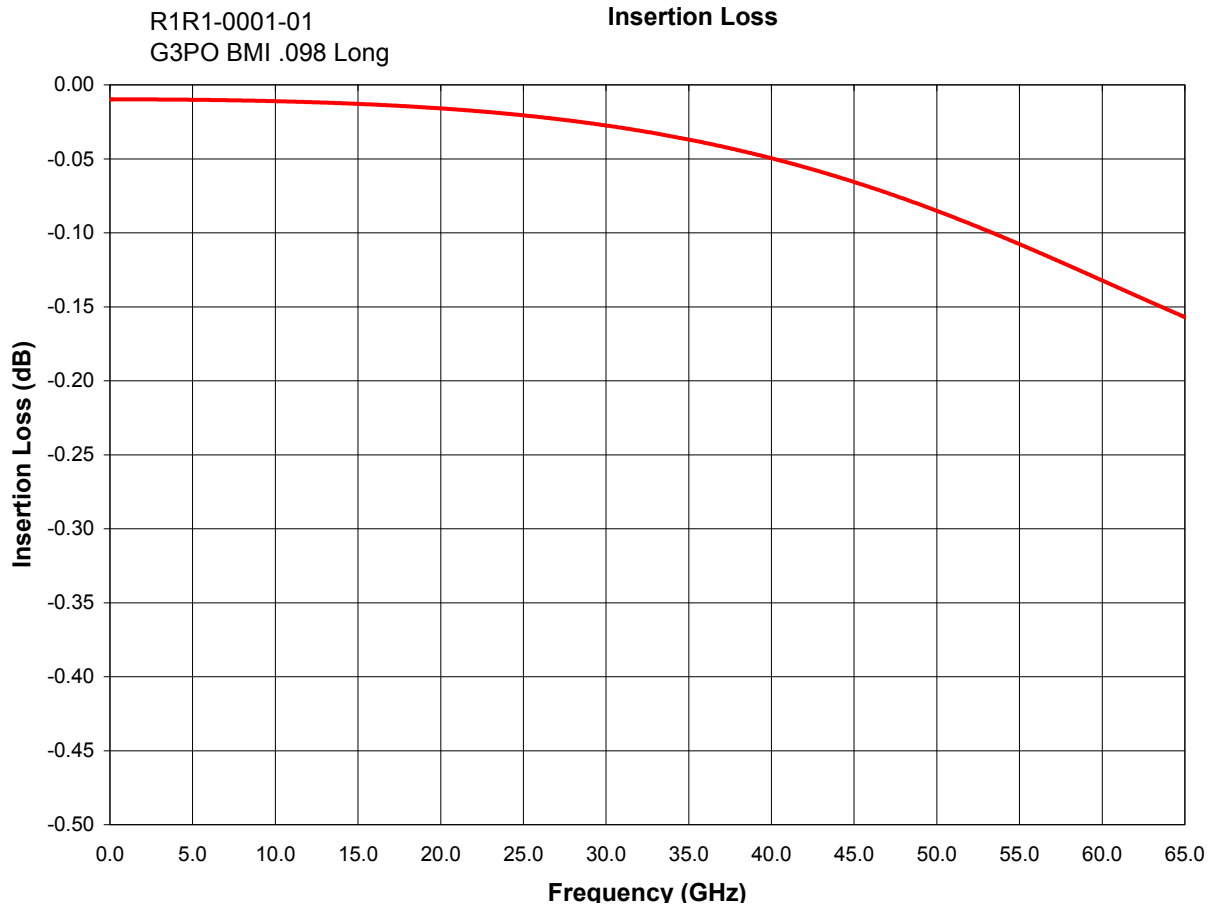

Figure 15B – G3PO BMI Insertion Loss Performance



Figure 16 – G3PO Cable Connector R014-B11-01

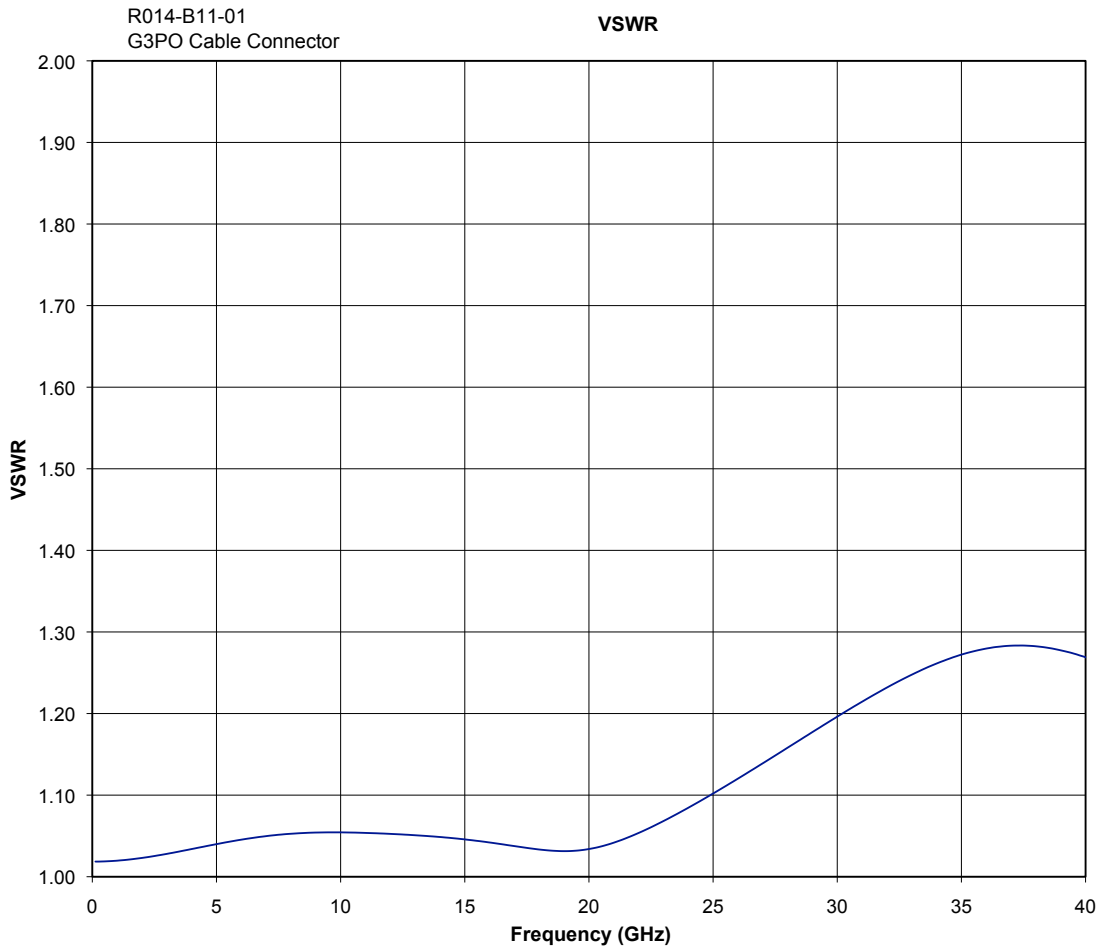

Figure 16A – G3PO Cable Connector VSWR Performance

5.0 G4PO

5.1 G4PO Detents – Full and Smooth Bore

Table 5 shows the available G4PO detents, typical engage / disengage forces, and mating cycles.

Table 5 – G4PO Detent Forces and Mating Cycles

Detent	G4PO		
	Engage*	Disengage*	Cycles (Min)
Full	.65	2.2	100
Smooth Bore	.20	.15	500

* The engage / disengage force values (shown in pounds) are typical and based upon actual data.

5.2 G4PO VSWR



Figure 17 – G4PO BMI S1S1-0001-01

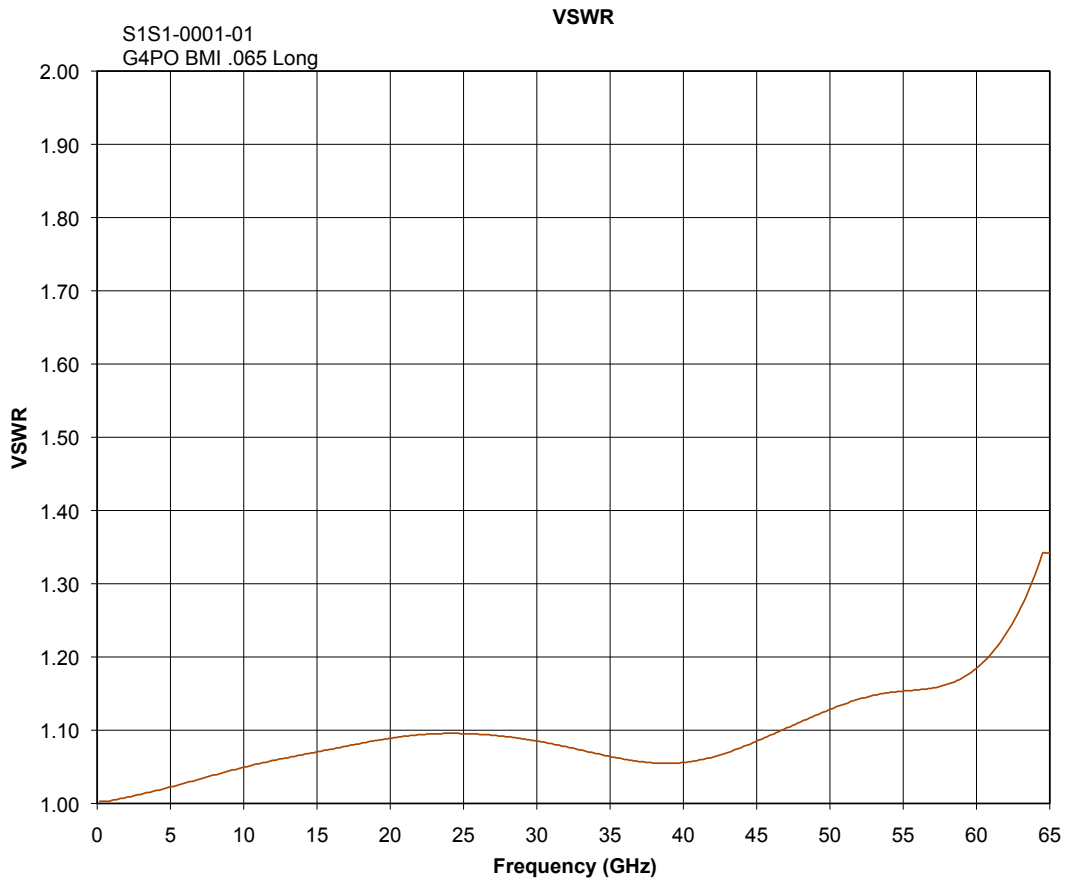

Figure 17A – G4PO BMI VSWR Performance

6.0 SGMS

6.1 SGMS Detents – Full and Smooth Bore

Table 6 shows the available SGMS detents, typical engage / disengage forces, and mating cycles.

Table 6 – SGMS Detent Forces and Mating Cycles

Detent	SGMS		
	Engage*	Disengage*	Cycles (Min)
Limited	4.5	6.0	100
Smooth Bore	3.0	1.5	5000

* The engage / disengage force values (shown in pounds) are typical and based upon actual data.

6.2 SGMS Axial Misalignment

Figure 18 shows the SGMS VSWR electrical performance versus frequency and axial misalignment.

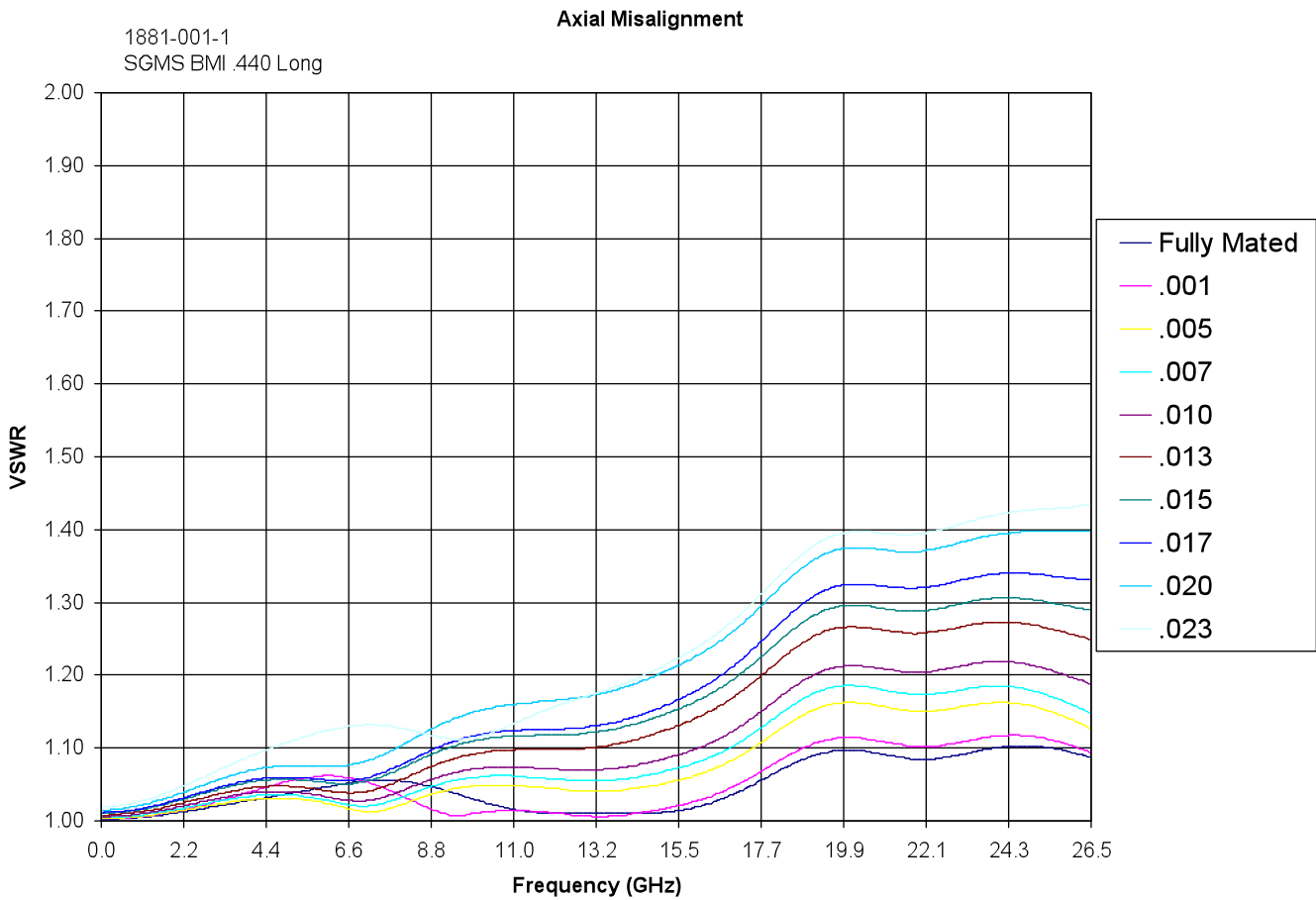

Figure 18 – SGMS Axial Misalignment Performance

6.3 SGMS Radial Misalignment

Figure 19 shows the SGMS VSWR electrical performance versus frequency and radial misalignment.

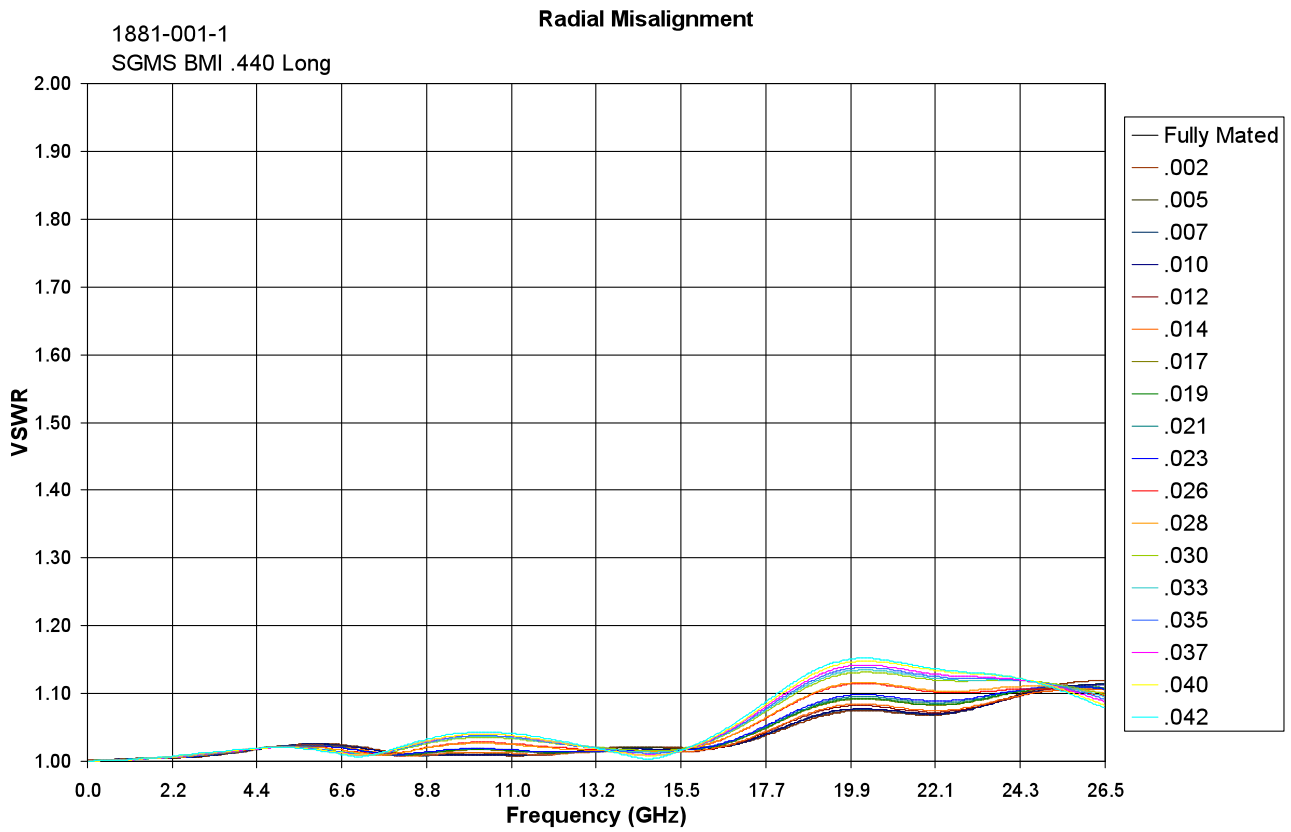

Figure 19 – SGMS Radial Misalignment Performance

6.4 SGMS VSWR and Insertion Loss



Figure 20 – SGMS BMI 1881-001-1

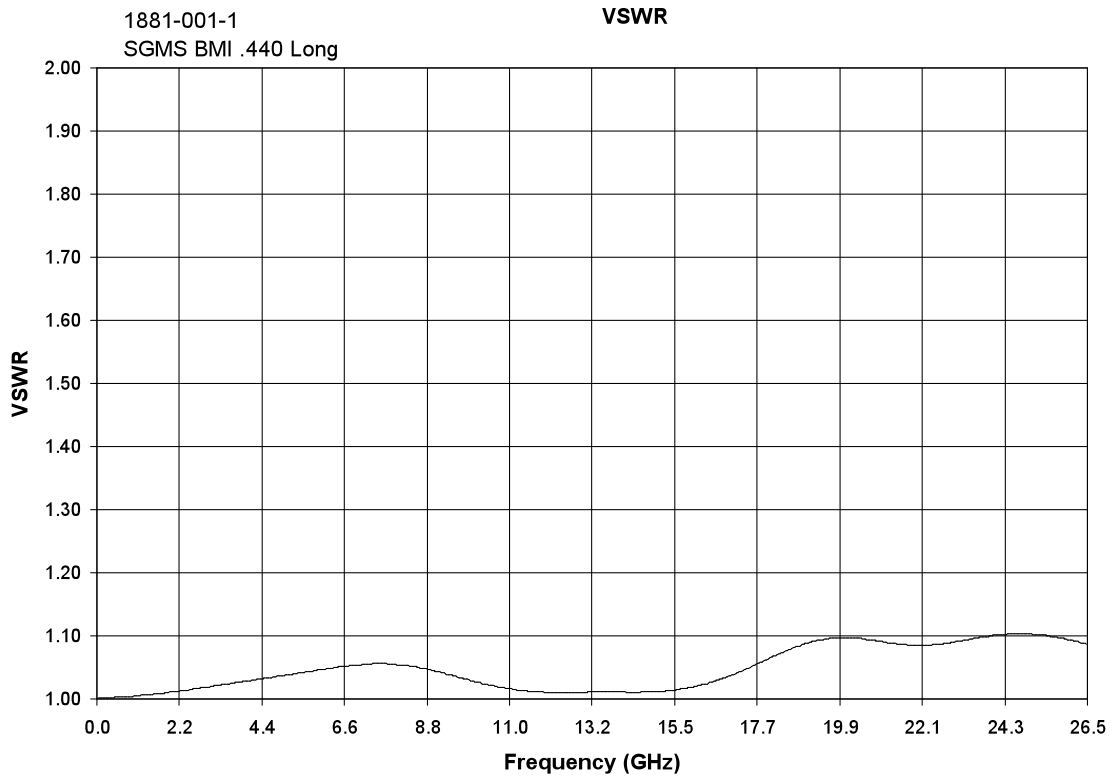

Figure 20A – SGMS BMI VSWR Performance

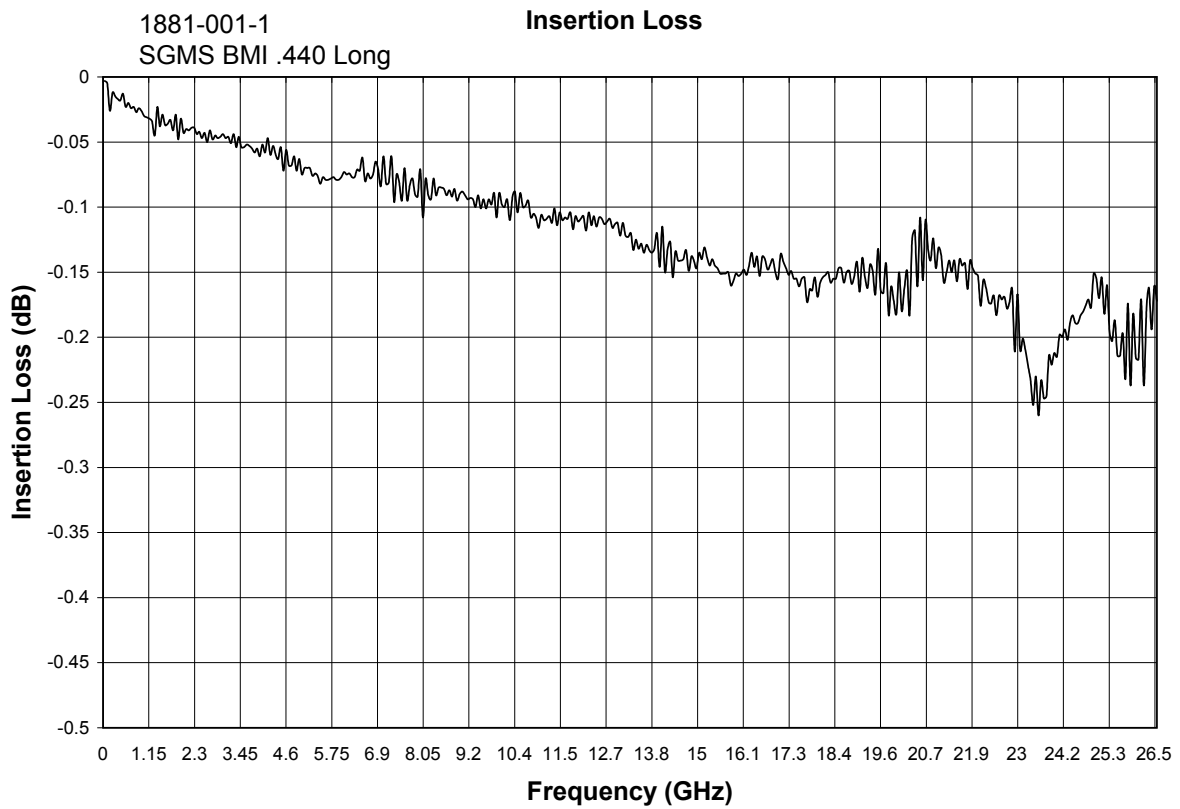

Figure 20B – SGMS BMI Insertion Loss Performance

7.0 Electrical – GPO, GPPO, G3PO, G4PO, and SGMS

7.1 General Electrical Specifications

Table 7 – GPO, GPPO, G3PO, G4PO, and SGMS General Electrical Specifications

Parameter	GPO	GPPO	G3PO	G4PO	SGMS
Dielectric Withstanding Voltage (DWV)	500 Vrms	325 Vrms	250 Vrms	250 Vrms	1500 Vrms
Insulation Resistance (IR)	5000 MOhms @ 500 VDC	5000 MOhms @ 500 VDC	3500 MOhms @ 100 VDC	3500 MOhms @ 100 VDC	5000 MOhms @ 500 VDC
RF High Pot. @ 5 MHz	325 Vrms	200 Vrms	150 Vrms	150 Vrms	500 Vrms
Corona Level @ 70,000 ft	190 Vrms	125 Vrms	100 Vrms	100 Vrms	250 Vrms
Center Conductor Contact Resistance	6.0 mOhms max	6.0 mOhms max	6.0 mOhms max	6.0 mOhms max	6.0 mOhms max

7.2 Average Power Handling

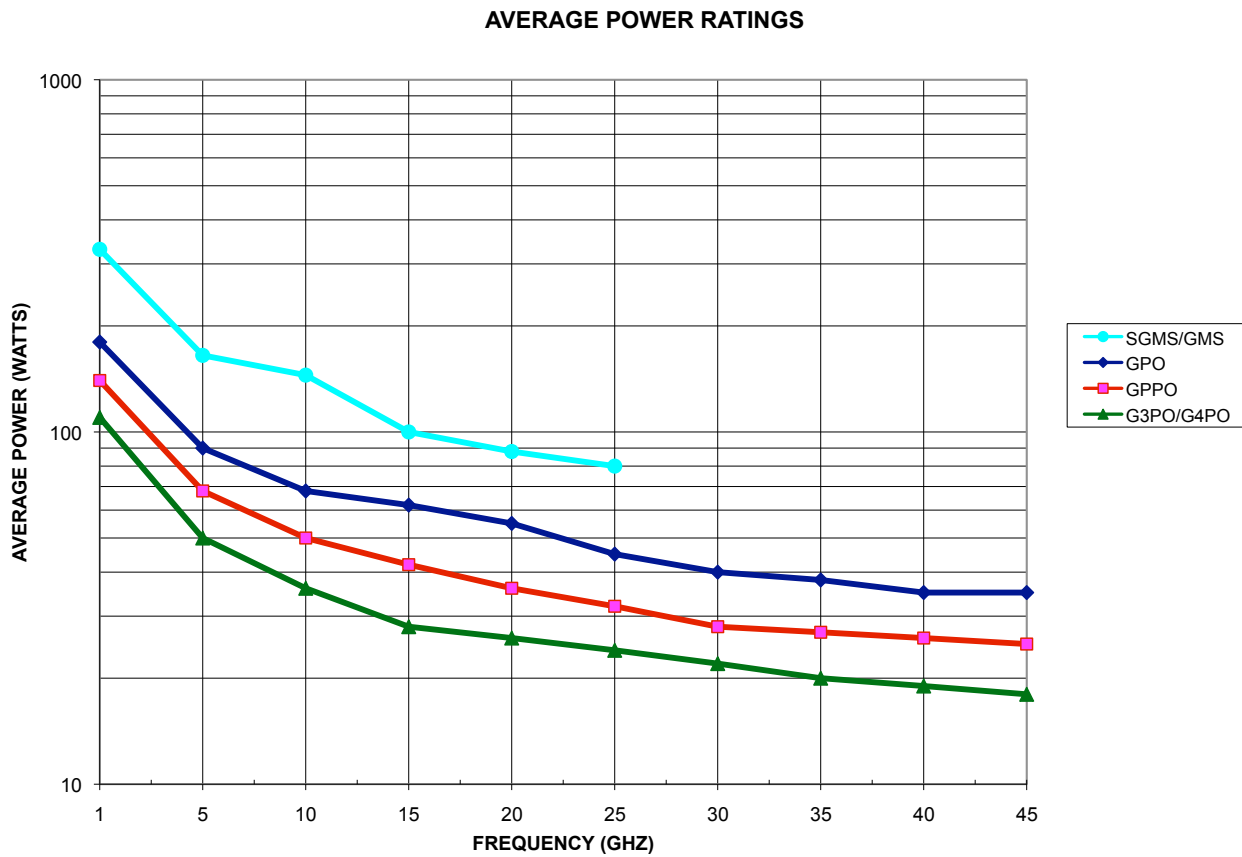

Figure 21 - GPO, GPPO, G3PO, G4PO, and SGMS Average Power Handling

7.3 Temperature and Altitude De-rating

Table 8 – Typical Temperature and Altitude De-rating Factors

TEMP DEG C	DERATING FACTOR	ALTITUDE X 1000'	DERATING FACTOR
0	1.2	0	1.0
40	1.0	20	0.8
80	0.8	30	0.7
120	0.6	40	0.6
160	0.4	50	0.5
200	0.2	60	0.4
240	0.05	70	0.3

7.4 VSWR De-rating

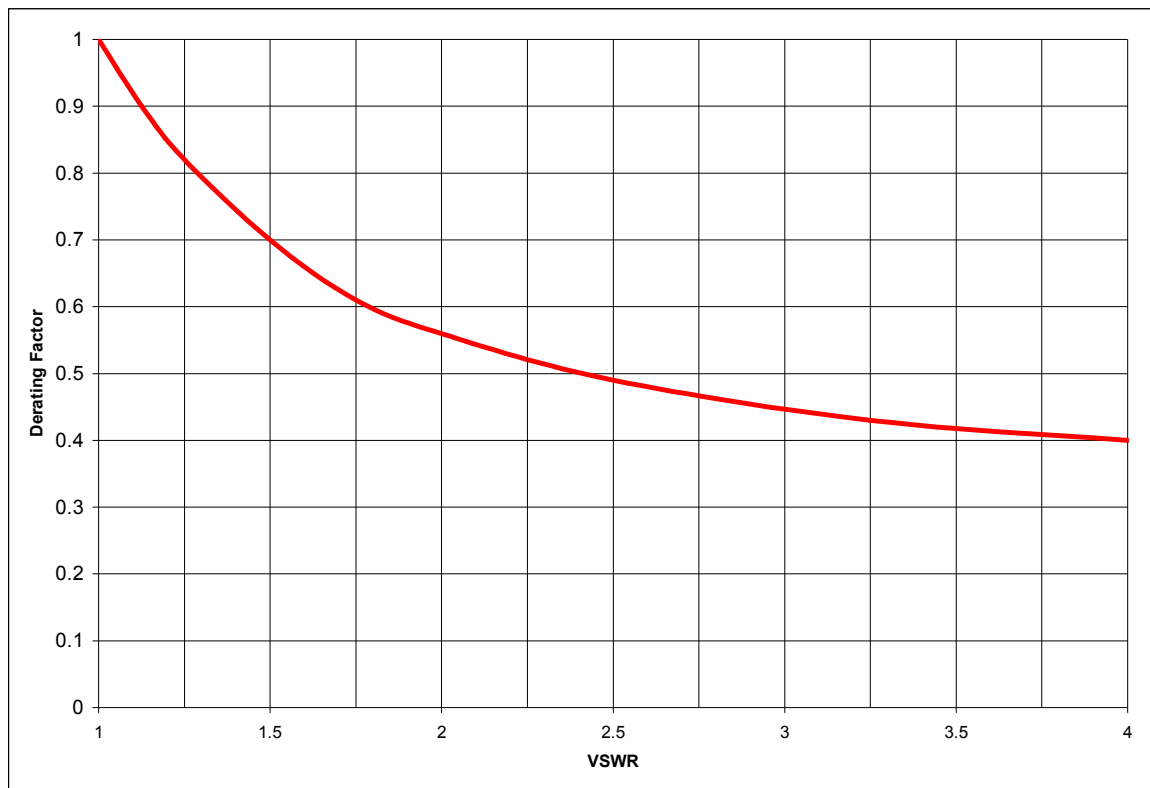

Figure 22 – Typical VSWR De-rating Factors

8.0 Board-to-Board Tolerance Analysis

8.1 GPO Tolerance Analysis

Figure 23 shows a typical GPO Board-to-Board tolerance analysis using a surface mount configuration. The BMI Length and associated Gap are dependent on the **Board-to-Board spacing, Shroud Reference Plane (R/P), and Solder Thickness.**

Determine the Shroud R/P to Shroud R/P spacing as follows:

.4545 ± .005	Board-to-Board
-.091 ± .003	Shroud R/P
-.091 ± .003	Shroud R/P
-.002 ± .001	Solder Thickness
-.002 ± .001	Solder Thickness
<hr/>	
.2685 ± .013	Shroud R/P to R/P

The **minimum Shroud R/P to R/P** spacing is therefore $.2685 - .013 = .2555$. This dimension is also the **maximum BMI Length**. This ensures that the BMI doesn't bottom out between the Shroud Reference Planes. The nominal BMI Length is the **minimum R/P to R/P** spacing minus the BMI Length tolerance (.0015). The **nominal BMI Length** is therefore $.2555 - .0015 = .254$.

Next, determine the Gap between the Smooth Bore Shroud R/P and the BMI as follows:

.2685 ± .013	Shroud R/P to Shroud R/P
-.254 ± .0015	BMI Length
<hr/>	
.0145 ± .0145	Gap

The tolerance analysis shows that the BMI can be flush ($.0145 - .0145$) to $.029$ ($.0145 + .0145$) away from the Smooth Bore Shroud R/P. The Gap tolerance should be minimized whenever possible to ensure optimal electrical performance.

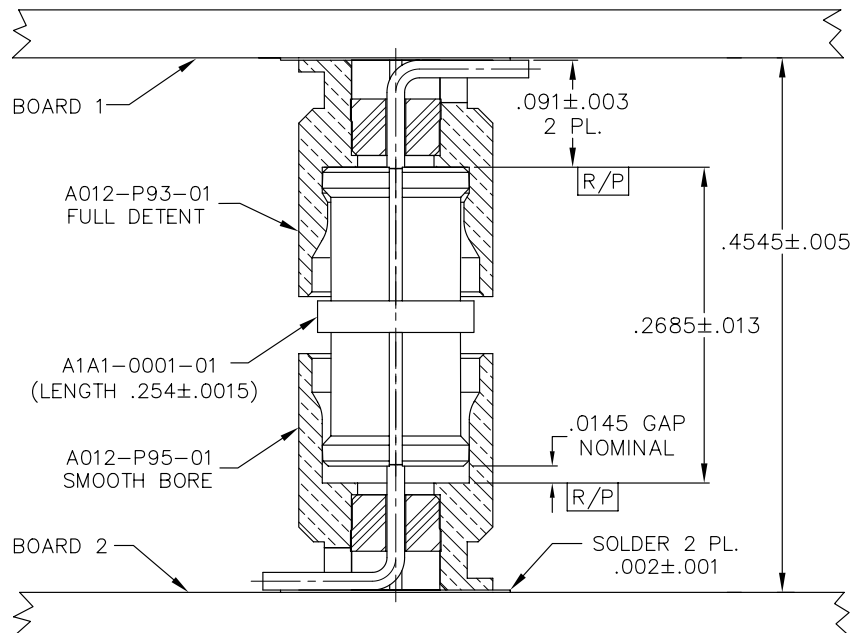

Figure 23 – GPO Board-to-Board Tolerance Analysis

8.2 GPO Minimum Tolerance Analysis

Figure 24 shows the minimum GPO Board-to-Board tolerance analysis using a surface mount configuration. The BMI Length and associated Gap are dependent on the **Board-to-Board spacing, Shroud Reference Plane (R/P), and Solder Thickness.**

Determine the Shroud R/P to Shroud R/P spacing as follows:

.258 ± .005	Board-to-Board
-.010 ± .001	Shroud R/P
-.010 ± .001	Shroud R/P
-.002 ± .001	Solder Thickness
-.002 ± .001	Solder Thickness
<hr/>	
.234 ± .009	Shroud R/P to R/P

The **minimum Shroud R/P to R/P** spacing is therefore $.234 - .009 = .225$. This dimension is also the **maximum BMI Length**. This ensures that the BMI doesn't bottom out between the Shroud Reference Planes. The nominal BMI Length is the **minimum R/P to R/P** spacing minus the BMI Length tolerance (.001). The nominal BMI Length is therefore $.225 - .001 = .224$. Next, determine the Gap between the Smooth Bore Shroud R/P and the BMI as follows:

.234 ± .009	Shroud R/P to Shroud R/P
-.224 ± .001	BMI Length
<hr/>	
.010 ± .010	Gap

The tolerance analysis shows that the BMI can be flush (.010 - .010) to .020 (.010 + .010) away from the Smooth Bore Shroud R/P. The Gap tolerance should be minimized whenever possible to ensure optimal electrical performance.

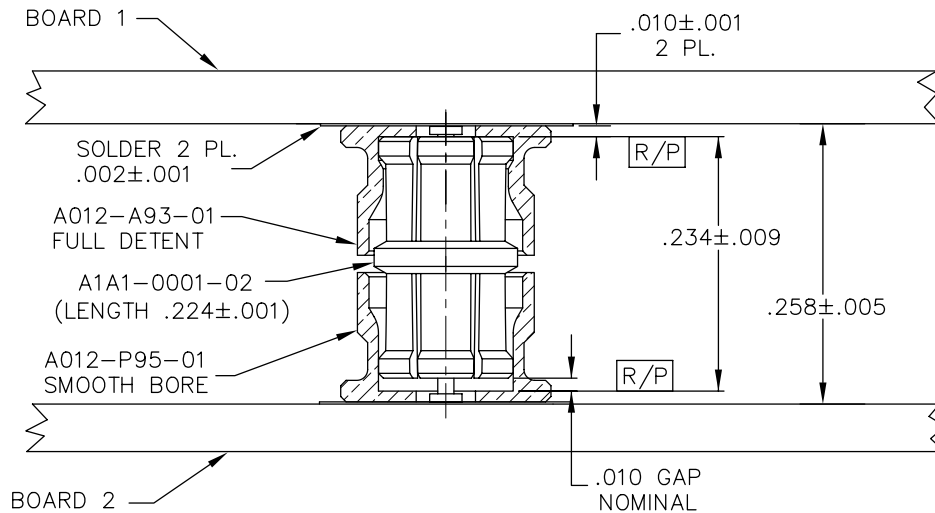

Figure 24 – GPO Minimum Board-to-Board Tolerance Analysis

8.3 GPPO Tolerance Analysis

Figure 25 shows a typical GPPO Board-to-Board tolerance analysis using a surface mount configuration. The BMI Length and associated Gap are dependent on the **Board-to-Board spacing, Shroud Reference Plane (R/P), and Solder Thickness.**

Determine the Shroud R/P to Shroud R/P spacing as follows:

.360 ± .005	Board-to-Board
-.067 ± .002	Shroud R/P
-.067 ± .002	Shroud R/P
-.002 ± .001	Solder Thickness
-.002 ± .001	Solder Thickness
<hr/>	
.222 ± .011	Shroud R/P to R/P

The minimum Shroud R/P to R/P spacing is therefore $.222 - .011 = .211$. This dimension is also the maximum BMI Length. This ensures that the BMI doesn't bottom out between the Shroud Reference Planes. The nominal BMI Length is the minimum R/P to R/P spacing minus the BMI Length tolerance (.001). The **nominal BMI Length** is therefore $.211 - .001 = .210$.

Next, determine the Gap between the Smooth Bore Shroud R/P and the BMI as follows:

.222 ± .011	Shroud R/P to Shroud R/P
-.210 ± .001	BMI Length
<hr/>	
.012 ± .012	Gap

The tolerance analysis shows that the BMI can be flush ($.012 - .012$) to $.024$ ($.012 + .012$) away from the Smooth Bore Shroud R/P. The Gap tolerance should be minimized whenever possible to ensure optimal electrical performance.

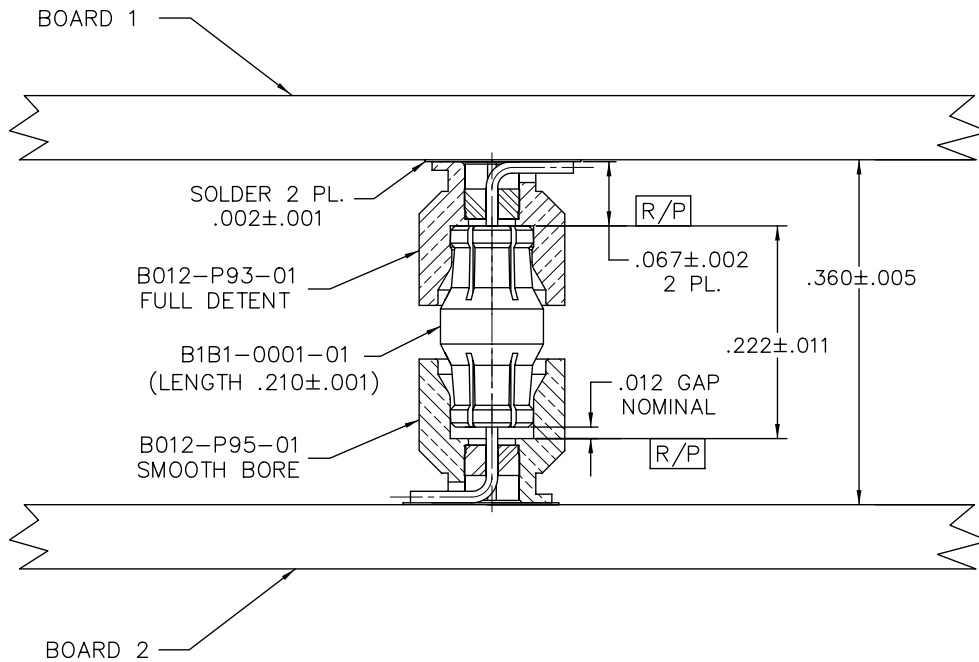

Figure 25 – GPPO Board-to-Board Tolerance Analysis

8.4 GPPO Minimum Tolerance Analysis

Figure 26 shows the minimum GPPO Board-to-Board tolerance analysis using a surface mount configuration. The BMI Length and associated Gap are dependent on the **Board-to-Board spacing, Shroud Reference Plane (R/P), and Solder Thickness.**

Determine the Shroud R/P to Shroud R/P spacing as follows:

.196 ± .005	Board-to-Board
-0.008 ± .001	Shroud R/P
-0.008 ± .001	Shroud R/P
-0.002 ± .001	Solder Thickness
-0.002 ± .001	Solder Thickness
<hr/>	
.176 ± .009	Shroud R/P to R/P

The **minimum Shroud R/P to R/P** spacing is therefore $.176 - .009 = .167$. This dimension is also the **maximum BMI Length**. This ensures that the BMI doesn't bottom out between the Shroud Reference Planes. The nominal BMI Length is the **minimum R/P to R/P** spacing minus the BMI Length tolerance (.001). The **nominal BMI Length** is therefore $.167 - .001 = .166$.

Next, determine the Gap between the Smooth Bore Shroud R/P and the BMI as follows:

.176 ± .009	Shroud R/P to Shroud R/P
-0.166 ± .001	BMI Length
<hr/>	
.010 ± .010	Gap

The tolerance analysis shows that the BMI can be flush (.010 - .010) to .020 (.010 + .010) away from the Smooth Bore Shroud R/P. The Gap tolerance should be minimized whenever possible to ensure optimal electrical performance.

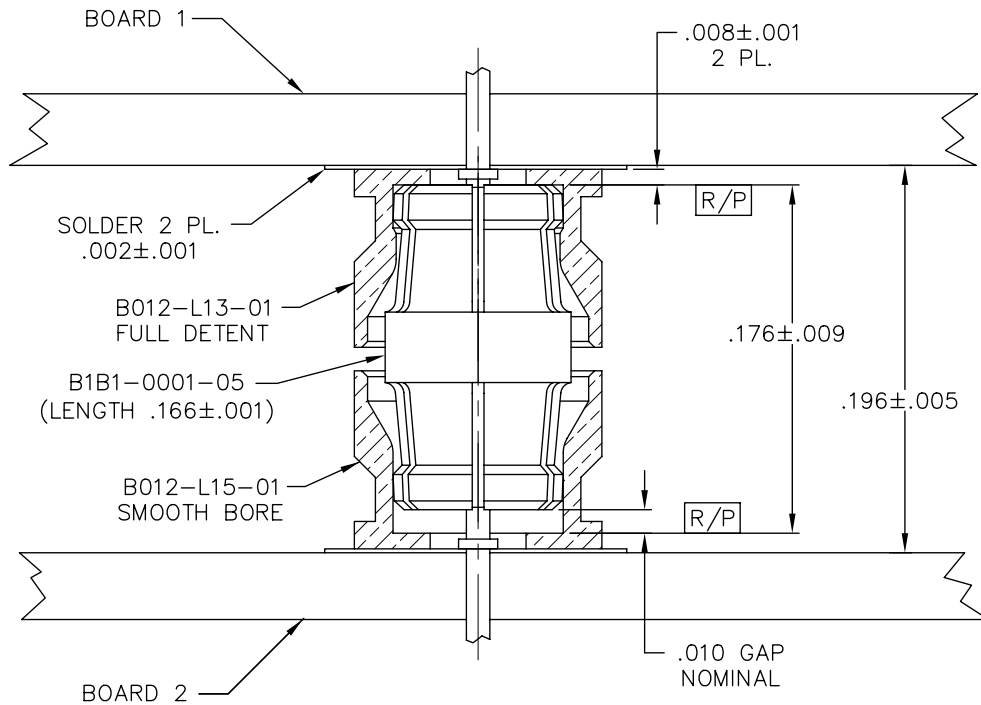

Figure 26 – GPPO Minimum Board-to-Board Tolerance Analysis

8.5 G3PO Tolerance Analysis

Figure 27 shows a typical G3PO Board-to-Board tolerance analysis using a surface mount configuration. The BMI Length and associated Gap are dependent on the **Board-to-Board spacing, Shroud Reference Plane (R/P), and Solder Thickness.**

Determine the Shroud R/P to Shroud R/P spacing as follows:

.1485 ± .002	Board-to-Board
-.020 ± .001	Shroud R/P
-.020 ± .001	Shroud R/P
-.002 ± .001	Solder Thickness
-.002 ± .001	Solder Thickness
<hr/>	
.1045 ± .006	Shroud R/P to R/P

The **minimum Shroud R/P to R/P** spacing is therefore $.1045 - .006 = .0985$. This dimension is also the **maximum BMI Length**. This ensures that the BMI doesn't bottom out between the Shroud Reference Planes. The nominal BMI Length is the **minimum R/P to R/P** spacing minus the BMI Length tolerance (.0005). The **nominal BMI Length** is therefore $.0985 - .0005 = .098$.

Next, determine the Gap between the Smooth Bore Shroud R/P and the BMI as follows:

.1045 ± .006	Shroud R/P to Shroud R/P
-.098 ± .0005	BMI Length
<hr/>	
.0065 ± .0065	Gap

The tolerance analysis shows that the BMI can be flush (.0065 - .0065) to .013 (.0065 + .0065) away from the Smooth Bore Shroud R/P. The Gap tolerance should be minimized whenever possible to ensure optimal electrical performance.

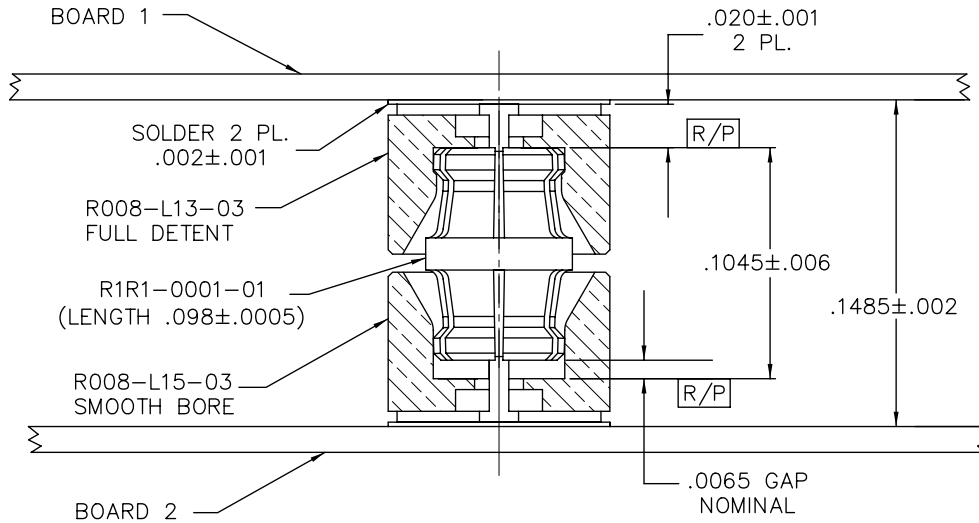

Figure 27 – G3PO Board-to-Board Tolerance Analysis

Please contact Applications Engineering to configure the G3PO minimum board-to-board spacing of .120”.

8.6 G4PO Tolerance Analysis

Figure 28 shows a typical G4PO Board-to-Board tolerance analysis using a surface mount configuration. The BMI Length and associated Gap are dependent on the **Board-to-Board spacing, Shroud Reference Plane (R/P), and Solder Thickness.**

Determine the Shroud R/P to Shroud R/P spacing as follows:

.122 ± .0015	Board-to-Board
-.0235 ± .001	Shroud R/P
-.0235 ± .001	Shroud R/P
-.002 ± .001	Solder Thickness
-.002 ± .001	Solder Thickness
<hr/>	
.071 ± .0055	Shroud R/P to R/P

The **minimum Shroud R/P to R/P** spacing is therefore $.071 - .0055 = .0655$. This dimension is also the **maximum BMI Length**. This ensures that the BMI doesn't bottom out between the Shroud Reference Planes. The nominal BMI Length is the **minimum R/P to R/P** spacing minus the BMI Length tolerance (.0005). The **nominal BMI Length** is therefore $.0655 - .0005 = .065$.

Next, determine the Gap between the Smooth Bore Shroud R/P and the BMI as follows:

.071 ± .0055	Shroud R/P to Shroud R/P
-.065 ± .0005	BMI Length
<hr/>	
.006 ± .006	Gap

The tolerance analysis shows that the BMI can be flush (.006 - .006) to .012 (.006 + .006) away from the Smooth Bore Shroud R/P. The Gap tolerance should be minimized whenever possible to ensure optimal electrical performance.

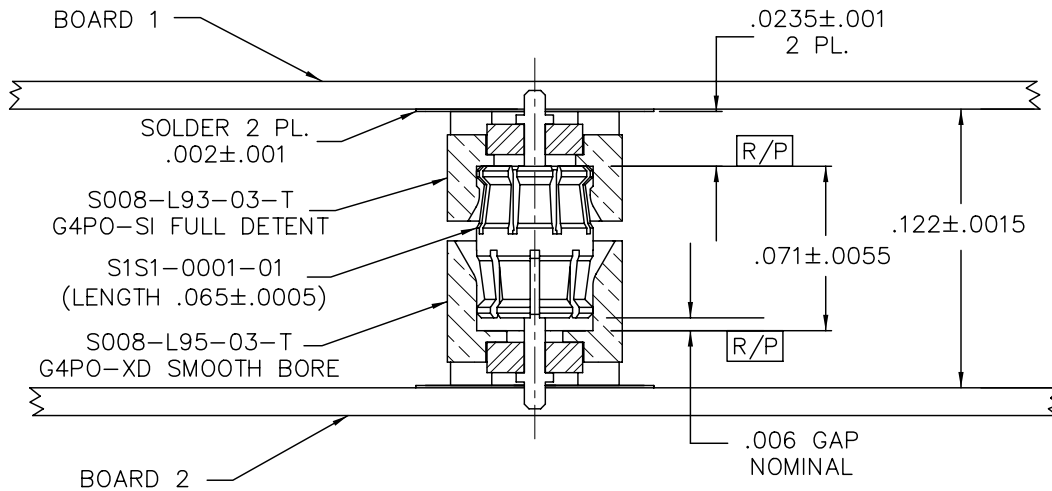

Figure 28 – G4PO Board-to-Board Tolerance Analysis

Please contact Applications Engineering to configure the G4PO minimum board-to-board spacing of .090”.

Index

JNQGX

Part Number	Description	Page	Part Number	Description	Page
00118-119-3-LD	GMS Adapters	128	0119-783-1	GPO Within Series Adapters	108
00119-011-3	GPO Between Series Adapters	117	0119-785-3	GPO Flange Mounts	21
00119-117-3	GPO Between Series Adapters	117	0119-843-3	GPO Within Series Adapters	108
00218-101-3	SGMS Adapters	131	0119-857-3	GPO Flange Mounts	21
00218-103-3	GMS Adapters	126	0119-881-1	GPO Cable Connectors	5
00218-201-3	SGMS Adapters	130	02018-315-3	GMS ESD Adapters	130
00218-301-3	GMS Adapters	126	02018-316-3	GMS ESD Adapters	129
00219-106-3	GPO Between Series Adapters	113	02018-317-3	GMS ESD Adapters	129
00219-125-3	GPO Between Series Adapters	111	02018-318-3	GMS ESD Adapters	129
00219-128-3	GPO Between Series Adapters	111	02018-320-4	GMS ESD Adapters	130
00219-142-3-V10	GPO Between Series Adapters	112	03501-210-1	GPO Between Series Adapters	116
00419-302-3	GPO Between Series Adapters	118	1619-001-1-FD	GPO PCB Mounts	17
00419-303-3	GPO Between Series Adapters	118	1619-001-1-LD	GPO PCB Mounts	17
0118-921-1	GPPO Blindmate Interconnects	37	1619-001-1-SB	GPO PCB Mounts	17
0118-927-1	GPPO Cable Connectors	40	1811-400-3	SGMS Flange Mounts	102
0118-928-4-CM	GPPO Cable Connectors	43	1811-401-3	SGMS Flange Mounts	102
0118-958-1	GPPO Cable Connectors	44	1881-001-1	SGMS Blindmate Interconnects	101
0118-958-4	GPPO Cable Connectors	44	1A1C2-0521-01	GPO Between Series Adapters	114
0118-959-1-FD-TAB	GPPO PCB Mounts	46	1A1D1-0501-01	GPO Between Series Adapters	115
0118-959-1-SB-TAB	GPPO PCB Mounts	46	1A1D2-0501-01	GPO Between Series Adapters	115
0118-960-1-FD-TAB	GPPO PCB Mounts	46	1A1F1-0503-01	GPO Between Series Adapters	113
0118-960-1-SB-TAB	GPPO PCB Mounts	46	1A1F2-0503-01	GPO Between Series Adapters	114
0118-961-4	GPPO Cable Connectors	42	1A3C1-0503-01	GPO Between Series Adapters	115
0119-228-1	GPO Thread-In Shrouds	26	1A3D1-0503-01	GPO Between Series Adapters	116
0119-248-1-CM	GPO Hermetic Shrouds	30	1A3D1-0513-01	GPO Between Series Adapters	116
0119-248-1-CM-T	GPO Hermetic Shrouds	30	1A3F1-0503-01	GPO Between Series Adapters	109
0119-248-1-FD	GPO Hermetic Shrouds	30	1A3F1-0513-02	GPO Between Series Adapters	112
0119-248-1-FD-T	GPO Hermetic Shrouds	30	1A3F1-0513-03	GPO Between Series Adapters	110
0119-248-1-LD	GPO Hermetic Shrouds	30	1A3F1-0513-04	GPO Between Series Adapters	113
0119-248-1-LD-T	GPO Hermetic Shrouds	30	1A3F1-0513-05	GPO Between Series Adapters	111
0119-248-1-SB	GPO Hermetic Shrouds	30	1A3F1-0523-01	GPO Between Series Adapters	109
0119-248-1-SB-T	GPO Hermetic Shrouds	30	1A3F1-0523-02	GPO Between Series Adapters	110
0119-258-3-FD	GPO Thread-In Shrouds	27	1A3F1-0523-05	GPO Between Series Adapters	110
0119-258-3-LD	GPO Thread-In Shrouds	27	1A3F2-0503-01	GPO Between Series Adapters	114
0119-258-3-SB	GPO Thread-In Shrouds	27	1A3G1-0533-01	GPO Between Series Adapters	117
0119-303-1	GPO Cable Connectors	11	1A3H1-0511-01	GMS Adapters	128
0119-392-3	GPO Cable Connectors	14	1A3H2-0533-01	GMS Adapters	128
0119-397-3-100	GPO Right Angle PCB Mounts	18	1A4D1-0503-01	GPO Between Series Adapters	116
0119-399-1	GPO Cable Connectors	7	1A4D1-0513-01	GPO Between Series Adapters	116
0119-424-3-1	GPO Thread-In Shrouds	27	1A4F1-0503-01	GPO Between Series Adapters	109
0119-424-3-2	GPO Thread-In Shrouds	27	1A4F1-0513-03	GPO Between Series Adapters	110
0119-424-3-3	GPO Thread-In Shrouds	27	1A4F1-0513-05	GPO Between Series Adapters	111
0119-424-3-4	GPO Thread-In Shrouds	27	1A4F1-0523-01	GPO Between Series Adapters	109
0119-441-3	GPO Flange Mounts	20	1A4F1-0523-02	GPO Between Series Adapters	110
0119-467-3	GPO Flange Mounts	20	1A4F2-0503-01	GPO Between Series Adapters	114
0119-502-3	GPO Within Series Adapters	109	1A5D1-0503-01	GPO Between Series Adapters	116
0119-546-3	GPO Cable Connectors	11	1A5D1-0513-01	GPO Between Series Adapters	116
0119-579-3	GPO Within Series Adapters	108	1A5F1-0503-01	GPO Between Series Adapters	109
0119-588-1	GPO Right Angle PCB Mounts	18	1A5F1-0513-02	GPO Between Series Adapters	112
0119-590-3	GPO Cable Connectors	15	1A5F1-0513-03	GPO Between Series Adapters	110
0119-632-3	GPO Within Series Adapters	107	1A5F1-0513-05	GPO Between Series Adapters	111
0119-711-1	GPO PCB Mounts	17	1A5F1-0523-01	GPO Between Series Adapters	109
0119-714-3	GPO Right Angle PCB Mounts	18	1A5F1-0523-05	GPO Between Series Adapters	110
0119-720-1	GPO Right Angle PCB Mounts	19	1A5F2-0503-01	GPO Between Series Adapters	114
0119-727-3-FD	GPO Cable Connectors	10	1A6F1-0513-02	GPO Between Series Adapters	112
0119-727-3-LD	GPO Cable Connectors	10	1B1A3-0541-01	GPPO Between Series Adapters	119
0119-727-3-SB	GPO Cable Connectors	10	1B1C1-0501-01	GPPO Between Series Adapters	121

Part Number	Description	Page	Part Number	Description	Page
1B1C2-0501-01	GPPO Between Series Adapters	121	A001-B85-02	GPO Cable Connectors	5
1B1F1-0503-01	GPPO Between Series Adapters	119	A001-D83-01	GPO Cable Connectors	6
1B1F2-0503-01	GPPO Between Series Adapters	120	A001-D83-02	GPO Cable Connectors	6
1B1M1-0509-01	GPPO Between Series Adapters	122	A001-D84-01	GPO Cable Connectors	6
1B1M2-0509-01	GPPO Between Series Adapters	122	A001-D84-02	GPO Cable Connectors	6
1B3C1-0503-01	GPPO Between Series Adapters	122	A001-D85-01	GPO Cable Connectors	6
1B3C2-0503-01	GPPO Between Series Adapters	121	A001-D85-02	GPO Cable Connectors	6
1B3F1-0503-01	GPPO Between Series Adapters	120	A001-N33-02	GPO Flange Mounts	19
1B3F2-0503-01	GPPO Between Series Adapters	120	A001-N33-05	GPO Flange Mounts	20
1B3M1-0509-01	GPPO Between Series Adapters	123	A001-N34-02	GPO Flange Mounts	19
1B3M2-0509-01	GPPO Between Series Adapters	123	A001-N34-05	GPO Flange Mounts	20
1B5C1-0503-01	GPPO Between Series Adapters	122	A001-N35-02	GPO Flange Mounts	19
1B5C2-0503-01	GPPO Between Series Adapters	121	A001-N35-05	GPO Flange Mounts	20
1B5F1-0503-01	GPPO Between Series Adapters	120	A003-A23-01	GPO Thread-In Shrouds	24
1B5F2-0503-01	GPPO Between Series Adapters	120	A003-A24-01	GPO Thread-In Shrouds	24
1B5M1-0509-01	GPPO Between Series Adapters	123	A003-A25-01	GPO Thread-In Shrouds	24
1B5M2-0509-01	GPPO Between Series Adapters	123	A003-A27-01	GPO Thread-In Shrouds	24
1F1H1-0501-01	GMS Adapters	127	A003-L11-01	GPO Thread-In Shrouds	25
1F1H2-0503-01	GMS Adapters	126	A003-L33-01	GPO Thread-In Shrouds	25
1F1P5-0503-01	SGMS Adapters	131	A003-L33-02	GPO Thread-In Shrouds	25
1F2H1-0501-01	GMS Adapters	127	A003-L34-01	GPO Thread-In Shrouds	25
1F2H2-0503-01	GMS Adapters	127	A003-L34-02	GPO Thread-In Shrouds	25
1R1M1-0509-01	G3PO Adapters	124	A003-L35-01	GPO Thread-In Shrouds	25
1R3D1-0503-01	G3PO Adapters	125	A003-L35-02	GPO Thread-In Shrouds	25
1R3F1-0509-01	G3PO Adapters	124	A003-N33-01	GPO Thread-In Shrouds	26
1R3M1-0509-01	G3PO Adapters	123	A003-N33-02	GPO Thread-In Shrouds	26
1R3M2-0503-01	G3PO Adapters	124	A003-N34-01	GPO Thread-In Shrouds	26
1R5D1-0503-01	G3PO Adapters	125	A003-N34-02	GPO Thread-In Shrouds	26
1R5F1-0509-01	G3PO Adapters	124	A003-N35-01	GPO Thread-In Shrouds	26
1R5M1-0509-01	G3PO Adapters	123	A003-N35-02	GPO Thread-In Shrouds	26
1R5M2-0503-01	G3PO Adapters	124	A005-A23-01	GPO Press-in Shrouds	27
1S3D2-0503-01	G4PO Adapters	125	A005-A23-02	GPO Press-in Shrouds	27
1S3M1-0503-01	G4PO Adapters	125	A005-A24-01	GPO Press-in Shrouds	27
1S5D2-0503-01	G4PO Adapters	125	A005-A24-02	GPO Press-in Shrouds	27
1S5M1-0503-01	G4PO Adapters	125	A005-A25-01	GPO Press-in Shrouds	27
2-S1A-S1A-16-L	G4PO Cable Assemblies	82	A005-A25-02	GPO Press-in Shrouds	27
2-S1C-S1C-16-L	G4PO Cable Assemblies	82	A005-L33-01	GPO Press-in Shrouds	28
6804-100-2	SGMS Thread-In Shrouds	103	A005-L34-01	GPO Press-in Shrouds	28
6804-100-3	SGMS Cable Connectors	101	A005-L35-01	GPO Press-in Shrouds	28
9001-820-4	GPO Tools	134	A007-L43-01-TAB-X	GPO Hermetic Shrouds	28
9001-823-0	GPPO Tools	145	A007-L43-02-TAB-X	GPO Hermetic Shrouds	28
9001-824-0	GPPO Tools	135, 145	A007-L43-03-TAB-X	GPO Hermetic Shrouds	29
A001-A23-03	GPO Flange Mounts	19	A007-L43-04-TAB-X	GPO Hermetic Shrouds	29
A001-A23-04	GPO Flange Mounts	19	A007-L43-14	GPO Hermetic Shrouds	29
A001-A23-07	GPO Flange Mounts	19	A007-L44-01-TAB-X	GPO Hermetic Shrouds	28
A001-A24-03	GPO Flange Mounts	19	A007-L44-02-TAB-X	GPO Hermetic Shrouds	28
A001-A24-04	GPO Flange Mounts	19	A007-L44-03-TAB-X	GPO Hermetic Shrouds	29
A001-A24-07	GPO Flange Mounts	19	A007-L44-04-TAB-X	GPO Hermetic Shrouds	29
A001-A25-03	GPO Flange Mounts	19	A007-L45-01-TAB-X	GPO Hermetic Shrouds	28
A001-A25-04	GPO Flange Mounts	19	A007-L45-02-TAB-X	GPO Hermetic Shrouds	28
A001-A25-07	GPO Flange Mounts	19	A007-L45-03-TAB-X	GPO Hermetic Shrouds	29
A001-B83-01	GPO Cable Connectors	5	A007-L45-04-TAB-X	GPO Hermetic Shrouds	29
A001-B83-02	GPO Cable Connectors	5	A008-L13-03	GPO PCB Mounts	15
A001-B84-01	GPO Cable Connectors	5	A008-L14-03	GPO PCB Mounts	15
A001-B84-02	GPO Cable Connectors	5	A008-L15-03	GPO PCB Mounts	15
A001-B85-01	GPO Cable Connectors	5	A008-L33-01	GPO PCB Mounts	15

Part Number	Description	Page	Part Number	Description	Page
A008-L33-02	GPO PCB Mounts	15	A016-B84-01	GPO Cable Connectors	11
A008-L33-05	GPO PCB Mounts	16	A016-B86-01	GPO Cable Connectors	11
A008-L33-06	GPO PCB Mounts	16	A016-D53-01	GPO Cable Connectors	12
A008-L34-01	GPO PCB Mounts	15	A016-D54-01	GPO Cable Connectors	12
A008-L34-02	GPO PCB Mounts	15	A016-D55-01	GPO Cable Connectors	12
A008-L34-05	GPO PCB Mounts	16	A016-D73-03	GPO Cable Connectors	12
A008-L35-01	GPO PCB Mounts	15	A016-D74-03	GPO Cable Connectors	12
A008-L35-02	GPO PCB Mounts	15	A016-D76-03	GPO Cable Connectors	12
A008-L35-05	GPO PCB Mounts	16	A016-D83-01	GPO Cable Connectors	12
A008-P33-01	GPO PCB Mounts	16	A016-D84-01	GPO Cable Connectors	12
A008-P34-01	GPO PCB Mounts	16	A016-D86-01	GPO Cable Connectors	12
A008-P35-01	GPO PCB Mounts	16	A016-D87-01	GPO Cable Connectors	13
A009-P33-01	GPO Right Angle PCB Mounts	17	A016-G86-01	GPO Cable Connectors	13
A009-P33-03	GPO Right Angle PCB Mounts	17	A016-H83-01	GPO Cable Connectors	13
A009-P34-01	GPO Right Angle PCB Mounts	17	A016-H84-01	GPO Cable Connectors	13
A009-P34-03	GPO Right Angle PCB Mounts	17	A016-H85-01	GPO Cable Connectors	13
A009-P35-01	GPO Right Angle PCB Mounts	17	A018-B71-01	GPO Cable Connectors	14
A009-P35-03	GPO Right Angle PCB Mounts	17	A018-B71-02	GPO Cable Connectors	14
A010-L13-02	GPO Edge Mounts	21	A018-F71-01	GPO Cable Connectors	14
A010-L14-02	GPO Edge Mounts	21	A033-B93-02-4	GPO Multiposition Blocks	33
A010-L15-02	GPO Edge Mounts	21	A033-D53-01	GPO Multiposition Blocks	34
A010-L33-01	GPO Edge Mounts	22	A036-P95-01-4	GPO Multiposition Blocks	33
A010-L33-02	GPO Edge Mounts	22	A055-A11-01	GPO Loads	30
A010-L33-03	GPO Edge Mounts	22	A055-A11-02	GPO Loads	30
A010-L33-04	GPO Edge Mounts	22	A055-A14-01	GPO Loads	31
A010-L34-01	GPO Edge Mounts	22	A055-A14-02	GPO Loads	31
A010-L34-02	GPO Edge Mounts	22	A055-A15-01	GPO Loads	31
A010-L34-03	GPO Edge Mounts	22	A055-A15-02	GPO Loads	31
A010-L34-04	GPO Edge Mounts	22	A090-A99-01	GPO Tools	136
A010-L35-01	GPO Edge Mounts	22	A090-A99-03	GPO Tools	136
A010-L35-02	GPO Edge Mounts	22	A090-A99-07	GPO Tools	136
A010-L35-03	GPO Edge Mounts	22	A090-A99-09	GPO Tools	136
A010-L35-04	GPO Edge Mounts	22	A090-A99-10	GPO Tools	137
A012-A93-01	GPO Surface Mounts	23	A090-A99-11	GPO Tools	137
A012-A94-01	GPO Surface Mounts	23	A093-A99-01	GPO Tools	140
A012-A95-01	GPO Surface Mounts	23	A095-A99-01	GPO Tools	134, 139
A012-L96-01	GPO Surface Mounts	23	A095-A99-03	GPO Tools	134, 139
A012-P93-01	GPO Surface Mounts	23	A096-A99-01	GPO Tools	137
A012-P93-04	GPO Surface Mounts	24	A096-A99-02	GPO Tools	137
A012-P94-01	GPO Surface Mounts	23	A096-A99-04	GPO Tools	138
A012-P94-04	GPO Surface Mounts	24	A096-A99-06	GPO Tools	138
A012-P95-01	GPO Surface Mounts	23	A096-A99-07	GPO Tools	138
A012-P95-04	GPO Surface Mounts	24	A096-A99-08	GPO Tools	138
A014-B11-01	GPO Cable Connectors	5	A096-A99-09	GPO Tools; GMS Tools	139, 147
A014-D11-01	GPO Cable Connectors	6	A097-A99-01	GPO Tools	134
A014-D11-02	GPO Cable Connectors	6	A097-A99-02	GPO Tools	134
A014-F71-01	GPO Cable Connectors	7	A097-A99-03	GPO Tools	134
A014-H71-01	GPO Cable Connectors	7	A098-A98-08	GPO Tools	134
A015-B11-01	GPO Cable Connectors	8	A098-A99-01	GPO Tools	140
A015-B11-02	GPO Cable Connectors	8	A098-A99-02	GPO Tools	134, 140
A015-B71-01	GPO Cable Connectors	8	A098-A99-03	GPO Tools	141
A015-B71-03	GPO Cable Connectors	9	A098-A99-04	GPO Tools	139
A015-D11-01	GPO Cable Connectors	9	A098-A99-05	GPO Tools	134, 141
A015-D11-03	GPO Cable Connectors	9	A098-A99-08	GPO Tools	140
A015-F71-01	GPO Cable Connectors	10	A098-A99-10	GPO Tools	134, 141
A015-H71-01	GPO Cable Connectors	10	A1A1-0001-01	GPO Blindmate Interconnect	3
A016-B83-01	GPO Cable Connectors	11	A1A1-0001-02	GPO Blindmate Interconnect	3

Part Number	Description	Page	Part Number	Description	Page
A1A1-0001-03	GPO Blindmate Interconnect	3	B010-A95-13	GPPO Multiposition Blocks	61
A1A1-0001-07	GPO Blindmate Interconnect	3	B010-L13-01	GPPO Flange Mounts	48
A1A1-0001-08	GPO Blindmate Interconnect	3	B010-L15-01	GPPO Flange Mounts	48
A1A1-0001-09	GPO Blindmate Interconnect	3	B010-L33-03	GPPO Edge Mounts	49
A1A1-0001-11	GPO Blindmate Interconnect	3	B010-L33-04	GPPO Edge Mounts	49
A1A1-0001-12	GPO Blindmate Interconnect	3	B010-L35-03	GPPO Edge Mounts	49
A1A1-0001-21	GPO Blindmate Interconnect	3	B010-L35-04	GPPO Edge Mounts	49
A1A1-0001-24	GPO Blindmate Interconnect	4	B010-L73-01-T	GPPO Edge Mounts	48
A1A1-0001-25	GPO Blindmate Interconnect	3	B010-L83-01	GPPO Edge Mounts	49
A1A1-0001-29	GPO Blindmate Interconnect	3	B010-L83-02	GPPO Edge Mounts	50
A1A1-0001-34	GPO Blindmate Interconnect	4	B010-L85-01	GPPO Edge Mounts	49
A1A1-0547-01	GPO Blindmate Interconnect	4	B010-L85-02	GPPO Edge Mounts	50
A1A3-0503-01	GPO Within Series Adapters	107	B011-A93-01	GPPO Multiposition Blocks	61
A1A4-0503-01	GPO Within Series Adapters	107	B012-L13-01	GPPO Surface Mounts	50
A1A5-0503-01	GPO Within Series Adapters	107	B012-L13-02	GPPO Surface Mounts	50
A3A3-0539-01	GPO Within Series Adapters	107	B012-L13-03	GPPO Surface Mounts	50
A3A6-0539-01	GPO Within Series Adapters	107	B012-L13-04	GPPO Surface Mounts	50
B001-A23-01	GPPO Flange Mounts	47	B012-L15-01	GPPO Surface Mounts	50
B001-A23-02	GPPO Flange Mounts	47	B012-L15-02	GPPO Surface Mounts	50
B001-A25-01	GPPO Flange Mounts	47	B012-L15-03	GPPO Surface Mounts	50
B001-A25-02	GPPO Flange Mounts	47	B012-L15-04	GPPO Surface Mounts	50
B001-D33-01	GPPO Cable Connectors	45	B012-P93-01	GPPO Surface Mounts	50
B001-D35-01	GPPO Cable Connectors	45	B012-P93-02	GPPO Surface Mounts	51
B001-K33-01	GPPO Cable Connectors	45	B012-P95-01	GPPO Surface Mounts	50
B001-K35-01	GPPO Cable Connectors	45	B012-P95-02	GPPO Surface Mounts	51
B001-N33-01	GPPO Flange Mounts	48	B013-L93-01	GPPO Surface Mounts	51
B001-N35-01	GPPO Flange Mounts	48	B013-L95-01	GPPO Surface Mounts	51
B003-A23-01	GPPO Thread-in Shrouds	51	B014-B11-01	GPPO Cable Connectors	38
B003-A25-01	GPPO Thread-in Shrouds	51	B014-D11-01	GPPO Cable Connectors	39
B003-L33-01	GPPO Thread-in Shrouds	52	B014-K11-01	GPPO Cable Connectors	39
B003-L33-02	GPPO Thread-in Shrouds	52	B015-B11-01	GPPO Cable Connectors	39
B003-L33-03	GPPO Thread-in Shrouds	52	B015-B11-02	GPPO Cable Connectors	40
B003-L33-05	GPPO Thread-in Shrouds	52	B015-B11-04	GPPO Cable Connectors	40
B003-L35-01	GPPO Thread-in Shrouds	52	B015-D11-01	GPPO Cable Connectors	41
B003-L35-02	GPPO Thread-in Shrouds	52	B015-D11-02	GPPO Cable Connectors	41
B003-L35-03	GPPO Thread-in Shrouds	52	B016-B11-01	GPPO Cable Connectors	44
B003-L35-05	GPPO Thread-in Shrouds	52	B016-B33-01	GPPO Cable Connectors	41
B003-N33-01	GPPO Thread-in Shrouds	53	B016-B33-02	GPPO Cable Connectors	42
B003-N33-02	GPPO Thread-in Shrouds	53	B016-B35-01	GPPO Cable Connectors	41
B003-N35-01	GPPO Thread-in Shrouds	53	B016-B35-02	GPPO Cable Connectors	42
B003-N35-02	GPPO Thread-in Shrouds	53	B016-D33-01	GPPO Cable Connectors	42
B007-L45-04-TAB	GPPO Multiposition Blocks	58	B016-D33-02	GPPO Cable Connectors	43
B007-L45-15	GPPO Multiposition Blocks	57	B016-D35-01	GPPO Cable Connectors	42
B007-L45-15-T	GPPO Multiposition Blocks	58	B016-D35-02	GPPO Cable Connectors	43
B007-M43-01-TAB-X	GPPO Hermetic Shrouds	54	B019-K36-01	GPPO Cable Connectors	43
B007-M45-01-TAB-X	GPPO Hermetic Shrouds	54	B019-K36-02	GPPO Cable Connectors	43
B007-M46-01-TAB-X	GPPO Hermetic Shrouds	54	B019-K36-03	GPPO Cable Connectors	43
B008-L13-01	GPPO PCB Mounts	45	B024-L33-01	GPPO Thread-in Shrouds	53
B008-L13-05	GPPO Multiposition Blocks	62	B024-L33-02	GPPO Thread-in Shrouds	54
B008-L15-01	GPPO PCB Mounts	45	B024-L35-01	GPPO Thread-in Shrouds	53
B008-P33-01	GPPO PCB Mounts	46	B024-L35-02	GPPO Thread-in Shrouds	54
B008-P35-01	GPPO PCB Mounts	46	B030-L93-02-7	GPPO Multiposition Blocks	62
B009-P33-01	GPPO PCB Mounts	47	B030-L95-02-7	GPPO Multiposition Blocks	62
B009-P33-02	GPPO PCB Mounts	47	B031-B93-01-4	GPPO Multiposition Blocks	59
B009-P35-01	GPPO PCB Mounts	47	B031-B93-01-6	GPPO Multiposition Blocks	59
B009-P35-02	GPPO PCB Mounts	47	B031-B93-02-4	GPPO Multiposition Blocks	60
B010-A95-07	GPPO Multiposition Blocks	63	B031-B93-03-4	GPPO Multiposition Blocks	60

Part Number	Description	Page	Part Number	Description	Page
B055-A11-01	GPPO Loads.....	55	H019-R32-01	GMS Cable Connectors.....	92
B055-A11-02	GPPO Loads.....	55	H025-D11-01	GMS Cable Connectors.....	92
B055-A11-05	GPPO Loads.....	55	H025-D32-01	GMS Cable Connectors.....	91
B055-A11-06	GPPO Loads.....	56	H055-A11-01	GMS Loads.....	95
B055-A13-01	GPPO Loads.....	55	H055-A12-01	GMS Loads.....	95
B055-A13-02	GPPO Loads.....	55	H055-A32-02	GMS ESD Load.....	97
B055-A15-01	GPPO Loads.....	55	H096-A99-01	GMS Tools.....	147
B055-A15-02	GPPO Loads.....	55	H098-A99-01	GMS Tools.....	147
B090-A99-05	GPPO Tools.....	142	L096-A99-01	Miscellaneous Tools.....	148
B090-A99-06	GPPO Tools.....	143	L096-A99-02	Miscellaneous Tools.....	148
B090-A99-07	GPPO Tools.....	143	L096-A99-03	Miscellaneous Tools.....	148
B095-A99-01	GPPO Tools.....	135, 144	P001-K94-01	SGMS Cable Connectors.....	101
B095-A99-05	GPPO Tools.....	135, 144	P001-K95-01	SGMS Cable Connectors.....	101
B096-A93-01	GPPO Tools.....	142	P001-M35-01	SGMS Flange Mounts.....	102
B096-A99-01	GPPO Tools.....	142	P003-L35-01	SGMS Thread-In Shrouds.....	103
B096-A99-02	GPPO Tools.....	142	P016-K94-01	SGMS Cable Connectors.....	102
B097-A99-01	GPPO Tools.....	135	P016-K95-01	SGMS Cable Connectors.....	102
B097-A99-02	GPPO Tools.....	135	P032-L16-01	SGMS Multiposition Blocks.....	104
B098-A99-01	GPPO Tools.....	142	P033-D14-01	SGMS Multiposition Blocks.....	104
B098-A99-02	GPPO Tools.....	135, 143	R007-L43-05-TAB-R...	G3PO Hermetic Shrouds.....	70
B098-A99-03	GPPO Tools.....	135, 143	R007-L45-05-TAB-R...	G3PO Hermetic Shrouds.....	70
B098-A99-05	GPPO Tools.....	135	R007-T43-01	G3PO Multiposition Blocks.....	73
B098-A99-07	GPPO Tools.....	135, 144	R007-T45-01	G3PO Multiposition Blocks.....	73
B098-A99-08	GPPO Tools.....	135, 144	R008-L13-02	G3PO PCB Mounts.....	69
B1B1-0001-01	GPPO Blindmate Interconnects.....	37	R008-L16-01	G3PO PCB Mounts.....	69
B1B1-0001-02	GPPO Blindmate Interconnects.....	37	R010-L13-03	G3PO Edge Mounts.....	69
B1B1-0001-03	GPPO Blindmate Interconnects.....	37	R010-L15-03	G3PO Edge Mounts.....	69
B1B1-0001-05	GPPO Blindmate Interconnects.....	37	R012-T95-01	G3PO Surface Mounts.....	70
B1B1-0001-07	GPPO Blindmate Interconnects.....	37	R014-B11-01	G3PO Cable Connectors.....	68
B1B1-0001-08	GPPO Blindmate Interconnects.....	37	R014-B13-01	G3PO Cable Connectors.....	68
B1B1-0001-09	GPPO Blindmate Interconnects.....	37	R014-B15-01	G3PO Cable Connectors.....	68
B1B1-0001-10	GPPO Blindmate Interconnects.....	38	R015-B11-02	G3PO Cable Connectors.....	68
B1B1-0001-11	GPPO Blindmate Interconnects.....	38	R032-L95-01	G3PO Multiposition Blocks.....	75
B3B3-0523-01	GPPO Within Series Adapters.....	118	R033-B53-01	G3PO Multiposition Blocks.....	75
B3B3-0523-02	GPPO Within Series Adapters.....	119	R036-P93-01	G3PO Multiposition Blocks.....	74
B3B5-0523-02	GPPO Within Series Adapters.....	119	R036-T45-01	G3PO Multiposition Blocks.....	72
B5B3-0523-01	GPPO Within Series Adapters.....	118	R036-T45-02	G3PO Multiposition Blocks.....	72
B5B3-0523-02	GPPO Within Series Adapters.....	119	R036-T93-01	G3PO Multiposition Blocks.....	73
B5B5-0523-02	GPPO Within Series Adapters.....	119	R036-T93-05	G3PO Multiposition Blocks.....	76
H001-D32-01	GMS Cable Connectors.....	91	R036-T93-06	G3PO Multiposition Blocks.....	76
H001-L11-01	GMS Flange Mounts.....	95	R036-T93-07	G3PO Multiposition Blocks.....	77
H001-M11-02	GMS ESD Flange Mounts.....	96	R036-T95-02	G3PO Multiposition Blocks.....	74
H001-M11-03	GMS ESD Flange Mounts.....	96	R036-T95-05	G3PO Multiposition Blocks.....	76
H001-N11-01	GMS Flange Mounts.....	94	R036-T95-06	G3PO Multiposition Blocks.....	76
H001-N11-04	GMS ESD Flange Mounts.....	96	R036-T95-07	G3PO Multiposition Blocks.....	77
H001-N11-05	GMS ESD Flange Mounts.....	96	R055-A11-01	G3PO Loads.....	70
H001-R32-01	GMS Cable Connectors.....	93	R055-A11-02	G3PO Loads.....	71
H014-B31-01	GMS ESD Cable Connectors.....	96	R055-A13-01	G3PO Loads.....	71
H014-K11-01	GMS Cable Connectors.....	94	R055-A15-01	G3PO Loads.....	71
H016-D11-01	GMS Cable Connectors.....	91	R095-A99-01	G3PO Tools.....	135, 145
H016-R11-01	GMS Cable Connectors.....	93	R098-A99-01	G3PO Tools.....	135, 145
H018-D32-06	GMS ESD Cable Connectors.....	97	R1R1-0001-01	G3PO Blindmate Interconnects.....	67
H018-D32-07	GMS ESD Cable Connectors.....	97	R1R1-0001-03-118....	G3PO Blindmate Interconnects.....	67
H018-K12-01	GMS Cable Connectors.....	94	R1R1-0001-03-134....	G3PO Blindmate Interconnects.....	67
H018-K32-01	GMS Cable Connectors.....	93	R1R1-0001-03-188....	G3PO Blindmate Interconnects.....	67
H018-R32-02	GMS ESD Cable Connectors.....	97	R1R1-0001-04	G3PO Blindmate Interconnects.....	67
H018-S32-01	GMS Cable Connectors.....	92	S007-L43-02-TAB-R....	G4PO Hermetic Shrouds.....	85

Part Number	Description	Page	Part Number	Description	Page
S007-L43-03-T	G4PO PCB Mounts	83	S036-T43-10	G4PO Multiposition Blocks	87
S007-L43-04-T	G4PO PCB Mounts	83	S036-T43-11	G4PO Multiposition Blocks	88
S007-L45-02-TAB-R	G4PO Hermetic Shrouds	85	S036-T45-03	G4PO Multiposition Blocks	86
S007-L45-03-T	G4PO PCB Mounts	83	S036-T45-04	G4PO Multiposition Blocks	87
S007-L45-04-T	G4PO PCB Mounts	83	S036-T45-05	G4PO Multiposition Blocks	88
S008-L93-03-T	G4PO PCB Mounts	83	S036-T45-06	G4PO Multiposition Blocks	86
S008-L93-03-T	G4PO PCB Mounts	83	S036-T45-07	G4PO Multiposition Blocks	87
S008-L95-03-T	G4PO PCB Mounts	83	S036-T45-08	G4PO Multiposition Blocks	88
S008-L95-04-T	G4PO PCB Mounts	82	S036-T45-09	G4PO Multiposition Blocks	86
S008-L93-04-T	G4PO PCB Mounts	82	S036-T45-10	G4PO Multiposition Blocks	87
S010-L13-01	G4PO Edge Mounts	84	S036-T45-11	G4PO Multiposition Blocks	88
S010-L15-01	G4PO Edge Mounts	84	S094-A91-01	G4PO Tools	135, 146
S012-T43-01	G4PO Surface Mounts	84	S095-A99-01	G4PO Tools	135, 146
S012-T43-02	G4PO Surface Mounts	84	S151-0001-01-TAB	G4PO Blindmate Interconnects	81
S012-T45-01	G4PO Surface Mounts	84	S151-0001-03-TAB	G4PO Blindmate Interconnects	81
S012-T45-02	G4PO Surface Mounts	84	Y007-L42-01	GPPO Hermetic Seals	56
S032-L93-01-T	G4PO Multiposition Blocks	85	Y007-L42-02	GPO Hermetic Seals	31
S032-L93-02-T	G4PO Multiposition Blocks	85	Y007-L42-03	GPO Hermetic Seals	31
S032-L95-01-T	G4PO Multiposition Blocks	85	Y007-L42-04	GPO Hermetic Seals	31
S032-L95-02-T	G4PO Multiposition Blocks	85	Y007-L42-05	GPPO Hermetic Seals	56
S036-T43-03	G4PO Multiposition Blocks	86	Y071-L02-01	GPPO Pins	56
S036-T43-04	G4PO Multiposition Blocks	87	Y071-L02-02	G3PO Pin	71
S036-T43-05	G4PO Multiposition Blocks	88	Y071-L92-01	GPPO Pins	57
S036-T43-06	G4PO Multiposition Blocks	86	Y071-L92-02	GPO Pins	31
S036-T43-07	G4PO Multiposition Blocks	87	Y071-L92-03	GPO Pins	32
S036-T43-08	G4PO Multiposition Blocks	88	Y071-L92-04	GPO Pins	32
S036-T43-09	G4PO Multiposition Blocks	86			

Corning Gilbert Inc.
Microwave Products

5310 West Camelback Road
Glendale, Arizona 85301 USA

phone: 800 651 8869 (US and Canada)
(01) 623 845 5613 (International)
fax: (01) 623 934 5160

website: www.corning.com/gilbert
e-mail: pushon-info@corning.com

© Corning Gilbert Inc. G-1500-102 05/11