

# Corrugated Polycarbonate Installation Instructions

Corrugated polycarbonate sheet can be used on both gable and arched style greenhouses. These easy to install panels can be attached directly to the greenhouse frame using one of several suggested fastener methods.

Corrugated polycarbonate sheets can replace existing greenhouse coverings including double polyethylene, fiberglass or glass. The following information provides an overview of the proper installation procedure.

## Bending/Burying

Corrugated Polycarbonate is sufficiently flexible to allow curves with a minimum radius of 158". Flexing or installing a sheet to the point of buckling can cause rapid deterioration in highly stressed areas.

For added strength and rodent control, sheets at ground level may be buried 4" to 6".

## Overlaps

On horizontal overlaps, the upper sheet should overlap the lower sheet by 3" to 4". Vertical overlap should be a single corrugation and should be overlapped in the direction of the prevailing wind. Since the finished width of the corrugated polycarbonate sheet is 51", the yield from a sheet is 48".

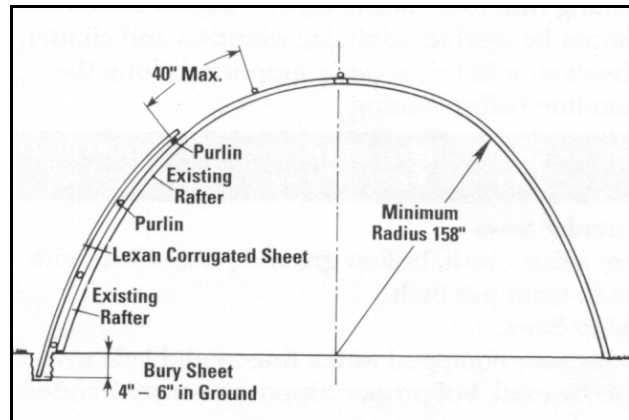

Bending/Burying

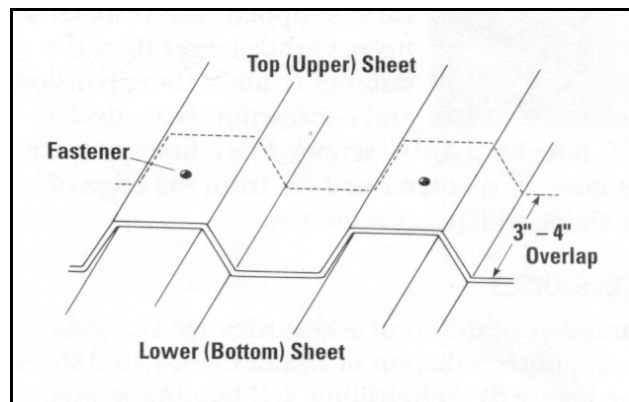

Horizontal Overlap

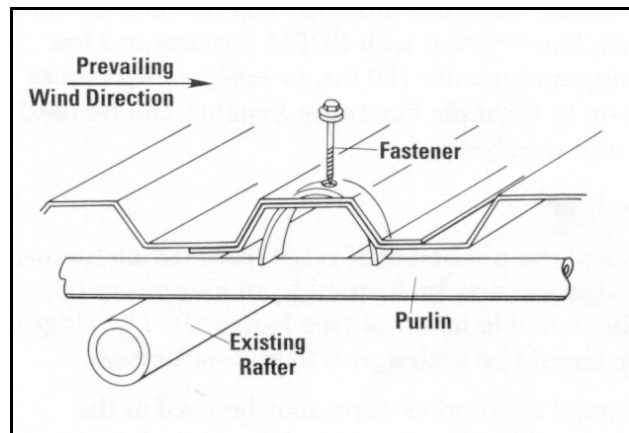

Vertical Overlap

## Cutting

Corrugated polycarbonate sheet can be cut with a variety of common hand-held and table-mounted equipment. In general, sharp tooling with fine cutting teeth should be used to minimize vibration and chatter. Sheets should be properly supported along the trim line before cutting.

## Circular Saws

Use a fine-tooth, hollow ground panel blade with 10-12 teeth per inch.

## Saber Saws

Saber saws equipped with a fine-tooth blade can also be used, but proper support is recommended.

## Drilling

Drill with a high-speed steel or carbide tipped twist drill. Drill holes slightly larger than the fastener to allow for expansion and contraction. (e.g., drill a 1/4" hole for a 3/16" screw). Place holes at twice the fastener diameter or 1/2" from the edge of the sheet, whichever is greater.

## Accessories

A number of different accessories are available to simplify the installation of corrugated polycarbonate sheeting. Self-drilling, self-tapping screws with neoprene washers are for aluminum or steel substructures; woodgrip screws are for wood substructures. Self-tapping screws with sharp points should be used with "no-drip" spacers.

## Sealing

To seal the pitched roof ridge from the elements, a ridge cap may be formed from aluminum or other suitable material. The ridge cap should be sealed with foam weatherseal.

Foamed or wood closures may be used at the ridge peak and gutter to seal the greenhouse. Closures should have a profile and be made of materials compatible with Corrugated Polycarbonate Sheet. Use a high quality, compatible sealant such as silicone rubber to seal holes or overlaps.

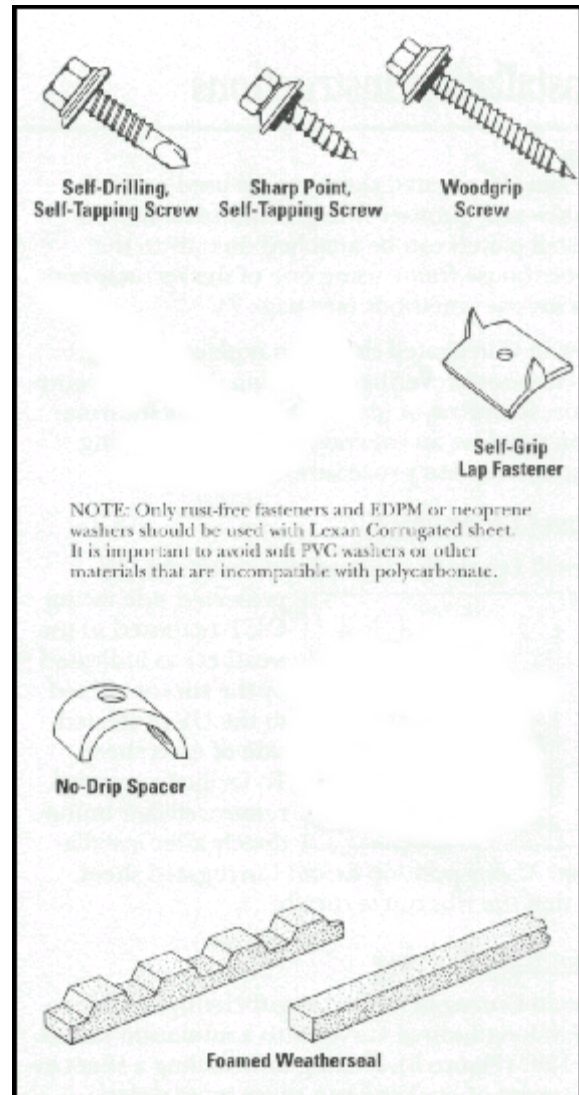

Available Accessories

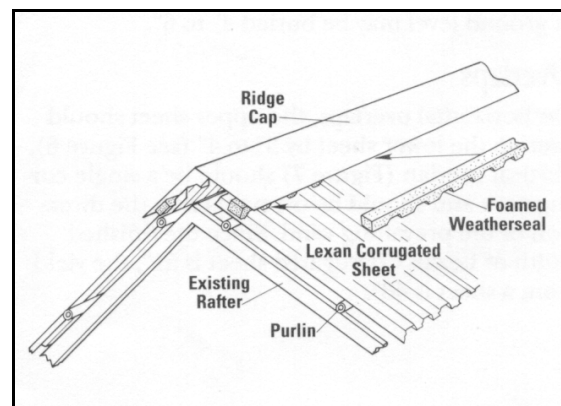

Ridge Sealing

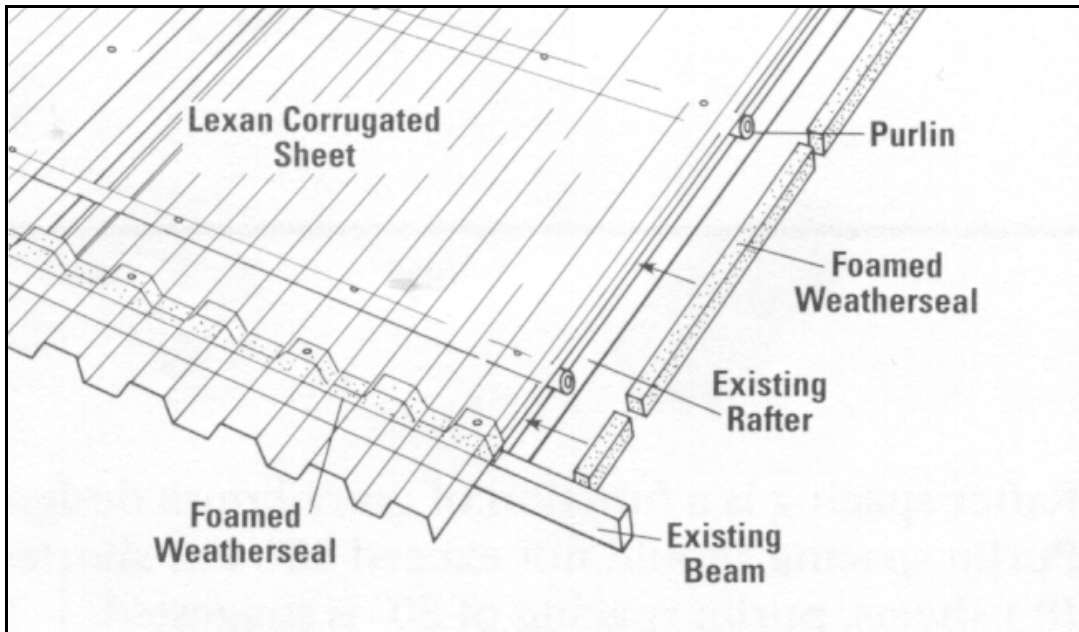

**Peak and Gutter Sealing**

### Fastening

Depending on wind exposure, Corrugated polycarbonate should be fastened to the greenhouse substructure at the bottom or top of every other corrugation. At the ridge and gutter, the edges of the sheet should be fastened at the bottom or top of every corrugation.

Corrugated Polycarbonate can be fastened directly to a wooden or metal greenhouse substructure.

The screws used to fasten Corrugated Polycarbonate should have neoprene or EPDM washers. If the attachment point is in the valley, another washer should be placed against the inside surface to separate the sheet from the wood or metal and prevent moisture/condensate droplets from developing. However, if the sheet is fastened through the top of the of a ridge corrugation, a “no-drip” spacer should be used.

Fastening vertical overlapping sheets together between the purlins can be accomplished with the use of “lap fasteners”.

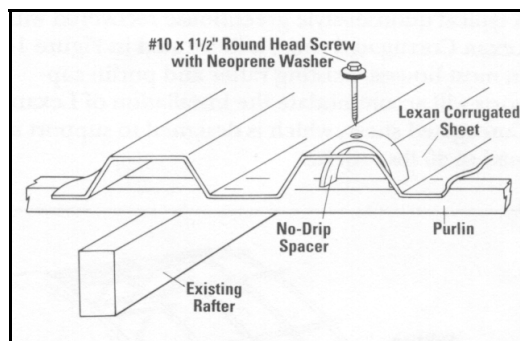

**Fastening at top with “No-Drip” Spacer**

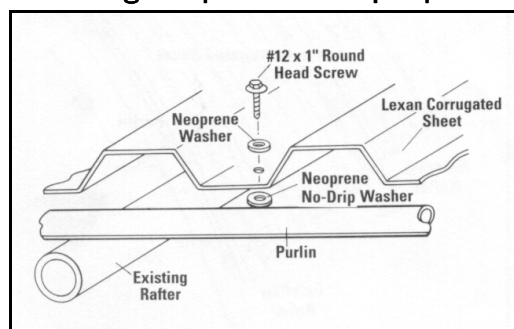

**Fastening at valley w/ “No-Drip” Spacer**

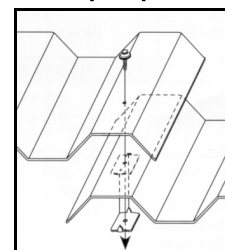

**Lap Fastener**

# Quonset-Style Greenhouses

## Fastening

A typical quonset style greenhouse covered with Corrugated Polycarbonate Sheet is shown below. In most houses, existing rafter and purlin supports will accommodate the installation of Corrugated Polycarbonate, which is designed to support a load of 40 lbs./sq. ft.

Rafter spacing is a function of greenhouse design. Purlin spacing should not exceed 40". For shorter (8') sheets, purlin spacing of 30" is suggested. Typical rafter and purlin support construction and details are illustrated below. In designs with lower load requirements, increased spacing can be used.

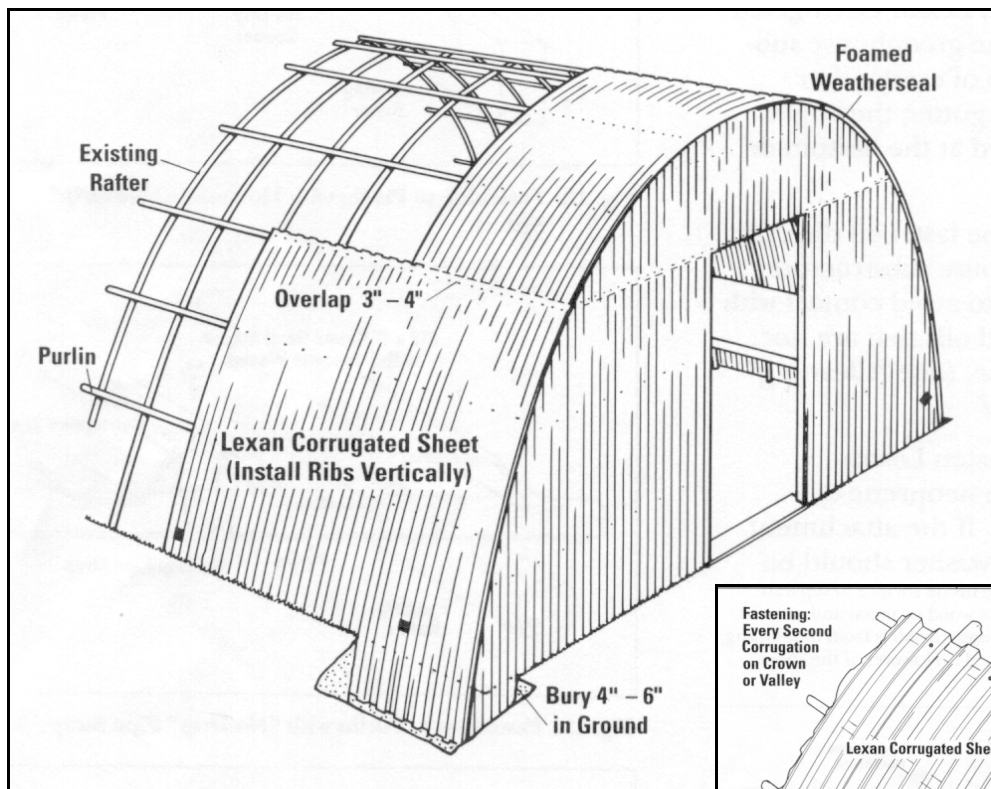

Quonset Style Greenhouse Installation

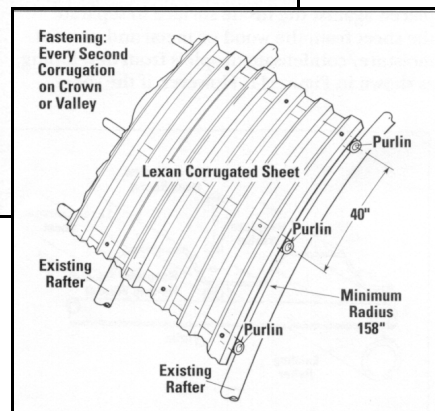

Quonset Details

# Gable Style Greenhouses

## Rafter and Purlin Supports

A typical gable style greenhouse recovered with Corrugated Polycarbonate Sheet is shown below. In most pitched roof greenhouses, existing rafter and purlin supports will accommodate installation of Corrugated Polycarbonate sheets.

Spacing of existing rafters is a function of greenhouse design. To obtain a 40 lb./sq. ft. loading purlin spacing should not exceed 24". It is recommended that a minimum roof pitch of 3:12 be maintained

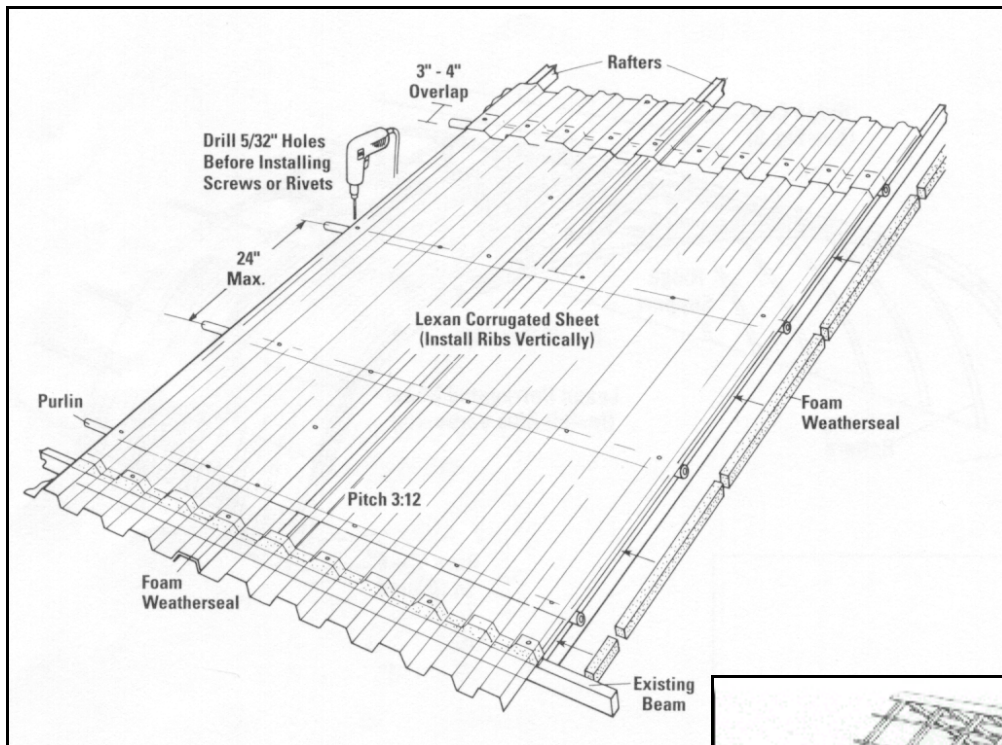

Gable Roof Greenhouse Rafter and Purlin Supports

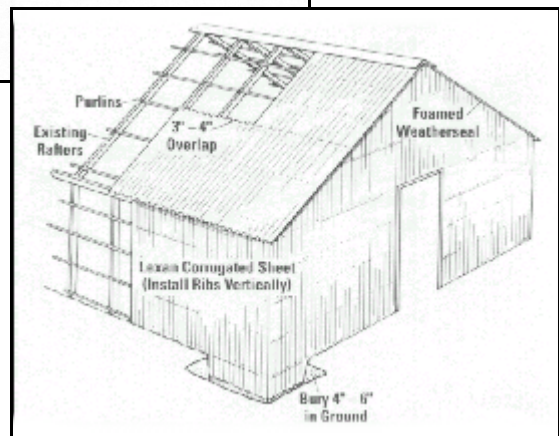

Gable Roof Greenhouse Installation

**IGC International Greenhouse Company**  
*The people who know greenhouses*  
Call Toll Free - 1-888-281-9337  
<http://www.igcusa.com>