

Fisher™ HP and HPA Control Valves

Contents

Introduction	1
Scope of Manual	1
Description	2
Specifications	3
Educational Services	3
Installation	3
Maintenance	6
Packing Lubrication	8
Packing Maintenance	8
Adding Packing Rings	8
Replacing Packing	9
Trim Removal	14
Valve Plug Maintenance	15
Lapping Seats	17
Trim Replacement	20
Retrofit: Installing C-seal Trim	24
Replacement of Installed C-seal Trim	26
Trim Removal (C-seal Constructions)	26
Lapping Metal Seats (C-seal Constructions) ..	27
Remachining Metal Seats (C-seal Constructions)	27
Trim Replacement (C-seal Constructions) ...	28
Parts Ordering	30
Parts Kits	30
Parts List	36

Figure 1. HP Valve with 667 Actuator and FIELDVUE™ DVC6200 Digital Valve Controller



X0183-1

Introduction

Scope of Manual

This instruction manual includes installation, maintenance, and parts information for NPS 1 through 6 HP valves with CL900 and CL1500 ratings; NPS 1 through 2 HP with CL2500 ratings; NPS 1 through 8 HPA valves with CL900 and CL1500 ratings; and NPS 1 through 2 HPA valves with CL2500 ratings. Refer to separate manuals for instructions covering the actuator, positioner, and accessories.

Do not install, operate, or maintain HP series valves without being fully trained and qualified in valve, actuator, and accessory installation, operation, and maintenance. To avoid personal injury or property damage, it is important to carefully read, understand, and follow all the contents of this manual, including all safety cautions and warnings. If you have any questions about these instructions, contact your [Emerson sales office](#) or Local Business Partner before proceeding.

Unless otherwise noted, all NACE references are to NACE MR0175-2002 and MR0103.

Table 1. Specifications

<p>End Connection Styles and Ratings^(1,2,3,4)</p> <p>Flanged: Consistent with CL900, CL1500, and CL2500 per ASME B16.34</p> <p>Socket Welding: Consistent with CL900, CL1500, and CL2500 per ASME B16.34</p> <p>Buttwelding: Consistent with CL900, CL1500, and CL2500 per ASME B16.34</p> <p>Also see table 2</p> <p>Shutoff Classifications</p> <p>See table 3</p> <p>C-seal trim: High-temperature, Class V. See table 4</p> <p>TSO (Tight Shutoff) trim: See tables 5 and 6</p> <p>Flow Characteristic</p> <p>Standard Cage: ■ Equal percentage, ■ Modified equal percentage, or ■ Linear</p> <p>Standard Cage with Micro-Form Valve Plug: (HPS and HPAS only): ■ Equal percentage or ■ Modified equal percentage</p> <p>Standard Cage with Micro-Flute Valve Plug: (HPS and HPAS only): ■ Equal percentage or ■ Modified equal percentage</p>	<p>Standard Cage with Micro-Flat Valve Plug: (HPAS only): ■ Linear</p> <p>Cavitrol™ III, Whisper Trim™ III, or WhisperFlo™ Cage: ■ Linear</p> <p>Special cages: Special characterized flow cages are available. Consult your local Emerson sales office or Local Business Partner.</p> <p>Flow Direction</p> <p>Standard Cage</p> <ul style="list-style-type: none"> ■ <i>HPD and HPAD:</i> Normally flow down ■ <i>HPS and HPAS:</i> Normally flow up⁽⁵⁾ ■ <i>HPAS Micro-Flat:</i> Flow down ■ <i>HPT and HPAT:</i> Normally flow down ■ <i>HPS and HPAS Micro-Form:</i> Flow up only <p>Cavitrol III Cage: Flow down</p> <p>Whisper Trim III or WhisperFlo Cage: Flow up</p> <p>Approximate Weights (valve body and bonnet assemblies)</p> <p>See table 2</p> <p>Additional Specifications</p> <p>For specifications such as materials, valve plug travels, and port, yoke boss, and stem diameters, see the Parts List section</p>
--	--

1. EN (or other) ratings and end connections can usually be supplied; consult your Emerson sales office.
 2. CL900 and CL1500 globe valves are identical for NPS 1 and 2 valves. CL900 and CL1500 globe valves for NPS 3, 4, and 6 valves, however, are not identical.
 3. The centerline-to-face dimension for CL2500 NPS 1 and 2 HPA valves does not conform to ANSI/ISA 575.12.
 4. The pressure or temperature limits in this manual and any applicable standard limitations should not be exceeded.
 5. HPS and HPAS valves may be used flow down for on-off service only or where further limited by trim design. HPAS valves may be used flow down for erosive service.

Description

HP Series high-pressure globe and angle valves (figure 1) have metal seats, cage guiding, quick change trim, and push-down-to-close valve plug action. HPD, HPAD, HPT, and HPAT valves use balanced valve plugs. HPS and HPAS valves use an unbalanced valve plug. To provide a seal between the cage and a balanced valve plug, the HPD and HPAD valve plugs use piston rings; the HPT and HPAT valve plugs use a pressure-assisted seal ring. A Whisper Trim or WhisperFlo cage can be used with an HPD, HPAD, HPS, HPAS, HPT, or HPAT valve plug. A Cavitrol III cage can be used with an HPS, HPAS, HPT, or HPAT valve plug.

C-seal trim is available for HPD valves, CL900 and CL1500, in sizes NPS 3, 4, and 6; and for HPAD valves, CL900 and CL1500 in sizes NPS 4, 6, and 8.

With C-seal trim, a balanced valve can achieve high-temperature, Class V shutoff. Because the C-seal plug seal is formed from metal (N07718 nickel alloy) rather than an elastomer, a valve equipped with the C-seal trim can be applied in processes with a fluid temperature of up to 593°C (1100°F), provided other material limits are not exceeded.

Specifications

Specifications for the HP Series valves are shown in table 1.

Table 2. Approximate Weights (Valve and Bonnet Assemblies)

VALVE SIZE, NPS	PRESSURE RATING	KILOGRAMS		POUNDS	
		Flg	SWE & BWE	Flg	SWE & BWE
Globe Valves					
1	CL900 & CL1500	42	38	93	85
	CL2500	45	34	100	76
1-1/2 x 1	CL2500	---	34	---	76
2	CL900 & CL1500	72	52	158	115
	CL2500	104	74	229	164
3	CL900	125	---	276	---
	CL1500	129	97	284	213
4	CL900	230	---	507	---
	CL1500	249	201	548	444
6	CL900	511	---	1127	---
	CL1500	557	455	1228	1003
Angle Valves					
1	CL900 & CL1500	40	36	88	80
	CL2500	---	72 ⁽¹⁾	---	160 ⁽¹⁾
2	CL900 & CL1500	69	50	153	110
	CL2500	---	109 ⁽¹⁾	---	240 ⁽¹⁾
3	CL1500	123	78	278	173
4	CL1500	181	117	399	258
6	CL1500	357	202	788	445
8	CL1500	648	405	1428	893

1. Only SWE is available for CL2500.

Educational Services

For information on available courses for Fisher HP and HPA valves, as well as a variety of other products, contact:

Emerson Automation Solutions
 Educational Services - Registration
 Phone: 1-641-754-3771 or 1-800-338-8158
 E-mail: education@emerson.com
 emerson.com/fishervalvetraining

Installation

⚠ WARNING

Always wear protective gloves, clothing, and eyewear when performing any installation operations to avoid personal injury.

Personal injury or equipment damage caused by sudden release of pressure may result if the valve assembly is installed where service conditions could exceed the limits given in table 1 or on the appropriate nameplates. To avoid such injury or

damage, provide a relief valve for over-pressure protection as required by government or accepted industry codes and good engineering practices.

Check with your process or safety engineer for any additional measures that must be taken to protect against process media.

If installing into an existing application, also refer to the **WARNING** at the beginning of the Maintenance section in this instruction manual.

⚠ WARNING

Some bonnet flanges have a tapped hole that was used to handle the bonnet during manufacture. Do not use this tapped hole to lift the valve assembly or personal injury may result.

⚠ WARNING

When ordered, the valve configuration and construction materials were selected to meet particular pressure, temperature, pressure drop, and controlled fluid conditions indicated when the valve was ordered. Since some body/trim material combinations are limited in their pressure drop and temperature ranges, do not apply any other conditions to the valve without first contacting your [Emerson sales office](#) or Local Business Partner.

1. Before installing the valve, inspect it to ensure that the valve body cavity is free of foreign material.
2. Clean out all pipelines to remove scale, welding slag, and other foreign materials before installing the valve.

Note

If the valve body being installed has small internal flow passages, such as with Whisper Trim III, WhisperFlo, or Cavitrol III cages, consideration should be given to installing an upstream strainer to prevent the lodging of particles in these passages. This is especially important if the pipeline cannot be thoroughly cleaned or if the flowing medium is not clean.

3. Flow through the valve must be in the direction indicated by the flow arrow, which is stamped on or attached to the valve body.

Table 3. Shutoff Classifications per ANSI/FCI 70-2 and IEC 60534-4

VALVE DESIGN	PORT DIAMETER, mm (INCHES)	LEAKAGE CLASS
HPD, HPAD	47.6 (1.875) and smaller	II
	58.7 (2.3125) to 92.1 (3.625)	II - Standard
		III - Optional
	111.1 (4.375) and larger	III - Standard IV - Optional
HPS, HPAS w/ Cavitrol III, or HPT, HPAT w/ Cavitrol III, or HPAS w/Micro-Flat	All	V
HPS, HPAS, HPT, HPAT, HPS, HPAS w/ Micro-Form, or HPS, HPAS w/ Micro-Flute	All	IV-Standard
		V-Optional
HPT w/ PEEK anti-extrusion rings	47.6 (1.875) to 136.5 (5.375)	V - Standard

Table 4. Additional Shutoff Classification per ANSI/FCI 70-2 and IEC 60534-4

Valve Design	Valve Size, NPS		Port Diameter		Cage Style	Leakage Class
	HPD	HPAD	mm	Inches		
HPD, HPAD with optional C-seal trim	3	4	73.0	2.875	Equal Percentage, Modified Equal Percentage, Linear (std. cage), Linear (Whisper III, A1, B1)	V
	4	6	73.0	2.875	Linear (Whisper III, D3)	V
	4	6	92.1	3.625	Equal Percentage, Modified Equal Percentage, Linear (std. cage), Linear (Whisper III, A1, B3, C3)	V
	6	8	111.1	4.375	Linear (Whisper III, D3)	V
	6	8	136.5	5.375	Equal Percentage, Modified Equal Percentage, Linear (std. cage), Linear (Whisper III, A1, B3, C3)	V

Table 5. TSO (Tight Shutoff) Leakage Class per ANSI/FCI 70-2 and IEC 60534-4

Leakage Class	Maximum Leakage	Test Medium	Test Pressure	Leakage Class
TSO (Tight Shutoff)	Valves with TSO trim are factory tested to a more stringent Emerson Automation Solutions test requirement of no leakage at time of shipment.	Water	Service ΔP ⁽¹⁾	V

1. Specify service ΔP when ordering.

Table 6. TSO Shutoff Availability

VALVE DESIGN	CONSTRUCTION	LEAKAGE CLASS
HPS, HPT	Std or Cavitrol III trim. Replaceable, protected soft seat	TSO - Standard

Table 7. Recommended Torque for Packing Flange Nuts (Non Live-loaded Graphite Packing)

STEM DIAMETER		VALVE BODY RATING(1)	TORQUE			
mm	Inches		N•m		lbf•ft	
			Min	Max	Min	Max
12.7	1/2	CL900	12	18	9	13
12.7	1/2	CL1500	15	22	11	16
12.7	1/2	CL2500	18	24	13	18
19.1	3/4	CL900	27	41	20	30
19.1	3/4	CL1500	34	50	25	37
19.1	3/4	CL2500	41	61	30	45
25.4	1	CL900	42	62	31	46
25.4	1	CL1500	52	77	38	57
25.4	1	CL2500	61	91	45	67
31.8	1-1/4	CL900	56	83	41	61
31.8	1-1/4	CL1500	68	102	50	75

1. For intermediate class ratings, use the same torque as the next lower standard class.

CAUTION

Depending on valve body materials used, post-weld heat treating might be needed. Post-weld heat treatment can damage internal elastomeric, plastic, and metal parts. Shrink-fit pieces and threaded connections might also loosen. In general, if post-weld heat treating is needed, remove all trim parts. Contact your [Emerson sales office](#) or Local Business Partner for additional information.

4. Use accepted piping and welding practices when installing the valve in the pipeline. For flanged valve bodies, use a suitable gasket between the body and pipeline flanges.
5. Install a three-valve bypass around the valve if continuous operation is required during maintenance.
6. If the actuator and valve body are shipped separately, refer to the actuator mounting procedure in the appropriate actuator instruction manual.
7. If the valve body was shipped without packing installed in the packing box, install the packing before putting the valve body into service. Refer to instructions given in the Packing Maintenance procedure.

⚠ WARNING

Personal injury could result from packing leakage. Valve packing was tightened before shipment; however, the packing might require some readjustment to meet specific service conditions.

Valves with ENVIRO-SEAL™ live-loaded packing or HIGH-SEAL ULF live-loaded packing will not require this initial re-adjustment. See the instruction manuals titled ENVIRO-SEAL Packing System for Sliding-Stem Valves ([D101642X012](#)) or HIGH-SEAL ULF Live-Loaded Packing System ([D101453X012](#)) (as appropriate) for packing instructions. If you wish to convert your present packing arrangement to ENVIRO-SEAL packing, refer to the retrofit kits listed in the parts kit sub-section near the end of this manual.

Maintenance

Valve parts are subject to normal wear and must be inspected and replaced as necessary. Inspection and maintenance frequency depends on the severity of service conditions. This section includes instructions for packing lubrication, packing maintenance, and trim maintenance. All maintenance operations may be performed with the valve in the line.

⚠ WARNING

Avoid personal injury or damage to property from sudden release of pressure or uncontrolled process fluid. Before starting disassembly:

- Do not remove the actuator from the valve while the valve is still pressurized.
- Always wear protective gloves, clothing, and eyewear when performing any maintenance operations to avoid personal injury.
- Disconnect any operating lines providing air pressure, electric power, or a control signal to the actuator. Be sure the actuator cannot suddenly open or close the valve.
- Use bypass valves or completely shut off the process to isolate the valve from process pressure. Relieve process pressure on both sides of the valve. Drain the process media from both sides of the valve.
- Vent the power actuator loading pressure and relieve any actuator spring precompression.
- Use lock-out procedures to be sure that the above measures stay in effect while you work on the equipment.
- The valve packing box may contain process fluids that are pressurized, *even when the valve has been removed from the pipeline*. Process fluids may spray out under pressure when removing the packing hardware or packing rings, or when loosening the packing box pipe plug.
- Check with your process or safety engineer for any additional measures that must be taken to protect against process media.

Note

The HP series valve uses spiral-wound gaskets which are crushed to provide their seal. A spiral-wound gasket should never be reused. Whenever a gasket seal is disturbed by removing or shifting gasketed parts, a new gasket must be installed upon reassembly. This is necessary to ensure a good gasket seal, since the used gasket will not seal properly.

Table 8. Torque for Body-to-Bonnet Bolting Using Anti-Seize Lubricant⁽¹⁾

VALVE RATING	VALVE SIZE, NPS		TORQUE	
			N•m	lbf•ft
	HP	HPA	B7, B16, B8M CL2, BD, S20910, and 660 Studs	B7, B16, B8M CL2, BD, S20910, and 660 Studs
CL900 & CL1500	1	1	260	190
	2	2, 3	370	275
	3	4	710	525
	4	6	940	695
	6	8	1650	1220
CL2500	1	1	370	275
	2	2	710	525

1. For other materials, contact your [Emerson sales office](#) or Local Business Partner for torques.

CAUTION

The spiral-wound gaskets are of special design. Failure to use Fisher replacement parts may result in valve damage.

Figure 2. Lubricator and Lubricator/Isolating Valve

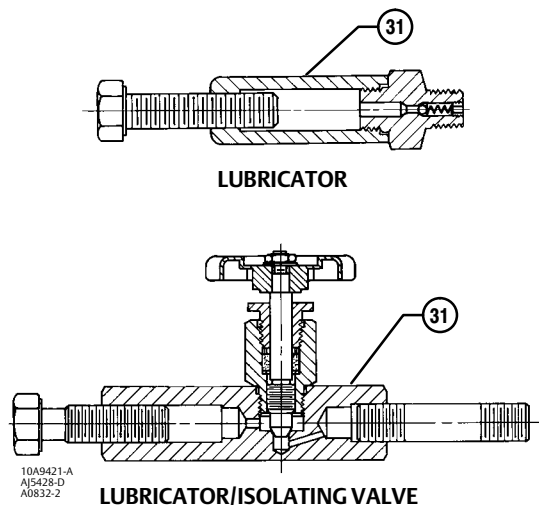

Note

If the valve has ENVIRO-SEAL live-loaded packing installed (figure 4), see the instruction manual entitled ENVIRO-SEAL Packing System for Sliding-Stem Valves ([D101642X012](#)) for packing instructions.

If the valve has HIGH-SEAL ULF live-loaded packing installed (figure 4), see the instruction manual entitled HIGH-SEAL ULF Live-Loaded Packing System ([D101453X012](#)) for packing instructions.

Packing Lubrication

CAUTION

Do not lubricate graphite packing. Graphite packing is self-lubricated. Additional lubrication may result in slip-stick movement of the valve.

Note

To avoid lubricants breaking down at elevated temperatures, do not lubricate packing used in processes with temperatures over 260°C (500°F).

⚠ WARNING

Do not lubricate parts when used in oxygen service, or where the lubrication is incompatible with the process media. Any use of lubricant can lead to the sudden explosion of media due to the oil/oxygen mixture, causing personal injury or property damage.

If a lubricator or lubricator/isolating valve (figure 2) is provided for PTFE/composition or other packings that require lubrication, it will be installed in place of the pipe plug (key 31, figure 17, 18, or 19). Use a good quality silicon-base lubricant. Packing used in oxygen service or in processes with temperatures over 260°C (500°F) should not be lubricated. To operate the lubricator, turn the cap screw clockwise to force the lubricant into the packing box. The lubricator/isolating valve operates the same way except the isolating valve must first be opened and then closed after lubrication is completed.

Packing Maintenance

If there is undesirable packing leakage in the spring-loaded PTFE V-ring packing shown in figure 3, tighten the packing flange nuts (key 21, figure 17, 18, or 19) until the shoulder on the packing follower (key 28, figure 17, 18, or 19) contacts the bonnet (key 18, figure 17, 18, or 19). If leakage continues, replace the packing by following the numbered steps presented in the replacing packing procedure.

If there is undesirable packing leakage with other than spring-loaded PTFE V-ring packing, first try to limit the leakage and establish a stem seal by tightening the packing flange nuts (key 21, figure 17, 18, or 19) to at least the minimum recommended torque in table 7. However, do not exceed the maximum recommended torque in table 7 or excessive friction may result. If leakage continues, replace the packing by following the numbered steps presented in the Replacing Packing procedure.

If the packing is relatively new and tight on the valve plug stem, and if tightening the packing flange nuts does not stop the leakage, it is possible that the stem is worn or nicked so that a seal cannot be made. The surface finish of a new stem is critical for making a good packing seal. If the leakage comes from the outside diameter of the packing, it is possible that the leakage is caused by nicks or scratches around the packing box wall. While replacing the packing according to the Replacing Packing procedure, inspect the valve plug stem and packing box wall for nicks or scratches.

Adding Packing Rings

Key numbers referred to in this procedure are shown in figure 17, 18, or 19, unless otherwise indicated.

When using packing with a lantern ring (key 24) it may be possible to add packing rings above the lantern ring as a temporary measure without removing the actuator from the valve body.

1. Isolate the control valve from the line pressure, release pressure from both sides of the valve body, and drain the process media from both sides of the valve. If using a power actuator, also shut-off all pressure lines to the power actuator, release all pressure from the actuator. Use lock-out procedures to be sure that the above measures stay in effect while you work on the equipment.
2. Remove the packing flange nuts (key 21) and lift the packing flange, upper wiper, and packing follower (keys 19, 27, and 28) away from the valve body.
3. It may be possible to dig out the old packing rings on top of the lantern ring, but use care to avoid scratching the valve plug stem or packing box wall. Clean all metal parts to remove particles that would prevent the packing from sealing.
4. Remove the stem connector and slip the packing rings over the end of the valve plug stem.
5. Reassemble the packing follower, upper wiper, packing flange, and packing flange nuts (keys 28, 27, 19, and 21).
6. Reconnect the body-actuator stem connection according to the appropriate actuator instruction manual.
7. Tighten the packing flange nuts only far enough to stop leakage under operating conditions. Check for leakage around the packing follower when the valve is being put into service. Retighten the packing flange nuts as required (see table 7).

Replacing Packing

▲ WARNING

Refer to the **WARNING** at the beginning of the Maintenance section in this instruction manual.

Key numbers referred to in this procedure are shown in figure 17, 18, or 19, unless otherwise indicated.

1. Isolate the control valve from the line pressure, release pressure from both sides of the valve body, and drain the process media from both sides of the valve. If using a power actuator, also shut-off all pressure lines to the power actuator, release all pressure from the actuator. Use lock-out procedures to be sure that the above measures stay in effect while you work on the equipment.
2. Remove the cap screws in the stem connector, and separate the two halves of the stem connector. Then exhaust all actuator pressure, if any was applied, and disconnect the actuator supply and any leakoff piping.
3. Remove either the yoke locknut (key 32) or the hex nuts (key 30), and remove the actuator from the bonnet (key 18).
4. Loosen the packing flange nuts (key 21) so that the packing (keys 22, 23, 209, or 210, figure 3) is not tight on the valve plug stem (key 6). Remove any travel indicator disk and stem locknuts from the valve plug stem threads.

CAUTION

When lifting the bonnet (key 18), be sure that the valve plug and stem assembly (keys 5 and 6) remains on the seat ring (key 4). This avoids damage to the seating surfaces as a result of the assembly dropping from the bonnet after being lifted part way out. The parts are also easier to handle separately.

Use care to avoid damaging gasket sealing surfaces.

The HPD and HPAD piston rings (key 8) are brittle and in two pieces. Avoid damaging the piston rings by dropping or rough handling.

Figure 3. Packing Arrangements

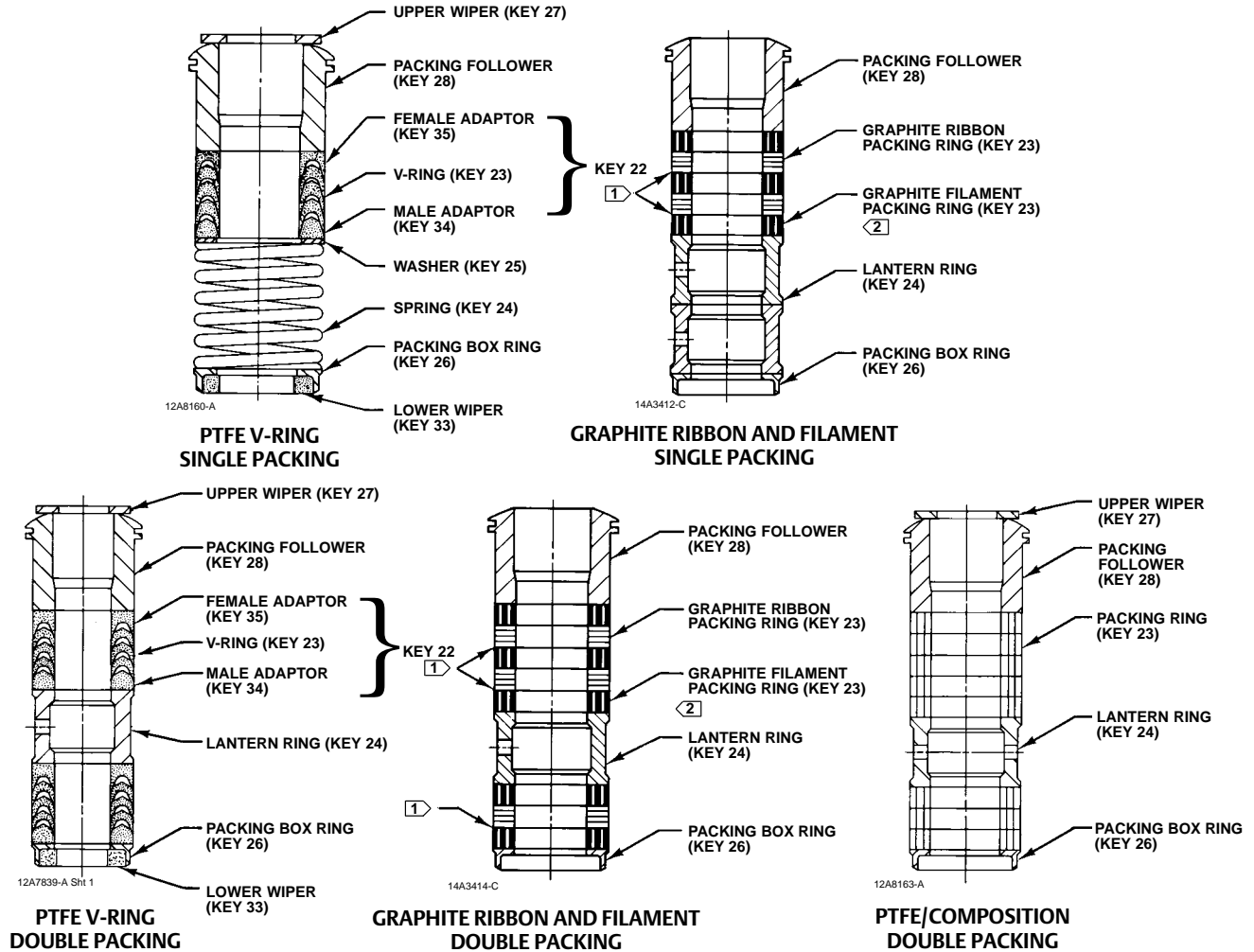

- NOTES:
- 1 0.102 mm (0.004 INCH) THICK SACRIFICIAL ZINC WASHERS. USE ONLY ONE BELOW EACH GRAPHITE RIBBON RING.
 - 2 HAS THE APPEARANCE OF A WOVEN OR BRAIDED RING.

C0747-1

⚠ WARNING

To avoid personal injury or property damage caused by uncontrolled movement of the bonnet, loosen the bonnet by following the instructions in the next step. Do not remove a stuck bonnet by pulling on it with equipment that can stretch or store energy in any other manner. The sudden release of stored energy can cause uncontrolled movement of the bonnet. If the cage sticks to the bonnet, proceed carefully with bonnet removal and support the cage so that it will not fall unexpectedly from the bonnet.

Figure 4. Live-Loaded Packing

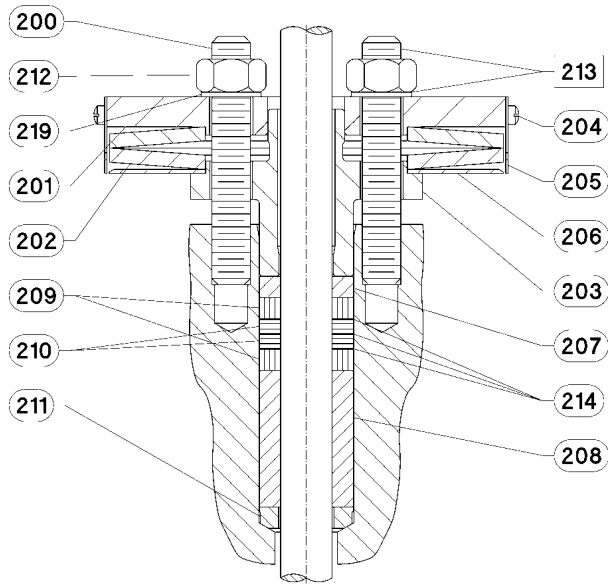

39B4153-A

Typical HIGH-SEAL Graphite ULF Packing System

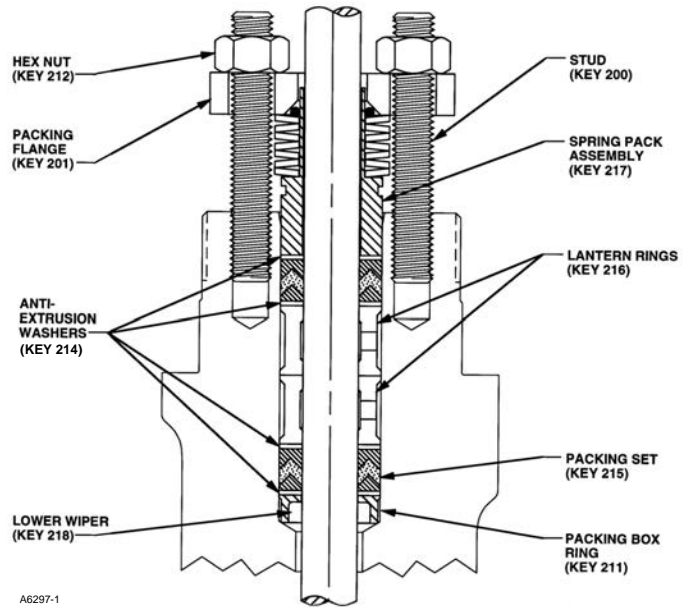

A6297-1

Typical ENVIRO-SEAL Packing System with PTFE Packing

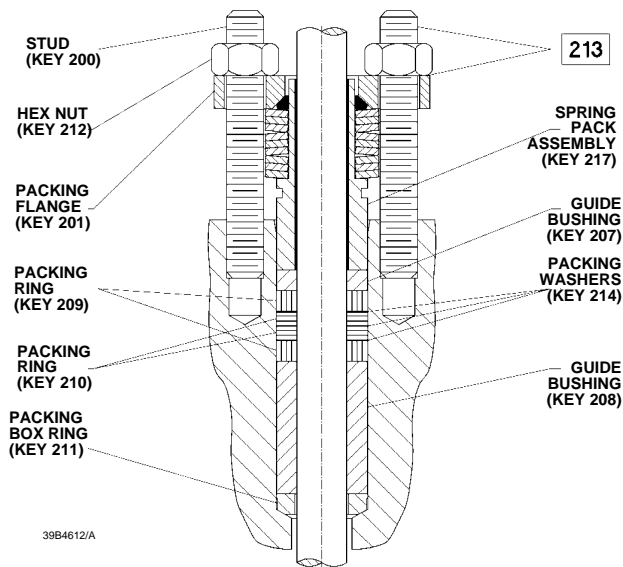

39B4612/A

Typical ENVIRO-SEAL Packing System with Graphite ULF Packing

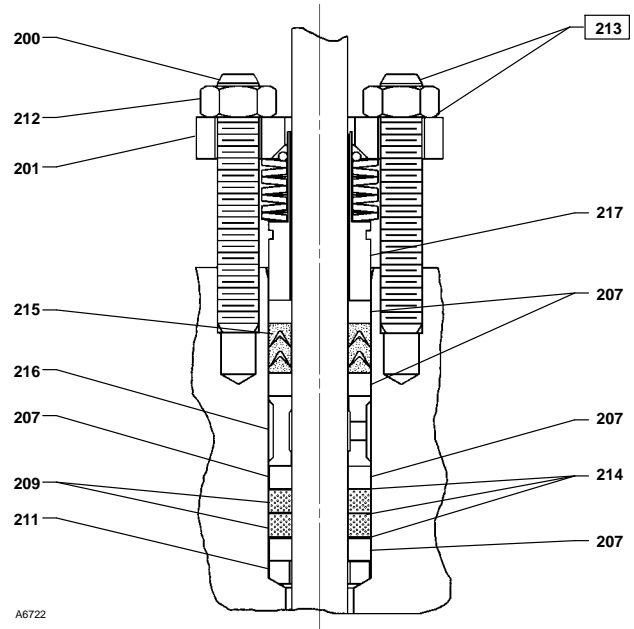

A6722

Typical ENVIRO-SEAL Packing System with Duplex Packing

Note

The following step also provides additional assurance that the valve body fluid pressure has been relieved.

5. Hex nuts (key 14) attach the bonnet to the valve body. Loosen these nuts or cap screws approximately 3 mm (1/8 inch). Then loosen the body-to-bonnet gasketed joint by either rocking the bonnet or prying between the bonnet and valve body. Work the prying tool around the bonnet until the bonnet loosens. If no fluid leaks from the joint, proceed to the next step.
6. Unscrew the hex nuts (key 14) and carefully lift the bonnet off the valve stem. If the valve plug and stem assembly starts to lift with the bonnet, use a brass or lead hammer on the end of the stem and tap it back down. Set the bonnet on a cardboard or wooden surface to prevent damage to the bonnet gasket surface.
7. Remove the valve plug (key 5), bonnet gasket (key 11), cage (key 2), seat ring (key 4), and the seat ring gasket (key 12).

CAUTION

Inspect the seat ring, cage, bonnet, and body gasket surfaces. These surfaces must be in good condition, with all foreign material removed. Small burrs less than approximately 0.076 mm (0.003 inches) in height (the thickness of a human hair) can be ignored. Scratches or burrs that run across the serrations are not permitted under any conditions, since they will prevent the gaskets from sealing properly.

8. Clean all gasket surfaces with a good wire brush. Clean in the same direction as the surface serrations, not across them.
9. Cover the opening in the valve body to protect the gasket surface and to prevent foreign material from getting into the valve body cavity.
10. Remove the packing flange nuts (key 21), packing flange (key 19), upper wiper (key 27), and packing follower (key 28). Carefully push out all the remaining packing parts from the valve side of the bonnet using a rounded rod or other tool that will not scratch the packing box wall. For extension bonnets, also remove the baffle (key 36) and retaining ring (key 37).
11. Clean the packing box and the following metal packing parts: packing follower, packing box ring (key 26), spring or lantern ring (key 24), and, for single arrangements of PTFE V-ring packing only, special washer (key 25).
12. Inspect the valve stem threads for any sharp edges that might cut the packing. A whetstone or emery cloth may be used to smooth the threads if necessary.
13. Remove the protective covering from the valve body cavity, and install the seat ring and cage using a new seat ring gasket (key 12) and bonnet gasket (key 11). Install the plug, then slide the bonnet over the stem and onto the studs (key 13). For a valve body with extension bonnet, also install the baffle and retaining rings (keys 36 and 37).

Note

The prelubricated hex nuts (key 14) referred to in step 14 can be identified by a black film coating on the nut threads.

The proper bolting procedures in step 14 include--but are not limited to--ensuring that the bonnet stud threads are clean, and that the hex nuts are evenly tightened to the specified torque values.

Table 9. Valve Stem Connection Torque and Drill Size for Pin Hole

VALVE SIZE, NPS		VALVE STEM DIAMETER		DESIGN	VALVE STEM CONNECTION TORQUE (MINIMUM-MAXIMUM)		DRILL SIZE FOR PIN
HP	HPA	mm	Inches		N•m	Lbf•ft	Inches
1	1	12.7	1/2	HPS, HPAS	81 - 115	60 - 85	1/8
		19.1	3/4	HPS, HPAS	237 - 339	175 - 250	3/16
2	2, 3	12.7	1/2	HPD, HPAD, HPS, HPAS ⁽¹⁾ , HPT, HPAT	81 - 115	60 - 85	1/8
		19.1	3/4	HPS, HPAS ⁽¹⁾	237 - 339	175 - 250	3/16
				HPD, HPAD, HPT, HPAT	237 - 339	175 - 250	1/8
		25.4	1	HPS, HPAS ⁽¹⁾	420 - 481	310 - 355	1/4
3	4	12.7	1/2	HPD, HPS, HPT, HPAD, HPAT	81 - 115	60 - 85	1/8
		19.1	3/4	HPD, HPS, HPT, HPAD, HPAT	237 - 339	175 - 250	3/16
		25.4	1	HPD, HPS, HPT, HPAD, HPAT	420 - 481	310 - 355	1/4
4	6	19.1	3/4	HPD, HPT, HPAD, HPAT	237 - 339	175 - 250	3/16
		25.4	1	HPD, HPT, HPAD, HPAT	420 - 481	310 - 355	1/4
6	8	19.1	3/4	HPD, HPT, HPAD, HPAT	237 - 339	175 - 250	3/16
		25.4	1	HPD, HPT, HPAD, HPAT	420 - 481	310 - 355	1/4
		31.8	1-1/4	HPD, HPT, HPAD, HPAT	827 - 908	610 - 670	1/4

1. HPAS available in NPS2 only.

CAUTION

Failure to comply with good bonnet-to-body bolting practices and the torque values shown in table 8 may result in damage to the valve. Cheater bars or slug wrenches should not be used for this procedure.

Hot torquing is not recommended.

Note

Stud(s) and nut(s) should be installed such that the manufacturer's trademark and material grade marking is visible, allowing easy comparison to the materials selected and documented in the Emerson/Fisher serial card provided with this product.

⚠ WARNING

Personal injury or damage to equipment could occur if improper stud and nut materials or parts are used. Do not operate or assemble this product with stud(s) and nut(s) that are not approved by Emerson/Fisher engineering and/or listed on the serial card provided with this product. Use of unapproved materials and parts could lead to stresses exceeding the design or code limits intended for this particular service. Install studs with the material grade and manufacturer's identification mark visible. Contact your [Emerson sales office](#) or Local Business Partner immediately if a discrepancy between actual parts and approved parts is suspected.

- Lubricate the stud threads and the faces of the hex nuts (key 14) with anti-seize lubricant (not necessary if new factory prelubricated hex nuts are used). Replace the hex nuts and tighten them finger-tight. Stroke the valve several times to center the trim. Torque the nuts in a crisscross pattern to no more than 1/4 of the nominal torque value specified in table 8.

When all nuts are tightened to that torque value, increase the torque by 1/4 of the specified nominal torque and repeat the crisscross pattern. Repeat this procedure until all nuts are tightened to the specified nominal value. Apply the final torque value again and, if any nut still turns, tighten every nut again.

Note

When installing packing rings, prevent entrapping air between the rings. Add the rings one at a time without forcing them below the chamfer of the packing box entrance chamber. As each successive ring is added, the stack should not be pushed down more than the thickness of the added ring (figure 5).

15. Install new packing and the metal packing box parts according to the appropriate arrangement in figure 3. If desired, packing parts may be pre-lubricated with a silicon base grease for easier installation. Slip a smooth-edged pipe over the valve stem, and gently tamp each soft packing part into the packing box, being sure that air is not trapped between adjacent soft parts.
16. Slide the packing follower, wiper, and packing flange into position. Lubricate the packing flange studs (key 20) and the faces of the packing flange nuts (key 21). Replace the packing flange nuts.

For the spring-loaded PTFE V-ring packing shown in figure 3, tighten the packing flange nuts until the shoulder on the packing follower (key 28) contacts the bonnet.

Figure 5. Installing Graphite Ribbon/Filament Packing Rings One at a Time

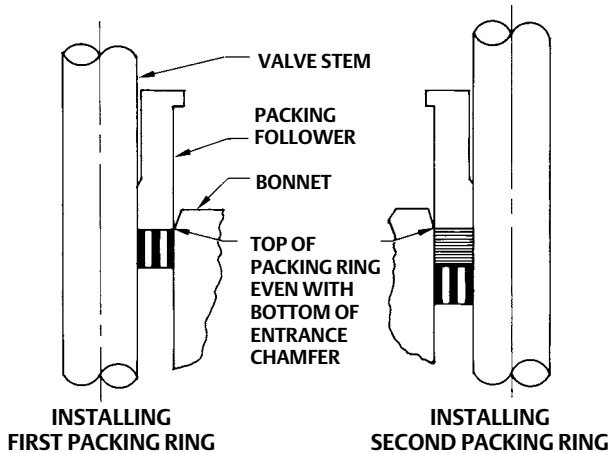

A2207-2

For **graphite packing**, tighten the packing flange nuts to the maximum recommended torque shown in table 7. Then, loosen the packing flange nuts, and retighten them to the recommended minimum torque shown in table 7.

For **other packing types**, tighten the packing flange nuts alternately in small equal increments until one of the nuts reaches the minimum recommended torque shown in table 7. Then, tighten the remaining flange nuts until the packing flange is level and at a 90-degree angle to the valve stem.

For **ENVIRO-SEAL or HIGH-SEAL live-loaded packing**, refer to the note at the beginning of the Maintenance section.

17. Mount the actuator on the valve body assembly, and reconnect the actuator and valve plug stems according to the procedures in the appropriate actuator instruction manual.

Trim Removal

For C-seal construction, see the appropriate C-seal sections in this manual.

Key numbers referenced in this procedure are shown in figure 17, 18, or 19, except where indicated.

1. Remove the actuator and bonnet by following steps 1 through 6 of the replacing packing procedure. Observe all warnings and cautions.
2. Lift the valve stem and attached valve plug out of the valve body. If the valve plug is to be reused, tape or otherwise protect the valve plug stem and the valve plug seating surface to prevent scratches.
3. Lift out the cage (key 2) and the bonnet gasket (key 11). For an NPS 2 valve body with a Cavitrol III two stage cage, also remove the bonnet spacer and two gaskets.

Constructions other than TSO trim

1. Remove the seat ring (key 4) and the seat ring gasket (key 12).
2. Refer to the Valve Plug Maintenance procedure or to the Lapping Seats procedure.

TSO Trim

TSO trim: 0.8125 Inch Port Diameter (figure 7)

1. Remove the pin that locks the inner plug to the stem.
2. Using a strap wrench or similar tool, unscrew the outer plug from the inner plug. Do not damage the outer plug guide surfaces.
3. Remove the protected soft seat seal.
4. Inspect the parts for damage and replace if needed.
5. Refer to the Valve Plug Maintenance procedure or to the Lapping Seats procedure.

TSO trim: 1.6875 Inch Port Diameter (figure 8)

1. Remove the retainer, backup ring, anti-extrusion rings, and piston ring.
2. Remove the set screws that lock the outer plug to the stem.
3. Using a strap wrench or similar tool, unscrew the outer plug from the inner plug. Do not damage the outer plug guide surfaces.
4. Remove the protected soft seat seal.
5. Inspect the parts for damage and replace if needed.
6. Refer to the Valve Plug Maintenance procedure or to the Lapping Seats procedure.

TSO trim: 2.6875 Inch and Larger Port Diameters (figure 9)

1. Remove the retainer, backup ring, anti-extrusion rings, and piston ring.
2. Remove the set screws that lock the outer plug to the inner plug.
3. Using a strap wrench or similar tool, unscrew the outer plug from the inner plug. Do not damage the outer plug guide surfaces.
4. Remove the protected soft seat seal.
5. Inspect the parts for damage and replace if needed.
6. Refer to the Valve Plug Maintenance procedure or to the Lapping Seats procedure.

Valve Plug Maintenance

Key numbers used in this procedure are shown in figure 17, 18, or 19, except where indicated.

1. With the valve plug (key 5) removed according to the trim removal procedure, proceed as appropriate:

For HPD and HPAD valves, the piston rings (key 8) are each in at least two sections; remove the sections from the grooves in the valve plug.

For HPS and HPAS valves, proceed to step 2.

For HPT and HPAT valves, work the retaining ring (key 10) off the valve plug with a screwdriver. Carefully slide the backup ring and seal ring (keys 9 and 8) off the valve plug.

2. To replace the valve plug stem (key 6), drive out the pin (key 7), and unscrew the stem from the valve plug.

CAUTION

Never reuse an old stem with a new valve plug. Using an old stem with a new plug requires drilling a new pin hole in the stem. This weakens the stem and may cause the stem to fail in service. If a new valve plug is required, always order a valve plug, stem, and pin as an assembly. Specify the correct part number of each of the three parts, but state that the parts are being ordered as an assembly.

A used valve plug may be reused with a new stem.

Figure 6. Detail of Protected Soft Seat

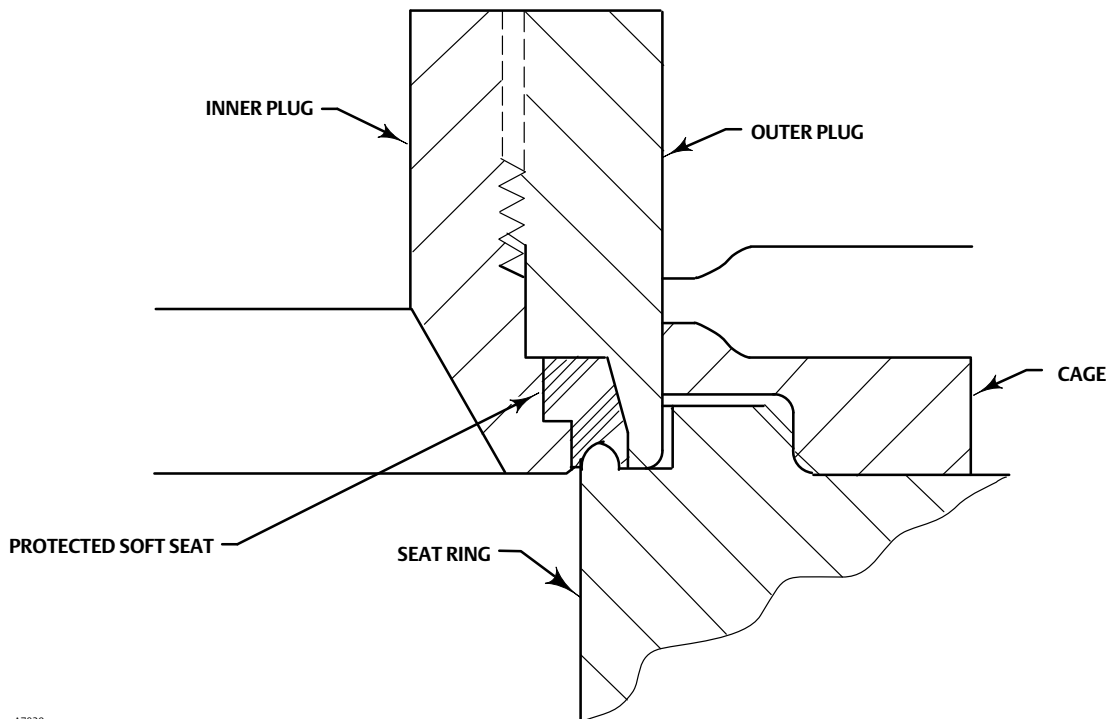

A7039

3. Thread the new stem into the valve plug and tighten it to the appropriate torque value given in table 9. Using the valve plug pin hole as a guide, drill the pin hole through the stem. Refer to table 9 for drill sizes.
4. Drive in the pin to lock the assembly.
5. If it is necessary to lap the seating surfaces, complete the lapping seats procedure before installing the HPD/HPAD piston rings or the HPT/HPAT seal ring. The Trim Replacement procedure provides piston ring and seal ring installation instructions and valve reassembly instructions.

Lapping Seats

Key numbers referenced in this procedure are shown in figure 17, 18, or 19, except where indicated.

A certain amount of leakage should be expected with metal-to-metal seating in any valve body. If the leakage becomes excessive, however, the condition of the seating surfaces of the valve plug and seat ring can be improved by lapping. (Deep nicks should be machined out rather than ground out.) Use a good quality lapping compound of a mixture of 280 to 600-grit. Apply the compound to the bottom of the valve plug.

Figure 7. Typical Unbalanced TSO Trim Assembly, Small Port Designs (0.8125 Inch Port Diameter)

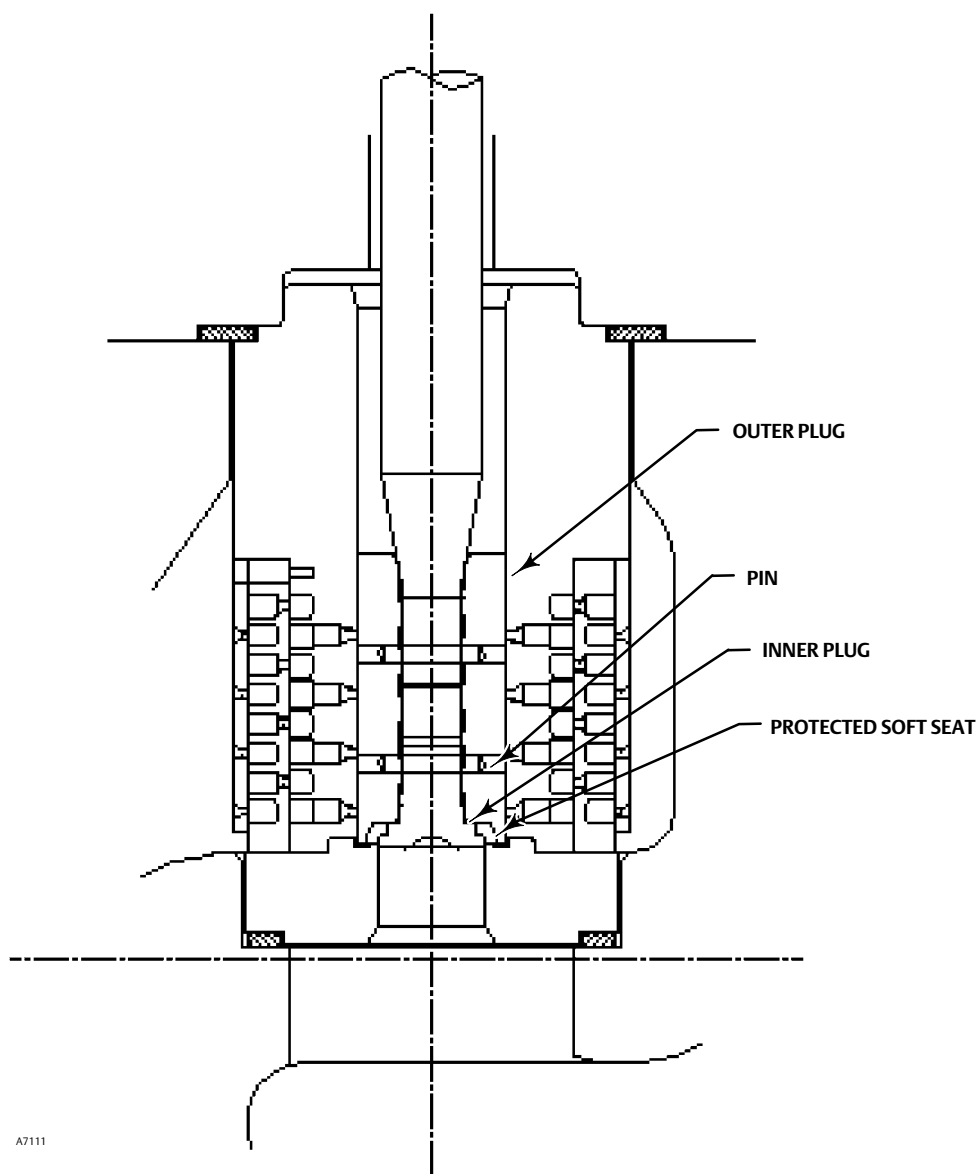

A7111

Note

HP Series valves use spiral-wound gaskets. These gaskets provide their seal by being crushed and therefore should never be reused. This includes reusing a gasket after the lapping procedure has been performed.

And "old" gasket can be used to lap the seat, however the gasket must be replaced with a new gasket.

To preserve the effects of lapping, do not change either the position of the seat ring in the valve body cavity or the position of the cage on the seat ring after lapping the seating surfaces. When the parts are removed for cleaning and replacement of the "old" gaskets, return them to the original positions.

Figure 8. Typical Balanced TSO Trim (1.6875 Inch Port Diameter)

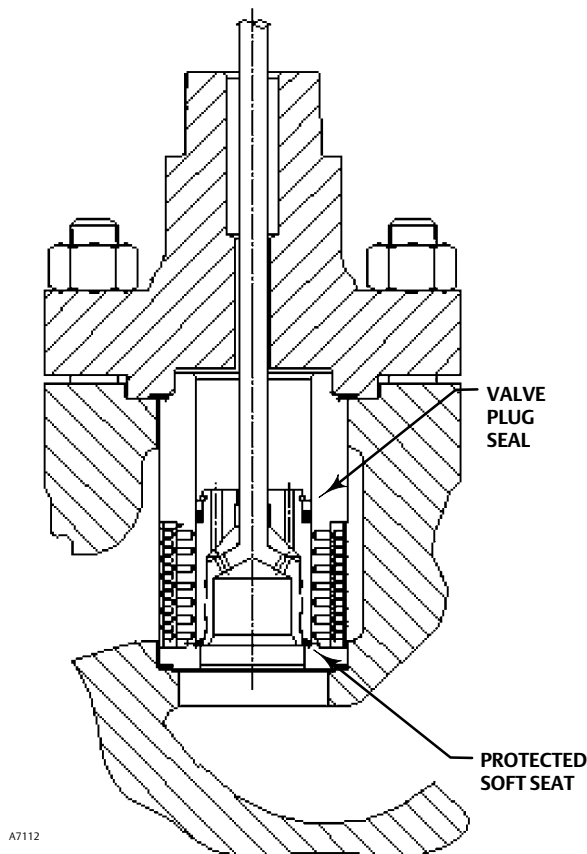

A7112

Use the following procedure to lap the seating surfaces.

1. Install the following parts according to the instructions presented in the trim replacement procedure: "old" seat ring gasket (key 12), seat ring (key 4), cage (key 2), and "old" bonnet gasket(key 11).
2. Proceed as appropriate:

For an HPD, HPAD, HPT, or HPAT valve, install the valve plug and stem assembly (keys 5 and 6)--without piston rings or seal ring (key 8) --into the cage.

For an HPS or HPAS valve, install the valve plug and stem assembly (keys 5 and 6) into the cage.

3. Install the bonnet (key 18) over the valve stem, and secure the bonnet with four of the hex nuts (key 14).

Figure 9. Typical Balanced TSO Trim, Large Port Designs (2.6875 Inch and Larger Port Diameters)

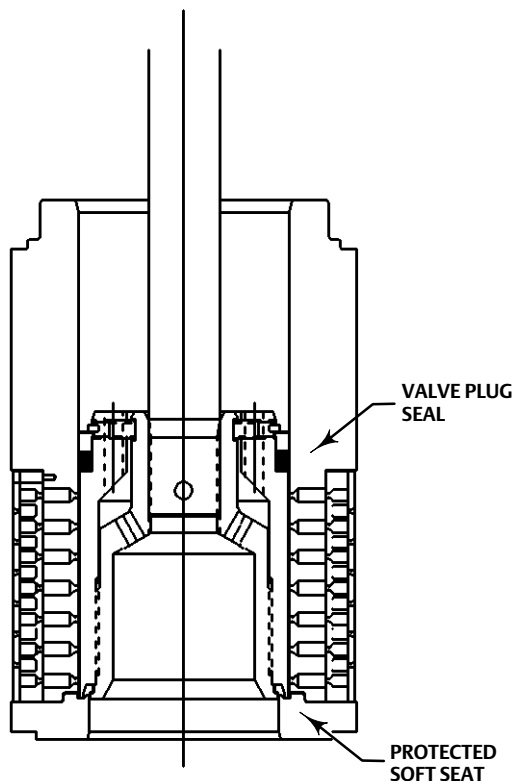

A7096

Table 10. Actuator Groups by Type Number

Group 1 71 & 90 mm (2-13/16 & 3-9/16 Inch) Yoke Boss	Group 100 127 mm (5-Inch) Yoke Boss
472 & 473 585C 1B 644 & 645 655 657 & 667 685SE & 685SR 1008	472 473 474 476 585C 657
	Group 101 127 mm (5-Inch) Yoke Boss
	667

4. Attach a handle, such as a piece of strap iron secured by stem locknuts, to the valve stem. Rotate the handle alternately in each direction to lap the seats.
5. After lapping, disassemble as necessary (you may mark the position of the seat ring and cage with a soft tip marker). Clean the seating surfaces, replace the gaskets, reassemble (taking care to return the seat ring and cage to their original positions), and test for shutoff. Repeat the lapping procedure if necessary.

Trim Replacement

⚠ WARNING

Observe the warning at the start of the Maintenance section.

After all trim maintenance has been completed, reassemble the valve body by following the numbered steps below. Be certain that all gasketed surfaces have been well cleaned. Key numbers referenced in this procedure are shown in figure 17, 18, or 19, except where indicated.

CAUTION

Inspect the seat ring, cage, bonnet, and body gasket surfaces. These surfaces must be in good condition, with all foreign material removed. Small burrs less than approximately 0.076 mm (0.003 inches) in height (the thickness of a human hair) can be ignored. Scratches or burrs that run across the serrations are not permitted under any conditions, since they will prevent the gaskets from sealing properly.

CAUTION

The pressure balancing holes in the valve plug are necessary for the proper and safe operation of the valve. Inspect the balancing holes every time the valve is disassembled for service. Any build-up, blockage, or clogging of the balance holes should be removed.

1. Install the seat ring gasket (key 12) into the valve body. Install the seat ring (key 4).
2. Install the cage.

Note

When installing the standard cage, align two of the holes in the cage with the centerline of the valve body. Refer to figure 18.

Constructions other than TSO trim

1. To install the piston rings and seal rings (key 8), proceed as appropriate:

For an HPD or HPAD valve, if it is necessary to install new piston rings, the replacement piston rings will arrive in one piece. Use a vise with smooth or taped jaws to break a replacement piston ring into halves. Place the new ring in the vise so that the jaws compress the ring into an oval. Compress the ring slowly until the ring snaps on both sides. If one side snaps first, do not try to tear or cut the other side. Instead, keep compressing until the other side snaps. The piston ring can also be fractured by scoring and snapping over a hard surface such as a table edge. Sawing or cutting is not recommended.

Remove any protective tape or covering from the valve plug and stem assembly, and set it on a protective surface. Then, place the piston rings in the piston ring grooves with the fractured ends matched.

For an HPT or HPAT valve, install the seal ring (key 8) onto the valve plug (key 5). Install the ring with the open side facing the seat ring end of the valve plug for flow-down applications (view A of figure 20) or with the open side facing

the valve plug stem end of the valve plug for flow-up applications (view B of figure 20). Slide the backup ring (key 9) onto the valve plug. Secure with the retaining ring (key 10).

For an HPAS Micro-Flat valve, ensure the Micro-Flat valve plug and stem assembly is oriented as shown in figure 10 when replacing the bonnet on the valve body. Then slide the bonnet over the stem and onto the stud bolts.

CAUTION

Micro-flat plugs must be installed as shown in figures 10 and 18. This proper plug orientation increases the guide support area for the plug and stem.

Figure 10. Micro-Flat Valve Plug Orientation

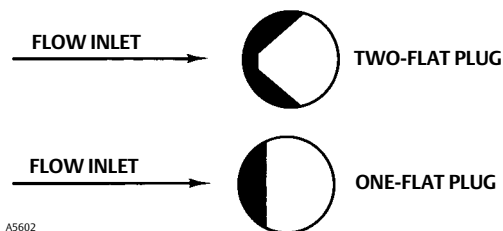

2. Install the valve plug into the cage.

TSO Trim

TSO trim: 0.8125 Inch Port Diameter (figure 7)

1. Thread the outer plug onto the inner plug until the parts seat metal to metal, using a strap wrench or similar tool that will not damage the outer plug guide surfaces.
2. Mark the inner plug and outer plug with alignment marks in the assembled position.
3. Disassemble the outer plug from the inner plug and install the seal over the inner plug, so that the seal rests below the threaded area.
4. Thread the outer plug onto the inner plug and tighten with a strap wrench or similar tool until the alignment marks line up. This will ensure that the plug parts are metal to metal and the seal is compressed properly. Do not damage the outer plug guide surfaces.
5. Drill through the inner plug with the proper size drill bit (same size as stem pinning) and install the pin.

TSO trim: 1.6875 Inch Port Diameter (figure 8)

1. Thread the outer plug onto the inner plug until the parts seat metal to metal, using a strap wrench or similar tool that will not damage the outer plug guide surfaces.
2. Mark the top of the outer plug and stem with alignment marks in the assembled position.
3. Disassemble the outer plug from the inner plug and install the seal over the inner plug, so that the seal rests below the threaded area.
4. Thread the outer plug onto the inner plug and tighten with a strap wrench or similar tool until the alignment marks line up. This will ensure that the plug parts are metal to metal and the seal is compressed properly. Do not damage the outer plug guide surfaces.
5. Install set screws centering the stem in the outer plug and torque to 11 N•m (8 lbf•ft).
6. Assemble the piston ring, anti-extrusion rings, backup ring, and retainer.

TSO trim: 2.6875 Inch and Larger Port Diameters (figure 9)

1. Thread the outer plug onto the inner plug until the parts seat metal to metal, using a strap wrench or similar tool that will not damage the outer plug guide surfaces.

2. Mark the top of the inner plug and outer plug with alignment marks in the assembled position.
3. Disassemble the outer plug from the inner plug and install the seal over the inner plug, so that the seal rests below the threaded area.
4. Thread the outer plug onto the inner plug and tighten with a strap wrench or similar tool until the alignment marks line up. This will ensure that the plug parts are metal to metal and the seal is compressed properly. Do not damage the outer plug guide surfaces.
5. Install set screws centering the inner plug in the outer plug and torque to 11 N•m (8 lbf•ft).
6. Assemble the piston ring, anti-extrusion rings, backup ring, and retainer.

All Constructions

1. Install the bonnet gasket (key 11) on the cage.
2. Install the bonnet over the valve stem and onto the valve body.

Note

The prelubricated hex nuts (key 14) referred to in step 3 can be identified by a black film coating on the nut threads.

The proper bolting procedures in step 3 include--but are not limited to--ensuring that the bonnet stud threads are clean, and that the hex nuts are evenly tightened to the specified torque values.

Figure 11. HPD with C-seal Trim

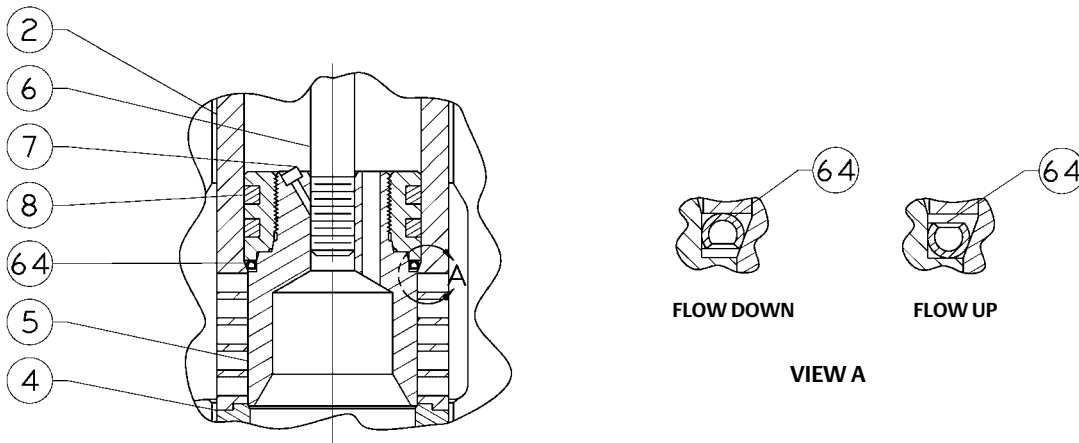

3781399-A

CAUTION

Failure to comply with good bonnet-to-body bolting practices and the torque values shown in table 8 may result in damage to the valve. Cheater bars or slug wrenches should not be used for this procedure.

Hot torquing is not recommended.

Note

Stud(s) and nut(s) should be installed such that the manufacturer's trademark and material grade marking is visible, allowing easy comparison to the materials selected and documented in the Emerson/Fisher serial card provided with this product.

FOR VALVE PLUGS FITTING PORT SIZE (Inches)	DIMENSIONS, mm (See Drawing Below)								Part Number (To Order A Tool)
	A	B	C	D	E	F	G	H	
2.875	82.55	52.324 - 52.578	4.978 - 5.029	3.708 - 3.759	41.148	52.680 - 52.781	55.118 - 55.626	70.891 - 71.044	24B9816X012
3.4375	101.6	58.674 - 58.928	4.978 - 5.029	3.708 - 3.759	50.8	61.011 - 61.112	63.449 - 63.957	85.166 - 85.319	24B5612X012
3.625	104.394	65.024 - 65.278	4.978 - 5.029	3.708 - 3.759	50.8	68.936 - 69.037	71.374 - 71.882	89.941 - 90.094	24B3630X012
4.375	125.984	83.439 - 83.693	4.978 - 5.029	3.708 - 3.759	50.8	87.351 - 87.452	89.789 - 90.297	108.991 - 109.144	24B3635X012
5.375	142.748	100.076 - 100.33	4.978 - 5.029	3.708 - 3.759	45.974	103.835 - 103.937	106.274 - 106.782	128.219 - 128.372	23B9193X012
FOR VALVE PLUGS FITTING PORT SIZE (Inches)	Dimensions, Inches (See Drawing Below)								Part Number (To Order A Tool)
	A	B	C	D	E	F	G	H	
2.875	3.25	2.060 - 2.070	0.196 - 0.198	0.146 - 0.148	1.62	2.074 - 2.078	2.170 - 2.190	2.791 - 2.797	24B9816X012
3.4375	4.00	2.310 - 2.320	0.196 - 0.198	0.146 - 0.148	2.00	2.402 - 2.406	2.498 - 2.518	3.353 - 3.359	24B5612X012
3.625	4.11	2.560 - 2.570	0.196 - 0.198	0.146 - 0.148	2.00	2.714 - 2.718	2.810 - 2.830	3.541 - 3.547	24B3630X012
4.375	4.96	3.285 - 3.295	0.196 - 0.198	0.146 - 0.148	2.00	3.439 - 3.443	3.535 - 3.555	4.291 - 4.297	24B3635X012
5.375	5.62	3.940 - 3.950	0.196 - 0.198	0.146 - 0.148	1.81	4.088 - 4.092	4.184 - 4.204	5.048 - 5.054	23B9193X012

Figure 12. C-seal Plug Seal Installation Tool

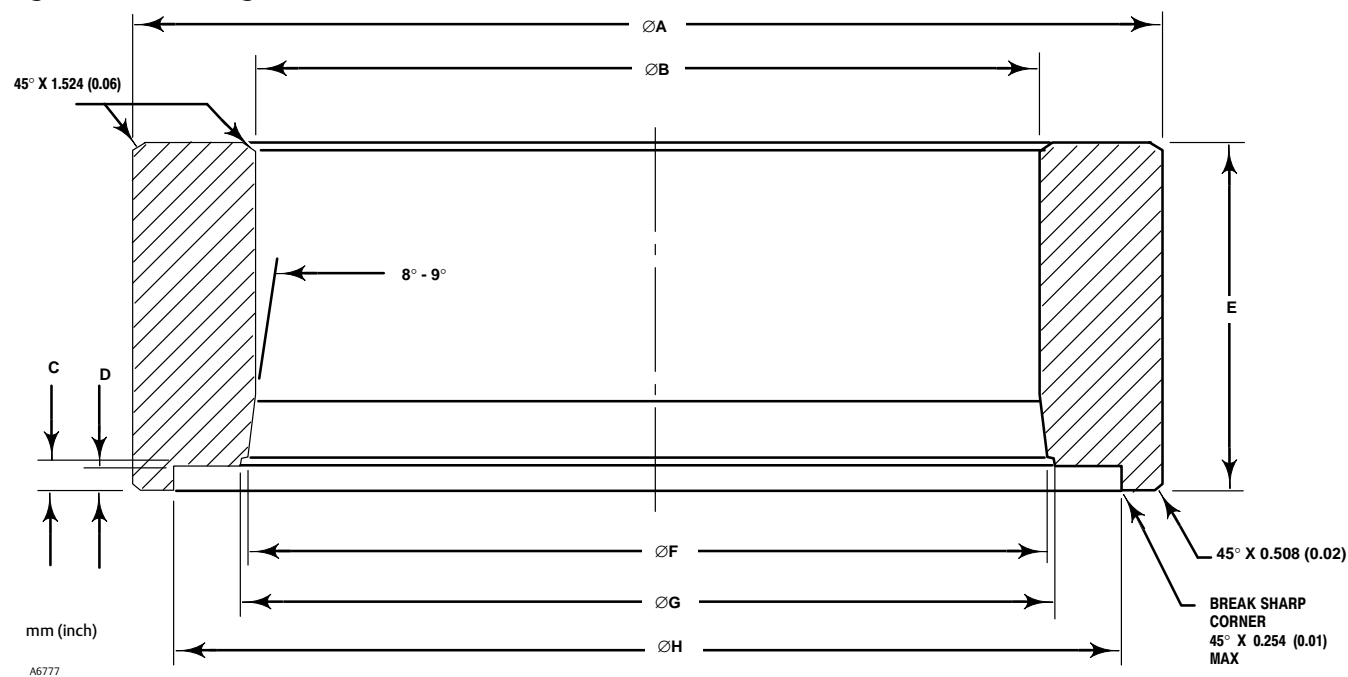

⚠ WARNING

Personal injury or damage to equipment could occur if improper stud and nut materials or parts are used. Do not operate or assemble this product with stud(s) and nut(s) that are not approved by Emerson/Fisher engineering and/or listed on the serial card provided with this product. Use of unapproved materials and parts could lead to stresses exceeding the design or code limits intended for this particular service. Install studs with the material grade and manufacturer's identification mark visible. Contact your [Emerson sales office](#) or Local Business Partner immediately if a discrepancy between actual parts and approved parts is suspected.

3. Lubricate the stud threads and the faces of the hex nuts (key 14) with anti-seize lubricant (not necessary if new factory prelubricated hex nuts are used). Replace the hex nuts, but do not tighten them. Torque the nuts in a crisscross pattern to no more than 1/4 of the nominal torque value specified in table 8. When all nuts are tightened to that torque value, increase the torque by 1/4 of the specified nominal torque and repeat the crisscross pattern. Repeat this procedure until all nuts are tightened to the specified nominal value. Apply the final torque value again and, if any nut still turns, tighten every nut again.
4. Install new packing and packing box parts per steps 15 and 16 of the Replacing Packing procedure. Be certain to observe the note given prior to step 15 of that procedure.
5. Mount the actuator by following the procedures in the actuator instruction manual. Check for packing leakage as the valve is being put into service. Retorque the packing flange nuts as required (see table 7).

Retrofit: Installing C-seal Trim

Note

Additional actuator thrust is required for a valve with C-seal trim. When installing C-seal trim in an existing valve, contact your [Emerson sales office](#) or Local Business Partner for assistance in determining new actuator thrust requirements.

Assemble the new valve plug/retainer assembly (with C-seal plug seal) using the following instructions:

CAUTION

To avoid leakage when the valve is returned to service, use appropriate methods and materials to protect all sealing surfaces of the new trim parts while assembling the individual parts and during installation in the valve body.

1. Apply a suitable high-temperature lubricant to the inside diameter of the C-seal plug seal. Also, lubricate the outside diameter of the valve plug where the C-seal plug seal must be pressed into the proper sealing position (figure 11).
2. Orient the C-seal plug seal for correct sealing action based on the process fluid flow direction through the valve.
 - The open interior of the C-seal plug seal must face up in a valve with flow-up construction (figure 11).
 - The open interior of the C-seal plug seal must face down in a valve with flow-down construction (figure 11).

Note

An installation tool must be used to properly position the C-seal plug seal on the valve plug. A tool is available as a Fisher spare part or a tool could be manufactured following the dimensions given in figure 12.

3. Place the C-seal plug seal over the top of the valve plug and press the C-seal plug seal onto the plug using the C-seal installation tool. Carefully press the C-seal plug seal onto the plug until the installation tool contacts the horizontal reference surface of the valve plug (figure 13).
4. Apply a suitable high-temperature lubricant to the threads on the plug. Then, place the C-seal retainer onto the plug and tighten the retainer using an appropriate tool such as a strap wrench.
5. Using an appropriate tool such as a center punch, stake the threads on top of the plug in one place (figure 14) to secure the C-seal retainer.
6. Install the new plug/retainer assembly with C-seal plug seal on the new stem following the appropriate instructions in the Trim Replacement section in this manual.
7. Install piston rings by following instructions in the Trim Replacement section in this manual.
8. Remove the existing valve actuator and bonnet following the appropriate instructions in the Replacing Packing section in this manual.

CAUTION

Do not remove the existing valve stem from the valve plug unless you are planning to replace the valve stem.

Never reuse an old valve stem with a new plug or reinstall a valve stem after it has been removed. Replacing a valve stem requires drilling a new pin hole in the stem. This drilling weakens the stem and may cause failure in service. However, a used valve plug may be reused with a new valve stem.

9. Remove the existing valve stem and plug, cage, and seat ring from the valve body following the appropriate instructions in the Trim Removal section in this manual.
10. Replace all gaskets according to appropriate instructions in the Trim Replacement section in this manual.
11. Install the new seat ring, cage, valve plug/retainer assembly, and stem into the valve body and completely reassemble the valve package following the appropriate instructions in the Trim Replacement section in this manual.

Figure 13. Installing the C-seal Plug Seal Using the Installation Tool

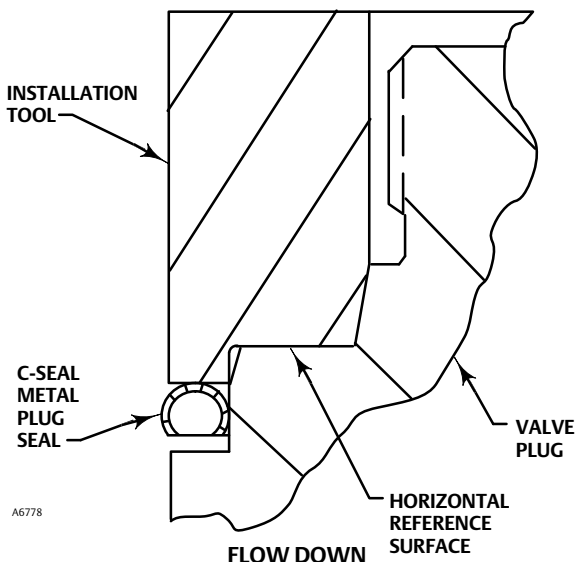

NOTE: PRESS THE INSTALLATION TOOL OVER THE VALVE PLUG UNTIL THE TOOL CONTACTS THE HORIZONTAL REFERENCE SURFACE OF THE VALVE PLUG.

Figure 14. Stake the Threads of the C-seal Retainer

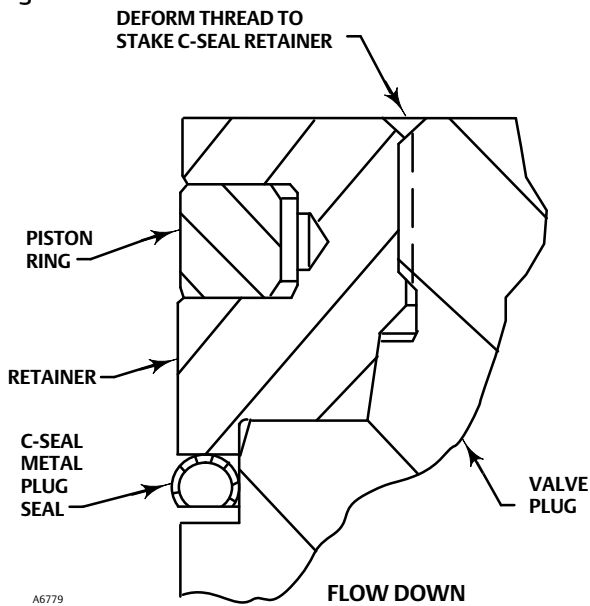

CAUTION

To avoid excessive leakage and seat erosion, the valve plug must be initially seated with sufficient force to overcome the resistance of the C-seal plug seal and contact the seat ring. You can correctly seat the valve plug by using the same force calculated for full load when sizing your actuator. With no pressure drop through the valve, this force will adequately drive the valve plug to the seat ring, thus giving the C-seal plug seal a predetermined permanent set. Once this is done, the plug/retainer assembly, the cage, and the seat ring become a matched set.

With full actuator force applied and the valve plug fully seated, align the actuator travel indicator scale with the lower end of valve travel. Refer to the appropriate actuator instruction manual for information on this procedure.

Replacement of Installed C-seal Trim

Trim Removal (C-seal Constructions)

1. Remove the valve actuator and bonnet following the appropriate instructions in the Replacing Packing section in this manual.

CAUTION

To avoid leakage when the valve is returned to service, use appropriate methods and materials to protect all sealing surfaces of the trim parts during maintenance.

Use caution when removing piston ring(s) and C-seal plug seal to avoid scratching any sealing surface.

CAUTION

Do not remove the valve stem from the plug/retainer assembly unless you are planning to replace the valve stem.

Never reuse an old valve stem with a new plug or reinstall a valve stem after it has been removed. Replacing a valve stem requires drilling a new pin hole in the stem. This drilling weakens the stem and may cause failure in service. However, a used valve plug may be reused with a new valve stem.

2. Remove the plug/retainer assembly (with C-seal plug seal), cage, and seat ring from the valve body following the appropriate instructions in the Trim Removal section in this manual.
3. Locate the staked thread on top of the valve plug (figure 14). The staked thread secures the retainer. Use a drill with a 1/8 inch bit to drill out the staked area of the thread. Drill approximately 1/8-inch into the metal to remove the staking.
4. Locate the break between sections of the piston ring(s). Using an appropriate tool such as a flat-blade screwdriver, carefully pry out the piston ring(s) from the groove(s) in the C-seal retainer.
5. After removing the piston ring(s), locate the 1/4-inch diameter hole in the groove. In a retainer with two piston ring grooves, the hole will be found in the upper groove.
6. Select an appropriate tool such as a punch and place the tip of the tool into the hole with the body of the tool held tangent to the outside diameter of the retainer. Strike the tool with a hammer to rotate the retainer and free it from the valve plug. Remove the retainer from the plug.
7. Use an appropriate tool such as a flat-blade screwdriver to pry the C-seal plug seal off the plug. Use caution to avoid scratches or other damage to the sealing surfaces where the C-seal plug seal makes contact with the valve plug (figure 15).
8. Inspect the lower seating surface where the valve plug contacts the seat ring for wear or damage which would prevent proper operation of the valve. Also, inspect the upper seating surface inside the cage where the C-seal plug seal contacts the cage, and inspect the sealing surface where the C-seal plug seal makes contact with the plug (figure 15).
9. Replace or repair trim parts according to the following procedure for Lapping Metal Seats, Remachining Metal Seats, or other valve plug maintenance procedures as appropriate.

Lapping Metal Seats (C-seal Constructions)

Before installing a new C-seal plug seal, lap the lower seating surface (valve plug to seat ring, figure 15) following appropriate procedures in the Lapping Seats section in this manual.

Remachining Metal Seats (C-seal Constructions)

See figure 16. A valve plug with a C-seal metal plug seal features two seating surfaces. One seating surface is found where the valve plug contacts the seat ring. The second seating surface is found where the C-seal plug seal contacts the upper seating surface in the cage. If you machine the seats on the seat ring and/or plug, you must machine an equal dimension from the seating area in the cage.

CAUTION

If metal is removed from the seat ring and plug and a corresponding amount is not removed from the cage seating area, the C-seal plug seal will be crushed as the valve closes and the C-seal retainer will strike the seating area of the cage, preventing the valve from closing.

Figure 15. Lower (Valve Plug to Seat Ring) and Upper (C-seal Plug Seal to Cage) Seating Surfaces

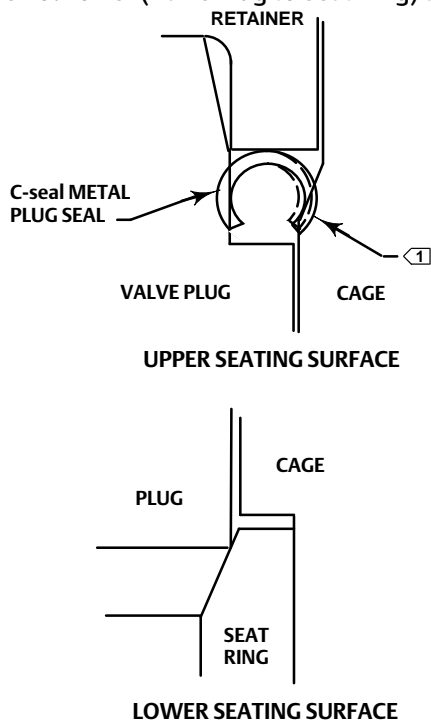

NOTE:

1 UPPER SEATING SURFACE IS THE AREA OF CONTACT BETWEEN THE C-seal METAL PLUG SEAL AND THE CAGE.

A6780

Trim Replacement (C-seal Constructions)

1. Apply a suitable high-temperature lubricant to the inside diameter of the C-seal plug seal. Also, lubricate the outside diameter of the valve plug where the C-seal plug seal must be pressed into the proper sealing position (figure 11).
2. Orient the C-seal plug seal for correct sealing action based on the process fluid flow direction through the valve.
 - The open interior of the C-seal plug seal must face up in a valve with flow-up construction (figure 11).
 - The open interior of the C-seal plug seal must face down in a valve with flow-down construction (figure 11).

Note

An installation tool must be used to properly position the C-seal plug seal on the valve plug. A tool is available as a Fisher spare part or a tool could be manufactured following the dimensions given in figure 12.

3. Place the C-seal plug seal over the top of the valve plug and press it onto the plug using the installation tool. Carefully press the C-seal plug seal onto the plug until the installation tool contacts the horizontal reference surface of the valve plug (figure 13).
4. Apply a suitable high-temperature lubricant to the threads on the plug. Then, place the C-seal retainer onto the plug and tighten the retainer using an appropriate tool such as a strap wrench.

Figure 16. Example of Machining the Lower (Valve Plug to Seat Ring) and Upper (C-seal Plug Seal to Cage) Seating Surfaces

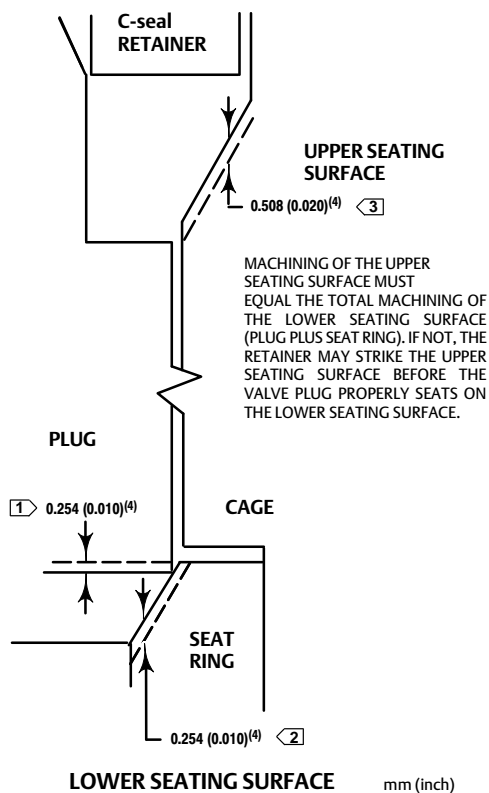

MACHINING OF THE UPPER SEATING SURFACE MUST EQUAL THE TOTAL MACHINING OF THE LOWER SEATING SURFACE (PLUG PLUS SEAT RING). IF NOT, THE RETAINER MAY STRIKE THE UPPER SEATING SURFACE BEFORE THE VALVE PLUG PROPERLY SEATS ON THE LOWER SEATING SURFACE.

- NOTE:
- REMOVAL OF 0.010 INCH FROM THE SEAT RING
 - $\langle 1 \rangle$ REMOVAL OF 0.254 mm (0.010 inch) FROM THE VALVE PLUG
 - $\langle 2 \rangle$ REMOVAL OF 0.254 mm (0.010 inch) FROM THE SEAT RING
 - $\langle 3 \rangle$ REMOVAL OF 0.508 mm (0.020 inch) FROM THE UPPER SEATING SURFACE IN THE CAGE
 - 4. THESE VALUES ARE FOR EXAMPLE ONLY. REMOVE ONLY THE MINIMUM AMOUNT OF MATERIAL REQUIRED TO REFURBISH THE SEATS.

A6781 /IL

5. Using an appropriate tool such as a center punch, stake the threads on top of the plug in one place (figure 14) to secure the C-seal retainer.
6. Replace the piston rings following instructions in the Trim Replacement section in this manual.
7. Return the seat ring, cage, plug/retainer assembly, and stem to the valve body and completely reassemble the valve package following the appropriate instructions in the Trim Replacement section in this manual.

CAUTION

To avoid excessive leakage and seat erosion, the valve plug must be initially seated with sufficient force to overcome the resistance of the C-seal plug seal and contact the seat ring. You can correctly seat the valve plug by using the same force calculated for full load when sizing your actuator. With no pressure drop through the valve, this force will adequately drive the valve plug to the seat ring, thus giving the C-seal plug seal a predetermined permanent set. Once this is done, the plug/retainer assembly, the cage, and the seat ring become a matched set.

With full actuator force applied and the valve plug fully seated, align the actuator travel indicator scale with the lower end of valve travel. Refer to the appropriate actuator instruction manual for information on this procedure.

Parts Ordering

Each body-bonnet assembly is assigned a serial number, which can be found on the valve body. This same number also appears on the actuator nameplate when the valve body is shipped from the factory as part of a control valve assembly. Refer to the number when contacting your [Emerson sales office](#) or Local Business Partner for technical assistance or when ordering replacement parts.

⚠ WARNING

Use only genuine Fisher replacement parts. Components that are not supplied by Emerson Automation Solutions should not, under any circumstances, be used in any Fisher valve, because they may void your warranty, might adversely affect the performance of the valve, and could cause personal injury and property damage.

Parts Kits

Standard Packing Kits (Non Live-Loaded)

Stem Diameter, mm (Inches) Yoke Boss Diameter, mm (Inches)	12.7 (1/2) 71 (2-13/16)	19.1 (3/4) 90 (3-9/16)	25.4 (1) 127 (5)	31.8 (1-1/4) 127 (5, 5H)
PTFE (Contains keys 22, 24, 25, 26, 27)	RPACKX00022	RPACKX00032	RPACKX00342	RPACKX00352
Double PTFE (Contains keys 22, 24, 26, 27)	RPACKX00052	RPACKX00062	RPACKX00362	RPACKX00372
Single Graphite Ribbon/Filament (Contains keys 23 [ribbon ring], 23 [filament ring], 24, and 26)	RPACKX00112	RPACKX00122	---	---
Single Graphite Ribbon/Filament (Contains keys 23 [ribbon ring], 23 [filament ring], and 26)	---	---	RPACKX00532	RPACKX00542
Single Graphite Ribbon/Filament (Contains keys 23 [ribbon ring], 23 [filament ring])	RPACKX00142	RPACKX00152	---	---

Repair Kits (ENVIRO-SEAL)

Stem Diameter, mm (Inches) Yoke Boss Diameter, mm (Inches)	12.7 (1/2) 71 (2-13/16)	19.1 (3/4) 90 (3-9/16)	25.4 (1) 127 (5)	31.8 (1-1/4) 127 (5, 5H)
Double PTFE (Contains keys 214, 215, 218)	RPACKX00202	RPACKX00212	RPACKX00222	RPACKX00232
Graphite ULF (Contains keys 207, 208, 209, 210, 214)	RPACKX00602	RPACKX00612	RPACKX00622	RPACKX00632
Duplex (Contains keys 207, 209, 214, 215)	RPACKX00302	RPACKX00312	RPACKX00322	RPACKX00332

Retrofit Kits (ENVIRO-SEAL)

Stem Diameter, mm (Inches) Yoke Boss Diameter, mm (Inches)	12.7 (1/2) 71 (2-13/16)	19.1 (3/4) 90 (3-9/16)	25.4 (1) 127 (5)	31.8 (1-1/4) 127 (5, 5H)
Double PTFE (Contains keys 200, 201, 211, 212, 214, 215, 216, 217, 218, tag, cable tie)	RPACKXRT022	RPACKXRT032	RPACKXRT042	RPACKXRT052
Graphite ULF (Contains keys 200, 201, 207, 208, 209, 210, 211, 212, 214, 217, tag, cable tie)	RPACKXRT272	RPACKXRT282	RPACKXRT292	RPACKXRT302
Duplex (Contains keys 200, 201, 207, 209, 211, 212, 214, 215, 216, 217, tag, cable tie)	RPACKXRT222	RPACKXRT232	RPACKXRT242	RPACKXRT252

Gasket Set* (Includes Key 11 Bonnet Gasket and Key 12 Seat Ring Gasket)⁽¹⁾

VALVE RATING	VALVE STYLE AND SIZE, NPS		MATERIAL	
	HP Globe	HPA Angle	N06600/Graphite	N07750/Graphite
CL1500 Globe and Angle Valves	1 (std)	1 (std)	12B7100X012	12B7100X022
	2 (std)	2 (std) and 3 (std)	12B7100X032	12B7100X042
	2 (Cavitrol III, 2-Stage)	2 (Cavitrol III, 2-Stage)	12B7100X072	---
	3 (std)	4 (std)	12B7100X052	12B7100X062
	4 (std)	6 (std)	12B7100X082	---
	6 (std)	8 (std)	12B7100X112	---
CL2500 Globe and Angle Valves	1 (std)	1 (std)	12B7100X152	12B7100X122
	2 (std)	2 (std)	12B7100X162	12B7100X132
	2 (Cavitrol III, 2-Stage)	2 (Cavitrol III, 2-Stage)	12B7100X172	12B7100X142

1. Gaskets should always be replaced as sets, not separately.

Figure 17. NPS 1 HPS Valve

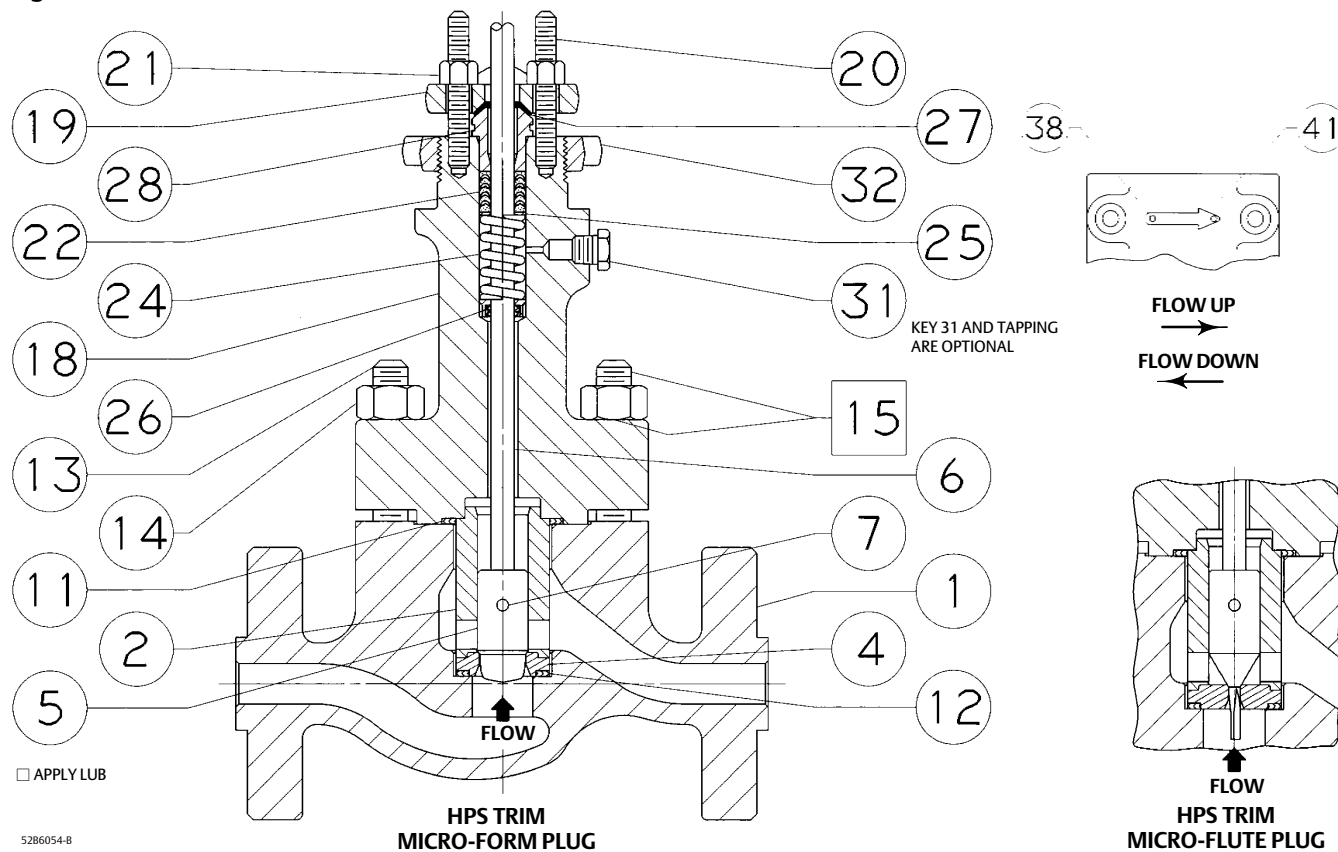

Figure 18. NPS 2 HPAD Valve

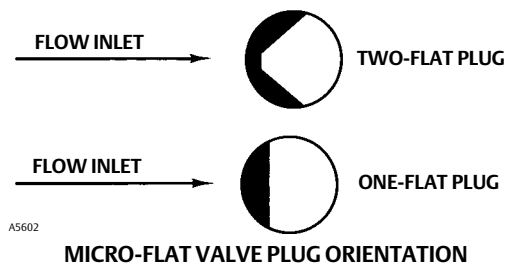
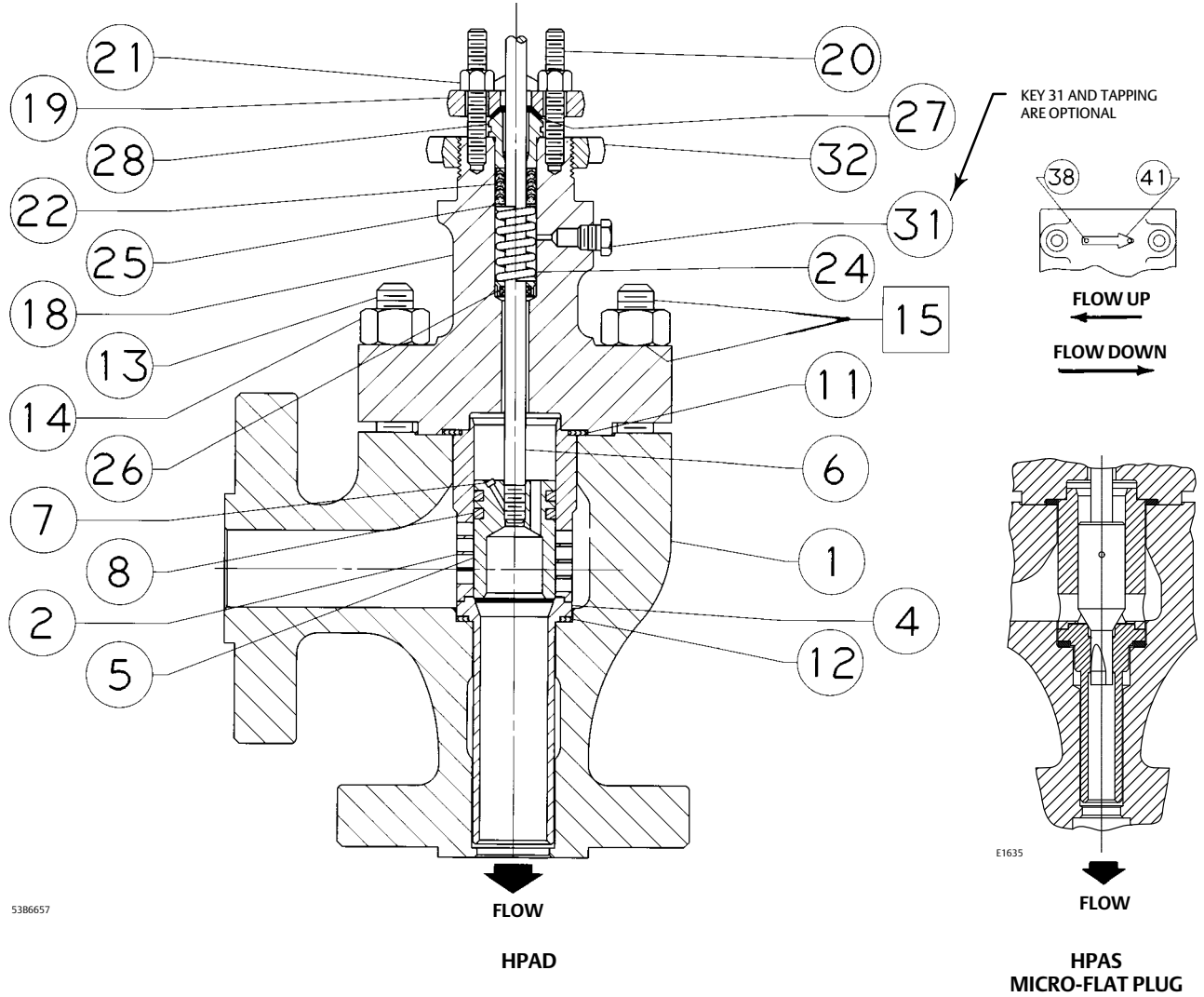

Figure 19. NPS 2-6 HPD Valve

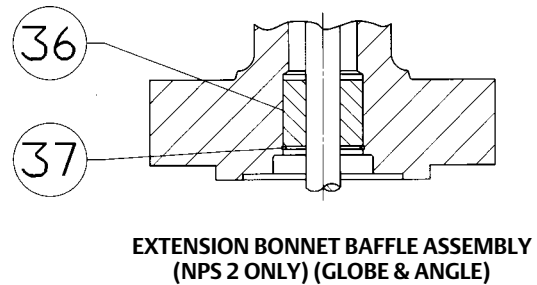
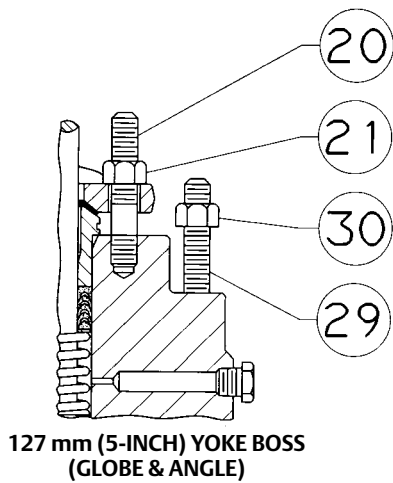
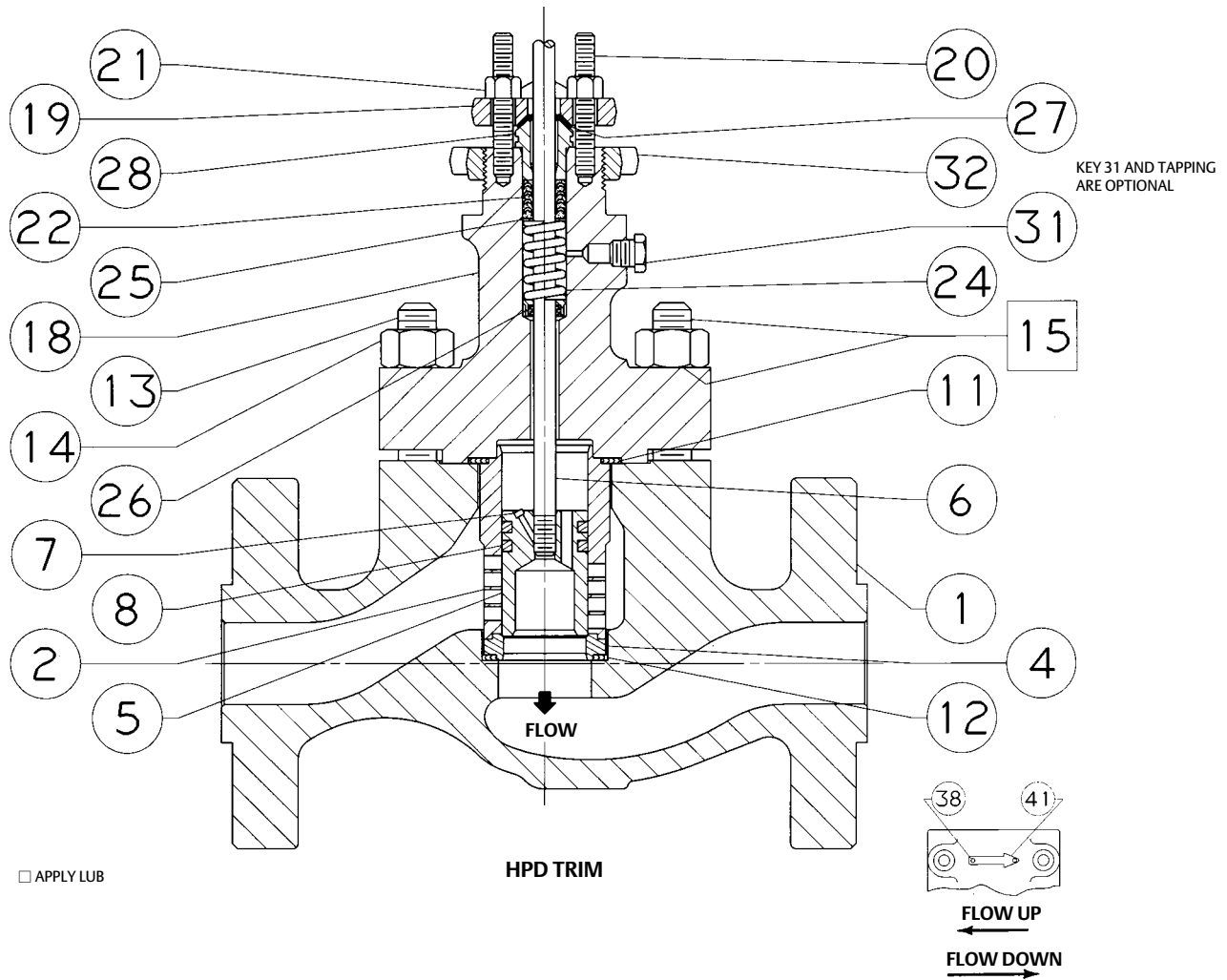
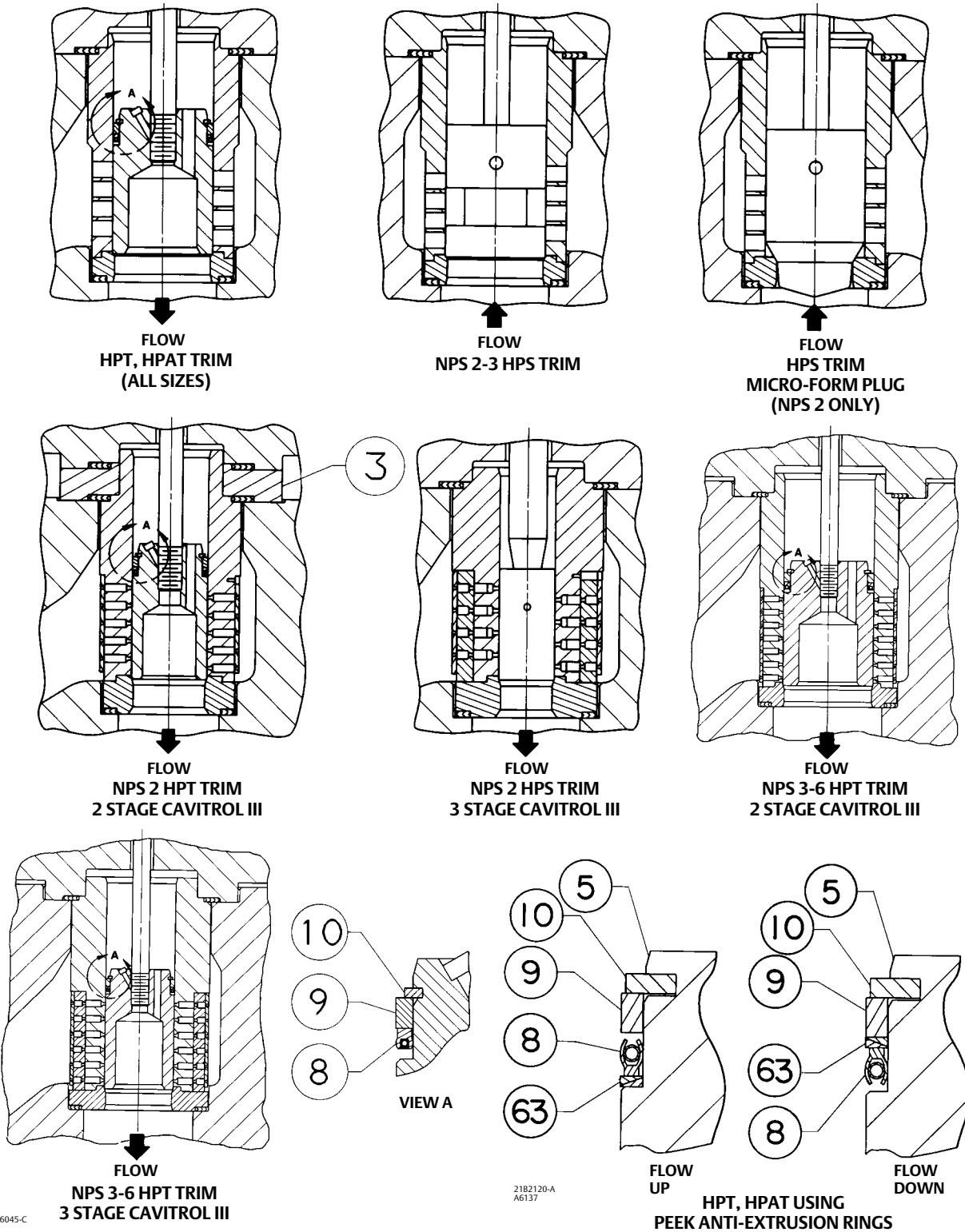
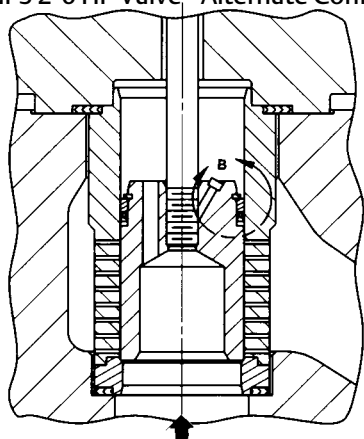

Figure 20. NPS 2-6 HP Valve - Alternate Configurations



5286045-C

Figure 20. NPS 2-6 HP Valve - Alternate Configurations (Continued)



FLOW
HPT, HPAT TRIM WHISPER III,
AVAILABLE IN HPD, HPAD, HPS,
AND HPAS (NPS 2)

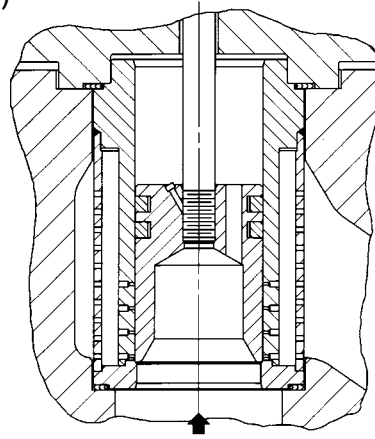

FLOW
NPS 4 HPD TRIM
WHISPER III
LEVEL D

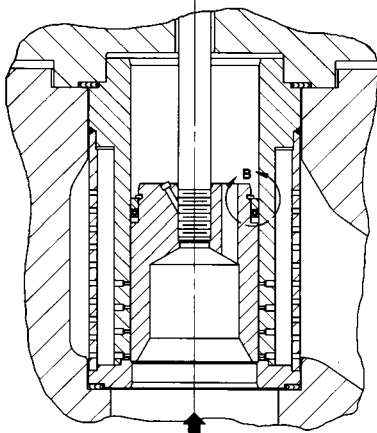

FLOW
NPS 4 HPT TRIM WHISPER III LEVEL D

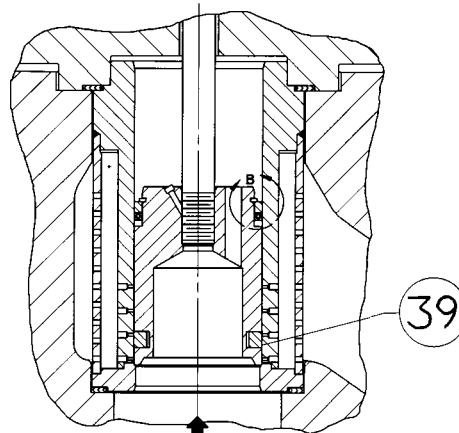

FLOW
NPS 6 HPT TRIM WHISPER III LEVEL D

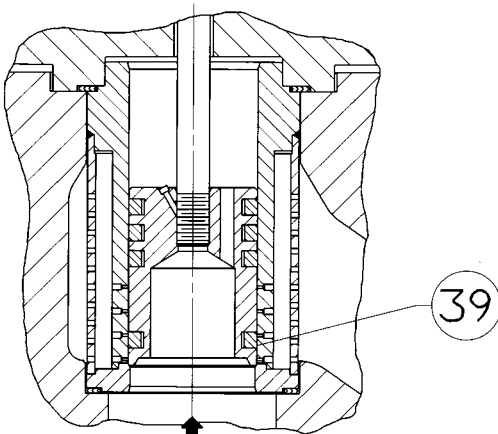

FLOW
NPS 6 HPD TRIM WHISPER III LEVEL D

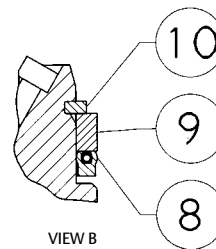

VIEW B

5286045-C

Parts List

Numerous available combinations of valve parts make selection of some parts difficult; when ordering valve parts, provide the valve serial number with the order, permitting proper selection of replacement parts to be made at the factory.

Note

Contact your [Emerson sales office](#) or Local Business Partner for Part Ordering information.

Key	Description
1	Valve Body If you need a valve body as a replacement part, order by valve size, serial number, and desired material.
2*	Cage/Baffle Assy
3	Bonnet Spacer
4*	Seat Ring
5*	Valve Plug
6*	Valve Stem
7*	Pin
8*	Seal Ring/Piston Ring
9*	Back Up Ring
10*	Retaining Ring (for HPT/HPAT only)
11*	Bonnet Gasket
12*	Seat Ring Gasket
13	Stud, Cont Thd
14	Hex Nut
15	Anti-Seize Lubricant (8 lb [3.6 Kg] can)
16	Nameplate
17	Wire
18	Bonnet If you need a bonnet as a replacement part, order by valve size and stem diameter, serial number, and desired material.
19	Packing Flange

Key	Description
20	Stud Bolt
21	Hex Nut
22*	Packing Set
23*	Packing Ring
24	Spring or Lantern Ring
25	Washer, Special
26*	Packing Box Ring
27*	Upper Wiper
28	Follower
29	Stud Bolt
30	Hex Nut
31	Pipe Plug (optional)
31	Lubricator (optional)
31	Lubricator/Isolating Valve (optional)
32	Yoke Locknut (optional)
36	Baffle
37	Retaining Ring
38	Drive Screw
39*	Piston Ring
40	Washer
41	Flow Arrow
63*	Anti-Extrusion Ring

C-seal Trim (figure 11)

2*	Cage
4*	Seat Ring
5*	Valve Plug/Retainer
6*	Valve Plug Stem, S20910
8*	Piston Ring, graphite (2 req'd)
64*	C-seal, N07718

TSO Trim (figures 7, 8, and 9)

2*	Cage
4*	Seat Ring
5*	Plug/Stem Assembly
8*	Seal Ring
63*	Anti-Extrusion Ring
9*	Back Up Ring
10*	Retaining Ring

*Recommended spare parts

Neither Emerson, Emerson Automation Solutions, nor any of their affiliated entities assumes responsibility for the selection, use or maintenance of any product. Responsibility for proper selection, use, and maintenance of any product remains solely with the purchaser and end user.

Fisher, Cavitol, ENVIRO-SEAL, FIELDVUE, Whisper Trim, and WhisperFlo are marks owned by one of the companies in the Emerson Automation Solutions business unit of Emerson Electric Co. Emerson Automation Solutions, Emerson, and the Emerson logo are trademarks and service marks of Emerson Electric Co. All other marks are the property of their respective owners.

The contents of this publication are presented for informational purposes only, and while every effort has been made to ensure their accuracy, they are not to be construed as warranties or guarantees, express or implied, regarding the products or services described herein or their use or applicability. All sales are governed by our terms and conditions, which are available upon request. We reserve the right to modify or improve the designs or specifications of such products at any time without notice.

Emerson Automation Solutions
 Marshalltown, Iowa 50158 USA
 Sorocaba, 18087 Brazil
 Cernay, 68700 France
 Dubai, United Arab Emirates
 Singapore 128461 Singapore

www.Fisher.com

