

 **Dings** magnetic group
CO.

ELECTRO OVERHEAD MAGNETS



Self-Cleaning



Stationary



Severe Duty

RECYCLING | COAL/POWER PLANTS | QUARRY/AGGREGATE | LUMBER/WOOD/BIO MASS
AUTOMOTIVE & WHITE GOODS | FOUNDRY | STEEL/SLAG PROCESSING | MINING/MINERALS

Overhead separators suspend above belt or vibratory conveyors, magnetically lifting ferrous metals out of bulk material. They are used for steel recovery, separating ferrous metals from nonmagnetic material. Overhead magnets also protect processing equipment, removing damaging tramp metal that can cause costly repairs and downtime.

10-YEAR WARRANTY
Against Coil Burnout

Self-Cleaning

A belt travels continuously around the body of the magnet to discharge ferrous metals. Recovered metal objects are removed automatically from the magnetic zone.

These powerful separators come equipped with a heavy duty rubber belt with 1" vulcanized cleats to continuously remove metal from the product stream (3" cleats available for material recycling facilities).



Features

- 10-Year warranty against coil burnout
- No need for external expansion tank - oil expansion takes place internally
- Coil exceeds Class "H" insulation rating
- Sizes to fit any belt width
- Heavy duty belt is standard
- AGMA Class II direct drive motor
- Additional wear plate provides extra protection for the magnet impact area

Options

- Choice of electric or hydraulic motor
- Dust covers, belt & pulley guards
- High temperature belt, MRF cleats
- Hazardous location models available
- Special voltages
- Crossbelt deflector
- Zero speed switch
- CSA approved models available
- Suspension systems -
-Turnbuckles, trolleys, wire rope
- Solid Waste Magnetic Systems

Severe Duty

This rugged version of the overhead magnet is designed for severe-duty applications such as concrete recycling and construction and demolition debris. The armor-clad Durabelt prolongs belt life in applications with sharp-edged steel or with frequent impact from large quantities of ferrous. Full-width metal cladding is available as an option for crossbelt applications.



Severe Duty Additional Features

- Armor-clad Durabelt
- Heavy duty drive package
- Lagging on the drive pulley
- Individual plates or cleats can be easily replaced in the field, saving on belt replacement costs and reducing downtime

Stationary

If tramp metal is an occasional problem, then a stationary magnet is the right choice. Just suspend it over the conveyor or over the head pulley. When the magnet surface starts to fill up, swing the magnet away from the conveyor and cut the power to release the attracted metal. Then swing the magnet back over the conveyor or head pulley.

Each Dings stationary overhead magnet is constructed with continuously welded stainless steel bottom plate, steel side plates and backplate. With no moving parts, there is nothing to lubricate, tighten or replace. You'll also find it easy to install your Dings magnet. It comes complete with a convenient 3 point suspension system consisting of two cables and one turnbuckle connected to a common bull ring.

To change the suspension angle, simply adjust the turnbuckle. There's no measuring, shortening, lengthening or cutting of cable.



Features

- 10-Year warranty against coil burnout
- No need for external expansion tank - oil expansion takes place internally
- Coil exceeds Class "H" insulation rating
- Stainless steel bottom plate, steel side plates and backplate
- Easy installation
- Additional wear plate provides extra protection for the magnet impact area

Options

- Hazardous location models available
- CSA approved models available
- Suspension systems -
- turnbuckles, trolleys, wire rope

Overhead Magnet Specifications

Balanced magnetic circuit

Coils are wound with anodized aluminum strap exceeding class H insulation

Non-deteriorating glastic coil spacers and core insulation

Solid steel center core

Full stainless steel bottom plate

3/16" thick stainless steel replaceable wear plate on center impact area of magnet

Thick steel side plates in magnet case

NEMA 4 weather tight construction magnet box and terminal

Magnet case filled with high dielectric strength transformer oil for effective cooling

Features

INDUSTRY'S BEST! 10-YEAR WARRANTY
Exclusive Coil Design Protects Against Magnet Burn-out

Dings electromagnets are wound with anodized aluminum strap, an exclusive design that lasts longer and generates more magnetism than any other on the market.

- Coils don't require additional insulation
- Extra turns fit into same area- generating more magnetism and power
- Every turn exposed to oil cooling - cooler coils perform better
- Eliminates the need for external oil expansion tank



Other features:

- Easy access to oil level, drain, and fill plugs
- Common size pulleys and pillow block bearings
- Four lifting lugs
- One way pressure relief valve keeps moisture out
- NEMA 4 weather-tight magnet box and terminal connection box
- Full 7-gauge stainless steel bottom plate with extra replaceable center wear plate at area of impact
- Stainless steel crossbelt deflector reduces wear, minimizes cleaning & extends belt life; Interchangeable side to side

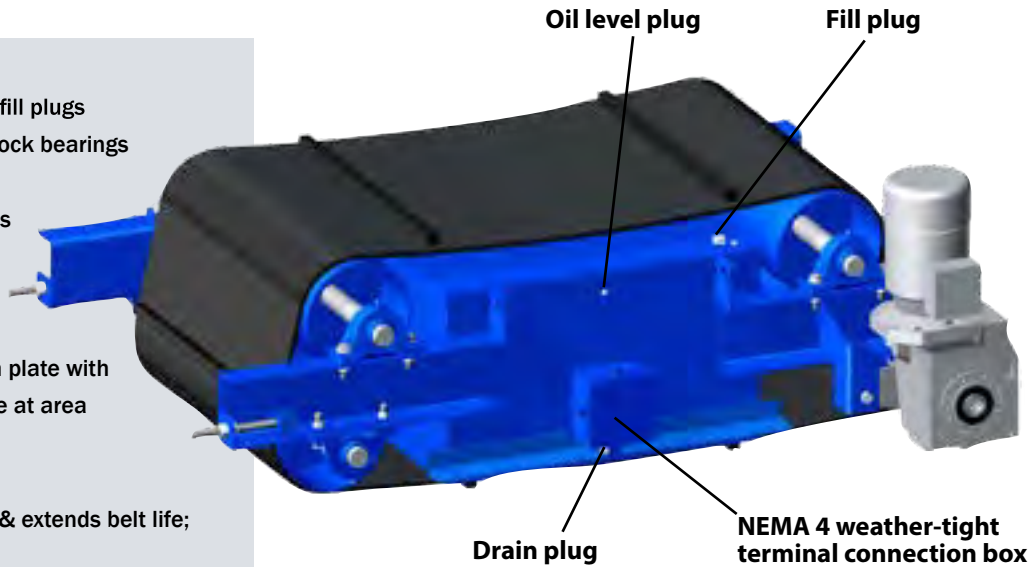

IP56 AGMA class II direct gear motor
 Operation in temperature -25° C to 60° C
 Option of electric or hydraulic motor

Heavy duty belt with 1" cleats standard
 MRF belt, severe duty belts available

End crown curved pulley for belt tracking

Breather valve

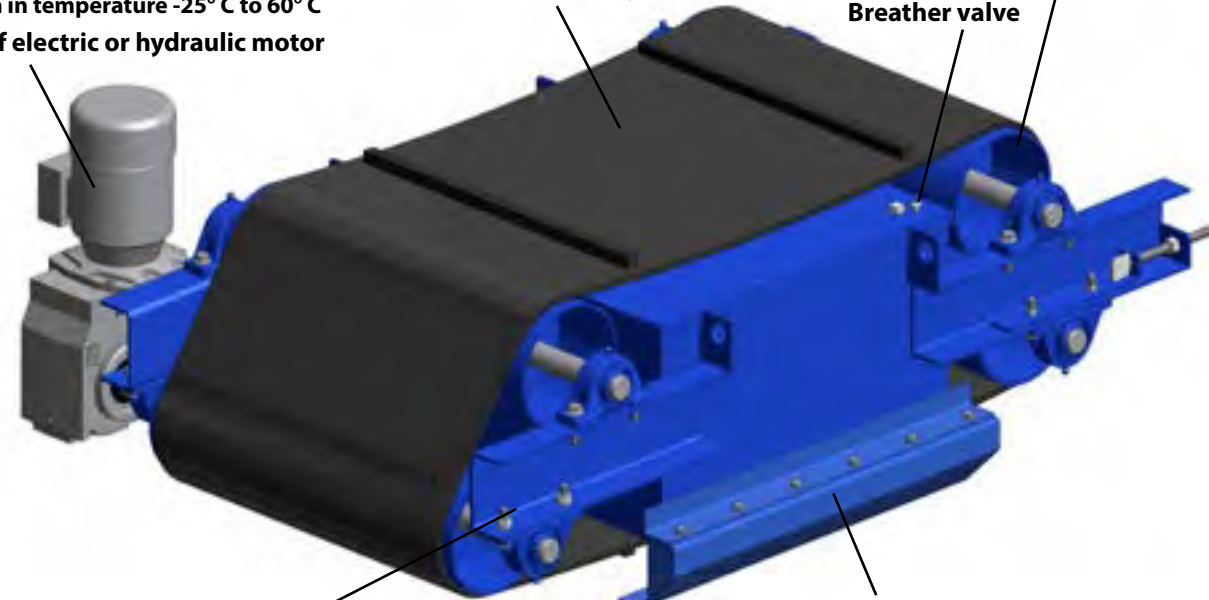

Heavy Duty frame construction

Stainless steel crossbelt deflector

Sizes

Self-Cleaning Models

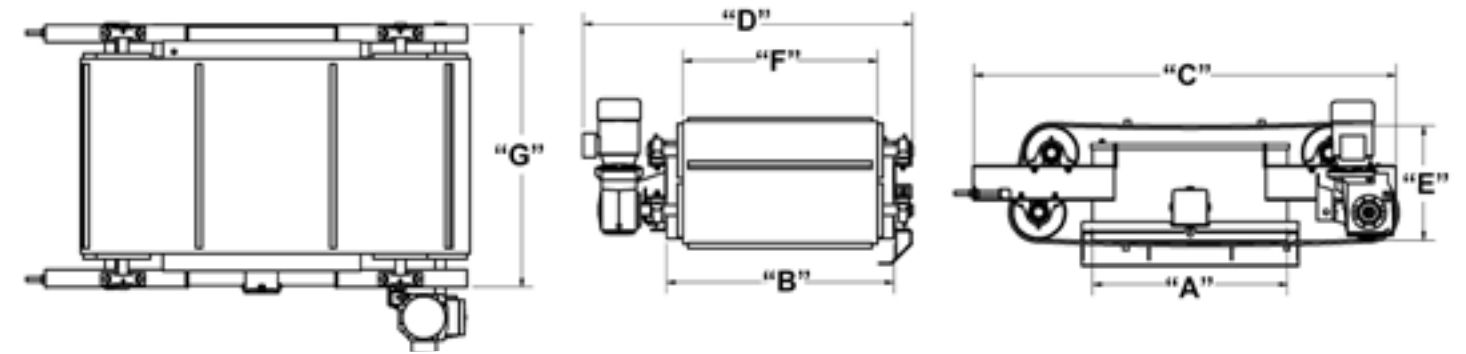

Magnet Model	Weight (lbs.)	Power (watts)	Drive Motor (h.p.)	A Length		B Width		C Overall		D Overall		E Height	F Belt		G Frame	
				Inline	Crossbelt	Inline	Crossbelt	Inline	Crossbelt	Inline	Crossbelt		Inline	Crossbelt	Inline	Crossbelt
22	2,600	3,000	5	36"	30"	30"	36"	78"	72"	49"	55"	18"	24"	30"	37"	43"
22T				30"	36"	36"	30"	72"	78"	55"	49"	18"	30"	24"	43"	37"
33	3,450	4,500	5	42"	36"	36"	42"	84"	78"	55"	61"	18"	30"	36"	43"	49"
33T				36"	42"	42"	36"	78"	84"	61"	55"	18"	36"	30"	49"	43"
44	4,700	6,500	5	48"	42"	42"	48"	90"	84"	61"	67"	19"	36"	42"	49"	55"
44T				42"	48"	48"	42"	84"	90"	67"	61"	19"	42"	36"	55"	49"
55	6,400	8,000	5	54"	48"	48"	54"	96"	90"	67"	73"	22"	42"	50"	55"	61"
55T				48"	54"	54"	48"	90"	96"	73"	67"	22"	50"	42"	61"	55"
66	9,000	10,000	5	60"	54"	54"	60"	113"	107"	73"	79"	23"	48"	54"	61"	67"
66T				54"	60"	60"	54"	107"	113"	79"	73"	23"	54"	48"	67"	61"
77	12,500	12,500	5	66"	60"	60"	66"	119"	113"	79"	85"	28"	54"	60"	67"	73"
77T				60"	66"	66"	60"	113"	119"	85"	79"	28"	60"	54"	73"	67"
88	15,650	14,000	7.5	72"	66"	66"	72"	128"	122"	89"	95"	28"	60"	66"	75"	81"
88T				66"	72"	72"	66"	122"	128"	95"	89"	28"	66"	60"	81"	75"
99	18,400	15,000	7.5	78"	72"	72"	78"	134"	128"	95"	101"	29"	66"	72"	81"	87"
99T				72"	78"	78"	72"	128"	134"	101"	95"	29"	72"	66"	87"	81"

Stationary Models

Magnet Model	Weight (lbs.)	Power (watts)	A Length	B Width	C Suspension Distance	D Box Height
22	1,700	3,000	36"	30"	46"	18"
22T			30"	36"	46"	18"
33	2,450	4,500	42"	36"	48"	18"
33T			36"	42"	48"	18"
44	3,600	6,500	48"	42"	57"	19"
44T			42"	48"	57"	19"
55	5,200	8,000	54"	48"	64"	22"
55T			48"	54"	64"	22"
66	7,100	10,000	60"	54"	68"	23"
66T			54"	60"	68"	23"
77	9,950	12,500	66"	60"	90"	27"
77T			60"	66"	90"	27"
88	10,750	14,000	72"	66"	91"	28"
88T			66"	72"	91"	28"
99	16,200	15,000	78"	72"	90"	29"
99T			72"	78"	90"	29"

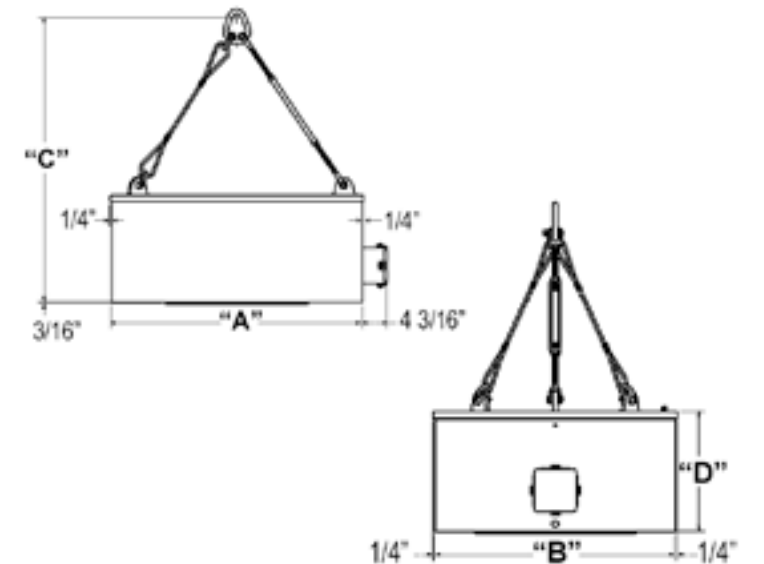

Installation

A Self-Cleaning electro overhead magnet is available in two suspension types: Inline and Crossbelt.

An Inline magnet is installed over a conveyor head pulley so that the cleaning belt runs parallel to the travel direction of material falling off the conveyor. The head pulley must be made from non-magnetic material. A Crossbelt magnet is installed over a conveyor so that the cleaning belt runs at a right angle to the travel direction of the material on the conveyor.

Magnetic performance may be affected by magnetic material in the field. This includes such items as I-beams, metal supports, hoppers, or splitters. These and other ferrous objects need to be kept out of the magnetic zone.

Magnetic performance may be affected by magnetic material in the field: see "Non-magnetic area" on the next page.

Suspension height is critical to the performance of the magnet. This distance is measured from the bottom of the magnet face to the surface of the material handling belt. Elevate the magnet to the suspension height that is appropriate for the application. An appropriate height is 2" - 3" above the top of the conveyed material or the height specified at the time of purchase. If a height is specified, measure it at the middle of the conveyor belt, on its surface, up to the magnet face - the bottom surface of the magnet.

If the magnet is too high above the burden, sufficient magnetism may not reach into the burden and cause a loss in separation efficiency. For best results, crossbelt separators should be centered over the belt and parallel to the slope of the belt conveyor.

IMPORTANT:

IN-LINE installation is preferred because separation efficiency is better when the magnet is located over where the conveyed material opens up during its path through the air.

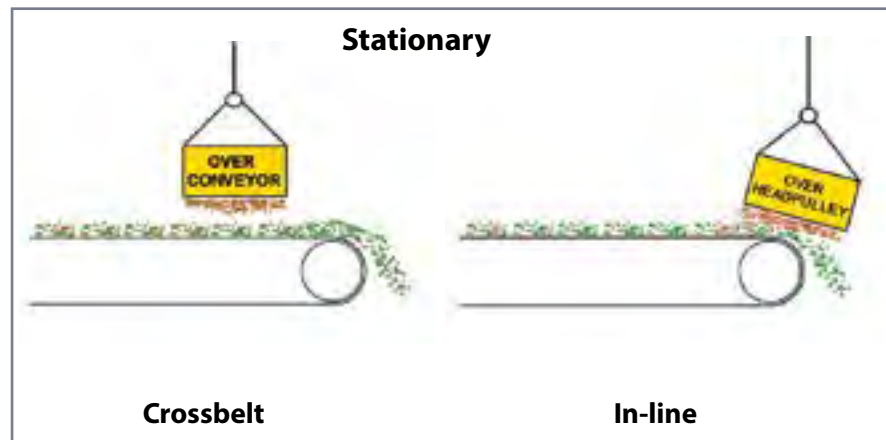
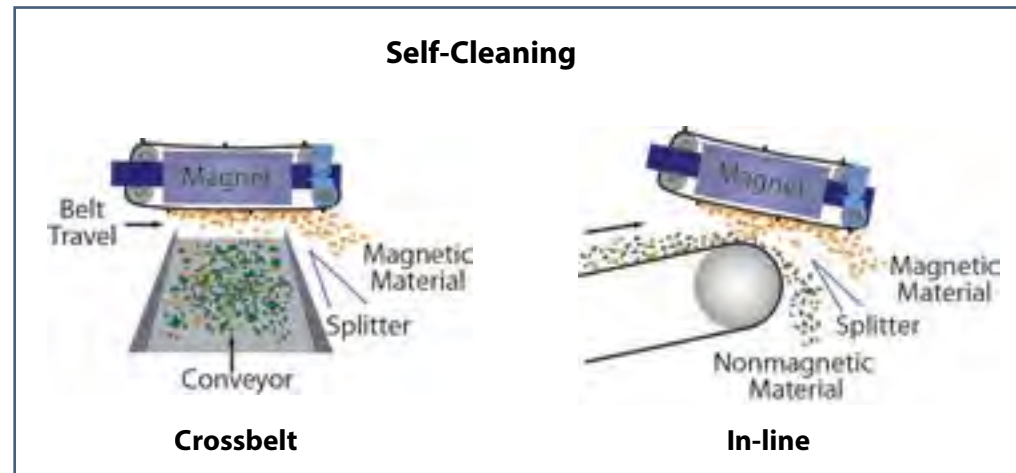

Non-magnetic area

Magnetic performance is affected by magnetic material in the field; in the shaded area, no construction parts that can be magnetized are permitted. Pulleys, rollers, frames, supports, etc., must be made of material that cannot be magnetized. When installing the magnet in-line, the head pulley must be non-magnetic.

Model	Suspension Height	Width "A"	Length "B"
22	UP TO 10"	30"	36"
33	UP TO 13"	36"	42"
44	UP TO 15"	42"	48"
55	UP TO 17"	48"	54"
66	UP TO 19"	54"	60"
77	UP TO 21"	60"	66"
88	UP TO 24"	66"	72"
99	UP TO 27"	72"	78"

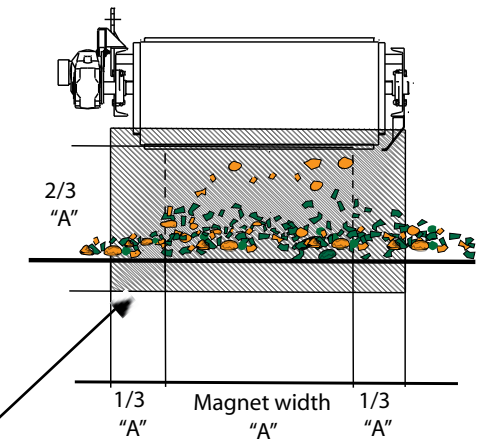

Non-magnetic area shown as shaded areas

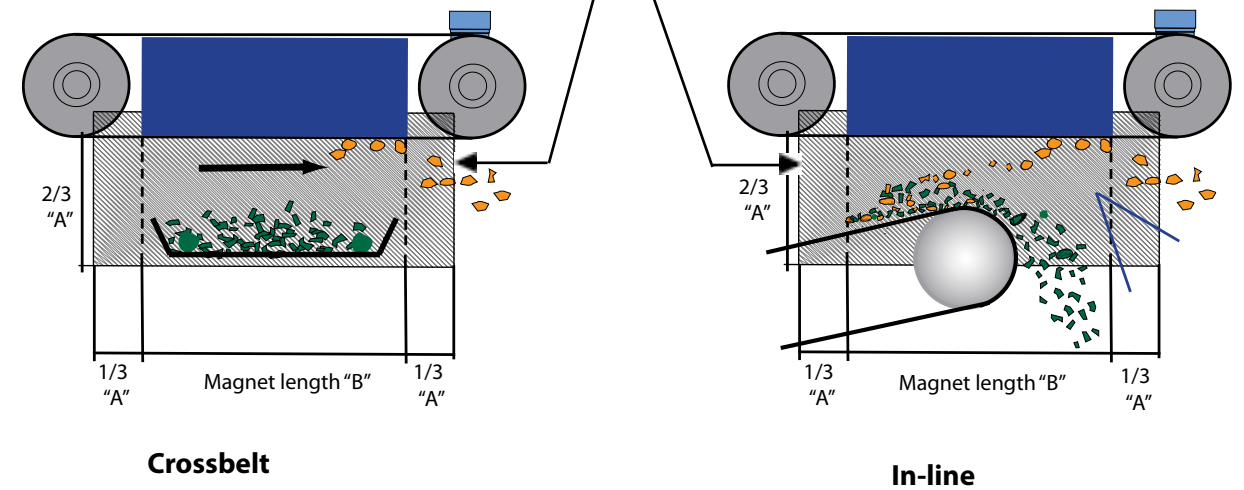

AC Rectifiers

All electromagnets require a steady DC current. Dings rectifiers are designed to transform the alternating current from your local power source to the necessary direct current.

FEATURES

- DC wattage up to 50Kw to match separator requirements
- No maintenance solid state silicon diode
- Voltage regulation within 3.5% from no load to full load
- Overload capacity for short infrequent periods
- Hinged door cabinet for easy access
- Available in NEMA 12, 4, 4XSS, or 9
- Delta-Wye construction





In-House Testing

Unsure which product is best for your application?

Just send us a sample of your product with a brief description of what you are trying to accomplish. We'll be happy to test it on actual equipment at our in-house testing laboratory at no charge. We will then give you a report and recommend the best equipment for your particular application.

Custom Design

Don't see exactly what you're looking for in our standard products? Our team of highly experienced sales engineers will work with you to design the perfect separator for your application. Using state of the art computer modeling and design, our engineers will provide you with certified prints prior to production to ensure that everything meets your requirements.

Rebuilds

If your magnet has been damaged and funds aren't available for replacement, consider having Dings rebuild it. In many cases, we can bring a magnet back to near-new condition at a cost substantially less than that of a new one.

Contact us to discuss your application

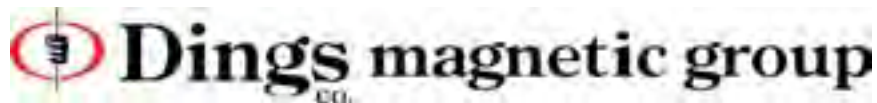

4740 W Electric Avenue, Milwaukee, WI 53219

Ph 414.672.7830 Fax 414.672.9421

www.dingsmagnets.com