Evaluating Accessibility for Transport Planning

Measuring People's Ability to Reach Desired Services and Activities

17 December 2021

Todd Litman
Victoria Transport Policy Institute



The Brooklyn Bridge provides mobility and access between Manhattan and Brooklyn.

Abstract

This paper discusses the concept of *accessibility* and how it can be incorporated in transport planning. Accessibility refers to people's ability to reach desired services and activities, which is the ultimate goal of most transport activity. Many factors affect accessibility, including mobility (physical movement), the quality and affordability of transport options, transport system connectivity, mobility substitutes, and land use patterns. Accessibility can be evaluated from various perspectives, including a particular group, mode, location or activity. Conventional planning tends to overlook and undervalue some of these factors and perspectives. More comprehensive analysis of accessibility in planning expands the scope of potential solutions to transport problems.

A shorter version of this paper was presented at the
87th Transportation Research Board Annual Meeting (www.trb.org), January 2008.

Todd Alexander Litman © 2007-2021

You are welcome and encouraged to copy, distribute, share and excerpt this document and its ideas, provided the author is given attribution. Please send your corrections, comments and suggestions for improvement.

Contents

Executive Summary	2
Introduction	4
Defining Accessibility	6
Factors That Affect Accessibility	8
Transportation Demand and Activity	8
Mobility	9
Transportation Options.....	10
User Information.....	11
Integration, Terminals and Parking	13
Affordability.....	14
Mobility Substitutes	15
Land Use Factors	16
Transportation Network Connectivity	20
Transportation System Management	22
Prioritization.....	23
The Value of Inaccessibility.....	26
Summary of Factors Affecting Accessibility	27
Perspectives	28
Individuals and Groups.....	28
Mode.....	29
Location	31
Activity	31
Summary	31
Evaluating Accessibility	32
Optimal Accessibility and Mobility	40
Evaluating Automobile Dependency.....	41
Strategies for Improving Accessibility	43
Examples	46
Best Practices	51
Conclusions.....	54
References and Resources for More Information	56
Acknowledgements.....	63

“An automobile is a machine for mobility. A city is a machine for accessibility.”

When people say, “location, location, location,” they really mean “accessibility, accessibility, accessibility.”

Executive Summary

Accessibility refers to people's overall ability to reach desired services and activities (together called *opportunities*), and therefore the time and money that people and businesses must devote to transportation. Accessibility is the ultimate goal of most transportation planning. Several factors can affect this accessibility:

- *Mobility*. The ease of physical movement, and therefore the quality (availability, frequency, speed, comfort, etc.) of travel modes (walking, bicycling, taxis, public transport, air travel, etc.).
- *Geographic proximity*. The distances between destinations, and therefore land use development factors such as development density and mix, which affect these distances.
- *Transport system connectivity*. This can include the density of sidewalk, road and public transit networks, and the quality of connections between modes, such as transit station bike parking, and transit connections to airports.
- *Affordability*. This refers to the financial costs of travel relative to users' income.
- *Convenience*. The ease of obtaining travel information, paying fares and carrying luggage.
- *Social acceptability*. The ability to use a mode sometimes depends on its social status.

Since accessibility is the ultimate goal of most transportation activity (excepting the small amount of travel that has no desired destination), transport planning should be based on accessibility. However, conventional planning tends to evaluate transport system performance based primarily on motor vehicle travel conditions using indicators such as roadway level-of-service, traffic speeds and vehicle operating costs; other accessibility factors are often overlooked or undervalued. This tends to favor mobility over accessibility and automobile transport over other modes.

Planning decisions often involve trade-offs between different forms of accessibility. For example, wider roads designed to maximize automobile traffic speeds tend to create barriers to walking and bicycling, reducing non-auto access. Similarly, denser development tends to reduce automobile travel speeds and parking supply, but improves walking, bicycling and public transit accessibility.

A new planning paradigm requires more comprehensive accessibility analysis. Our ability to evaluate accessibility is improving as transportation and land use planners develop better tools for quantifying accessibility impacts, including multi-modal level-of-service indicators, and models which measure the travel distances, travel time and travel costs required by various types of transport system users to access various types of services and activities. However, accessibility-based planning techniques are still new and practitioners are still learning how to apply them to specific decisions. Comprehensive accessibility analysis therefore requires creativity and judgment to incorporate new accessibility factors.

Table ES-1 lists factors indicates factors that affect accessibility, how they are currently considered, and potential improvements for more comprehensive planning. This information can be used to critique and improve planning.

Table ES-1 Summary of Factors Affecting Accessibility

Name	Description	Current Consideration	Improvements
Transport Demand	The amount of mobility and access that people would choose in specific conditions.	Motorized travel demand is well measured, but other modes are not.	More comprehensive travel surveys, statistics and analysis of travel demands.
Automobile travel	Automobile travel speeds, convenience, and affordability.	Often considers speed, delay and parking convenience.	Consider other vehicle impacts including affordability and risk.
Transport system diversity (mobility options)	The quality (speed, convenience, comfort, safety, etc.) of transport options including walking, bicycling, public transport, etc.	Some models apply multimodal LOS analysis, but many factors are often overlooked.	More multi-modal evaluation (speed, convenience, comfort, safety, etc.) of walking, bicycling, public transit, taxi and ridehailing, etc.
Roadway network connectivity	Density of roadway connections and therefore the directness of travel between destinations.	Some models consider roadway connectivity impacts on accessibility.	More comprehensive analysis of roadway connectivity.
Transport network connectivity	The degree of integration among transport modes.	Connectivity for automobiles is well measured other modes is often overlooked.	More integrated analysis of connectivity among non-auto modes.
Proximity (Land Use Factors)	The distances between activities, and therefore development density and mix.	Usually considered in land use planning, but less in transport planning.	More comprehensive analysis of land use accessibility.
Mobility Substitutes	Telecommunications and delivery services that substitute for physical travel.	Not usually considered in transport planning.	Consider mobility substitutes as part of the transport planning.
User information	Availability of reliable information on mobility and accessibility options.	Sometimes considered for particular modes or locations, but seldom comprehensive.	More comprehensive and integrated information to help users navigate transport systems.
Affordability	The cost to users relative to their incomes.	Automobile operating costs and transit fares are usually considered.	More comprehensive evaluation of transport costs relative to users incomes.
Transport system management	Whether transport systems are managed to favor higher value trips and more efficient modes.	Little consideration.	Apply transport management strategies to increase system efficiency.
Inaccessibility	The value of inaccessibility and isolation.	Not generally considered in transport planning.	Recognize the value of limiting access when appropriate.

This table indicates factors that affect accessibility and how they are considered in a planning process.

There is considerable potential for improvement (Levinson and King 2020). New analysis tools, such as the [Housing and Transportation Affordability Index](#), the [Smart Location Mapping Website](#), and [Street Smart](#), provide practical guidance for comprehensive accessibility evaluation.

Introduction

Transportation planning is experiencing a *paradigm shift* (a fundamental change in how problems are defined and solutions evaluated) (Litman 2013). This involves a change from *traffic-based analysis* (which evaluates transportation system performance based on motor vehicle travel speeds and operating costs), to *mobility-oriented analysis* (which evaluates transport system performance based on persona and freight travel speed and costs), to *accessibility-based analysis* (which evaluates transport system performance based on people and businesses' ability to reach desired services and activities). These are nested concepts – traffic is a subset of mobility, and mobility is a subset of accessibility – as illustrated below.

Figure 1 Traffic, Mobility and Accessibility (Litman 2003)

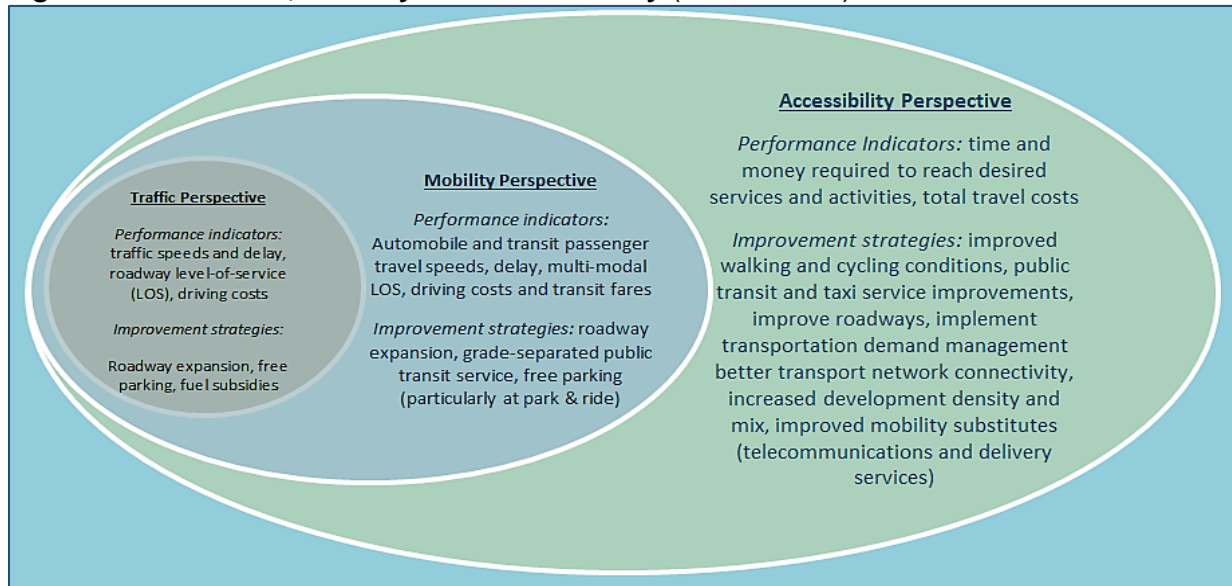

Transportation can be viewed from various perspectives: **vehicle traffic** is a subset of **mobility**, which is a subset of **accessibility**. Accessibility is the broadest perspective and so offers the most potential solutions to transport problems, including more accessible land use development and mobility substitutes such as improved telecommunications and delivery services.

Access is the ultimate goal of most travel activity, so accessibility-based planning tends to best reflect what users want from a transportation system, and offers the widest range of potential solutions to transport problems. For example, mobility-based planning assumes that the solution to traffic congestion is to expand roadways to accommodate more vehicle traffic; accessibility-based planning can also consider improvements to non-auto modes, transportation demand management incentives to shift from automobiles to space-efficient modes, Smart Growth development policies that reduce travel distances, and mobility substitutes such as telecommunications and delivery services that reduce the need for physical travel.

Accessibility can be evaluated from various perspectives. It is often measured for particular users, modes, activities, locations, times and scales, such as the numbers and types of jobs or stores accessible to low-income non-drivers living in a particular neighborhood, or aggregated to measure multiple people's ability to access multiple services and activities in an area (Levinson and Wu 2020). It can be measured at neighborhood, regional or interregional scales.

Many people now apply accessibility-based planning, although they may not use the term. For example, many households and communities want *15-minute neighborhoods*, meaning that commonly-used services and activities can be reached within a 15-minute walk or bike ride, in other words, designed to maximize active mode accessibility (Duany and Steuteville 2021).

This has many implications for planning. It changes how we think about and measure transport problems and the scope of solutions that are considered for addressing them. As with the Copernican revolution, this shift changes what we consider the system's center: traffic-based planning places *motor vehicles* at the center, while accessibility-based planning places *people* at the center of the transport system.

Many current planning practices favor mobility over accessibility and automobile travel over alternative modes. For example:

- Transport system performance is often evaluated based on travel speed and distance, which favors faster modes and quantitative improvements over slower modes and qualitative improvements (such as increased passenger convenience and comfort).
- Travel statistics often undercount and undervalue nonmotorized travel by ignoring short trips, children's travel, non-commute trips, and non-motorized links of motorized trips.
- The benefits from increased vehicle traffic volumes and speeds are recognized, but reductions in walkability and land use accessibility are often overlooked.

Such planning practices can result in decisions that increase mobility but reduce overall accessibility (for example, by reducing travel options and stimulating sprawl), and tend to undervalue other accessibility improvement options (such as more accessible land use development, and mobility substitutes such as telework). More comprehensive analysis can help decision-makers identify more optimal solutions. However, evaluating accessibility is challenging. Different planning issues require different methods to account for different users, modes, scales and perspectives. For example, neighborhood planning requires more walkability analysis, while regional planning requires more analysis of automobile, bus and rail travel.

This report provides guidance for applying various types of accessibility analysis in transport planning. It defines the concept of accessibility, describes factors that affect people's ability to reach destinations and perspectives to consider, discusses evaluation methods, and describes options for improving access. This document should be useful to transport planners, modelers and decision-makers.

Defining Accessibility

Accessibility (or just *access*) refers to the ease of reaching goods, services, activities and destinations, which together are called *opportunities*. It can be defined as the potential for *interaction* and *exchange* (Hansen 1959; Engwicht 1993). For example, grocery stores provide access to food. Libraries and the Internet provide access to information. Paths, roads and airports provide access to destinations and therefore activities (also called *opportunities*). Accessibility can be defined in terms of *potential* (opportunities that could be reached) or in terms of *activity* (opportunities that are reached). Even people who don't currently use a particular form of access may value having it available for possible future use, called *option value*. For example, motorists may value having public transit services available in case they are unable to drive in the future.

Access is the goal of most transport activity, except the small portion of travel for which mobility is an end in itself (e.g., jogging, cruising, leisure train rides). Even recreational travel usually has a destination, such as a resort or campsite. Various disciplines analyze accessibility, but their perspective is often limited:

- Transport planners generally focus on mobility, particularly vehicle travel.
- Land use planners generally focus on geographic accessibility (distances between activities).
- Communications experts focus on telecommunication quality (such as the portion of households with access to telephone, cable and Internet services).
- Social service planners focus on accessibility options for specific groups to specific services (such as disabled people's ability to reach medical clinics and recreation centers).

Other Meanings

The words *accessibility* and *access* can have various meanings and implications.

- *Accessibility* generally refers to *physical access* to goods, services and destinations, which is what people usually mean by *transportation*.
- In roadway engineering, *access* refers to connections to adjacent properties. *Limited access* roads have minimal connections to adjacent properties, while local roads provide direct access. *Access management* involves limiting intersections and driveways on highways.
- In the fields of geography and urban economics, *accessibility* refers to the relative ease of reaching a particular location or area.
- In pedestrian planning and facility design *accessible design* (also called *universal design*) refers to facilities designed to accommodate people with disabilities. For example, a pathway designed to accommodate people in wheelchairs may be called *accessible*.
- In social planning, *accessibility* refers to people's ability to use services and opportunities.

How transportation is evaluated can affect planning decisions. For example, if transportation is evaluated based on *vehicle travel conditions* (traffic speeds, congestion delay, roadway Level-of-Service ratings), the only way to improve transport system quality is to improve roadways. If transportation is evaluated based on *mobility* (movement of people and goods), then rideshare and public transit service improvements can also be considered. If transportation is evaluated based on *accessibility* (people's ability to reach desired goods, services and activities), additional

options can be considered besides roadway, rideshare and public transit, including improved walking and cycling conditions, more accessible land use patterns to reduce travel distances, and telecommunications and delivery services that substitute for physical travel. Table 1 compares these perspectives.

Table 1 Transportation Evaluation Perspectives (Litman 2003)

	Vehicle Travel	Mobility	Accessibility
Definition of Transportation	Vehicle travel	Person and goods movement	Ability to obtain goods, services and activities
Measurement units	Vehicle miles	Person-miles and ton-miles	Trips, generalized costs
Modes considered	Automobile and truck	Automobile, truck and transit	Automobile, truck, transit, cycling and walking
Common indicators	Vehicle traffic volumes and speeds, roadway Level of Service, costs per vehicle-mile, parking convenience	Travel distance and speeds, road and transit Level of Service, cost per person-mile, travel convenience	Quality of available transportation choices. Distribution of destinations. Cost per trip
Consumer benefits considered	Maximum motor vehicle travel and speed	Maximum personal travel and goods movement	Maximum transport choice and cost efficiency
Consideration of land use	Treats land use as an input, unaffected by transportation decisions	Recognizes that land use can affect travel choice	Recognizes that land use has major impacts on transportation
Favored transportation improvement strategies	Roadway and parking facility improvements to increase capacity, speed and safety	Transportation system improvements that increase capacity, speeds and safety	Management strategies and improvements that increase transport system efficiency and safety
Transportation Demand Management (TDM)	Generally considers vehicle travel reductions undesirable	Supports TDM strategies that improve personal and freight mobility	Supports TDM whenever it is cost effective

This table compares three common perspectives used to measure transportation.

Accessibility-based analysis therefore expands the range of possible solutions to transport problems, which can lead to better solutions. For example, if a school experiences traffic or parking congestion problems, vehicle-travel-based analysis would conclude that roads and parking facilities must be expanded. Mobility-based analysis may consider school busing improvements as a possible solution. Accessibility-based analysis can consider a wider range of factors, including walking and cycling improvements, incentives to encourage students and staff to reduce their vehicle trips, and smart growth policies that reduce the distances between student’s homes and schools. Accessibility-based solutions are often provide co-benefits, besides congestion reductions, and so are most cost effective overall, considering all benefits and costs.

Factors That Affect Accessibility

This section describes specific factors that affect accessibility and how they should be evaluated.

Transportation Demand and Activity

Transportation demand refers to the amount of mobility and accessibility people would consume under various conditions. *Transportation activity* refers to the amount of mobility and accessibility people actually experience. People typically make 2-4 daily trips outside their home, with higher levels of demand for people who commute to school or jobs, care for dependents (such as children or disabled adults), and have higher incomes. Some people, particularly those with disabilities, tend to have significant latent travel demand, that is, they would like to take more trips outside their homes (Mattson 2012). Travel demand can be categorized in various ways:

- *Demographics* (age, income, employment status, gender, etc.)
- *Purpose* (commuting, personal errands, recreation, etc.).
- *Destination* (school, job, stores, restaurants, parks, friends, families, etc.). These can be divided into *common* destinations (goods and services available at many locations) and *unique* destinations (activities at a particular destination, such as a friend's house).
- *Time* (hour, day, season).
- *Mode* (walking, cycling, automobile driver, automobile passenger, transit passenger, etc.). *Mode share* (the portion of trips made by different modes) is affected by factors such as vehicle availability, the quality of alternative modes and community design.
- *Distance* (from origin to destination, and from origin to access each mode, such as walking distance to transit stations).

Most people consider a certain amount of mobility desirable (Mokhtarian and Salomon 2001; Colonna 2009), including walking, cycling, driving and public transit (Handy, 1993). People enjoy certain travel activities, such as drives in the countryside, holiday trips. Even utilitarian trips, such as errands and commuting, may be longer than necessary due to travel enjoyment. However, travel time research indicates that most people would prefer to devote less time to travel ("Travel Time Costs," Litman 2006a).

Implications:

- Demographic and geographic factors affect demand for mobility and access. Attending school, being employed, or having dependents increases demand.
- Price, quality and other factors affect demand for each mode and therefore mode split.
- As accessibility improves people tend to access more opportunities.
- Under some circumstances, time spent traveling has little or no cost.

Mobility

Mobility refers to physical movement, measured by trips, distance and speed, such as person-miles or –kilometers for personal travel, and ton-miles or tonne-kilometers for freight travel. All else being equal, increased mobility increases accessibility: the more and faster people can travel the more destinations they can reach.

Conventional planning tends to evaluate transport system quality primarily based on mobility, using indicators such as average traffic speed and congestion delay (Litman 2001). However, efforts to increase vehicle traffic speeds and volumes can reduce other forms of accessibility, by constraining pedestrian travel and stimulating more dispersed, automobile-oriented development patterns. Improving high occupant vehicle (HOV) travel and favor it over driving can reduce congestion increase personal mobility (person-miles of travel) without increasing vehicle mobility (vehicle-miles of travel).

Different modes have different speeds and different scales of accessibility (Krizek, et al. 2009). For example, in 5 minutes a typical pedestrian can walk about a ½ mile and so can access 36 square blocks, while a cyclist can travel about one mile and access 256 square blocks, and a motorist can travel 2 miles and access 2,500 square blocks.

Figure 1 Accessible by Different Modes

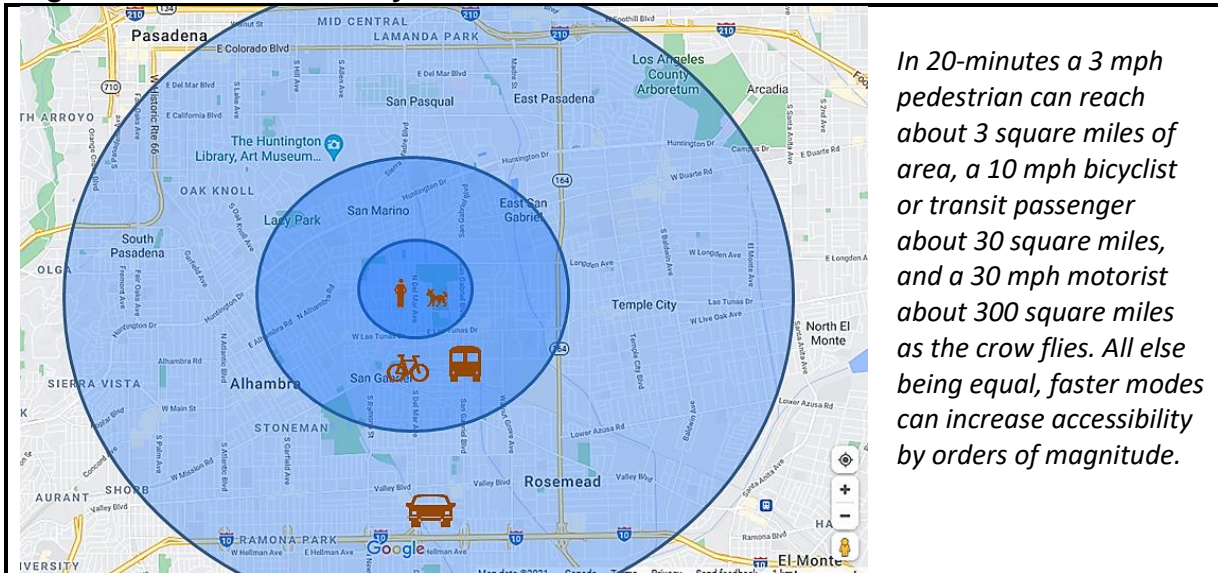

Implications:

- More and faster travel increases accessibility.
- Congestion can limit accessibility by a particular mode.
- Efforts to increase automobility can reduce other forms of accessibility.
- Higher occupancy modes can increase personal mobility without increasing vehicle travel.

Transportation Options

Transportation options (also called mobility options, transport diversity and transport choice) refer to the quantity and quality of transport modes and services available in a particular situation. Improving transport options improves accessibility. Modes differ in their capabilities and limitations, as summarized in Table 2, and so are most appropriate for serving different demands. For example, active modes (walking and cycling) are most appropriate for shorter trips, public transit is most appropriate for longer trips on major urban corridors, and automobiles are most appropriate for trips that involve heavy loads and dispersed destinations.

Table 2 Suitability of Transport Modes

Mode	Non-Drivers	Poor	Handi-capped	Limitations	Most Appropriate Uses
Walking	Yes	Yes	Varies	Requires physical ability. Limited distance and carrying capacity. Difficult or unsafe in some areas.	Short trips by physically able people.
Wheelchair	Yes	Yes	Yes	Requires sidewalk or path. Limited distance and carrying capacity.	Short urban trips by people with physical disabilities.
Bicycle	Yes	Yes	Varies	Requires bicycle and physical ability. Limited distance and carrying capacity.	Short to medium length trips by physically able people on suitable routes.
Taxi	Yes	Limited	Yes	Relatively high cost per mile.	Infrequent trips, short and medium distance trips.
Fixed Route Transit	Yes	Yes	Yes	Destinations and times limited.	Short to medium distance trips along busy corridors.
Paratransit	Yes	Yes	Yes	High cost and limited service.	Travel for disabled people.
Auto driver	No	Limited	Varies	Requires driving ability and automobile. High fixed costs.	Travel by people who can drive and afford an automobile.
Ridesharing (auto passenger)	Yes	Yes	Yes	Requires cooperative motorist.	Trips in which motorists can carry additional passengers.
Carsharing (Vehicle Rentals)	No	Limited	Varies	Requires convenient and affordable vehicle rentals services.	Occasional use by drivers who don't own an automobile.
Motorcycle	No	Limited	No	Requires riding ability and motorcycle. High fixed costs.	Travel by people who can ride and afford a motorcycle.
Telecommute	Yes	Varies	Varies	Requires equipment and skill.	Suitable for some types of trips.

Each mode is suitable for certain purposes.

The quality of different modes can be evaluated using various *level-of-service* (LOS) ratings, which grade service quality from A (best) to F (worst). Conventional planning tends to evaluate transport system quality based primarily on automobile travel conditions, but similar ratings can be applied to other modes, as indicated in Table 3 (Litman 2007b). For example, Minocha, et al. (2008) evaluate transit employment accessibility using an index of transit service quality (frequency and station quality) and transit travel times to employment areas. Owen and Levinson (2014) measure home-to-work door-to-door travel times by walking-cycling-transit for 46 of the 50 largest metropolitan areas in the United States.

Walking is a particularly important mode, both by itself and to provide access to motorized modes, including parked cars and public transit. Walkability indicators are an important but often undervalued accessibility factor (Pajares, et al. 2021; Rowlands 2020).

Table 3 Multi-Modal Level of Service

Mode	Level of Service Factors
Universal design (disability access)	Degree to which transport facilities and services accommodate people with disabilities and other special needs.
Walking	Sidewalk/path quality, street crossing conditions, land use conditions, security, prestige.
Cycling	Path quality, street riding conditions, parking conditions, security.
Ridesharing	Ridematching services, chances of finding rideshare matches, HOV priority.
Public transit	Service coverage, frequency, speed (particularly compared with driving), vehicle and waiting area comfort, user information, price, security, prestige.
Automobile	Speed, congestion delay, roadway conditions, parking convenience, safety.
Telework	Employer acceptance/support of telecommuting, Internet access.
Delivery services	Coverage, speed, convenience, affordability.

This table indicates specific factors for evaluating the service quality of various transport modes.

Leigh, Scott and Cleary (1999) developed *mobility gap* analysis, defined as the amount of additional transit service required for vehicle-lacking households to enjoy mobility levels comparable to vehicle-owning households. This is a conservative estimate because it does not account for unmet mobility needs of non-drivers in vehicle-owning households. Only about a third of transit needs are currently being met in the typical areas they evaluated, indicating a level of service (LOS) rating D, based on ratings shown in Table 4. The approach can be used to predict the LOS rating that will occur under various transit planning and investment scenarios.

Table 4 Transit Level Of Service Ratings (Leigh, Scott & Cleary 1999, p. VIII-3)

Portion Demand Met	Transit Level-Of-Service	Portion Demand Met	Transit Level-Of-Service
90% or more	A	25-49%	D
85-89%	B	10-24%	E
50-74%	C	Less than 10%	F

Sometime, a particular factor significantly affects accessibility. For example, inadequate information or poor security around transit stations can constrain transit use (potential riders don't know how to use it or have exaggerated fears of discomfort and risk).

Implications:

- Improving transport options tends to improve accessibility. Improvements can include increased convenience, speed, comfort, affordability, security, user information and prestige.
- Destinations served by more modes or better quality service tend to have better access.
- Evaluating accessibility requires detailed understanding of people's access needs and abilities, travel mode constraints, and the quality of service at a destination.
- Walking is the most basic travel mode so walkability is an important factor in overall accessibility.

User Information

The quality of information can affect the functional availability and desirability of mobility and accessibility options. For example, motorists need accurate and convenient information on travel routes, roadway conditions (such as when congestion, construction and accidents delay traffic), vehicle services, and the availability and price of parking. Potential transit users need information on transit routes, schedules, fares, comfort factors (such as whether vehicles will have seats or stations will have washrooms), and access to destinations. Walkers and cyclists need information on recommended routes, and cyclists need information on parking options. Information on destinations (such as whether a store offering a particular good is within convenient walking distance) can also affect accessibility.

There are many ways to provide transportation information, including maps, brochures, websites, social media and telephones systems. New communications systems can significantly improve transportation user information, including in-vehicle navigation systems for motorists, websites with detailed transit route and schedule information, real-time information on transit vehicle location and arrival (websites accessible by mobile telephone, and monitors at transit stops, can indicate the number of minutes until a particular bus or train will arrive at a particular location), and various scale maps and guides for pedestrians and cyclists. The effectiveness of such information depends on how well potential users are aware of, can access, and actually apply this information.

Implications:

- The availability and accuracy of user information affects accessibility.
- In many situations, improving user information is a cost effective way of improving accessibility.
- The effectiveness of such information depends on how well potential users are aware of, can access, and actually apply information.

Integration, Terminals and Parking

Accessibility is affected by the quality of system integration, such as the ease of transferring between modes, the quality of stations and terminals, and parking convenience.

Automobile transportation is generally well integrated. Most destinations have abundant and generally free or low-priced parking, and most transfer stations (airports, train and bus stations, ferry terminals and ports) are located and designed for convenient highway access, vehicle parking and often vehicle rental services. Motorists generally have good information through signs and maps.

The integration of other modes varies significantly, and inadequate integration is sometimes a major barrier to non-automobile accessibility. For example, airports and ferry terminals are sometimes difficult to access by public transit, and bus stops and train stations are sometimes uncomfortable and difficult to access, particularly by people with disabilities, children, and people carrying heavy loads. Some destinations lack suitable bicycle parking and changing facilities. It is often difficult to obtain accurate information on alternative modes.

Implications:

- The connections between links and modes affect accessibility.
- The location and quality of transportation terminals affects the accessibility of the modes they serve. The quality of bus stops, train stations, ferry terminals and other transfer facilities affects the relative accessibility of these modes.
- The availability, price and convenience of parking affect automobile accessibility.
- Bicycle transportation is facilitated by appropriate bicycle parking and storage facilities (including some covered and secure parking), and changing facilities at worksites.

Price and Affordability

Transportation affordability refers to the financial costs of travel relative to incomes, particularly lower-income residents' ability to afford access to basic (essential) services and activities. Motorists are primarily affected by the affordability of driving, while non-drivers are more affected by the affordability of other modes such as public transit, taxi and carsharing services.

Transportation affordability can be evaluated in several ways (Fan and Huang 2011). Many experts define affordability as households spending less than 45% of their total budget on housing and transportation combined, which recognizes that households often make trade-offs between housing and transportation expenses, and that an inexpensive rural house is not truly affordable if it has high transportation costs, and a household can rationally spend more to live in an accessible location where their transportation costs are low (CNT 2008).

Planning generally recognizes certain transportation affordability factors, such as vehicle operating costs (fuel prices, road tolls and parking fees) and transit fares, but tends to overlook other factors, particularly the importance of nonmotorized modes, modal integration (such as delivery services that help people shop by walking, cycling and public transit) and location factors. In particular, current planning practices sometimes restrict development of affordable housing, forcing lower-income people to live in automobile-dependent locations where they bear excessive transportation costs.

Implications:

- Affordability affects accessibility.
- Affordability is especially a problem for lower-income workers.
- Affordability can be improved by reducing user costs (vehicle purchase costs, fuel prices, transit fares, etc.), by improving more affordable modes (such as walking, cycling and public transit), and by increasing land use accessibility.
- Location affects transport affordability. Lower-income residents in automobile-dependent locations tend to spend an excessive portion of their income on transport.

Mobility Substitutes

Mobility substitutes include *telework* (telecommunications that substitutes for physical travel) and delivery services that provide access with minimal mobility (“Telework,” VTPI, 2006). Mobility substitutes can provide access for many goods and activities. For example, one way to improve access to information is to provide high-speed internet service, and arrange convenient and inexpensive delivery of library books directly to homes. Similarly, pharmacies may deliver medicines and other medical goods, rather than requiring customers to travel to a store.

However, there are limits to mobility substitute benefits. Many jobs and employees are unsuitable for telecommuting. Although it may be possible to purchase goods online, it is usually less satisfying than visiting a store where the physical goods can be examined. And an email, no matter how articulate, can never substitute for some physical interactions; mobility substitutes are often less productive and satisfying than physical access.

Mobility substitutes do not necessarily eliminate vehicle travel; in some situations they stimulate additional mobility by allowing more dispersed development and longer commute trips. For example, when given permission to telecommute two or three days a week, some employees use the opportunity to choose more distant home or employment locations, and telecommuters often make additional vehicle trips to run errands that would otherwise be made during while commuting, or to attend meetings or visit friends.

Mobility substitutes can complement other alternative modes. For example, Internet transit schedules can improve transit service, and delivery services can help people shop by walking, cycling and public transit. Mobility substitutes can be particularly effective at reducing vehicle travel if implemented as part of a comprehensive mobility management program that improves travel options and discourages driving.

Most mobility substitutes enjoy economies of scale. For example, high-speed Internet services and most delivery services require a minimal level of demand in a particular area to be cost effective, and as demand increases the quality of service will increase. This may justify subsidies or other favorable public policies to stimulate demand.

Implications:

- Mobility substitutes can provide access to certain types of activities (primarily involving information exchange), certain types of goods (suitable for shipping), and certain types of users (people who are comfortable using telecommunications equipment).
- Mobility substitutes do not eliminate the need for other types of access, and by themselves may stimulate motorized travel by supporting more dispersed housing and long-distance commutes.
- Mobility substitutes can complement alternative modes, reducing vehicle travel. For example, delivery services allow people to shop by walking, cycling and public transit.

Land Use Factors

Various *land use* (also called *geographic, urban form* and *built environment*) factors affect accessibility (Litman 2005), including density, mix, connectivity and walkability. *Smart growth*, a more accessible land use pattern, means that less mobility is needed to reach activities and destinations. A typical household's accessibility can be envisioned as a triangle connecting home, work and services. Travel distances and options among these destinations affect overall accessibility. For example, improving the variety of services (shops, schools, restaurants, parks, etc.) within a neighborhood or worksite, and improving travel options from home to worksite, tends to increase accessibility and reduce transport expenditures.

Let's say you typically visit a dozen destinations each week (e.g., worksite, stores, friends, video rental, bookshop, department store, pharmacy, camera shop). Say these destinations are evenly located along a road with your home at one end, as in Figure 2. The more dispersed your destinations, the more travel is required to reach them. If destinations average a half-mile apart, your travel requirements will be half as far as if they average 1 mile apart. If destinations are very close together (say, averaging one or two blocks apart), you can reach them by walking or transit and walking.

Implications:

- Increased density and clustering of activities tends to increase accessibility.
- Shorter travel distances can improve transport options (particularly walking).

Figure 2 Accessibility From A Location At One End Of A Roadway

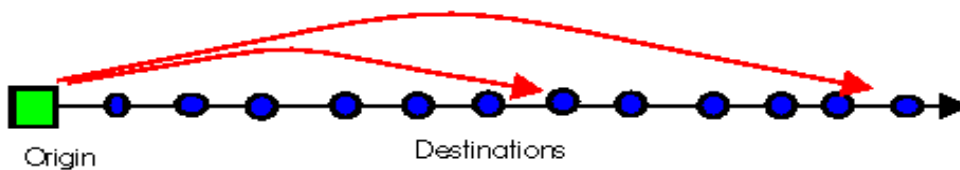

As destinations are located closer together along a roadway, accessibility increases. If destinations are close enough together, they can be reached by walking.

Accessibility increases with closer destinations (Figure 2) and more central locations (Figure 3), because this reduces the average distance to each destination.

Figure 3 Accessibility From A Central Location On A Roadway

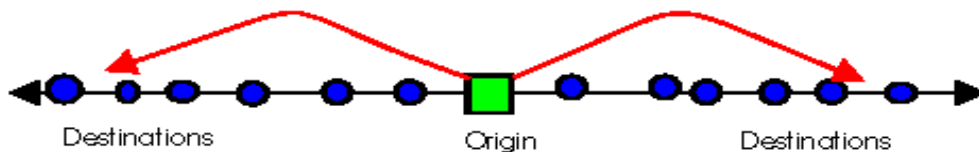

A more central location reduces travel requirements, increasing accessibility.

Accessibility can increase if the two ends of a road are connected (a simple form of increased *connectivity*), as in Figure 4, because this may allow you to travel in a loop and avoid backtracking for some types of trips.

Figure 4 Accessibility From A Location On A Loop Road

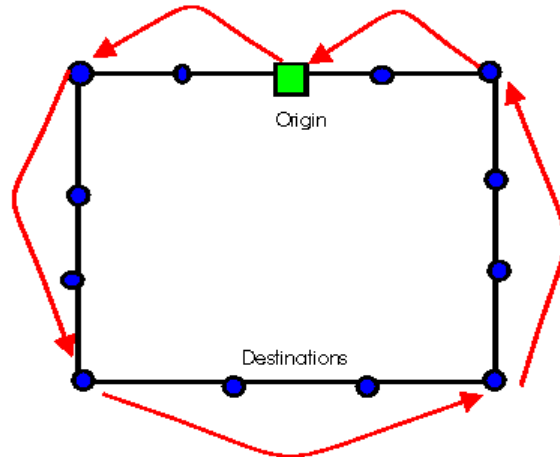

A connected loop increases route options, increasing accessibility.

Figure 5 Accessibility From A Crossroads

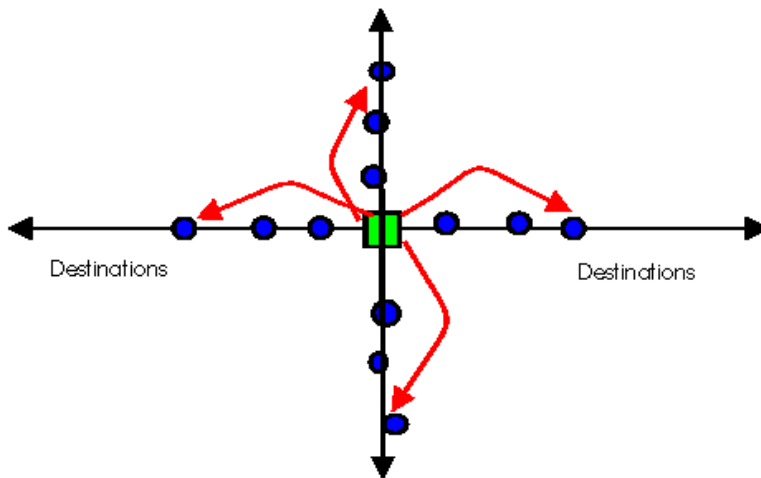

Locating at a crossroads reduces travel requirements, increasing accessibility.

Accessibility increases at a crossroads with destinations in each direction, as in Figure 5. Side roads that link destinations, as illustrated in Figure 6, increase accessibility by allowing more direct travel between destinations.

Figure 6 Accessibility From A Crossroads With Connections

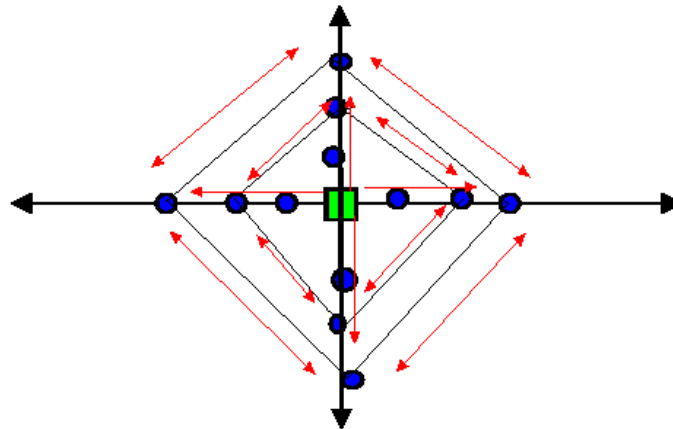

As the number of roadway connections increases so do route options, increasing accessibility.

Implications:

- A more central location increases accessibility.
- A more connected road network increases accessibility.

Density refers to the number of people or jobs per acre. *Clustering* refers to people and activities locating together. Density and clustering are somewhat different concepts. Low-density areas can have a high degree of clustering, such as rural residents and businesses locating in villages. *Land use mix* refers to various land uses (residential, commercial, institutional, recreational, etc.) located close together. Land use density, clustering and mix tend to increase accessibility. For example, a neighborhood or activity center with housing, stores, offices and transport services located close together provides a high level of accessibility, as illustrated in Figure 7.

Figure 7 Accessibility With Clustering Of Destinations

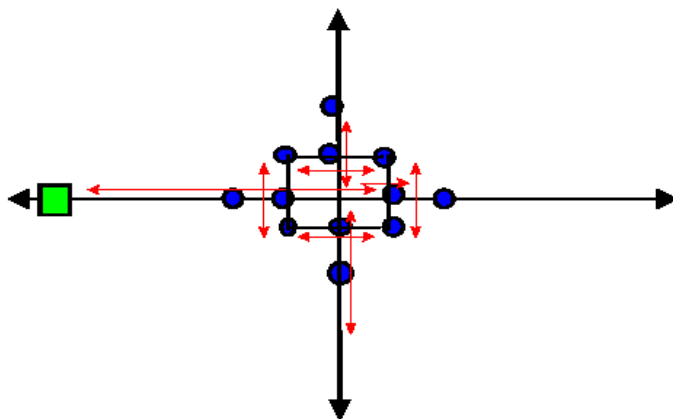

Clustering increases access to common activities, particularly by walking and public transit.

Figure 8 illustrates how multi-story buildings can stack destinations on top of each other to achieve greater density and accessibility. Accessibility tends to be greatest on ground floors, because they are directly connected to sidewalks and parking facilities.

Figure 8 Accessibility With Vertical Clustering

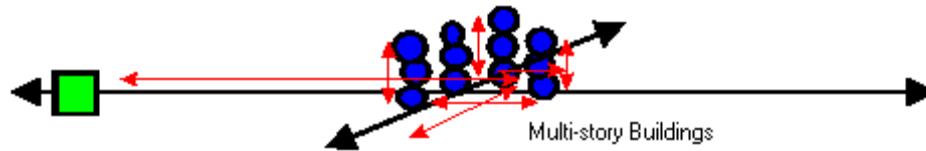

Vertical clustering (multi-story buildings) can increase accessibility.

Certain types of activities experience agglomeration economies, that is, they become more efficient and productive if located close together. Many businesses and industries become more productive if located in a commercial center (downtown or mall) close to customers and services. For example, a lawyer becomes more productive if there are plenty of clients nearby, and services such as photocopy shops and accountants are nearby. Similarly, a software industry tend to be more productive if numerous related businesses (programmers, graphic design, digital music, hardware suppliers, specialized law and accounting firms) are located close together.

The relationship between density and accessibility is complex, because increased density and clustering can increase traffic and parking congestion, which reduces automobile accessibility. Other modes, such as walking and public transit, require less space and benefit from density. Clustering activities into a compact center (such as a downtown or mall) makes it feasible to perform numerous errands with one vehicle trip, which is helpful to motorists and even more helpful to transit users.

Implications:

- Clustering and mixing of common destinations increases accessibility. Having common destinations within walking distance (less than a mile) significantly increases accessibility.
- Generous parking supply tends to improve automobile access but can reduce accessibility by other modes.
- Clustering transportation services into centers and terminals increases accessibility.
- Increasing building height or reducing the amount of land around buildings devoted to parking can increase density and accessibility.
- Certain types of clustering can provide economies of agglomeration.
- Density and clustering may create vehicle traffic and parking congestion, but this may be offset if increased accessibility and transportation diversity reduce vehicle traffic.

Transportation Network Connectivity

Connectivity refers to the density of connections within a transport network. Increased connectivity tends to increase accessibility. A dense path or road network (Figure 9) with shorter blocks and more connections tends to provide good accessibility due to multiple routes, more direct connections between destinations, and narrower streets with lower traffic speeds that are better suited to walking and cycling, and therefore to public transit travel (since most transit trips involve walking links). Similarly, two-way streets tend to provide more direct access to destinations than one-way streets (Gayah 2012).

Figure 9 Accessibility On Grid Road Network

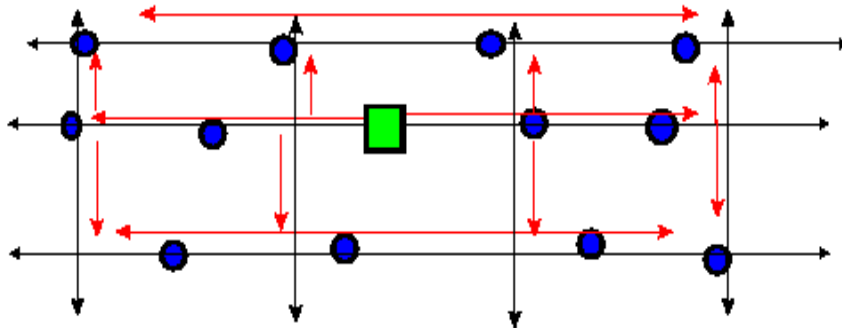

A traditional grid network has many connected roads, providing multiple, direct route choices. This tends to reduce trip distances, increase travel choice, reduce congestion, and increase accessibility.

A hierarchical road network (Figure 10), with many dead-end streets connected by wide arterial roads, tends to have higher average traffic speeds but lower overall accessibility due to longer travel distances (since routes are more circuitous), increasing congestion (since traffic is concentrated on arterials), and poor walking and cycling conditions (due to wider roadways and higher speed traffic).

Figure 10 Accessibility With Hierarchical Road Network

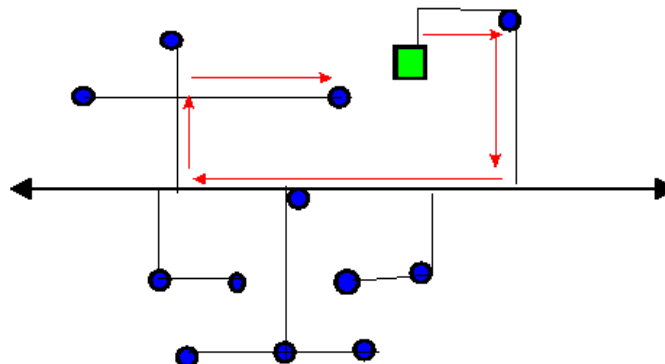

A hierarchical road network channels traffic onto a few major arterials, even for travel between destinations located near to each other. This tends to reduce accessibility, increase congestion and reduce travel options (particularly walking). This roadway design is common in suburban communities.

Cul-de-sac streets are popular because they constrain traffic. An alternative approach is a *modified grid* with connected streets with short blocks and T-intersections to limit traffic speeds, as illustrated in Figure 11. This limits traffic while still allowing more direct routes between destinations. This can be improved further by incorporating paths (dashed lines) that improve access for walking and cycling. Traffic calming can control excessive traffic in older neighborhoods with grid street, as advocated by New Urbanist planners.

Figure 11 Accessibility On Modified Grid Road And Path Network

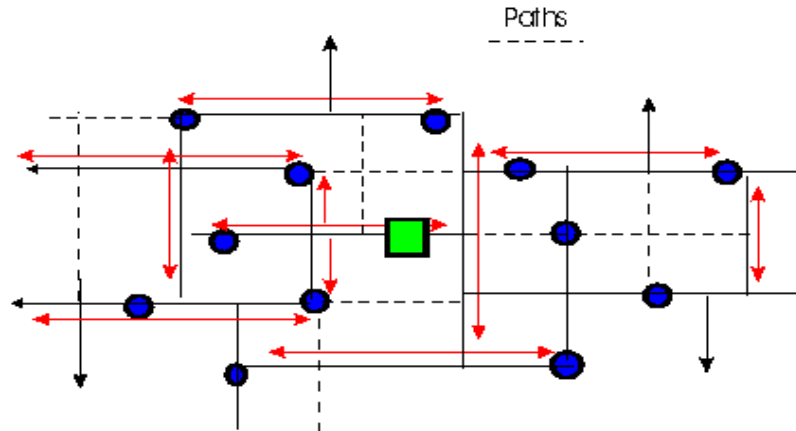

A modified grid has many connected roads designed with short blocks and T-intersections to limit traffic speeds. Paths create shortcuts for walking and cycling. This provides good accessibility, creates a more livable neighborhood and encourages nonmotorized transport.

Implications:

- A hierarchical street system with traffic channeled onto major arterials tends to reduce access, increase congestion and degrade nonmotorized travel conditions.
- Two-way streets provide more connectivity than one-way streets.
- A grid or modified-grid street system provides more direct access to destinations.
- Pedestrian paths and shortcuts can improve nonmotorized accessibility.

Connectivity Index

A *Connectivity Index* evaluates how well a roadway network connects destinations (Ewing, 1996). It is computed by dividing the number of roadway links by the number of roadway nodes. Links are the segments between intersections, and the nodes are the intersections themselves. Cul-de-sac heads count the same as any other link end point. The result can be calculated separately for pedestrian and cycling access, taking into account connections and links for non-motorized travel, such as a path that connects the ends of two cul-de-sacs.

A higher index means that travelers have increased route choice, allowing more direct connections for access between any two locations. According to this index, a simple box is scored a 1.0. A four-square grid scores a 1.33 while a nine-square scores a 1.5. Deadend and cul-de-sac streets reduce the index value. This sort of connectivity is particularly important for nonmotorized accessibility. A score of 1.4 is the minimum needed for a walkable community.

Transportation System Management

Various transportation system management factors can affect mobility and accessibility. Transportation Demand Management (TDM) strategies include various policies and programs that encourage more efficient use of transportation resources, such as targeted improvements and incentives to encourage commuters to use space-efficient modes, and freight transport management programs that result in more efficient shipping (SSTI 2018).

Roadway design decisions often involve tradeoffs between different forms of access. For example, roadway planners must often choose between allocating road space to general traffic lanes, bus lanes, bike lanes, parking lanes, sidewalks, utilities (such as telephone poles), street furniture, and other activities (such as landscaping and sidewalk cafes). Wider and straighter roads with minimum intersections and driveways tend to favor automobile travel, but may be difficult and unpleasant for walking and cycling, and therefore for public transit access. Conversely, design and management strategies, such as expanding pedestrian and cycling facilities, traffic calming, and traffic speed reductions, tend to benefit walking and cycling access, but reduce motor vehicle traffic speeds and capacity, reducing mobility.

Implications:

- Transportation demand management strategies can be used to increase transport system efficiency and address specific problems.
- Roadway design and management often involves tradeoffs between different forms of mobility and access.
- Roadway design and management can favor certain modes, users or locations.

Time and Coordination

In the book, *Spontaneous Access: Reflexions on Designing Cities and Transport*, Levinson (2016) emphasizes temporal components of accessibility, such as the need for people to coordinate connections for activities such as work, shopping and socializing. Some types of accessibility improvements tend to reduce time constraints and coordination requirements, allowing more flexible planning and spontaneous activities.

For example, new communications technologies such as mobile telephones allow people to plan trip real-time, changing route, mode and destination in response to travel conditions such as traffic congestion and transit delays, or based on changing information about where friends plan to meet. Similarly, as cities increase in size they tend to provide access to more diverse services, including some with longer hours that operate late at night and weekends, plus longer public transit operating hours which expand when people can access them; they can be considered 24-hour cities. Walking and public transit tend to encourage more spontaneous human interactions, since these modes allow people (typically friends and acquaintances) to connect in passing, sometime leading to unplanned conversations or visits, which could not occur when motorists pass on roadways. The increase in spontaneous interactions helps explain the attractiveness of walkable campuses for education and research organizations, and the increases in productivity and creative activities (such as art districts) in larger, walkable cities.

Implications:

- Many activities have temporal (time-based) constraints, so accessibility must account for time as well as location.
- There are efficiencies to reduced time constraints that increase spontaneous (less planned) activities.
- Economies of scale tend to reduce time constraints in urban areas.
- Walking and public transit tend to increase spontaneous human interactions.

Prioritization

Prioritization increases transport system efficiency by giving priority to higher value trips and more efficient modes:

- Pricing, which allows higher value travel to outbid lower value travel, based on consumers' willingness-to-pay. For example, road pricing allows higher value vehicle trips to out-bid lower value trips on congested roads, and parking pricing allows motorists access to more convenient parking spaces if they are willing to pay.
- Policies that favor *basic mobility* and *basic accessibility* (transport considered high value by society), such as priority for emergency and freight vehicles in traffic, transit subsidies and special mobility services that provides mobility for people who are transportation disadvantaged, travel to school and work, and universal design (facility and services designed to accommodate all types of users, including people with disabilities).
- High Occupant Vehicle (HOV) priority systems, which give more space-efficient vehicles, such as vanpools and buses, priority over space inefficient vehicles in traffic.
- Location-efficient planning, which encourages major traffic generators (such as employment centers, public services, and large residential buildings) to choose more accessible locations (such as near transit centers and highway intersections, and closer to major cities, as opposed to dispersed, automobile-dependent locations).
- Transportation planning practices that reflect economic efficiency principles, such as *least-cost planning* (funds are allocated to the transportation improvement options that are most cost effective overall, including alternative modes and demand management strategies), and *congestion pricing* (pricing designed to ration road space).

Prioritization increases the value of accessibility provided by a given amount of mobility and a given expenditure on facilities and services. For example, road and parking pricing allow vehicles making higher value trips to outbid lower value trips, and HOV priority strategies allow space efficient modes, such as vanpools and buses, to avoid congestion delays experienced by space inefficient modes. Without prioritization, large investments in roadway capacity expansion may provide virtually no reduction in traffic congestion (due to generated traffic), little net benefits to consumers (since much of the value is captured as a windfall to urban fringe land owners, who see their property values increase), and even negative net benefit to society as the increased vehicle travel increases external costs such as downstream congestion, accidents, pollution emissions and sprawl. Prioritization strategies such as congestion pricing and HOV lanes can improve accessibility while reducing total vehicle travel. Similarly, location-efficient land use development can increase overall accessibility while reducing mobility.

Various terms are currently used for transportation prioritization, including *traffic management* (which refers to strategies that improve traffic flow, such as ramp metering, reversible lanes and HOV priority), *transportation demand management (TDM)* and *mobility management*, which include various strategies that improve travel options, encourage use of efficient modes, and increase land use accessibility, as listed in Table 5. Because these strategies are intended to increase accessibility while reducing vehicle travel, they require accessibility-based analysis to evaluate their benefits.

Table 5 **Mobility Management Strategies (VTPI 2006)**

Improves Transport Options	Incentives for Efficiency	Land Use Management	Policy & Planning Reforms
Transit improvements			Commuter trip reduction programs
Walking and cycling improvements	Congestion pricing	Smart growth	School and campus transport management
Rideshare programs	Distance-based fees	New urbanism	Freight transport management
Flextime/Compressed workweek	Employee transportation benefits	Location-efficient development	Tourist transport management
Carsharing	Parking cash out	Parking management	Transit marketing
Telework	Parking pricing	Transit oriented development	Nonmotorized encouragement
Bike/transit integration	Pay-as-you-drive vehicle insurance	Car free planning	
Guaranteed ride home	Fuel tax increases	Traffic calming	

This table lists various types of mobility management strategies.

Prioritization tends to be most effective if implemented as part of an integrated mobility management program that improves travel options and land use accessibility. For example, road pricing and HOV lanes may fail to improve accessibility if implemented alone, but may provide significant net benefits if implemented in conjunction with ridesharing and transit service improvements on that corridor, and transit-oriented development in destination areas. Planning should therefore evaluate mobility management packages rather than individual strategies. When all impacts are considered, prioritization is often the most cost-effective way to improve accessibility because it increases the value provided by each unit of mobility. However, these benefits can be difficult to quantify using mobility-based evaluation, and so they tend to be undervalued by conventional transport planning.

Implications:

- Various prioritization strategies (often called *transportation demand management* or *mobility management*) can increase transport system efficiency by favoring higher value trips and more efficient modes. This increases the value provided by a given amount of mobility.
- Favoring basic mobility and accessibility tends to increase efficiency and social equity.
- Prioritization strategies affect the relative accessibility of different modes and locations.
- Prioritization is often the most cost-effective way to improve accessibility and addressing transport problems, but tends to be undervalued by conventional evaluation.
- Mobility management evaluation requires accessibility-based analysis which recognizes that some travel has more value than others.

Valuing Inaccessibility

Most transport planning assumes that increased accessibility and mobility provide net benefits to society. Yet, inaccessibility provides benefits and increased mobility often imposes significant external costs. For example, many people dream of living on an isolated rural community or island for the sake of quiet, privacy and community cohesion. Expanded transport facilities and increased vehicle traffic impose significant external costs (such as increased infrastructure costs, congestion, accident risk, neighborhood disruptions, energy consumption and pollution emissions) which may offset much of the benefits of increased mobility. Comprehensive analysis of accessibility and mobility should therefore account for these external costs, and not assume that increased accessibility and mobility are necessarily beneficial.

Many people want to live in a rural community but work and shop in a city. As a result, there is often significant demand for urban fringe accessibility improvements. Yet, this can spoil the amenities that urban fringe residents desire. Households that moved 10-miles from the city to enjoy rural life soon find their area is spoiled by development, so they must move further away, making willingness to drive a limiting factor. This trend continually expands the urban fringe and increases transport costs, exacerbating urban sprawl and transportation problems such as congestion, accidents and pollution.

Implications:

- Current planning generally fails to consider the disamenities associated with increased accessibility and the external costs of increased mobility, and so tends to overstate the benefits of increased access and mobility.
- To the degree that automobile travel is underpriced, current levels of motor vehicle travel will be economically excessive, and accommodating this demand is likely to be economically harmful.
- Communities may be better off limiting accessibility and mobility, particularly where isolation, quiet, independence and community cohesion are valued, and vehicle travel may impose significant externalities.

Summary of Factors Affecting Accessibility

The table below lists factors that affect accessibility, how they are currently considered, and possible improvements for more comprehensive transport and land use planning.

Table 6 Summary of Factors Affecting Accessibility

Name	Description	Current Consideration	Improvements
Transport Demand	The amount of mobility and access that people would choose in specific conditions.	Motorized travel demand is well measured, but other modes are not.	More comprehensive travel surveys, statistics and analysis of travel demands.
Automobile travel	Automobile travel speeds, convenience, and affordability.	Considers speed, delay and parking convenience.	Consider other vehicle impacts including affordability and risk.
Transport system diversity (mobility options)	The quality (speed, convenience, comfort, safety, etc.) of transport options including walking, bicycling, public transport, etc.	Some models apply multimodal LOS analysis, but many factors are often overlooked.	More multi-modal evaluation (speed, convenience, comfort, safety, etc.) of walking, bicycling, public transit, taxi and ridehailing, etc.
Roadway network connectivity	Density of road and path connections, and therefore the directness of travel between destinations.	Transport planning is starting to consider roadway connectivity impacts on accessibility.	More comprehensive analysis of roadway connectivity.
Transport network connectivity	The degree of integration among transport modes.	Connectivity to automobiles is well measured, but connectivity with other modes is often overlooked.	More integrated analysis of connectivity among non-auto modes.
Geographic proximity (Land Use Factors)	The distances between activities, and therefore development density and mix.	Usually considered in land use planning, but less in transport planning.	More comprehensive analysis of land use accessibility.
Mobility Substitutes	Telecommunications and delivery services that substitute for physical travel.	Not usually considered in transport planning.	Consider mobility substitutes as part of the transport planning.
User information	Availability of reliable information on mobility and accessibility options.	Sometimes considered for particular modes or locations, but seldom comprehensive.	More comprehensive and integrated information to help users navigate transport systems.
Affordability	The cost to users relative to their incomes.	Automobile operating costs and transit fares are usually considered.	More comprehensive evaluation of transport costs relative to users incomes.
Transport system management	Whether transport systems are managed to favor higher value trips and more efficient modes.	Little consideration.	Apply transport management strategies to increase system efficiency.
Inaccessibility	The value of inaccessibility and isolation.	Not generally considered in transport planning.	Recognize the value of limiting access when appropriate.

This table indicates factors that affect accessibility, how they are currently considered, and potential improvements for more comprehensive planning.

Perspectives

Accessibility can be viewed from various perspectives, such as a particular person, group, mode, location or activity. It is therefore important to specify the perspective being considered when evaluating accessibility. For example, a particular location may be very accessible to some modes and users, but not to others.

Individuals and Groups

Planning should account for different people and group’s differing accessibility needs and abilities, as indicated in Table 7. Some types of planning analysis focus on certain groups, such as commuters, customers, visitors, or people with disabilities, depending on the type of problem to be addressed.

Table 7 Importance of Transportation Modes

Groups	Walking	Cycling	Driving	Public Transit	Taxi	Air Travel
Adult commuters	2	1	3	2	1	1
Business travelers	2	0	3	2	3	3
College students	3	3	2	2	0	1
Tourists	3	2	3	2	2	3
Low-income people	3	2	2	3	2	0
Children	3	3	2	1	0	1
People with disabilities	3	2	1	3	2	2
Freight delivery	0	1	3	0	1	1

Different groups tend to rely more on certain modes. Rating from 3 (most important) to 0 (unimportant).

Basic accessibility analysis investigates people’s ability to reach goods and services considered *basic* or *essential*, such as medical care, basic shopping, education, employment, and a certain amount of social and recreational opportunities. This requires categorizing people according to attributes such as:

- Vehicle accessibility (degree that people have a motor vehicle available for their use).
- Physical and communication ability (consideration of various types of disabilities, including ambulatory, visual, auditory, inability to read, etc.).
- Income. In general, people in the lowest income quintile can be considered poor.
- Commuting. The degree to which people must travel regularly to school or work.
- Dependencies. The degree to which people care for children or dependent adults.

Case (2011) developed a model that evaluates non-drivers’ accessibility based on non-drivers trip generation rates. This technique can help identify the best neighborhoods to focus non-automobile transportation improvement efforts, including targeted walking, cycling and public transport improvements, more accessible land use development, and increased affordability.

A transportation deprivation index can be calculated which assigns points for factors that indicate people are transportation disadvantaged, as illustrated in the following table.

Table 8 Transport Deprivation Index Example

Factor	Rating System	Rating
Vehicle Accessibility	One point for each day of the week that the person normally cannot use an automobile.	
Physical ability	4 points for ambulatory or visual impairment; 3 for auditory impairment; 2 for communication impairment	
Poverty	3 if in the lowest quintile and 6 if in the lowest 10% income class.	
Commute Responsibility	One point for each day of the week that the person typically commutes outside their home.	
Dependencies	3 points for each child or disabled adult who normally depends on that person for physical caregiving.	
Totals	10-20 = moderate disadvantage. 20+ indicates severe disadvantage.	

This table describes a rating system for identifying people who are transportation disadvantaged. It can be adjusted to reflect specific planning needs and community values.

Mode

Different modes provide different types of accessibility and have different requirements, as summarized in Table 9. For example, walking and cycling provide more local access, while driving and public transit provide more regional access.

Table 9 Comparison of Transportation Modes (“Transport Diversity,” VTPI, 2006)

Mode	Speed	User Cost	User Requirements	Facilities
Walking	Low	Low	Physical ability	Walkways
Cycling	Medium	Low	Physical ability	Paths/roads
Public Transit	Medium	Medium	Minimal	Roads/Rails
Intercity Bus and Rail	High	Medium	Minimal	Roads/Rails
Commercial Air Service	Very High	High	Minimal	Airports
Taxi	High	High	Minimal	Roadways
Private Automobile	High	High	License	Roadways
Ridesharing	Moderate	Low	Minimal	Roadways
Carsharing	High	High	License	Roadways
Telecommunications	NA	Varies	Equipment	Equipment
Delivery Services	NA	Medium	Availability	Roadways

Different modes have different accessibility profiles.

The Access Across America program (<http://ao.umn.edu/research/america>) has quantified job accessibility by different modes (Owen and Levinson 2016; Owen, Murphy and Levinson 2018)

Recipe for Multi-modal Accessibility

Automobiles generally provide good accessibility, but many services and activities are difficult to reach by other modes. This is a problem because most communities contain a significant portion of people cannot or should not drive because they lack a driver's license, have a disability, cannot afford a car, are impaired by alcohol or drugs, or prefer to use alternative modes in order to save money, reduce stress, or exercise more. In addition, many communities want to minimize motor vehicle travel in order to reduce problems such as traffic congestion, parking facility costs, accidents and pollution emissions. It is therefore useful to identify ways to create multi-modal communities where residents do not need a personal car and can reduce their vehicle travel.

The following is a recipe for multi-modal accessibility:

- Compact, mixed urban development which creates *Transit-Oriented Development* (if located near a major transit station) or *Urban Villages* (if pedestrian oriented) where most commonly-used services (shops, restaurants, bank machine, schools, parks and recreation centers, public transit stops, etc.) can be reached within a 5-10 minute walk or bicycle ride of most homes and worksites.
- Good walking and cycling conditions, including sidewalks on most streets, safe crosswalks at all intersections and mid-block where necessary, bike lanes, bike parking, attractive paths, and traffic calming where needed to control motor vehicle traffic speeds.
- High quality public transit services, with good geographic coverage, frequency, comfort, safety and affordability.
- Universal design (ensuring that transportation systems and services accommodate people with diverse needs and abilities, including those with disabilities and special loads).
- Intermodal connections, such as good walking and cycling access, bicycle parking, local bus and taxi services at bus and train stations, ferry terminals and airports.
- Neighborhood carsharing and bikesharing services.
- Convenient and affordable taxi and ride-hailing services (e.g., Uber and Lyft).
- Telework options, such as on-line shopping, banking and municipal services.
- Efficient delivery services by mail, courier and local shops.
- Convenient user information concerning non-automobile transportation options.
- Social marketing which increases the status of non-automobile mode use.

An efficient multi-modal transportation system must integrate these facilities and services. For example, most public transit trips include walking and cycling links, so the feasibility of public transit travel depends on neighborhood walking conditions, and users need accurate information in order to use new travel options. Multi-modal planning involves identifying and filling system gaps.

Not everybody wants to live a multi-modal area – some people enjoy driving or value living in an isolate location – but because automobile travel is expensive and imposes significant external costs, everybody can benefit if any household that wants, including those with low incomes and special needs, can find suitable housing in area that offer high quality non-automobile accessibility.

Location

A particular location's accessibility can be evaluated based on distances and mobility options to common destinations. For example, some areas are automobile-oriented, located on major highways with abundant parking, poor pedestrian and transit access, and few nearby activities. Other areas are transit-oriented, with high quality transit service, comfortable stations, good walking conditions (since most transit trips include walking links), and nearby activities serving transit users (such as employment centers, retail, and public services, particularly those that serve people with lower incomes and disabilities).

Activity

Certain types of activities involve certain types of users, travel requirements, modes or locations which affect their accessibility. For example, worksites with many lower-income employees need walking, cycling, ridesharing and public transit access; industrial and construction activities need freight vehicle access; hospitals need access for emergency vehicles and numerous shift workers.

Summary

Accessibility evaluation should consider various perspectives, including different people, groups, modes, locations and activities. Accessibility evaluation often requires separate analysis for specific perspectives, and accessibility improvements may be targeted at specific groups, modes, locations or activities. For example, it is often appropriate to analyze the quality of accessibility to a particular destination or activity by various groups including motorists, non-drivers, people with disabilities and delivery vehicles.

Evaluating Accessibility

How accessibility is evaluated affects many planning decisions (ITF 2020; Levinson and King 2020). Current evaluation practices tend to measure *mobility* rather than *accessibility*, in part because mobility is easier to define and quantify (Levine 2020). Commonly used metrics include travel speeds, congestion delay and roadway level-of-service. Other modes and other accessibility factors are often overlooked or undervalued.

In recent years, new methods and tools have become available for evaluating accessibility (El-Geneidy and Levinson 2021). The following practices can lead to comprehensive accessibility evaluation:

- Accessibility should consider multiple users (drivers, non-drivers, people with disabilities), modes (walking, bicycling, public transit, automobile, etc.) and opportunities (education, jobs, shopping, healthcare, recreation, etc.).
- Accessibility should generally be measured door-to-door, taking into account the travel links from origins to vehicles and from vehicles to destinations.
- Travel distances should be based on actual network conditions, rather than as-the-crow-flies.
- Accessibility analysis should consider financial as well as time costs. This can be based on affordability indicators, such as households spending no more than 15% of their budget on transportation or no more than 45% of their budget on transportation and housing, which recognizes that a cheap house is not truly affordable if located in an inaccessible area where transportation will be expensive.
- The analysis should reflect the variability of travel time costs, with higher rates (dollars per hour) under uncomfortable travel conditions.

[*Measuring Accessibility: A Guide for Transportation and Land Use Practitioners*](#), by the State Smart Transportation Initiative (SSTI 2021) provides practical guidance concerning how to apply accessibility metrics in planning decisions, such as transportation project selection and land use suitability analysis. It provides extensive sample analyses to help illustrate the suggested methods and applications. It focuses on *cumulative opportunities* metrics, which show the number of activities (schools, jobs, parks, etc.) that can be reached within a given time periods, and describes tools that can provide this information.

The Brookings Institution's [*Moving to Access \(MTA\) Initiative*](#) aims to inform and promote access-oriented urban transportation policy, planning, investment, and services. The Initiative looks to move beyond theory and accelerate the adoption of these innovative efforts, exploring new tools, techniques, and performance measures across the developing and developed world. The program has published the following reports:

- [*A Common Narrative on Urban Accessibility: Overview*](#), by Jeffrey Gutman and Adie Tomer
- [*A Common Narrative on Urban Accessibility: A Transportation Perspective*](#), by Christo Venter
- [*A Common Narrative on Urban Accessibility: An Urban Planning Perspective*](#), by Gilles Duranton and Erick Guerra
- [*A Common Narrative on Urban Accessibility: A Fiscal / Finance Perspective*](#), by Shahid Yusuf

The [*Spatial Network Analysis for Multi-Modal Urban Transport Systems*](#) is an interactive decision tool designed to assist in examining the performance of a city region's current public transport network framed around the accessibility of the transport network and accessibility of place. It develops a Composite Index based on eight specific factors:

- [**Service intensity**](#) - What is the number of public transport services required to achieve an optimal level of accessibility across the network, noting that the resources may be limited?
- [**Closeness centrality**](#) - What is the ease of movement offered on public transport across the city and for each route?
- [**Degree centrality**](#) - What is the transfer intensity of the network? Is there a way of measuring whether transfer occurrence may be excessive or underdeveloped?
- [**Network coverage**](#) - What is the percentage of residents and employees within walking-distance to public transport services at a standard that allows for both planned and spontaneous trip making across most hours of the day, seven days a week?
- [**Contour catchments**](#) - What is the geographical range users can cover by public transport within a particular time frame, and how many destinations are located within this range?
- [**Betweenness centrality**](#) - How does the public transport network channel, concentrate and disperse travel opportunities generated by the interplay of land uses and the transport system?
- [**Resilience**](#) - Where on the network do these effects result in a potential mismatch between public transport supply and potential demand?
- [**Nodal connectivity**](#) - How well is each activity centre connected in order to attract stopovers, encourage land use intensification, and capitalise on such flows of people?

Eliasson (2020) provides guidance for measuring the user net benefits (consumer surplus) resulting from changes in accessibility, as indicated by changes in their travel activity, for example, the user benefit or cost provided by an improvement or decline in public transit service or vehicle travel speeds. These are often measured using the “rule of half.”

Cheng and Agrawal (2010) developed the *Time-Based Transit Service Area Tool* (TTSAT) which generates maps that show total, door-to-door transit trip travel time to destinations. Levinson (2013) measured the number of jobs that could be reached by automobiles within certain time periods for the 51 largest metropolitan areas in the United States for 2010, taking into account the geographic location of homes and jobs, roadway network connectivity and average traffic speeds. Rankings are determined by a weighted average of accessibility, giving a higher weight to closer jobs. Jobs reachable within ten minutes are weighted most heavily, and jobs are given decreasing weight as travel time increases up to 60 minutes. Based on this measure, the ten metro areas that provide the greatest average accessibility to jobs are Los Angeles, San Francisco, New York, Chicago, Minneapolis, San Jose, Washington, Dallas, Boston, and Houston.

Wu, et al. (2021) evaluated 30-minute access to jobs by four modes in 117 cities from 16 countries. They find that sprawled America cities provide modest automobile access and relatively poor transit and walking access; Australian and Canadian cities have lower automobile access, but better transit access; while Chinese and European cities tend to have the best overall

accessibility due to their combination of compact development and intensive transport network. This indicates that access requires optimal combinations of density and mobility.

Walkability deserves particular attention in accessibility analysis because it is important itself and supports other modes. For example, improved walking conditions increases the range of parking facilities that serve a destination, which improves automobile access, and most transit trips include walking links, so walkability improvements can improve transit accessibility. When measured based on distance, as is common in conventional transport planning, nonmotorized modes represent a tiny portion of total travel, suggesting that it is unimportant, but when measured based on time, as people generally experience travel, nonmotorized modes represent a significant portion of travel and so are recognized as relatively important, as illustrated in Figure 12. This is one facet of shifting from mobility-based to accessibility-based evaluation.

Figure 12 Portion of Travel By Various Units (DfT 2003)

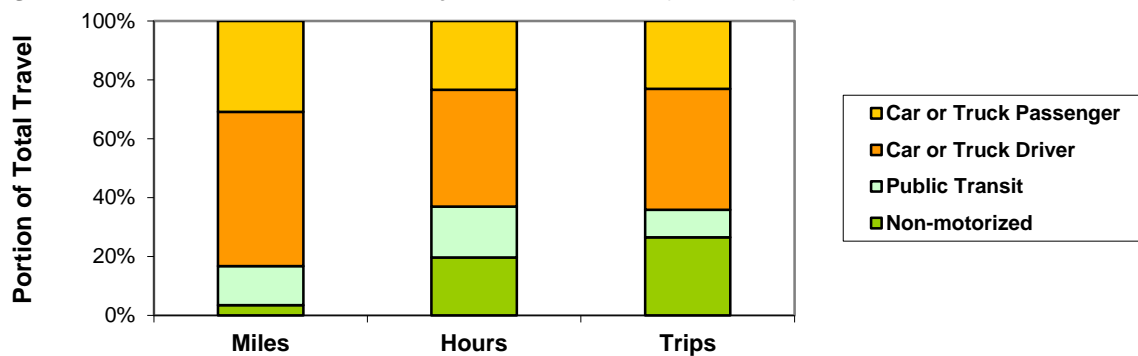

Non-motorized modes only represent 3-5% of travel distance, implying low importance, but 20-25% of travel time and trips, indicating greater importance.

Accessibility can be measured based on *generalized costs* (time and money) when evaluating the users perspective, and *total costs* (including indirect and non-market costs) when evaluating society's perspective. For example, commute accessibility can be evaluated by measuring the combined time and money that students and employees spend getting to school and work. The results can be evaluated to determine whether those costs are excessive, how commute accessibility varies for different demographic groups and geographic locations, and how various transportation system changes affect accessibility.

No single analysis method can evaluate all accessibility factors since different methods reflect different impacts, scales and perspectives. A particular planning decision may require use of multiple methods. For example, pedestrian accessibility evaluation requires local scale analysis that takes into account factors such as sidewalk and crosswalk quality, roadway traffic speed and volume, and inclines, plus surveys of users and potential users to identify perceived barriers and problems. Walking is particularly important for certain demographic groups (children, low income households, tourists) and in geographic locations (downtowns, to schools and parks), so walkability analysis is important for evaluating accessibility for these groups and areas.

To the degree that current planning practices favor mobility over accessibility, they result in sub-optimal investment in alternative modes (Martens 2006). More comprehensive evaluation

considers more impacts and options. Table 10 indicates reforms needed for more comprehensive and objective evaluation.

Table 10 Conventional Versus Comprehensive Evaluation (Litman 2007)

	Description	Conventional	Comprehensive
Generated Traffic & Induced Travel	Whether planning accounts for generated traffic and induced travel impacts.	Ignore or applies limited analysis	Comprehensive analysis
Downstream Congestion	Additional congestion on surface streets that results from increased highway capacity.	Generally ignored	Considered
Vehicle Costs	Which vehicle costs are considered.	Operating costs only	Ownership and operating costs
Parking Costs	Parking costs	Only user fees	All parking costs
Construction Impacts	Whether construction period congestion delays are considered.	Ignores	Includes
Nonmotorized Travel Impacts	Whether walking and cycling convenience, safety, comfort and cost are considered.	Limited analysis	Comprehensive analysis
Transit Service Quality	Whether transit comfort and convenience are fully valued.	Undervalues transit quality	Values all transit quality factors.
Transportation Diversity	Whether all the benefits of improving mobility options (particularly for non-drivers) are considered.	Limited analysis	Comprehensive analysis
Environmental Impacts	Range and detail of environmental impacts considered in analysis.	Limited analysis	Comprehensive analysis
Community Livability	Impacts on community livability, including neighborhood walkability and affordability.	Limited analysis	Comprehensive analysis
Equity Impacts	Whether impacts on community equity objectives are considered.	Limited analysis	Comprehensive analysis
Land Use Impacts	Whether impacts on land use development objectives (e.g., smart growth) are considered.	Limited analysis	Comprehensive analysis
Safety and Health	Consideration of safety and health impacts.	Crash rates	All health impacts

Conventional evaluation tends to overlook many of the costs of increased automobile traffic and many of the benefits of alternative modes and mobility management.

Newer models incorporate multi-modal LOS factors to better evaluate walking, cycling, public transit and parking conditions (FDOT 2007). Table 11 describes various ways of improving current models to make their analysis more accurate and comprehensive.

Table 11 Transport Model Improvements (“Model Improvements,” VTPI 2006)

Factor	Problems With Current Models	Appropriate Corrections
Accessibility	Most transportation models primarily evaluate <i>mobility</i> (movement), rather than <i>accessibility</i> (people’s ability to obtain desired goods and activities)	Develop multi-modal models which indicate the quality of nonmotorized and transit travel, and integrated transportation/land use models which indicate accessibility
Modes considered	Most current models only consider automobile and public transit	Expand models to evaluate other modes, including walking and cycling
Travel data	Travel surveys often undercount short trips, non-motorized travel, off-peak travel, etc.	Improve travel surveys to provide more comprehensive information on travel activity
Consumer Impacts	Most apply relatively crude analysis of consumer impacts. For example, they assume that shifts from driving to slower modes increase costs.	Improve consumer surplus analysis in transport evaluation. For example, recognize that shift to slower modes in response to positive incentives provide net user benefits
Travel time	Most models apply the same travel time value to all travel, regardless of conditions	Vary travel time cost values to reflect travel conditions, such as discomfort and delay
Nonmotorized travel	Most travel models fail to account for nonmotorized travel impacts, and so undervalue nonmotorized improvements	Modify existing models or develop special models for evaluating nonmotorized transportation improvements
Impacts Considered	Current models only measure a few impacts (travel time and vehicle operating costs)	More comprehensive impact analysis, including crashes, emissions, pedestrian delay, etc.
Transit elasticities	Most models use short- and medium-run transit elasticity values which understate long-term impacts	Use more appropriate values for evaluating long-term impacts of transit fares and service quality
Self-fulfilling prophecies	Traffic projections assume that demand is inflexible, justifying roadway expansions which induce more traffic.	Report travel demand as a variable (“traffic will grow 20% if current policies continue, 10% with \$1 daily fees, and 0% with \$2 daily fee”).
Generated traffic and induced travel	Traffic models fail to account for generate traffic (additional peak-period traffic) induced travel (net increases in total vehicle travel) caused by roadway expansions	Incorporate various types of feedback into the traffic model. Develop more comprehensive economic analysis models which account for the economic impacts of induced travel
Construction impacts	Economic models often fail to account for the construction periods congestion costs	Take congestion delays into account when evaluating roadway projects
Transport diversity value	Often underestimate non-auto travel demands and benefits of improved travel options.	Recognize the various benefits that result from improving accessibility options
Land use impacts	Models often fail to indicate how transport decisions will affect land use development, and therefore accessibility and strategic planning objectives	Develop integrated transportation and land use planning models which predict how transport decisions affect land use patterns and how land use decisions affect accessibility

This table summarizes ways of improving computer models used in transportation planning.

Accessibility-based evaluation models are available that take into account various modes and land use factors (2018; Kaufman, et al. 2014; ITF 2020; Levinson and King 2020). Similarly, Ciommo (2018) developed an *inaccessibility index* which indicates the number of desirable activities (such as jobs, healthcare and shopping) that a particular demographic group cannot reach. These use geographic information systems (GIS) to measure the travel distance between various activities, such as average distances between homes and services, or the number of jobs within a half-hour travel distance of residents. Some also account for transport factors, such as area walkability and transit service frequency. However, even these models generally overlook some factors affecting overall accessibility, such as transit service comfort, user information availability, and perceived pedestrian security. Additional analysis may therefore be required to account for these factors.

Special analysis can evaluate the quality of accessibility for specific groups and locations. For example, evaluation of accessibility by elementary students should include analysis of the convenience, comfort, safety, affordability and speed of walking, cycling, automobile and school bus service. Similarly, evaluating accessibility of a commercial district should include analysis of the quality of walking, cycling, automobile, public transit, taxi service and parking conditions.

Martens (2006) argues that current transport evaluation practices are economically inefficient and regressive because they exaggerate the benefits of automobile-oriented improvements and undervalue improvements to alternative modes, which skews planning decisions to favor the mobility-rich (people who currently drive high mileage) to the detriment of the mobility-poor (people who currently drive low mileage and rely on alternative modes). To correct these problems he recommends the following changes to transportation modeling and economic evaluation techniques:

- Evaluate transport improvements primarily in terms of *accessibility* rather than *mobility*. For example, improvements should be rated based on the number of public services and jobs accessible to people, taking into account their ability (i.e., ability to walk and drive), travel time and financial budgets, not simply travel time savings to vehicle travelers.
- Assign value to accessibility gains inversely related to people's current levels of accessibility, to reflect the principle of diminishing marginal benefits. Accessibility gains for the mobility-poor should be valued higher than the same increase in accessibility by the mobility-rich.

Overall accessibility can be evaluated with regard to time and money budgets. People typically devote 60-90 minutes a day and 15-20% of their household budgets to transport, and are willing to spend 5-10 minutes traveling for errands such as shopping and taking children to school. If such services are sufficiently accessible for pedestrians, some people will choose to walk. If not, most people who can will drive. Similarly, thirty minutes and two to four dollars in expenses represents the maximum one-way commute budget. Transport systems that force people to exceed these time and money budgets tend to create a burden, particularly on lower-income households.

Rendall, et al. (2011) quantify *Active Mode Accessibility (AMA)*, defined as the proportion of activities that can be reached by active modes (walking, cycling, and public transport) alone, given the population demographics of the study area. AMA is characterized by the underlying

geographic form of an urban area and its transport networks. They describe methods for calculating the AMA and apply it to case studies.

Planners can therefore evaluate:

- The quality of accessibility by different modes and in specific areas.
- The quality of accessibility by various groups and how they compare, with particular attention to the relative quality of accessibility by disadvantaged groups.
- Possible strategies for improving accessibility, including increased user comfort, convenience and affordability, not just travel speed.
- Possible strategies for improving alternative modes and reducing automobile travel.
- Which groups bear excessive time or financial costs for basic mobility.

Automobiles and Cities

Automobiles are complex systems that provide mobility. By increasing travel speeds, and therefore the distance that can be traveled in a given time period, automobiles increase the goods, services and activities accessible from a particular location.

Cities are complex systems that provide accessibility. By reducing the distances between destinations and improving transport options (better walking conditions and public transit services) cities also increase the goods, services and activities accessible from a particular location.

These two methods of improving accessibility often conflict. Transportation planning decisions intended to enhance automobile travel (wider roads, increased traffic speeds, larger parking facilities, highway-oriented development) often degrade urban conditions and travel services.

Conventional transport planning recognizes the benefits of mobility but often overlooks the benefits of urban accessibility. For much of the last century transportation planning decisions have favored mobility over urban accessibility. A more complex framework for evaluating accessibility allows decision-makers to better understand how specific policies and planning decisions will affect overall accessibility.

Optimal Accessibility and Mobility

It is interesting to consider the levels of accessibility and mobility that are overall optimal, and how this is affected by the evaluation methods used. Transportation planning often assumes that any increase in mobility is beneficial and desirable, but there are, of course, various economic, social and environmental costs.

According to economic theory, the optimal levels of accessibility and mobility are the amount that consumers would choose in an optimal market, in which they have an appropriate range of travel and location options, and prices reflect costs (users bear directly all costs resulting from their transport activities). Beyond this optimum, increased mobility is economically excessive and harmful to society. Litman (2007) examines various reforms that would make transport and land use markets more efficient. These include, for example, efficient road and parking pricing, neutral planning and funding, and accessibility-based land use planning practices. The study concluded that in a more optimal market, consumers would choose to drive significantly less, rely more on alternative modes, and be better off overall as a result.

For example, charging motorists directly when they use parking facilities typically reduces vehicle travel by 10-30%, and distance-based vehicle insurance and registration fees reduce driving about 10%. Least-cost planning, which funds alternative modes and mobility management programs when they are more cost effective than facility expansion often reduces driving by 10-30%. Land use policy reforms, which correct existing market distortions that favor lower-density development patterns also tend to reduce automobile travel and encourage use of alternative modes.

In more optimal markets people would probably achieve about the same amount of accessibility, but rely more on non-automobile strategies, including more walking, cycling, ridesharing, public transit and telecommunications, and accessible locations. For example, these reforms would give commuters more incentive to use alternative modes, families more incentive to choose homes within walking distance of schools, and businesses more incentive to choose locations served by quality public transit. More comprehensive analysis, which takes into account more transport impacts and options, tends to justify more support for alternative modes, constraints on driving, and accessible land use patterns. For example, considering costs such as parking subsidies and pollution emissions tends to justify more investments in alternative modes, and considering mobility management strategies and land use accessibility improvements tends to justify shifting resources away from road and parking construction.

Although many communities are implementing some of these reforms, no communities have implemented all market based reforms. This may justify the implementation of other incentives, such as subsidies for alternative modes and restrictions on vehicle travel, on second-best grounds, and to help achieve strategic planning objectives, such as increasing land use accessibility and reducing sprawl. It is, however, difficult to determine to what degree such interventions are justified.

Evaluating Automobile Dependency

Automobile dependency (also called *automobile orientation*) refers to transportation systems and land use patterns that favor automobile access and provide relatively inferior alternatives (“Automobile Dependency,” VTPI, 2006). In this case, *automobile* includes cars, vans, light trucks, SUVs and motorcycles. Its opposite is a *balanced* or *multi-modal* transportation system, meaning that consumers have relatively diverse accessibility options, although automobile travel may still be a major or even dominant mode.

Automobile dependency determines how accessibility differs between drivers and non-drivers, and therefore non-drivers’ relative disadvantage. This affects both equity (since one group is relatively worse off than others) and efficiency (since non-drivers are unable to access education and jobs). This indicates that automobile dependency is both unfair and inefficient, or described more positively, increasing transport system diversity provides both efficiency and equity benefits (Litman, 2001). Automobile dependency can be evaluated from various scales and perspectives. For example, a walkable, mixed-use neighborhood may be multi-modal at a local scale but automobile dependent at a regional scale due to poor transit service. Automobile dependency can be evaluated based on:

- Per capita annual vehicle travel.
- Mode split (portion of total travel by various modes). In general, automobile mode split over 90% indicates a high degree of automobile dependency, and less than 75% indicates a fairly multi-modal community, where non-drivers are not significantly disadvantaged.
- Mode split by discretionary travelers (use of alternative modes by people who could drive), which indicates whether alternative modes provide high service quality.
- Land use accessibility (the amount of mobility needed to reach a typical set of destinations).
- The relative difference in generalized travel costs (combined financial costs and monetized travel time) between drivers and non-drivers to reach a typical set of destinations.
- Quantity and quality of alternative modes available. This can be quantified using multi-modal level-of-service rating (FDOT 2007).
- Specific indicators, such as the portion of children who walk or bicycle to school.

Although inadequate mobility can constrain people’s ability to participate in desired activities, the increase in people’s ability to travel does not necessarily result in more participation. Just because people can access activities does not necessarily mean that they take advantage of the opportunities. For example, Farber and Páez (2009) found that automobile reliance increases social activity by people who are less mobile (home-makers and unemployed people), but decreases social activity in more mobile subgroups (full time workers). Automobile reliance is found to have a strong negative impact on the probability of visiting friends and participating in out-of-home sports and cultural events, but a positive effect on in-home and potentially asocial amusements such as television viewing.

Some people assume that automobile dependency inevitably increases with wealth, but there is evidence that many affluent people prefer transport diversity and will use alternative modes if of suitable quality. For example, many prestigious residential areas are walkable, mixed-use

neighborhoods; many successful professionals prefer alternative commute modes; and many economically successful cities have declining automobile mode split (“Success Stories,” VTPI 2006). Although per capita vehicle ownership and use tend to rise as incomes increase from poverty to middle levels, the ultimate degree of automobile dependency is determined by policy and planning decisions. If decision-makers consider multi-modalism desirable they will support diversity. This indicates, as the previous section concluded, that a multi-modal transport system is overall optimal.

Strategies for Improving Accessibility

This section describes various ways to improve accessibility. For more information see VTPI (2006)

Table 12 uses the list of factors that affect accessibility from Table 5 to help identify possible ways of improving accessibility. Current transport planning and evaluation practices tend to focus on certain types of accessibility improvements, particularly those that increase motor vehicle travel speeds and parking convenience, which limits the scope of potential solutions to transport problems.

Table 12 Potential Accessibility Improvement Strategies (VTPI 2006)

Factors	Improvement Strategies
Access and Mobility Demand	Use research to better understand people’s accessibility and mobility needs, preferences and abilities, and use social marketing strategies to develop better options that respond to these demand, and to encourage consumers to choose more efficient and equitable options.
Basic Access and Mobility	Prioritize transportation improvements and activities to favor access to goods, services and activities considered most important to society.
Mobility	Improve traffic speed and capacity, such as improving and expanding roadways.
Transportation Options	Improve the convenience, comfort, safety, reliability, affordability and speed of transport options, including walking, cycling, automobile, rideshare, taxi, carshare and public transit.
User Information	Improve the quantity and quality of user information regarding travel and location options, including signs, maps, brochures, websites and telephone services. Special attention can be given to providing convenient information on alternative modes and efficient locations.
Integration	Improve connections between different modes and destinations, such as more integrated information, fares, walkability, baggage transfers, automobile and bicycle parking.
Affordability	Improve affordable modes (walking, cycling, ridesharing, public transit, taxi and telework), and affordable housing in accessible locations.
Mobility Substitutes	Improve the quantity and quality of telecommunications and delivery services that substitute for physical travel.
Land Use Factors	Improve land use accessibility by increasing density and mix. Create walkable, bikeable and transit-oriented urban villages that contain appropriate housing, jobs and services.
Transport Network Connectivity	Improve road and path connectivity to allow more direct travel between destinations, including special shortcuts for non-motorized travel where appropriate.
Roadway Design and Management	Improve roadways to increase traffic flow (for example, by reducing the number of driveways), to favor higher occupant vehicles, and to improve walking and cycling conditions.
Prioritization	Use mobility and parking management strategies to favor higher value trips and more resource-efficient vehicles, and to encourage more accessible land use development.
Improve Payment Systems	Better road and parking pricing methods reduce transaction costs and increase the feasibility of implementing pricing reforms to increase overall transportation system efficiency.
Inaccessibility	To achieve community goals such as ecological preservation, limit mobility and accessibility.

This table indicates various ways to improve accessibility. Current transport planning practices tend to focus on just a few of these strategies, which limits the scope of solutions considered.

Various terms are used for planning to improve accessibility, including Smart Growth, location efficient development, multi-modal planning, urban villages, and most recently, 15-minute neighborhoods (Duany and Steuteville 2021). All of these terms refer to planning that favors compact, mixed, multimodal, and walkable urban development where most commonly-used services are easily reached without driving, so it is easy to live car-free. Surveys indicate that many residents would prefer to drive less and rely more on alternative modes, and choose more accessible locations, provided those options are suitably convenient, comfortable, safe, affordable and prestigious (NAR 2017).

Prioritization can improve accessibility for higher value trips and more resource-efficient modes, for example, by favoring vanpools, transit and freight vehicles over lower value vehicles on congested roadways. These strategies tend to be most effective if implemented as part of an integrated program that improves travel options and land use accessibility. This is particularly important in urban areas where it is costly to expand facilities and where increased traffic imposes significant external costs.

Non-motorized modes (walking, cycling and their variants such as wheelchairs and scooters) are particularly important because they provide mobility and support other modes. For example, most transit trips include walking links, so improving walking conditions can improve transit accessibility. Nonmotorized improvements include improved sidewalks, crosswalks, paths, bikelanes, traffic calming, safety education, law enforcement and encouragement programs, bicycle parking, improved security and *universal design* (facilities designed to accommodate all users, including people who rely on mobility aids such as wheelchairs and walkers. More compact and mixed land use, narrow roads, short blocks and pedestrian shortcuts tend to improve walkability.

Public transit improvements can increase mobility and accessibility in several ways. They improve mobility for non-drivers and increase transport affordability, and they can reduce traffic and parking congestion by attracting discretionary travelers (people who would otherwise drive). In addition, high quality transit often provides a catalyst for more accessible, walkable land use development patterns, which further increases mobility options and improves accessibility (Palmateer, Owen and Levinson 2016).

To determine the most effective accessibility improvements in a particular situation it is helpful to identify the major accessibility constraints that apply and develop appropriate responses, as illustrated in Table 13.

Table 13 Accessibility Constraints and Solutions

User Group	Major Accessibility Constraints	Improvement Strategy
Urban commuters	Traffic and parking congestion.	Expand roads and parking facilities, improve alternative modes (particularly grade-separated public transit), congestion pricing.
Low-income commuters	Fuel costs, parking costs and vehicle unreliability.	Subsidize fuel and parking. Improve affordable transport options (walking, cycling, ridesharing, public transit). Increase housing affordability in accessible locations.
Non-drivers	Inadequate alternative modes and poor connections between these modes (such as difficulty taking a bicycle on a bus).	Improve walking and cycling conditions, rideshare and public transit services, user information, connections among modes.
Children/teenagers	Poor walking and cycling conditions, inadequate public transit services.	Improve walking and cycling conditions (particularly safety), improve public transit, provide suitable user information.
Visitors and mode shifters	Inconvenient user information.	Improve user information.
Mode shifters	Stigma (walking, cycling and public transit are considered inferior)	Marketing to increase the status of alternative modes.
People with disabilities	Unsuitable walking facilities, unsuited vehicles (automobiles, public transit and taxi), inadequate user information.	Improve pedestrian facilities and vehicles to accommodate mobility aides, improve user information.
People with physical disabilities	Constraints described above, plus financial constraints.	Low transit and taxi fares, targeted discounts for low-income disabled people, special telephone and Internet services.
Shippers	Congestion delays, inconvenient parking (particularly for urban deliveries), high fuel costs.	Congestion pricing (so higher value trips can outbid lower value trips on congested roads), better delivery vehicle parking options, development of more fuel efficient shipping services (such as rail transport).

This table indicates the major accessibility constraints facing specific types of people or situations, and appropriate responses. This type of analysis should be adjusted to reflect specific situations.

Accessibility-based planning tends to expand the range of impacts and options considered. Conventional planning tends to favor roads and parking facility improvements, but accessibility-based planning considers other factors, including the tendency of wider roads and larger parking lots to reduce accessibility by other modes (particularly walking and public transit), and the potential to address such problems by improving travel options and increasing land use accessibility.

Examples and Tools

Various methods and tools can be used to measure accessibility. Note that they vary widely in scope, including modes, impacts and geographic scale.

20-Minute Neighborhoods (<http://tinyurl.com/n7hg87k>)

The City of Portland (2012) uses GIS mapping to evaluate the number of commonly-used services that can be accessed within a 20-minute walk of residences, taking into account sidewalk conditions, natural and roadway barriers, street connectivity and topography.

Access to Destinations (<http://access.umn.edu>)

Access to Destinations by the Accessibility Observatory (<http://ao.umn.edu>) is a research program by the University of Minnesota's Center for Transportation Studies which is developing tools and data sets to quantify overall accessibility, taking into account multiple modes (walking, cycling, public transit and automobile) and land use development patterns. It was initially applied to the Twin Cities region. It found:

- More centralized population and employment tends to increase overall accessibility.
- The number of zones that provide access to a million jobs within a 20 minute commute increased from one 1995 to twenty by 2005.
- During this time the region's pedestrian accessibility decreased but new bike networks increased cycling accessibility. A third of walking trips exceeded a mile, calling into question the long-standing assumption that walking trips are limited to a quarter-mile.
- The region's first light-rail line had a positive effect on many accessibility measures.
- *Access Across America* (<http://ao.umn.edu/research/america>) measures accessibility to jobs via various transport modes in major metropolitan areas across the United States.

Access to Opportunities Primer (<https://escholarship.org/uc/item/98g9d5p4>)

The *Access to Opportunities Primer* (Bhusal, Blumenberg and Brozen 2021) is intended to help policymakers, public officials and their staff, and advocates understand access to opportunity: its importance and its determinants, and how it relates to issues such as housing policy and economic development. It discusses how accessibility varies by user group, mode, opportunity, and geographic location. It examines how the legacy of racist policies like redlining and discrimination contribute to disparities in access, and how to addressing these disparities.

Access to Everyday Destinations (<http://bit.ly/2qFfdcw>)

The study, *What Makes Housing Accessible to Everyday Destinations in Southern California?* (Kane, Kim and Hipp 2017) analyzed five million Southern California homes' access to 31 destination types including stores, banks, schools, hospitals and open space. They find greater accessibility in older neighborhoods. The authors recommend that, to reduce traffic problems, new developments should be located to maximize accessibility to important destinations.

Accessibility Evaluation Tools (<http://bit.ly/2tYwxtP>)

The report, *Linking People and Places: New Ways of Understanding Spatial Access in Cities* (ITF 2017), found that planners are developing increasingly sophisticated tools for measuring urban accessibility for various demographic groups, trip purposes, modes and times and costs (time and money). Despite faster and less congested transport networks, residents in more affluent cities often have less accessibility due to more sprawled development patterns.

Accessibility-Based Regional Planning ([Proffitt, et al. 2019](#))

The study, [Accessibility Planning in American Metropolitan Areas: Are We There Yet?](#) investigated the gaps between accessibility-based planning theory and practice. It surveyed the contents of a nationally representative sample of 42 US regional transportation plans (RTPs) and statistically analyzed the characteristics of metropolitan areas that are most likely to apply accessibility concepts. It found that most RTPs include accessibility-related goals, but few define the term or use accessibility-oriented performance measures. This leaves vehicle speed as the primary criterion for success in most plans. MPOs serving large and wealthier regions are the most likely to apply accessibility-based planning. The authors speculate that this reflects their greater planning capacity. The article recommends planning reforms to speed the adoption of the accessibility paradigm in RTPs.

Active Transport (Walking and Cycling) Planning for Equity

(www.fhwa.dot.gov/environment/bicycle_pedestrian/resources/equity_paper)

The report *Pursuing Equity in Pedestrian and Bicycle Planning* (Sandt, Combs and Cohn 2016) examines the travel demands of traditionally underserved populations (low income, minority, older adults, and people with limited language proficiency and disabilities), and identifies practical ways to better serving those groups. It finds:

- Many children, older adults, and people with disabilities are unable to drive and so tend to rely on nonmotorized modes, but often travel on roads lacking safe pedestrian and bicycle facilities, and often practice unsafe cycling (e.g., lacking lights and helmets).
- Many underserved population groups live where public transit services are limited.
- Many traditionally underserved populations suffer from problems associated with physical inactivity, could be addressed through improved walking and cycling conditions.
- Women and minorities feel less safe bicycling than non-minority males, and many agreed that, given better cycling facilities, they would be more likely to bicycle for transportation.
- Residents with limited travel options travel less overall, make fewer trips for shopping and socializing; have a harder time gaining employment; are less likely to access healthy foods, health care, and educational resources; and are more likely to experience social isolation.

The report concludes that pedestrian and bicycle improvements can help reduce inequities and identifies specific ways to make pedestrian and bicycle planning more responsive to underserved residents, including new evaluation tools and more participatory planning. It includes examples and case studies.

Evaluating Automobile Dependency (www.jtlu.org/index.php/jtlu/article/view/583)

The report, “How Does the Spatial Context Shape Conditions for Car Dependency?” (Wiersma, Bertolini and Straatemeier 2017) found that in the Netherlands most households can walk or bicycle to daily amenities but cars provide the greatest job accessibility.

Exploring New Measures of Travel Behavior (<https://brook.gs/3LJUbr>)

This report uses digital tracking technologies and mapping systems to measure local travel patterns, including by trip purpose and distance, in six U.S. metro areas. It found that average trip distances often exceeds 7 miles, reflecting automobile dependency.

Inaccessibility Index for Social Equity Analysis (<https://bit.ly/2QJoj4Q>)

Ciommo (2018) developed an *inaccessibility index* which indicates the number of desirable activities (such as jobs, healthcare and shopping) that a particular demographic group cannot reach. The results are used to evaluate the social equity impacts of strategic planning decisions in Barcelona, Spain, such as city center vehicle restrictions, parking policy changes, public transit service improvements, and park-and-ride services. The results indicate that the inaccessibility index analysis provides a practical way to consider equity impacts in planning decisions.

Figure 14 **Commute Duration** ([Mineta Institute Commute Duration Mapping System](#))

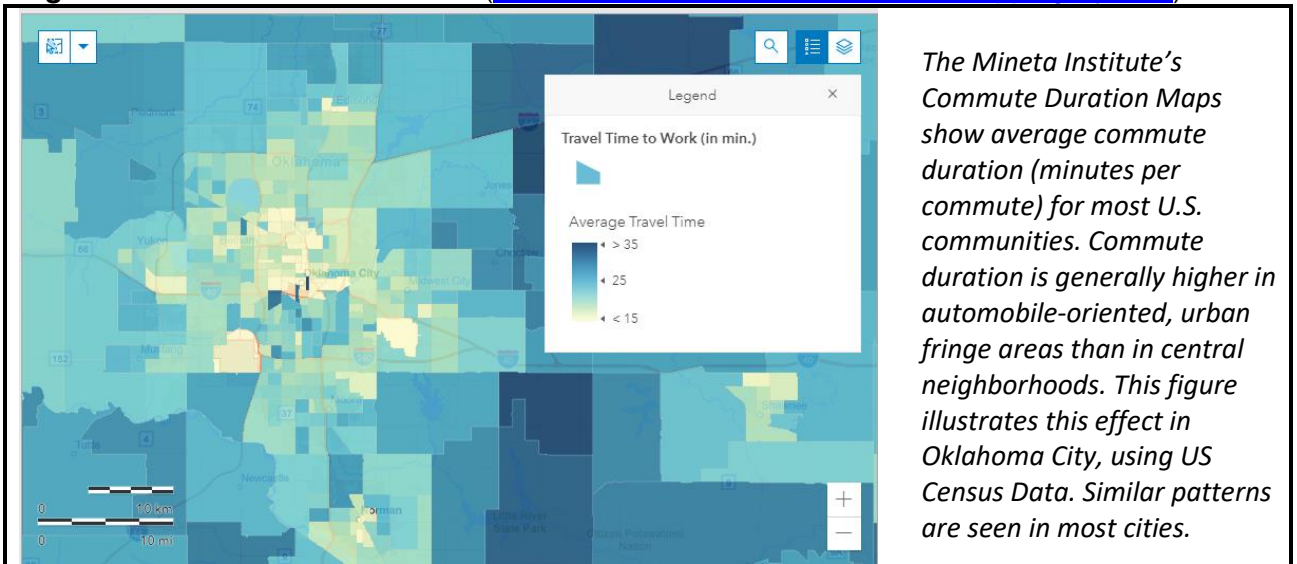

London WebCAT (<https://bit.ly/2IsXd5K>)

WebCAT is a Web-based Connectivity Assessment Toolkit which allows users to map the areas and destinations that can be reached by public transit within a given time period, taking into account walking and transit travel times. Inayathusein and Cooper (2018) describe how this information is used for planning analysis, and possible ways it could be improved.

Figure 13 **London's WebCAT Mapping System** (<https://bit.ly/2j3u5Oq>)

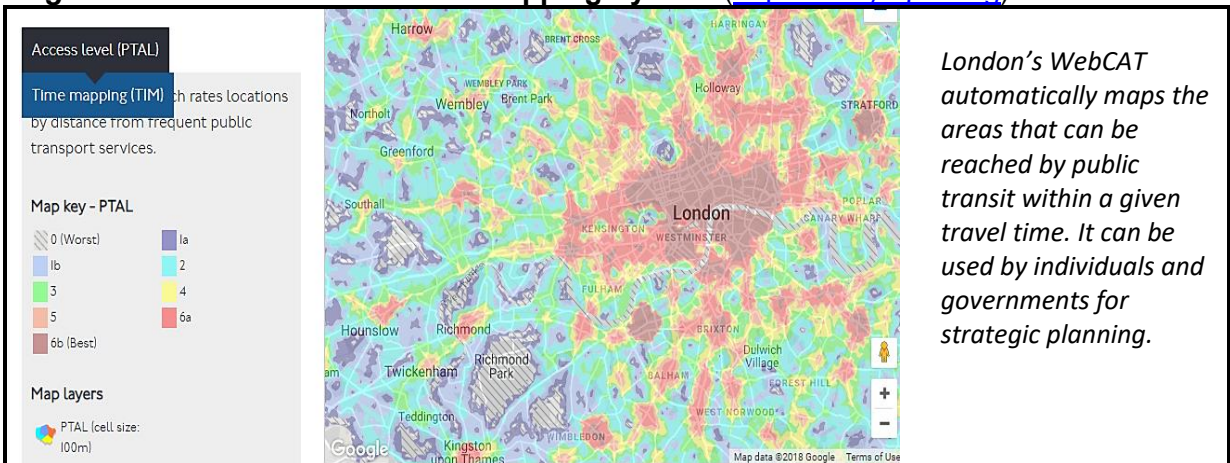

Measuring Transit Accessibility in Ahmedabad

Shah and Adhvaryu (2016) developed a GIS mapping tool in Ahmedabad, India that shows public transport accessibility levels (PTAL) taking into account average walk speeds, distances to transit stops and peak-hour transit service frequencies. This tool can be used to help planning and investment decisions, parking policies, and developing transit-oriented zoning regulations, and it demonstrates that such tools can function in developing as well as developed countries.

Moving To Access Initiative (www.brookings.edu/research/reports2/2016/05/moving-to-access)

The Brookings Institution's *Moving to Access (MTA) Initiative* aims to inform and promote more socially focused, access-based transportation policy, planning and investment. This initiative looks to move beyond theory and accelerate the adoption of these innovative efforts, exploring new tools, techniques, and performance measures across the developing and developed world.

Measuring Community Remoteness and Accessibility (<http://bit.ly/2tDGIEF>)

The report, *Measuring Remoteness and Accessibility - A Set of Indices for Canadian Communities* (Alasia, et al. 2017) uses gravity model principles, which account for both the proximity to population or service agglomerations, to measure a community's accessibility and remoteness. It measures proximity using travel costs, and the population size of nearby centres (towns and cities) to measure service availability.

Opportunity Score (<https://labs.redfin.com/opportunity-score>)

This program ranks locations in 350 U.S. cities based on the number of jobs that can be accessed within a 30-minute walk or transit ride.

Public Transit Accessibility Levels (<http://bit.ly/2raLR8b>)

Public Transit Accessibility Levels (PTALS) is a standardized method for measuring a location's public transport network accessibility, taking into service availability and walk access time. It does not consider service speed or utility, crowding or ease of interchange. Each area is graded between 0 (very poor access) and 6b (excellent access). It is used in Britain.

Revision (http://revision.lewis.ucla.edu/?mc_cid=6d7654de44&mc_eid=b8e4b2304e)

This regional mapping, analysis and visualization program integrates a range of public and private data and performance indicators for sustainable community evaluation.

Smart Location Mapping (www.epa.gov/smartgrowth/smart-location-mapping)

This program provides interactive maps and data for measuring location efficiency, including the effects of the built environment on per capita vehicle travel, and methods for measuring access to jobs and workers by public transportation.

Speed Versus Density (<http://tinyurl.com/cpdmmf6>)

The study, "Does Accessibility Require Density or Speed?" (Levine, et al. 2012) evaluates accessibility based on the people and activities that can be reached in a given time. The results indicate that denser regions are more accessible overall because their slower travel speeds are more than offset by their greater proximity between origins and destinations.

Cube Access (<https://communities.bentley.com/products/mobility-simulation-analytics>)

CityLab's *Cube Access* is an integrated Geographic Information Systems (GIS) software program that can measure the time and financial costs of accessing various services and activities (healthcare, shops, schools, jobs, parks, etc.) by various travel modes in a particular area.

Toolbox for Regional Policy Analysis (www.fhwa.dot.gov/planning/toolbox/index.htm)

This Federal Highway Administration website describes methods for evaluating regional economic, social and environmental impacts of various transportation and land use policies.

Transport Planning with Accessibility Indices in the Netherlands (<https://bit.ly/2PQ8pUX>)

Geurs (2018) describes methods used to evaluate accessibility in the Netherlands. Dutch academics and practitioners use integrated accessibility measurements that consider user needs, abilities, mobility and land use factors for investment planning and social equity/justice analysis. They find various trade-offs between theoretical and practical strengths; more comprehensive and accurate indices tend to be data intensive and difficult to understand.

Transit Versus Transit-oriented Development (<http://hdl.handle.net/11299/181535>)

The Synergistic Effects of Transit Oriented Development and Transit Hubs on Accessibility in the San Francisco Bay Area (Palmateer, Owen and Levinson 2016) evaluated how public transit service improvements and transit-oriented development affect regional transit accessibility. It found that station-area development increases accessibility more than increased transit service.

Transportation for Everyone Rating System (www.vtpi.org/choice)

Table 14 summarizes the *Transportation for Everyone* rating system, which evaluates local mobility and accessibility options, and helps identify gaps and improvement options. It recognizes that many factors can affect accessibility.

Table 14 Transportation for Everyone Rating (Litman 2017)

Accessibility Factors	Rating (1-10)
1. All-weather (paved) roads, and reliable motor vehicle fuel supplies.	
2. Compact, mixed urban development, which creates <i>Transit-Oriented Development</i> (if located around transit stations) or <i>Urban Villages</i> (if pedestrian oriented), where most common services (shops, restaurants, schools, parks, transit stops, etc.) can be reached within a 5-10 minute walk or bicycle ride of most homes and worksites.	
3. Good walking and cycling conditions, including adequate sidewalks, crosswalks, paths, bike lanes, bike parking, and vehicle traffic speed control.	
4. High quality public transit services, with good coverage, frequency, comfort, safety and affordability for both local and interregional (between city) services.	
5. Good connectivity, including dense walking and road networks, and intermodal connections such as walking and cycling access, and taxi services at transit stations.	
6. Convenient and affordable carsharing and bikesharing, taxi and ride-hailing services.	
7. Universal design (the ability of transportation systems to accommodate people with diverse needs and abilities, including those with disabilities and heavy loads).	
8. Good telework options, such as on-line shopping, banking and municipal services, and efficient delivery services ((mail, courier and local shops).	
9. Convenient user information concerning transportation options.	
10. Social marketing that promotes non-automobile modes and enhances their status.	

Each factor can be rated from 0 (worst) to 10 (best).

Velocity Score: Urban Accessibility and Equity (www.citychrone.org)

The *Vilocity Score* evaluates urban transportation systems performance and equity based on three factors: city cohesion (the portion of a population that can be reached within a given time period), average velocity (average travel time from one location to another) and city sociality (average number of people a person using transportation options might meet on a given trip) (Biazzo, Monechi and Loreto 2019). These factors are calculated for specific cities and illustrated using isochronic maps. Considering all factors, Berlin ranked highest, followed by Paris and then Copenhagen, and Mexico City ranked lowest of 32 major cities. However, rankings changed when cities are evaluated based on specific factors.

Accessibility in Practice (www.ssti.us/2017/07/accessibility-in-practice)

This *State Smart Transportation Initiative* report offers practical guidance on implementing accessibility-based planning. It outlines concepts, data needs and availability, analysis tools, and other considerations in measuring accessibility, and describes examples of such analyses.

Tools of the Trade (www.tandfonline.com/doi/full/10.1080/01944363.2021.1899036)

The report, *Tools of the Trade*, describes how accessibility metrics are currently applied and the potential for emerging tools to better measure the many dimensions of access suitable for planners, public officials and the general public. Most existing tools focus on a single mode and for limited geographic scales, but use of multimodal and multifaceted metrics is growing. There are unmet needs for tools that measure the accessibility of individual travelers, taking into account how access can vary between different types of travelers.

Urban Accessibility Analysis Framework (www.itf-oecd.org/benchmarking-accessibility-cities)

The International Transport Forum's report, *Benchmarking Accessibility in Cities: Measuring the Impact of Proximity and Transport Performance*, describes a framework for evaluating urban accessibility based on the number of destinations (schools, hospitals, food shops, restaurants, people, recreational opportunities and green spaces) that can be reached on foot, by bicycle, public transport or car within a given time. These indicators are applied in 121 cities in 30 European countries. The project also developed an interactive visualisation tool that allows easy comparisons between the cities, destinations, transport modes, geographies and travel times. This study found that cities offer higher accessibility than their surrounding commuting zones (suburbs), due to more travel options and shorter travel distances, although car performance tends to be higher in commuting zones due to higher traffic speeds. In general, the car provides better accessibility than public transport or cycling, especially for longer travel times and in commuting zones. Bicycles provide high levels of local accessibility in most cities. Public transport performs well within a city, but in a commuting zone someone travelling by car can reach ten times more people than by public transport.

Urban Accessibility Explorer (<http://urbanaccessibility.com>)

The Metropolitan Chicago *Accessibility Explorer* is an easy-to-use mapping system that measures the number of activities, including various types of jobs, schools, parks, stores and libraries, that Chicago region neighborhood residents can reach within a given travel time, by a particular mode and time of day. The results are displayed on maps which can be adjusted by scale and area. This tool can help policy makers, planners and residents easily evaluate how transportation system and land use change could alter accessibility.

Best Practices

Below are recommendations for best practices when evaluating transportation and accessibility.

- Transportation should be evaluated based on *accessibility* rather than just *mobility*.
- Accessibility evaluation should consider all factors that may affect access, including people's needs and abilities, the availability and quality of various access options, land use factors, network connectivity, mobility substitutes and land use patterns.
- Transport planning should identify specific accessibility *constraints* in a particular situation (specific people, times, locations, types of travel, etc.). For example, traffic congestion may be a major constraint in some situations, while in others the constraint is inadequate user information, poor walkability, or high financial costs.
- Accessibility evaluation should give special consideration to the access needs of disadvantaged groups, including people with disabilities and low incomes. The quality of their access can be evaluated relative to average accessibility levels.
- Accessibility evaluation should account for qualitative factors such as user convenience, comfort, affordability, security and consumer preferences.
- Accessibility evaluation should account for the quality of modal integration, such as the quality of connections between modes.
- Accessibility analysis should consider various perspectives, including different individuals, groups, locations and activities.
- Analysis should consider ways that improving one form of access may reduce other forms, such as the tendency of wider roads and increased vehicle traffic to reduce pedestrian access, and the reduction in vehicle traffic speeds from traffic calming.
- Special consideration should be given to providing basic access and mobility, recognizing that certain types of access are particularly valued by society.
- Special consideration should be given to walkability because pedestrian access is important on its own, and supports other modes including ridesharing, public transit and automobile parking.
- Transportation planning should account for the benefits of inaccessibility and the external costs of vehicle traffic. Transportation policies should limit access and mobility when doing so preserves valuable social or environmental amenities.
- Transportation planning should consider a wide range of strategies for improving accessibility, including improvements to vehicle traffic, alternative modes, mobility management, mobility substitutes and more accessible land use.
- Transportation and land use planning should be integrated to optimize access. For example, land use policies should encourage clustering in areas that have good walking and cycling conditions, and good transit service.
- Transport planning should use neutral language that does not favor automobile transport over other modes, as illustrated in the box below.

Neutral Transport Planning Language (Lockwood 2004)

Many transport planning terms unintentionally favor motor vehicle travel over other forms of access. For example, increased road and parking capacity is often called an “improvement,” although wider roads and larger parking facilities, and the increased traffic volumes and speeds that result, tend to degrade pedestrian and cycling mobility. Calling such changes “improvements” indicates a bias in favor of one mode over others. Objective language uses neutral terms, such as “added capacity,” “additional lanes,” “modifications,” or “changes.”

The terms “traffic,” “flow,” and “trip” often refer only to motor vehicle travel. Short trips, non-motorized trips, travel by children, and non-commute trips are often undercounted or ignored in transport surveys, models, and analysis. Although automobile and transit trips often begin and end with a pedestrian or cycling link, they are often classified simply as “auto” or “transit” trips. Walking and cycling conditions are often evaluated inadequately or not at all.

The term “efficient” is frequently used to mean increased vehicle traffic speeds. This assumes that faster vehicle traffic always increases overall efficiency. This is not necessarily true. High vehicle speeds can reduce total traffic capacity, increase resource consumption, increase costs, reduce transportation options, increase crash risk, create less accessible land use patterns, and increase automobile dependency, reducing overall system efficiency.

Transportation professionals often rate the overall quality of the roadway network based on Level of Service (LOS) ratings that evaluate conditions for automobile traffic, but apply no comparable rating for other travel modes. It is important to indicate which users are considered when level of service values are reported.

Biased	Neutral Terms
Traffic	Motor vehicle traffic, pedestrian, bike traffic, etc.
Trips	Motor vehicle trips, person trips, bike trips, etc.
Improve	Change, modify, expand, widen
Enhance	Change, increase traffic speeds
Deteriorate	Change, reduce traffic speeds
Upgrade	Change, expand, widen, replace
Efficient	Faster, increased vehicle capacity
Level of service	Level of service for...

Examples:

Biased: *Level of service* at this intersection is rated “D.” The proposed *improvement* will cost \$100,000. This *upgrade* will make our transportation system more *efficient* by *enhancing* capacity, preventing *deterioration of traffic* conditions.

Neutral: *Level of service* at this intersection is rated “D” for motorists and “E” for pedestrians. A *right turn channel* would cost \$100,000. This *road widening project* will *increase motor vehicle traffic speeds and capacity* but may *reduce safety and convenience to pedestrian travel*.

Conclusions

Accessibility refers to people and businesses' ability to reach desired goods, services, activities and destinations. The quality of accessibility has many direct and indirect impacts on people and communities. Improving accessibility, and reducing the costs of accessibility, can help achieve many economic, social and environmental objectives.

Many factors affect accessibility, including people's transport needs and abilities, the quality and affordability of transport options, the degree to which various links and modes are connected, land use patterns, and the quality of mobility substitutes. This report describes these factors and how they can be evaluated. Some of these factors tend to be overlooked or undervalued in conventional transport planning, particularly nonmotorized travel demand, alternative mode service quality, user information, integration, affordability, prioritization and the value of inaccessibility.

Accessibility is the ultimate goal of most transportation activity, excepting the small amount of travel with no desired destination, so transport planning should generally be accessibility-based. Many current planning practices reflect *traffic-based* (vehicle movement) or *mobility-based* (people and goods movement) analysis. These tend to favor automobile transport over other forms of accessibility, including alternative modes, mobility management, and more accessible land use. Many of these planning and evaluation biases are subtle and technical, resulting from the way that transport is defined and measured, or reflecting the formulas used to allocate transportation funding.

The old transport planning paradigm tended to favor road and parking facility expansion, although, by inducing additional vehicle travel this tends to increase other problems. Urban roadway expansions often increase surface street traffic congestion (called *downstream* congestion), parking problems, traffic crashes, energy consumption and pollution emissions. Accessibility-based planning tends to expand the range of potential transportation improvement strategies (Table 15): it considers improvements to non-auto modes (walking, bicycling, ridesharing, public transport) and mobility substitutes (such as telework and delivery services that reduce the need for physical travel), TDM strategies that encourage travelers to use the most efficient option for each trip, increased transport network connectivity, improved user information and payment systems, and Smart Growth policies that create more compact and mixed communities. The new paradigm implements the combination of solutions that are most cost effective and beneficial overall, considering all impacts.

Accessibility-based planning is particularly important for achieving social equity goals. It recognizes the unique and important roles that walking, bicycling and public transport play in an efficient and equitable transport system. It recognizes common trade-offs between different modes, such as the tendency of wider roads and higher traffic speeds to degrade pedestrian and bicycle travel conditions, to the detriment of people who cannot, should not or prefer not to drive. It also recognizes location as an accessibility factor, and therefore the importance of evaluating where disadvantaged people live, and their ability to access basic services and activities such as schools, jobs, affordable grocery stores and healthcare.

Optimal planning requires more comprehensive analysis. No single method can evaluate all accessibility factors: a variety of methods are needed reflecting different impacts, scales and perspectives. Our ability to evaluate accessibility is improving as we develop a better

understanding of these concepts and better tools for quantifying accessibility impacts. However, accessibility-based planning techniques are still new and practitioners are still learning how to apply them to specific decisions. Effective accessibility evaluation therefore requires creativity and judgment.

Table 15 Accessibility Improvement Strategies

Factors	Improvement Strategies
Vehicle traffic flow	Improve traffic speed and capacity by paving roads and improving roadway design.
Prioritization	Use TDM incentives to favor higher-value trips and more efficient modes, such as efficient pricing, HOV priority lanes, curb regulations and parking management.
Mobility options	Improve walking, bicycling, rideshare, taxi, automobile, carsharing and public transport.
Mobility Substitutes	Improve telecommunications and delivery services that substitute for physical travel.
Network connectivity	Increase the density of sidewalk, path and roadway networks to allow more direct travel between destinations.
Complete streets	Ensure that urban streets accommodate diverse uses and users.
Intermodal connectivity	Improve connections between modes, such as transit station bicycle parking and airport transit services.
Proximity	Improve land use accessibility by increasing density and mix. Support transit-oriented development which creates walkable, compact and mixed villages around transit stations.
User Information	Improve the quantity and quality of user information regarding travel and location options, including signs, maps, brochures, websites and telephone services. Special attention can be given to providing convenient information on alternative modes and efficient locations.
Affordability	Improve affordable modes (walking, cycling, ridesharing, public transit, taxi and telework), and affordable housing in accessible locations.

This table indicates various ways to improve accessibility. Current transport planning practices tend to focus on just a few of these strategies, which limits the scope of solutions considered.

Improving accessibility evaluation can help reconcile conflicts inherent in current planning. Mobility-based planning favors solutions that increase motor vehicle travel, despite the diminishing benefits and increasing costs of expanding roads and parking facilities, and increasing vehicle traffic and personal mobility. A better understanding of accessibility can help identify truly optimal solutions to transport problems.

Accessibility-based planning expands the range of solutions that can be applied to solving transport problems, for example, by providing better user information, improving connections among modes, increasing the convenience and comfort of resource-efficient modes, and increasing land use accessibility. Taking advantage of these opportunities will require transport planning reforms that recognize their value.

References and Resources for More Information

Access Across America (<http://ao.umn.edu/research/america>) measures accessibility to jobs via various modes of transportation in major metropolitan areas across the United States.

Accessibility Observatory (<http://ao.umn.edu>) is a resource for the research and application of accessibility-based transportation system evaluation.

Alessandro Alasia, et al. (2017), *Measuring Remoteness and Accessibility - A Set of Indices for Canadian Communities*, Statistics Canada (www.statcan.gc.ca); at <https://bit.ly/2F8ll12>.

Paul Anderson, David Levinson and Pavithra Parthasarathi (2012), *Using Twin Cities Destinations and Their Accessibility as a Multimodal Planning Tool*, Center for Transportation Research (www.cts.umn.edu); at <https://conservancy.umn.edu/bitstream/121730/1/2012-05.pdf>.

Benjamin Baxter (2021), *Achieving Balance: Urban Mobility Measures Which Support Sustainability and Accessibility*, Eltis (www.eltis.org); at <https://bit.ly/3irku2q>.

Samikchhya Bhusal, Evelyn Blumenberg and Madeline Brozen (2021), *Access to Opportunities Primer*, UCLA Institute of Transportation Studies (www.lewis.ucla.edu); at <https://escholarship.org/uc/item/98g9d5p4>.

Marlon G. Boarnet, et al. (2017), *The Economic Benefits of Vehicle Miles Traveled (VMT)- Reducing Placemaking: Synthesizing a New View*, White Paper from the National Center for Sustainable Transportation (<https://ncst.ucdavis.edu>); at <https://escholarship.org/uc/item/5gx55278>.

Brookings Institution (2016), *Moving to Access Initiative*, Brookings Institution (www.brookings.edu); at www.brookings.edu/research/reports2/2016/05/moving-to-access:

Gilles Duranton and Erick Guerra (2016), *Developing a Common Narrative on Urban Accessibility: An Urban Planning Perspective*, Brookings Institution (www.brookings.edu); at <https://brook.gs/2F4oLlg>.

Jeffrey Gutman and Adie Tomer (2016), *Developing a Common Narrative on Urban Accessibility: Overview*, Brookings Institution (www.brookings.edu); at <https://brook.gs/2GVTER4>.

Christo Venter (2016), *Developing a Common Narrative on Urban Accessibility: Transportation Perspective*, Brookings Institution (www.brookings.edu); at <https://brook.gs/2R8VaUt>.

Shahid Yusuf (2016), *Developing a Common Narrative on Urban Accessibility: A Fiscal / Finance Perspective*, Brookings Institution (www.brookings.edu); at <https://brook.gs/2CQkhmk>.

Indaco Biazzo, Bernardo Monechi and Vittorio Loreto (2019), "General Scores for Accessibility and Inequality Measures in Urban Areas," *Royal Society Open Science* (<https://doi.org/10.1098/rsos.190979>).

Robert B. Case (2011), "Accessibility-Based Factors of Travel Odds: Performance Measures for Coordination of Transportation and Land Use to Improve Nondriver Accessibility," *Transportation Research Record 2242*, Transportation Research Board (www.trb.org), pp. 106-113; at <https://bit.ly/3bK6z57>.

CFS (2017), *The Geography of Time: Mapping Sydney's Effective Job and Service Density*, Committee for Sydney (www.sydney.org.au); at <https://pwc.to/2Qo1dzb>.

Chao-Lun Cheng and Asha Weinstein Agrawal (2010), "TTSAT: A New Approach to Mapping Transit Accessibility" *Journal of Public Transportation*, Vol. 13/1, pp. 55-72; at <https://bit.ly/3k5jSBG>.

Florie Di Ciommo (2018), *How the Inaccessibility Index Can Improve Transport Planning and Investment*, International Transport Forum (www.itf-oecd.org); at <https://bit.ly/2QHhwIz>.

CNT (2008), *Housing + Transportation Affordability Index*, Center for Neighborhood Technology (<http://htaindex.cnt.org>).

Pasquale Colonna (2009), "Mobility and Transport for our Tomorrow Roads," *Europeanroads Review* 14, Spring, pp. 44-53; at www.vtpi.org/colonna.pdf.

Commute Duration Dashboard (<https://bit.ly/3ARk65u>) by the Mineta Transportation Institute produces heatmaps showing commute duration and related information for most U.S. communities. One dashboard presents [Census tract](#) data and another shows [county level](#) data.

COST Accessibility Instruments (www.accessibilityplanning.eu) is a program to develop practical tools for accessibility planning.

CUBE Access (www.bentley.com/en/products/product-line/mobility-simulation-and-analytics/cube-access) is a GIS tool that can evaluate the quality of accessibility to various services and activities in a particular community.

DfT, *2003 National Travel Survey*, UK Dept. for Transport (www.transtat.dft.gov.uk), 2003.

Richard Dowling, et al. (2008), *Multimodal Level Of Service Analysis For Urban Streets*, NCHRP Report 616, TRB (www.trb.org); at http://trb.org/news/blurbs_detail.asp?id=9470; *User Guide* at http://onlinepubs.trb.org/onlinepubs/nchrp/nchrp_w128.pdf.

Andres Duany and Robert Steuteville (2021), *Defining the 15-minute City*, Public Square (www.cnu.org); at www.cnu.org/publicsquare/2021/02/08/defining-15-minute-city.

Ahmed El-Geneidy and David Levinson (2021), "Making Accessibility Work in Practice," *Transport Reviews* (DOI: 10.1080/01441647.2021.1975954).

Jonas Eliasson (2020), *Reconciling Accessibility Benefits with User Benefits*, International Transport Forum (www.itf-oecd.org); at <https://bit.ly/3fpOrjS>.

David Engwicht (1993), *Reclaiming Our Cities and Towns: Better Living with Less Traffic*, New Society Publishers (www.newsociety.com).

Reid Ewing and Shima Hamidi (2014), *Measuring Urban Sprawl and Validating Sprawl Measures*, Metropolitan Research Center at the University of Utah for the National Cancer Institute, the Brookings Institution and Smart Growth America (www.smartgrowthamerica.org); at www.arch.utah.edu/cgi-bin/wordpress-metroresearch.

Evaluating Accessibility for Transportation Planning
Victoria Transport Policy Institute

Yingling Fan and Arthur Huang (2011), *How Affordable is Transportation? An Accessibility-Based Evaluation*, CTS Report 11-12, Transitway Impacts Research Program, Center for Transportation Studies (www.cts.umn.edu); at <https://bit.ly/2O0s5aW>.

Steven Farber and Antonio Páez (2009), "My Car, My Friends, and Me: A Preliminary Analysis of Automobility and Social Activity Participation," *Journal of Transport Geography*, Vol. 17, pp. 216–225 (www.sciencedirect.com/science/article/pii/S0966692308000665).

FDOT (2007), *Quality/Level of Service Handbook*, Florida Department of Transportation (www.dot.state.fl.us/Planning/systems/sm/los/default.htm).

William Garrison and David Levinson (2014), *The Transportation Experience: Second Edition*, Transportist (<https://transportist.org>); at <https://bit.ly/3mOUFs1>.

Vikash V. Gayah (2012), "Two-Way Street Networks: More Efficient than Previously Thought?" *Access* 41, Fall, pp. 10-15; at www.uctc.net/access/41/access41-2way.pdf.

Karst T. Geurs (2018), *Transport Planning With Accessibility Indices in the Netherlands*, International Transport Forum (www.itf-oecd.org); at <https://bit.ly/2DfuXNx>.

Susan Handy (1993), "Regional Versus Local Accessibility; Neo-Traditional Development and its Implications for Non-Work Travel," *Built Environment*, Vol. 18, No.4, 1993, pp. 253-267; also available at University of California Transportation Center (Berkeley), #234 (www.uctc.net).

Susan Handy (1994), "Highway Blues: Nothing a Little Accessibility Can't Cure," *Access* 5 (www.uctc.net), pp. 3-7; at www.uctc.net/access/access05.pdf.

Walter G. Hansen (1959), "How Accessibility Shapes Land Use," *Journal of the American Institute of Planners*, Vol. 35, No. 2, pp. 73-76.

Daniel Herriges (2018), *The Difference Between Mobility and Accessibility*, Strong Towns (www.strongtowns.org); at <https://bit.ly/3df88Zf>.

Michael Iacono, Kevin Krizek and Ahmed El-Geneidy (2008), *Access to Destinations: How Close is Close Enough? Estimating Accurate Distance Decay Functions for Multiple Modes and Different Purposes*, Report 2008-11, University of Minnesota (www.cts.umn.edu).

Aliasgar Inayathusein and Simon Cooper (2018), *London's Accessibility Indicators: Strengths, Weaknesses and Challenges*, Discussion Paper, International Transport Forum (www.itf-oecd.org); at www.itf-oecd.org/sites/default/files/docs/london-accessibility-indicators.pdf.

ITF (2017), *Linking People and Places: New Ways of Understanding Spatial Access in Cities*, International Transport Forum (www.itf-oecd.org); at <https://bit.ly/2ZfSbuF>.

ITF (2019), *Improving Transport Planning and Investment Through the Use of Accessibility Indicators*, International Transport Forum (www.itf-oecd.org); at <https://bit.ly/2UilKAU>.

ITF (2019), *Benchmarking Accessibility in Cities: Measuring the Impact of Proximity and Transport Performance*, Paper 68, International Transport Forum (www.itf-oecd.org); at <https://bit.ly/2VqvgvK>.

Evaluating Accessibility for Transportation Planning
Victoria Transport Policy Institute

ITF (2020), *Accessibility and Transport Appraisal*, International Transport Forum (www.itf-oecd.org); at www.itf-oecd.org/accessibility-and-transport-appraisal.

JRC (2011), *Location Efficiency and Housing Type—Boiling it Down to BTUs*, Jonathan Rose Companies for the U.S. Environmental Protection Agency (www.epa.gov); at www.epa.gov/smartgrowth/pdf/location_efficiency_BTU.pdf.

Kevin Kane, Jae Hong Kim and John R. Hipp (2017), *What Makes Housing Accessible to Everyday Destinations in Southern California?* Metropolitan Futures Initiative (<http://mfi.soceco.uci.edu>); at http://mfi.soceco.uci.edu/files/2017/04/UCi17_MFI_Report5_v2.pdf.

Sarah M. Kaufman, et al. (2014), *Mobility, Economic Opportunity and New York City Neighborhoods*, Rudin Center for Transportation (www.wagner.nyu.edu); at <http://bit.ly/2rLRW8E>.

Kevin Krizek, et al. (2009), *Access to Destinations: Application of Accessibility Measures for Non-Auto Travel Modes*, Report No. 9, Access to Destinations Study, University of Minnesota's Center for Transportation Studies (www.cts.umn.edu/access-study/publications); at www.cts.umn.edu/Publications/ResearchReports/reportdetail.html?id=1808.

Kara Kockelman (1997), "Travel Behavior as a Function of Accessibility, Land Use Mixing, and Land Use Balance: Evidence from the San Francisco Bay Area," *Transportation Research Record 1607*, TRB (www.trb.org); at www.ce.utexas.edu/prof/kockelman.

Leigh, Scott and Cleary (1999), *Transit Needs & Benefits Study*, Colorado Department of Transportation (www.dot.state.co.us).

Jonathan Levine, et al. (2012), "Does Accessibility Require Density or Speed?" *Journal of the American Planning Association*, Vol. 78, No. 2, pp. 157-172, <http://dx.doi.org/10.1080/01944363.2012.677119>; at <http://tinyurl.com/cpdmmf6>. Also see *Metropolitan Accessibility: Comparative Indicators for Policy Reform* (www.umich.edu/~umaccess).

Jonathan Levine, Joe Grengs and Louis A. Merlin (2019), *From Mobility to Accessibility: Transforming Urban Transportation and Land-Use Planning*, Cornell Press (www.cornellpress.cornell.edu).

Jonathan Levine (2020), *The Accessibility Shift Conceptual Obstacles and How to Overcome (One of) Them: Discussion Paper*, Roundtable 182, International Transport Forum (www.itf-oecd.org); at www.itf-oecd.org/sites/default/files/docs/accessibility-shift.pdf.

David Levinson (2013), *Access Across America*, Report 13, Access to Destinations Study, Center for Transportation at the University of Minnesota (www.cts.umn.edu); at www.cts.umn.edu/Publications/ResearchReports/pdfdownload.pl?id=2280.

David Levinson (2016), *Spontaneous Access: Reflexions on Designing Cities and Transport*, The Transportationist (<https://transportist.org>); <https://transportist.org/2016/10/17/spontaneous-access-reflexions-on-designing-cities-and-transport>.

David M. Levinson (2019), *The 30-Minute City: Designing for Access*, Transportist (<https://transportist.org>); at <https://transportist.org/books/the-30-minute-city-designing-for-access>.

Evaluating Accessibility for Transportation Planning
Victoria Transport Policy Institute

David M. Levinson and David A. King (2019), *A Political Economy of Access*, Transportist (<https://transportist.org>); at <https://transportist.org/books/a-political-economy-of-access>.

David M. Levinson and Kevin J. Krizek (2017), *The End of Traffic and the Future of Access: A Roadmap to the New Transport Landscape*, Transportist (<https://transportist.org>); at <https://transportist.org/books/the-end-of-traffic-and-the-future-of-transport>.

David M. Levinson and Kevin J. Krizek (2018), *Metropolitan Transport and Land Use: Planning for Place and Plexus*, Transportist (<https://transportist.org>); at <https://transportist.org/books/planning-for-place-and-plexus-metropolitan-land-use-and-transport>.

David M. Levinson, Wes Marshall and Kay Axhausen (2018), *Elements of Access: Transport Planning for Engineers, Transport Engineering for Planners*, Transportist (<https://transportist.org>); at <https://transportist.org/books/elements-of-access>.

David Levinson and David King (2020), *Transport Access Manual: A Guide for Measuring Connection between People and Places*, Committee of the Transport Access Manual, University of Sydney (<https://ses.library.usyd.edu.au>); at <https://hdl.handle.net/2123/23733>.

David M. Levinson and Hao Wu (2020), "Towards a General Theory of Access," *Journal of Transport and Land Use*, Vo. 13(1), pp. 129-158 (<https://doi.org/10.5198/jtlu.2020.1660>).

Michael Lewyn (2014), *Job Sprawl and Commuting Times*, Planetizen (www.planetizen.com/node/68744).

Chris Lightfoot and Tom Steinberg (2006), *Travel-time Maps and Their Uses*, My Society (www.mysociety.org/2006/travel-time-maps/index.php). This website describes how 'Travel-time Maps' can be used to indicate the time needed to travel to various destinations.

Todd Litman (2001), "You Can Get There from Here: Evaluating Transportation Choice," *Transportation Research Record 1756*, Transportation Research Board (www.trb.org), pp. 32-41; at www.vtppi.org/choice.pdf.

Todd Litman (2003), "Measuring Transportation: Traffic, Mobility and Accessibility," *ITE Journal* (www.ite.org), Vol. 73, No. 10, October 2003, pp. 28-32; at www.vtppi.org/measure.pdf.

Todd Litman (2005), *Evaluating Transportation Land Use Impacts*, VTPI (www.vtppi.org); at www.vtppi.org/landuse.pdf.

Todd Litman (2006a), *Transportation Cost and Benefit Analysis*, VTPI (www.vtppi.org); at www.vtppi.org/tca.

Todd Litman (2006b), "Transportation Market Distortions," *Berkeley Planning Journal* (www-dcrp.ced.berkeley.edu/bpj), Volume 19, 2006, pp. 19-36; at www.vtppi.org/distortions_BPJ.pdf.

Todd Litman (2007a), *Socially Optimal Transport Prices and Markets*, VTPI (www.vtppi.org); at www.vtppi.org/sotpm.pdf.

Todd Litman (2007b), *Comprehensive Transport Planning*, VTPI (www.vtppi.org); at www.vtppi.org/comprehensive.pdf.

Todd Litman (2013), "The New Transportation Planning Paradigm," *ITE Journal* (www.ite.org), Vol. 83, June, pp. 20-28; at www.vtppi.org/paradigm.pdf.

Ian M. Lockwood (2004), *Transportation Prescription for Healthy Cities*, Glatting Jackson Transportation Urban Design Studio, for presentation and Common Ground www.glatting.com/PDF/IML_RWJF_Paper2004.pdf.

Karel Martens (2006), "Basing Transport Planning on Principles of Social Justice," *Berkeley Planning Journal*, Volume 19 (www-dcrp.ced.berkeley.edu/bpj).

Karel Martens (2020), *A People-Centred Approach to Accessibility: Discussion Paper*, Roundtable 182, International Transport Forum (www.itf-oecd.org); at <https://bit.ly/3hda71E>.

Jeremy Mattson (2012), *Travel Behavior and Mobility of Transportation-Disadvantaged Populations: Evidence from the National Household Travel Survey*, Upper Great Plains Transportation Institute (www.ugpti.org), North Dakota State University; at www.ugpti.org/pubs/pdf/DP258.pdf.

Chris McCahill, Matt Pettit and Chris Sinclair (2017), *Access Scores – Measuring the Why, Where and How of Accessibility*, Citilabs (www.citilabs.com); at <https://bit.ly/2p2ueHY>.

David Metz (2008), *The Limits to Travel: How Far Will You Go?* Earthscan (www.earthscan.co.uk).

Inshu Minocha, et al. (2008), *Analysis of Transit Quality of Service and Employment Accessibility for the Greater Chicago Region*, Transportation Research Board 87th Annual Meeting (www.trb.org).

Patricia Mokhtarian and Ilan Salomon (2001), "How Derived is the Demand for Travel? Some Conceptual and Measurement Considerations," *Transportation Research A*, Vol. 35, No. 8 (www.elsevier.com/locate/tra) September 2001, pp. 695-719.

NAR (2011-2017), *National Community Preference Survey*, National Association of Realtors (www.realtor.org); at www.nar.realtor/reports/nar-2017-community-preference-survey.

Opportunity Score (<https://labs.redfin.com/opportunity-score>) ranks locations in 350 U.S. cities based on the number of jobs that can be accessed within a 30-minute walk or transit ride.

Andrew Owen and David Levinson (2014), *Access Across America: Transit 2014*, CTS 14-11, Accessibility Observatory, University of Minnesota (www.cts.umn.edu).

Andrew Owen, Brendan Murphy and David M. Levinson (2018), *Access Across America: Auto 2016*, Report no. CTS 18-08, Center for Transportation Studies (www.cts.umn.edu); at <https://bit.ly/2Fpgq2M>.

Elias Pajares, et al., "Accessibility by Proximity: Addressing the Lack of Interactive Accessibility Instruments for Active Mobility," *Journal of Transport Geography*, Vo. 93 (<https://doi.org/10.1016/j.jtrangeo.2021.103080>).

Chelsey Palmateer, Andrew Owen and David M. Levinson (2016), *The Synergistic Effects of Transit Oriented Development and Transit Hubs on Accessibility in the San Francisco Bay Area*, University of Minnesota ; at <http://hdl.handle.net/11299/181535>.

Evaluating Accessibility for Transportation Planning
Victoria Transport Policy Institute

David G. Proffitt, et al. (2019), "Accessibility Planning in American Metropolitan Areas: Are We There Yet?" *Urban Studies*, Vol. 56(1), pp. 167-192 (<https://doi.org/10.1177/0042098017710122>).

Portland (2012), *Portland Plan: 20 Minute Neighborhood*, City of Portland (www.portlandonline.com/portlandplan); at <https://bit.ly/1P2sRNO>.

Stacy Rendall, et al. (2011), "Quantifying Transport Energy Resilience: Active Mode Accessibility," *Transportation Research Record* 2242, TRB (www.trb.org), pp. 72-80; at <http://amonline.trb.org/1213tc/1>.

Revision (http://revision.lewis.ucla.edu/?mc_cid=6d7654de44&mc_eid=b8e4b2304e) is a regional mapping and analysis program that integrates a range of public and private data for sustainable communities planning and trend visualization. It provides a common regional performance monitoring tool for sustainable community indicators.

Philipp Rode and Graham Floater (2014), *Accessibility in Cities: Transport and Urban Form*, NCE Cities – Paper #3, by the London School of Economics' LSE Cities program (www.lsecities.net), for the Global Commission on the Economy and Climate's New Climate Economy Cities Program (www.newclimateeconomy.net); at <https://bit.ly/1vaXLji>.

DW Rowlands (2020), *Understanding Walkable Density*, City Observatory (<http://cityobservatory.org>); at <http://cityobservatory.org/understanding-walkable-density>.

William Ross (2000), "Mobility and Accessibility: The Yin and Yang of Planning," *World Transport Policy & Practice* (www.ecoplan.org/wtpp/wtj_index.htm), Vol. 6, No. 2 pp. 13-19.

Laura Sandt, Tabitha Combs and Jesse Cohn (2017), *Pursuing Equity in Pedestrian and Bicycle Planning*, Federal Highway Administration (www.fhwa.dot.gov); at <https://bit.ly/2lln7nk>.

K. H. Schaeffer and Elliot Sclar (1980), *Access for All*, Columbia University Press (New York).

Jay S. Shah and Bhargav Adhvaryu (2016), "Public Transport Accessibility Levels for Ahmedabad, India," *Journal of Public Transportation*, 19 (3): 19-35 (DOI: <http://dx.doi.org/10.5038/2375-0901.19.3.2>); at <http://scholarcommons.usf.edu/jpt/vol19/iss3/2>.

Fariba Siddiq and Brian D. Taylor (2021), "Tools of the Trade?," *Journal of the American Planning Association* (DOI: 10.1080/01944363.2021.1899036); summarized in, *Is Accessibility Evaluation Ready for Prime Time?* (<https://bit.ly/3E4UYJD>).

Smart Location Mapping (www.epa.gov/smartgrowth/smart-location-mapping) provides interactive maps and data for measuring location efficiency including built environment impacts on per capita vehicle travel, and methods for measuring multimodal accessibility for people and employers.

Spatial Network Analysis For Multi-Modal Urban Transport Systems (www.snamuts.com) evaluates the accessibility of a region's current public transport network.

SSTI (2018), *Modernizing Mitigation: A Demand-Centered Approach*, State Smart Transportation Initiative (www.ssti.us) and the Mayors Innovation Project; at <https://bit.ly/3hqEzoi>.

Evaluating Accessibility for Transportation Planning
Victoria Transport Policy Institute

SSTI (2021), *Measuring Accessibility: A Guide for Transportation and Land Use Practitioners*, State Smart Transportation Initiative (<https://ssti.us>); at <https://ssti.us/accessibility-analysis>.

Street Smart (www.thinkstreetsmart.org) is a clearinghouse that provides comprehensive information for integrating climate change, public health, and equity concerns into transportation.

Eric Sundquist, Chris McCahill and Logan Dredske (2018), *Accessibility in Practice: A Guide for Transportation and Land Use Decision Making*, State Smart Transportation Initiative (www.ssti.us); at www.vtrans.org/resources/Accessibility_Guide_Final.pdf.

Adie Tomer, Joseph Kane, and Jennifer S. Vey (2020), *Connecting People and Places: Exploring New Measures of Travel Behavior*, Brookings Institute (www.brookings.edu); at <https://brook.gs/3j84amd>. Also see, *We Should Design Cities for Shorter Distances, Not Faster Speeds*, <https://brook.gs/3pe37V0>.

Transport Geography on the Web (www.people.hofstra.edu/geotrans) is an Internet resource to promote access to transport geography information.

Travel Time and Housing Price Maps (www.mysociety.org/2007/more-travel-maps/morehousing). Interactive mapping system shows travel times and housing costs for various locations in London.

Toolbox for Regional Policy Analysis Website (www.fhwa.dot.gov/planning/toolbox/index.htm) by the US Federal Highway Administration, describes analytical methods for evaluating regional economic, social and environmental impacts of various transportation and land use policies.

Urban Accessibility Explorer (<http://urbanaccessibility.com>) is an easy-to-use mapping system that measures the number of activities, including various types of jobs, schools, parks, stores and libraries, that can be reached by residents of a specified neighborhood within a given amount of travel time, by a particular mode and time of day in the Chicago Metropolitan area.

VTPi (2006), *Online TDM Encyclopedia*, Victoria Transport Policy Institute (www.vtpi.org/tdm).

Jarrett Walker (2021), *Basics: Access, or the Wall Around Your Life*, Human Transit (<https://humantransit.org>); at <https://bit.ly/2ZUWnof>.

Jake Wiersma, Luca Bertolini and Thomas Straatemeier (2017), "How Does the Spatial Context Shape Conditions for Car Dependency? An Analysis of the Differences Between and Within Regions in the Netherlands," *Journal of Transport and Land Use*, Vol . 9/3, pp. 35-55; at <https://bit.ly/2m2UhOy>.

Hao Wu, et al. (2021), "Urban Access Across the Globe: An International Comparison of Different Transport Modes," *Urban Sustainability*, (<https://doi.org/10.1038/s42949-021-00020-2>); at www.nature.com/articles/s42949-021-00020-2.pdf.

Xiang Yan (2021), "Toward Accessibility-Based Planning," *Journal of the American Planning Association*, (DOI: 10.1080/01944363.2020.1850321).

Acknowledgements

Thanks to Sumit Adhikari, William Ross, John Ernst and John Ho for contributions to this report.

www.vtpi.org/access.pdf