

Fisher™ 3582 and 3582i Positioners and 582i Electro-Pneumatic Converter

Contents

Introduction	2
Scope of Manual	2
Description	2
Type Number Descriptions	5
Specifications	6
Educational Services	6
Installation	6
Hazardous Area Classifications and Special Instructions for “Safe Use” and Installation in Hazardous Areas for 582i Converter	8
Mounting	9
Changing Cam Position	14

Pressure Connections	14
Supply Connection	14
Output Connection	16
Instrument Connection	16
Diagnostic Connections	16
Vent	17
Electrical Connections for 3582i	
Valve Positioner	17
582i Converter Installation	19
Operating Information	20
Valve Positioner Cam Information	20

(continued on page 2)

Figure 1. Typical Mounting for Fisher 3582 and 3582i Positioners



CONTROL VALVE WITH
3582 POSITIONER



CONTROL VALVE WITH
3582i POSITIONER

Contents (cont'd)

Valve Positioner Bypass Operation	22
Input Signal Ranges	22
Valve Positioner Split-Range Operation	23
Changing Valve Positioner Action	23
Calibration Of Valve Positioner	24
Beam Alignment	24
Calibration	26
Principle of Operation	27
3582 Valve Positioners	27
3582i Valve Positioner	28
Maintenance	29
Changing the Range Spring	30

Replacing Gaskets	30
Replacing the Nozzle O-Ring	31
Replacing the Relay	31
Adjusting the Flapper Pivot	32
Replacing the 582i Converter	
Primary O-Ring and Filter	32
Replacing the 582i Converter Housing	
Cap O-Ring	32
Removing the 582i Converter	32
Reassembling the 582i Converter	33
Parts Ordering	34
Parts Kits	34
Parts List	35

Introduction

Scope of Manual

This instruction manual includes installation, operation, calibration, maintenance, and parts ordering information for Fisher 3582 pneumatic valve positioners and the 3582i electro-pneumatic valve positioner. Refer to separate instruction manuals for information on the control valve, actuator, and accessories.



Do not install, operate or maintain a 3582 pneumatic valve positioner or a 3582i electro-pneumatic valve positioner without being fully trained and qualified in valve, actuator and accessory installation, operation and maintenance. To avoid personal injury or property damage it is important to carefully read, understand, and follow all of the contents of this manual, including all safety cautions and warnings. If you have any questions about these instructions, contact your [Emerson sales office](#) before proceeding.

Description

3582 pneumatic valve positioners and the 3582i electro-pneumatic valve positioner shown in figure 1 are used with diaphragm-actuated, sliding-stem control valve assemblies. The pneumatic valve positioners receive a pneumatic input signal from a control device and modulate the supply pressure to the control valve actuator. The positioner adjusts the actuator supply pressure to maintain a valve stem position proportional to the pneumatic input signal.

3582NS positioners are designed for nuclear power applications. The 3582NS construction includes materials that provide superior performance at elevated temperature and radiation levels. The O-rings are EPDM (ethylene propylene) and the diaphragms are EPDM/meta-aramid fabric. EPDM demonstrates superior temperature capability and shelf life over nitrile. The meta-aramid diaphragm fabric demonstrates improved strength retention at elevated temperature and radiation conditions.

CAUTION



Use a clean, dry, oil-free air supply with instruments containing EPDM components. EPDM is subject to degradation when exposed to petroleum-based lubricants.

Table 1. Specifications for Fisher 3582 and 3582i Valve Positioners

<p>Note: Specifications for 3582 positioners include 3582A, 3582C, 3582D, 3582G, and 3582NS unless otherwise indicated</p> <p>Available Configurations Refer to Type Number Descriptions on page 5</p> <p>Input Signal 3582: ■ 0.2 to 1.0 bar (3 to 15 psig), ■ 0.4 to 2.0 bar (6 to 30 psig), or ■ split range, see table 5 3582i: 4 to 20 mA DC constant current with 30 VDC maximum compliance voltage, can be split range, see table 5</p> <p>Equivalent Circuit for 3582i The 582i converter equivalent circuit is 120 ohms, shunted by three 5.6-volt zener diodes (see figure 10)</p> <p>Output Signal Type: Pneumatic pressure as required by actuator up to 95 percent of maximum supply Action: Field-reversible between ■ direct and ■ reverse within the pneumatic valve positioner</p> <p>Supply Pressure⁽¹⁾ Recommended: 0.3 bar (5 psi) above actuator requirement Maximum: 3.4 bar (50 psig) or pressure rating of actuator, whichever is lower Supply Medium: Air or Natural Gas Supply medium must be clean, dry, and noncorrosive Per ISA Standard 7.0.01 A maximum 40 micrometer particle size in the air system is acceptable. Further filtration down to 5 micrometer particle size is recommended. Lubricant content is not to exceed 1 ppm weight (w/w) or volume (v/v) basis. Condensation in the air supply should be minimized Per ISO 8573-1 Maximum particle density size: Class 7 Oil content: Class 3 Pressure Dew Point: Class 3 or at least 10°C less than the lowest ambient temperature expected Note: The 3582i is not approved for use with natural gas as the supply medium</p>	<p>Input Bellows Pressure Rating⁽¹⁾ See table 4 for minimum and maximum pressure ratings (allowable input signal) for each available range spring</p> <p>Maximum Steady-State Air Consumption⁽²⁾ 3582 1.4 bar (20 psig) Supply: 0.38 normal m³/hr (14.0 scfh) 2.0 bar (30 psig) Supply: 0.48 normal m³/hr (18.0 scfh) 2.4 bar (35 psig) Supply: 0.54 normal m³/hr (20.0 scfh) 3582i 1.4 bar (20 psig) Supply: 0.46 normal m³/hr (17.2 scfh) 2.0 bar (30 psig) Supply: 0.57 normal m³/hr (21.4 scfh) 2.4 bar (35 psig) Supply: 0.64 normal m³/hr (23.8 scfh)</p> <p>Maximum Supply Air Demand 1.4 bar (20 psig) Supply: 4.4 normal m³/hr (164.5 scfh) 2.0 bar (30 psig) Supply: 6.7 normal m³/hr (248.5 scfh) 2.4 bar (35 psig) Supply: 7.7 normal m³/hr (285.5 scfh)</p> <p>Performance 3582 Independent Linearity: ±1 percent of output signal span Hysteresis: 0.5 percent of span 3582i Independent Linearity: ±2 percent of output signal span Hysteresis: 0.6 percent of span Electromagnetic Compatibility for 582i electro-pneumatic converter Meets EN 61326-1:2013 Immunity—Industrial locations per Table 2 of the EN 61326-1 standard. Performance is shown in table 2 below. Emissions—Class A ISM equipment rating: Group 1, Class A Note: The electromagnetic compatibility specifications also apply to the 3582i 3582 and 3582i Typical Open Loop Gain (Output Signal): ■ 100 in the range of 0.2 to 1.0 bar (3 to 15 psig) ■ 55 in the range of 0.4 to 2.0 bar (6 to 30 psig) 3582 and 3582i Typical Open Loop Gain (Output Signal): ■ 100 in the range of 0.2 to 1.0 bar (3 to 15 psig) ■ 55 in the range of 0.4 to 2.0 bar (6 to 30 psig)</p>
---	---

- continued -

Table 1. Specifications for Fisher 3582 and 3582i Valve Positioners (Continued)

<p>Operating Influences</p> <p>Supply Pressure—3582: Valve travel changes less than 1.67 percent per bar (0.25 percent per 2 psi) change in supply pressure</p> <p>Supply Pressure—3582i: Valve travel changes less than 3.62 percent per bar (1.5 percent per 2 psi) change in supply pressure</p> <p>Operative Temperature Limits⁽¹⁾</p> <p>Standard Construction</p> <p>3582 and 3582i: -40 to +71°C (-40 to +160°F)</p> <p>3582NS: -40 to +82°C (-40 to +180°F) with EPDM elastomers</p> <p>High-Temperature Construction</p> <p>3582A and C only: -18 to +104°C (0 to +220°F) without gauges</p> <p>Electrical Classification for 582i</p> <p>CSA—Intrinsically Safe, Explosion proof, Type n, Dust-Ignition proof, DIV 2</p> <p>FM—Intrinsically Safe, Explosion proof, Type n, Non-incendive, Dust-Ignition proof</p> <p>ATEX—Intrinsically Safe, Flameproof, Type n</p> <p>IECEX—Intrinsically Safe, Flameproof, Type n</p> <p>Note: These classifications also apply to the 3582i positioner</p> <p>Housing Classification for 582i</p> <p>CSA—Type 3 Encl.</p> <p>FM—NEMA 3, IP54</p> <p>ATEX—IP64</p> <p>IECEX—IP54</p> <p>Mount instrument with vent on the side or bottom if weatherproofing is a concern.</p> <p>Note: These classifications also apply to the 3582i positioner</p> <p>Other Classifications/Certifications</p> <p>CUTR—Customs Union Technical Regulations (Russia, Kazakhstan, Belarus, and Armenia)</p> <p>INMETRO—National Institute of Metrology, Quality and Technology (Brazil)</p> <p>KTL—Korea Testing Laboratory (South Korea)</p> <p>CCC—China Compulsory Compliance</p> <p>NEPSI—National Supervision and Inspection Centre for Explosion Protection and Safety of Instrumentation (China)</p>	<p>Contact your Emerson sales office for classification/certification specific information</p> <p>Hazardous Area Classification for 3582</p> <p>3582 valve positioners comply with the requirements of ATEX Group II Category 2 Gas and Dust</p> <p>  II 2 G D Ex h IIC Tx Gb Ex h IIIC Tx Db</p> <p>Maximum surface temperature (Tx) depends on operating conditions</p> <p>Gas: T4, T5, T6</p> <p>Dust: T85...T104</p> <p>Note: This rating does not apply to the 3582i</p> <p>Pressure Gauges</p> <p>40 mm (1.5 inch) diameter with plastic case and brass connection ■ triple scale (PSI, MPa, and bar) or ■ dual scale (PSI and kg/cm²)</p> <p>Pressure Connections</p> <p>1/4-18 NPT</p> <p>Electrical Connection for 3582i</p> <p>1/2-14 NPT conduit connection</p> <p>Maximum Valve Stem Travel</p> <p>105 mm (4.125 inches); adjustable to obtain lesser travels with standard input signals</p> <p>Characterized Cams</p> <p>See characterized cams section</p> <p>Approximate Weight</p> <p>3582: 2.5 kg (5.5 pounds)</p> <p>3582i: 3.6 kg (8 pounds)</p> <p>Declaration of SEP</p> <p>Fisher Controls International LLC declares this product to be in compliance with Article 4 paragraph 3 of the PED Directive 2014/68/EU. It was designed and manufactured in accordance with Sound Engineering Practice (SEP) and cannot bear the CE marking related to PED compliance.</p> <p>However, the product <i>may</i> bear the CE marking to indicate compliance with <i>other</i> applicable European Community Directives.</p>
--	---

NOTE: Specialized instrument terms are defined in ANSI/ISA Standard 51.1 - Process Instrument Terminology.

1. The pressure and temperature limits in this document and any applicable standard or code limitation should not be exceeded.

2. Normal m³/hr—normal cubic meters per hour (0°C and 1.01325 bar, absolute); Scfh—Standard cubic feet per hour (60°F and 14.7 psia).

Table 2. Fisher 582i Electro-Pneumatic Converter⁽¹⁾ EMC Summary Results—Immunity

Port	Phenomenon	Basic Standard	Test Level	Performance Criteria ⁽²⁾
Enclosure	Electrostatic Discharge (ESD)	IEC 61000-4-2	4 kV contact 8 kV air	A
	Radiated EM field	IEC 61000-4-3	80 to 1000 MHz @ 10V/m with 1 kHz AM at 80% 1400 to 2000 MHz @ 3V/m with 1 kHz AM at 80% 2000 to 2700 MHz @ 1V/m with 1 kHz AM at 80%	A
	Rated power frequency magnetic field	IEC 61000-4-8	60 A/m at 50 Hz	A
I/O signal/control	Burst (fast transients)	IEC 61000-4-4	1 kV	A
	Surge	IEC 61000-4-5	1 kV (line to ground only, each)	B
	Conducted RF	IEC 61000-4-6	150 kHz to 80 MHz at 3 Vrms	A

Specification limit = ±1% of span
 1. The information contained in the table also applies to the 3582i positioner.
 2. A = No degradation during testing, B = Temporary degradation during testing, but is self-recovering.

Description (continued)

Under the 10CFR50, Appendix B, quality assurance program, the 3582NS positioner is qualified commercial grade dedicated. These can be supplied as 10CFR, Part 21 items.

The 3582i is an electro-pneumatic valve positioner, consisting of a 582i electro-pneumatic converter installed on a 3582 pneumatic valve positioner. The 3582i valve positioner provides an accurate valve stem position that is proportional to a DC current input signal.

The 582i electro-pneumatic converter is a modular unit that can be installed at the factory or in the field. However, do not install a 582i converter on an existing positioner until you contact your [Emerson sales office](#) for application assistance.

The 582i converter receives the DC current input signal and, through a nozzle/flapper arrangement, provides a proportional pneumatic output signal. This pneumatic output signal provides the input signal to the pneumatic valve positioner, eliminating the need for a remote-mounted transducer.

Refer to the type number description for a detailed explanation of type numbers.

Type Number Descriptions

The Fisher 3582 series of positioners include the models listed below.

The following descriptions provide specific information on the different valve positioner constructions. If the type number is not known, refer to the nameplate on the positioner. For the location of the nameplate, refer to key 25 in figure 20.

3582—Pneumatic valve positioner with bypass and instrument, supply, and output pressure gauges.

3582A—Pneumatic valve positioner without bypass and without pressure gauges.

3582C—Pneumatic valve positioner without bypass and with automotive tire valves instead of pressure gauges.

3582D—Pneumatic valve positioner with bypass and with automotive tire valves instead of pressure gauges.

3582G—Pneumatic valve positioner without bypass and with instrument, supply, and output pressure gauges.

3582NS—Pneumatic valve positioner for nuclear service applications with or without bypass and with automotive tire valves instead of pressure gauges.

3582i—Electro-pneumatic valve positioner without bypass; with 582i converter; and with: supply and output pressure gauges, automotive tire valves, or pipe plugs.

582i—Electro-pneumatic converter with: supply and output pressure gauges, automotive tire valves, or pipe plugs. Used for conversion of a 4-20 mA input signal to a 0.2 to 1.0 bar (3 to 15 psig) input signal for the pneumatic valve positioner.

Specifications

Specifications for the valve positioners are shown in table 1.

Refer to the unit nameplate to determine the type of positioner, supply pressure, etc.

⚠ WARNING

This product is intended for a specific current range, temperature range and other application specifications. Applying different current, temperature and other service conditions could result in malfunction of the product, property damage or personal injury.

Educational Services

For information on available courses for 3852 and 3582i, as well as a variety of other products, contact:

Emerson Automation Solutions
Educational Services, Registration
Phone: +1-641-754-3771 or +1-800-338-8158
e-mail: education@emerson.com
emerson.com/fishervalvetraining

Installation

If using natural gas as the pneumatic supply medium, natural gas will be used in the pressure connections of the unit to any connected equipment. The unit will vent natural gas into the surrounding atmosphere, unless it is remote vented.

⚠ WARNING

Always wear protective clothing, gloves, and eyewear when performing any installation operations to avoid personal injury.

If installing into an existing application, also refer to the WARNING at the beginning of the Maintenance section in this instruction manual.

Check with your process or safety engineer for any additional measures that must be taken to protect against process media.

⚠ WARNING

Personal injury or property damage may result from fire or explosion if natural gas is used as the supply medium and appropriate preventive measures are not taken. Preventive measures may include, but are not limited to, one or more of the following: Remote venting of the unit, re-evaluating the hazardous area classification, ensuring adequate ventilation, and the removal of any ignition sources.

3582i does not meet third party approvals for use with natural gas as the supply medium. Use of natural gas as the supply medium can result in personal injury or property damage from fire or explosion.

CAUTION

Do not use sealing tape on pneumatic connections. This instrument contains small passages that may become obstructed by detached sealing tape. Thread sealant paste should be used to seal and lubricate pneumatic threaded connections.

Note

All valve positioners are shipped with foam rubber packing material inside the case. Remove the cover (key 33, figure 20) and the packing material before attempting to operate the unit. Make sure all vent openings are clear before installation of the unit and that they remain clear during use.

Typically, the positioner is ordered with the actuator. If so, the factory mounts the valve positioner and connects the valve positioner output to the actuator. If a Fisher 67CFR filter-regulator is specified, it may be integrally mounted to the valve positioner, except for the 3582NS positioner. For the 3582NS, the 67CFR is separately mounted, not integrally mounted to the positioner.

Note

In some cases, alignment and calibration of the valve positioner at the factory may not be possible, and field alignment and calibration is required. Before putting the valve positioner into service, check the operation of the unit to be sure it is calibrated. If the valve positioner requires alignment or calibration, refer to the appropriate calibration instructions in this manual.

If the valve positioner is ordered separately, disconnected, or removed from the actuator, refer to the appropriate sections of this manual for installation information.

Hazardous Area Classifications and Special Instructions for “Safe Use” and Installation in Hazardous Locations for 582i Electro-Pneumatic Converter

Refer to the following instruction manual supplements for approval information.

- CSA Hazardous Area Approvals - Fisher 582i Electro-Pneumatic Converter ([D104319X012](#))
- FM Hazardous Area Approvals - Fisher 582i Electro-Pneumatic Converter ([D104320X012](#))
- ATEX Hazardous Area Approvals - Fisher 582i Electro-Pneumatic Converter ([D104321X012](#))
- IECEx Hazardous Area Approvals - Fisher 582i Electro-Pneumatic Converter ([D104322X012](#))

All documents are available from your [Emerson sales office](#) or Fisher.com. Contact your Emerson sales office for all other approval/certification information.

Mounting

Key numbers used in this procedure are shown in figure 2 except where indicated.

- Figure 2 shows the various mounting parts required for mounting on Fisher actuators. Mounting parts for actuators that require spacers have the spacers (key 50) included. 657 and 667 actuators, sizes 70 through 100, with or without a side-mounted handwheel, use spacers (keys 97 and 102) between the stem connector and the connector arm (key 48). On all other actuators that use spacers, place the spacers (key 50) between the mounting plate (key 63) and the actuator mounting boss.

When mounting the valve positioner on an actuator by another manufacturer, provide spacers, if necessary, by cutting sections from 1/2 or 3/8-inch pipe so that the "X" dimension matches the value given in figure 3.

Figure 2. Mounting Assembly

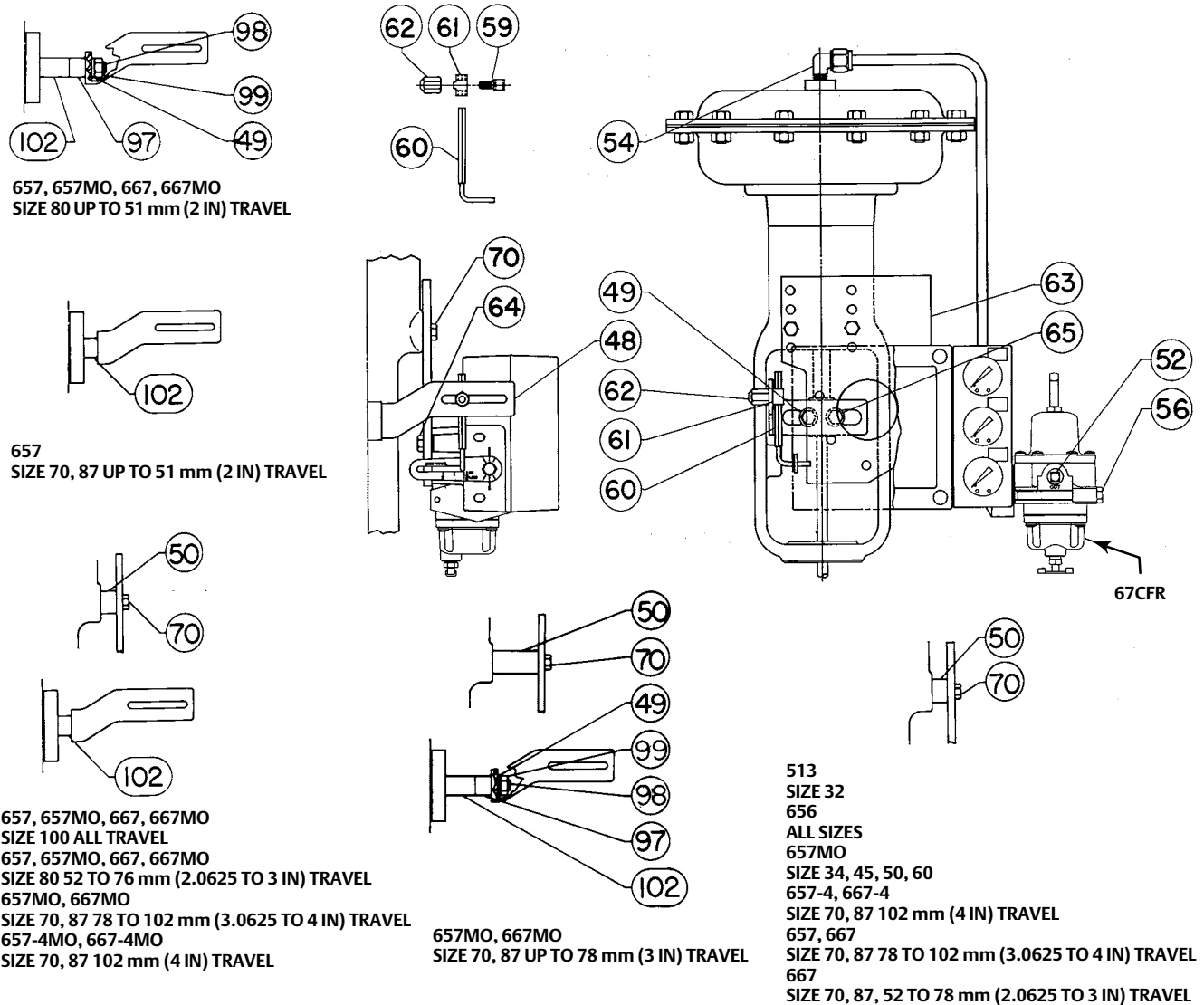

NOTE:
KEY 55 (TUBING CONNECTOR) NOT SHOWN
41B8569-D SHT 1 AND 2

2. As shown in figures 2 and 4 attach the connector arm (key 48) to the stem connector so that the connector arm extends through the yoke legs on the side of the lower mounting boss.
3. Attach the valve positioner to the mounting plate (key 63) using the holes shown in figure 5.
4. Mount the 67CFR regulator:
 - 3582 valve positioners (except 3582NS), mount the regulator on the integral boss on the bypass block.
 - 3582NS valve positioners, use the mounting plate with provision for separately mounting the 67CFR regulator. Separately mount the positioner and the regulator on the mounting plate.
 - 3582i valve positioners, mount the regulator on the integral boss that is part of the 582i converter housing.
5. As shown in figure 5, the mounting bracket has four sets of holes for mounting the assembly to the actuator. Refer to table 3 to determine which set of mounting holes to use, then attach the assembly to the lower mounting pad on the actuator.

CAUTION

To avoid equipment damage, be certain the connector arm clears the valve positioner case as the actuator moves through its complete stroke.

6. Position the actuator to its mid-travel position using a handwheel or manual loading regulator.
7. Slip the round end of the travel pin (key 60) into the rotary shaft arm (key 2) slot as shown in figure 4.
8. Slide the square end of the travel pin into the pin holder and pin lock (keys 61 and 59). Place the pin lock and holder into the slot in the connector arm (key 48). Screw the cap nut (key 62) onto the pin lock (key 59), but do not tighten.
9. With the actuator at its mid-travel position, lift the rotary shaft arm so that the 0-degree index marks on the rotary shaft arm are aligned with the case index marks as shown in figure 6.

CAUTION

Never set the travel pin at a setting that is less than the actual actuator stroke. Setting the travel pin at a setting that is less than the actual actuator stroke will cause the cam to rotate more than 60 degrees, causing damage to the cam or other parts.

10. Position the travel pin so that it is perpendicular to the connector arm and aligns with the correct actuator stem travel index on the rotary shaft arm. Tighten the cap nut to a torque of 10.6 N•m (94 in•lbf) (key 62 in figure 4).
11. Check the travel pin setting using the following procedures:
 - For standard travel pin setting (that is, with the travel pin setting equal to total actuator travel). Stroke the actuator to each end of its travel. At each end of travel, the 30-degree index marks on the rotary shaft arm should align with the case index marks. If the index marks are not in line, loosen the cap nut (key 62) and slide the travel pin (key 60) in the rotary shaft arm slot until the 30-degree index marks align with the case index marks. Be sure the travel pin remains perpendicular to the connector arm. After making this adjustment, tighten the cap nut and re-check the arm at the mid-travel position. If the 0-degree index marks do not align, repeat this procedure.
 - For special travel pin setting (that is, with the travel pin setting greater than total actuator travel). Check the index marks using a procedure similar to the standard settings procedure. The arm will not rotate a full 60 degrees as the actuator is stroked, and the 30-degree index marks on the cam will be short of aligning with the

case index marks. If necessary, adjust the travel pin position so that the 30-degree marks are the same distance from the respective case index mark at each end of actuator travel.

Figure 3. Spacing for Mounting on Other than Fisher Actuators

STEM TRAVEL	X		
	9.5 mm (0.375 Inch) Stem	12.7 mm (0.5 Inch) Stem	19.1 mm (0.75 Inch) Stem
Millimeters			
29 or less	81	87	100
38	90	97	109
51	102	108	121
64	113	119	132
76	124	130	143
89	135	141	154
102	146	152	165
Inches			
1.125 or less	3.19	3.44	3.94
1.5	3.56	3.81	4.31
2	4.00	4.25	4.75
2.5	4.44	4.69	5.19
3	4.88	5.12	5.62
3.5	5.31	5.56	6.06
4	5.75	6.00	6.50

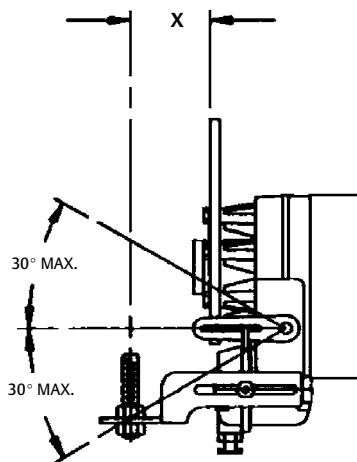

1186520-F

Figure 4. Isometric View Showing Motion Feedback Arrangement and Typical Stem Connection

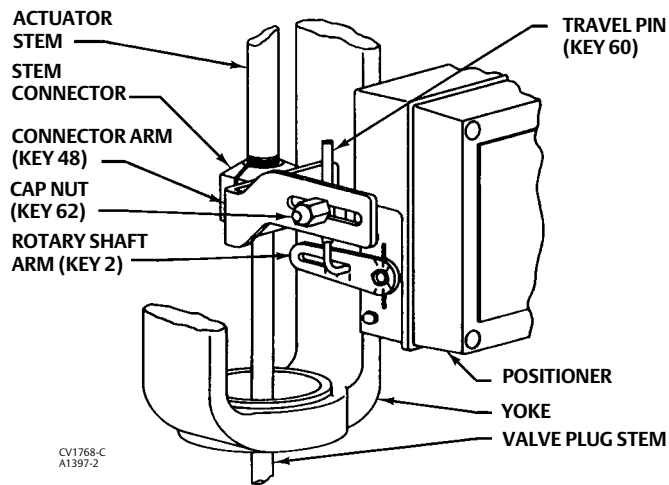

Figure 5. Mounting Plates Used with Fisher 3582 Valve Positioners

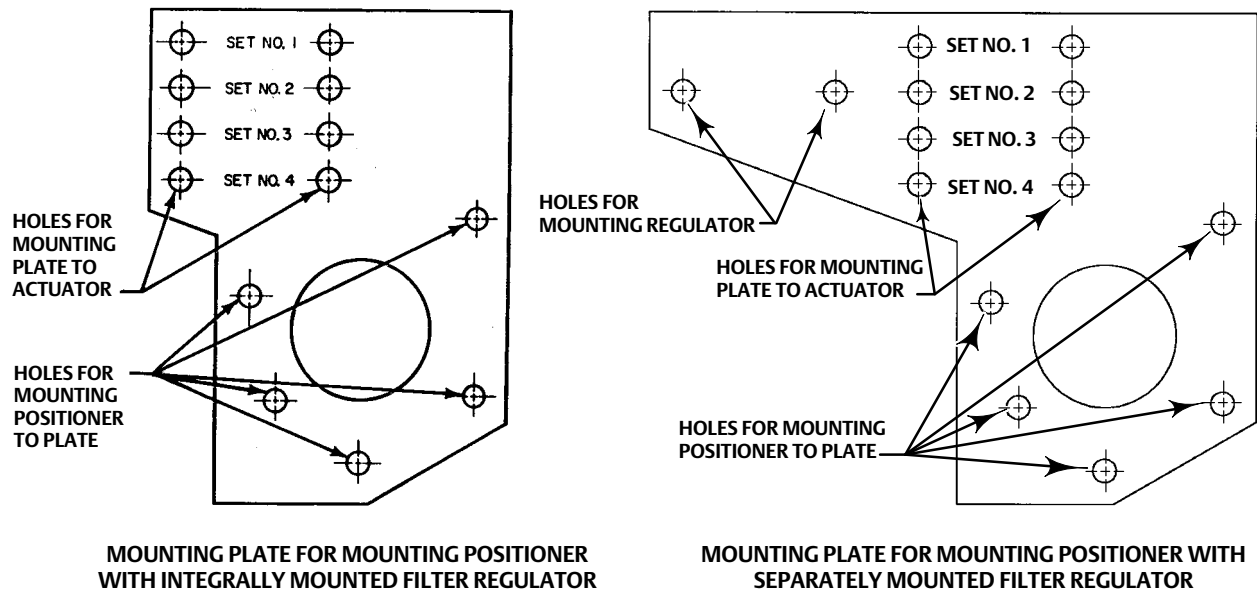
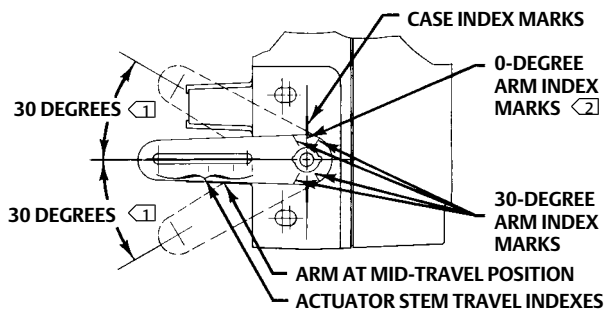

Figure 6. Rotary Shaft Arm and Case Index Marks



NOTES:
 ① MAXIMUM ROTATION FROM MID-TRAVEL POSITION.
 ② ALIGN INDEX MARKS AS SHOWN FOR MID-TRAVEL POSITION.

70CA0750-C
 A2452-2

Table 3. Fisher 3582 Mounting Information

ACTUATOR		MAXIMUM TRAVEL		MOUNTING HOLES SET NO.(1)	TRAVEL PIN POSITION(2)	ACTUATOR		MAXIMUM TRAVEL		MOUNTING HOLES SET NO.(1)		TRAVEL PIN POSITION(2)	
Type	Size	mm	Inch			Type	Size	mm	Inch	657	667		
513 & 513R	20	19	0.75	2	Normal	657 & 667 Without Side-Mounted Handwheel	30	19	0.75	3	4	Normal	
	32	19	0.75	2			34	19	1.125	3	2		Normal
656	30	51	2	4	Inverted		40	38	1.5	2	3		
	40	89	3.5	4	Inverted		45	19	0.75	1	4		
	60	102	4	4	Inverted		45	51	2	1	1	Normal	
	657-4 Without Side-Mounted Handwheel	70	102	4	3		Inverted	50	51	2	1		2
657-4 With Side-Mounted Handwheel		70	102	4	2			Inverted	60	51	2	1	2
	657-8	30	54	2.125	3		Normal		70	51	2	2	1
34		54	2.125	3	Normal			52-76	2.0625-3	3	2	Normal	
40		79	3.125	3				Normal	78-102	3.0625-4	3		1
40		89	3.5	3					Normal	87	51	2	2
46		79	3.125	2			Normal	52-76			2.0625-3	2	2
46		105	4.125	2	Normal	78-102		3.0625-4		3	1	Inverted(4)	
47		79	3.125	2		Normal		100		102	4		4
47		105	4.125	1	Inverted			657 & 667 With Side-Mounted Handwheel	34	19	0.75	2	2
60	105	4.125	4	Inverted			40		38	1.5	1	2	
70	105	4.125	2				Inverted		45	51	2	1	4
667-4 Without Side-Mounted Handwheel	70	102	4			1			Normal	50	51	2	4
	87	102	4		1	Normal		60		51	2	3	1
667-4 Without Side-Mounted Handwheel	70	102	4	1	Normal			70	102	4	2	2	Inverted
						80	76	3	2	2			
						87	76	3	2	2			
						78-102	3.0625-4	2	1				

1. The indicated set number should be considered a reference point only, due to the variables related to making up the stem connection.
 2. Normal position is shown in figure 4.
 3. Travel pin position for 657 is normal.
 4. Travel pin position for 667 is normal.

Changing Cam Position

Refer to figure 20 for a typical cam illustration and key number locations.

Note

The small arrow on the cam must point in the direction of stem movement with increasing actuator diaphragm pressure.

If the arrow is pointing in the wrong direction, use the following procedure to remove, reverse, and re-install the cam.

When mounting a valve positioner check to see if the correct cam (key 4) and cam position has been selected. To change the cam or cam position, unhook the extension spring (key 38), and remove the cam bolt and locking nut (keys 6 and 45). Remove the cam and spring retainer bracket (key 43).

To install the cam, screw the locking nut all the way onto the cam bolt. Attach the cam and spring retainer bracket to the shaft assembly with the cam bolt. Tighten the bolt to secure the cam. Then, tighten the locking nut against the spring retainer bracket. Hook the spring into the spring retainer bracket.

Details on cam characteristics can be found on page 20 in the cam information portion of the operating information section.

Pressure Connections

⚠ WARNING

Valve positioners are capable of providing full supply pressure to connected equipment. To avoid personal injury or equipment damage caused by parts bursting from system overpressure, make sure the supply pressure never exceeds the maximum safe working pressure of any connected equipment.

CAUTION

Do not use sealing tape on pneumatic connections. This instrument contains small passages that may become obstructed by detached sealing tape. Thread sealant paste should be used to seal and lubricate pneumatic threaded connections.

Pressure connections are shown in figure 7. All pressure connections are 1/4 NPT internal. Use 3/8-inch tubing for all pressure connections. After making pressure connections, turn on the supply pressure and check all connections for leaks.

Supply Connection

⚠ WARNING

Personal injury or property damage may occur from an uncontrolled process if the supply medium is not clean, dry, oil-free air, and noncorrosive gas. While use and regular maintenance of a filter that removes particles larger than 40 micrometers in diameter will suffice in most applications, check with an Emerson field office and industry instrument air quality standards for use with corrosive air or if you are unsure about the proper amount or method of air filtration or filter maintenance.

3582i does not meet third party approvals for use with natural gas as the supply medium. Use of natural gas as the supply medium can result in personal injury or property damage from fire or explosion.

Figure 7. Typical Dimensions and Connections

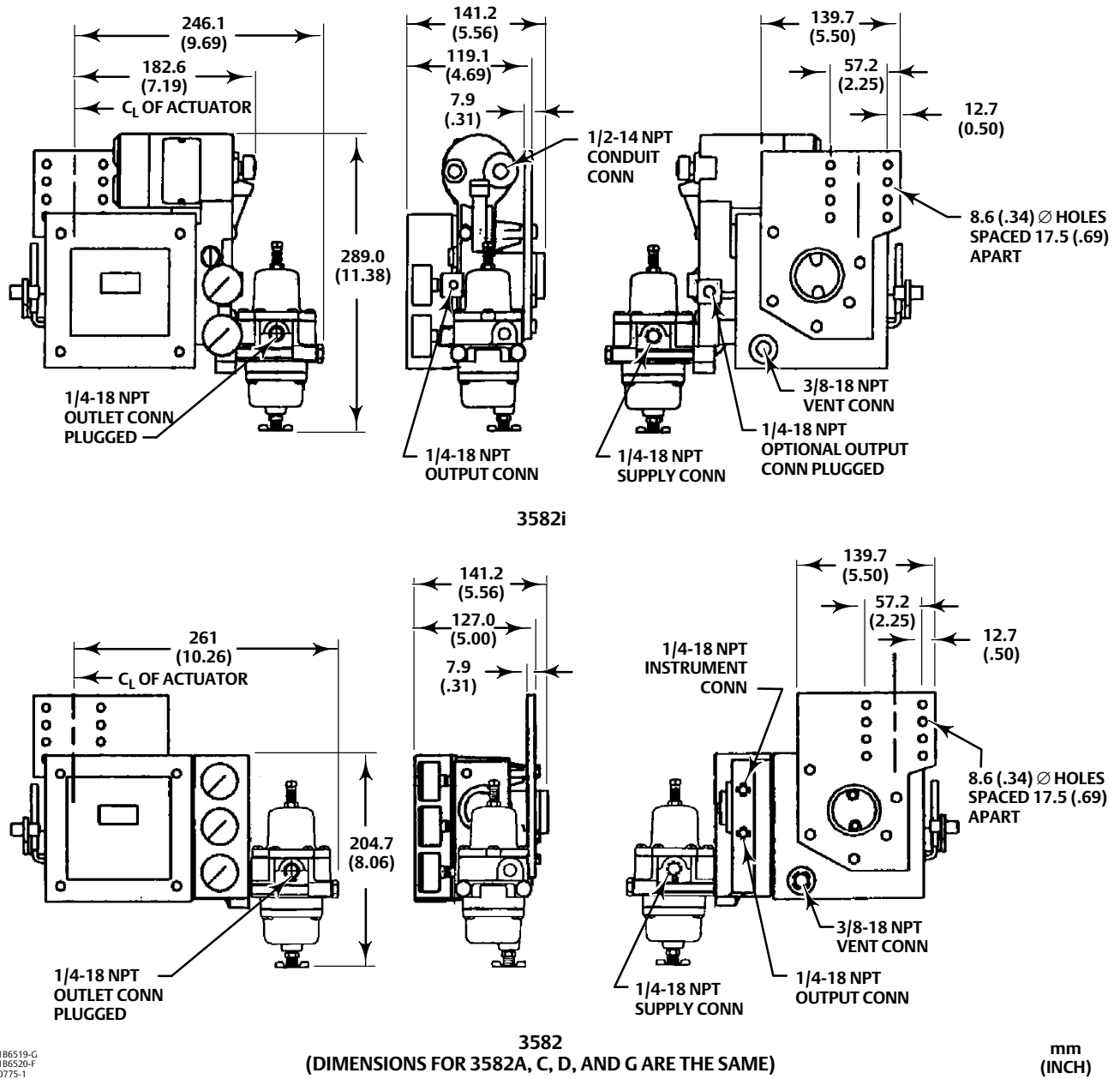

1186519-C
1186520-F
C0775-1

CAUTION

Use a clean, dry, oil-free air supply with instruments containing EPDM components. EPDM is subject to degradation when exposed to petroleum-based lubricants.

Supply pressure must be clean, dry, oil-free air or noncorrosive gas. Use a 67CFR filter regulator with standard 5 micrometer filter, or equivalent, to filter and regulate supply air. Except for the 3582NS, the filter regulator can be

mounted on the positioner. For the 3582NS the regulator can be mounted on the mounting plate with the positioner but not on the positioner. The supply pressure should be high enough to permit setting the regulator 0.3 bar (5 psi) above the upper limit of the appropriate pressure range, for example: 1.4 bar (20 psig) for a 0.2 to 1.0 bar (3 to 15 psig) range. However, do not exceed the maximum allowable supply pressure of 3.4 bar (50 psig) nor the pressure rating of any connected equipment.

Connect the nearest suitable supply source to the 1/4 NPT IN connection on the filter regulator (if furnished) or to the 1/4 NPT SUPPLY connection on the positioner block assembly.

Output Connection

A factory mounted valve positioner has the valve positioner output piped to the supply connection on the actuator. If mounting the valve positioner in the field, connect 3/8-inch tubing between the 1/4 NPT valve positioner connection marked OUTPUT and the actuator supply pressure connection.

Instrument Connection

For a 3582 pneumatic valve positioner connect 3/8-inch tubing from the control device to the 1/4 NPT INSTRUMENT connection. If the control device is mounted on the control valve assembly by the factory, this connection is made.

The 3582i electro-pneumatic valve positioner requires a 4-20 milliampere DC current input signal from the control device. A 1/2 NPT conduit connection is provided for properly wiring electrical installations. For more information, see the electrical connections section.

Diagnostic Connections

To support diagnostic testing of valve/actuator/positioner/accessory packages, special connectors and hardware are available. The hardware used includes 1/8 NPT connector bodies and body protectors. If the diagnostic connectors are ordered for a positioner with gauges, 1/8-inch stems are also included.

Install the connectors on the 3582 block assembly or 582i housing as shown in figure 8. Before installing the connectors on the positioner, apply sealant to the threads. Sealant is provided with the diagnostic connections and hardware.

Figure 8. Diagnostic Connections

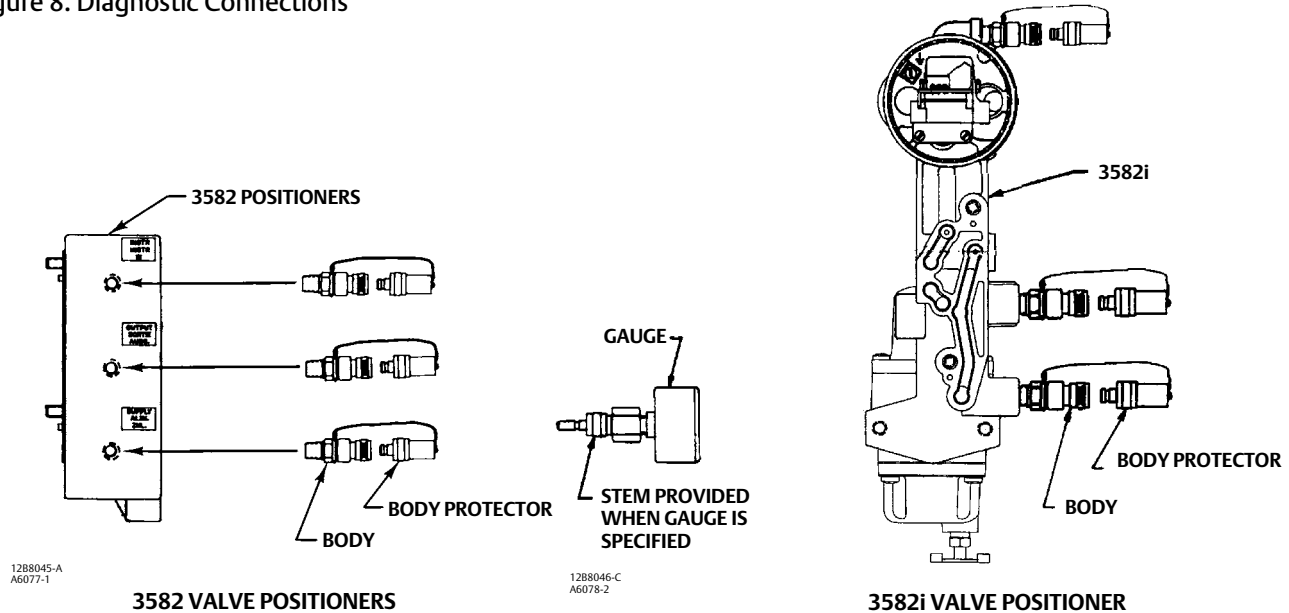

Vent

⚠ WARNING

Personal injury or property damage could result from fire or explosion of accumulated gas if a flammable gas is used as the supply pressure medium and the positioner/actuator is in an enclosed area. The positioner/actuator assembly does not form a gas-tight seal, and when the assembly is enclosed, a remote vent line, adequate ventilation, and necessary safety measures should be used. For leakage rates, see the Maximum Steady-State Air Consumption specification. A remote vent pipe alone cannot be relied upon to remove all hazardous gas. Vent line piping should comply with local and regional codes and should be as short as possible with adequate inside diameter and few bends to reduce case pressure buildup.

⚠ WARNING

3582i does not meet third party approvals for use with natural gas as the supply medium. Use of natural gas as the supply medium can result in personal injury or property damage from fire or explosion.

CAUTION

When installing a remote vent pipe, take care not to overtighten the pipe in the vent connection. Excessive torque will damage the threads in the connection.

The vent opening at the back of the case marked VENT should be left open to prevent pressure buildup inside the case and to provide a drain hole for any moisture that might collect inside the case. The perforated section of the nameplate normally covers this opening to prevent blockage from debris or insects. Also, ensure the exhaust holes in the relay (key 32 in figure 20) are kept open.

If a remote vent is required, the vent line must be as short as possible with a minimum number of bends and elbows. The vent connection is 3/8 NPT internal. Use 3/8-inch or larger tubing to provide a remote vent. The 582i has a 1/4 NPT internal vent connection. Use optional remote vent 83L relay for remote vent applications.

Electrical Connections for 3582i Valve Positioner

⚠ WARNING

For explosion-proof applications, disconnect power before removing the converter housing cap.

For Class I, Division 1 explosion-proof applications, install rigid metal conduit and a conduit seal no more than 457 mm (18 inches) from the converter. Personal injury or property damage might result from explosion if the seal is not installed.

For intrinsically safe installations, refer to the loop schematics included in the appropriate Hazardous Area Approval Supplement (CSA, [D104319X012](#) or FM, [D104320X012](#)), factory drawings, or to instructions provided by the barrier manufacturer for proper wiring and installation.

Select wiring and/or cable glands that are rated for the environment of use (such as hazardous area, ingress protection and temperature). Failure to use properly rated wiring and/or cable glands can result in personal injury or property damage from fire or explosion.

Wiring connections must be in accordance with local, regional, and national codes for any given hazardous area approval. Failure to follow the local, regional, and national codes could result in personal injury or property damage from fire or explosion.

Use the 1/2-14 NPT conduit connection on the 582i converter housing for installation of field wiring. For Class I, Division I explosion-proof applications, install rigid metal conduit and a seal no more than 457 mm (18 inches) from the converter. Also, install conduit according to local and national electrical codes which apply to the application.

Refer to figures 9, 10 and 11 when connecting field wiring from the control device to the converter. Connect the positive wire from the control device to the converter positive (+) terminal, and the negative wire from the control device to the converter negative (-) terminal. Do not overtighten the terminal screws. Maximum torque is 0.45 N•m (4 lbf•in.). Connect the converter grounding terminal to an earth ground.

Figure 9. Typical Field Wiring Diagram

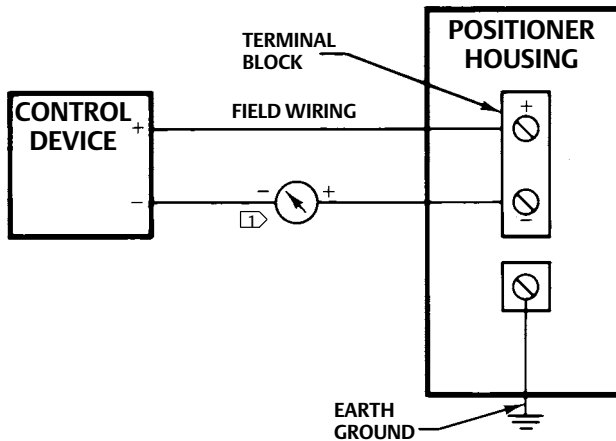

NOTES:
 □▷ FOR TROUBLESHOOTING OR MONITORING OPERATION, AN INDICATING DEVICE CAN BE A VOLTMETER ACROSS A 250 OHM RESISTOR OR A CURRENT METER.

A3875

Figure 10. Input Equivalent Circuit for Fisher 582i Converter

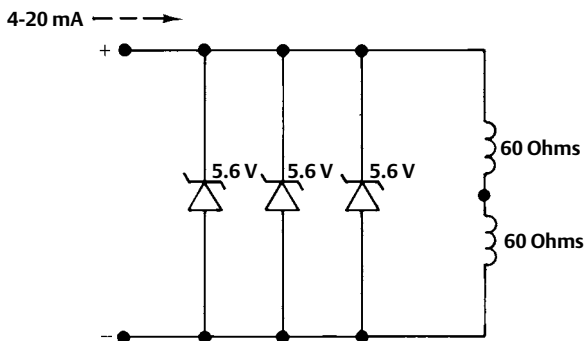

2182335-D
 A6012

Figure 11. Wiring Connections for Fisher 582i Converter

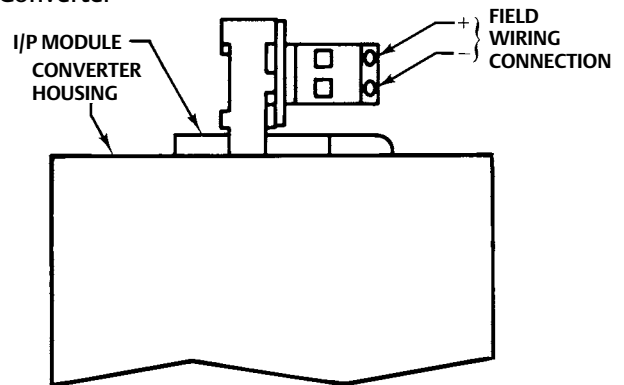

A7140

582i Converter Installation

Note

Contact your [Emerson sales office](#) for application information before upgrading an existing 3582 valve positioner by field installation of a 582i electro-pneumatic converter.

⚠ WARNING

Avoid personal injury from sudden release of process pressure. Before mounting the 582i converter:

- **Always wear protective clothing, gloves, and eyewear when performing any maintenance operations.**
 - **Do not remove the actuator from the valve while the valve is still pressurized.**
 - **Disconnect any operating lines providing air pressure or a control signal to the actuator. Be sure the actuator cannot suddenly open or close the valve.**
 - **Use bypass valves or completely shut off the process to isolate the valve from process pressure. Relieve process pressure on both sides of the valve.**
 - **Vent actuator loading pressure.**
 - **Use lock-out procedures to be sure that the above measures stay in effect while you work on the equipment.**
 - **Do not open when an explosive dust atmosphere is present.**
 - **Check with your process or safety engineer for any additional measures that must be taken to protect against process media.**
-

Note

Before planning to retrofit an installed 3582 positioner, refer to the positioner mounting plate illustrations shown in figure 5. Mounting plates with a three-hole mounting pattern (positioner to mounting plate) cannot support a 582i converter. Do not attempt to mount a 582i converter on an existing 3582 positioner which has a three-hole mounting pattern.

Isolate the control valve from the line pressure, and release pressure from both sides of the valve body. Use lock-out procedures to be sure that the above measures stay in effect while you work on the equipment.

If a 3582 pneumatic valve positioner has previously been installed using a mounting plate with a five-hole mounting pattern (positioner to mounting plate), either at the factory or in the field, it can be upgraded to a 3582i electro-pneumatic valve positioner by installation of a 582i converter. To install a 582i converter, refer to the following instructions.

Note

Inspect the existing valve positioner to determine the input signal range. If the input signal range is not 0.2 to 1.0 bar (3 to 15 psig), refer to the appropriate sections of this manual describing input signal ranges and how to change the range spring.

1. Inspect the positioner mounting plate. Be certain that five screws fasten the positioner to the mounting plate. Two additional screws fasten the plate to the actuator.

When the positioner is correctly attached to the mounting plate, proceed with the installation by taking the control valve/actuator/positioner package out of service.

2. Properly vent the actuator loading pressure and the supply pressure. Disconnect the pressure tubing connections to the valve positioner.
3. Remove the two screws (key 105 in figures 23 or 24) holding the bypass block (key 34A in figures 23 or 24) to the valve positioner case and remove the bypass block. Save the screws to reattach the 582i converter.
4. Remove and discard the existing gasket (key 104 in figures 23 or 24) between the bypass block and valve positioner case.
5. Unpack the 582i converter to be installed.
6. Position the new gasket on the 582i converter as shown in figure 25. Insert the existing screws (key 105 in figures 23 or 24) through the appropriate holes in the 582i converter housing and new gasket.
7. Mate the converter and new gasket to the side of the valve positioner case using the alignment pins on the converter housing.
8. Tighten the screws.
9. Reconnect the pressure connections according to the instructions given in the pressure connections section of this manual.
10. Make the electrical connections according to the instructions given in the electrical connections section of this manual.
11. Complete the standard calibration procedure described in the calibration section of this manual.
12. Return the control valve package to service.

Operating Information

Instructions for setting the zero and span are found in the calibration section.

Valve Positioner Cam Information

Note

The small arrow on the valve positioner cam must point in the direction of stem movement with increasing actuator diaphragm pressure. If the arrow is pointing in the wrong direction, remove, reverse, and re-install the cam. Refer to the Changing Cam Position section of this manual.

Refer to figure 20 for key number locations. Unhook the spring (key 38), and remove the cam bolt and locking nut (keys 6 and 45). Remove the cam (key 4) and spring retainer bracket (key 43). To install the cam, screw the locking nut all the way onto the cam bolt. Attach the cam and spring retainer bracket with the cam bolt. Tighten the bolt to secure the cam. Then, tighten the locking nut against the spring retainer bracket. Hook the spring into the spring retainer bracket.

When shipped from the factory, 3582 valve positioners and the 3582i valve positioner have a linear cam, Cam A, installed in the operating position. Two characterized cams, Cams B and C, are available. These characterized cams may be used to modify the valve flow characteristics.

Figure 12 shows resultant stem travel due to an incremental instrument pressure change for each cam. In figure 12, the curves are based on 60 degrees cam rotation for 100 percent stem travel. At 50 percent of the input signal span,

for example, the stem will travel 50 percent with cam A, 68 percent with cam B, and 32 percent with cam C. Figure 13 shows how the flow characteristics change when using the cams with a valve that has equal percentage characteristics. Figure 14 shows how the flow characteristics change when using the cams with a valve that has linear characteristics.

Figure 12. Cam Characteristic Curves

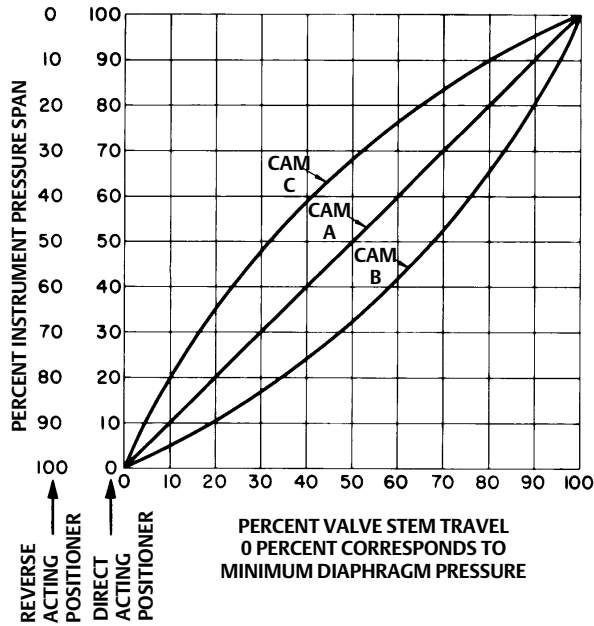

CK4832-A

Figure 13. Flow Characteristics with Different Cams and Equal Percentage Valve Plug

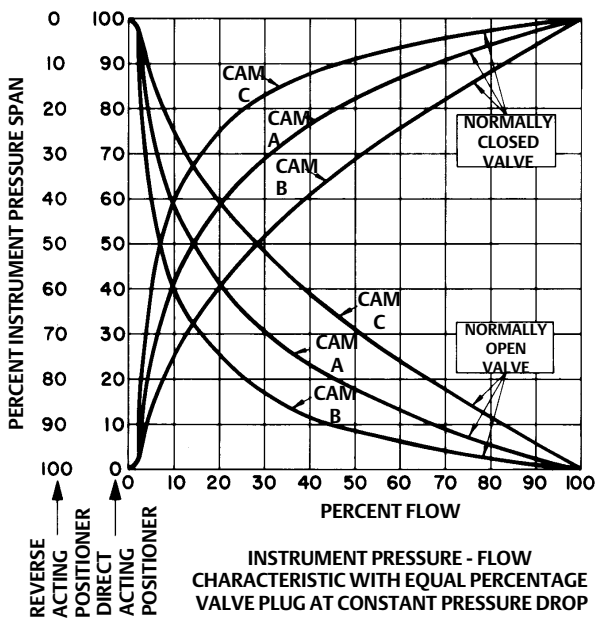

CK4835-A

Figure 14. Flow Characteristics with Different Cams and Linear Valve Plug

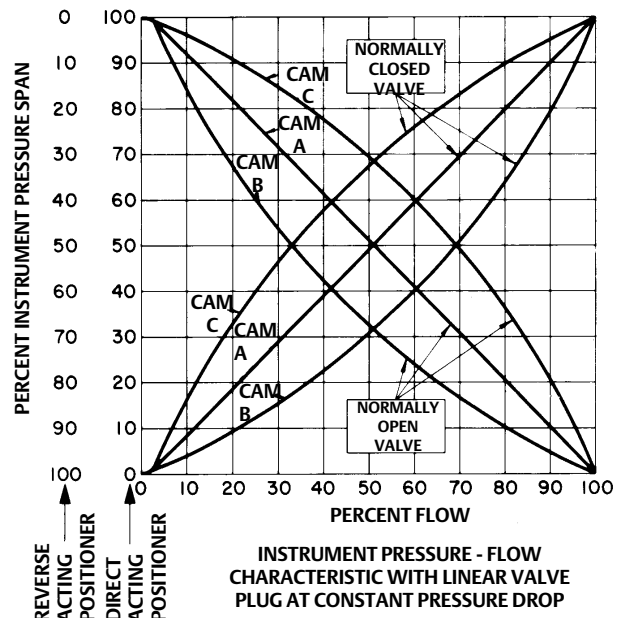

CK4833-A

When cam A is the operating cam, there is a linear relationship between an incremental instrument pressure change and the resultant valve stem travel. The flow characteristic is that of the control valve. Installing either cam B or C as the operating cam changes the relationship between the incremental instrument pressure change and valve stem travel, thereby modifying the valve flow characteristic.

Valve Positioner Bypass Operation

3582 and 3582D valve positioners, and 3582NS positioners with bypass, are supplied with a bypass assembly. A handle on the bypass assembly permits selecting positioner or bypass operation. Refer to figure 23 for key number locations.

CAUTION

Do not use bypass when the valve positioner is reverse-acting or is in split-range operation. In these cases, bypassing the valve positioner sends the input signal directly to the actuator. Such a change will affect the desired operation and possibly upset the system. Use bypass only when the input signal range is the same as the valve positioner output range required for normal actuator operation.

Labels on the bypass block (key 34A) and a pointer on the bypass handle (key 34D) indicate if the input signal from the instrument goes to the positioner or directly to the control valve actuator. Push the bypass handle toward the back of the positioner to move the pointer over the word POSITIONER. With the bypass handle in this position, the input signal goes to the valve positioner bellows and the output pressure of the valve positioner goes to the actuator. Pull the bypass handle forward to move the pointer over the word BYPASS. In this position, the input signal goes directly to the actuator.

Note

A difference between the input signal pressure and the valve positioner output pressure could cause a transient bump in the controlled system when the bypass handle is moved to BYPASS.

With a reverse-acting or split-range valve positioner, the bypass handle may be locked in the POSITIONER position so that bypass cannot be used. To lock the bypass handle in the POSITIONER position, first shut off the instrument and supply pressure to the valve positioner. Then, remove the hex head shoulder screw from the center of the handle. Remove the handle and rotate it 180 degrees and re-install it with the handle between the two lugs cast on the bypass block. Replace the shoulder screw.

Input Signal Ranges

Standard input signal ranges for valve positioners are shown in table 4. Changing from one standard range to another requires changing the range spring. To change the range spring, refer to the instructions for changing the range spring in the maintenance section of this manual. Split-range operation of 3582 valve positioners or the 3582i valve positioner normally does not require changing the spring. Refer to the section below for split-range information.

Table 4. Standard Instrument Input Signals and Range Springs

INSTRUMENT INPUT SIGNAL RANGE	STANDARD SPAN	ALLOWABLE INPUT SIGNAL ⁽¹⁾		RANGE SPRING COLOR
		Minimum	Maximum	
0.2-1.0 bar (3-15 psig)	0.8 bar (12 psig)	0.07 bar (1 psig)	1.4 bar (21 psig)	Silver
4-20 mA ⁽²⁾	16 mA	2 mA	22 mA	
0.4-2.0 bar (6-30 psig)	1.6 bar (24 psig)	0.07 bar (1 psig)	2.4 bar (35 psig)	Red

1. Minimum and maximum allowable input signals ensure functional operation.

2. For 3582i only.

Valve Positioner Split-Range Operation

3582 valve positioners and the 3582i valve positioner are suitable for split-range operations. In split-range operation, the input signal, either pneumatic or DC current, from a single control device is split between two or more control valves. No additional parts are required to use an existing valve positioner for split-range operation.

Table 5 shows some typical split-ranges for the valve positioners.

Table 5. Split-Range Capabilities

3582 POSITIONERS				
Split	0.2 to 1.0 Bar or 3 to 15 Psig Input Signal		0.4 to 2.0 Bar or 6 to 30 Psig Input Signal	
	Bar	Psig	Bar	Psig
Two-way	0.2 to 0.6 0.6 to 1.0	3 to 9 9 to 15	0.4 to 1.2 1.2 to 2.0	6 to 18 18 to 30
Three-way	0.2 to 0.5 0.5 to 0.7 0.7 to 1.0	3 to 7 7 to 11 11 to 15	0.4 to 0.9 0.9 to 1.5 1.5 to 2.0	6 to 14 14 to 22 22 to 30
3582i POSITIONER				
Split	4-20 Milliampere Input Signal			
Two-way	4 to 12 12 to 20			
Three-way	4 to 9.3 9.3 to 14.7 14.7 to 20			

To change to split-range operation, perform the beam alignment procedures then perform the calibration procedure using the desired split range inputs that result in full valve travel. For example, for a 3582 positioner with a 0.2 to 1.0 bar (3 to 15 psig) input signal range in a two-way split, a 0.6 bar (9 psig) input signal should completely stroke the valve for a 0.2 to 0.6 bar (3 to 9 psig) signal range.

Note

The flapper must approach the nozzle squarely at the midpoint value of the input signal range for proper operation.

On some applications where the input signal span is comparatively small (as found with split-range applications), the nozzle adjustment may not be enough to set the proper starting point. Also, some difficulty may be experienced in keeping a valve positioner from unloading when the input signal continues to increase above the split-range.

For example, for a 0.2 to 0.6 bar (3 to 9 psig) input signal range, the input signal could increase to 1.0 bar (15 psig). Continued bellows travel due to the increased input signal over the split-range would drive the flapper into the nozzle. The impact could possibly cause misalignment between the flapper and nozzle. Such a misalignment, in turn, could affect split-range calibration.

In these cases, adjust the flapper assembly screw in addition to the nozzle adjustment to obtain satisfactory results.

Note

3582 valve positioners require a relatively small percentage of the instrument pressure span to obtain full valve travel. With the travel pin set to equal the valve travel, the input signal change required to fully stroke the valve can be reduced to 33 percent of normal input signal change. With the travel pin set to a value greater than the valve travel, the input signal change required to fully stroke the valve can be reduced to a minimum of 20 percent of normal input signal change.

Changing Valve Positioner Action

Converting a 3582 valve positioner or 3582i valve positioner from direct acting (an increasing input signal, either pneumatic or electrical, increases output pressure) to reverse acting (increasing input signal decreases output

pressure) or vice versa requires no additional parts. The position of the flapper assembly on the beam determines the action. As shown in figure 15, the beam is divided into quadrants. The direct-acting quadrant of the beam is labeled DIRECT and the reverse-acting quadrant is labeled REVERSE. To change the positioner action, simply move the flapper assembly to the opposite quadrant of the beam. Perform the calibration procedures in the valve positioner calibration section.

Figure 15. Partial View for Beam Leveling and Calibration

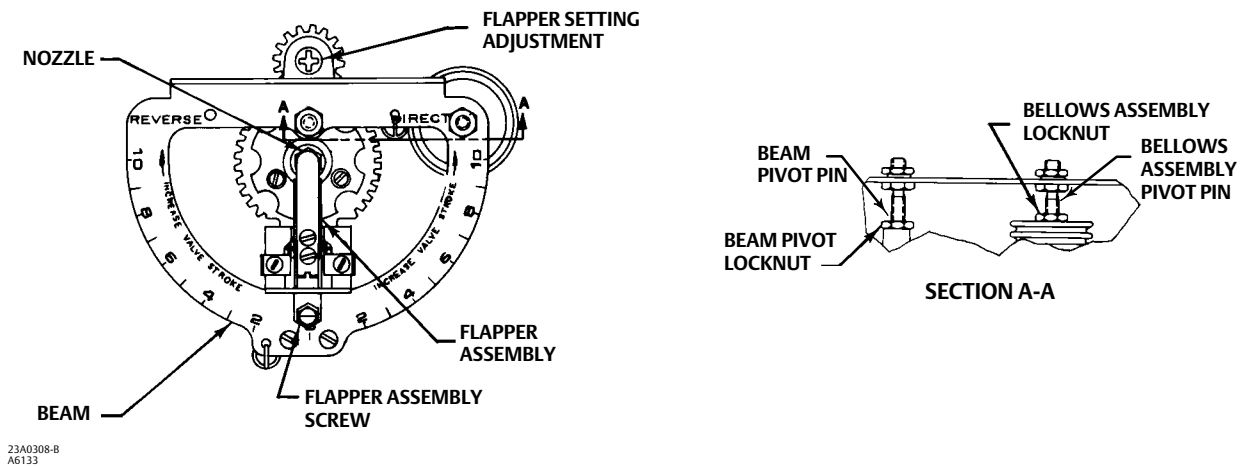

Calibration Of Valve Positioner

The following beam alignment and calibration procedures are applicable for 3582 and 3582i valve positioners.

⚠ WARNING

During calibration the valve may move. To avoid personal injury or property damage caused by the release of pressure or process fluid, provide some temporary means of control for the process.

Beam Alignment

Note

The beam is leveled at the factory prior to shipment. Once the beam is leveled, no additional leveling should be required unless the beam pivot pin or the bellows assembly pivot pin are changed, the bellows assembly or range spring are replaced, or the valve positioner is changed to split range operation.

The purpose of beam alignment is to ensure the correct mechanical position of parts so the valve positioner can be calibrated. Provide the appropriate supply pressure. Also, provide an input signal to the positioner which can be manually set at the midpoint of the desired input signal range.

Refer to figure 15 for parts locations. Refer to figure 20 for key number locations unless otherwise indicated. Position the flapper assembly by hand to different settings on the beam assembly or by using a screwdriver in the slot of the flapper setting adjustment.

To level the beam, proceed as follows:

Note

In the following steps, if the required rotary shaft arm position cannot be attained when adjusting a pivot point, adjust one of the other pivot points slightly. Then, repeat the original pivot adjustment. Continue this process until the required arm position can be attained.

1. Stroke the actuator to its mid-travel position with a handwheel or a manual loader. Refer to figure 4 and 6. Lift the rotary shaft arm (key 2) so that the 0-degree index marks on the rotary shaft arm align with the case index marks as shown in figure 6. Then, position the travel pin (key 60) so that it is perpendicular to the arm and aligns with the appropriate total actuator travel index mark on the rotary shaft arm. Tighten the cap nut (key 62).

Note

Valve stem travels less than 29 mm (1.125 inches) require that the travel pin be set at the 1-1/8 inches travel index mark on the rotary shaft arm.

2. Loosen the nozzle locknut and turn the nozzle clockwise to its lowest position. Then screw the nozzle out (counterclockwise) approximately 4 turns and tighten the locknut.

Note

For proper operation, the flapper must approach the nozzle squarely. Inspect the nozzle/flapper alignment. Be sure the flapper is not loose, bent, or twisted.

3. Remove any loading pressure and/or disengage any handwheel used to position the actuator. Connect the necessary tubing from the valve positioner output to the actuator pressure connection.
4. Connect the input to the valve positioner and set the input signal value at midrange. For example, for a 3582 valve positioner with a 0.2 to 1.0 bar (3 to 15 psig) input signal range, set the input signal at 0.6 bar (9 psig). Then apply supply pressure to the valve positioner.
5. Move the flapper assembly to zero on the beam scale. The 0-degree index marks on the rotary shaft arm should align with the case index marks as shown in figure 16. If not, loosen the flapper assembly screw locknut and adjust the flapper assembly screw until the 0-degree index marks on the rotary shaft arm align with the case index marks. Tighten the locknut.
6. Move the flapper assembly to position 10 on the direct-acting side of the beam scale. The 0-degree index marks on the rotary shaft arm should align with the case index marks as shown in figure 16. If not, loosen the bellows assembly locknut and adjust the bellows pivot pin until the 0-degree index marks on the rotary shaft arm align with the case index marks. Tighten the locknut.
7. Move the flapper assembly to the left to position 10 on the reverse-acting side of the beam. The 0-degree index marks on the rotary shaft arm should align with the case index marks as shown in figure 16. If not, loosen the beam pivot pin locknut and adjust the beam pivot pin until the 0-degree index marks on the rotary shaft arm align with the case index marks. Tighten the locknut.

8. Repeat steps 5, 6, and 7 to optimize alignment. Recheck to make sure the flapper approaches the nozzle squarely. If it does not, adjust the nozzle and re-level the beam. After alignment, the valve positioner is ready for calibration.

Figure 16. Rotary Shaft Arm 0-Degree and Case Index Marks, Location and Alignment

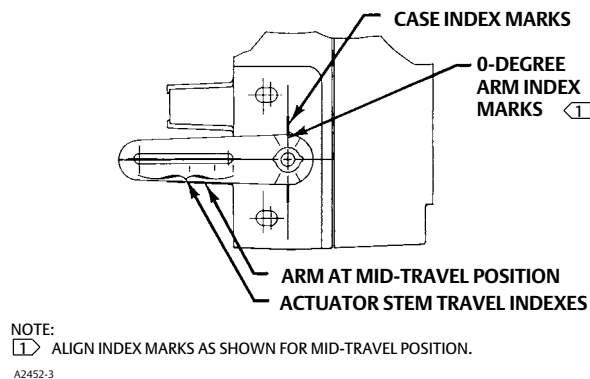

Calibration

⚠ WARNING

During calibration the valve may move. To avoid personal injury or property damage caused by the release of pressure or process fluid, provide some temporary means of control for the process.

1. Shut off the supply pressure to the valve positioner. Connect or reconnect the necessary tubing from the valve positioner output to the actuator supply connection. Connect the input to the valve positioner and set the input signal value at midrange.
2. Move the flapper assembly to approximately position 6 in the proper operating quadrant of the beam (direct or reverse acting), and apply supply pressure to the valve positioner. The 0 degree index marks on the rotary shaft arm should align with the case index marks as shown in figure 16 and the actuator should be at its midtravel position. If not, first check for loose linkage or improper cam installation. A minor nozzle height adjustment might be necessary to make the desired input signal value correspond to the starting point of travel.
3. Apply an input signal equal to the low value of the input signal range. For example, for a 3582 valve positioner with a 0.2 to 1.0 bar (3 to 15 psig) input signal range, set the input signal at 0.2 bar (3 psig). Loosen the nozzle locknut and adjust the nozzle until the actuator moves to the proper end of its travel. Changing the nozzle position is intended only as a means of zero trim adjustment. Whenever nozzle position is changed, the zero reference point is changed.
4. Apply an input signal equal to the high value of the input signal range and observe the actuator stem travel. If the stem travel is short of its expected range, increase the travel by moving the flapper assembly to a higher number on the beam. If the desired stem travel occurs before the input signal reaches the high value of the input signal range, decrease the travel by moving the flapper assembly toward a lower number on the beam.
5. Repeat steps 3 and 4 until the correct travel is achieved. Each time the flapper assembly position is changed in step 4, repeat step 3 to provide proper zero.

Moving the flapper assembly toward zero on the beam scale decreases stem travel. Table 6 lists the minimum stem travel available for different travel pin settings. For example, with a travel pin setting of 2 the minimum stem travel possible, for the full input signal range, would be 11 mm (0.4375 inch).

Note

The positioner will fully vent or pressurize the actuator to supply pressure at the ends of actuator travel when the positioner is calibrated correctly. Failure to properly calibrate the positioner may result in reduced seat loading.

Table 6. Minimum Travel with Given Pin Position

TRAVEL PIN POSITION ALONG ROTARY SHAFT ARM	MINIMUM TRAVEL AVAILABLE	
	mm	Inch
1-1/8	6	0.25
1-1/2	8	0.3125
2	11	0.4375
2-1/2	13	0.5
3	16	0.625
4	22	0.875

Principle of Operation

3582 Valve Positioners

The 3582 (3582, 3582NS and 3582A, C, D, and G pneumatic valve positioners) accepts a pneumatic input signal from a control device. Figure 17 is an operational schematic for a direct-acting pneumatic valve positioner.

As shown in figure 17, in a diaphragm-actuated, sliding stem control valve package with a 3582 valve positioner, supply pressure is connected to the 83L relay. A fixed restriction in the relay limits flow to the nozzle so that when the flapper is not restricting the nozzle, air can bleed out faster than it is being supplied.

The input signal from the control device is connected to the bellows. When the input signal increases, the bellows expands and moves the beam. The beam pivots about the input axis moving the flapper closer to the nozzle. The nozzle pressure increases and, through relay action, increases the output pressure to the actuator. The increased output pressure to the actuator causes the actuator stem to move downward. Stem movement is fed back to the beam by means of a cam. As the cam rotates, the beam pivots about the feedback axis to move the flapper slightly away from the nozzle. The nozzle pressure decreases and reduces the output pressure to the actuator. Stem movement continues, backing the flapper away from the nozzle, until equilibrium is reached.

When the input signal decreases, the bellows contracts (aided by an internal range spring) and the beam pivots about the input axis to move the flapper away from the nozzle. Nozzle pressure decreases and the relay permits the release of diaphragm casing pressure to atmosphere. The actuator stem moves upward. Through the cam, stem movement is fed back to the beam to reposition the flapper closer to the nozzle. When equilibrium conditions are obtained, stem movement stops and the flapper is positioned to prevent any further decrease in diaphragm case pressure.

The principle of operation for reverse acting units is similar except that as the input signal increases, the diaphragm casing pressure is decreased. Conversely, a decreasing input signal causes an increase in the pressure to the diaphragm casing.

Figure 17. Schematic Illustration of Fisher 3582 Positioner

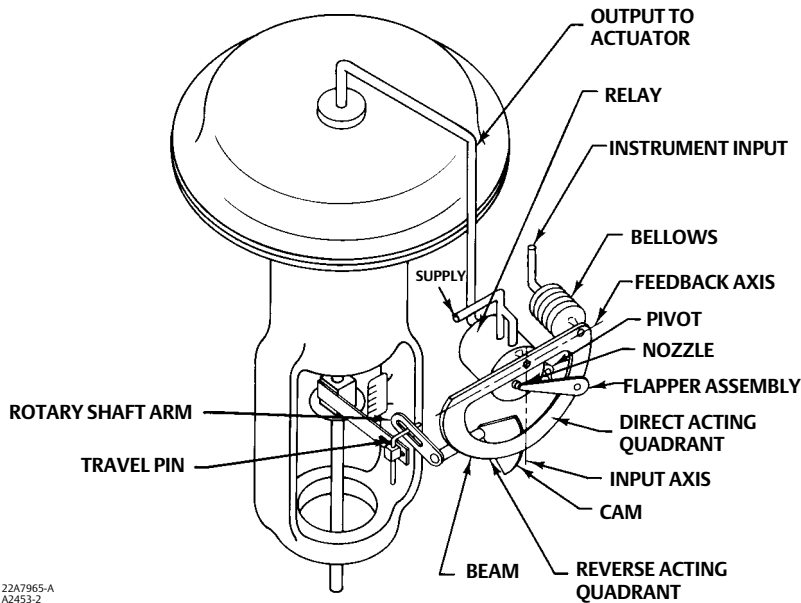

22A7965-A
A2453-2

3582i Valve Positioner

As shown in figure 18, the 3582i electro-pneumatic valve positioner has a 582i electro-pneumatic converter attached to the valve positioner. The 582i contains an I/P module which provides a pneumatic output proportional to a DC current input signal. The DC current input operates coils in a force balanced beam system which in turn, control bleed air through an integral nozzle/flapper arrangement. The nozzle pressure provides the pneumatic input signal pressure used by the pneumatic valve positioner.

Figure 18. Schematic Illustration of Fisher 3582i Positioner

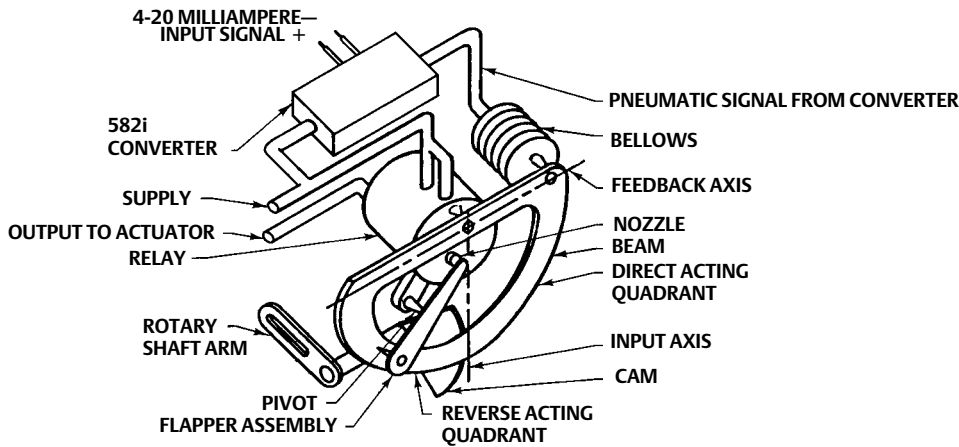

A4818-2

Maintenance

Due to normal wear or damage from external sources (such as debris in the supply medium), periodic maintenance or repair of the valve positioner may be necessary. Maintenance of these units consists of troubleshooting, removal for inspection, and replacement of component parts.

⚠ WARNING

Avoid personal injury from sudden release of process pressure. Before performing any maintenance operations:

- Always wear protective clothing, gloves, and eyewear when performing any maintenance operations.
- Do not remove the actuator from the valve while the valve is still pressurized.
- Disconnect any operating lines providing air pressure, or a control signal to the actuator. Be sure the actuator cannot suddenly open or close the valve.
- When disconnecting any of the pneumatic connections, natural gas, if used as the supply medium, will seep from the unit and any connected equipment into the surrounding atmosphere. Personal injury or property damage may result from fire or explosion if appropriate preventive measures are not taken. Preventive measures may include, but are not limited to, one or more of the following: ensuring adequate ventilation and the removal of any ignition sources.
- Use bypass valves or completely shut off the process to isolate the valve from process pressure. Relieve process pressure on both sides of the valve.
- Use lock-out procedures to be sure that the above measures stay in effect while you work on the equipment.
- Check with your process or safety engineer for any additional measures that must be taken to protect against process media.

⚠ WARNING

3582i does not meet third party approvals for use with natural gas as the supply medium. Use of natural gas as the supply medium can result in personal injury or property damage from fire or explosion,

⚠ WARNING

For explosion proof applications, disconnect power before removing the converter housing cap in an explosive atmosphere.

⚠ WARNING

When replacing components, use only components specified by Emerson. Substitution with other components may result in the positioner no longer meeting safety certification requirements and personal injury or property damage.

Always use proper component replacement techniques. Improper techniques and poor quality repairs can impair the safety features of the device.

In case of operational difficulties, the valve positioner should first be checked to see that adjustments have been properly made. All pressure lines and connections should be checked for leaks.

The pneumatic relay and gaskets should also be inspected and replaced if necessary.

Instructions are given below for:

- changing the range spring;
- replacing gaskets, nozzle O-rings, and relay;
- adjusting the flapper pivot;
- replacing the 582i converter primary O-ring and filter;
- replacing the 582i converter cover O-ring;
- removing the 582i converter; and
- reassembling the 582i converter.

Changing the Range Spring

Unless otherwise noted, key number locations are shown in figure 20.

The range spring is inside the bellows assembly. Standard range spring data is given in table 4. When an input signal range is split to operate two or more control valves, normally changing the range spring is not necessary. The input signal range for the range spring is stamped on the nameplate.

Perform the following procedure to change the range spring in a valve positioner.

1. Unhook the extension springs (keys 27, 77) from the beam (key 29).
2. Loosen and remove the two screws (key 13), and lock washers (key 12) that hold the bellows assembly (key 7) in place.
3. Lift out the beam and bellows assembly. Be careful not to lose the small O-ring (key 11).
4. Loosen the machine screw (key 10), and remove the range spring (key 8).
5. Install a new range spring, making sure the small end of the spring is against the spring seat (key 9). Replace the spring seat and tighten the screw.
6. If the O-ring (key 11) is worn or damaged, replace it with a new one after applying lubricant (key 94). Make sure the O-ring is in place, then install the bellows assembly, securing it with two mounting screws and lock washers.
7. Install the beam over the pivots and hook the springs to the beam.
8. Make any minor adjustments that may be necessary to re-level the beam as outlined in the beam alignment procedures of the valve positioners calibration section. After leveling the beam, calibrate the unit according to the appropriate calibration instructions.

Replacing Gaskets

Unless otherwise noted, key numbers used in this procedure are shown in figures 23 and 24.

A gasket (key 34C) is located behind the bypass handle (key 34D).

1. Remove the screw (key 34G), and lift out the bypass handle or manifold.
2. Remove the gasket.
3. Apply lubricant (key 94) to both sides of the replacement gasket when used with the bypass assembly. Do not apply lubricant to the gasket when the bypass assembly is not used.

4. Set the new gasket in place on the four locating pins and replace the bypass handle or manifold.

The case gasket (key 104) is located between the case (key 1 in figure 20) and the bypass block (key 34A) in a 3582 valve positioner or the housing of the 582i converter (key 1 in figure 25).

5. Remove the two mounting screws (key 105 in figures 23 and 24; key 11 in figure 25) that hold the bypass block or converter housing to the case and remove the unit to expose the case gasket.
6. Install a new gasket and replace the bypass block or converter housing.

Replacing the Nozzle O-Ring

Unless otherwise noted, key numbers are shown in figures 19 and 21.

1. Remove the two screws (key 19C) that hold the flapper and flapper assembly (keys 19B and 19G) to the adjustment arm (key 19A).

CAUTION

For proper operation, be careful not to bend or twist the flapper or nick the nozzle orifice during reassembly.

2. Carefully remove the flapper and flapper assembly for access to the nozzle (key 18 in figure 20).
3. Loosen the locking nut (key 71), and unscrew the nozzle (key 18).
4. Remove the locking sleeve (key 72) from the nozzle adaptor (key 3). The nozzle adaptor is bonded to the positioner case with adhesive (key 96) and should not be removed.
5. Inspect the O-ring (key 73) on the nozzle adapter and replace the O-ring, if necessary. If replacing the O-ring, apply lubricant (key 94) to the O-ring before installing it on the nozzle adapter.
6. Reinstall the nozzle onto the nozzle adapter, leaving the locking nut loose.
7. Replace the flapper and flapper assembly. Make sure the letter "T" on the flapper is visible from the front of the positioner.
8. Perform the beam alignment and calibration procedures in the Calibration of Valve Positioner section.

Replacing the Relay

Note

The relay is not field repairable. If the relay is defective, replace the relay.

Use the following procedure to replace the relay assembly. Refer to figure 20 for key number locations, unless otherwise noted.

1. For valve positioners using a bypass, direct action, and a full-range input signal, place the positioner in bypass operation by moving the bypass handle to BYPASS. Then, shut off the supply pressure. For all other valve positioners isolate the control valve from the system and shut off all pressure lines.

Note

A difference between input and valve positioner output pressure could cause a transient bump in the controlled system when the bypass handle is moved to BYPASS.

2. Remove the 83L relay (key 32) from the back of the case by loosening the two mounting screws (key 10, figure 22).
3. Reinstall the new relay assembly on the case, making sure the O-rings (keys 13 and 15, figure 22) are in place. Secure with the two mounting screws (key 10, figure 22).
4. Resume operation by moving the bypass handle to the POSITIONER position or by connecting the valve positioner and control valve to the system.

Adjusting the Flapper Pivot

Key numbers used in this procedure are shown in figure 19.

1. Loosen the two screws (key 19C).
2. Tighten the pivot pin (key 19L) by compressing the upturned ears of the arm support (key 19K). Tighten the screws (key 19C) and make sure the flapper (key 19B) does not rub on the supports.
3. The flapper should be snug, but not constricting to pivot action.

Replacing the 582i Converter Primary O-Ring and Filter

Key numbers used in this procedure are shown in figure 25.

1. Locate and remove the nozzle restriction adaptor assembly (key 4).
2. Inspect and replace, if necessary, the O-rings (keys 5 and 6). Apply lubricant (key 15) to the O-ring before replacing.
3. Inspect and replace the filter cartridge (key 23).

Replacing the 582i Converter Housing Cap O-Ring

Key numbers used in this procedure are shown in figure 25.

1. Unscrew and remove the converter housing cap (key 2). Inspect and replace the O-ring (key 8), if necessary. Apply lubricant (key 15) to the O-ring before replacing.

Removing the 582i Converter

During the following converter removal procedures, refer to figure 25 for key number locations.

CAUTION

The I/P module should never be disassembled because the magnetism in the coils will decrease permanently. If troubleshooting or alignment attempts indicate a faulty I/P module, replace the module or return the converter to your [Emerson sales office](#) for repair.

Note

To check the operation of the I/P module, remove the pipe plug (key 12), and connect a pressure gauge. Provide a 1.4 bar (20 psig) supply pressure to the converter. With a 4 mA signal the pressure output should read 0.16 to 0.24 bar (2.3 to 3.5 psig). With a 20 mA input signal the pressure output should read 0.96 to 1.07 bar (14.0 to 15.5 psig).

1. Turn off the input signal to the converter. Release all supply pressure from the valve positioner.
2. Remove the housing cap (key 2).
3. Note the location of the wires, disconnect the field wiring from the terminal block. Disconnect the grounding wire from the external ground screw (key 10).
4. To remove the I/P module, remove the two screws (key 9), and pull the module out of the housing. Inspect the O-ring (key 6) and replace it, if necessary. Apply lubricant (key 15) to the O-ring before replacing.
 - a. To remove the entire 582i converter from the 3582i valve positioner, continue with steps 5 through 7.
 - b. To replace the I/P module only, obtain a replacement I/P module listed in the parts list and refer to the procedures for reassembling the 582i converter.
5. Disconnect the supply tubing, output tubing, and electrical conduit from the converter.
6. If necessary, remove the 67CFR regulator by removing the two screws (key 13). Then, remove the regulator from the converter assembly. Inspect the O-ring (key 3) and replace it if necessary. Apply lubricant (key 15) to the O-ring before replacing.
7. Remove the two screws (key 11) holding the 582i converter to the valve positioner case. Remove the converter from the valve positioner case (key 1 in figure 20). Inspect the gasket (key 20) and replace it if necessary.

Reassembling the 582i Converter

During the following converter reassembly procedures, refer to figure 25 for key number locations.

1. If the 582i converter was removed from the valve positioner, install a new gasket (key 20) between the converter housing and the valve positioner case. Attach the converter housing to the valve positioner case with the screws (key 11) and tighten the screws.
2. If the I/P module was removed from the 582i converter, inspect the O-ring (key 6) and replace if necessary, then reinstall the I/P module in the converter housing. Secure the I/P module with the two screws (key 9).
3. If other valve positioner components are removed, refer to the appropriate reassembly procedures and assemble the valve positioner completely.
4. Reconnect the supply tubing, output tubing, and conduit to the valve positioner.
5. Reconnect the wiring to the terminal block. Do not overtighten the terminal screws. Maximum torque is 0.45 N•m (4 lbf•in.). Reconnect the grounding wire to the housing ground screw (key 10) and replace the cap (key 2).

Note

To check the operation of the I/P module, remove the pipe plug (key 12), and connect a pressure gauge. Provide a 1.4 bar (20 psig) supply pressure to the converter. With a 4 milliamper input signal the pressure output should read 0.16 to 0.24 bar (2.3 to 3.5 psig). With a 20 milliamper input signal the pressure output should read 0.96 to 1.07 bar (14.0 to 15.5 psig). Reinstall the pipe plug (key 12). There is no converter module calibration.

CAUTION

Do not apply a signal greater than 35 mA to the I/P module. Higher signal values may damage the converter module.

6. Apply supply pressure and 20 milliamper DC current input signal to the converter.
7. Check for leaks using a soap solution. Check any components which were disassembled or disconnected.

Parts Ordering

A serial number is assigned to each valve positioner and is stamped on the nameplate. Always refer to this number when corresponding with your [Emerson sales office](#) regarding spare parts or technical information.

⚠ WARNING

Use only genuine Fisher replacement parts. Components that are not supplied by Emerson should not, under any circumstances, be used in any Fisher instrument. Use of components not supplied by Emerson may void your warranty, might adversely affect the performance of the instrument, and could cause personal injury or property damage.

Parts Kits

Description	Part Number	Description	Part Number
Repair kit w/nozzle and flapper for the 3582 Positioner Kit contains keys 11, 18, 19B, 19E, 33B, 34C, 73, and 104.		Replacement kit for 83L Relay Kit contains relay, gaskets and mounting screws (key 32 in figure 20, keys 10, 13, and 15 in figure 22)	
For standard temperature applications, not for 3582NS	R3582X00012	For 3582 except 3582NS, std. const.	R3580XRS012
For high temperature applications, not for 3582NS	R3582X00022	For 3582 except 3582NS, Remote Vent, std. temp.	R3580XRR012
For 3582NS, contains EPDM parts	R3582X00032	For 3582 except 3582NS, hi-temp. const.	R3580XRH012
Repair kit for 582i electro-pneumatic converter Kit contains keys 3, 5, 6, 8, 20, and 23	R582X000012	For 3582 except 3582NS, Remote Vent, hi-temp.	R3580XRR022
		For 3582NS	R3580XNS012

Parts List

Note

Contact your [Emerson sales office](#) for Part Ordering information.

Key	Description
11*	O-Ring
12	Lockwasher (2 req'd)
13	Machine Screw (2 req'd)
18	Nozzle
19	Flapper Sub-Assembly

Note

Parts 19A through 19L are shown in figure 19.

Positioner Common Parts (figure 20)

Key	Description
1	Case Assembly
2*	Shaft Assembly For all except 3582NS and high vibration For travel up to 54 mm (2.125 inch) For travel up to 102 mm (4 inch) For 3582NS and high vibration For travel up to 54 mm (2.125 inch) For travel up to 102 mm (4 inch)
3	Nozzle Adaptor
4	Cam, Standard Cam A (For all types except 3582NS) Cam B (For all except 3582NS) Cam C (For all except 3582NS)
4	Cam, for 3582NS and high vibration Cam A Cam B Cam C
6	Cam Bolt
7*	Bellows Assembly
8	Range Spring (see table 4) 0.2 to 1.0 bar (3 to 15 psi) 0.4 to 2.0 bar (6 to 30 psi)
9	Spring Seat
10	Machine Screw

19A	Adjustment Arm
19B	Flapper
19C	Machine Screw (2 req'd)
19D	Flapper Arm
19E	Machine Screw (2 req'd)
19F	Flapper Spring
19G	Flapper Assembly Screw

19H	Hex Nut
19J	Lockwasher
19K	Arm Support
19L	Pivot Pin

20	Setting Adjustment Gear
----	-------------------------

Figure 19. Flapper Sub-Assembly (Key 19)

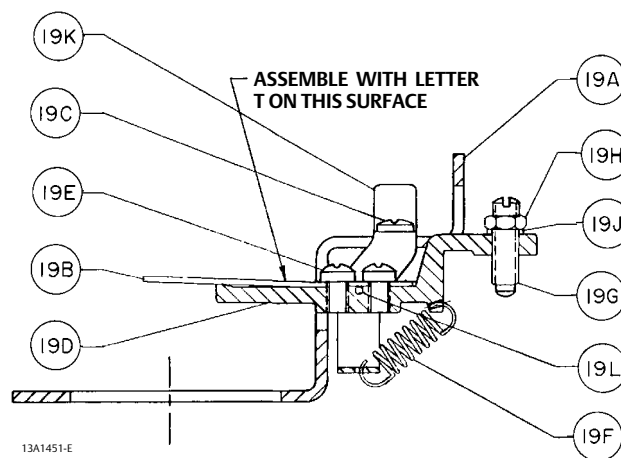
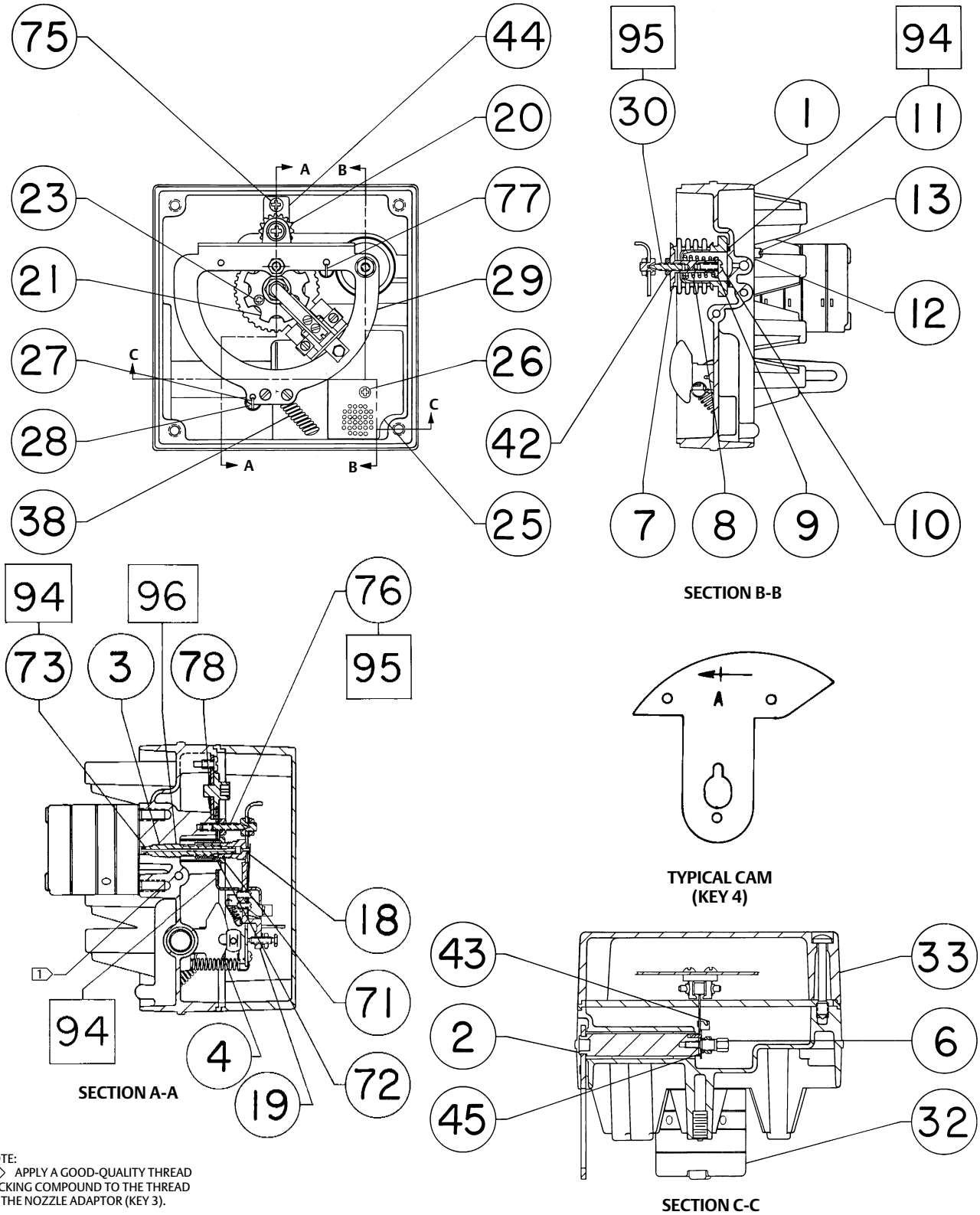
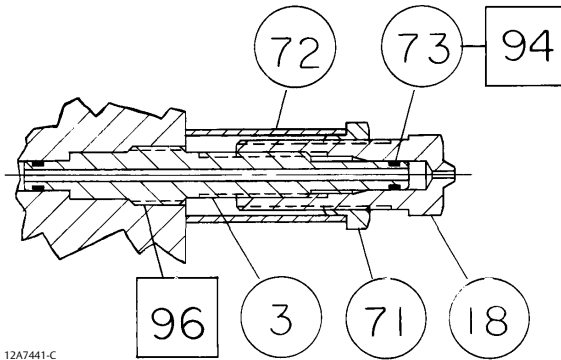

Figure 20. Fisher 3582 Positioner Assembly Drawing



NOTE:
 [T] APPLY A GOOD-QUALITY THREAD LOCKING COMPOUND TO THE THREAD OF THE NOZZLE ADAPTOR (KEY 3).

Figure 21. Nozzle Sub-Assembly



12A7441-C

Figure 22. 83L Relay

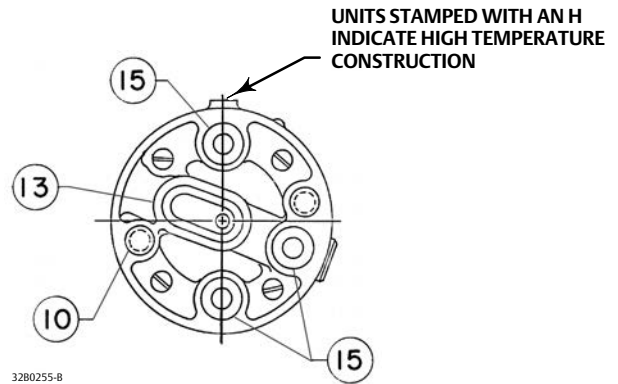

32B0255-B

Key	Description	Part Number
21	Flapper Assembly Retainer	
23	Self Tapping Screw (2 req'd)	
25	Nameplate	
26	Self Tapping Screw (2 req'd)	
27	Extension Spring	
28	Machine Screw (3 req'd)	
29	Beam Sub-Assembly For all except 3582NS and high vibration For 3582NS and high vibration	
30	Bellows Pivot Pin	
32*	83L Relay (figure 22) See Parts Kits, Replacement Kit for 83L Relay	
33	Cover Assembly	22B4905X012

Note

Bypass block assembly (key 34) and parts are listed later in this parts list. Non-bypass block assembly (also key 34) and parts are listed following the bypass block assembly and parts.

Parts 35, 36 and 37 are shown in figures 23 and 24.

35	Pipe Plug Req'd when gauges or test connections are not used: 3 req'd for 3582 positioners	
36*	Output Gauge, Dual Scale 3582, 3582G 0-30 psig/0-2 kg/cm ² 0-60 psig/0-4 kg/cm ²	11B4040X042 11B4040X052

Key	Description	Part Number
36*	Output Gauge, Triple Scale 3582, 3582G 0-30 psig/0-0.2 MPa/0-2 bar 0-60 psig/0-0.4 MPa/0-4 bar	11B4040X012 11B4040X022
37*	Supply Gauge, Dual Scale 3582, 3582G 0-30 psig/0-2 kg/cm ² 0-60 psig/0-4 kg/cm ²	11B4040X042 11B4040X052
37*	Supply Gauge, Triple Scale 3582, 3582G 0-30 psig/0-0.2 MPa/0-2 bar 0-60 psig/0-0.4 MPa/0-4 bar	11B4040X012 11B4040X022
38	Extension Spring,	
39	Shipping Stop (not shown)	
42	Hex Nut (2 req'd)	
43	Spring Retainer Bracket	
44	Gear Mounting Plate	
45	Locking Nut	

Note

Parts 46 and 47 are shown in figures 23 and 24.

46*	Instrument Gauge, Dual Scale 0-30 psig/0-2 kg/cm ² (3-15 psig/0.2-1.0 kg/cm ² ranges) 0-60 psig/0-4 kg/cm ² (6-30 psig/0.4-2.0 kg/cm ² ranges)	11B4040X042 11B4040X052
46*	Instrument Gauge, Triple Scale 0-30 psig/0-0.2 MPa/0-2 bar (3-15 psig/20-100 kPa/0.2-1 bar ranges) 0-60 psig/0-0.4 MPa/0-4 bar (6-30 psig/40-200 kPa/0.4-2 bar ranges)	11B4040X012 11B4040X022

*Recommended spare parts

Key	Description	Key	Description
47	Test Connection 3582C, 3582D (3 req'd) 3582NS (3 req'd)	96	Adhesive, Loctite™ 680™ Retaining Compound (not furnished with positioner)
71	Locking Nut	103*	O-Ring, (not shown) used with integrally mounted 67CFR filter regulator
72	Locking Sleeve		
73*	O-Ring (2 req'd) Std. const. All except 3582NS Hi-temp. const. 3582A, 3582C 3582NS	<hr/>	
		Note	
		Parts 104 and 105 shown in figures 23 and 24.	
75	Machine Screw		
76	Beam Pivot Pin		
77	Extension Spring		
78	Speed Nut		
93	Anti-Seize sealant (not furnished with positioner)	104*	Case Gasket, Std. const. Hi-temp. const. 3582NS
94	Lubricant, silicone sealant (not furnished with positioner)	105	Machine Screw (2 req'd)
95	Lubricant, All except 3582NS, Lithium grease (not furnished with positioner) 3582NS, Molykote™ 33 grease (not furnished with positioner)	108	Shipping tag (not shown)

For Units With Bypass (figure 23)

Note

Bypass block assembly (key 34) and parts are listed below. Non-bypass block assembly (also key 34) and parts are listed following the bypass block assembly and parts.

Key	Description
34	Block Assembly 3582, 3582D 3582NS

Key Description

34A	Bypass Block
34B*	Groove-Pin (not shown) (4 req'd)
34C*	Bypass Gasket 3582, 3582D 3582NS
34D	Bypass Handle
34E	Spring,
34F	Washer
34G	Screw
34K	Spring Seat
34L	Spring Retainer

Figure 23. Fisher 3582 Block Assembly with Bypass

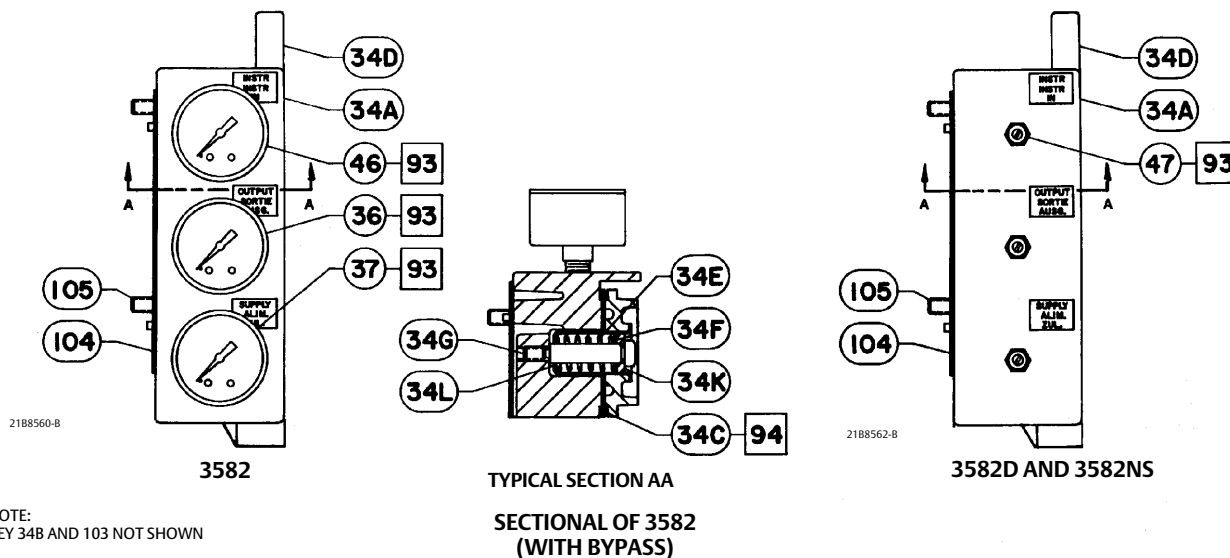

For Units Without Bypass (figure 24)

Key Description

34 Non-Bypass Block Assembly
 Std. const.
 3582A, 3582C, 3582G
 3582C
 Hi-temp. const.
 3582A, 3582C
 3582NS

Key Description

34A Bypass Block
 34C* Gasket
 Std. Const.
 Hi-temp. const.
 3582NS
 34D Manifold
 3582, std. and hi-temp. const.
 34G Cap Screw
 34C

Figure 24. Fisher 3582 Block Assemblies without Bypass

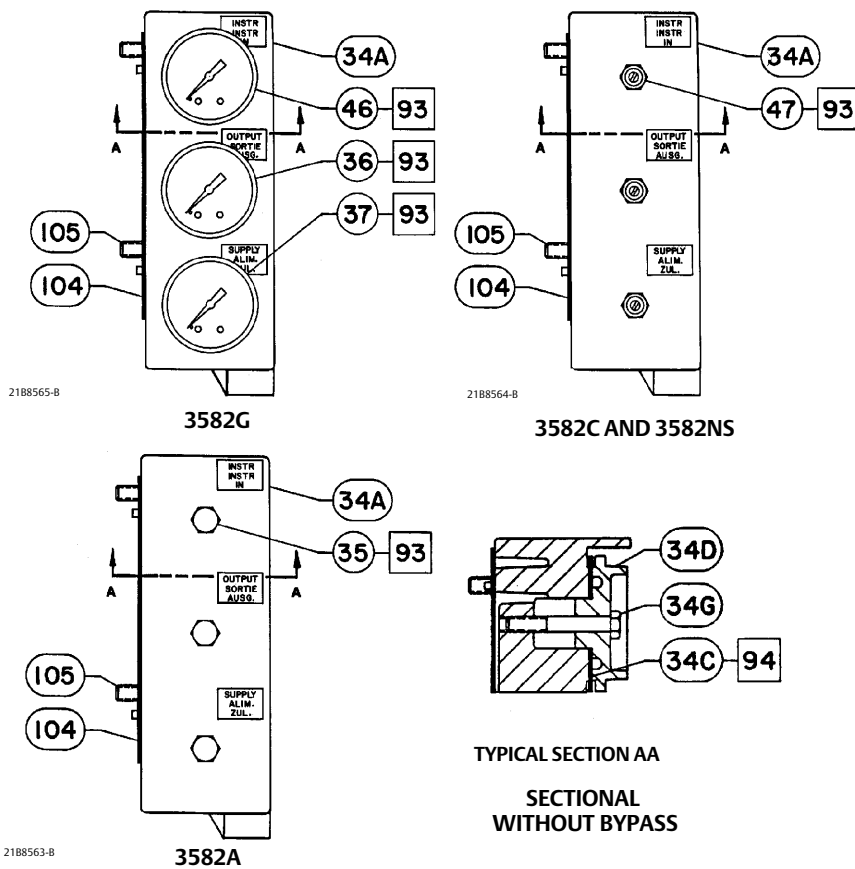

Key	Description	Part Number	Key	Description	Part Number
582i (figure 25)					
---	I/P Module	33B7073X032	14*	Supply Gauge, Dual Scale 0-30 psig/0-2 kg/cm ² 0-60 psig/0-4 kg/cm ²	11B4040X042 11B4040X052
1	Housing 1/2-14 NPT conduit connection		14*	Supply Gauge, Triple Scale 0-30 psig/0-0.2 MPa/0-2 bar 0-60 psig/0-0.4 MPa/0-4 bar	11B4040X012 11B4040X022
2	Cap		15	Lubricant, Lithium grease (not furnished with positioner)	
---	Screw, (not shown) Used to lock cap		16	Anti-seize sealant (not furnished with positioner)	
3*	O-Ring, used with integrally-mounted 67CFR filter regulator		18	Self-Tapping Screw (2 req'd)	
4	Nozzle Restriction Assembly		19	Nameplate, without 3rd party approvals	
5	O-Ring		20*	Case Gasket	
6*	O-Ring (2 req'd)		22*	Output Gauge, Dual Scale 0-30 psig/0-2 kg/cm ² 0-60 psig/0-4 kg/cm ²	11B4040X042 11B4040X052
7	Tire Valve (not shown) (2 req'd w/tire valve option)		22*	Output Gauge, Triple Scale 0-30 psig/0-0.2 MPa/0-2 bar 0-60 psig/0-0.4 MPa/0-4 bar	11B4040X012 11B4040X022
8*	O-Ring		23*	Filter	
9	Machine Screw (2 req'd)		24	Vent Assembly	
10	Wire Retaining Screw (2 req'd)		25	Pipe Plug (required when a 582i is used without an integrally-mounted 67CFR filter/regulator)	
11	Machine Screw (2 req'd)				
12	Pipe Plug (2 req'd w/pipe plug option)				
13	Screw, used with integrally-mounted 67CFR filter/regulator (2 req'd)				

Figure 25. Fisher 582i Converter

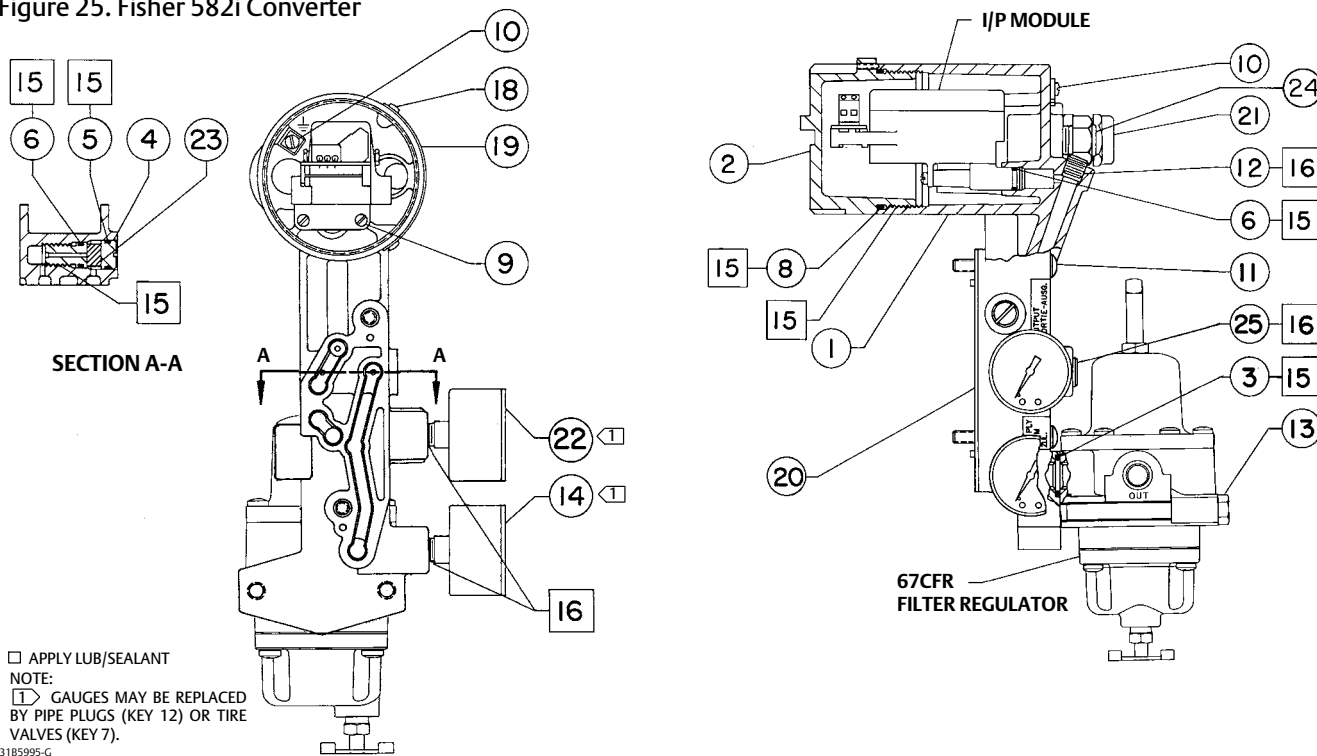

Mounting Parts

For Mounting 3582 or 3582i (figure 2)

Key	Description	Key	Description
48	Connector Arm 513 Size 20 Size 32 656 Size 30, 40, & 60 657 or 667 w/o side-mtd. h'wheel Sizes 30 & 34 Sizes 40 thru 100 w/side-mtd. h'wheel Size 34 Sizes 40, 50, & 60 Size 45 & 46 Sizes 70 thru 100 657NS or 667NS Size 40 Size 45 Size 70 Size 80 657-4, 667-4 GX Size 225, 750, 1200	49	Washer 657 w/o side-mtd. h'wheel (continued) Size 70 (2 req'd) up to 76 mm (3 inch) travel 78 to 102 mm (3.0625 to 4 inch) travel Sizes 80 & 87 (2 req'd) Size 100 (2 req'd) 657-4 (2 req'd) w/o side-mtd. h'wheel Size 70 w/side-mtd. h'wheel Size 70 Size 87 667 w/o side-mtd. h'wheel Sizes 30, 34, & 40 (2 req'd) Size 45 thru 70, & 100 (2 req'd) Size 80 (2 req'd) Size 87 up to 51 mm (2 inch) travel 52 to 76 mm (2.0625 to 3 inch) travel 78 to 102 mm (3.0625 to 4 inch) travel 667 w/side-mtd. h'wheel Size 34 thru 60 (none req'd) Size 70 (2 req'd) up to 76 mm (3 inch) travel 78 to 102 mm (3.0625 to 4 inch) travel Size 80 & 87 (2 req'd) Size 100 (2 req'd) 657NS or 667NS Size 40 (2 req'd) Size 45 (2 req'd) Size 70 and 80 (none req'd) 667-4 (2 req'd) w/ or w/o side-mtd h'wheel Size 70 Size 87
49	Washer 513 Size 20 6.4 mm (0.25 inch) stem (none req'd) 7.9 mm (0.3125 inch) stem (1 req'd) 9.5 mm (0.375 inch) stem (1 req'd) Size 32 (2 req'd) 656 Size 30, 40, & 60 12.7 mm (0.5 inch) stem (1 req'd) 19.1 mm (0.75 inch) stem (none req'd) 657 w/o side-mtd. h'wheel Sizes 30, 34, & 40 (2 req'd) Size 45 thru 70, & 100 (2 req'd) Sizes 80 & 87 (2 req'd) w/side-mtd. h'wheel Size 34 thru 60 (none req'd)	50	Spacer 513 Size 20 (none req'd) Size 32 (2 req'd) 656 (2 req'd) Sizes 30, 40, & 60 657 w/o side-mtd. h'wheel Size 30 thru 60 (none req'd) Size 70 up to 51 mm (2 inch) travel (2 req'd) 52 to 76 mm (2.0625 to 3 inch) travel (none req'd) 78 to 102 mm (3.0625 to 4 inch) travel (2 req'd) Size 80 up to 51 mm (2 inch) travel (none req'd) over 51 mm (2 inch) travel (2 req'd) Size 87 (2 req'd) up to 76 mm (3 inch) travel 78 to 102 mm (3.0625 to 4 inch) travel Size 100 (2 req'd) up to 64 mm (2.5 inch) travel 65 to 102 mm (2.5625 to 4 inch) travel

Key	Description	Key	Description
50	Spacer 657 (continued) w/side-mtd. h'wheel Sizes 34, 50, & 60 (2 req'd) Size 40 (none req'd) Size 45 & 46 (2 req'd) Sizes 70 & 87 (2 req'd) Size 80 up to 51 mm (2 inch) travel (none req'd) over 51 mm (2 inch) travel (2 req'd) Size 100 (2 req'd) up to 64 mm (2.5 inch) travel 65 to 102 mm (2.5625 to 4 inch) travel 657-4 (2 req'd) w/o side-mtd. h'wheel Size 70 w/side-mtd. h'wheel Size 70 & 87 667 w/o side-mtd. h'wheel Sizes 30 thru 60 (none req'd) Size 70 up to 51 mm (2 inch) travel (none req'd) 52 to 76 mm (2.0625 to 3 inch) travel (2 req'd) 78 to 102 mm (3.0625 to 4 inch) travel (2 req'd) Size 80 up to 51 mm (2 inch) travel (none req'd) over 51 mm (2 inch) travel (2 req'd) Size 87 (2 req'd) up to 76 mm (3 inch) travel 78 to 102 mm (3.0625 to 4 inch) travel Size 100 (2 req'd) up to 64 mm (2.5 inch) travel 65 to 102 mm (2.5625 to 4 inch) travel w/side-mtd. h'wheel Size 34 (2 req'd) Sizes 40, 50, & 60 (none req'd) Size 45 & 46 (2 req'd) Sizes 70 & 87 Size 80 up to 51 mm (2 inch) travel (none req'd) over 51 mm (2 inch) travel (2 req'd) w/side-mtd. h'wheel (cont'd) Size 100 up to 64 mm (2.5 inch) travel 65 to 102 mm (2.5625 to 4 inch) travel 657NS or 667NS All except size 80 (3 req'd) Size 80 (none req'd) 667-4 w/ or w/o side-mtd h'wheel Sizes 70 & 87	57	Hex Nut 657NS or 667NS Size 80 (none req'd) All other types and sizes (2 req'd)
52	Pipe Plug	58	Lockwasher 657NS or 667NS Size 80 (none req'd) All other types and sizes (2 req'd)
54	Elbow, 3/8-inch (specify quantity)	59	Pin Lock
55	Connector, 3/8-inch (not shown) (specify quantity)	60	Travel Pin 657NS or 667NS Size 80 All other types
56	Cap Screw (2 req'd) 657NS or 667NS Sizes 40, 45, & 70 All other types	61	Pin Holder
		62	Cap Nut
		63	Mounting Plate For integrally mounted 67CFR For separately mounted 67CFR
		64	Cap Screw (5 req'd)
		65	Cap Screw, hex head (2 req'd) GX Size 225, 750, 1200
		70	Cap Screw (2 req'd) 513 Size 20 & 32 (2 req'd) 656 Size 30, 40, & 60 (2 req'd) 657 w/o side-mtd. h'wheel Sizes 30 thru 60 Size 70 Up to 51 mm (2 inch) travel 52 to 76 mm (2.0625 to 3 inch) travel 78 to 102 mm (3.0625 to 4 inch) travel Size 80 up to 51 mm (2 inch) travel over 51 mm (2 inch) travel 657 w/o side-mtd. h'wheel Size 87 up to 76 mm (3 inch) travel 78 to 102 mm (3.0625 to 4 inch) travel Size 100 up to 64 mm (2.5 inch) travel 65 to 102 mm (2.5625 to 4 inch) travel w/side-mtd. h'wheel Sizes 34, 50, & 60 Size 40 Size 45 & 46 Sizes 70 & 87 Size 80 up to 51 mm (2 inch) travel over 51 mm (2 inch) travel

Key	Description	Key	Description			
70	<p>Cap Screw (2 req'd)</p> <p>657 w/side-mtd. h'wheel (continued) Size 100 up to 64 mm (2.5 inch) travel 65 to 102 mm (2.5625 to 4 inch) travel</p> <p>657-4 w/o side-mtd. h'wheel Size 70 w/side-mtd. h'wheel Sizes 70 & 87</p> <p>667 w/o side-mtd. h'wheel Size 30 thru 60 Size 70 Up to 51 mm (2 inch) travel 52 to 76 mm (2.0625 to 3 inch) travel 78 to 102 mm (3.0625 to 4 inch) travel Size 80 up to 51 mm (2 inch) travel over 51 mm (2 inch) travel Size 87 Up to 76 mm (3 inch) travel 78 to 102 mm (3.0625 to 4 inch) travel Size 100 up to 64 mm (2.5 inch) travel 65 to 102 mm (2.5625 to 4 inch) travel w/side-mtd. h'wheel Size 34 Size 40, 50, 60 Size 45 & 46 Size 70 & 87 Size 80 up to 51 mm (2 inch) travel over 51 mm (2 inch) travel Size 100 up to 64 mm (2.5 inch) travel 65 to 102 mm (2.5625 to 4 inch) travel</p> <p>657NS or 667NS Size 40, 45, & 70 (3 req'd) Size 80 (3 req'd)</p> <p>667-4 Sizes 70 & 87</p> <p>GX Size 225, 750, 1200 For Competitor's Actuators 0.375 to 0.75 inch stem</p>	<p>97</p>	<p>Spacer</p> <p>657 or 667 w/ side-mtd. h'wheel Size 70 & 87 up to 51 mm (2 inch) travel (2 req'd) 52 to 76 mm (2.0625 to 3 inch) travel (2 req'd) 78 to 102 mm (3.0625 to 4 inch) travel (none req'd) w/ or w/o side-mtd. h'wheel Size 80 up to 51 mm (2 inch) travel (2 req'd) over 51 mm (2 inch) travel (none req'd) All other types and sizes (none req'd)</p> <p>98</p>	<p>Stud, continuous thread (2 req'd)</p> <p>657 or 667 w/ side-mtd. h'wheel Size 70 & 87 up to 76 mm (3 inch) travel (2 req'd) 78 to 102 mm (3.0625 to 4 inch) travel (none req'd) w/ or w/o side-mtd. h'wheel Size 80 up to 51 mm (2 inch) travel over 51 mm (2 inch) travel (none req'd) All other types and sizes (none req'd)</p> <p>99</p>	<p>Hex Nut</p> <p>657 or 667 w/ side-mtd. h'wheel Size 70 & 87 up to 76 mm (3 inch) travel (2 req'd) 78 to 102 mm (3.0625 to 4 inch) travel (none req'd) w/ or w/o side-mtd. h'wheel Size 80 up to 51 mm (2 inch) travel (2 req'd) over 51 mm (2 inch) travel (none req'd) All other types and sizes (none req'd)</p> <p>102</p>	<p>Spacer</p> <p>657 w/o side-mtd h'wheel Size 34 to 60 (none req'd) Size 70 up to 51 mm (2 inch) travel (2 req'd) 52 to 102 mm (2.0625 to 4 inch) travel (none req'd) Size 87 up to 51 mm (2 inch) travel (2 req'd) 52 to 102 mm (2.0625 to 4 inch) travel (none req'd)</p> <p>667 w/o side-mtd h'wheel Size 34 thru 70 & 87 (none req'd)</p> <p>657 or 667 w/ side-mtd. h'wheel Size 34 thru 60 (none req'd) Size 70 & 87 up to 76 mm (3 inch) travel (2 req'd) Size 70 78 to 102 mm (3.0625 to 4 inch) travel (4 req'd) Size 87 78 to 102 mm (3.0625 to 4 inch) travel, (2 req'd) w/ or w/o side-mtd. h'wheel Size 80 (2 req'd) Size 100 up to 64 mm (2.5 inch) travel (4 req'd) 65 mm to 102 mm (2.5625 to 4 inch) travel (2 req'd)</p>
85	<p>Cap Screw, hex head (4 req'd)</p> <p>GX Size 225, 750, 1200</p>					
86	<p>Mounting Bracket (657NS and 667NS only)</p> <p>657NS Size 45</p> <p>667NS Size 45</p> <p>657NS or 667NS Size 40 Size 70 Size 80</p>					

Key	Description	Key	Description
102	Spacer (continued) 657 w/o side-mtd h'wheel Size 34 to 60 (none req'd) 657-4 or 667-4 w/o side-mtd h'wheel Size 70 (none req'd) w/ side-mtd. h'wheel Size 70 (4 req'd) Size 87 (2 req'd) GX Size 1200 All other types (none req'd)	50	Spacer 657 Size 70 & 87 up to 76 mm (3 inch) travel (none req'd) 77 to 102 mm (3.0625 to 4 inch) travel (4 req'd) 667 Size 70 & 87 up to 51 mm (2 inch) travel (none req'd) 52 to 76 mm (2.0625 to 3 inch) travel (4 req'd) 77 to 102 mm (3.0625 to 4 inch) travel (4 req'd) 657 Size 70 & 87 up to 76 mm (3 inch) travel (none req'd) 657 or 667 Sizes 30 thru 60, & 80 (none req'd) Size 100 (4 req'd) up to 64 mm (2.5 inch) travel 65 to 102 mm (2.5625 to 4 inch) travel
		59	Pin Lock, all sizes (2 req'd)
		60	Travel Pin, all sizes (2 req'd)
		61	Pin Holder, all sizes (2 req'd)
		62	Cap Nut, all sizes (2 req'd)
		63	Mounting Plate, all sizes (2 req'd) For integrally mounted 67CFR For separately mounted 67CFR
		64	Cap Screw, all sizes (8 req'd)
		65	Cap Screw 513 Size 20 (none req'd) Size 32 (2 req'd) 656 (none req'd) 657 w/o side-mtd. h'wheel Sizes 30, 34, & 40 (2 req'd) Sizes 45 thru 60 (none req'd) Size 70 (2 req'd) up to 51 mm (2 inch) travel 52 to 102 mm (2.0625 to 4 inch) travel Size 80 up to 51 mm (2 inch) travel (none req'd) over 51 mm (2 inch) travel (2 req'd) Size 87 up to 51 mm (2 inch) travel (2 req'd) 52 to 102 mm (2.0625 to 4 inch) travel (none req'd) Size 100 (2 req'd) up to 64 mm (2.5 inch) travel 65 to 102 mm (2.5625 to 4 inch) travel w/side-mtd. h'wheel Sizes 34 thru 60 (none required) Size 70 up to 76 mm (3 inch) travel (none req'd) 78 to 102 mm (3.0625 to 4 inch) travel (2 req'd) Size 80 up to 51 mm (2 inch) travel (none req'd) over 51 mm (2 inch) travel (2 req'd)
<hr/>			
Note			
The following parts (key numbers 48 through 102) are used when mounting the positioner on a 657 or 667 actuator without a side-mounted handwheel.			
<hr/>			
48	Connector Arm (2 req'd) Sizes 30 & 34 Sizes 40 thru 100		
49	Washer (4 req'd) 657 Size 70 up to 51 mm (2 inch) travel 52 mm to 76 mm (2.0625 to 3 inch) travel 77 to 102 mm (3.0625 to 4 inch) travel Size 87 667 Size 70, all travels Size 87 up to 76 mm (3 inch) travel 77 to 102 mm (3.0625 to 4 inch) travel 657 or 667 Size 30 thru 40 Size 45 thru 60 Size 80 Size 100 up to 64 mm (2.5 inch) travel 65 to 102 mm (2.5625 to 4 inch) travel		

Key	Description	Key	Description
65	Cap Screw	70	Cap Screw (4 req'd) (continued)
	657		657 or 667
	w/side-mtd. h'wheel (continued)		Sizes 30 thru 60, & 80
	Size 87		Size 100
	up to 76 mm (3 inch) travel (none req'd)		up to 64 mm (2.5 inch) travel
	78 to 102 mm (3.0625 to 4 inch) travel		65 to 102 mm (2.5625 to 4 inch) travel
	(2 req'd)		
	Size 100 (2 req'd)	71	Stud, continuous thread (not shown) (2 req'd)
	up to 64 mm (2.5 inch) travel		657
	65 to 102 mm (2.5625 to 4 inch) travel		Size 70
	657-4 (2 req'd)		Size 87
	w/o side-mtd. h'wheel		Up to 51 mm (2 inch) travel
	Size 70		52 to 102 mm (2.0625 to 4 inch) travel
	w/ side-mtd. h'wheel		667
	Size 70		Size 70
	Size 87		Up to 76 mm (3 inch) travel
	667		77 to 102 mm (3.0625 to 4 inch) travel
	w/o side-mtd. h'wheel		Size 87
	Sizes 30, 34, & 40 (2 req'd)		Up to 76 mm (3 inch) travel
	Sizes 45 thru 70, & 87 (none req'd)		77 to 102 mm (3.0625 to 4 inch) travel
	Size 80		657 or 667
	up to 51 mm (2 inch) travel (none req'd)		Sizes 30, 34, & 40
	over 51 mm (2 inch) travel (2 req'd)		Sizes 45 thru 60
	Size 100 (2 req'd)		Size 80
	Up to 64 mm (2.5 inch) travel		Size 100 (none req'd)
	65 to 102 mm (2.5625 to 4 inch) travel		
	w/side-mtd. h'wheel	72	Hex Nut (not shown) (4 req'd)
	Sizes 34 thru 60 (none required)		657 or 667
	Size 70		Sizes 30, 34, & 40
	up to 76 mm (3 inch) travel (none req'd)		Sizes 45 thru 60
	78 to 102 mm (3.0625 to 4 inch) travel (2 req'd)		Size 70
	667		Size 80 & 87
	w/side-mtd. h'wheel		Size 100 (none req'd)
	Size 80	102	Spacer
	up to 51 mm (2 inch) travel (none req'd)		657
	over 51 mm (2 inch) travel (2 req'd)		Size 70
	Size 87		Up to 51 mm (2 inch) travel (4 req'd)
	up to 76 mm (3 inch) travel (none req'd)		52 to 102 mm (2.0625 to 4 inch) travel (none req'd)
	78 to 102 mm (3.0625 to 4 inch) travel		Size 87
	(2 req'd)		Up to 51 mm (2 inch) travel
	Size 100 (2 req'd)		52 to 102 mm (2.0625 to 4 inch) travel (none req'd)
	up to 64 mm (2.5 inch) travel		Size 70
	65 to 102 mm (2.5625 to 4 inch) travel		Up to 51 mm (2 inch) travel (4 req'd)
	657NS or 667NS		667
	Size 40, 45, 70, & 80 (none req'd)		Size 70
	667-4		Up to 76 mm (3 inch) travel (none req'd)
	w/o side-mtd. h'wheel		77 to 102 mm (3.0625 to 4 inch) travel (4 req'd)
	Size 70 & 87 (none req'd)		Size 87
	667-4 (cont'd)		Up to 76 mm (3 inch) travel (none req'd)
	w/ side-mtd. h'wheel		77 to 102 mm (3.0625 to 4 inch) travel (4 req'd)
	Size 70 (2 req'd)		657 or 667
	Size 87 (2 req'd)		Sizes 30 thru 60 (none req'd)
			Size 80 (4 req'd)
70	Cap Screw (4 req'd)		Size 100
	657		up to 64 mm (2.5 inch) travel (8 req'd)
	Size 70 & 87		65 to 102 mm (2.5625 to 4 inch) travel (4 req'd)
	Up to 76 mm (3 inch) travel		
	78 to 102 mm (3.0625 to 4 inch) travel		
	667		
	Size 70 & 87		
	Up to 51 mm (2 inch) travel		
	52 to 76 mm (2.0625 to 3 inch) travel		
	77 to 102 mm (3.0625 to 4 inch) travel		

For Mounting 3582 and 3582i on 657 or 667 Actuator with Side-Mounted Handwheel

Key Description

Note

The following parts (key numbers 48 through 87) are used when mounting the positioner on a 657 or 667 Size 45 actuator with side-mounted handwheel.

- 48 Connector Arm
- 50 Spacer (2 req'd)
- 54 Elbow, 3/8-inch
- 55 Connector, 3/8-inch (not shown)
- 59 Pin Lock (2 req'd)

Key Description

- 60 Travel Pin (2 req'd)
- 61 Pin Holder (2 req'd)
- 62 Cap Nut (2 req'd)
- 63 Mounting Plate (2 req'd)
For integrally mounted 67CFR
For separately mounted 67CFR
- 64 Cap Screw (8 req'd)
- 70 Cap Screw (2 req'd)
- 79 Mounting Plate
- 80 Hex Nut, for 667 only (2 req'd)
- 81 Lockwasher
657 (2 req'd)
667 (4 req'd)
- 82 Machine Screw (2 req'd)
- 83 Elastic Stop Nut (not shown) (2 req'd)
- 84 Connecting Linkage
- 85 Cap Screw, for 667 only (5 req'd)
- 86 Spacer, for 667 only (5 req'd)
- 87 Cap Screw, for 667 only (2 req'd)

Figure 26. Typical Positioner Application

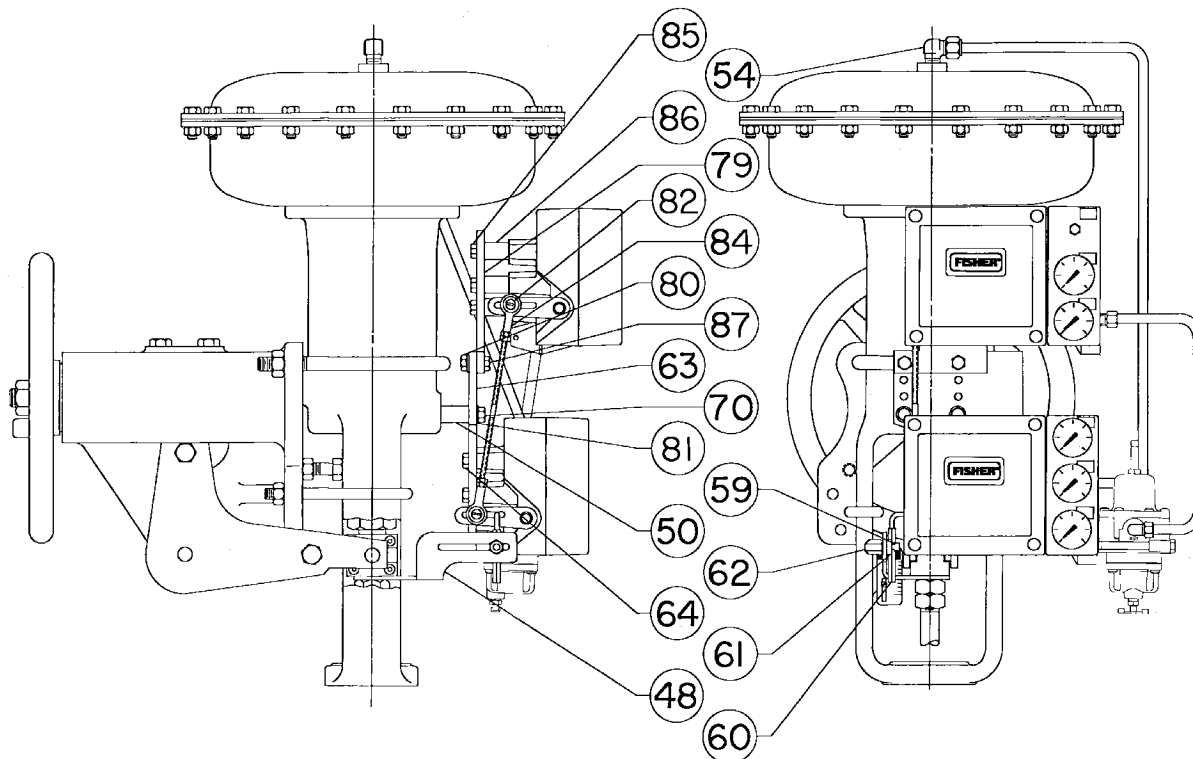

Diagnostic Connections (figure 8)

FlowScanner™ valve diagnostics system hook-up.

Includes connector body and body protector. If ordered for units with gauges, a stem is also included.

Description

For 3582 pneumatic valve positioners

For units w/gauges

For units w/o gauges

Neither Emerson, Emerson Automation Solutions, nor any of their affiliated entities assumes responsibility for the selection, use or maintenance of any product. Responsibility for proper selection, use, and maintenance of any product remains solely with the purchaser and end user.

Fisher and FlowScanner are marks owned by one of the companies in the Emerson Automation Solutions business unit of Emerson Electric Co. Emerson Automation Solutions, Emerson, and the Emerson logo are trademarks and service marks of Emerson Electric Co. All other marks are the property of their respective owners.

The contents of this publication are presented for informational purposes only, and while every effort has been made to ensure their accuracy, they are not to be construed as warranties or guarantees, express or implied, regarding the products or services described herein or their use or applicability. All sales are governed by our terms and conditions, which are available upon request. We reserve the right to modify or improve the designs or specifications of such products at any time without notice.

Emerson Automation Solutions

Marshalltown, Iowa 50158 USA

Sorocaba, 18087 Brazil

Cernay, 68700 France

Dubai, United Arab Emirates

Singapore 128461 Singapore

www.Fisher.com

