

Fisher™ YD and YS 3-Way Valves

Contents

Introduction	1
Scope of Manual	1
Specifications	2
Educational Services	2
Installation	3
Maintenance	4
Packing Lubrication	5
Packing Maintenance	6
Packing Replacement	6
Trim Maintenance	7
Disassembly	7
Assembly	12
ENVIRO-SEAL™ Bellows Seal Bonnet	16
Replacing a Plain or Extension Bonnet with an ENVIRO-SEAL Bellows Seal Bonnet (Stem/Bellows Assembly)	16
Replacement of an Installed ENVIRO-SEAL Bellows Seal Bonnet (Stem/Bellows Assembly)	18
Purging the ENVIRO-SEAL Bellows Seal Bonnet	19
Parts Ordering	24
Parts Kits	24
Gasket Kits	25
Parts List	26
YD and YS Valve	26
Bonnet for YD and YS	26

Figure 1. Fisher YD Valve with 667 Actuator



W2081

Introduction

Scope of Manual

This instruction manual includes installation, maintenance, and parts information for NPS 1/2 through 8 YD and NPS 1/2 through 6 YS control valves. Refer to separate manuals for instructions covering the actuators and accessories.

Do not install, operate, or maintain YD or YS valves without being fully trained and qualified in valve, actuator, and accessory installation, operation, and maintenance. To avoid personal injury or property damage, it is important to carefully read, understand, and follow all the contents of this manual, including all safety cautions and warnings. If you have any questions about these instructions, contact your [Emerson sales office](#) or Local Business Partner before proceeding.

Table 1. Specifications

<p>Valve Sizes, Ratings, and End Connections^(1,2)</p> <p>Cast Iron Valves <i>Flanged:</i> NPS 1-1/2 through 6 CL125 flat-face or CL250 raised-face flanges per ASME B16.1 <i>Screwed:</i> NPS 1-1/2 and 2 consistent with ASME B16.4</p> <p>Steel and Stainless Steel Valves <i>Flanged:</i> NPS 1 through 8 CL150, 300, and 600 raised-face or ring-type joint flanges per ASME B16.5 <i>Screwed or Socket Welding:</i> NPS 1/2 through 2 consistent with ASME B16.11 <i>Buttwelding:</i> NPS 1 through 8. All available ASME B16.25 schedules that are consistent with ASME B16.34</p> <p>Also see table 2</p> <p>Maximum Inlet Pressure⁽¹⁾</p> <p>Cast Iron Valves <i>Flanged:</i> Consistent with CL125B or 250B per ASME B16.1 <i>Screwed:</i> Consistent with CL250 per ASME B16.4</p> <p>WCC and Stainless Steel Valves <i>Flanged:</i> Consistent with CL150, 300, and 600⁽³⁾ per ASME B16.34 <i>Screwed or Welding:</i> Consistent with flanged CL600 per ASME B16.34</p>	<p>Do not exceed the pressure, temperature, and pressure drop conditions specified when the valve was ordered. See the Installation section for additional information.</p> <p>Shutoff Classifications per ANSI/FCI 70-2 and IEC 60534-4</p> <p>YD <i>Standard Design:</i> Class IV <i>High-Temperature Design:</i> Class II</p> <p>YS <i>Standard Class:</i> Class IV <i>Optional Class:</i> Class V</p> <p>Flow Characteristic</p> <p>Linear</p> <p>Approximate Shipping Weights</p> <p>NPS 1/2, 3/4 Valves: 14 kg (30 pounds) NPS 1 Valves: 18 kg (40 pounds) NPS 1-1/2 Valves: 27 kg (60 pounds) NPS 2 Valves: 39 kg (85 pounds) NPS 2-1/2 Valves: 50 kg (110 pounds) NPS 3 Valves: 68 kg (150 pounds) NPS 4 Valves: 109 kg (240 pounds) NPS 6 Valves: 227 kg (500 pounds) NPS 8 Valves: 447 kg (985 pounds)</p>
<p>1. EN (or other) ratings and end connections can usually be supplied; consult your Emerson sales office or Local Business Partner. 2. The pressure or temperature limits in this manual, and any applicable standard limitations, should not be exceeded. 3. Certain bonnet bolting material selections may require a CL600 easy-e valve assembly to be derated. Contact your Emerson sales office or Local Business Partner.</p>	

Description

The YD and YS valves are three-way valves for throttling or on-off (flow switching) service with converging (flow mixing) or diverging (flow splitting) flow patterns. YS valves, when used in diverging service, are recommended for on-off applications only. These valves are generally shipped as part of a control valve assembly, having a diaphragm, piston, or manual actuator mounted on them. A typical construction is shown in figure 1.

Specifications

Specifications for the YD and YS valves are shown in table 1. Some specifications appear on the actuator nameplate if the valve is part of a complete control valve assembly.

Educational Services

For information on available courses for Fisher YD and YS valves, as well as a variety of other products, contact:

Emerson Automation Solutions
Educational Services - Registration
Phone: 1-641-754-3771 or 1-800-338-8158
E-mail: education@emerson.com
emerson.com/fishervalvetraining

Installation

⚠ WARNING

Always wear protective gloves, clothing, and eyewear when performing any maintenance operations to avoid personal injury.

Personal injury or equipment damage caused by sudden release of pressure might result if the valve assembly is installed where service conditions could exceed the limits given in table 1 or on the appropriate nameplates. To avoid such injury or damage, provide a relief valve for overpressure protection as required by government or accepted industry codes and good engineering practices.

Check with your process or safety engineer for any additional measures that must be taken to protect against process media.

If installing into an existing application, also refer to the WARNING at the beginning of the Maintenance section in this instruction manual.

CAUTION

When ordered, the valve configuration and construction materials were selected to meet particular pressure, temperature, pressure drop, and controlled fluid conditions. Responsibility for the safety of process media and compatibility of valve materials with process media rests solely with the purchaser and end-user. Since some body/trim material combinations are limited in their pressure drop and temperature ranges, do not apply any other conditions to the valve without first contacting your [Emerson sales office](#) or Local Business Partner.

Before installing the valve, inspect the valve and pipelines for any damage and any foreign material which may cause product damage.

1. Before installing the valve, inspect it for any shipping damage and for any foreign material in the valve body cavity.
2. Clean out all pipelines to remove pipe scale, chips, welding slag, and other foreign materials.
3. Use accepted piping and welding practices when installing the valve. For flanged valves, use suitable gaskets between the valve and the pipeline flanges.
4. Do not install the valve in a system where the working pressures exceed those specified in the ASME pressure/temperature ratings or those specified by Emerson Automation Solutions.
5. If continuous operation is required during maintenance and inspection, install a conventional three-valve bypass around the valve so that the valve can be isolated.
6. Orient the valve so that flow will be in the direction indicated by the flow arrows.

Note

The common port for the YD is the bottom port as shown on the flow direction plates (key 17) in figure 10. The common port for the YS is the left-hand port as shown on the flow direction plates in figure 9.

CAUTION

Depending on valve body materials used, post weld heat treating may be required. If so, damage to internal elastomeric and plastic parts, as well as internal metal parts is possible. Threaded connections may also loosen. In general, if post weld

heat treating is to be performed, all trim parts should be removed. Contact your [Emerson sales office](#) or Local Business Partner for additional information.

7. YD or YS control valves can be installed in any position, although the recommended position is with the actuator vertical above the valve. For NPS 4 and 6 YS valves, size 80 or larger actuators mounted between 45 degrees above and 45 degrees below horizontal should be supported. If forces other than normal gravitational forces are experienced, such as vibrational forces, smaller size actuators might also need to be supported when they are not in a vertical position. For further information, consult your Emerson sales office or Local Business Partner.

Table 2. Valve Body Sizes and End Connections

VALVES SIZE, NPS	CAST IRON VALVES	STEEL OR STAINLESS STEEL VALVES
1/2, 3/4	---	NPT screwed or socket weld
1	---	NPT screwed; CL150, 300, or 600 raised-face or ring-type joint flanged; butt welding; or socket weld
1-1/2, 2	NPT screwed; CL125 flat-face flanged; or CL250 raised-face flanged	NPT screwed; CL150, 300, or 600 raised-face or ring-type joint flanged; butt welding; or socket weld
2-1/2, 3, 4, 6	CL125 flat-face or CL250 raised-face flanged	CL150, 300, or 600 raised face or ring-type joint flanged; or butt welding
8	---	CL150, 300, or 600 raised face, ring-type joint, or butt welding

⚠ WARNING

Personal injury could result from packing leakage. Valve packing was tightened before shipment; however, the packing might require some readjustment to meet specific service conditions. Check with your process or safety engineer for any additional measures that must be taken to protect against process media.

Valves with ENVIRO-SEAL live-loaded packing or HIGH-SEAL live-loaded packing will not require this initial re-adjustment. See the Fisher instruction manuals titled ENVIRO-SEAL Packing System for Sliding-Stem Valves or HIGH-SEAL Live-Loaded Packing System (as appropriate) for packing instructions. If you wish to convert your present packing arrangement to ENVIRO-SEAL packing, refer to the retrofit kits listed in the parts kit subsection near the end of this manual.

Maintenance

Valve parts are subject to normal wear and must be inspected and replaced as necessary. Inspection and maintenance frequency depends on the severity of service conditions. This section includes instructions for trim maintenance, packing maintenance, and ENVIRO-SEAL bellows seal bonnet replacement. All maintenance operations may be performed with the valve in the line.

⚠ WARNING

Avoid personal injury or property damage from sudden release of process pressure or uncontrolled movement of parts. Before performing any maintenance operations:

- Do not remove the actuator from the valve while the valve is still pressurized.
- Always wear protective gloves, clothing, and eyewear when performing any maintenance operations to avoid personal injury.
- Disconnect any operating lines providing air pressure, electric power, or a control signal to the actuator. Be sure the actuator cannot suddenly open or close the valve.

- Use bypass valves or completely shut off the process to isolate the valve from process pressure. Relieve process pressure from both sides of the valve. Drain the process media from both sides of the valve.
- Vent the power actuator loading pressure and relieve any actuator spring precompression.
- Use lock-out procedures to be sure that the above measures stay in effect while you work on the equipment.
- The valve packing box may contain process fluids that are pressurized, *even when the valve has been removed from the pipeline*. Process fluids may spray out under pressure when removing the packing hardware or packing rings, or when loosening the packing box pipe plug.
- Check with your process or safety engineer for any additional measures that must be taken to protect against process media.

CAUTION

Follow instructions carefully to avoid damaging the product surfaces, which could result in damage to the product.

Packing Lubrication

Figure 2. Lubricator and Lubricator/Isolating Valve (Optional)

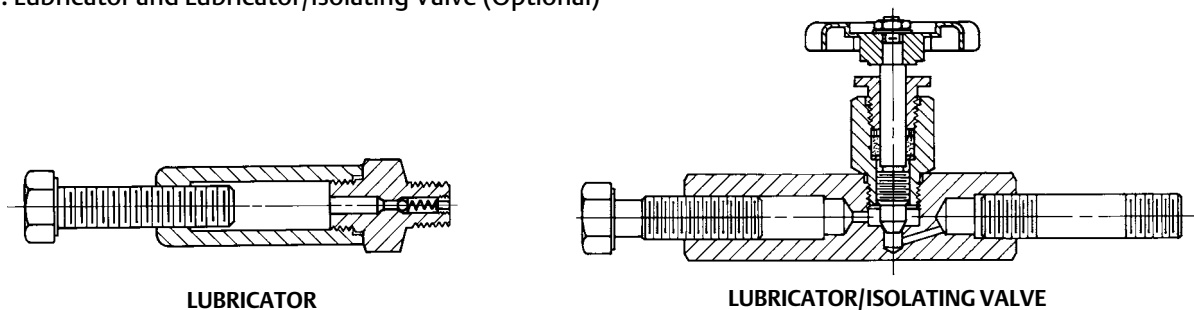

Note

ENVIRO-SEAL and HIGH-SEAL packing do not require lubrication.

⚠ WARNING

To avoid personal injury or property damage resulting from fire or explosion, do not lubricate packing used in oxygen service or in processes with temperatures over 260°C (500°F).

If a lubricator or lubricator/isolating valve (figure 2) is provided for PTFE/composition or other packings that require lubrication, it will be installed in place of the pipe plug (key 14, figure 13). Use a good quality silicon-base lubricant. Do not lubricate packing used in oxygen service or in processes with temperatures over 260°C (500°F). To operate the lubricator, simply turn the cap screw clockwise to force the lubricant into the packing box. The lubricator/isolating valve operates the same way except open the isolating valve before turning the cap screw and then close the isolating valve after lubrication is completed.

Packing Maintenance

Note

For valves with ENVIRO-SEAL packing, see the Fisher instruction manual ENVIRO-SEAL Packing System for Sliding-Stem Valves for packing instructions.

For valves with HIGH-SEAL packing, see the Fisher instruction manual HIGH-SEAL Live-Loaded Packing System for packing instructions.

Packing Replacement

⚠ WARNING

Observe the warning at the start of the Maintenance section.

Table 3. Recommended Torque for Packing Flange Nuts

VALVE STEM DIAMETER		PRESSURE RATING	GRAPHITE TYPE PACKING				PTFE TYPE PACKING			
			Minimum Torque		Maximum Torque		Minimum Torque		Maximum Torque	
mm	Inches		N•m	Lbf•in	N•m	Lbf•in	N•m	Lbf•in	N•m	Lbf•in
9.5	3/8	CL125, 150	3	27	5	40	1	13	2	19
		CL250, 300	4	36	6	53	2	17	3	26
		CL600	6	49	8	73	3	23	4	35
12.7	1/2	CL125, 150	5	44	8	66	2	21	4	31
		CL250, 300	7	59	10	88	3	28	5	42
		CL600	9	81	14	122	4	39	7	58
19.1	3/4	CL125, 150	11	99	17	149	5	47	8	70
		CL250, 300	15	133	23	199	7	64	11	95
		CL600	21	182	31	274	10	87	15	131
25.4	1	CL300	26	226	38	339	12	108	18	162
		CL600	35	310	53	466	17	149	25	223
31.8	1-1/4	CL300	36	318	54	477	17	152	26	228
		CL600	49	437	74	655	24	209	36	314

The following procedure covers PTFE V-ring packing. A similar procedure can be followed for PTFE/composition packing. However, because PTFE/composition packing comes in split rings, it is possible to replace the rings without removing the actuator from the valve.

Installation of graphite ribbon/filament packing requires special care to avoid trapping air between the rings. Start only one ring at a time without forcing the top of the packing ring below the bottom of the entrance chamfer of the packing box. Thus, when a ring is added, the stack should not be pushed into the cavity more than the thickness of the added ring.

The arrangement of packing box parts is shown in figures 3, 4, 5, 6, and 7. Key numbers used in the following steps are shown in figures 13 and 14.

1. Remove the actuator and bonnet according to steps 1 through 4 of the Disassembly procedure in the Maintenance section on page 7.
2. With the stem and valve plug assembly removed from the bonnet, remove the packing nuts (key 5), packing flange (key 3), wiper ring (key 12), and packing follower (key 13) from the bonnet. The old packing can then be pulled out with a packing hook (take care to avoid scratching the packing box wall) or pushed out using a rod inserted through the bottom of the bonnet.
3. Clean the packing box and all metal parts.
4. Complete maintenance necessary on other parts and install the bonnet on the valve as indicated in the Assembly section (starting on page 12).
5. Install the new packing and associated parts in the sequence shown in figures 3, 4, 5, 6, and 7. Be careful not to damage the packing during installation.
6. Replace the packing flange and packing flange nuts.

For **spring-loaded PTFE V-ring packing**, tighten the packing flange nuts until the shoulder on the packing follower contacts the bonnet.

For **graphite packing**, tighten the packing flange nuts to the maximum recommended torque shown in table 3. Then, loosen the packing flange nuts, and retighten them to the recommended minimum torque shown in table 3.

For **other packing types**, tighten the packing flange nuts alternately in small equal increments until one of the nuts reaches the minimum recommended torque shown in table 3. Then, tighten the remaining flange nut until the packing flange is level and at a 90-degree angle to the valve stem.

For **ENVIRO-SEAL or HIGH-SEAL live-loaded packing**, refer to the note at the beginning of the Packing Maintenance section.

7. Mount the actuator on the bonnet and make up the stem connection according to the procedure given in the appropriate actuator instruction manual.

Trim Maintenance

▲ WARNING

Observe the warning at the start of the Maintenance section.

CAUTION

To avoid damaging parts, do not grip the bellows shroud or other parts of the stem/bellows assembly. Grip only the flat areas on the stem where it extends out of the top of the bellows shroud.

Key numbers in the following procedures are shown in figure 10 for standard YD, in figure 11 for high-temperature YD, and in figure 9 for YS, except where indicated.

Disassembly

1. Isolate the control valve from the line pressure, release pressure from both sides of the valve, and drain the process media from both sides of the valve. Remove actuator supply pressure, and use lock-out procedures to be sure that the above measures stay in effect while you work on the equipment.

⚠ WARNING

See the **WARNING** at the beginning of the Maintenance section for more information.

- Disconnect the actuator stem connector and remove the locknut (key 15, figure 13) that holds the actuator to the valve. (Valves with a 127 mm (5-inch) yoke boss use cap screws and nuts to secure the actuator on the valve). Then lift the actuator from the valve.

Figure 3. Fisher PTFE V-Ring Packing Arrangements

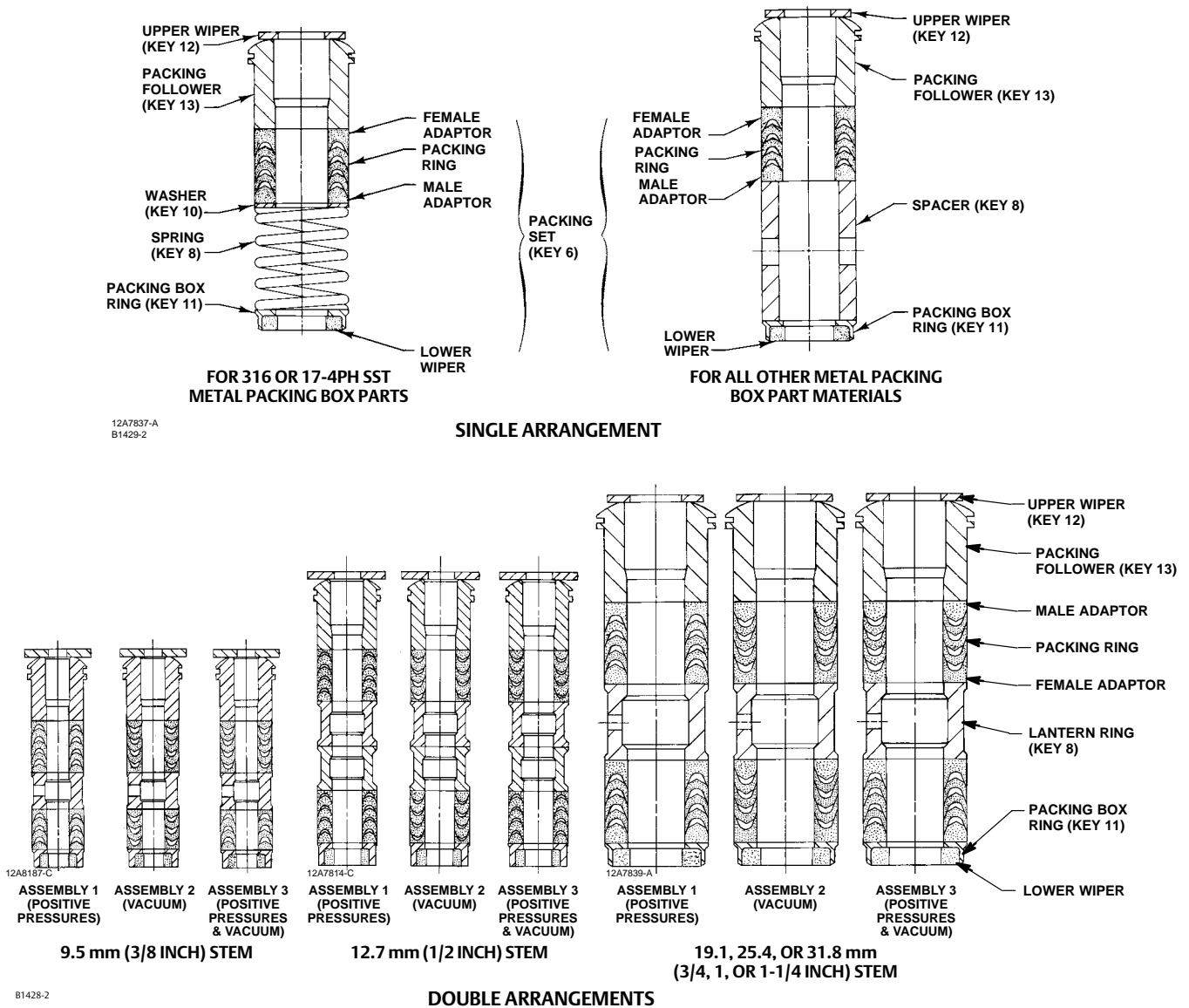
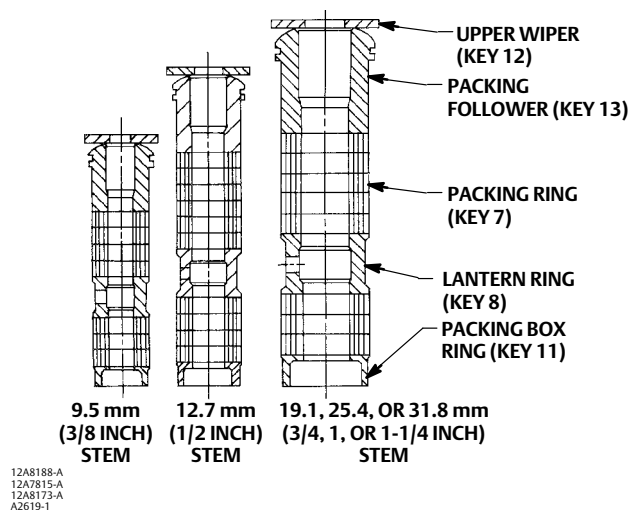
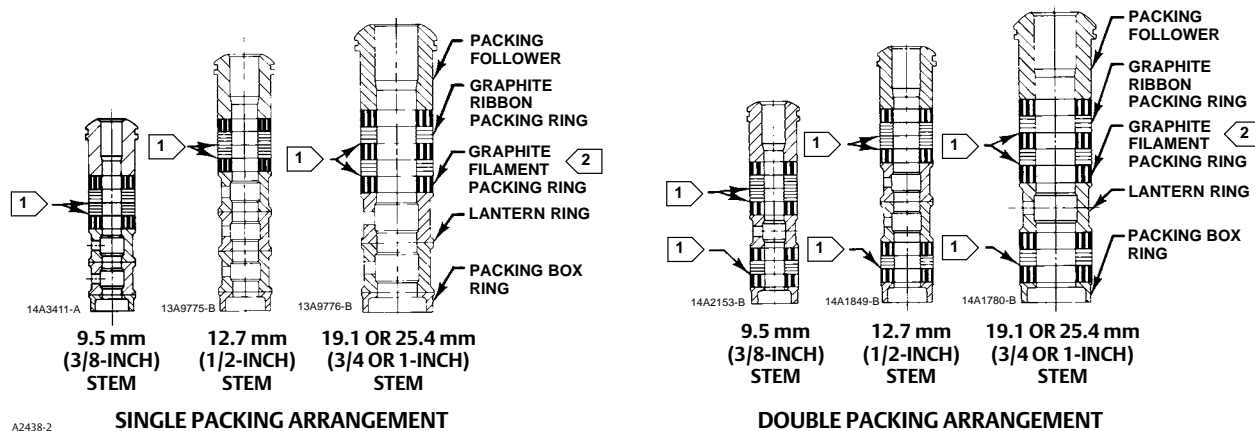

Figure 4. Detail of Fisher PTFE/Composition Packing Arrangements



TYPICAL (DOUBLE) ARRANGEMENTS

Figure 5. Fisher Graphite Ribbon/Filament Packing Arrangements



A2438-2

NOTE:

- 1 0.102 mm (0.004 INCH) THICK SACRIFICIAL ZINC WASHERS. USE ONLY ONE BELOW EACH GRAPHITE RIBBON RING.
- 2 HAS THE APPEARANCE OF A WOVEN OR BRAIDED RING.

Figure 6. PTFE Packing Arrangements for Use in Fisher ENVIRO-SEAL Bellows Seal Bonnets

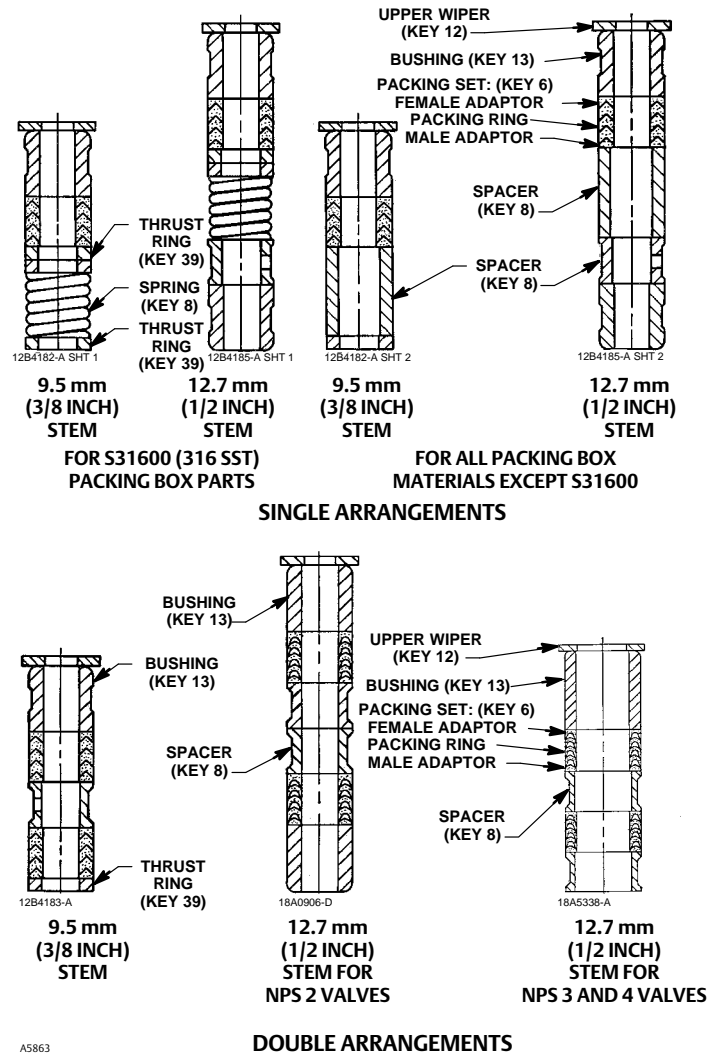

- Remove the nuts (key 16, figures 9 and 10) or cap screws from the bonnet flange.
- Lift off the bonnet along with the valve plug and stem (keys 2 and 5, figures 9 and 10). Due to the design of the valve, several other trim parts will be drawn out with the valve plug. They are as follows:
YD (Standard)--The upper cage (key 3A) and associated seals, gaskets, and shim (keys 9, 11, 19, 20A, 20B, and 22).
YD (High Temperature)--The upper cage (key 3B) and associated gaskets and shim (keys 9, 11, and 22).
YS--The upper seat (key 7), upper cage (key 3), and associated gaskets and shim (keys 9, 11, and 22).

CAUTION

The exposed portion of the cage provides a guiding surface that must not be damaged during disassembly or maintenance. Damage could affect valve performance. If the cage is stuck in the valve, use a rubber mallet to strike the exposed portion at several points around the circumference.

Figure 7. Double Graphite Ribbon/Filament Arrangements for Use in Fisher ENVIRO-SEAL Bellows Seal Bonnets

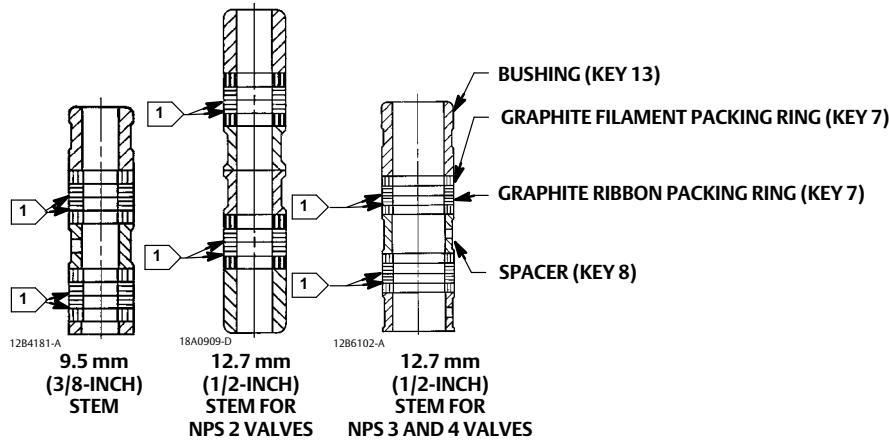

NOTE:
 1 0.102 mm (0.004 INCH) THICK SACRIFICIAL ZINC WASHERS;
 USE ONLY ONE BELOW EACH GRAPHITE RIBBON RING.

A5870

Take proper care not to damage any sealing or seating surfaces as nicks or scratches in these parts might cause leakage.

- Loosen the packing flange nuts (key 5, figures 13 and 14) and draw the valve plug and stem straight out the bottom of the bonnet. Lift all cage and seat parts off the valve plug and stem. If the stem for YD or YS requires replacing, drive the pin (key 6) out and unscrew the stem from the plug.

Table 4. Pin Drill Sizes

VALVE TYPE	VALVE STEM CONNECTION, mm (INCH)	DRILL SIZE, INCHES
YD & YS	9.5 (3/8)	3/32
	12.7 (1/2)	1/8
	19.1 (3/4)	3/16
	25.4 (1)	1/4

Table 5. Recommended Bolt Torques for B7 Body-to-Bonnet Bolting⁽¹⁾

VALVE SIZE, NPS	RECOMMENDED BOLT TORQUE, N•m (Lbf•ft)
1/2, 3/4	129 (95)
1, 1-1/2	129 (95)
2	96 (71)
2-1/2	96 (71)
3	169 (125)
4	271 (200)
6	549 (405)
8(2)	CL150/300: 373 (275) CL600: 522 (385)

1. For other materials, contact your [Emerson sales office](#) or Local Business Partner.
 2. For NPS 8 YD valves, the bottom adaptor has shorter bolts than the bonnet, but the bolt torque is the same as the bonnet torque.

- To replace the adaptor (key 24, figure 15) on ENVIRO-SEAL bellows seal bonnets, place the plug stem assembly and valve plug in a soft-jaw chuck or other type of vise so that the jaws grip a portion of the valve plug that is not a seating surface. Drive out the pin (key 36, figure 15). Reverse the plug stem assembly in the soft-jaw chuck or vise. Grip the flat areas on the valve stem just below the threads for the actuator/stem connection. Unscrew the valve plug/adaptor assembly (key 24, figure 15) from the valve stem assembly (key 20, figure 15).

CAUTION

Never use an old stem with a new valve plug. The use of an old stem requires drilling a new pin hole through the stem (or adaptor, in case an ENVIRO-SEAL bellows seal bonnet is being used). This drilling weakens the stem or adaptor and may cause failure in service. However, a used valve plug may be reused with a new stem or adaptor.

7. The internal parts of the bonnet can now be disassembled, if necessary. For packing replacement, refer to the section entitled Packing Replacement on page 6.
8. *Standard YD Only*—It is recommended that the cage seal (key 19), seal ring (key 20A), and backup ring (key 20B) be replaced upon assembly. These can be removed by prying them out of the upper cage grooves with a screwdriver or a soft-tipped instrument. If a screwdriver is used, take care not to scratch the surfaces of the cage.
9. The remaining trim parts can now be lifted out of the valve. Under severe service conditions, some of these parts might have become stuck to the valve. In this case, it might be necessary to use a seat ring puller to remove these parts. Because there is a slight clearance around the outer circumference of the lower cage (key 4) and seat ring (key 8), it might be possible to remove these by tapping them loose, if interior room permits.

Assembly

YD (Standard)

1. Use new gaskets, seals, and shim (keys 9, 11, 14, 19, 20A, 20B, and 22) on assembly and wipe all sealing surfaces with a clean cloth.
2. For NPS 8 YD, install the bottom flange adaptor (key 24) and gasket (key 9).
3. Install the seat ring gasket (key 14) and place the seat ring (key 8) on top of the gasket.
4. Install the lower cage (key 4) into the valve, being certain that it fits down over the raised portion of the seat ring. The narrow portion of the cage windows should point downward.
5. Slip the O-ring cage seal (key 19) over the bottom of the upper cage (key 3A) and into the cage groove.

Figure 8. Typical Bolting Pattern

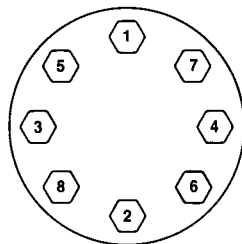

A0274-1

6. Press the backup ring (key 20B) and the seal ring (key 20A), respectively, into the inner groove of the upper cage. It might be necessary to bend one side of each of these in slightly to accomplish this. Take care not to distort the rings when doing this.
7. If a new stem (key 5) is to be used, screw the stem into the valve plug (key 2) until it wedges tight at the end of the valve stem thread.

CAUTION

Never use an old stem with a new valve plug. The use of an old stem requires drilling a new pin hole through the stem (or adaptor, in case an ENVIRO-SEAL bellows seal bonnet is being used). This drilling weakens the stem or adaptor and may cause failure in service. However, a used valve plug may be reused with a new stem or adaptor.

Locate the pilot hole in the valve plug and drill the hole through the plug and stem assembly (determine drill size from table 4). Drive in the pin to lock the assembly.

8. For ENVIRO-SEAL bellows seal bonnets, grip the flats of the stem extending out of the top of the bellows shroud with a soft-jaw chuck or other type of vise. Screw the valve plug/adaptor assembly onto the valve stem. Tighten as necessary to align the pin hole in the stem with one of the holes in the adaptor. Secure the adaptor to the stem with a new pin.

CAUTION

To prevent possible damage to the seal ring and cage seal, exercise care in the following procedure.

9. Place the upper cage (key 3A) over the plug assembly, being certain not to damage the seal ring, and lower this entire assembly into the valve. Due to the close fit between the valve body bore and the cage seal, it will be necessary to apply a steady force to the top of the cage for final positioning inside the valve body bore. Take care to ensure that the upper cage slips into the lower cage and the cage seal is not damaged.
10. Place the spiral wound gasket (key 11), shim (key 22), and bonnet gasket (key 9), respectively, over the upper cage.
11. Mount the bonnet onto the valve with the lubricator or pipe plug parallel with the pipeline.

Note

Stud(s) and nut(s) should be installed such that the manufacturer's trademark and material grade marking is visible, allowing easy comparison to the materials selected and documented in the Emerson/Fisher serial card provided with this product.

⚠ WARNING

Personal injury or damage to equipment could occur if improper stud and nut materials or parts are used. Do not operate or assemble this product with stud(s) and nut(s) that are not approved by Emerson/Fisher engineering and/or listed on the serial card provided with this product. Use of unapproved materials and parts could lead to stresses exceeding the design or code limits intended for this particular service. Install studs with the material grade and manufacturer's identification mark visible. Contact your Emerson Automation Solutions representative immediately if a discrepancy between actual parts and approved parts is suspected.

12. Lubricate the valve stud bolts or cap screws (key 15) and install the nuts (key 16) on the bolts using accepted bolting practices. Tighten the nuts to the recommended bolt torques given in table 5. Follow a pattern similar to that shown in figure 8.

Note

It might be necessary to repeat the bolting pattern several times until the bonnet-to-body seal is made, because the tightening of one nut might loosen an adjacent nut. Repeat the pattern until none of the nuts will turn at the recommended torque.

13. Mount the actuator on the bonnet and make up the stem connection according to the procedure given in the appropriate actuator instruction manual.

YD (High Temperature)

1. Use new gaskets, seals, and shim (keys 9, 11, 13, 14, 19, 20, and 22) on assembly and wipe all sealing surfaces with a clean cloth.
2. For NPS 8 YD, install the bottom flange adaptor (key 24) and gasket (key 9).
3. Install the seat ring gasket (key 14) and place the seat ring (key 8) on top of the gasket followed by the spiral wound spring (key 13).
4. Install the lower cage (key 4) into the valve, being certain that it fits down over the raised portion of the seat ring. The narrow portion of the cage windows should point downward.
5. Place one of the retaining ring gaskets (key 19) into the valve.
6. If a new stem (key 5) is to be used, screw the stem into the valve plug (key 2) until it wedges tight at the end of the valve stem thread.

CAUTION

Never use an old stem with a new valve plug. The use of an old stem requires drilling a new pin hole through the stem (or adaptor, in case an ENVIRO-SEAL bellows seal bonnet is being used). This drilling weakens the stem or adaptor and may cause failure in service. However, a used valve plug may be reused with a new stem or adaptor.

Locate the pilot hole in the valve plug and drill the hole through the plug and stem assembly (determine drill size from table 4). Drive in the pin to lock the assembly.

7. For ENVIRO-SEAL bellows seal bonnets, grip the flats of the stem extending out of the top of the bellows shroud with a soft-jaw chuck or other type of vise. Screw the valve plug/adaptor assembly onto the valve stem. Tighten as necessary to align the pin hole in the stem with one of the holes in the adaptor. Secure the adaptor to the stem with a new pin.
8. Place the seal ring retainer (key 3C) into the valve and lower the valve plug assembly into the retainer orifice.
9. Carefully place the seal rings (key 20) over the valve plug, being certain that they rest against the retaining ring. Each of these has a cut through its cross section. These cuts should be oriented 180 degrees apart to ensure a proper seal.
10. Insert the other retaining ring gasket (key 19) on top of the retaining ring.
11. Lower the upper cage (key 3B) into the valve. When properly installed, the raised ring on the bottom of the cage should fit snugly into the groove formed by the seal rings and the retaining ring.
12. Place the spiral wound gasket (key 11), shim (key 22), and bonnet gasket (key 9), respectively, over the upper cage.

-
13. Mount the bonnet onto the valve with the lubricator or pipe plug parallel with the pipeline.

Note

Stud(s) and nut(s) should be installed such that the manufacturer's trademark and material grade marking is visible, allowing easy comparison to the materials selected and documented in the Emerson/Fisher serial card provided with this product.

⚠ WARNING

Personal injury or damage to equipment could occur if improper stud and nut materials or parts are used. Do not operate or assemble this product with stud(s) and nut(s) that are not approved by Emerson/Fisher engineering and/or listed on the serial card provided with this product. Use of unapproved materials and parts could lead to stresses exceeding the design or code limits intended for this particular service. Install studs with the material grade and manufacturer's identification mark visible. Contact your Emerson representative immediately if a discrepancy between actual parts and approved parts is suspected.

14. Lubricate the valve stud bolts (key 15) and install the nuts (key 16) onto the bolts using good bolting practices. Tighten the nuts to the recommended bolt torques given in table 5. A pattern similar to that shown in figure 8 should be followed.

Note

It might be necessary to repeat the bolting pattern several times until the bonnet-to-body seal is made, because the tightening of one nut might loosen an adjacent nut. Repeat the pattern until none of the nuts will turn at the recommended torque.

15. Mount the actuator on the bonnet and make up the stem connection according to the procedure given in the appropriate actuator instruction manual.

YS

1. Use new gaskets and shim (keys 9, 11, 12, 13, 14 and 22) on assembly and wipe all sealing surfaces with a clean cloth.
2. Install the lower seat ring gasket (key 14) and place the lower seat ring (key 8) on top of the gasket followed by the spiral wound spring (key 13).
3. Install the lower cage (key 4) into the valve, being certain that it fits down over the raised portion of the seat ring. The narrow portion of the cage windows should point downward.
4. Place the upper seat ring gasket (key 12) into the valve.
5. If a new stem (key 5) is to be used, screw the stem into the valve plug (key 2) until it wedges tight at the end of the valve stem thread.

CAUTION

Never use an old stem with a new valve plug. The use of an old stem requires drilling a new pin hole through the stem (or adaptor, in case an ENVIRO-SEAL bellows seal bonnet is being used). This drilling weakens the stem or adaptor and may cause failure in service. However, a used valve plug may be reused with a new stem or adaptor.

Locate the pilot hole in the valve plug and drill the hole through the plug and stem assembly (determine drill size from table 4). Drive in the pin to lock the assembly.

6. For ENVIRO-SEAL bellows seal bonnets, grip the flats of the stem extending out of the top of the bellows shroud with a soft-jaw chuck or other type of vise. Screw the valve plug/adaptor assembly onto the valve stem. Tighten as necessary to align the pin hole in the stem with one of the holes in the adaptor. Secure the adaptor to the stem with a new pin.
7. Place the upper seat ring (key 7) and upper cage (key 3), respectively, over the plug and stem assembly, being certain not to scratch any sealing surfaces. Lower this entire assembly into the valve.
8. Place the spiral wound gasket (key 11), shim (key 22), and bonnet gasket (key 9), respectively, over the upper cage.
9. Mount the bonnet onto the valve with the lubricator or pipe plug parallel with the pipeline.

Note

Stud(s) and nut(s) should be installed such that the manufacturer's trademark and material grade marking is visible, allowing easy comparison to the materials selected and documented in the Emerson/Fisher serial card provided with this product.

⚠ WARNING

Personal injury or damage to equipment could occur if improper stud and nut materials or parts are used. Do not operate or assemble this product with stud(s) and nut(s) that are not approved by Emerson/Fisher engineering and/or listed on the serial card provided with this product. Use of unapproved materials and parts could lead to stresses exceeding the design or code limits intended for this particular service. Install studs with the material grade and manufacturer's identification mark visible. Contact your Emerson representative immediately if a discrepancy between actual parts and approved parts is suspected.

10. Lubricate the valve stud bolts or cap screws (key 15) and install the nuts (key 16) onto the bolts using good bolting practices. Tighten the nuts to the recommended bolt torques given in table 5. A pattern similar to that shown in figure 8 should be followed.

Note

It might be necessary to repeat the bolting pattern several times until the bonnet-to-body seal is made, because the tightening of one nut might loosen an adjacent nut. Repeat the pattern until none of the nuts will turn at the recommended torque.

11. Mount the actuator onto the bonnet and make up the stem connection according to the procedure given in the appropriate actuator instruction manual.

ENVIRO-SEAL Bellows Seal Bonnet

Replacing a Plain or Extension Bonnet with an ENVIRO-SEAL Bellows Seal Bonnet (Stem/Bellows Assembly)

1. Remove the actuator and bonnet according to steps 1 through 4 of the Disassembly procedure in the Maintenance section on page 7.
2. With care, remove the valve plug and stem assembly from the valve. If necessary, also lift out the cage.

CAUTION

To prevent possible product damage, cover the opening in the valve in the following procedure to protect the sealing surfaces and to prevent foreign material from getting into the valve body cavity.

3. Remove and discard the existing bonnet gasket. Cover the valve body opening to protect sealing surfaces and to prevent foreign material from entering the valve body cavity.

Note

The ENVIRO-SEAL stem/bellows assembly for YD and YS valves is available only with a threaded and drilled plug/adaptor/stem connection. The existing valve plug can be reused with the new stem/bellows assembly or a new plug can be installed.

4. Inspect the existing valve plug. If the plug is in good condition, it can be reused with the new ENVIRO-SEAL stem/bellows assembly. To remove the existing valve plug from the stem, first, place the existing plug stem assembly and valve plug in a soft-jaw chuck or other type of vise so that the jaws grip a portion of the valve plug that is not a seating surface. Drive out or drill out the pin (key 8).
5. Reverse the plug stem assembly in the soft-jaw chuck or vise. Grip the valve stem in an appropriate place and unscrew the existing plug from the valve stem.

CAUTION

When installing a valve plug on the ENVIRO-SEAL stem/bellows assembly, the valve stem must not be rotated. Damage to the bellows may result.

Do not grip the bellows shroud or other parts of the stem/bellows assembly. Grip only the flat areas on the stem where it extends out of the top of the bellows shroud.

Note

The ENVIRO-SEAL stem/bellows assembly has a one-piece stem.

6. To attach the valve plug to the stem of the new ENVIRO-SEAL stem/bellows assembly, first attach the plug to the adaptor (key 24). Locate the adaptor. Notice that a hole has not been drilled in the threads where the plug screws onto the adaptor. Secure the valve plug in a soft-jaw chuck or other type of vise. Do not grip the plug on any seating surface. Position the plug in the chuck or vise for easy threading of the adaptor. Thread the adaptor into the valve plug and tighten to the appropriate torque value.
7. Select the proper size of drill bit and drill through the adaptor using the hole in the valve plug as a guide. Remove any metal chips or burrs and drive in a new pin to lock the plug/adaptor assembly together.
8. Attach the plug/adaptor assembly to the ENVIRO-SEAL stem/bellows assembly by first securing the stem/bellows assembly in a soft-jaw chuck or other type of vise so that the jaws of the chuck or vise grip the flats of the stem extending out of the top of the bellows shroud. Screw the valve plug/adaptor assembly onto the valve stem. Tighten as necessary to align the pin hole in the stem with one of the holes in the adaptor. Secure the adaptor to the stem with a new pin.
9. Inspect the seat ring (key 9) and soft seat parts (keys 21, 22, and 23); replace, if necessary.
10. Place a new gasket (key 10) into the valve in place of the bonnet gasket. Install the new stem/bellows assembly with valve plug/adaptor by placing it into the valve on top of the new bellows gasket.

11. Place a new gasket (key 22) over the stem/bellows assembly. Place the new ENVIRO-SEAL bonnet over the stem/bellows assembly.

Note

Stud(s) and nut(s) should be installed such that the manufacturer's trademark and material grade marking is visible, allowing easy comparison to the materials selected and documented in the Emerson/Fisher serial card provided with this product.

⚠ WARNING

Personal injury or damage to equipment could occur if improper stud and nut materials or parts are used. Do not operate or assemble this product with stud(s) and nut(s) that are not approved by Emerson/Fisher engineering and/or listed on the serial card provided with this product. Use of unapproved materials and parts could lead to stresses exceeding the design or code limits intended for this particular service. Install studs with the material grade and manufacturer's identification mark visible. Contact your Emerson representative immediately if a discrepancy between actual parts and approved parts is suspected.

12. Properly lubricate the bonnet stud bolts. Install and tighten the bonnet hex nuts to the proper torque.
13. Install new packing and the metal packing box parts according to the appropriate arrangement in figure 17 or 18.
14. Install the packing flange. Properly lubricate the packing flange stud bolts and the faces of the packing flange nuts.

For **graphite packing**, tighten the packing flange nuts to the maximum recommended torque shown in table 6. Then, loosen the packing flange nuts, and retighten them to the recommended minimum torque shown in table 6.

For **other packing types**, tighten the packing flange nuts alternately in small equal increments until one of the nuts reaches the minimum recommended torque shown in table 6. Then, tighten the remaining flange nut until the packing flange is level and at a 90-degree angle to the valve stem.

15. Install travel indicator parts and stem locknuts; mount the actuator onto the valve according to the procedure in the appropriate actuator instruction manual.

Replacement of an Installed ENVIRO-SEAL Bellows Seal Bonnet (Stem/Bellows Assembly)

1. Remove the actuator and bonnet according to steps 1 through 4 of the Disassembly procedure in the Maintenance section on page 7.

CAUTION

To prevent possible product damage, cover the opening in the valve in the following procedure to protect the sealing surfaces and to prevent foreign material from getting into the valve body cavity.

2. Carefully remove the ENVIRO-SEAL stem/bellows assembly. If necessary, also lift out the cage. Remove and discard the existing bonnet gasket and bellows gasket. Cover the valve body opening to protect sealing surfaces and to prevent foreign material from entering the valve body cavity.

CAUTION

The ENVIRO-SEAL stem/bellows assembly for YD and YS valves is available only with a threaded and drilled plug/adaptor/stem connection. The existing valve plug can be reused with the new stem/bellows assembly or a new plug

can be installed. If the existing valve plug is reused, and the adaptor is in good condition, it may also be reused. However, never reuse an old adaptor with a new valve plug. Using an old adaptor with a new valve plug requires drilling a new pin hole in the adaptor. This drilling weakens the adaptor and may cause failure in service. However, a used valve plug may be reused with a new adaptor.

3. Inspect the existing valve plug and adaptor. If they are in good condition, they can be reused with the new stem/bellows assembly and they do not need to be separated.

CAUTION

When removing/installing a valve plug on the ENVIRO-SEAL stem/bellows assembly, the valve stem must not be rotated. Damage to the bellows may result.

Do not grip the bellows shroud or other parts of the stem/bellows assembly. Grip only the flat areas on the stem where it extends out of the top of the bellows shroud.

Note

The ENVIRO-SEAL stem/bellows assembly has a one-piece stem.

4. If the valve plug and adaptor are not in good condition and must be replaced, first remove the valve plug/adaptor assembly from the stem/bellows assembly; then remove the valve plug from the adaptor. First, place the stem/bellows assembly and valve plug in a soft-jaw chuck or other type of vise so that the jaws grip a portion of the valve plug that is not a seating surface. Drive out or drill out the pin (key 6, figure 9, 10, or 11. Drive out the pin (key 36, figure 15).

Table 6. Recommended Torque for Fisher ENVIRO-SEAL Bellows Seal Packing Flange Nuts

VALVE SIZE, NPS	VALVE STEM DIAMETER THROUGH PACKING	MINIMUM TORQUE		MAXIMUM TORQUE	
		N•m	Lbf•in	N•m	Lbf•in
1/2 - 2	1/2	3	24	5	48
3 - 4	1	7	60	10	84

5. Reverse the stem/bellows and plug/adaptor assembly in the soft-jaw chuck or vise. Grip the flat areas on the valve stem just below the threads for the actuator/stem connection. Unscrew the plug/adaptor assembly from the stem/bellows assembly. Unscrew the valve plug from the adaptor.
6. To attach either the existing valve plug or a new one to the stem of the new ENVIRO-SEAL stem/bellows assembly, first attach the plug to the adaptor (if the valve plug was removed from the adaptor) as follows:
 - Locate the adaptor. Notice that a hole has not been drilled in the threads where the plug screws onto the adaptor.
 - Secure the valve plug in a soft-jaw chuck or other type of vise. Do not grip the plug on any seating surface. Position the plug in the chuck or vise for easy threading of the adaptor.
 - Thread the adaptor into the valve plug and tighten to the appropriate torque value.
7. Complete the installation by following steps 7 through 9 and steps 12 through 15 of the ENVIRO-SEAL Bellows Seal Bonnet installation instructions given above.

Purging the ENVIRO-SEAL Bellows Seal Bonnet

The ENVIRO-SEAL bellows seal bonnet can be purged or leak tested. Refer to figure 15 for an illustration of an ENVIRO-SEAL bellows seal bonnet, and perform the following steps for purging or leak testing.

1. Remove the two diametrically opposed pipe plugs (key 16).
2. Connect a purging fluid to one of the pipe plug connections.
3. Install appropriate piping or tubing in the other pipe plug connection to pipe away the purging fluid or to make a connection to an analyzer for leak testing.

Figure 9. Fisher YS Valve

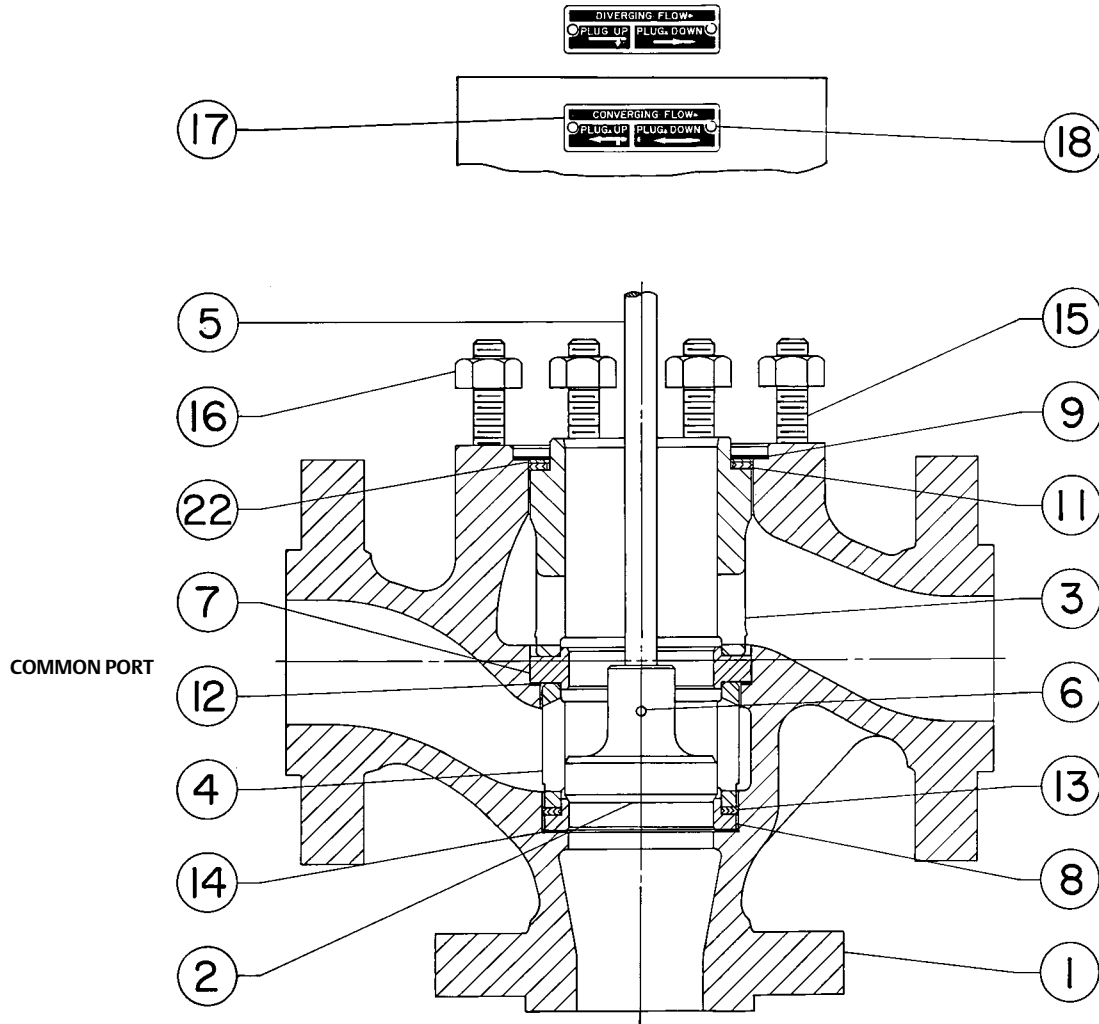

30A3554-D

Figure 10. Fisher YD Valve (Standard)

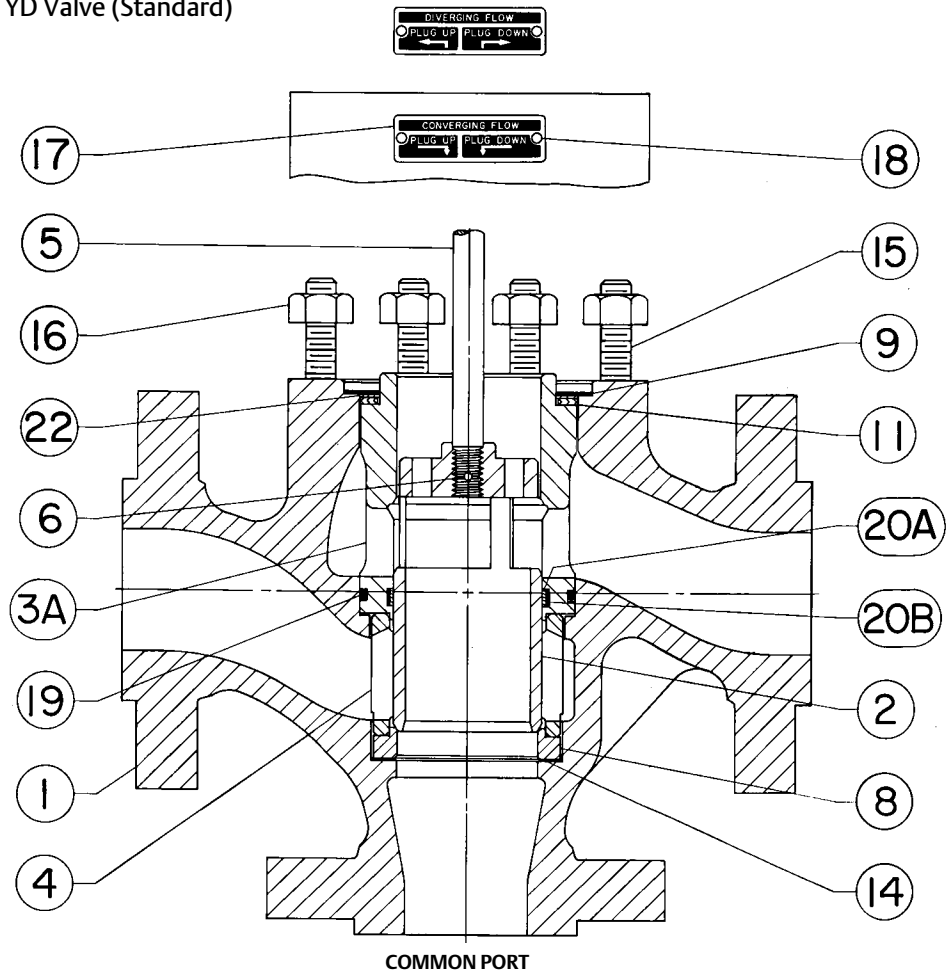

40A3552-F

Figure 11. Fisher YD Valve (High Temperature)

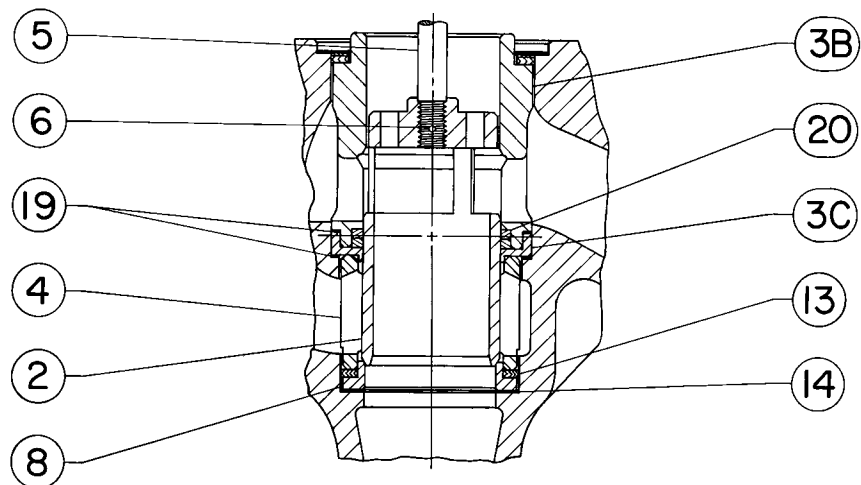

40A3552-F

Figure 12. Fisher NPS 8 YD Valve

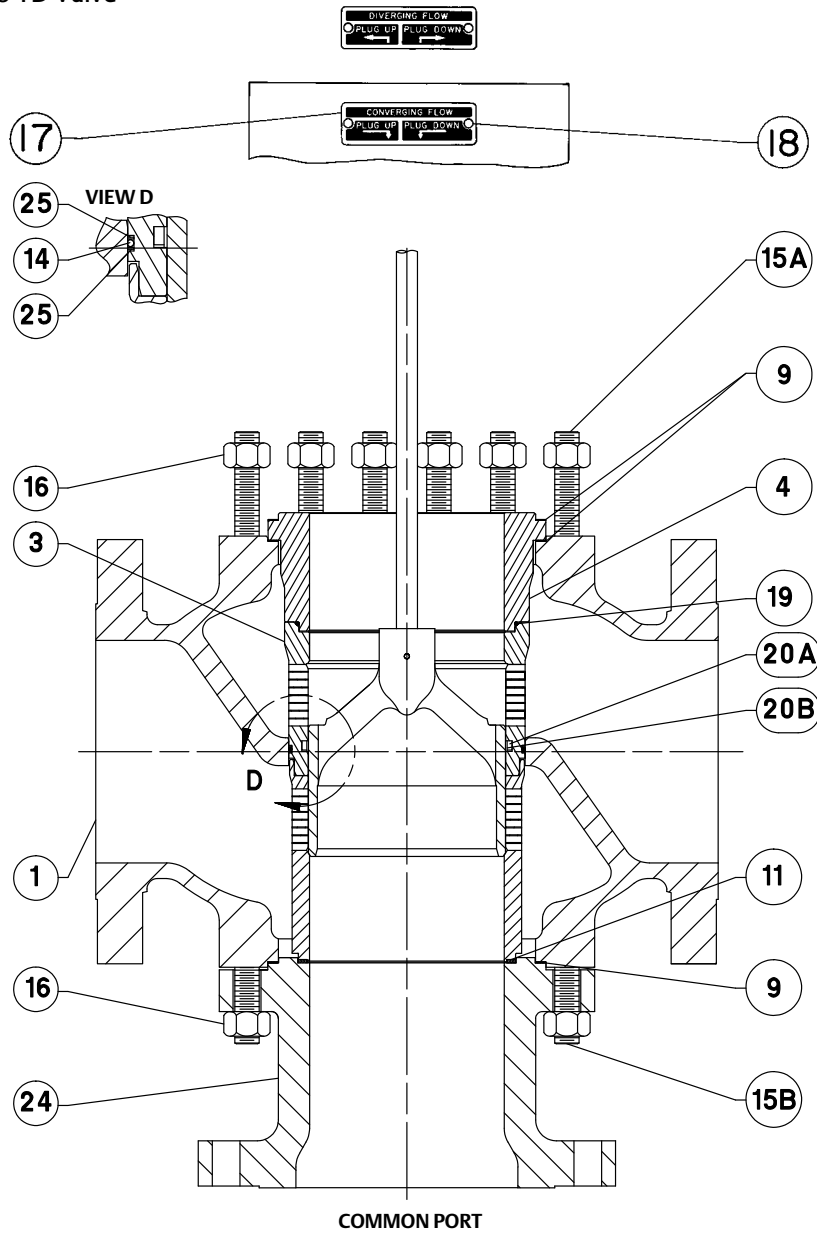

5489114-A

Figure 13. Fisher Standard Bonnet

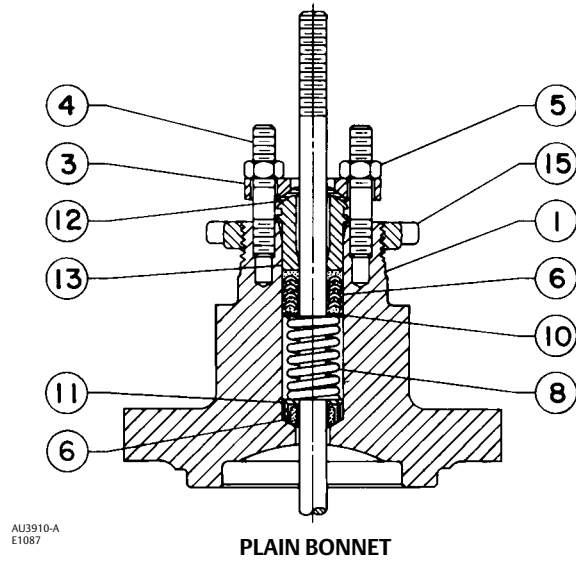

AU3910-A
E1087

Figure 14. Fisher Extension Bonnet

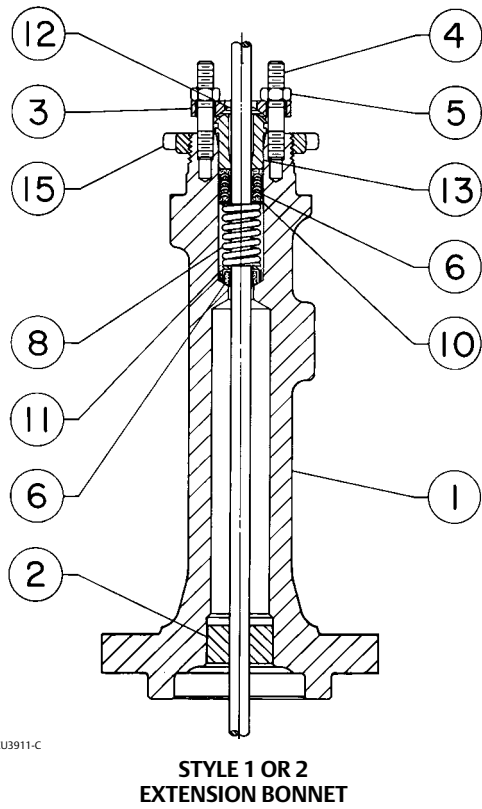

CU3911-C

Figure 15. Fisher ENVIRO-SEAL Bellows Seal Bonnet

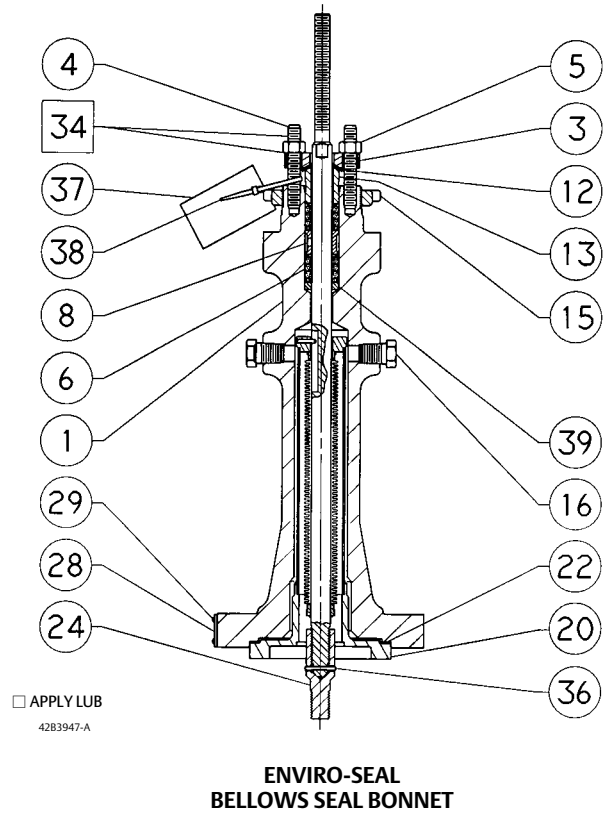

□ APPLY LUB
42B3947-A

Parts Ordering

Each valve is assigned a serial number which can be found on the valve. This same number also appears on the actuator nameplate when the valve is shipped from the factory as part of a control valve assembly. Always refer to the serial number when corresponding with your [Emerson sales office](#) or Local Business Partner about this equipment. When ordering replacement parts, also state the complete eleven-character part number for each part required from the following parts list.

⚠ WARNING

Use only genuine Fisher replacement parts. Components that are not supplied by Emerson Automation Solutions should not, under any circumstances, be used in any Fisher valve, because they may void your warranty, might adversely affect the performance of the valve, and could cause personal injury and property damage.

Parts Kits

Standard Packing Repair Kits (Non Live-Loaded)

Stem Diameter, mm (Inches) Yoke Boss Diameter, mm (Inches)	9.5 (3/8) 54 (2-1/8)	12.7 (1/2) 71 (2-13/16)	19.1 (3/4) 90 (3-9/16)	25.4 (1) 127 (5)
PTFE (Contains keys 6, 8, 10, 11, and 12)	RPACKX00012	RPACKX00022	RPACKX00032	RPACKX00342
Double PTFE (Contains keys 6, 8, 11, and 12)	RPACKX00042	RPACKX00052	RPACKX00062	RPACKX00362
PTFE/Composition (Contains keys 7, 8, 11, and 12)	RPACKX00072	RPACKX00082	RPACKX00092	---
Single Graphite Ribbon/Filament (Contains keys 7 [ribbon ring], 7 [filament ring], 8, and 11)	RPACKX00102	RPACKX00112	RPACKX00122	---
Single Graphite Ribbon/Filament (Contains keys 7 [ribbon ring], 7 [filament ring], and 11)	---	---	---	RPACKX00532
Single Graphite Ribbon/Filament (Contains keys 7 [ribbon ring], 7 [filament ring])	RPACKX00132	RPACKX00142	RPACKX00152	---
Double Graphite Ribbon/Filament (Contains keys 7 [ribbon ring], 7 [filament ring], 8, and 11)	RPACKX00162	RPACKX00172	RPACKX00182	---

Packing Kits (ENVIRO-SEAL) Repair

PACKING MATERIAL	STEM DIAMETER AND YOKE BOSS DIAMETER, mm (INCH)			
	9.5 (3/8) 54 (2-1/8)	12.7 (1/2) 71 (2-13/16)	19.1 (3/4) 90 (3-9/16)	25.4 (1) 127 (5)
Double PTFE (contains keys 214, 215, & 218)	RPACKX00192	RPACKX00202	RPACKX00212	RPACKX00222
Graphite ULF (contains keys 207, 208, 209, 210, and 214)	RPACKX00592	RPACKX00602	RPACKX00612	RPACKX00622

Packing Kits (ENVIRO-SEAL) Retrofit

PACKING MATERIAL	STEM DIAMETER AND YOKE BOSS DIAMETER, mm (INCH)			
	9.5 (3/8) 54 (2-1/8)	12.7 (1/2) 71 (2-13/16)	19.1 (3/4) 90 (3-9/16)	25.4 (1) 127 (5)
Double PTFE (contains keys 200, 201, 211, 212, 214, 215, 217, and 218)	RPACKXRT012	RPACKXRT022	RPACKXRT032	RPACKXRT042
Graphite ULF (contains keys 200, 201, 207, 208, 209, 210, 211, 212, 214, and 217)	RPACKXRT262	RPACKXRT272	RPACKXRT282	RPACKXRT292

Gasket Kits

Gasket Kits

VALVE SIZE, NPS	YD (Includes keys 9, 11, 14, and 22)	YS (Includes keys 9, 11, 12, 13, 14, and 22)
	Part Number	Part Number
NPS 1/2 to 1-1/2 NPS 2 to 2-1/2 NPS 3 NPS 4 NPS 6	RGASKETXB62 RGASKETXB72 RGASKETXB82 RGASKETXB92 RGASKETXC12	RGASKETXC22 RGASKETXC32 RGASKETXC42 RGASKETXC52 RGASKETXC62

Valve Size, NPS	Key Number	YD Part Number	YS Part Number
1/2 through 1-1/2	Set	RGASKETXB62	RGASKETXC22
	9	1R2859X0042	1R2859X0042
	11	1R286099442	1R286099442
	12	---	10A3326X052
	13	---	10A3325X062
	14	10A3327X052	10A3327X052
	22	16A1936X012	16A1936X012
2 through 2-1/2	Set	RGASKETXB72	RGASKETXC32
	9	1R3299X0042	1R3299X0042
	11	1R329799442	1R329799442
	12	---	10A3384X042
	13	---	10A3383X042
	14	10A3385X042	10A3385X042
	22	16A1938X012	16A1938X012
3	Set	RGASKETXB82	RGASKETXC42
	9	1R3484X0042	1R3484X0042
	11	1R348299442	1R348299442
	12	---	10A3437X062
	13	---	10A3436X042
	14	10A3438X062	10A3438X062
	22	16A1940X012	16A1940X012
4	Set	RGASKETXB92	RGASKETXC52
	9	1R3724X0042	1R3724X0042
	11	1R372299442	1R372299442
	12	---	10A3479X052
	13	---	10A3478X052
	14	10A3480X052	10A3480X052
	22	16A1941X012	16A1941X012
6	Set	RGASKETXC12	RGASKETXC62
	9	1U5081X0052	1U5081X0052
	11	1U508599442	1U508599442
	12	---	10A3525X042
	13	---	10A3524X022
	14	11A9521X052	11A9521X052
	22	16A1942X012	16A1942X012

Figure 16. Typical Fisher HIGH-SEAL Graphite ULF Packing System

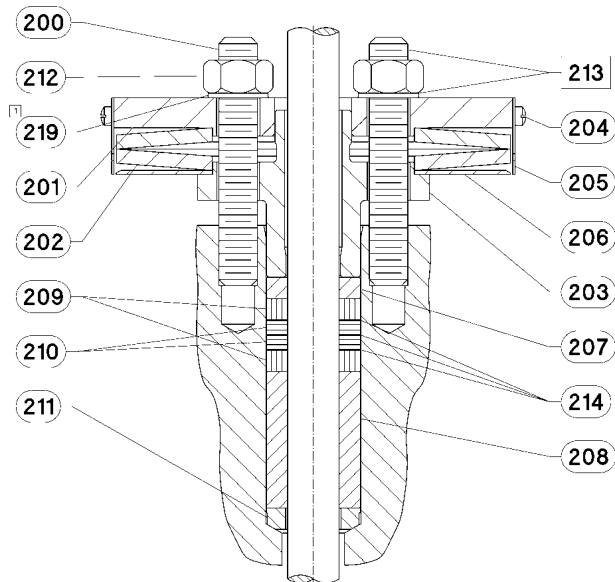

1. FIND NUMBER 219 NOT REQUIRED WITH 3/8 INCH STEM

39B4153-A

Figure 17. Typical Fisher ENVIRO-SEAL Packing System with PTFE Packing

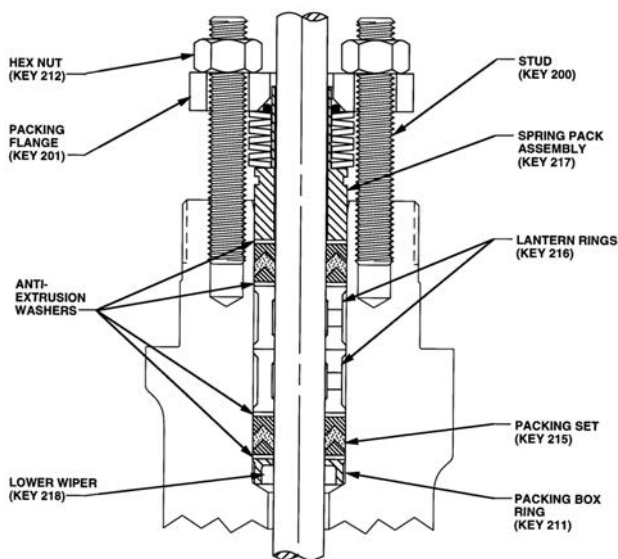

A6297-1

Figure 18. Typical Fisher ENVIRO-SEAL Packing System with Graphite ULF Packing

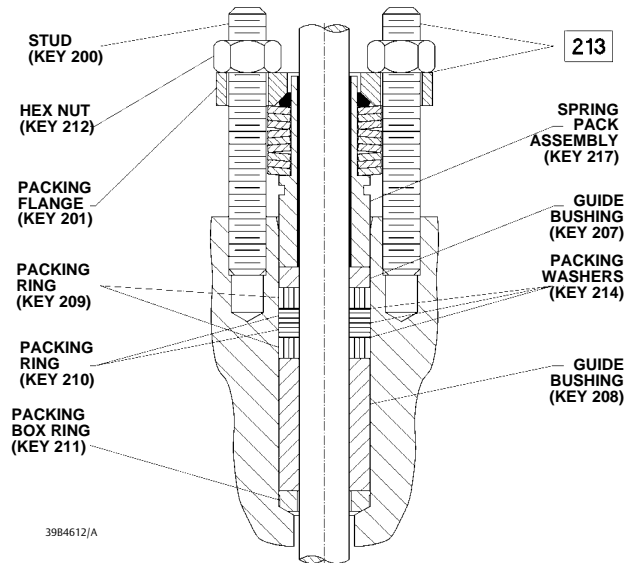

39B4612/A

Parts List

Note

Part numbers are shown for recommended spares only. For part numbers not shown, contact your [Emerson sales office](#) or Local Business Partner.

Note

Part numbers for most key numbers are listed in tables which follow.

YD and YS Valve

Key	Description	Part Number
1	If you need a valve body as a replacement part, order by valve size, serial number, and desired material	
17	Flow Direction Plate, SST	
18	Drive Screw, SST (4 req'd)	
21	Nameplate	
23	Wire	

Bonnet for YD and YS

1	Bonnet If you need a bonnet as a replacement part, order by valve size and stem diameter, serial number, and desired material.	
14	Pipe Plug	
16	Pipe Plug (Used With Tapped Extension Bonnet Only) (not shown)	
27	Pipe Nipple (Used with Lubr./Iso. Valve)	

*Recommended spare parts

Keys 2*, 5*, and 6* Valve Plug and Stem Assembly for Plain Bonnet

VALVE SIZE, NPS	STEM DIAMETER & VSC SIZE		YD STANDARD		YD HIGH TEMPERATURE		YS	
	mm	Inches	CB7Cu-1 (17-4PH SST)	CF8M (316 SST)	CB7Cu-1 (17-4PH SST)	CF8M (316 SST)	S41600 (416 SST)	S31600 (316 SST)
1/2 to 1-1/2	9.5 12.7	3/8 1/2	10A3315X032 ---	10A3315X052 ---	---	---	10A3317X202 10A9499X092	10A3317X072 ---
2 and 2-1/2	12.7	1/2	20A3369X052	20A3369X122	21A5078X032	---	10A3373X242	10A3373X232
3	12.7 19.1	1/2 3/4	20A3422X102 ---	20A3422X072 ---	---	---	10A3427X052 10A3428X102	10A3427X112 ---
4	12.7	1/2	20A3464X092	20A3464X072	---	---	20A3469X102	---
6	19.1	3/4	20A3507X092	20A3507X112	21A5073X062	---	20A3511X092	20A3511X082

Key 2* Valve Plug

VALVE SIZE, NPS	VALVE STEM CONNECTION		YD STANDARD		YD HIGH-TEMPERATURE	
	mm	Inch	CB7Cu-1 (17-4 PH SST)	CF8M (316 SST)	CB7Cu-1 (17-4 PH SST)	CF8M (316 SST)
1/2 to 1-1/2	9.5	3/8	10A3315X012	10A3315X022	11A5077X012	---
2 & 2-1/2	12.7	1/2	20A3369X012	20A3369X022	21A5078X012	21A5078X022
3	12.7 19.1	1/2 3/4	20A3422X092 20A3423X052	20A3422X022 ---	21A5071X042 21A5072X052	21A5071X022 ---
4	12.7 19.1	1/2 3/4	20A3464X082 20A3465X042	20A3464X022 20A3465X022	21A5076X042 21A5075X042	21A5076X022 21A5075X022
6	19.1 25.4	3/4 1	20A3507X042 20A3508X042	20A3507X022 ---	21A5073X052 21A5074X042	21A5073X022 ---

Key 2* Valve Plug (cont.)

VALVE SIZE, NPS	VALVE STEM CONNECTION		YS	
	mm	Inch	S41600 (416 SST)	S31600 (316 SST)
1/2 to 1-1/2	9.5 12.7	3/8 1/2	10A3317X012 10A9499X012	10A3317X022 10A9499X022
2 & 2-1/2	12.7 19.1	1/2 3/4	10A3373X012 ---	10A3373X022 10A3374X022
3	12.7 19.1	1/2 3/4	10A3427X012 10A3428X012	10A3427X022 10A3428X022
4	12.7 19.1	1/2 3/4	20A3469X012 20A3470X012	20A3469X022 20A3470X022
6	19.1 25.4	3/4 1	20A3511X012 20A3512X012	20A3511X022 20A3512X022

Keys 3* & 3A* Upper Cage (YS and Standard YD Only)

VALVE SIZE, NPS	KEY 3, UPPER CAGE (YS)		KEY 3A, UPPER CAGE (YD STANDARD)	
	CB7Cu-1 (17-4PH SST)	CF8M (316 SST), ENC	CB7Cu-1 (17-4PH SST)	CF8M (316 SST), ENC
1/2 - 1-1/2 2, 2-1/2	29A7516X012 2U223433272	29A7516X022 2U740448932	20A3363X012 20A3376X012	30A3319X022 30A3377X012
3	2U231833272	2U740648932	20A3431X012	30A3432X012
4	2U236033272	2U740748932	20A3473X012	30A3474X012
6	2U506333272	2U806948932	20A3516X012	30A3517X012

Keys 3B*, 3C*, & 4* Upper Cage and Retaining Ring (High Temp. YD Only) and Lower Cage

VALVE SIZE, NPS	KEY 3B, UPPER CAGE (YD HIGH TEMPERATURE)		KEY 3C, RETAINING RING (YD HIGH TEMPERATURE)		KEY 4, LOWER CAGE (ALL TRIM STYLES)	
	CB7Cu-1 (17-4PH SST)	CF8M (316 SST), ENC	S41600 (416 SST)	CF8M (316 SST)	CB7Cu-1 (17-4PH SST)	CF8M (316 SST), ENC
1/2 - 1-1/2 2, 2-1/2	20A3320X012 20A3378X012	---	10A3337X012 10A3394X012	---	20A3323X012 20A3381X012	20A3324X012 20A3382X012
3	20A3546X012	30A3547X012	10A3344X012	10A3348X022	20A3434X012	20A3435X012
4	20A3548X012	30A3549X012	10A3490X012	10A3490X012	20A3476X012	20A3477X012
6	20A3518X012	30A3519X012	10A3536X012	10A3536X022	20A3522X012	20A3523X012

*Recommended spare parts

Key 5* Valve Plug Stem

VALVE SIZE, NPS	STEM SIZE		VALVE STEM CONNECTION		YD, S31600 (316 SST)		YS, S31600 (316 SST)	
	mm	Inch	mm	Inch	Standard Bonnet	Style 1 Ext. Bonnet	Standard Bonnet	Style 1 Ext. Bonnet
For Use With Group 1 Actuators⁽¹⁾								
1/2 thru 1-1/2	9.5	3/8	9.5	3/8	10A8823X312	1U217735162	10A8823X292	10A3539X012
	12.7	1/2	9.5	3/8	1U530935162	---	---	---
2, 2-1/2	12.7	1/2	12.7	1/2	10A3541X012	10A3540X012	1N821035162	1U218035162
	19.1	3/4	12.7	1/2	---	---	---	---
3	12.7	1/2	12.7	1/2	1U230535162	1U230635162	1U217935162	1U7965X0012
	19.1	3/4	19.1	3/4	1U230835162	---	1K5878X0012	---
4	12.7	1/2	12.7	1/2	1K586935162	1U230635162	1U230635162	1U294035162
	19.1	3/4	19.1	3/4	1K587735162	---	1K896535162	1P669735162
6	19.1	3/4	19.1	3/4	1L996435162	1U507135162	1U507135162	1P669735162
For Use With Group 100 Actuators⁽¹⁾								
6	25.4	1	25.4	1	---	---	1K928935162	---
For Use With Group 101 Actuators⁽¹⁾								
6	25.4	1	25.4	1	---	---	1K744735162	---

1. Actuator Groups 1, 100, and 101 are defined on the following page.

Actuator Groups

GROUP 1 54, 71, 90 mm (2-1/8, 2-13/16 & 3-9/16 INCH) YOKE BOSS	GROUP 100 127 mm (5-Inch) YOKE BOSS
585C Series 1B 644 & 645 655 657 & 667—Except 102 mm (4-Inch) Travel, Size 70 1008—Except 51 mm (2-Inch) Travel, 90 mm (3-9/16 Inch) Yoke Boss	585C Series 657 1008—51 mm (2-Inch) only
	Group 101 127 mm (5-Inch) Yoke Boss
	667

Key 6* Pin, 316 SST

VALVE SIZE, NPS	VALVE STEM CONNECTION		YD	YS
	mm	Inch		
1/2 to 1-1/2	9.5	3/8	1P730438992	1P730438992
	12.7	1/2	---	1B627035072
2 & 2-1/2	12.7	1/2	1B599635072	1B599635072
	19.1	3/4	---	1R7386X0012
3	12.7	1/2	1B599635072	1B599635072
	19.1	3/4	1R7386X0012	1R7386X0012
4	12.7	1/2	1D545735072	1D545735072
	19.1	3/4	1D5458X0012	1D5458X0012
6	19.1	3/4	1B600735072	1L302335072
	25.4	1	1R655435072	---

Keys 7* & 8* Upper and Lower Seat Rings

VALVE SIZE, NPS	KEY 7, UPPER SEAT RING		KEY 8, LOWER SEAT RING			
	YS		YD Standard		YD High Temperature and YS	
	S41600 (416 SST)	S31600 (316 SST)	S41600 (416 SST)	CF8M (316 SST)	S41600 (416 SST)	CF8M (316 SST)
1/2, 3/4, 1, 1-1/2	10A3336X012	10A3336X022	10A3335X012	10A3335X022	10A3334X012	10A3334X022
2, 2-1/2	---	10A3393X022	10A3392X012	10A3392X022	10A3391X012	10A3391X022
	10A3447X012	10A3447X022	10A3446X012	10A3446X022	10A3445X012	10A3445X022
3	10A3489X012	10A3489X022	10A3488X012	10A3488X022	10A3487X012	10A3487X022
4	10A3535X012	10A3535X022	11A9076X012	11A9076X022	10A3533X012	10A3533X022

Key 9* Bonnet Gasket and Key 22* Shim

VALVE SIZE, NPS	KEY 9 (YD & YS)	KEY 22 (YD & YS)
	FGM (Graphite/S31600)	S31600 (316 SST)
1/2 - 1-1/2	1R2859X0042	16A1936X012
2, 2-1/2 3	1R3299X0042 1R3484X0042	16A1938X012 16A1940X012
4 6	1R3724X0042 1U5081X0052	16A1941X012 16A1942X012

Key 11* Spiral Wound Gasket and Key 13* Spiral Wound Spring

VALVE SIZE, NPS	KEY 11 (YD & YS)	KEY 13 (YS ONLY)
	N06600 and Graphite Laminate	N06600 and Graphite Laminate
	To 593°C (1100°F)	To 593°C (1100°F)
1/2 - 1-1/2	1R286099442	10A3325X062
2, 2-1/2 3	1R329799442 1R348299442	10A3383X042 10A3436X042
4 6	1R372299442 1U508599442	10A3478X052 10A3524X022 ⁽¹⁾

1. N06600 material only.

Key 12* Upper Seat Ring Gasket and Key 14* Lower Seat Ring Gasket

VALVE SIZE, NPS	KEY 12 (YS ONLY)	KEY 14 (YD & YS)
	FGM (Graphite/S31600)	FGM (Graphite/S31600)
1/2 - 1-1/2	10A3326X052	10A3327X052
2, 2-1/2 3	10A3384X042 10A3437X062	10A3385X042 10A3438X062
4 6	10A3479X052 10A3525X042	10A3480X052 11A9521X052

Key 19* O-Ring or Gasket (YD Only)

VALVE SIZE, NPS	O-RING (YD STANDARD)			RETAINING RING GASKET (YD HIGH TEMPERATURE) (2 REQ'D)
	Nitrile ⁽¹⁾ -29 to 93°C (-20 to 200°F)	Fluorocarbon ⁽²⁾ -18 to 204°C (0 to 400°F)	Ethylene-Propylene -40 to 232°C (-40 to 450°F)	FGM (Graphite/S31600)
1/2, 3/4, 1, 1-1/2	10A3328X012	10A3330X012	10A3329X022	10A3326X052
2, 2-1/2 3	1V3269X0012 14A5688X012	1V3269X0042 14A5688X022	1V3269X0062 14A5688X082	10A3384X042 10A3437X062
4 6	10A3481X012 1V3350X0022	10A3483X012 1V3350X0012	10A3482X022 1V3350X0042	10A3479X052 10A3525X042

1. For hydrocarbon service to 71°C (160°F).
2. -18 to 38°C (0° to 100°F) for H₂O service.

Keys 20*, 20A*, & 20B* Seals (YD Only)

VALVE SIZE, NPS	YD (STANDARD)				YD (HIGH TEMPERATURE)
	Key 20A Seal Ring	Key 20B Back Up Ring			Key 20 Valve Plug Seal
	PTFE	Nitrile ⁽¹⁾ -29 to 93°C (-20 to 200°F)	Fluorocarbon ⁽²⁾ -18 to 204°C (0 to 400°F)	Ethylene Propylene -40 to 232°C (-40 to 450°F)	Graphite (2 req'd)
1/2, 3/4, 1, 1-1/2	10A3331X012	10A3332X022	10A3332X032	10A3332X042	10A3333X012
2, 2-1/2 3	10A3388X012 10A3442X012	10A3389X022 10A3443X022	10A3389X032 10A3443X032	10A3389X052 10A3443X072	10A3390X012 10A3444X012
4 6	10A3484X012 10A3530X012	10A3485X022 10A3531X022	10A3485X032 10A3531X032	10A3485X042 10A3531X052	10A3486X012 10A3532X012

1. For hydrocarbon service to 71°C (160°F).
2. -18 to 38°C (0° to 100°F) for H₂O service.

Keys 3, 4, 9, 11, 14, and 19 (NPS 8 YD Only)

PLUG/ CAGE / STEM KEY 3		CAGE RETAINER KEY 4	GASKET, QTY 3, KEY 9	SPIRAL WOUND GASKET, KEY 11		O-RING KEY 14	O-RING KEY 19
Low Temperature	High Temperature			Low Temperature, Qty 1	High Temperature, Qty 2	Low Temperature	Low Temperature
27B4290X012	27B4290X022	34B9111x012	1C2515X0052	10B5412X032	10B5412X032	1H8623X0022	1D2692X0022

Keys 20, 20A, 20B, 24, and 25 (NPS 8 YD Only)

BACK-UP RING, KEY 20A	SEAL RING, KEY 20B	SEAL RING, QTY 3, KEY 20	FLANGE ADAPTOR, KEY 24		BACK-UP RING, QTY 2, KEY 25	GASKET, QTY 2, KEY 25
Low Temperature	Low Temperature	High Temperature	Low Temperature	High Temperature	Low Temperature	High Temperature
10A3531X032	10A3530X012	10A3532X012	CL300: 34B6974X012 CL600: 37B9811X012	CL300: 34B6974X012 CL600: ---	12A54898X012	10A3525X042

Keys 6*, 7*, 8, and 10 Packing Box Parts

DESCRIPTION	KEY NUMBER	STEM DIAMETER, mm (INCHES)					
		9.5 (3/8)	12.7 (1/2)	19.1 (3/4)	25.4 (1)		
PTFE V-Ring Packing	Single packing set, PTFE (1 req'd for single, 2 req'd for double)	6	1R290001012	1R290201012	1R290401012	1R290601012	
	Spring, stainless steel (for single only)	8	1F125437012	1F125537012	1F125637012	1D582937012	
	Lantern Ring, stainless steel (for double only)	8	1F364135072	1J962335072	0N028435072	0U099735072	
	Quantity required	Double	---	1	2	1	1
	Special washer, stainless steel (for single only)	10	1F125236042	1F125136042	1F125036042	1H982236042	
PTFE/ Composition Packing	Packing Ring, PTFE/Composition	7	1F3370X0012	1E319001042	1E319101042	1D7518X0012	
	Quantity required	Double	---	7	10	8	8
	Lantern Ring, stainless steel (1 required for double)	8	1F364135072	1J962335072	0N028435072	0U099735072	
Graphite Ribbon/ Packing	Packing Ring, graphite filament	7	1F3370X0322	1E3190X0222	1E3191X0282	1D7518X0132	
	Quantity required	Single Double	---	2 4	2 4	3 5	3 5
	Packing ring, graphite ribbon	7	1V3160X0022	1V3802X0022	1V2396X0022	1U6768X0022	
	Quantity required	Single Double	---	2 3	2 3	2 3	2 3
	Lantern ring, S31600 (316 SST)	8	1F364135702	1J962335072	0N028435072	0U099735072	
	Quantity required	Single Double	---	2 1	3 2	2 1	2 1

ENVIRO-SEAL Bellows Seal Parts

Key	Description	Part Number	Key	Description	Part Number
1	Bonnet/ENVIRO-SEAL bellows seal bonnet If you need a bonnet or an ENVIRO-SEAL bellows seal bonnet as a replacement part, order by valve size and stem diameter, serial number, and desired material.	12A9016X012		stem (2 req'd for double packing) PTFE for NPS 3 and 4 with 12.7 mm (1/2 inch) stem (2 req'd for double packing)	12A9016X012
3	ENVIRO-SEAL bellows seal packing flange		7*	ENVIRO-SEAL bellows seal packing ring for low chloride graphite ribbon/filament packing arrangement	12A8832X012
4	ENVIRO-SEAL bellows seal stud bolt			Ribbon packing ring for 9.5 mm (3/8 inch) and NPS 2 with 12.7 mm (1/2 inch) stem (4 req'd)	18A0908X012
5	ENVIRO-SEAL bellows seal hex nut			Filament packing ring for 9.5 mm (3/8 inch) and NPS 2 with 12.7 mm (1/2 inch) stem (4 req'd)	1P3905X0172
6*	ENVIRO-SEAL bellows seal packing set PTFE for 9.5 mm (3/8 inch) stem (1 req'd for single packing, 2 req'd for double packing) PTFE for NPS 2 with 12.7 mm (1/2 inch)	12A9016X012		Ribbon packing ring for NPS 3 and 4 with 12.7 mm (1/2 inch) stem (4 req'd)	18A0918X012

Key	Description	Part Number	Key	Description	Part Number
	Filament packing ring for NPS 3 and 4 with 12.7 mm (1/2 inch) stem (4 req'd)	14A0915X042		NPS 1 w/ 9.5 mm (3/8 inch) stem	32B4224X012
8	ENVIRO-SEAL bellows seal spring			NPS 1-1/2 w/ 9.5 mm (3/8 inch) stem	32B4225X012
8	ENVIRO-SEAL bellows seal spacer			NPS 2 w/ 12.7 mm (1/2 inch) stem	32B4226X012
12*	ENVIRO-SEAL bellows seal upper wiper			NPS 3 w/ 12.7 mm (1/2 inch) stem	32B4227X012
	For 9.5 mm (3/8 inch) and NPS 2 with 12.7 mm (1/2 inch) stem	18A0868X012		NPS 4 w/ 12.7 mm (1/2 inch) stem	32B4228X012
	For NPS 3 and 4 with 12.7 mm (1/2 inch) stem	18A0870X012		N06022 trim mat'l, N06022 bellows mat'l	
13*	ENVIRO-SEAL bellows seal bushing			NPS 1 w/ 9.5 mm (3/8 inch) stem	32B4224X022
	For 9.5 mm (3/8 inch) stem (1 req'd), for NPS 2 with 12.7 mm (1/2 inch) stem (2 req'd)			NPS 1-1/2 w/ 9.5 mm (3/8 inch) stem	32B4225X022
	S31600/PTFE	18A0820X012		NPS 2 w/ 12.7 mm (1/2 inch) stem	32B4226X022
	R30006	18A0819X012		NPS 3 w/ 12.7 mm (1/2 inch) stem	32B4227X022
	S31600/Cr Coated	11B1155X012		NPS 4 w/ 12.7 mm (1/2 inch) stem	32B4228X022
	For NPS 3 and 4 with 12.7 mm (1/2 inch) stem (1 req'd)			2 Ply Bellows	
	S31600/PTFE	18A0824X012		S31600 trim mat'l, N06625 bellows mat'l	
	R30006	18A0823X012		NPS 1 w/ 9.5 mm (3/8 inch) stem	32B4224X032
	S31600/Cr Coated	11B1157X012		NPS 1-1/2 w/ 9.5 mm (3/8 inch) stem	32B4225X032
13*	ENVIRO-SEAL bellows seal bushing/liner			NPS 2 w/ 12.7 mm (1/2 inch) stem	32B4226X032
	For 9.5 mm (3/8 inch) stem (1 req'd), for NPS 2 with 12.7 mm (1/2 inch) stem (2 req'd)			NPS 3 w/ 12.7 mm (1/2 inch) stem	32B4227X032
	N10276 bushing, PTFE/glass liner	12B2713X012		NPS 4 w/ 12.7 mm (1/2 inch) stem	32B4228X032
	N10276 bushing, PTFE/carbon liner	12B2713X042		N06022 trim mat'l, N06022 bellows mat'l	
	For NPS 3 and 4 with 12.7 mm (1/2 inch) stem (1 req'd)			NPS 1 w/ 9.5 mm (3/8 inch) stem	32B4224X042
	N10276 bushing, PTFE/glass liner	12B2715X012		NPS 1-1/2 w/ 9.5 mm (3/8 inch) stem	32B4225X042
	N10276 bushing, PTFE/carbon liner	12B2715X042		NPS 2 w/ 12.7 mm (1/2 inch) stem	32B4226X042
15	ENVIRO-SEAL bellows seal Locknut			NPS 3 w/ 12.7 mm (1/2 inch) stem	32B4227X042
16	ENVIRO-SEAL bellows seal pipe plug (2 req'd)			NPS 4 w/ 12.7 mm (1/2 inch) stem	32B4228X042
20*	ENVIRO-SEAL bellows seal stem/bellows assembly		22*	ENVIRO-SEAL bellows seal bonnet gasket (graphite laminate)	
	1 Ply Bellows			NPS 1/2 through 1	12B6316X022
	S31600 trim mat'l, N06625 bellows mat'l			NPS 1-1/2	12B6317X022
				NPS 2	12B6318X022
				NPS 3	12B6319X022
				NPS 4	12B6320X022
			24	ENVIRO-SEAL bellows seal adaptor	
			28	ENVIRO-SEAL bellows seal nameplate, warning	
			29	ENVIRO-SEAL bellows seal drive screw (2 req'd)	
			36*	ENVIRO-SEAL bellows seal pin	12B3951X012
			37	ENVIRO-SEAL bellows seal warning tag	
			38	ENVIRO-SEAL bellows seal tie	
			39	ENVIRO-SEAL bellows seal thrust ring	

Neither Emerson, Emerson Automation Solutions, nor any of their affiliated entities assumes responsibility for the selection, use or maintenance of any product. Responsibility for proper selection, use, and maintenance of any product remains solely with the purchaser and end user.

Fisher and ENVIRO-SEAL are marks owned by one of the companies in the Emerson Automation Solutions business unit of Emerson Electric Co. Emerson Automation Solutions, Emerson, and the Emerson logo are trademarks and service marks of Emerson Electric Co. All other marks are the property of their respective owners.

The contents of this publication are presented for informational purposes only, and while every effort has been made to ensure their accuracy, they are not to be construed as warranties or guarantees, express or implied, regarding the products or services described herein or their use or applicability. All sales are governed by our terms and conditions, which are available upon request. We reserve the right to modify or improve the designs or specifications of such products at any time without notice.

Emerson Automation Solutions
Marshalltown, Iowa 50158 USA
Sorocaba, 18087 Brazil
Cernay 68700 France
Dubai, United Arab Emirates
Singapore 128461 Singapore

www.Fisher.com

