

Inspection of Pressure Relieving Devices

API RECOMMENDED PRACTICE 576
FOURTH EDITION, (MONTH), 20XX

Inspection of Pressure Relieving Devices

1 Scope

This recommended practice (RP) describes the inspection and repair practices for self-actuated pressure relieving devices commonly used in the oil/gas and petrochemical industries. As a guide to the inspection and repair of these devices in the user's plant, it is intended to ensure their proper performance. This publication covers self-actuated devices such as direct acting spring loaded valves, pilot operated pressure-relief valves, rupture disks, pin actuated devices and weight-loaded pressure vacuum vents.

The recommendations in this publication are not intended to supersede requirements established by regulatory bodies. This publication excludes tank weak seams and/or sections or tank thief hatches, explosion doors, fusible plugs, control valves, pressure regulating devices, integral rotating equipment components, other devices that either depend on an external source of power for operation or are manually operated or devices not designed to be inspected or recertified. Inspections and tests made at manufacturers' plants, which are usually covered by codes or purchase specifications, are not covered by this publication.

This publication does not cover training requirements for personnel involved in the inspection and repair of pressure relieving devices. Those seeking these requirements should see API 510/570, which gives the requirements for a quality control system and specifies that the repair organization maintain and document a training program ensuring that personnel are qualified.

2 Normative References

The following referenced documents are indispensable for the application of this document. For dated references, only the edition cited applies. For undated references, the latest edition of the referenced document (including any amendments) applies.

API 510, *Pressure Vessel Inspection Code: In-service Inspection, Rating, Repair, and Alteration*

API Standard 520 (All Parts), *Sizing, Selection, and Installation of Pressure relieving Devices in Refineries*

API Standard 521, *Pressure relieving and Depressuring Systems*

API Standard 526, *Flanged Steel Pressure-relief Valves*

API Standard 527, *Seat Tightness of Pressure Relief Valves*

API Standard 570, *Piping Inspection Code: In-service Inspection, Rating, Repair, and Alteration of Piping Systems*,

API Recommended Practice 580, *Risk-Based Inspection*

API Standard 653, *Tank Inspection, Repair, Alteration, and Reconstruction* API Standard 620, *Design and Construction of Large, Welded, Low-pressure Storage Tanks*

API Standard 650, *Welded Tanks for Oil Storage*

API Standard 2000, *Venting Atmospheric and Low-pressure Storage Tanks (Nonrefrigerated and Refrigerated)*

ASME PTC 25 ¹, *Pressure Relief Devices*

ASME Section VIII, Div. 1, *Boiler and Pressure Vessel Code*

NB-18 ², *Pressure Relief Device Certification*

3 Terms and Definitions

When used within this document, the following terms and definitions apply.

3.1

accumulation

The pressure increase over the maximum allowable working pressure of the vessel ~~pressure-relief device~~, expressed in pressure units or as a percentage of maximum allowable working pressure or design pressure if a MAWP has not been established. Maximum allowable accumulations are established by applicable codes for emergency, operating and fire contingencies.

3.2

backpressure

The pressure that exists at the outlet of a pressure-relief device as a result of the pressure in the discharge system. Backpressure is the sum of the superimposed and built-up backpressures.

3.3

blowdown

The difference between the set pressure and the closing pressure of a pressure-relief valve, expressed as a percentage of the set pressure or in pressure units.

3.4

built-up backpressure

The increase in pressure at the outlet of a pressure-relief device that develops as a result of flow after the pressure-relief device opens.

3.5

burst pressure

The value of the upstream static pressure minus the value of the downstream static pressure just prior to when the disk bursts. When the downstream pressure is atmospheric, the burst pressure is the upstream static gauge pressure.

3.6

burst pressure tolerance

The variation around the marked burst pressure at the specified disk temperature in which a rupture disk will burst.

3.7

car seal

A device installed on a valve to secure it in a specified position (open or closed). When properly installed, the associated valve cannot be operated unless the car seal is physically removed.

¹ ASME International, Three Park Avenue, New York, New York, 10016-5990, www.asme.org.

² The National Board of Boiler and Pressure Vessel Inspectors, 1055 Crupper Avenue, Columbus, Ohio 43229, www.nationalboard.org.

3.8**closing pressure**

The value of decreasing inlet static pressure at which the valve disc reestablishes contact with the seat or at which lift becomes zero, as determined by seeing, feeling or hearing.

3.9**cold differential test pressure (CDTP)**

The pressure at which a pressure-relief valve is adjusted to open on the test stand. The cold differential test pressure includes corrections for the service conditions of superimposed backpressure or temperature or both.

3.10**design pressure**

The pressure, together with the design temperature, used to determine the minimum permissible thickness or physical characteristic of each vessel component as determined by the vessel design rules. The design pressure is selected by the user to provide a suitable margin above the most severe pressure expected during normal operation at a coincident temperature. It is the pressure specified on the purchase order. This pressure may be used in place of the maximum allowable working pressure (MAWP) in all cases where the MAWP has not been established. The design pressure is equal to or less than the MAWP.

3.11**galling**

A condition whereby excessive friction between high spots results in localized welding with subsequent splitting and a further roughening of rubbing surfaces of one or both of two mating parts.

3.12**huddling chamber**

An annular chamber located downstream of the seat of a pressure-relief valve for the purpose of assisting the valve to achieve lift.

3.13**lift**

The actual travel of the disc away from the closed position when a pressure-relief valve is relieving.

3.14**lifting lever**

A device on the relief valve that applies external force to the stem of the relief valve which can be used to manually operate the valve.

3.15**manufacturing design range**

The pressure range at which the rupture disk shall be marked. Manufacturing design ranges are usually catalogued by the manufacturer as a percentage of the specified burst pressure. Catalogued manufacturing ranges may be modified by agreement between the user and the manufacturer.

3.16**marked burst pressure**

The burst pressure established by tests for the specified temperature and marked on the disk tag by the manufacturer. The marked burst pressure may be any pressure within the manufacturing design range unless otherwise specified by the customer. The marked burst pressure is applied to all of the rupture disks of the same lot.

3.17**maximum allowable working pressure (MAWP)**

The maximum gauge pressure permissible at the top of a vessel in its operating position at the designated coincident temperature specified for that pressure. The pressure is the least of the values for the internal or external pressure as determined by the vessel design rules for each element of the vessel using actual nominal thickness, exclusive of additional metal thickness allowed for corrosion and loadings other than pressure. The MAWP is the basis for the pressure setting of the pressure-relief devices that protect the vessel. The MAWP is normally greater than the design pressure but can be equal to the design pressure when the design rules are used only to calculate the minimum thickness for each element and calculations are not made to determine the value of the MAWP.

3.18**non-reclosing pressure-relief device**

A pressure-relief device, which remains open after operation. A manual resetting means may be provided.

3.19**opening pressure**

The value of increasing inlet static pressure whereby there is a measurable lift of the disc or at which discharge of the fluid becomes continuous, as determined by seeing, feeling or hearing.

3.20**overpressure**

The pressure increase over the set pressure of the relieving device. Overpressure is expressed in pressure units or as a percentage of set pressure. Overpressure is the same as accumulation only when the relieving device is set to open at the maximum allowable working pressure of the vessel.

3.21**pop pressure**

The value of increasing inlet static pressure at which the disc moves in the opening direction at a faster rate as compared with corresponding movement at higher or lower pressures

3.22**pin-actuated device**

A non-reclosing pressure-relief device actuated by static pressure and designed to function by buckling or breaking a pin which holds a piston or a plug in place. Upon buckling or breaking of the pin, the piston or plug instantly moves to the full open position.

3.23**qualified person**

A competent person who has met the knowledge, skill requirements and expectations of the owner-user.

3.24**set pressure**

The inlet gauge pressure at which a pressure-relief valve is set to open under service conditions.

3.25**simmer**

The audible or visible escape of compressible fluid between the seat and disc, which may occur at an inlet static pressure below the set pressure prior to opening.

3.26

specified burst pressure

The burst pressure specified by the user. The marked burst pressure may be greater than or less than the specified burst pressure but shall be within the manufacturing design range. The user is cautioned to consider manufacturing design range, superimposed backpressure and specified temperature when determining a specified burst pressure.

3.27

superimposed backpressure

The static pressure that exists at the outlet of a pressure-relief device at the time the device is required to operate. It is the result of pressure in the discharge system coming from other sources and may be constant or variable.

3.28

tell-tale indicator

An assembly installed in the space between a rupture disk and another relief device (in series) to detect or prevent the accumulation of pressure between the rupture disk and the other device.

3.29

trim

Refers to internal parts of a pressure-relief valve that are manufactured using materials that are resistant to degradation from the associated process. At a minimum, it refers to the nozzle and disc, but may also include other components that are in contact with the process fluids (disc holder, blowdown ring, guide, spindle, etc.) or are required for proper valve performance.

4 Pressure Relieving Devices (PRD)

4.1 General

Pressure relieving devices protect equipment and personnel by opening at predetermined pressures and preventing the adverse consequences of excessive pressures in process systems and storage vessels.

A pressure-relief device is actuated by inlet static pressure and designed to open during emergency or abnormal conditions to prevent a rise of internal fluid pressure in excess of a specified design value. The device may also be designed to prevent excessive internal vacuum. The device may be a pressure-relief valve, a non-reclosing pressure-relief device, or a vacuum relief valve.

Common examples include direct spring loaded pressure-relief valves, pilot operated pressure-relief valves, rupture disks, buckling pin devices and weight-loaded devices.

Refer to API STD 520, Part I or API STD 2000 for more information regarding pressure-relief device design considerations.

4.2 Pressure-relief valve (PRV)

A pressure-relief valve is designed to open for the relief of excess pressure and reclose thereby preventing further flow of fluid after normal conditions have been restored. A pressure-relief valve opens when its upstream pressure reaches the opening pressure. It then allows fluid to flow until its upstream pressure falls to the closing pressure. It then closes, preventing further flow. The term pressure-relief valve is generic in nature and these devices can be classified as a safety valve, relief valve, or a safety relief valve.

4.2.1 Safety Valve

A safety valve is a pressure-relief valve that is actuated by the static pressure upstream of the valve and characterized by rapid opening or pop action. A safety valve is normally used with

compressible fluids. Safety valves are used on steam boiler drums and super-heaters and are also used for general air, gas and steam services in refinery and petrochemical plants.

When the static inlet pressure reaches the set pressure, it will increase the pressure upstream of the disc and overcome the seating force on the disc. Fluid will then enter the huddling chamber, providing additional opening force. This will cause the disc to lift and provide full opening at specified overpressure. The closing pressure will be less than the set pressure and will be reached after the blowdown phase is completed.

4.2.2 Relief Valve

A relief valve is a pressure-relief valve actuated by the difference between static pressure upstream of the valve and superimposed back pressure downstream (unless pressure compensated i.e. with bellows or balancing) and opens normally in proportion to the pressure increase over the opening pressure. A relief valve is normally used with incompressible fluids. A relief valve begins to open when the static inlet pressure reaches its set pressure. When the static inlet pressure overcomes the seating force, the disc begins to lift off the seat, allowing flow of the liquid. The value of the closing pressure is lower than the set pressure and will be reached after the blowdown phase is complete.

4.2.3 Safety Relief Valve

A safety relief valve is a pressure-relief valve that may be used as either a safety or relief valve depending on the application. The trim of the safety relief valve will provide stable lifting characteristics on either compressible or incompressible media.

4.3 Direct Acting Pressure-relief valve

A direct acting pressure-relief valve uses a weight or compressed spring to hold the valve seat closed below the set pressure or vacuum setting of the device.

4.3.1 Weight Loaded Pressure / Vacuum Relief Valve

These devices are used in pressure and / or vacuum protection applications where operating pressures are very near atmospheric conditions. The set pressure or vacuum setting can be changed by adding or removing weights in the seating area of the valve. These devices are normally vented to atmosphere (See Figure 1). They are often used to satisfy the normal venting requirements caused by thermal inbreathing/outbreathing and product pump in / pump out effects.

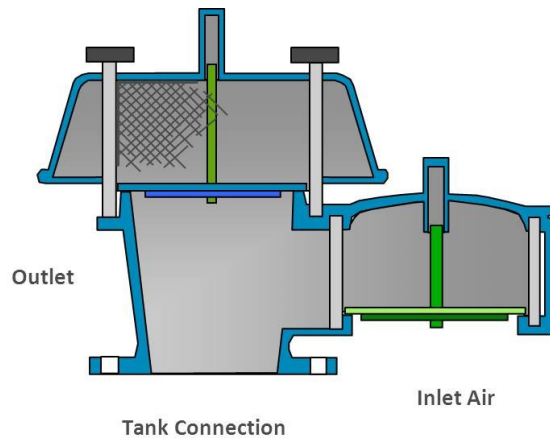

Figure 1 - Pressure/Vacuum Relief Valve

There are times where additional venting requirements are needed for emergency overpressure scenarios such as external tank fire. Weight loaded emergency vents can provide this additional capacity. These are typically hinged devices that have a hatch of sufficient weight to open at the needed set pressure. They are typically set higher than the normal venting devices as the hatch of the emergency vent will not reclose after opening. (See Figure 2)



Figure 2 - Weight loaded emergency vent

4.3.2 Direct Spring Operated Pressure-relief valve

These devices use the compression of a spring to determine the set pressure. The spring may be externally visible in what is called an open bonnet valve. See Figure 3. Caution should be taken to install open bonnet valves away from personnel as the exhaust of the media during a relieving cycle will release to the ambient via this open bonnet.

Caution: Open bonnet PRVs shall not be used in hydrocarbon or toxic services. They should only be used in non-hazardous service (i.e.: air, water and some steam applications).

There are conventional and balanced types of direct spring operating pressure-relief valves.

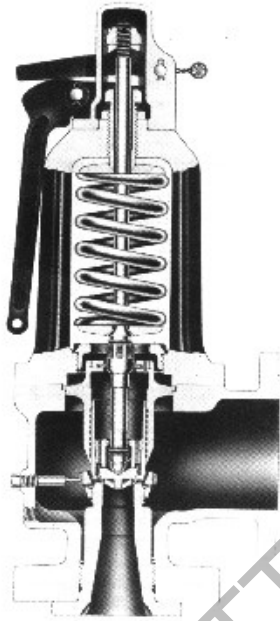

Figure 3 - Open Bonnet, Direct Acting Spring Loaded Pressure-relief valve

4.3.2.1 Conventional Direct Spring Operated Pressure-relief valve.

A conventional valve can utilize a closed spring bonnet that will allow any backpressure to be contained within all areas of the valve downstream of the seat. This backpressure can affect the set pressure, stability and available capacity that can be provided. Figure 4 shows a typical API 526 conventional direct spring operated pressure-relief valve.

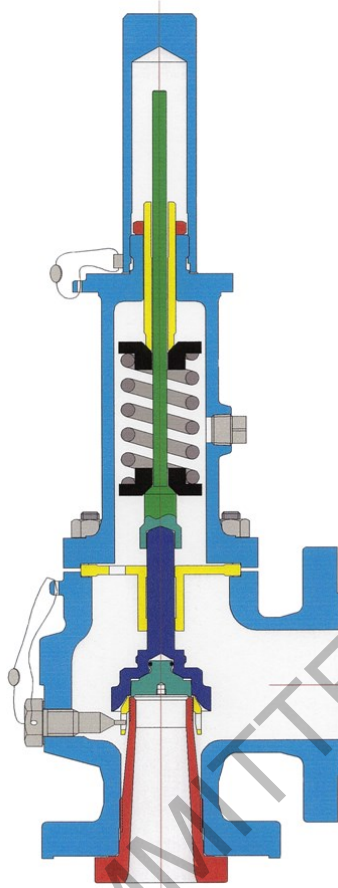

Figure 4 - Closed Bonnet, Direct Acting Spring Loaded Relief Valve

4.3.2.2 Balanced Direct Spring Operated Pressure-relief valve

A balanced valve incorporates a bellows or other means for minimizing the effect of backpressure on the operational characteristics of the valve. A balanced valve will have a vented spring bonnet. See Figure 5. The vented bonnet allows the valve to operate without bias from the back pressure if the bellows or other balancing member should fail. This vent should always be referenced to atmospheric pressure. If the valve is located where atmospheric venting would present a hazard, or is not permitted by environmental regulations, the vent may be piped to a safe location that is free of back pressure. Refer to API 520 Part II – Section 10 for bonnet or Pilot vent piping.

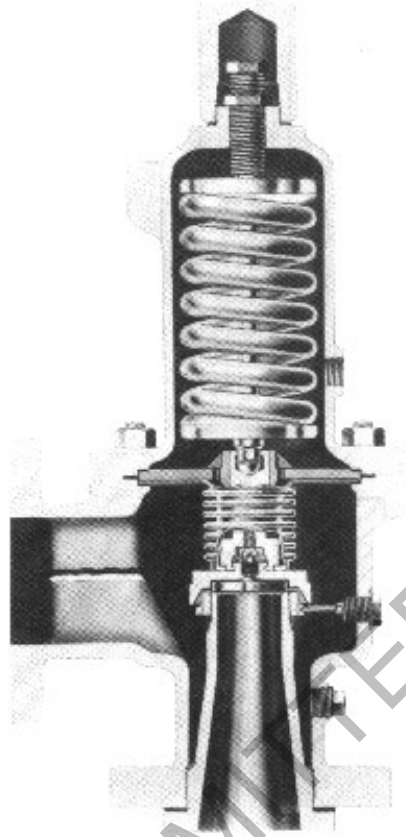

Figure 5 - Balanced Bellows Direct Acting Spring Loaded Pressure-relief valve

4.4 Pilot-Operated Pressure-relief valves

A pilot operated pressure-relief valve consists of a major relieving device or main valve, which is combined with and controlled by a self-actuated auxiliary pressure-relief valve (pilot). Just as with direct acting valves the pilot operated valve can be a safety valve (also called a snap action design), relief or safety relief valve (also called a modulating acting design) type.

Pilot operated pressure-relief valve are generally used:

- where a large relief area and/or high set pressures are required;
- where a low differential exists (operating margin) between the normal pressure equipment (vessel and piping) operating pressure and the set pressure of the valve;
- on large low-pressure storage tanks;
- where very short blowdown is required;
- where backpressure is very high and balanced design is required;

- where process conditions require sensing of pressure at one location and relief of fluid at another location;
- where inlet or outlet piping frictional pressure losses are high; and
- where in-situ, in service, set pressure verification is desired.

The pilot is a spring loaded valve that operates when its inlet static pressure exceeds its set pressure. This causes the main valve to open and close according to the pressure. Process pressure is either vented off by the pilot valve to open the main valve or applied to the top of the unbalanced piston (Figure 7), or diaphragm (Figure 6), of the main valve to close it. The diaphragm main valve design can also be used as a vacuum venting device, where either the weight of the main valve trim or a pilot valve set on vacuum controls the opening and closing of the main valve.

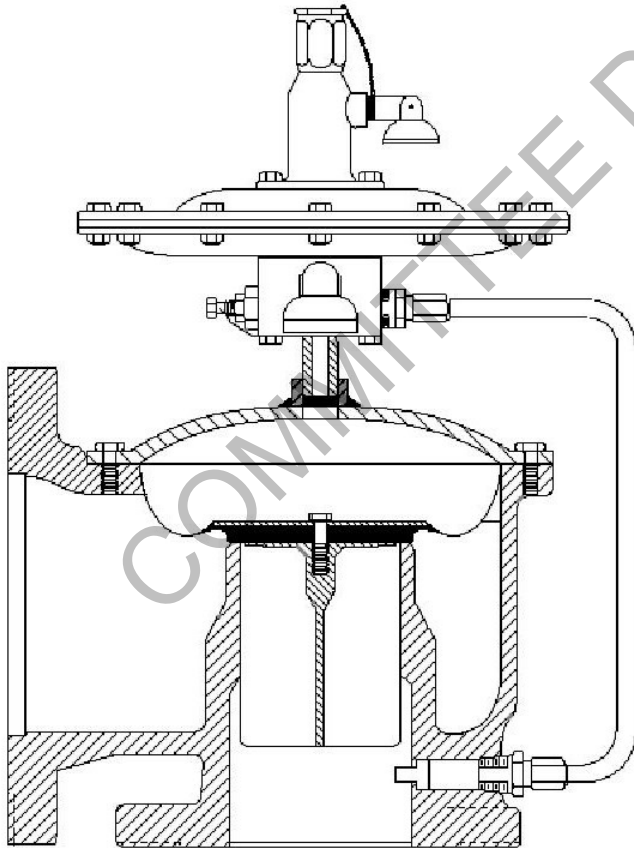

Figure 6 - Diaphragm main valve, Pilot-Operated Pressure-relief valve

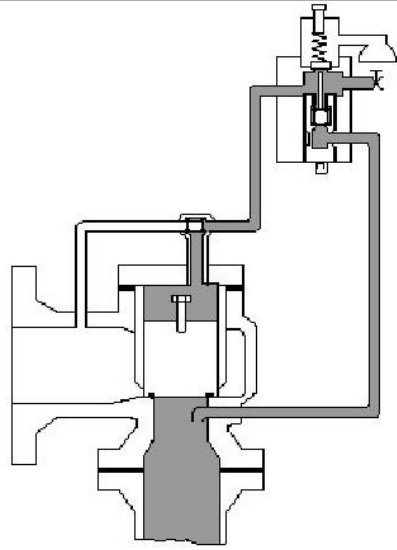

Figure 7 - Unbalanced piston main valve, Pilot-Operated Pressure-relief valve

COMMITTEE DRAFT



Figure 8 - Diaphragm main valve, pilot operated pressure and vacuum relief valve

4.5 Rupture Disk (RD) Device

4.5.1 General

A rupture disk device is a non-reclosing pressure-relief device actuated by the static differential pressure between the inlet and outlet of the device and designed to function by the bursting of a rupture disk. A rupture disk device includes a rupture disk and, where applicable, a rupture disk holder.

- a) A rupture disk is a pressure containing, pressure and temperature sensitive element of a rupture disk device.
- b) A rupture disk holder is the structure which encloses and clamps the rupture disk in position. Rupture disks typically require a rupture disk holder although some disk designs can be installed between standard flanges without holders.
- c) A non-fragmenting rupture disk is a rupture disk designed and manufactured to be installed upstream of other piping components, such as PRVs, other types of valves, rotating equipment and other applications where rupture disk fragments can affect operation and/or cause restricted flow.

There are three major rupture disk types: Forward Acting, Reverse Acting and Graphite.

4.5.1.1 Forward Acting Rupture Disks

Forward acting, tension loaded, rupture disks are pressurized on the concave side such that the stresses in the dome are primarily tensile. Forward acting rupture disks are designed to open by methods including tensile fracture of the dome, slitting, or scoring.

4.5.1.1.1 Forward Acting Conventional Rupture Disks

A forward acting conventional rupture disk is a formed (domed), solid metal disk designed to burst at a rated pressure applied to the concave side. See Figure 9. This rupture disk typically has an angular seat design. The disk can be furnished with a support to prevent reverse flexing under vacuum or backpressure conditions. These disks have a random opening pattern and are considered fragmenting designs that are not suitable for installation upstream of a PRV.



Figure 9 - Forward Acting Conventional Rupture Disk

4.5.1.1.2 Forward Acting Scored Rupture Disks

The forward acting scored rupture disk is a formed (domed) disk designed to burst along score lines at a rated pressure applied to the concave side. See Figure 10. Most designs withstand vacuum conditions without a vacuum support. If backpressure conditions are present, the disk can be furnished with a support to prevent reverse flexing. Because the score lines control the opening pattern, this type of disk is generally non-fragmenting and is acceptable for installation upstream of a PRV.

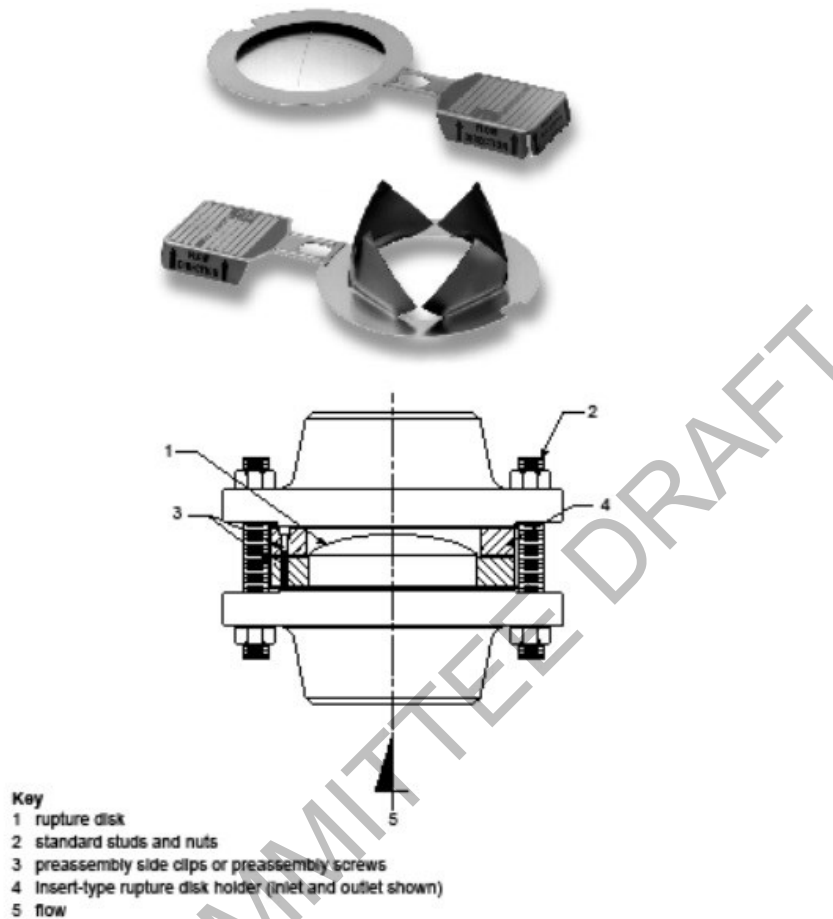

Figure 10 - Forward Acting Scored Rupture Disk

4.5.1.1.3 Forward Acting Composite Rupture Disks

A forward acting composite rupture disk is a flat or domed multi-piece construction disk. The domed composite rupture disk is designed to burst at a rated pressure applied to the concave side. Some designs are non-fragmenting and acceptable for use upstream of a PRV.

The domed composite rupture disk is available in flat seat or angular seat design. The burst pressure is controlled by the combination of slits and tabs in the top section and a metallic or nonmetallic seal member under the top section. If vacuum or backpressure conditions are present, composite disks can be furnished with a support to prevent reverse flexing.

The flat composite rupture disk may be designed to burst at a rated pressure in either or both directions. A flat composite rupture disk usually comes complete with gaskets and is designed to be installed directly between companion flanges rather than within a specific rupture disk holder.

4.5.1.2 Reverse Acting Rupture Disks

Reverse acting, compression loaded rupture disks are pressurized on the convex side such that the stresses in the dome are primarily compressive. Reverse acting rupture disks are designed to open by such methods as shear, knife blades, tooth rings, or scored lines.

4.5.1.2.1 Reverse Acting Knife Blade Rupture Disks

Knife blades installed in holders should be constructed of corrosion-resistant material and should be inspected periodically to ensure sufficient sharpness to open the disk. Dull or damaged knife blades will likely prevent proper opening of the disk. See Figure 11.

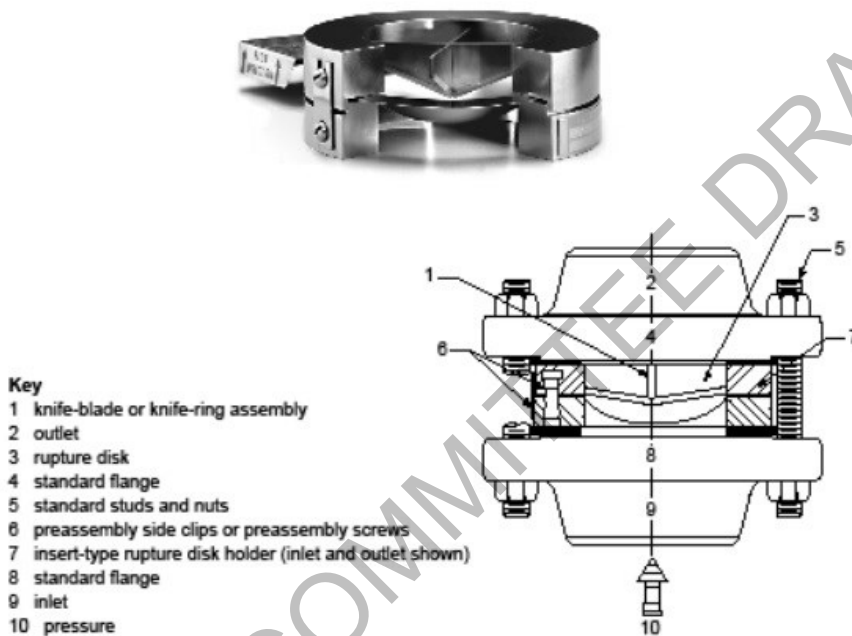

Figure 11 - Reverse Acting Knife Blade Rupture Disk

4.5.1.2.2 Reverse Acting Scored Rupture Disks

Reverse acting rupture disks are generally designed to be non-fragmenting and are frequently installed upstream of PRVs. These disks provide satisfactory service life when operating pressures are 90 % or less of marked burst pressure (90 % operating ratio). Some types of reverse-buckling disks are designed to be exposed to pressures up to 95 % of the marked burst pressure. Consult the manufacturer for the actual recommended operating ratio for the specific disk under consideration. Because a reverse acting rupture disk is operated with pressure applied on the convex side, thicker disk materials may be used, thereby lessening the effects of corrosion, eliminating the need for vacuum support, and providing longer service life under pressure/vacuum cycling conditions and pressure fluctuations. See Figure 12.

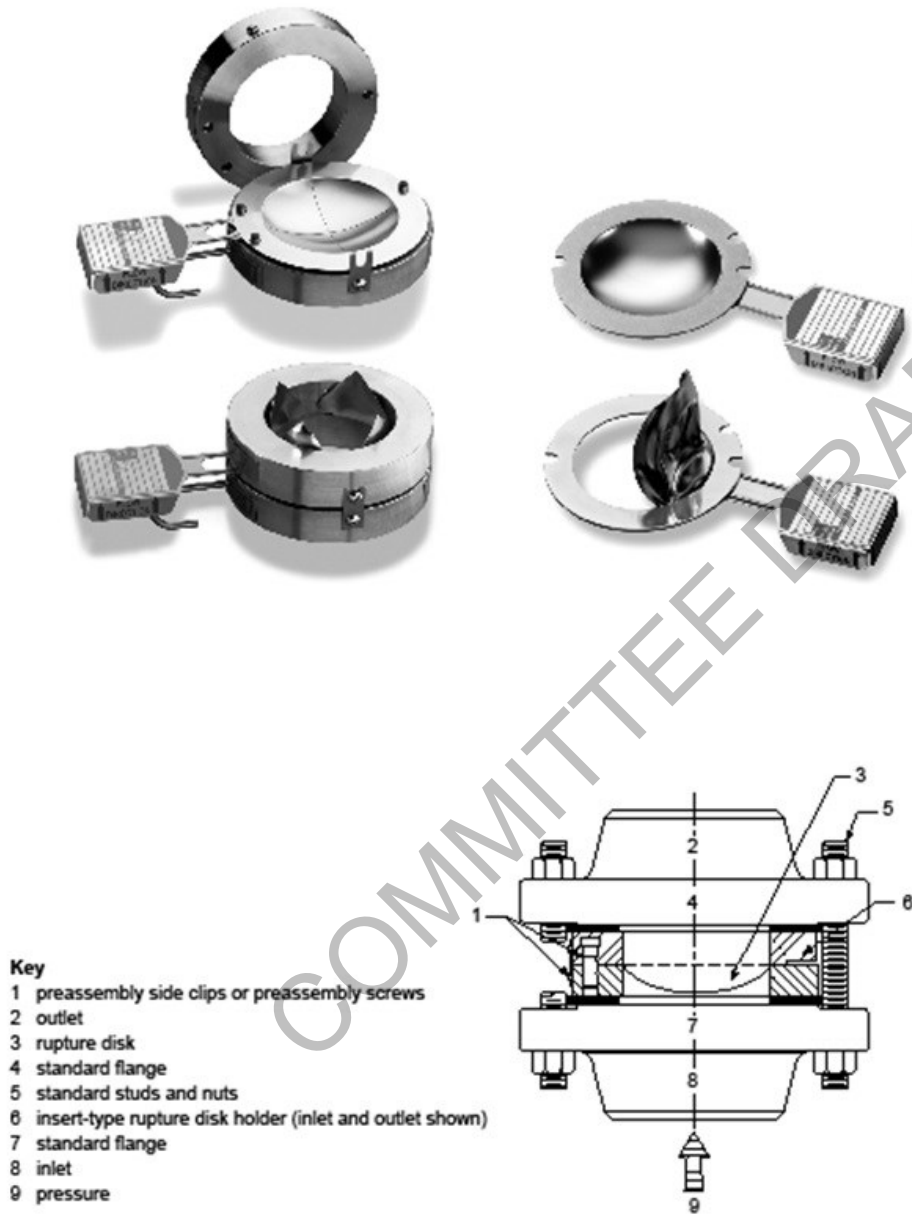

Figure 12 - Reverse Acting Scored Rupture Disk

4.5.1.3 Graphite Rupture Disks

Graphite, shear loaded, rupture disks are flat and are designed to open by bending and/or shearing of the membrane.

4.5.1.3.1 Graphite Rupture Disks

A graphite rupture disk is manufactured from graphite impregnated with a binder material and designed to burst by bending or shearing (see Figure 13). Most graphite disks do not utilize a holder and install directly between pipe flanges. A vacuum support may be required for low pressure disks that are subject to process vacuum. Graphite rupture disks fragment upon rupture.

If vacuum or backpressure conditions are present, the disk can be furnished with a support to prevent reverse flexing. These disks have a random opening pattern and are considered fragmenting designs that are not suitable for installation upstream of a PRV. A metallic ring called armoring is often added to the outside diameter of the disk to help support uneven piping loads and minimize the potential for cracking of the outer graphite ring and blowout of process fluid.

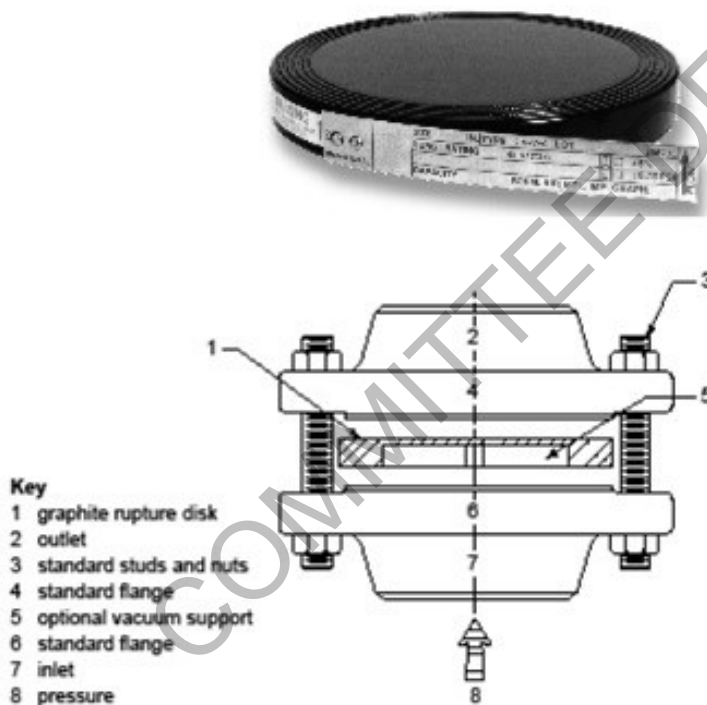

Figure 13 - Graphite Rupture Disk

4.5.2 Rupture Disk Holders

Rupture disk holders are used to clamp the rupture disk in place and affect a leak-tight, metal-to-metal seal. The seating area of the holders is typically unique to specific manufacturers and styles of rupture disks. Rupture disk holders are available in a variety of configurations including full bolting, weldneck, threaded, etc. The most common configuration is the insert type which fits between standard pipe flanges, and the outside diameter of the holder fits inside the flange studs.

Rupture disk holders are available in a variety of materials and coatings. See Figures 14, 15, 16, 17 and 18.

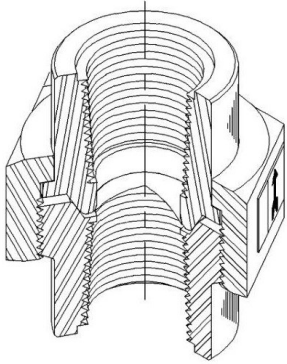

Figure 14 - Rupture Disk in union holder

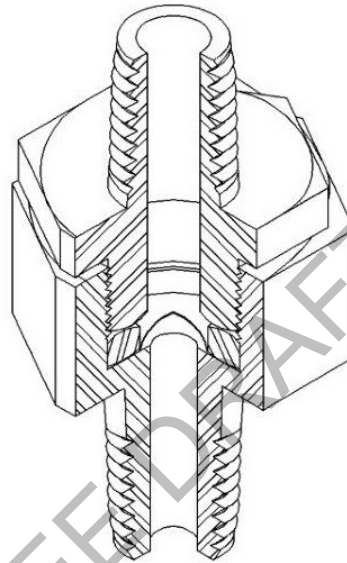

Figure 15 - Rupture Disk in Screw Type Holder

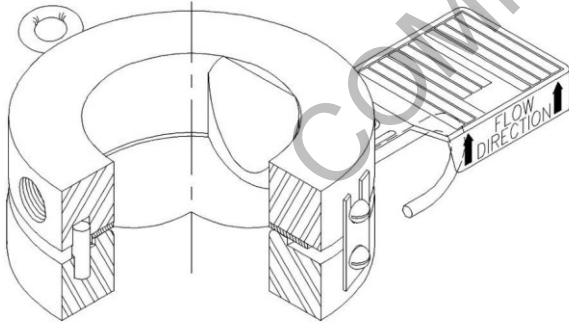

Figure 16 - Rupture Disk with Insert Type Holder

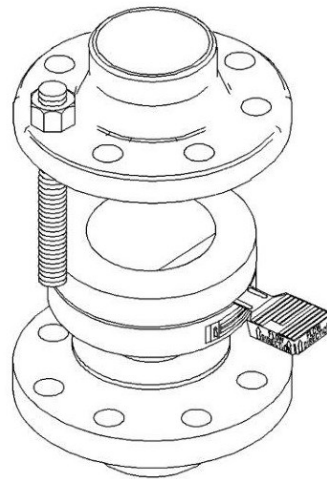

Figure 17 - Insert Type Holder Installation

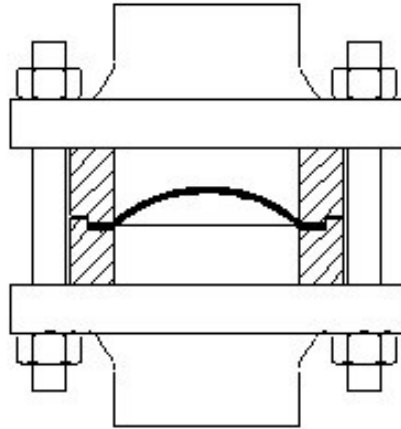

Figure 18 - Conventional Domed Rupture Disk

4.5.3 Applications of Rupture Disk Devices

4.5.3.1 Single Relieving Device

- a) when complete discharge of the process contents can be tolerated when the disk ruptures
- b) when a fast opening response is required

4.5.3.2 Supplemental Relieving Device

- a) to provide larger relief area for remote likelihood overpressure scenarios

4.5.3.3 Combination with Pressure-relief valve

The primary reasons for applying rupture disks upstream of pressure-relief valves include:

- a) Prevent plugging of PRV – some RD designs are designed to be less sensitive to product buildup.
- b) Prevent corrosion of PRV – The RD is used to prevent corrosive materials from contacting the PRV internals during normal operating conditions. Exposure is limited to the overpressure scenario duration plus the length of time it takes to replace the disk.
- c) Avoid cost of high alloy PRV – High alloys or exotic alloys for RD construction cost much less than a corresponding relief valve with the same alloy trim.
- d) Prevent leakage through PRV – minimize fugitive emissions through the pressure-relief valve.

A rupture disk may be installed on the downstream side of a pressure-relief valve to protect against corrosion from downstream headers or atmospheric exposure.

4.5.3.4 Requirements for Rupture Disks in Combination with Pressure-relief valves

When installing a rupture disk between pressure equipment (vessel and piping) and a pressure-relief valve, the requirements are as follows:

4.5.3.4.1 Monitoring (tell-tale indicator)

Since the RD is a differential pressure device, the pressure in the pressure equipment (vessel and piping) required to burst the disk will increase equally with any pressure that accumulates between the RD and PRV. The space between the RD and PRV shall be vented and/or monitored to prevent or detect pressure buildup between the RD and the PRV. ASME Section VIII, Div. 1, UG-127 requires the use of a pressure gage, a try cock, free vent (vent open to atmosphere), or suitable telltale indicator.

- a) If the space is not vented then a pressure gage alone should not be considered suitable, because the process could operate in an unsafe manner for an indefinite period of time.
- b) A pressure switch or transmitter that provides an alarm in the control room is a good solution
- c) A pressure gage along with a pressure switch or transmitter may be an even better choice so not only the control room is notified but the maintenance personnel also have visibility to the elevated pressure condition prior to breaking loose the pipe flanges.
- d) An excess flow valve installed at the end of the free vent would allow small leaks (e.g., pinholes) across the RD to be vented but closes when the leak rate is high to minimize emissions to atmosphere.
- e) The use of a break wire or other flow sensitive burst indication devices alone are not considered suitable unless they are capable of detecting leakage through the rupture disk.
- f) No one configuration is ideal for all applications. The corrosiveness or toxicity of the media is often what drives how this space is monitored and vented.

4.5.3.4.2 Fragmentation

The rupture disk used on the inlet side of a PRV shall not interfere with the performance of the PRV and shall be of a non-fragmenting design. In other words the disk shall not eject material that can impair PRV performance; this includes relief capacity as well as the ability to reclose without leakage. It should be noted that once the disk has burst, corrective measures shall be taken to reduce the vessel pressure. Some rupture disks may fragment eventually under sustained or repeated relieving conditions.

4.5.3.4.3 Size

For nozzle-type direct spring PRV's, the rupture disk shall be the same nominal pipe size as the PRV inlet or larger.

4.5.3.4.4 Installation

A common installation is one where the rupture disk holder is mounted directly upstream of the PRV. This installation is referred to as "close-coupled". This is a good installation approach but care needs to be taken to ensure that the holder provides sufficient clearance to allow the rupture disk to open without blocking the nozzle of the PRV. Single petal rupture disks may extend significantly beyond the end of the holder after rupture and have the potential to block the PRV nozzle.

In other cases the rupture disk holder and PRV may be separated by a spacer or length of pipe. Short sections of 1 or 2 pipe diameters in length are preferred. Longer lengths may result in the PRV not opening when the rupture disk opens. Longer pipe sections have been known to result in reflective pressure waves that can cause the rupture disk petals to re-close or even fragment when they ordinarily would not.

4.6 Pin Actuated Devices

4.6.1 General

Pin actuated devices are non-reclosing pressure-relief devices actuated by the static differential pressure between the inlet and outlet of the device and designed to function by the activation of a precision pin. The most common activation mode of the pin is buckling but some designs may

incorporate other modes such as bending or breaking. Pin devices can generally be categorized in two configuration types, piston type and butterfly type.

4.6.2 Piston Type

Piston type pin activated devices utilize a pin which holds a piston in place. Inlet pressure applied to the piston transmits force to the pin. When the force on the pin reaches the activation point, it will bend or break and allow the piston to lift and provide relief. See Figure 19.

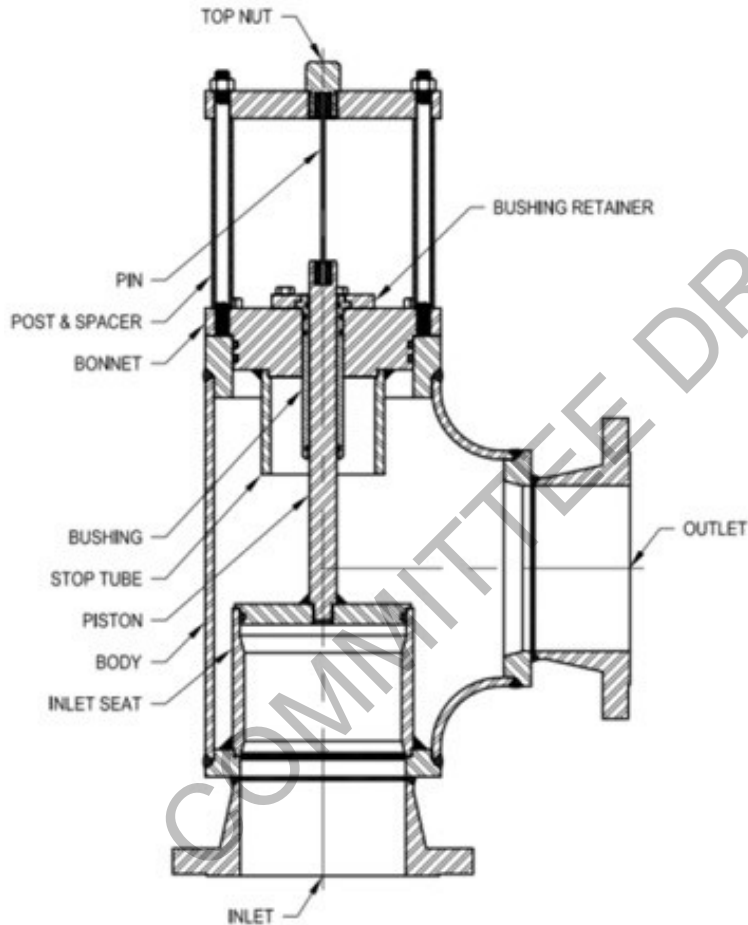

Figure 19 - Piston Type Pin Actuated Device

4.6.3 Butterfly Type

Butterfly type pin activated devices utilize an offset butterfly design. Inlet pressure applied to the butterfly generates a torque on the shaft. The torque transmits a force to the pin via linkage mechanism. When the force on the pin reaches the activation point it will bend or break and allow the butterfly to rotate and provide relief. See Figure 20.

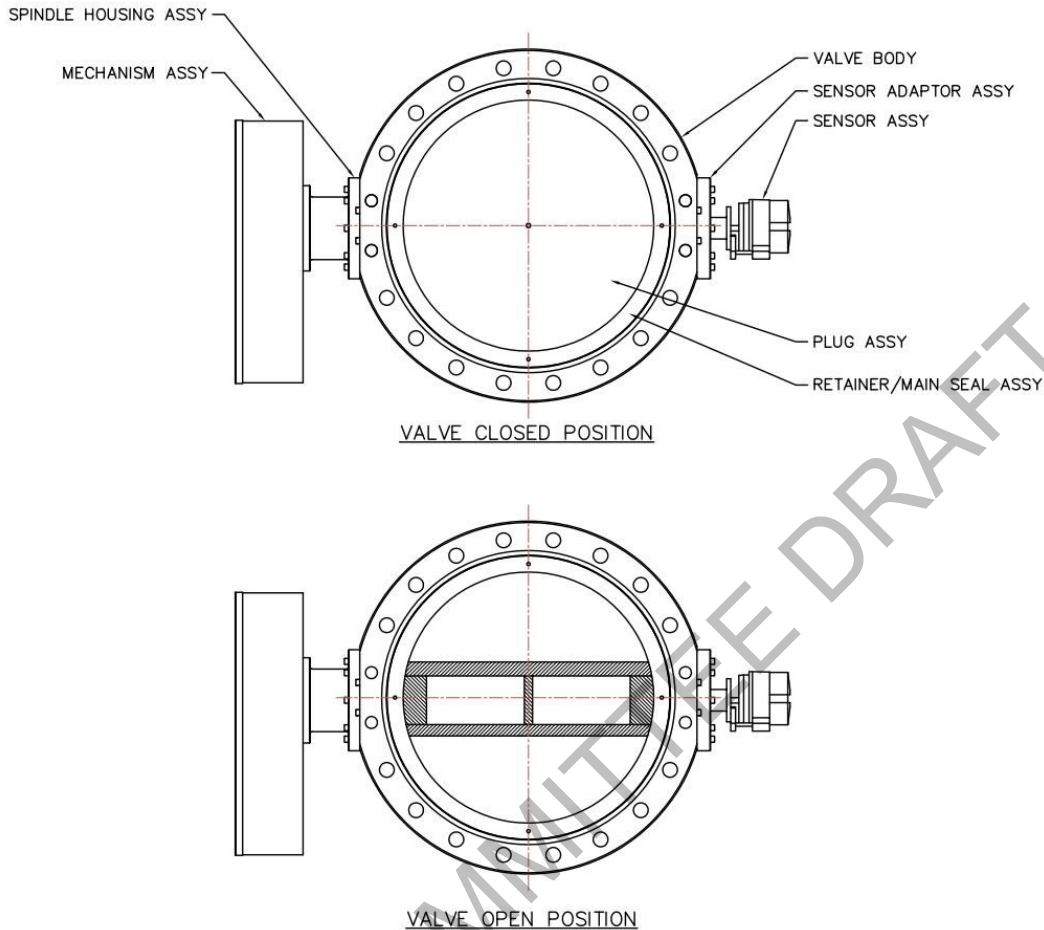

Figure 20 - Butterfly Type Pin Actuated Device

5 Causes of Improper Performance

5.1 Corrosion

Corrosion is a basic cause of many of the difficulties encountered with pressure-relief devices. An understanding of the process/operating conditions and resulting damage mechanisms are required in order to establish and maintain an inspection program of relief valves that yields the highest probability of preventing their damage. Changes in process/operating conditions need to include an evaluation of the corrosion potential of the relief valve. There are several other sources of industry data that specifically identify typical degradation mechanisms for various operating units. Specifically applicable to the refining and petrochemical industry is API RP 571 covering damage mechanisms.

Corrosion often appears as: pitted or broken valve parts, deposits of corrosive residue that interfere with the operation of the moving parts, or a general deterioration of the material of the

relieving device. Figure 21 through Figure 26 illustrate the effects of corrosion on relief devices. In addition to internal parts, exposed studs are vulnerable to environmental corrosion attack.

COMMITTEE DRAFT



Figure 21 - Acid Corrosion in Carbon Steel Bonnet Caused by Leaking Seating Surfaces

COMMITTEE DRAFT



Figure 22 - Chloride Corrosion on 18Cr-8Ni Steel Nozzle (with Machined Seating Surface)

COMMITTEE DRAFT

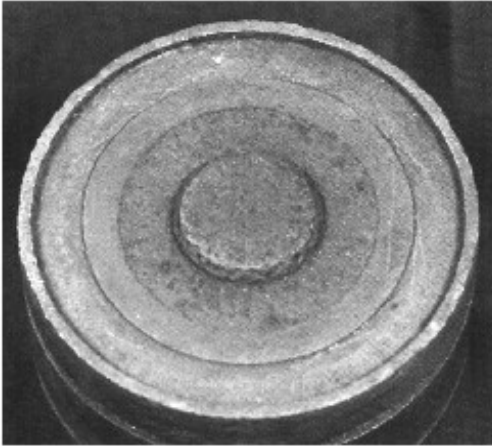

Figure 23 - Sulfide Corrosion on Carbon Steel Disc from Crude Oil Distillation Unit



Figure 24 - Chloride Attack on 18Cr-8Ni Steel Disc

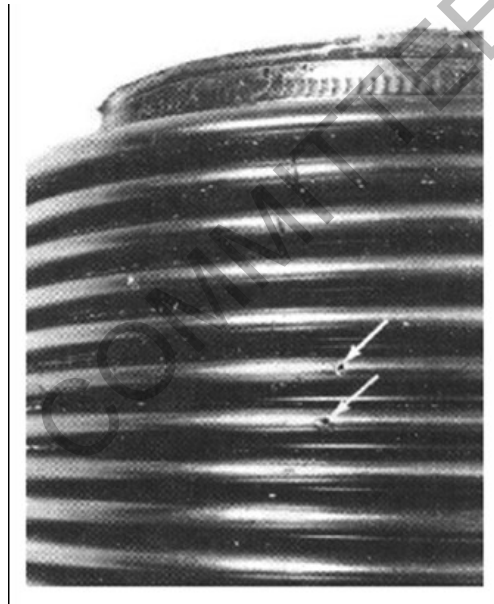

Figure 25 - Pit-type Corrosion on 18Cr-8Ni Steel Bellows



Figure 26 – Alloy 400 Rupture Disks Corroded in Sour Gas Service

Valve malfunction may also be due to sticking of the disc to the nozzle or the disc holder in the guide. This sticking may be caused by corrosion or galling of the metal or by foreign particles in the guiding surfaces. Foreign particles in the guiding surfaces tend to roll metal up, causing severe galling. The use of a bellows can keep the foreign particles away from the guiding surfaces. Sticking of valves illustrates a disc holder that is frozen in the guide as a result of corrosion, e.g. in sour gas service.

Corrosion may be slowed or mitigated by the selection of more suitable devices or device materials. Proper maintenance is also a consideration since a leaking valve allows fluids to circulate in the upper parts of the valve, which can contribute to the corrosion of its movable parts. Protective coatings as shown in Figure 27 may offer protection against corrosion in some services.

The use of a bellows can protect moving parts from the corrosive substance; especially in closed systems.

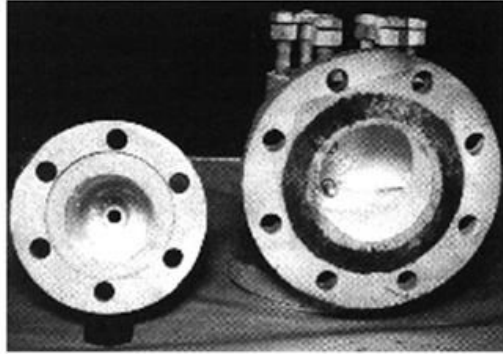

Figure 27 - Body and Bonnet Coated with Epoxy for Corrosion Protection

5.1.1 Examples of Preventative Actions for Corrosion

A rupture disk device installed on the inlet and/or outlet of a pressure-relief valve can provide added corrosion protection of the valve internals.

In many instances, valves with differing materials of construction can impede or altogether mitigate the effects of corrosion. The use of an O-ring or resilient seat in a pressure-relief valve may stop leakage past the seating surface and eliminate corrosion in the valve's working parts. However, O-ring elastomers may have a limited life under stress due to degradation caused by temperature, corrosive species, aging, or swelling. A bellows seal can be used to protect the spring and the bonnet cavity of the valve from the corrosive loading fluid.

5.2 Damaged Seating Surfaces

Imperfections in seating surfaces may contribute to improper valve action in service. To prevent leakage of the loading fluid, an optical precision on the order of three light beads/bands according to manufacturer's specifications should be maintained in the flatness of seating surfaces on metal-seated pressure-relief valves (see API 527).

- a) There are many causes of damaged valve seats in refinery or chemical plant service, including the following: Corrosion.
- b) Foreign particles introduced into the valve inlet which pass through the valve when it opens, such as mill scale, welding spatter or slag, corrosive deposits, coke, or dirt. The particles may damage the seat-to-nozzle contact required for tightness in most pressure-relief valves. The damage can occur either in the shop during maintenance of the valve or while the valve is in service.
- c) High inlet pressure drop may be caused by improper piping design or lengthy piping to the valve inlet or obstructions in the line and may cause a valve to chatter. The pressure under the disc may become great enough to open the valve. However, as soon as the flow is established, the pressure drop in the connecting piping may be so great that the pressure under the disc falls and allows the valve to close. A cycle of opening and closing may develop, become rapid, and subject the valve seating surfaces to severe hammering, which damages the seating surfaces, sometimes beyond repair. Figure 28 shows seating surfaces damaged by chattering and frequent fluctuations of pressure. Refer [to enee](#) API Std 520 Part II for further explanation of chatter.



Figure 28 - Seating Surface of Disc deformed by Chattering

- d) Improper handling during maintenance and/or transport, such as bumping, dropping, jarring, or scratching of the valve parts.
- e) Leakage past the seating surfaces of a valve after it has been installed. This leakage contributes to seat damage by causing erosion (wire drawing) or corrosion of the seating surface and thus aggravating itself. It may be due to improper maintenance or installation such as misalignment of the parts, piping strains resulting from improper support, or inadequate support of outlet piping. Other common causes of this leakage are improper alignment of the spindle, improper fitting of the springs to the spring washers, and improper bearing between the spring washers and their respective bearing contacts or between the spindle and disc holder. Spindles should be checked visually for straightness. Springs and spring washers should be kept together as a spring assembly during the life of the spring. Frequent operation too close to the PRV set pressure could cause leakage of process fluid across the PRV (simmer) and cycle the PRV resulting in seat damage.
- f) Improper blowdown ring settings. This can cause chattering in pressure-relief valves. The pressure-relief valve manufacturer should be contacted for specific blowdown ring settings.
- g) Severe oversizing of the pressure-relief valve for the relief loads encountered can cause the valve to cycle (open/close repeatedly), resulting in disc and nozzle seating surface damage. See Figure 29.

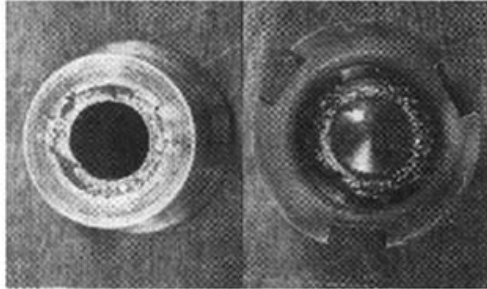

Figure 29 - Seating Surface of Disc Damaged by Frequent Operation of Valve Too Close to Operating Pressure

- h) Venting liquids across vapor trim PRVs can cause chatter/cycling/hammer effects with resultant damage.

5.3 Failed Springs

Spring failures occur in two forms. The first is a weakening of the spring, which causes a reduction in set pressure and the possibility of premature opening. The second is a mechanical failure (complete break) of the spring, which causes uncontrolled valve opening.

Although springs may weaken and fail due to the use of improper materials in high-temperature service, failed springs are almost always caused by corrosion. Surface corrosion and stress corrosion cracking are the most prevalent of this type of failure in refineries.

Surface corrosion attacks the spring surface until the cross-sectional area is not sufficient to provide the necessary closing force. It may also produce pits that act as stress risers and cause cracks in the spring surface and subsequent spring failure (see Figure 30).



Figure 30 - Spring Failure Due to Corrosion

Stress corrosion cracking (SCC) sometimes causes spring failure. The SCC damage mechanism is difficult to detect and predict before the spring fails. A brittle-type spring failure due to stress corrosion cracking is shown in Figure 31. Hydrogen sulfide (H_2S) frequently causes stress-corrosion cracking of springs (see NACE MR 0175 and NACE MR 0103 for material recommendations and guidance). Consult the manufacturer to select an appropriate spring in susceptible applications since the material strength, hardness and heat treatment of the spring can affect its resistance to stress corrosion cracking.

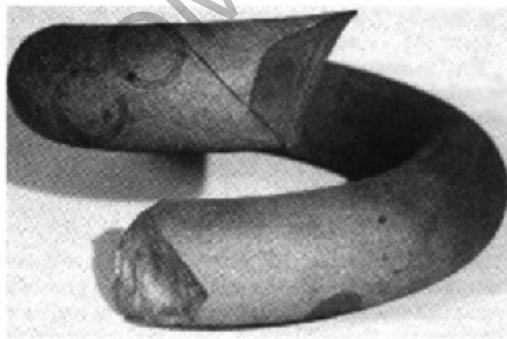

Figure 31 - Spring Failure Due to Stress Corrosion

5.3.1 Examples of Preventative Actions for Spring Corrosion

- a) Spring material that will satisfactorily resist the action of the corrosive agent may be used.
- b) The spring may be isolated by a bellows. Certain pilot operated pressure-relief valves have diaphragms or pistons that isolate the pilot spring from the process.
- c) The spring may be specially coated with a corrosion-resistant coating that can withstand the operating temperature and environment.

5.4 Improper Setting and Adjustment

Manuals by the valve manufacturer provide procedures for proper setting by indicating how to adjust their valves for temperature, backpressure, and other factors.

Setting a pressure-relief valve while it is in place on the equipment to be protected may be impractical and should be performed only after special consideration as noted in 6.3. Generally, direct acting spring loaded valves should be set in the valve maintenance shop while on appropriate test equipment. During inspection and repair, a properly designed test block facilitates the setting and adjusting of the pressure-relief valve (see Annex A).

Pressure-relief valves are designed and certified to operate in specific types of fluid media. Therefore, water, air, steam, or an inert gas such as bottled nitrogen is generally used as the testing medium in the shop, depending on the design of the valve being tested and the requirements of applicable design and testing codes. To ensure that the valve is opening, some overpressure should be carefully applied because an audible leak could otherwise be misinterpreted as the result of reaching the set pressure. However, most pressure-relief valves, particularly safety valves, produce a distinct pop at the set pressure, making misinterpretation unlikely. The size of the test stand is important since insufficient surge volume might not cause a distinct pop, and may cause an incorrect set pressure. Air, gas or vapor service valves should be set using air or inert gas. Steam service valves should be set using steam. Special attention is needed if the relief valve is placed in superheated steam service to compensate for temperature. Air may be used if suitable corrections are applied in place of steam. Liquid service valves should be set using water. See NB-23 part 3 section 4.5 for more details. It is important to note what audible or visual indication signifies the set pressure for a specific type of pressure-relief valve. This indication is defined by the manufacturer and is listed in NB-18 and manufacturer's manuals.

Consult the manufacturer for the proper technique for setting pilot operated pressure-relief valves on liquid as the water in the dome area and pilot assembly may create problems when placed in service.

Incorrect calibration of pressure gauges is a frequent cause of improper valve setting. To ensure accuracy, gauges should be calibrated frequently on a calibrated dead weight tester. The pressure range of the gauge should be chosen so that the required set pressure of the pressure-relief valve falls within the middle third of the gauge pressure range. Snubbers on pressure gauges are not generally recommended since they tend to clog and produce pressure lag. It may be desirable to use two test gauges during valve testing.

5.4.1 Many direct acting spring loaded pressure-relief valves have one or more internal rings that can be adjusted. The pressure-relief valve adjusting ring or rings will control the valve blowdown—the difference between the set pressure and the reseating pressure—and valve simmer, depending on the design of the valve being tested. To functionally test the pressure-relief valve and measure the blowdown, similar media properties of the service fluid and adequate flow capacities to fully cycle the valve are needed. Because the density and expansion characteristics of material handled through safety valves are variable and the volume of testing facilities is limited, it is usually impractical to adjust the valve rings and obtain a specific blowdown value on a maintenance shop test block. The rings should therefore be adjusted to obtain a pop on the valve test drum (see manufacturer's

maintenance instructions for this adjustment) and then inspected and readjusted for proper blowdown according to the manufacturer's recommendation. This should permit the best average performance characteristics of the valve when installed. Full understanding of terminology is important (see ASME PTC 25)

5.5 Plugging and Fouling

Process solids and contaminants such as coke, sand, or solidified products can sometimes plug various parts of the valve and connected piping. Additionally, monomer service can lead to polymer formation and plugging. All valve parts, particularly guiding surfaces and bellows, should be checked thoroughly for any type of fouling. See Figures 32, 33 and 34.

COMMITTEE DRAFT



Figure 32 - Inlet Nozzle Plugged with Coke and Catalyst After Nine Months in Reactor Vapor Line



Figure 33 - Outlet Valve Plugged with Deposits from Other Valves in Common Discharge Header



Figure 34 - Moving Parts of Valve Fouled with Iron Sulfide (FeS₂)

Sticking of pressure-relief valves may also be caused by poor alignment of the valve disc holder, which is usually due to debris on the contact surface between the guide and disc holder, or misalignment of a gasket at assembly. See Figure 35.



Figure 35 - Disc Frozen in Guide Because of Buildup of Products of Corrosion in Sour Oil Vapor Service

5.6 Galling

When galling of the metal in the guiding surfaces is not due to corrosion or foreign particles, it is often due to valve chatter or flutter caused by improper piping at the valve inlet or outlet or by severe over sizing of the valve. Galling may also occur if the system operates too close to the set pressure resulting in frequent relieving.

5.6.1 Examples of Preventative Actions for Galling

Correction of improper piping at the valve inlet or outlet will usually stop the action of chatter or flutter (See API STD 520 parts I and II). Improper finishing of the guiding surfaces can also result in galling caused by chatter or flutter. Consult the valve manufacturer for recommendations as this is potentially a design and manufacturing issue.

5.7 Misapplication of Materials

In general, the temperature, pressure, corrosion protection requirements, and the atmospheric conditions of the service determine the materials required for a pressure relieving device in a given service. Occasionally, severe corrosion or unusual pressure or temperature conditions in the process require special consideration. Manufacturers can usually supply valve designs and materials that suit special services. Catalogs have a wide selection of special materials and accessory options for various chemical and temperature conditions. Addition of a rupture disk device at the inlet and/or outlet of the valve may help prevent corrosion.

The H₂S attack on a carbon steel spring in Figure 30 and the chloride attack on an 18Cr-8Ni steel disc in Figure 24 exemplify the results of the misapplication of materials. When service experience indicates that a selected valve type or material is not suitable for a given service condition, an immediate correction that will ensure dependable operation should be made. Great care should be taken to record the identity of special materials and the locations requiring them. An adequate system of records should provide the information needed for the repair or reconditioning of valves in special service and for developing optimum purchase specifications.

5.8 Improper Location, History, or Identification

If not installed at the exact location for which it is intended a pressure-relief device may not provide the proper protection.

To assist in the identification of the devices and to provide information necessary for correct repairs and installation, historical records and specifications should be maintained and referred to when the devices are removed for inspection and repair. Most pressure-relief devices have an identifying serial or shop number placed on the device by the manufacturer or an identifying number tagged, stamped, or otherwise placed on the device by the user. Some users also stamp mating pipe flanges with device numbers. This identification specifies the location of the device and, by reference to the specification record, its limitations and construction.

5.9 Improper Handling

5.9.1 General

Improper handling can occur during shipment, maintenance, or installation. This improper handling of the relief valve can cause a change of the set pressure, damage lifting levers, damage tubing and tubing fittings, damage pilot assemblies or cause internal or leakage when the valve is in service. See Figures 36 and 37.

Valves are checked for tightness in the manufacturer's plant before they are shipped to the user. Valve tightness is sometimes checked by the user in the maintenance shop before initial use and usually checked after subsequent cleaning, repairing, or testing.

5.9.2 During Shipment

Most pressure-relief valves have a sturdy appearance that may obscure the fact that they are precise instruments with very close tolerances and critical dimensions. Accordingly, commercial carriers and/or maintenance transport trucks sometimes subject them to improper handling. This may cause a valve to leak excessively in service or during testing. This improper handling may also expose the valve inlet to dirt or other foreign particles that could damage the valve seating surface the first time the valve opens and cause leakage thereafter.

Pressure-relief valves should be braced and shipped in an upright position—this is especially true of large valves and valves with low set pressures. When large, low-pressure valves are allowed to lie on their sides, the springs or weights may not exert the same force all around the seating surfaces.

5.9.3 During Maintenance

Pressure-relief valve parts are precision items manufactured to extremely close tolerances. Improper handling can degrade these tolerances, destroy the basic valve alignment on which the fine, exacting performance characteristics of the device primarily depend. Both before and after repairs, improper handling of the completely assembled valve should be avoided. Mishandling of a PRV can affect the opening pressure and reseating pressure of the PRV during the pre-maintenance test or after it has been serviced and reset. This should be documented and proper handling procedures should be implemented. Before the valves leave the shop, valve inlets and outlets should be securely covered. Pressure-relief valves with lifting levers should not be moved or carried via the lever and consideration should be given to wiring the lever to the valve for stability during transportation.

Caution— ~~Lifting lever wiring is only used for transport and needs to be removed before installation.~~

Formatted: Caution, Indent: Left: 0.5", Hanging: 1"

Caution— Avoid exceeding the pressure rating of the bellows during a backpressure test as this may damage the bellows.

5.9.4 During Installation

Valve inlets and outlets should be securely covered before the valves leave the shop. When received for installation, inspection of the openings for foreign materials, shipping stays and damage should be performed.

API 2000 Section 3.7 should be utilized for the requirements for installation of tank venting devices.

Caution— Pressure-relief valves are often delivered with shipping stays that stabilize the valve during transport. Such stays shall be removed prior to installation.

Caution— Pressure-relief valves should be installed in a vertical orientation, with the disc of a direct acting valve or unbalanced member of a pilot operated valve oriented horizontally, such that the disc or unbalanced member moves upward as the valve opens. Other orientations may permit these parts to become misaligned in the guide. ASME BPVC Section VIII, Division 1, Appendix M, describes under what conditions an orientation other than vertical may be acceptable ~~tanks but the pallet is oriented vertically in the body.~~

Caution— There are weight loaded valve designs that can be installed on the sides of tanks. Weight loaded valves may have their weight shipped separate from the valve to protect the pallet seating surfaces during handling. These weights should be installed prior to commissioning the tank. Refer to API 2000 Section 3.7 for requirements for installation of tank venting devices.



Figure 36 - Improper Storage of Valves



Figure 37 - Example of Improper Storage of Valves

5.9.5 Improper Handling, Installation, and Selection of Rupture Disks

Rupture disk problems are often associated with improper handling, installation, and selection. The following should be considered.

- a) Ensure the rupture disk is installed in the proper orientation. Some reverse-acting rupture disks will open at a significantly higher burst pressure if installed in the reverse direction.

- b) Once a rupture disk is removed from its holder, the rupture disk should not be reinstalled. Installation in a holder can form an imprint on the disk. Once removed from its holder, it would be difficult to reinstall the disk perfectly in the same imprint. The most likely result will be premature failure below the intended burst pressure.
- c) Always follow the manufacturer's recommended torque settings when installing the rupture disk in the holder. An improper torque could affect the opening pressure of the disk and in some cases cause non-fragmenting disks to fragment.
- d) Touching the rupture disk surface could lead to localized corrosion leading to premature failures.
- e) Disks that become dented or otherwise damaged during installation or handling may open outside of their specified burst pressure tolerance or may not open completely on demand, thereby potentially restricting the relief path.
- f) Temperature can significantly affect rupture disk opening pressure for some materials. Specification of appropriate burst temperature should consider ambient heating or cooling if un-insulated and/or untraced. Consult the manufacturer and see API 520, Part I, for additional information.
- g) Rupture disks should be installed away from unstable flow patterns to avoid premature failures (see API 520, Part I, provides general requirements for installation of rupture disks).

5.10 Improper Differential Between Operating and Set Pressures

The differential between operating and set pressures provides seat loading to keep the pressure-relief valve tightly closed. Due to a variety of service conditions and valve designs, only general guidelines can be given for designing a system. ASME *BPVC* Section VIII, Division 1 and ASME *BPVC* Section VIII, Division 1, Appendix M, and API 520 are useful references. However, individual applications and experience may be relied on.

5.11 Improper Inlet/Outlet Piping Test Procedures

When hydrostatic tests of inlet/outlet piping are performed, blinds shall be installed. Otherwise, results such as the following might occur:

- a) The disc holder, guide, spring, and body area on the discharge side of the valve may become fouled;
- b) the bellows of a balanced pressure-relief valve may become damaged by excessive backpressure;
- c) the dome area and/or pilot assembly of a pilot operated pressure-relief valve may become fouled or damaged by the backflow of fluid;
- d) the test pressure may exceed the design pressure of the discharge side of the pressure-relief valve.

6 Inspection and Testing

6.1 Reasons for Inspection and Testing

Pressure relieving devices are installed on process equipment to release excess pressure due to operational upsets, external fires, and other hazards. These hazards are discussed in API 521. Failure of pressure relieving devices to function properly when needed could result in the overpressure of the vessels, exchangers, boilers, or other equipment they were installed to protect.

A properly designed, applied, and installed pressure relieving device that is maintained in good operating condition is essential to the safety of personnel and the protection of equipment during abnormal circumstances. The principal reason for inspecting pressure relieving devices is to ensure that they will provide this protection. Inspections of pressure-relief devices should determine the general physical and operating conditions of the devices, and ensure that their performance meets the requirements for a given installation. In making this determination, four types of inspections can be used. They are "shop as-received pop test", "shop inspection/overhauls", "field internal inlet and outlet piping inspections", and "visual on-stream inspections." Pretesting and post testing of the pressure relieving device should be included in the "shop inspection/overhaul." Each is discussed in the following sections.

6.2 Shop Inspection/Overhaul

6.2.1 General

Periodically, pressure-relief devices will be removed, disassembled, and inspected. These inspections are referred to as "shop inspection/overhaul" (although some, if not all of the work can be performed in the field). Also, while the device is removed, inlet and outlet piping should be inspected for the presence of internal deposits, and records should be kept of their condition and cleaning. If necessary, piping should be radiographed or dismantled for inspection and any cleaning to be performed.

~~After shop repair, the adjacent inlet/outlet piping of the pressure-relief device should be securely covered after inspection to avoid any foreign material entry and the covers should be removed when the pressure relief device is ready for installation after repair.~~

Caution— Covering the inlet/outlet piping connections should only be done after verifying that any connected equipment will not be adversely affected; e.g. subjected to excess vacuum.

Formatted: Caution

6.2.2 Safety

Before inspection and any repairs on pressure relieving devices are executed, general precautions should be taken to maintain the safety of the equipment protected by the devices, especially if the equipment is in operation. When inspection and repairs on an operating unit are required, the unit operations should be normal and the proper authority and permits for the work should be obtained.

Many pressure relieving valves have set pressures that exceed their outlet flange rating. If these valves are equipped with outlet block valves, the pressure-relief valve inlet block valve should be closed before the outlet valve is closed. Also, the pressure-relief valve body shall be vented immediately after the outlet isolation block valve is closed. This prevents high pressures from the pressure-relief valve inlet from possibly over-pressuring the pressure-relief valve body. Similar caution should be exercised when installing a blind in the pressure-relief valve outlet. Installation of drain valves between the inlet and outlet block valves and the pressure-relief valve should be considered, as shown in API 520, Part II. Unless the inlet is blinded, ensure the PRV outlet is continuously vented when the outlet valve is closed or the outlet is blinded. The inlet valve and PRV can leak causing the outlet to overpressure.

Before disconnecting pressure relieving devices, the connected piping and block valves should be checked to ensure that they are sufficiently supported. After reinstalling pressure-relief valves, the related piping should be checked to ensure that it is not imposing loads that would cause problems with the pressure-relief valve body such as distortion leading to in-service leakage, a change in set pressure or binding of the internal components leading to a stuck valve.

Some devices may trap hazardous toxic process material in bonnet cavities or dome cavities. Special steps during decontamination should be taken to minimize exposure of shop personnel.

6.2.3 Valve Identification

To minimize errors in the testing and handling of pressure-relief valves, each should carry an identifying tag, stencil, plate, or other means to show its company equipment number. This number readily identifies the device's unit, the equipment that the device should be installed on, the device's set pressure, and the date of its last test (see Figures 38-40 for examples of an identifying tag). If a relief device cannot already be easily and correctly identified by a marking on it, it should be marked and identified as described above before it is removed from its equipment. Also see ASME *BPVC* Section VIII, Division 1, Paragraph UG-129, for instructions on marking nameplates of pressure relieving devices. It is recommended that the original manufacturer's nameplate should always remain on the pressure-relief valve. Caution should be taken not to paint over the tag.

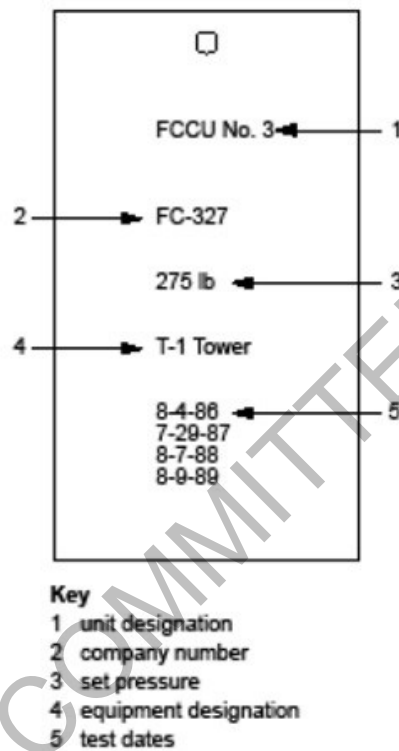

Figure 38 - Identification Tag for Pressure Relieving Device

UV	NB	ANDERSON GREENWOOD CROSBY, STAFFORD, TX.			
		SIZE STYLE	2J3 JOS-E-15-J		
SHOP NO.	82314000	SET PRESS. PSI	150	CDTP PSI	140
SER. NO.	06-4980	BP PSI	10	TC PSI	
CAP.	3245 SCFM			OVER PRESS.	10%
CC 2203		Tag PRV-1234			

Figure 39 - Identification Tag for Pressure Relieving Device

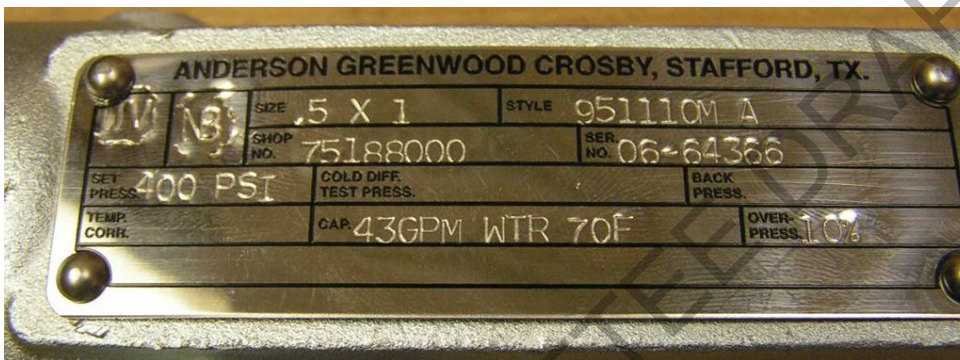

Figure 40 - Identification Tag for Pressure Relieving Device

6.2.4 Operating Conditions Noted

An operating history of each pressure-relief valve since its last inspection should be obtained and should include pertinent information such as the following:

- information on upsets and their effect on the valve,
- the extent of any leakage while in service,
- any other evidence of malfunctioning,
- whether any rupture disks under the pressure-relief valve have been replaced.

In addition, records of valve performance during previous runs should be checked to determine whether changes are needed in the valve materials or components or in the inspection interval.

6.2.5 Removal of Device from System in Operation

Caution— The removal of a pressure-relief device from equipment in operation should be planned to minimize its duration. **Most pressure-relief valves have a sturdy appearance that may obscure the fact that they are precise instruments with very close tolerances and critical dimensions. Exercise caution on removal so not to invalidate the as-received pop test.**

The precautionary steps in 6.2.1 should be followed. Before a pressure-relief valve is inspected and/or repaired while equipment is in operation, the following precautions should be taken.

- a) Only an authorized person should isolate a relief device by closing any adjacent block valves upstream or downstream (see ASME *BPVC* Section VIII, Division 1, Appendix M). This may require providing or identifying alternate relief protection.
- b) The space between the relief device and any adjacent block valve should be vented to a safe location to release trapped loading fluid and to determine whether the block valve is holding.
- c) If a block valve is not installed on the downstream side of a relief device discharging into a common header, a blind or other suitable isolation should be applied to prevent discharge through the open outlet pipe in case one of the other relief devices opens, prevent air ingress if the header is operating below atmospheric pressure, and/or prevent reverse flow if the header is operating above atmospheric pressure
- d) In situations where a relief device is to be serviced in place, a blind should be inserted or other positive isolation device should be in place upstream/downstream of the pressure-relief device before a pressure-relief device is even partially disassembled.
- e) When a relief device is removed, blinds or other suitable covers should be placed over open piping/valves to protect seating surfaces and prevent entry of foreign material.

Caution – The potential for damage caused by blocking the vent should be considered prior to installing covers over exposed vents. (e.g. vacuum effects)

- f) If there is a rupture disk device associated with the pressure-relief valve and the rupture disk is removed from its holder as part of the accompanying relief valve removal, manufacturer recommendations should be followed for disk replacement since the disk could easily be damaged and could fail to burst at the proper pressure if reused.
- g) All blinds should be removed after the relief device has been reinstalled following inspection, repair, or replacement.
- h) The block valves on the inlet and outlet should be opened and locked or car sealed in that position. Figure 41 shows a pressure-relief valve installation with the block valves sealed open. Block valves used with relief devices should be verified to **have sufficient flow area be full-port** to prevent flow restriction and excessive pressure drop. In cases where there are installed spare pressure-relief valves, the inlet block valve of the spare should be closed. The outlet side should be protected from overpressure caused by leakage through the inlet block and the relief valve. The outlet block valve could either be locked open or car sealed, or positive means of venting could be provided if the outlet is shut. Consider installing the block valves with the valve stems in the horizontal position. . For devices in highly corrosive service (e.g., HF main acid service), consider methods to verify that the valve is fully opened.
- i) A pressure-relief valve should not be considered as a positive isolation valve when the equipment that it is protecting is out of service. If the pressure-relief valve remains in place during this time then proper isolation block valve closure operations should take place.

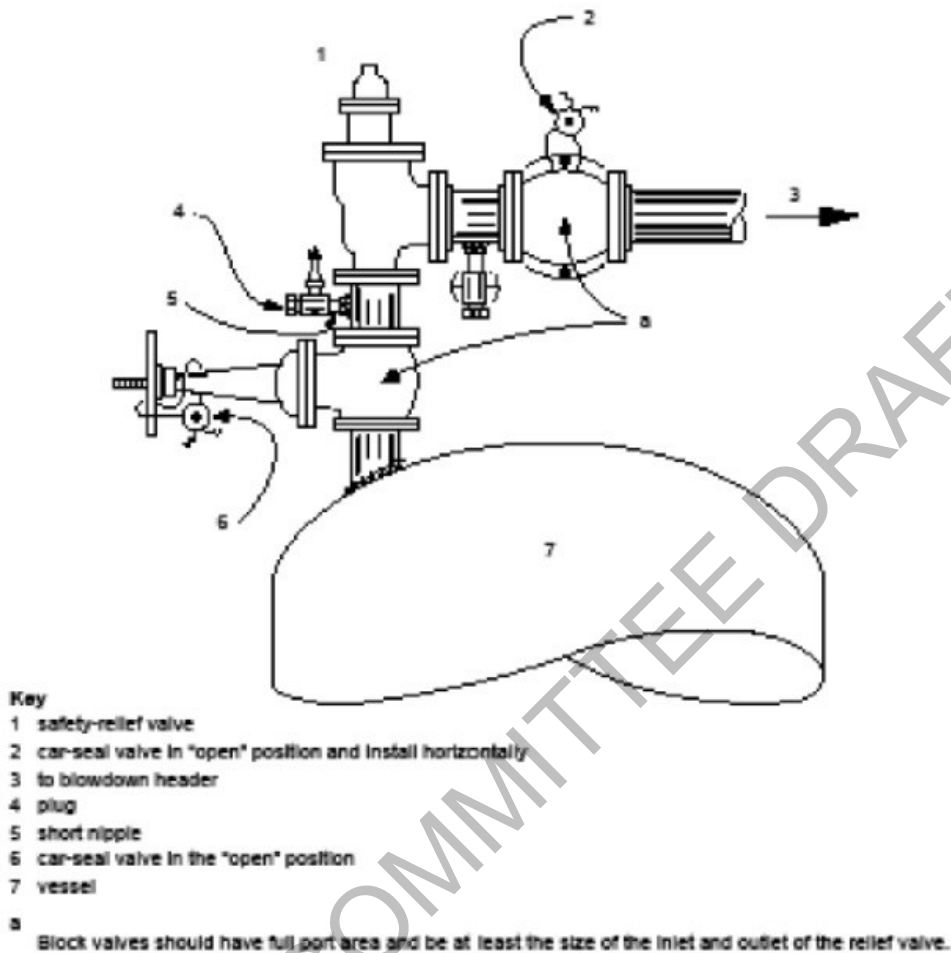

Figure 41 - Block Valves on Pressure-relief valve Inlet and Outlet Sealed Open

6.2.6 Initial Inspection

Many types of deposits or corrosion products in a pressure-relief valve may be loose and may drop out during transportation of the valve to the shop for inspection, testing, maintenance, and resetting. As soon as a valve has been removed from the system, a visual inspection should be made. Figure 42 shows one example of sulfur deposits in the outlet of a PRV. When fouling is a problem, it may be prudent to collect samples for testing and to record deposit locations and appearances. Any obstructions in the valve should be recorded and removed.

Caution— Valves that have been exposed to materials hazardous to humans or that may contain material that could be an auto-ignition source should be handled with special precautions.

Some precautions to follow when inspecting valves exposed to hazardous materials include the following.

- a) Evaluate the potential for the valve to contain pyrophoric (e.g. Iron Sulfide (FeS)) or reactive materials and determine the appropriate precautions for the material involved.
- b) Valves in acid or caustic service should be handled very carefully adhering to rigorous handling procedures prior to pre-pop testing of the "as-removed" PRV. After pre-popping, PRV's should be immediately neutralized.. Even after neutralization, the safety precautions indicated by the Material Safety Data Sheets/Safety Data Sheet (MSDS)/(SDS) and other appropriate sources of handling information shall be taken.

Rupture disks are sometimes used to protect other pressure relieving devices from corrosion. Normally in this case, a rupture disk cannot be inspected without being removed. Therefore, inspection of the disk should be part of the routine developed for inspection of the pressure-relief valve.

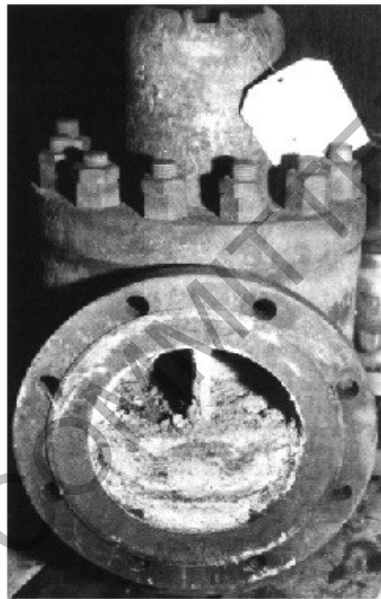

Figure 42 - Sulfur Deposits in Body of Valve

6.2.7 Inspection of Adjacent Inlet and Outlet Piping

When a pressure-relief device is removed from service, the upstream and downstream piping is often open and available for inspection. However, where block valves are closed to enable removal of relief devices from equipment during operation, it is usually impossible to directly inspect this piping. In potential fouling services, profile radiography should be considered for piping upstream

or downstream of PRV's looking for locations where potential fouling deposits may collect that could restrict flow or cause corrosion under deposits.

Inspection of the piping at the pressure-relief device will often indicate the condition of the process piping whose interior is not visible. Piping should be checked for corrosion, indications of thinning, and deposits that could interfere with device operation. The character of the deposits may indicate the cause of any leakage from the valve in a closed system.

6.2.8 Transportation of Pressure Relieving Devices to Shop

The improper shipment and transport of pressure-relief devices can have detrimental effects on device operation. Pressure-relief devices should be treated with the same precautions as instrumentation, with care taken to avoid improper handling or contamination prior to installation. Improper handling during transportation to the repair shop may also result in inaccurate "as-received" set pressure tests, which may cause improper adjustments to relief device inspection intervals.

The following practices are recommended.

- a) Flanged valves should be securely bolted to pallets in the vertical position to avoid side loads on guiding surfaces.
- b) Careful handling of threaded valves during transport in a manner to avoid damage to threaded connections.
- c) Valve inlet and outlet connection, drain connections and bonnet vents should be protected during shipment and storage to avoid internal contamination of the valve. Ensure all covers and/or plugs are removed prior to installation. Pilot operated valve tubing should also be protected from damage.
- d) Lifting levers should be wired or secured so they cannot be moved while the valve is being shipped or stored. These wires should be tagged for removal by the manufacturer or repair shop and removed before the valve is placed in service.
- e) Rupture disks should be handled by the disk edges. Any damage to the surface of the disk can affect the burst pressure.

6.2.9 Shop Inspection, Testing, Maintenance and Setting of Direct Acting Spring Loaded Pressure-relief valves Used for Unfired Pressure Vessels

6.2.9.1 Determining "As-Received" Pop Pressure

Wherever possible, as-received pop testing should be conducted prior to cleaning in order to yield accurate as-received pop testing results which will help establish the appropriate inspection and servicing interval. Cleaning of deposits prior to as-received pop testing can remove deposits that would have prevented the valve from opening at set pressure. Pop testing in the as-received condition for valves in acid/caustic/toxic services can be accomplished by utilizing a pop test stand built on site in the area where the valve is installed; or by contracting with a service supplier that has a portable test stand that can be brought on site. Check that the seals are intact on the pressure set screw cover and blowdown ring screw cover. Before the valve is dismantled, the set pressure of the valve should be obtained. Generally the pressure-relief valve is mounted on the test block, and the inlet pressure is slowly increased. The pressure at which the valve relieves is recorded as the "as-received" pop pressure.

If the valve initially opens at the CDTP, no further testing to determine the "as-received" pop pressure is needed. If the initial pop is at a pressure higher than the CDTP, the valve should be tested a second time. If it then pops near the CDTP, the valve may not have originally popped at the CDTP because of deposits. If on the second try the valve does not pop within the tolerances allowed by the ASME *BPVC*, either the valve setting may have been originally in error or it changed

during operation. Pressure-relief valves that do not pop at inlet pressures of 150 % of CDTP should be considered as stuck shut. If the initial pop is at a pressure lower than the CDTP, the spring may have become weakened, the valve may have been set improperly at its last testing the seat may have been damaged, or the setting changed during operation. It is the first test that is recorded as the "as-received" pop pressure. This "as-received" pop pressure is used in determining the inspection interval.

Caution— If the valve is extremely fouled and dirty when received and the "as-received" actuation of the valve may damage the valve's seats, the user may waive the "as-received" test and instead reduce the inspection interval. After reducing the valve's inspection interval, the valve should be clean at the next inspection. If it is not clean, the inspection interval should again be shortened or other measures should be taken to reduce the fouling.

6.2.9.2 "As-Received" Pop Test Results

To ensure the reliable operation of relief valves, it is important to understand the root cause of "as-received" pop test failures in order to determine if any corrective actions are necessary. Relief valves can fail the "as-received" pop test in a number of ways.

- Stuck shut or fails to open
- Device partially opens
- Opens above set pressure tolerance
- Leakage past device
- Spurious/premature opening
- Device stuck open

The owner-user should define the criteria which constitute an "as-received" pop test failure. The owner-user may define criteria for investigation of failures based on "as-received" pop test pressure as a percentage of set pressure and may specify different levels of investigation rigor depending on the severity of the failure and criticality of the application. For example, in API RP 581 a relief valve that does not pop at 130% of the set pressure is considered a failure to open. As a default criterion for a valve being stuck shut, a number of companies use 150% of the set pressure beyond which the valve is classified as stuck shut if it does not pop, and the test is discontinued.

Caution— The limiting test pressure to which the valve is subjected may not be as high as the values stated above. Some end users and repair organizations may use lower values due to concerns regarding damage to the valve, test equipment or personnel injury. This becomes more significant at higher set pressures.

The investigation should focus on the development of a corrective action plan that addresses the failure mode observed and may include a reduction in the relief valve inspection interval and/or design changes related to the installation, material selection, pressure-relief device selection, etc.

6.2.9.3 Visual Inspection

After the "as-received" pop test, a valve should be visually inspected to estimate its condition. This inspection should be made by the authorized repair shop's pressure-relief valve repair mechanic unless unusual corrosion, deposits, or conditions are noted in the pressure-relief valve. The results of this inspection should be noted on appropriate forms. Points that should be checked may include but are not limited to:

- a) the flanges, for evidence of pitting, roughening, or decreases in the width of seating surfaces;

- b) the springs, for evidence of corrosion or cracking and for the correct pressure range at the valve's operating pressure and temperature;
- c) if the valve is of the bellows type, the bellows for evidence of corrosion, cracking or deformation;
- d) the positions of the set screws and openings in the bonnet;
- e) the inlet and outlet nozzles, for evidence of deposits of foreign material or corrosion;
- f) the external surfaces, for any indication of a corrosive atmosphere or of mechanical damage;
- g) the body wall thickness;
- h) valve components and materials, for a match with the information on the identification tag and specification card;
- i) the pilots and associated parts.

Caution— When unusual corrosion, deposits, or conditions are noted in the pressure-relief valve, an inspector representing the user should assist in the inspection.

Caution— If the pressure-relief valve is from equipment handling hazardous materials, caution should be exercised during the inspection.

6.2.9.4 Dismantling of Valve

After the valve is received and its testing and initial visual inspection is completed, it may require dismantling for a thorough shop inspection and repair. If the valve has been tested at the appropriate interval set in accordance with API 510, and the guidance in 6.2.9.1 for determining the "as-received" pop pressure is followed, and the results of the "as-received" test show that the valve tests properly, then disassembly of the valve for further inspection may not be required, unless restoration of the valve to the "as new" condition is required.

When appropriate, valves should be carefully dismantled in accordance with the manufacturer's manuals and recommendations. Before dismantling valves in light hydrocarbon service, thoroughly clean the valve with chemicals that are compatible with the valve material to avoid a flash due to sparks created by the dismantling operations. Proper facilities should be available for segregation of the valve parts as the valve is dismantled. At each stage in the dismantling process, the various parts of the valve should be visually inspected for evidence of wear and corrosion. The valve spindle, guide, disc, and nozzle require visual inspection. The bellows in balanced valves should be checked for cracks or other failures that may affect performance.

6.2.9.5 Cleaning and Inspection of Parts

To keep the parts of each valve separate from those of other valves, the valve parts should be properly marked, segregated, and cleaned thoroughly. The valve parts that most often require cleaning are the nozzles, springs, disc holders, guides and discs. Deposits that are difficult to remove should be cleaned with solvents, brushed with wire, glass bead blasted or carefully scraped.

After being cleaned, check each part carefully with the proper equipment for measuring valve dimensions, with frequent reference to the proper drawings and literature.

The components should be checked for wear and corrosion. Seating surfaces on the disc and nozzle should be inspected for roughness or damage, which might result in valve leakage. They should also be checked with appropriate seat gauges to assure that neither wear nor previous machining has caused the seat dimensions to exceed the manufacturer's tolerances. Seat flatness can be checked with suitable lap rings recommended by the manufacturer, optical flats, or other suitable inspection devices. The springs should be checked for the proper rate. The springs should also be checked for cracking or deformation. The fit between the guide and disc or disc holder should be checked for proper clearance and visually inspected for evidence of scoring. The nozzle should be checked for obstructions and deformation. Bellows should be checked for leaks, cracks, or thin spots that may develop into leaks. In addition, if the bellows has collapsed, it has probably been subjected to backpressure greater than its design pressure. High backpressure may be due to downstream restrictions that are created by deposits, or to higher relief flows than used in the original design. The cause should be determined, and corrective action should be taken.

6.2.9.6 Reconditioning and Replacement of Parts

Parts that are worn beyond tolerance or damaged should be replaced or reconditioned. Damaged springs, bellows and single-use components, even those that are apparently undamaged, should be replaced. All soft goods, even those that are apparently undamaged, should be replaced. Spare parts for a particular pressure-relief valve should be obtained from its manufacturer. The valve body, flanges, and bonnet may be reconditioned by means suitable for repairs to other pressure-containing parts of similar material. If evidence of wear or damage is found on the disc or nozzle, their seating surfaces may be machined or lapped. Follow the manufacturer's recommendations when reconditioning valve parts.

6.2.9.7 Reassembly of Valve

After the valve has been inspected and its parts have been reconditioned or replaced, it should be reassembled in accordance with the manufacturer's instructions. The nozzle and disc seating surfaces should not be oiled. Clearances between assembled parts should be checked. In accordance with the manufacturer's instructions, the spring should be adjusted to set as close to the desired set pressure as possible. Blowdown rings should be set in accordance with the manufacturer's recommendations for the appropriate vapor or liquid service, and the settings should be noted for future reference. Because most test blocks do not have enough capacity to measure the actual blowdown, manufacturer's recommendations and past performance should be evaluated to estimate any necessary adjustment.

6.2.9.8 Setting of Valve Set Pressure

After the valve has been reconditioned and reassembled, its spring should be adjusted for the last time to ensure the valve will relieve at the required CDTP. Although test procedures will vary with local plant practice, the valve is generally mounted on the test block and air or water pressure is increased slowly until the valve relieves. The manufacturer's recommendations should be used to guide the adjustment of the spring to the correct setting. If a new set pressure is required, the manufacturer's limits for adjustment of the spring shall not be exceeded. If necessary, a different spring should be provided.

After the valve has been adjusted, it should be actuated at least once to prove the accuracy of the setting. Some manufacturers recommend a valve be actuated (popped) at least three times, as the first cycle helps align all of the components after the overhaul while the successive cycles verify the set pressure. Normally, for ASME Section VIII valves, the deviation of the as-found set pressure from the nameplate set pressure should not exceed ± 2 psi (± 15 kPa) for pressures less than or equal to 70 psi (500 kPa) or ± 3 % for pressures greater than 70 psi (500 kPa) [see ASME *BPVC* Section VIII, Division 1, Paragraph UG 134(d)(1)]. For pressure-relief valves that comply with ASME *BPVC* Section VIII, Division 1, Paragraph UG 125(c)(3), the deviation shall not be less than 0 % or greater than +10 %. Any allowance for hot setting should be made in accordance with the manufacturer's data. Any adjustment to the CDTP required to compensate for in-service

backpressure, service temperature, or test media should be made in accordance with the manufacturer's or user's valve specification data.

Where the pressure-relief valve set pressure is below 15 psig, such as a pilot operated pressure-relief valve on an API 620 low pressure storage tanks, the +/- 2 psi tolerance may be excessive and could substantially exceed the tank's pressure rating. The owner/user should specify the set point tolerance and required gauge precision and range to be used during the set pressure verification.

Follow the valve manufacturer's recommended testing procedure when the pressure-relief valve is tested with water. Typically, the pressure will be raised slowly to the required setting. The discharge should be observed for evidence of leakage, or the test gauge should be observed for a momentary drop in pressure. A small continuous stream of water from the valve discharge usually indicates attainment of the CDT. The pressure at which the valve releases should be within the tolerances noted above before the valve is approved for service. Refer to NB-18 or the manufacturer's maintenance manual for the definition of set pressure for liquid service valves.

Pressure-relief valves set with water may need to have the water drained and the valve dried prior to installation to assure proper function in service.

6.2.9.9 Checking Valve for Tightness

Once the valve is set to pop at its CDT, it should be checked for leakage. On the test block, it can be tested for seat tightness by increasing the pressure on the valve up to the manufacturer's specified simmer pressure (oftentimes this is 90 % of the CDT) and observing the discharge side of the valve for evidence of leakage. See Figure 43 or reference API 527 for allowable leakage rate.

Where applicable, the bonnet, bellows, gasketed joints and auxiliary piping/tubing should be inspected for leakage.

Caution – For closed systems, the valve should be backpressure tested to check for leakage at bonnet to body connection, bellows, bellows' gasket (if applicable), at the cap to bonnet connection and at full nozzle to body connection (Refer ~~to~~ ASME Section VIII, Division I, UG--136).

Leakage from in-service pressure-relief valves should be minimized due to the potential hazards to the environment, personnel, and equipment. Leakage may lead to fouled and inoperable valves and as well as potential product loss.

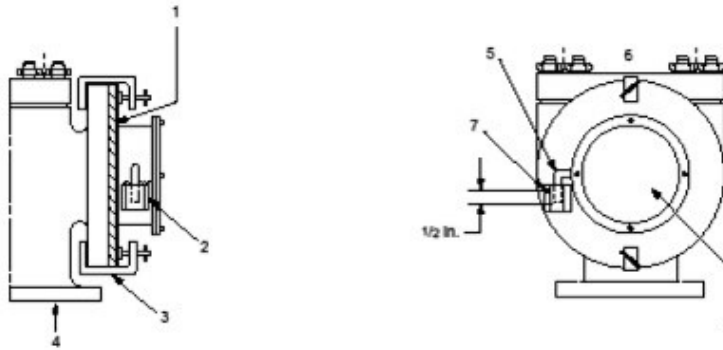

Key

- 1 soft rubber gasket attached to face of detector to prevent leakage
- 2 weld cup to detector
- 3 C clamp
- 4 air pressure
- 5 outlet tube—cut end smooth and square
- 6 safety valve
- 7 water level control hole—maintain 1/2 in. from bottom of tube to bottom of hole
- 8 waxed paper to relieve pressure if valve opens during test

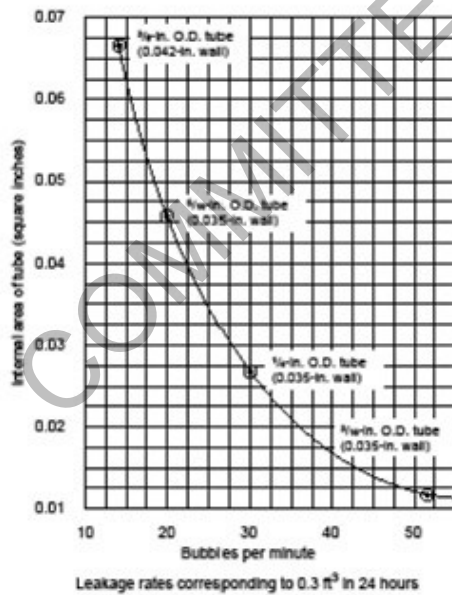

Figure 43 - Safety Valve and Relief Valve Leak Detector

6.2.9.10 Completion of Necessary Records

All necessary records should be completed before a valve is placed back into service. By helping to determine when to replace the components of the valve and when to retire it, the records are critical to its effective future use. They form the historical record of the conditions and services under which the valve operated. Retention of maintenance and test records may be required by governmental regulations. See Annex B for example forms. For an explanation of nameplate terms required by repair work, see API 526.

6.3 Inspection, Testing, Maintenance, and Setting of Direct Acting Spring Loaded Valves on Equipment

It is generally more economical and effective to perform a shop inspection/overhaul in the shop at the required intervals than on its equipment. However, when a valve operates in non-fouling service, experience may indicate that inspection of the valve while on the equipment is safe and suitable. When suitable safety precautions have been taken (see 6.2.2), the inlet and outlet block valves may be closed, and the bonnet of the valve may be removed for immediate inspection, testing, and any minor repairs by a qualified person. When major repairs are indicated, the valve should be sent to the shop.

In certain cases, the valve may be tested for set pressure and leakage with an inert gas testing medium through a bleeder. This method is inferior to the test block procedure discussed in Annex A. It yields inaccurate test results for metal-seated valves unless sufficient upstream volume is provided that allows the valve to open to about half of full lift. If the available upstream volume is not sufficient to cause the valve to attain about half lift, the use of a restricted lift device is recommended to avoid damaging the valve from the impact loading caused by too rapid of a closure.

A valve may be tested on-stream with a lift assist device that will determine the set pressure of the valve. These devices apply an auxiliary lifting load to the valve disc holder and spindle and, in conjunction with lifting the valve, incorporate a method for determining the opening of the valve and the load applied at the point of opening. Numerous technologies are used for determining the opening point and correlation of the applied load. These technologies range from simple audible notification, to software-based data analysis, displacement, or acoustic sensors. The set pressure of the valve is computed by dividing the load at opening by the valve seat area and then adding the value of inlet pressure. Data output ranges from a summary of load, inlet pressure and set pressure to graphing of measured and calculated values such as applied load, valve lift, and inlet pressure. This method may or may not be accepted by local jurisdictions as a valid method of either verifying or adjusting valve set pressures.

There are potential hazards to consider when applying the lift assist test method:

- a) potential failure of the rupture disk in rupture disk/ valve combinations;
- b) possible introduction of foreign material into the valve seating area which may result in mechanical damage and/or leakage through the valve upon reset;
- c) possible release of process material to atmosphere;
- d) potential failure of the bellows, in a bellows equipped valve, will cause release of process to atmosphere through the valve's bonnet openings;
- e) most devices are electronic and as such should be analyzed for their suitability to hazardous environments;

- f) the valve may not reseal tight following the test necessitating actions appropriate for valve leakage;
- g) testing with the inlet pressure near the set point of the valve may cause the valve to open necessitating a reduction in operating pressure or a mechanical device to close the valve.

Caution— This method of checking the set pressure and functioning of a safety valve identifies the opening pressure and should not be considered a routine activity for determining the integrity of the pressure relieving device. The lift assist test method of checking the set pressure of a pressure-relief valve does not satisfy the need to check for inlet/outlet line fouling or to remove a valve for physical inspection and verification that all of its components are in satisfactory and safe working condition. The lift assist test method also does not verify the valve blowdown setting and seat leakage at 90% of set pressure of the valve.

6.4 Inspection, Testing, Maintenance, and Setting of Direct Spring Operated Safety Valves Used on Fired Pressure Vessels

Although safety valves on steam boilers are similar in construction and operation to relieving devices on process equipment, they are designed and installed in accordance with local, state, and federal regulations and power codes. Company practices may be used to establish an inspection policy if they do not conflict with or compromise the intent of any regulatory requirements.

Boiler safety valves may be welded to the boiler and therefore cannot be practically removed for testing or maintenance. Boiler safety valves can be tested periodically by raising the steam pressure until the valve actuates. Precision-calibrated pressure gauges should be used to determine the pressure at which the valve actuates. The accumulation and blowdown should also be noted. ASME *BPVC* Section I also requires the boiler safety valves have a substantial lifting device by which the valve disc may be lifted from its seat when the working pressure on the boiler is at least 75% of the set pressure, so that checking for the freedom of moving parts to operate is feasible. Extreme caution should be used when operating these manual lifting devices and many users prohibit their use and lock wire them closed.

For flanged boiler safety valves, in lieu of being tested on the boiler, some safety valves may be removed and tested at regular intervals, which may be determined by local jurisdictional requirements. Usually, testing for set pressure with steam is required.

Some regulatory agencies allow on-stream testing of steam safety valves with a lift assist device that will determine the set pressure of the safety valve. These devices apply an auxiliary lifting load to the safety valve and, in conjunction with lifting the valve, incorporate a method for determining the opening of the safety valve and the load applied at the point of opening. Numerous technologies are used for determining the opening point and correlation of the applied load. These technologies include simple audible notification, to software-based data analysis, displacement, and acoustic sensors. The set pressure of the valve is computed by dividing the load at opening by the valve seat area and then adding the value of inlet pressure. Data output ranges from a summary of load, inlet pressure and set pressure to graphing of measured and calculated values such as applied load, valve lift, and inlet pressure.

Caution— This method of checking the set pressure and functioning of a safety valve identifies the opening pressure and should not be considered a routine activity for determining the integrity of the pressure relieving device. The lift assist test method of checking the set pressure of a pressure-relief valve does not satisfy the need to check for inlet/outlet line fouling or to remove a valve for physical inspection and verification that all of its components are in satisfactory and safe working condition. The lift assist test method also does not verify the valve blowdown setting. Testing with the inlet pressure

near the set point of the safety valve may cause the valve to open necessitating a reduction in operating pressure or a mechanical device to close the valve.

6.5 Inspection, Testing, Maintenance, and Setting of Pilot operated Pressure-relief valves

Inspection, testing, maintenance, and setting of the pilot mechanism may be handled separately from the main valve. With test connections, the set pressure of some types of pilots may be accurately tested while the valve is in service. If there is no block valve under the main valve, the pilot mechanism may be inspected and repaired only while the vessel is out of service.

Caution – It is recommended that a pilot valve be removed for maintenance since actuation of the pilot mechanism does not necessarily mean the main relief piston will actuate.

Due to the variety of pilot operated valves available, the valve manufacturer's recommendations for inspection, repair, and testing should be consulted and followed.

Many of the considerations that apply to other direct acting spring loaded valves also apply to pilot operated valves. The following is a list of additional considerations that apply to pilot operated valves:

- a) inspect soft goods (O-rings, diaphragms, gaskets);
- b) check for plugging in pilot assembly and external tubing;
- c) check for material trapped in main valve dome area;
- d) check all tubing fittings for leakage;
- e) inspect the pressure sensing device and its orientation. A pressure sensing device in the wrong orientation can cause the pilot to not load the main valve;
- f) check pilot valve vent line or bug vent for any plugging or obstructions.

6.6 Inspection, Testing, Maintenance and Setting of Weight-loaded Pressure and/or Vacuum vents on Tanks

The inspection, testing, maintenance, and setting of relieving devices on pressure storage tanks is similar to those of direct acting spring loaded valves on process equipment.

Pressure and/or vacuum vent valves (PVRV/s) on atmospheric tanks are designed to vent air and vapor from the tank during filling operations and to admit air when the tank is drawn. Pressure and/or vacuum vent valves are in almost continuous service. They are prone to failure by sticking. Periodic examination may detect this condition. Where temperatures fall below freezing, the devices may need to be checked during the cold period to ensure that the discs (normally called pallets) do not stick because of icing. These pallets are usually weight loaded. The inspection of each vent valve in place should include the checking of the discharge opening for obstructions. The top of the valve should be removed and the pallets checked for freedom of movement. Seats should be checked to ensure that there is no sticking or leakage, since the forces actuating the valve are small. If the valve has a flame arrester on the inlet nozzle, it should be inspected for fouling or plugging. If necessary, it should be removed for cleaning.

Caution - Freezing of a PVRV can occur in tanks equipped with heating coils whereby excessive vapor can condense and freeze in the vacuum valve. This can necessitate the use of form-fitting heaters for the PVRV.

Recommended Steps for Inspection

- a) The discs (normally called pallets) of the devices should be checked for sticking. If the pallets are stuck, the product's effect on the seal material and on the pallet material should be investigated. If necessary the seal material and the pallet material should be changed.
- b) The pallet should be checked and maintained. Once a pallet is removed, it should be cleaned. If there is any reason to suspect the mass of the pallet has been changed (tampering, corrosion, etc.) its mass should be determined. Check the mass against the mass required for the correct relieving pressure of the device. The mass of the pallet and its weights divided by the area of the opening covered by the pallet will determine the pressure or vacuum setting.
- c) If the mass is not correct, mass should be added or removed until the correct mass has been achieved. Be sure that any additional mass added does not restrict the lift of the device below the manufacturer's design. Pallet condition and serviceability should be checked, and unusable pallets should be replaced.
- d) The seats and pallets should be checked and cleaned.
- e) The gaskets at the pallet seating areas should be checked and, if necessary, replaced.
- f) The protective screens should be checked for serviceability and, if necessary, renewed.
- g) If the weights are positioned on a moment arm attached to the seating area, then hinges and hinge pins should be checked for operability and, as necessary, serviced, lubricated, and replaced.
- h) Any special coating used internally or externally on the body should be checked and, if unserviceable, replaced.
- i) The hood should be inspected and, if unserviceable, replaced.
- j) The bolts should be checked and, as required, replaced.
- k) Reassembly and final operability check to assure pallets are free to move.

7 Inspection and Replacement of Rupture Disk Devices

7.1 Rupture Disk Removal and Replacement

When rupture disks are removed from the rupture disk holder they are generally replaced because the integrity or remaining useful service life of the disk cannot be determined by visual or mechanical inspection. Manufacturer recommendations should be followed for disk replacement when removed from the holder. A rupture disk that is installed in a pre-torque rupture disk holder can be removed as an assembly for visual inspection, and reinstalled without affecting the remaining service life if the pre-torque cap screws or bolts were not loosened. See Section 5.9.5.

Rupture disk replacement should be done on a schedule based on the manufacturer's recommendation, consequence of nuisance releases, past experience of the specific rupture disk installation, and the relative cost of an unplanned maintenance shutdown.

7.2 Examples of Rupture Disk Failure Modes

There are generally three failure modes that affect useful service life of the rupture disk:

7.2.1 Fatigue –

As a mechanical device that is designed to fail, the rupture disk is sensitive to the stress applied from pressurization and thermal cycles. As the magnitude and number of stress cycles increases, the probability of a premature failure due to fatigue increases. Parameters to consider include:

- a) Rupture disk type
- b) Maximum operating pressure relative to the marked burst pressure (operating ratio)
- c) Pressure cycling (wide swings, positive to negative, frequency, etc.)
- d) Thermal cycling

See Figure 44 and Figure 45.



Figure 44 - Operating Ratio Exceeded then Subjected to Vacuum



Figure 45 - Operating Ratio Exceeded – Tabs Are Stretched

7.2.2 Corrosion –

The burst pressure controlling elements of the rupture disk are often rather thin and therefore susceptible to changes in mechanical strength due to corrosion. Corrosion failures usually take the form of either small pinholes resulting in leakage or a weakening of the disk resulting in low bursting pressure. See Figure 46, 47, 48, 49, 50 and 51.

- a) Considerations for evaluating rupture disk corrosion include selecting the best material for the application. The cost of higher alloyed, corrosion resistant materials is often negligible relative to the cost of an unplanned maintenance shutdown.
- b) Linings and coatings generally only provide a degree of protection and rarely provide long term corrosion resistance.
- c) Published corrosion rates that are acceptable for piping and vessels may not be acceptable to rupture disks due to the thin materials and the small amount of material removal required to affect the bursting pressure.

- d) Crevice corrosion can occur in the scores of a rupture disk exposed to certain process fluids which can result in relatively rapid leakage or failure.



Figure 46 - Disk Subjected to Corrosion

7.2.3 Installation –

Issues under this category include the physical conditions of the installation as well as the installation technique.

- a) Liquid full systems are subject to pressure spikes. These pressure spikes are typically of a short duration and may not show up in process control instrumentation due to frequency of data sampling and transducer filtering. The rupture disk however can respond to pressure spikes that are less than 1 millisecond.
- b) Avoid locating the rupture disk in areas subject to high levels of flow induced turbulence.
- c) Discharge line draining. Discharge lines that can collect condensation or rain water are prone to disk damage from corrosion or freezing. See Figure 47.
- d) Follow the rupture disk manufacturer's instructions regarding required torque values. Under, over, or uneven torque can cause burst pressure and leakage issues.



Figure 47 - Dent Caused by Water Freezing in Discharge Line

7.3 Rupture disk holder

The rupture disk holder should be inspected for media build-up, corrosion, and damage. Clean with compatible solvent. Any mechanical cleaning of the seating area should be in accordance with the manufacturer's instructions.

COMMITTEE DRAFT



Figure 48 - Rupture Disk Holder Subjected to Excessive Corrosion

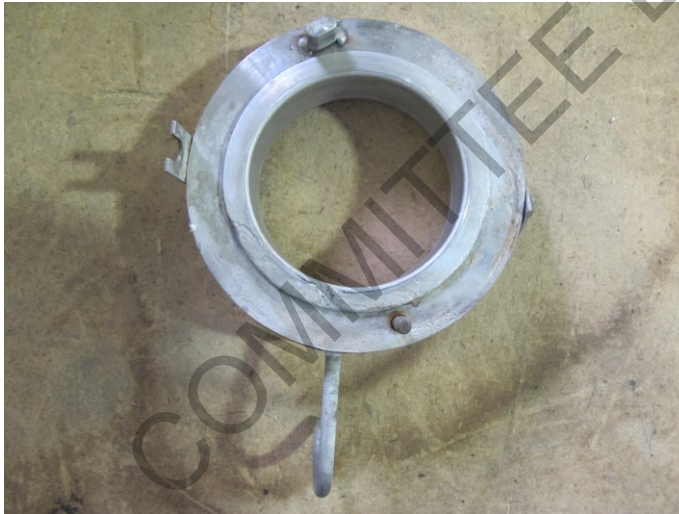

Figure 49 - Rupture Disk Holder Subjected to Corrosion



Figure 50 - Rupture Disk Holder Corrosion due to Leakage

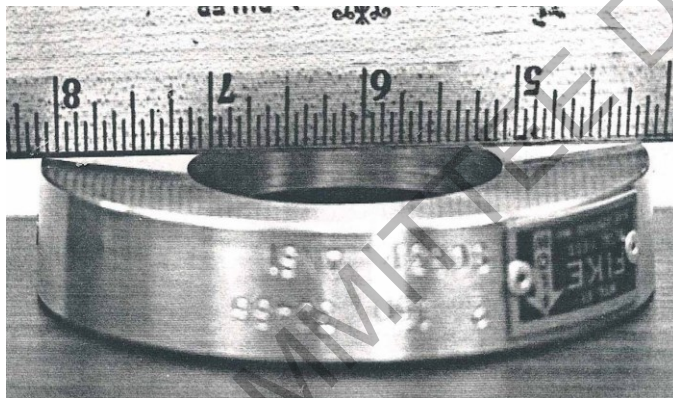

Figure 51 - Rupture Disk Holder Subjected to Over-torque

7.4 Inspection and Replacement of Rupture Disks

If a disk's manufacturer specifies a bolting torque procedure and the tightened bolts are loosened, the rupture disk should be replaced. Do not reinstall the disk once it has been removed from its holder, even though it has not been ruptured. When stresses are relieved by unbolting, the "set" taken by the disk during its original installation may prevent a tight seal and affect performance if reinstalled.

Rupture disks cannot be nondestructively tested and should be replaced on a regular schedule based on their application, the manufacturer's recommendations, consequences of nuisance releases and/or past experience. If a block valve is located ahead of the disk, the block valve should be locked or car sealed open during operation. If replacement of the disk is necessary, the block valve should be locked, car sealed, or tagged closed until disk installation has been accomplished. If, however, the risk of a rupture disk opening prematurely is low, and inlet and

outlet fouling is ~~appropriately addressed~~ ~~monitored (e.g., radiography)~~, the disk may be left in place for an extended interval.

Reverse-buckling rupture disks may be used to facilitate and allow on-stream testing of pressure-relief valves. For such testing, the section between the rupture disk and the pressure-relief valve is generally pressured with an inert gas testing medium. Since the rupture disk is exposed to pressure on its downstream side when using this procedure, the rupture disk should be inspected and replaced on a regular basis.

8 Pressure-relief Valve Visual On-stream Inspection

8.1 General

A full, visual on-stream inspection should ensure the following, but are not limited to:

- a) The correct relief device was installed.
- b) The company identification (such as a tag or stencil) provides means to establish the last test date and proper pressure setting for the equipment protected by the identified device.
- c) That information in 8.1 a) matches the equipment file records and that the established test interval has not been exceeded.
- d) No gags, blinds, closed valves, or piping obstructions would prevent the devices from functioning properly.
- e) Seals installed to protect the spring setting and ring pin setting have not been broken.
- f) The relief device does not leak. Pressure-relief valves that have opened in service frequently leak. Detection and correction of this leakage eliminates product loss and possible pollution and prevents fouling and subsequent sticking of the valve. If the valve is a bellows valve, the bellows vent should be checked for leakage.
- g) Bellows vents are open and clear, and the connected piping is routed to a safe location. These vents should always be referenced to atmospheric pressure.
- h) Upstream and downstream block valves are sealed or chained and locked in the proper position. Devices that ensure that a block valve is in its proper position include locking plastic bands, car seals, chains and padlocks, and special locking devices made especially for certain types of block valves. The field conditions should mirror the applicable piping and instrumentation diagrams (P&IDs).
- i) Vent stacks, outlet piping and small nipples are properly supported to avoid breakage or leakage. Inadequately supported or anchored nipples can be damaged during maintenance and by vibration.
- j) Valve body drains and vent stack drains are open.
- k) Stack covers are installed properly (i.e. bug vents and rain hats).
- l) The drain holes on PSV vent stacks are free of corrosion or are not plugged.
- m) Any lifting lever is operable and positioned properly.
- n) Any heat tracing, insulation, or purge that is critical to the proper operation of the relief system is intact and operating properly.
- o) A gauge installed as part of a combination of a rupture disk and a pressure-relief valve or a device for checking pressure between a pressure-relief valve and a block valve is

serviceable. Verify that there is no pressure buildup between the rupture disk and pressure-relief valve.

- p) Any rupture disk is properly oriented.
- q) Remote pressure sense lines for pilot operated valves are properly connected and open

8.2 Post Relief Event

Although the interval selected for on-stream inspection should vary with circumstances and experience, a visual inspection that includes a check for leakage, vibration and/or damage (e.g. loose fasteners, insulation, missing rain caps, deformation of components, etc.) should follow each operation of a pressure-relief device. Operating personnel assigned to the process unit may make these inspections provided that they are experienced to recognize any leakage or vibration damage. For PRD's in potentially fouling services, consideration should be given to servicing the PRD as soon as possible.

9 Inspection Frequency

9.1 General

The inspection of pressure relieving devices provides data that can be evaluated to determine a safe and economical frequency of scheduled inspections. This frequency varies widely with the various operating conditions and environments to which relief devices are subjected. Inspections may be less frequent when operation is satisfactory and more frequent when corrosion, fouling, operational upsets and leakage problems occur. Historical records reflecting periodic test results and service experiences for each relief device are valuable guides for establishing safe and economical inspection frequencies.

A definite time interval between inspections or tests should be established for every pressure relieving device on operating equipment. Depending on operating experiences, this interval may vary from one installation to another. The time interval should be sufficiently firm to ensure that the inspection or test is made, but it should also be flexible enough to permit revision as justified by past test records.

In API 510 and 570, the subsection on pressure relieving devices states the following for PRD inspection intervals: "Unless documented experience and/or a RBI assessment indicates that a longer interval is acceptable, test and inspection intervals for pressure-relieving devices in typical process services should not exceed:

- a) 5 years for typical process services, and
- b) 10 years for clean (non-fouling) and noncorrosive services."

9.2 Frequency of Shop Inspection/Overhaul

9.2.1 General

The interval between shop inspection/overhaul of pressure relieving devices should not exceed that necessary to maintain the device in satisfactory operating condition. The frequency of shop inspection/overhauls is normally determined by operating experience in the various services involved. Normally, the interval of a device in a corrosive and/or fouling service would be shorter than the interval required for the same device in a clean, nonfouling, noncorrosive, service. Likewise, more frequent inspection and testing may be needed for pressure-relief valves subject to vibration, pulsating loads, low differential between set and operating pressures, and other circumstances leading to valve leakage and potentially poor performance.

Where an inspection or test history extending over a long period of time reflects consistent "as-received" test results that coincide with the CDTP (see 6.2.9.1), where no change in service is to be made, and where no conflict in jurisdictional requirements exists, an increase in the test interval may be considered.

Conversely, if the "as-received pop test" results are erratic or vary significantly from the CDTP, the inspection interval should be decreased or suitable modifications to improve the performance should be made. If a valve fails to activate on the test block at 150 % or more of CDTP, it can be assumed that it would have failed to activate on the unit during an overpressure event.

Where corrosion, fouling, and other service conditions are not known and cannot be predicted with any degree of accuracy (as in new processes), the initial inspection should be accomplished as soon as practical after operations begin to establish a safe and suitable testing interval.

9.2.2 Manufacturer's Basis

Manufacturers of pressure relieving devices are sometimes able to assist the user in establishing inspection and test intervals, especially if their designs contain features and components that require special consideration. For example, it may be necessary to inspect or replace certain parts, such as nonmetallic diaphragms in pilot operated valves, at frequencies greater than those required for the parts of conventional pressure-relief valves. Rupture disks and bellows valves may also require special consideration. Manufacturers are familiar with the nature of the loading, stress levels, and operating limitations of their design and are able to suggest inspection intervals appropriate for their equipment.

9.2.3 Jurisdictional Basis

In some instances, the required frequency of inspection and testing of pressure relieving devices is established by regulatory bodies.

9.2.4 RBI Assessment Basis

RBI techniques to determine the initial and subsequent inspection intervals may be used which consider the probability and consequence of failure of pressure-relief devices to open on demand during emergency overpressure events. The risk-based techniques recognize the fact that there are many different overpressure events or scenarios and that some pressure-relief device applications are much more critical than others. The determination of risk should be based on the equipment being protected, the associated flammability, toxicity, corrosivity and fouling severity of the fluid services, as well as the overpressure event probability and potential overpressure as a result of failure to open upon demand. Other considerations, such as production losses, damage to surrounding equipment, the potential for personnel injury and any environmental impact should also be considered when evaluating the criticality of a pressure-relief device application.

The assessment should also consider the probability that a pressure-relief device will leak in service and the potential environmental and economic consequences associated with this leakage during normal operation.

As with conditioned-based inspection programs, risk-based programs make extensive use of knowledge gained from pressure-relief device operational experience and historical inspection servicing records. These are valuable inputs into the risk-based assessment models.

Risk assessments can range from the qualitative to the highly quantitative. Although quantitative assessments typically require more input, this is offset by the fact that these approaches result in a significant reduction in risk while better optimizing the inspection effort.

The requirements of API RP 580 should be incorporated into these assessments. API RP 581 is an API consensus document that provides details on a RBI methodology that has all of the key

elements defined in API RP 580. The potential benefits of a risk-based assessment include the following:

- a) systematic and well-developed technical methods and tools for evaluating pressure relieving devices which have a wide array of considerations,
- b) focus on risk management by addressing critical concerns to protect equipment overpressure,
- c) organized approach to improving pressure-relief device performance,
- d) incorporation of operational history and inspection servicing records,
- e) cost-effective risk mitigation task identification to address safety/health/environmental consequences and lessen economic loss.

9.2.5 Frequency of Visual On-stream Inspections

As noted in 8.1, visual on-stream inspections are intended to find problems with the maintenance and operating practices surrounding pressure relieving devices. The interval selected should vary with circumstances, based on the results of previous on-stream inspections. The maximum interval for visual on-stream inspections should be five years. Although not always a full visual on-stream inspection, some companies perform inspections for leakage and vibration damage each time a relief device operates.

After maintenance of the valve(s) are completed, a full visual on-stream inspection shall be performed before startup (section 8.1). This provides a critical check that the proper relief device is in the proper location, installed properly, and has the proper set pressure for the intended service.

9.3 Time of Inspection

9.3.1 Inspection on New Installations

All pressure-relief valves that depend on a spring adjustment for proper functioning should be inspected and tested before they are installed on process equipment (i.e. verify CDTP pressure and visual inspection as described in 6.2.9.1). This inspection is used to determine any damage or changes in factory adjustment due to shipping, confirm the set pressure, and initiate appropriate records. If the factory setting is done in a nearby shop, this additional testing may be unnecessary.

Pressure- and/or vacuum-vent valves on atmospheric storage tanks should also be internally inspected before the tank is hydrostatically tested or put into service. Pressure- and/or vacuum-vent valves on atmospheric storage tanks should also be inspected whenever the tank is taken out of service. Since these devices operate at near atmospheric conditions it is important that all valve or vent openings are not isolated or blocked in any way.

9.3.2 Routine Inspections

The ideal time to inspect pressure-relief devices is when the inspection least interferes with the process and maintenance manpower is readily available. These conditions may prevail during planned shutdowns. All relief devices not equipped with block valves should be inspected at this time if an inspection would otherwise become due before the next scheduled shutdown. The relief devices with block valves may be inspected at this time to minimize process interruptions and avoid the increased risk of inspecting equipment in operation.

9.3.3 Unscheduled Inspections

If a valve fails to open within the set pressure tolerance, it requires immediate attention. If it opens at the set pressure but fails to reseal properly, the urgency of inspection and repairs depends on

the type of leakage, its environmental and human impact, the amount of leakage, and the characteristics of the leaking substance such as whether it's toxic, flammable, or fouling. PRV's in fouling services that have lifted in service should be considered for servicing soon after the operation of the PRV.

9.3.4 Inspection after Extended Shutdowns

A pressure-relief valve left on a unit during an extended shutdown should be inspected and tested before the resumption of operations. This inspection is necessary to ensure that corrosion, fouling, tampering, or other conditions or acts that would impede the proper performance of the device have not occurred during the shutdown. When a change in operating conditions is to follow the shutdown, the inspection interval should be reviewed.

9.4 Inspection & Servicing Deferral

There are instances where the inspection and servicing scheduled date may need to be deferred. Such deferrals shall be in accordance with the applicable code of the protected asset(s) (e.g. API 510 Deferral of Inspection Due Dates or API 570 Inspection Deferral or Interval Revision). Additionally such deferrals should be treated as temporary extensions of PRV inspections/servicing due dates, and shall not be considered inspection/servicing interval revisions.

10 Records and Reports

10.1 General

A suitable system of keeping records and generating reports is essential to the effective administration and control of any pressure relieving device program in a process industry. The system should be as simple and clear as possible.

The primary objective for keeping records is to make available the information needed to ensure that the performance of pressure relieving devices meets the requirements of their various installations. Records may be considered as tools needed to implement the program, and reports may be considered as the means to distribute those tools to all the participants of the program so that they coordinate their work and effectively discharge their responsibilities. In most cases, reports may be retained in files and considered as permanent records.

10.2 The Need to Keep Records

For each pressure relieving device in service, a complete, permanent record should be kept. The record of each device should include its specification data, including sizing calculations and a continuously accumulating history of inspection and test results. The specification record provides the basic information needed to evaluate the adequacy of a device for a given installation or for a contemplated change in operating conditions, provides the correct dimensional and material information needed to minimize shop errors and expedite repairs, and provides design information that facilitates the purchase of a similar device and that is required to inventory spare parts. This information allows a pressure relieving device to be assembled, tested, and exchanged with an identical device on the unit to minimize the time the unit's equipment is unprotected during a scheduled inspection.

Historical records (service records) showing dates and results of inspections and tests are necessary for the follow-up or control phase of the pressure relieving device program. They enable periodic reviews to determine whether the planned test intervals for a device are being realized. They also provide performance data that helps evaluate the suitability of the device for its particular service, that can indicate problems in the device's design and materials, and that can even indicate a misapplication of the device. It is especially important that the records offer a practical and realistic basis for establishing and maintaining safe and economical inspection intervals for the device.

10.3 Responsibilities

The duties and responsibilities entailed by the various facets of an inspection and testing program for pressure relieving devices should be clearly defined to avoid confusion and be explicitly assigned to assure compliance. Some companies assign these duties and responsibilities to equipment inspectors or other equipment subject matter experts. Others have maintenance personnel in charge of an established PRV service program under the guidance of the engineering-inspection group.

This subsection is not designed to assign responsibilities to any individual. The following outline of duties is meant primarily to facilitate the understanding of how to use the sample record and report forms in the Annex B. These duties are typical of a well-designed, pressure relieving device program in the process industries.

10.3.1 The responsibilities of engineering and/or inspection may include but are not limited to the following:

- a) to furnish specifications and sizing calculations for relief devices and connected piping;
- b) to determine allowable pressure settings;
- c) to specify test intervals;
- d) to record service data;
- e) to prepare lists of devices due for inspection;
- f) to review inspection and overhaul results and identify and address issues;
- g) to review, approve, and/or purchase replacement valves or spare parts;
- h) to ensure piping and instrumentation diagrams (P&IDs) match the field installation and equipment protected.
- i) to conduct visual on-stream inspections at the requisite interval
- j) to conduct profile radiograph of inlet and outlet piping at specified intervals looking for corrosion and fouling
- k) to ensure that new or modified equipment is reviewed for adequate over-pressure protection.

10.3.2 The responsibilities of Operations and/or Inspection may include but are not limited to the following:

- a) to initiate work requests,
- b) to see that devices are reinstalled in their proper location,
- c) to prepare in-service reports,
- d) to check for leaking valves and rupture disks,
- e) to ensure that the correct block valves (if any) are locked or sealed open or closed as required,
- f) to check vents and drains for operability,
- g) to check the upstream and downstream piping for blockage and to perform condition assessment inspections.

10.3.3 The responsibilities of maintenance may include but are not limited to the following:

- a) to perform the mechanical work required to repair, test, reinstall, and attach identification tags to the devices;
- b) to maintain specification records to facilitate repairs;
- c) to furnish test reports;
- d) to initiate purchase orders for spare parts.

10.4 Sample Record and Report System

The precise recording and reporting format in a pressure relieving device program is a matter of individual company choice. The forms in Annex B are samples of records and reports. Much of the report writing, recordkeeping, inspection, and test scheduling handled by the reports and records should be managed with an electronic database system.

COMMITTEE DRAFT

Annex A

(informative)

Pressure-relief valve Testing

A.1 Need and Function of Test Block

After a pressure-relief valve is removed from service, it is usually taken to the shop for inspection and repair. An important phase of maintenance is testing to determine the set pressure and tightness of the valve "as-received" and after its overhaul. The testing is usually performed on a test block with facilities for applying pressure to a valve and indicating the pressure applied. Most test blocks have facilities for testing with either air or water to simulate, as closely as possible; the media handled by safety and relief valves, respectively. Bottled nitrogen may be used instead, especially for high-pressure valves. See ASME *BPVC* Section I, Section IV, and Section VIII, for requirements on setting safety valves in steam service.

The test block and its supporting facilities are necessary for the maintenance of pressure-relief valves. It is practically impossible to make accurate adjustments on these devices without some method of measuring their performance. The shop test block, unfortunately, does not duplicate field conditions exactly. Thus, the amount of liquid or gas that it can discharge is limited, and it is not generally practical to measure relieving capacity or blowdown. Also, test stands with insufficient surge volume may fail to cause a distinct opening pressure, and an inaccurate set pressure may result. However, if properly functioning, the shop test block gives good indications of the pressure at which the valve will open and its tightness.

For safety, the valve discharge nozzle shall be positioned to prevent exposure of personnel to a sudden blast of air, water, or other projectiles from the valve. Ear protection may also be required for personnel working in the test area. Do not attempt to test relief devices at pressures above that for which the test block is designed.

If a pressure-relief valve is dirty and cycling the valve would damage its seats, the "as-received" pop pressure test may be waived. If the test is waived, reduction of the valve's test interval should be considered.

A.2 Testing with Air

Most test blocks are designed to test pressure-relief valves with air because it is a nontoxic and readily available medium. Air is compressible and causes valves to relieve with a distinct opening and closely approximates operating conditions for pressure-relief valves in vapor and gas services. The air test is generally used to test safety, and safety relief valves for set pressure and seat tightness.

The arrangement to detect leakage during the air test depends on the construction of the valve. Blinding of the valve discharge is usually required. Leakage may be detected qualitatively by placing a thin membrane, such as a wet paper towel, over the outlet and noting any bulging. This is not a rigid test and is not intended to be used as a commercial standard tightness test. A quantitative measurement may be made by trapping the leakage and conducting it through a tube submerged in water. Figure A.1 shows the standard equipment used to determine leakage rates in API 527. Leaks can also be detected with ultrasonic sound detection equipment.

A.3 Testing with Water

Test blocks may include facilities that test relief valves with a liquid test medium such as water. Water is nontoxic and inexpensive and may allow a close simulation of operating conditions. Because

very small water leaks are not readily detected, a water test is usually limited to measuring the set pressure.

A.4 Description of Test Block

The test block is the assembly of equipment required to test pressure-relief valves for set pressure and tightness. It is used often and should be readily available on short notice. Test block designs vary widely and are even offered as packaged equipment by some manufacturers. The schematic arrangement in Figure A.1 illustrates the essential elements of and instructions for a test block that uses air as the testing medium. Where air pressure is unavailable, water systems may instead be used to test relief valves if acceptable to the local authority or jurisdiction.

The air-system test block includes a compressor or other source of high-pressure air, a supply reservoir, a test drum or surge tank large enough to accumulate enough air to cause the valves to open sharply at the set pressure, and the piping, pressure gauges, valves, and other instrumentation necessary to control the tests. The water-system test block usually includes a positive displacement pump that with a reasonably steady flow of water develops high pressures and the piping, valves, and other instrumentation necessary to control the tests. Some test blocks use a combination gas over water arrangement in which the gas provides the source of pressure.

Both the air-system test block and the water-system test block use a manifold. The wide range of flange sizes on a manifold allows it to test many different valves. To cover the wide range of pressures usually required to test pressure-relief valves, several precision-calibrated pressure gauges are connected with the manifold. These pressure gauges should be routinely calibrated, and a progressive calibration record should be maintained.

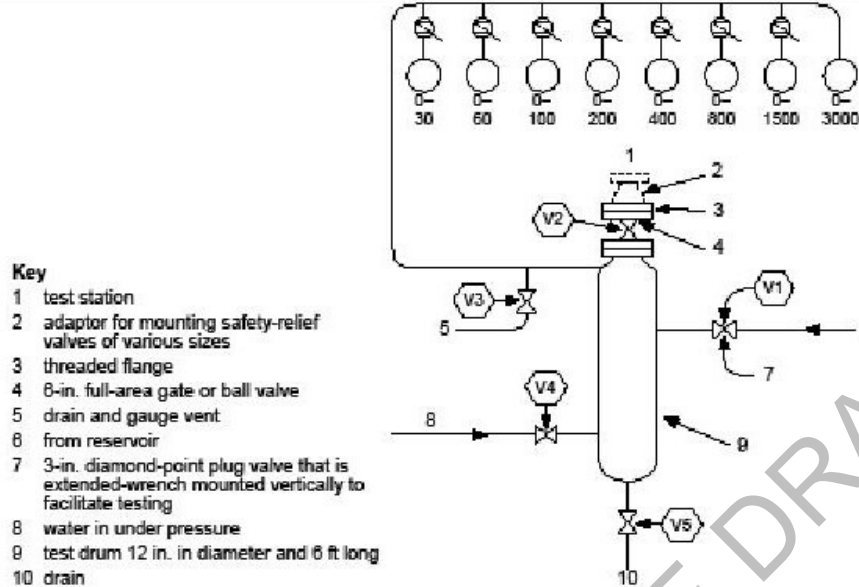

Figure A.1 - Typical Safety Valve and Relief Valve Test Block Using Air as a Test

CONSTRUCTION NOTES

- 1) This layout uses the available air supply at the highest pressure possible. If required, the pressure can be raised further by inserting water that is under pressure into the test drum until the desired pressure is reached.
- 2) A single test drum is shown. Duplicate stations for flanged valves can be added if desired. Another duplicate station with a smaller test drum is sometimes desirable for testing small valves with screwed connections.
- 3) Flanged valves are to be secured to test stations by bolting, clamping, or use of a pneumatic clamping device.
- 4) Line from reservoir to test drum is to be designed for minimum pressure drop to allow reservoir volume to hold up test drum pressure when needed.
- 5) Test drum pressure and piping are to be made of oxidation-resistant materials.

OPERATION NOTES

- 1) When test station is not in use, Valves V1, V2, V4, and V5 should be closed. Valve V3 should be opened to prevent possible buildup pressure in the test drum if Valve V1 should leak.
- 2) Before testing the first valve, the test drum should be blown to remove any accumulation of dust or sediment that might blow through the safety relief valve and damage the seats. To blow the drum, close Valve V3, open Valve V2, and release air through the drum by opening and closing Valve V1.
- 3) Close Valve V2.
- 4) Secure safety relief valve to test station.
- 5) Open Valve V2.
- 6) If safety-valve set pressure is lower than available air pressure, slowly increase pressure through Valve V1 until safety relief valve actuates. Then close Valve V1. If safety-valve set pressure is higher than available air pressure, open Valve V1 and fill test drum with maximum air pressure available. Then close Valve V1. Open Valve V4 and increase pressure by inserting water that is under pressure until safety relief valve opens. Then close Valve V4 and drain water from drum by opening and closing Valve V5.
- 7) If necessary, adjust valve spring so that safety relief valve opens at the required set pressure.
- 8) Vent test drum to 90 % of the set pressure.
- 9) Test safety relief valve for leakage.
- 10) After satisfactory test, close Valve V2.
- 11) Remove safety relief valve from test rack. Loosen bolts or clamps slowly to allow pressure in adaptor and valve nozzle to escape.
- 12) Vent test drum through V3 to approximately 75 % of the set pressure of the next valve to be tested. Repeat Items 4) through 11).
- 13) If another valve is not to be tested immediately, leave test station as specified in Item 1).

Annex B (informative)

Sample Record and Report Forms

The specification record for a pressure relieving device shown in Figure B.1 is a typical permanent record for specifying a pressure-relief valve. This record holds the basic information needed to properly repair or replace the valve.

The historical record for a pressure relieving device shown in Figure B.2 is a typical permanent service record that holds the dates and results of periodic inspections and tests. The information recorded will form a basis for determining test intervals and design changes.

In the record and report program illustrated in Figure B.3, the engineering-inspection group maintains the records and periodically informs the operations group responsible for operating the pressure-relief valves of the due dates of any work to be done. A report such as that shown in Figure B.3 (with sample data) is a simple and effective means for initiating inspection, testing and repair work. Its return to the engineering-inspection group indicates that the operations group responsible for operating the pressure-relief valves has taken action. The report should list all the pressure relieving devices at a given unit to help minimize oversights and clerical work.

When a valve is sent to the shop for inspection, it is inspected and tested by the maintenance group in the "as-received" condition. A report such as the testing report for a pressure relieving device shown in Figure B.4 is filled out to document the results of this inspection and testing.

Inspection and testing of a device may lead to its setting and repair by the maintenance group. Orders and records such as the condition, repair, and setting record for a pressure relieving device and the setting record and repair order for pressure relieving devices shown in Figure B.5 should be filled out as appropriate.

At the shop, the valve may have a part replaced with a spare part by the maintenance group. In this case, documentation is prepared indicating the replacement as well as other basic information on the condition, repair, and setting record for a pressure relieving device form.

After a pressure-relief valve has been returned to the process unit and installed by the operations group, the authority in the operations group responsible for writing the valve work orders should prepare a report such as the in-service report for a pressure relieving device. This report is filled out to certify that the valve has been reinstalled in its proper location. The report should be sent to the engineering-inspection group. It serves as an independent check on earlier steps and as the final expected report on this particular inspection of the pressure relieving device.³

³ The following samples are merely examples for illustration purposes only. (Each company should develop its own approach.)

SPECIFICATION RECORD FOR A PRESSURE-RELIEVING DEVICE

Device No.	Unit	Location	Set Pressure	Test Interval
Make _____ Style _____ Remarks _____ Body and bonnet material _____ Nozzle and disk material _____ Trim material _____ Spring material: <input type="radio"/> Carbon steel <input type="radio"/> Alloy Spring no. _____ Flange sizes Inlet _____ Outlet _____ Orifice _____ Backpressure _____ Spring set pressure _____ Relieving pressure _____ Normal operating temperature _____ Maintenance engineer's phone no. _____				

Figure B.1 - Sample Form for Recording Pressure relieving Device Specifications

INSPECTION AND REPAIR WORK ORDER AND REPORT FOR PRESSURE-RELIEVING DEVICES (WITH SAMPLE DATA)

To _____
 Unit _____
 Period _____

All pressure-relieving devices installed on the unit are shown on this list. Those due for testing before expiration of the above period are indicated in the "Due for Test" column by an "X." Please prepare a work request to cover the inspection and repair of the devices indicated and return this work order and report to the engineering-inspection group by _____.

Due for Test	Device No.	Location	Work Requested	Work Request No.
X	FC-100	C-2A compressor discharge		
	FC-101	C-2B compressor discharge		
	FC-102	C-2C compressor discharge		
	FC-103	E-1 tower overhead line		
X	FC-104	E-1 tower bottoms line		
	FC-105	D-25 caustic drum		
	FC-106	J-10A blower discharge		
	FC-107	Rerun tower E-5		
	FC-108	J-63 pump-out		
	FC-109	E-20 exchanger (tube side)		
	FC-110	F-21 drum		
	FC-111	D-37 air drum		
	FC-112	E-2 tower		
	FC-113	E-3 tower		
	FC-114	E-4 tower		
	FC-115	F-1 drum		
	FC-116	E-18 exchanger (tube side)		
Date issued _____ By _____				

Figure B.3 - Sample Inspection and Repair Work Order Form

TESTING REPORT FOR A PRESSURE-RELIEVING DEVICE

Fill in this report for each device tested and send this report to the quality-assurance group.

Date tested _____	Type _____
Device no. _____	Make _____
Unit _____	Style _____
Location _____	Material _____
Size _____	Special material _____
Inlet _____	Body _____
Orifice _____	Trim _____
Outlet _____	

Fill in blanks below on one side only.	
From unit	From spare stock or check of new device
Date last bench tested _____	Set pressure _____
Popped at _____	Check pressure _____
Set pressure _____	
Check (dirty pop) pressure _____	
If set pressure changed, new set pressure _____	
Test used	
Standard _____	
Dry seal _____	
Disposition	
To unit _____	
To spare _____	
To junk _____	
Condition	
Leaking _____	
Stuck _____	
Fouled _____	
Corroded _____	
Tested by _____	

Figure B.4 - Sample Testing Report

IN-SERVICE REPORT FOR A PRESSURE-RELIEVING DEVICE

Upon completion of this report, put it in the special envelope provided and send it to the engineering-inspection group.

Device no. _____	Unit _____
Date tested _____	Location _____
Date installed _____	_____

Figure B.5 - Sample In-service Report

COMMITTEE DRAFT

Bibliography

- [1] API Recommended Practice 581, *Risk-Based Inspection Technology*

COMMITTEE DRAFT