

IWAKI Metering Pump

LK-F Series

Instruction Manual

 Read this manual before use of product

Thank you for selecting the Iwaki Mechanical-driven Diaphragm Type Metering Pump model LK-F. This instruction manual has been prepared to ensure correct and safe handling of the pump. Please read this manual carefully and thoroughly prior to operating the pump. Pay special attention to the "Safety Instruction to Prevent Personal Injuries," "Warning," and "Caution" messages included in this manual.

This instruction manual should be kept by each end user and within reach of the actual operator, for quick reference when needed.

Contents

IMPORTANT INSTRUCTIONS	1
Safety Instructions to Prevent Personal Injuries	
OUTLINE OF PRODUCT	4
1. Before Using Pump	5
2. Operating Principle	5
3. Identification Codes	6
4. Specifications and Outer Dimensions	7
5. Description on Main Unit and Level	20
PUMP OPERATION	21
1. Handling Instructions	22
2. Installation	24
3. Piping	25
4. Wiring	27
5. Operation Step	27
MAINTENANCE	31
1. Causes of Trouble and Troubleshooting ..	32
2. Maintenance and Inspection	34
3. Consumable Parts	35
4. Disassembly and Assembly	36

Please contact the Iwaki sales office or Iwaki dealer for any inquiries or questions regarding this product.



IMPORTANT INSTRUCTIONS

Important notes and statements for safe operation, preventing physical injury, and property damage, are included on the body of the product and in the attached instruction manual.



Always Observe These Safety Instructions!

Safety Instruction to Prevent Personal Injuries

In this manual, the following symbols and signs are used to clearly indicate safety instructions.

 Warning	Nonobservance or misapplication of the contents of the "Warning" section could lead to a serious accident, including death or injury.
 Caution	Nonobservance or misapplication of the contents of the "Caution" section could lead to serious physical injury to the user or serious damage to the product.

Types of Symbols

-  Indicates that "Warning" or "Caution" must be exercised. Inside this triangle, a concrete and practical image provided as a warning or caution message is depicted.
-  Indicates a prohibited action or procedure. Inside or near this circle, a concrete and practical image of the activity to be avoided is depicted.
-  Indicates an important action or procedure which must be performed or carried out without fail. Failure to follow the instructions herein can lead to malfunction or damage to the pump.



Warning

(Always read and observe the following instructions to prevent personal injuries.)

- **Damaged or deteriorated tools are very dangerous.** Use qualified and suitable tools only.
- **Use of protectors:** When disassembling, assembling, and conducting maintenance or when handling a dangerous type of liquid or a liquid of unknown property, be sure to wear safety gloves, a helmet, and protective shoes. In addition, when handling wet-end parts, always wear protective goggles, masks, etc.
- **To prevent death or injury from a falling pump,** make sure the rope or chain used for lifting the pump is not accidentally cut or disconnected during installation. Make sure the rope or the chain used to lift the pump has sufficient strength in relation to the pump load. Also, be sure not to stand underneath a lifted or suspended pump.
- **Always turn off the power supply prior to servicing the pump.** Make special provisions so that no other operator mistakenly turns on the power supply while someone is working on the pump. In a noisy or poor visibility environment, display a sign near the power supply switch to notify others that someone is "WORKING" on the pump. Power supply mistakenly turned on during maintenance may lead to personal injury. Each operator must be especially careful of power supply operation.
- **To ensure greater safety, check and make sure that there is no one near the pump when switching on the power supply.** The pump is not equipped with an ON/OFF switch. Connecting the power cable or power plug supplies the power to the pump and starts the operation.
- **Run the pump at the specified power supply voltage on the nameplate only.** Otherwise, fire or electric shock may result.
- **If the pump operation is stopped due to a power failure or closure of discharge line,** turn off the power switch at once. After normal conditions return, turn the switch on again.
- **Do not use the pump for anything that it is not designed to do.** User's failure to observe this instruction exempts Iwaki from any responsibility for personal injury or damage to the equipment or facility caused by the pump's misuse.
- **When handling a toxic or odorant liquid,** ventilate the working area well. In addition, the operator must wear protector gear (such as a safety mask, safety goggles, and protective gloves).
- **Do not allow toxic substances such as lubricants, solvents, or similar substances to flow into the local sewage system or river systems.** Do not drain hazardous liquids such as chemical solutions discharged out of the pump directly onto the ground. Instead, drain such liquids into some kind of container. Observe the laws and regulations related to the application, handling, and processing of hazardous substances.



Caution

(Always read and observe the following instructions to prevent personal injuries.)

- *Wear gloves when working with rope or chain. Working with bare hands may result in serious injury, since fingers are likely to be caught between the pump and the rope or chain when the rope or chain is under strong tension.*
- *The pump is not designed to be used under water. Operate the pump on in-line mode only.*
- *Provide a safety valve on the discharge line.*
- *Do not close any discharge or suction valve while in operation.*

OUTLINE OF PRODUCT

<i>1. Before Using Pump.....</i>	<i>5</i>
<i>2. Operating Principle</i>	<i>5</i>
<i>3. Identification Codes</i>	<i>6</i>
<i>4. Specifications and Outer Dimensions.....</i>	<i>7</i>
<i>5. Description on Main Unit and Lavel...</i>	<i>20</i>

1. Before Using Pump

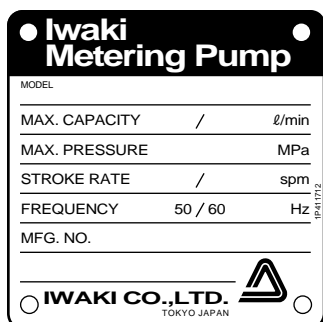

After unpacking, check the following points to confirm that the delivered product its accompanying parts and elements are exactly what you ordered.

When lifting the pump please follow the procedure mentioned "2. Installation" of "pump operation".

- [1] Do the model and frequency indicated on the nameplate conform to your order?
- [2] Has the pump unit or any part of it been damaged or bolts and nuts been loosened during delivery?

If you find anything wrong, please refer to the dealer you placed your order with.

2. Operating Principle

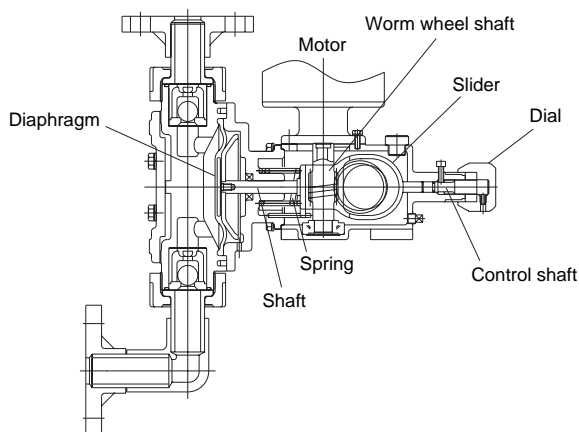

The rotation of the motor is reduced by means of the worm and wheel. The rotary motion is changed to a reciprocating motion by the spring-back mechanism (including the worm wheel shaft, slider, spring, etc.). The reciprocating motion is transmitted to the diaphragm directly connected with the shaft, changing the volume inside the pump chamber. Thus, variation of the volume inside the pump chamber and the functioning of the valves in the pump head produce pump operation.

For adjusting the stroke length, the adjusting dial fixed on the control shaft is rotated to change the return of the slider.

3. Identification Codes

Example:

LK-F 31 VC H - 02 F E S ① ② ③ ④ ⑤ ⑥ ⑦ ⑧	
① Series	LK-F Type Series
② Type symbol	Refer to “4. Specifications and Outer Dimensions” on page7.
③ Material symbol	Refer to the material table on page7. (ex. VC, VH, VS, S6,)
④ Connection	None: Flange (JIS) U : Union H : Hose
⑤ Motor output	02: 0.25kW
⑥ Special motor	F: Inverter motor (Note) General-purpose motors have no symbol.
⑦ Servo unit	E: with electric servo unit
⑧ Special symbol	S: Special specification other than standard

■ Standard Material

Material symbol		VC	VH	VS	S6	
part	Pump head	PVC	PVC	PVC	SUS316	
	Valve vall	CE	HC	HC/SUS304	HC	
	Valve seat	Type 11 to 32	FKM	EPDM	SUS304	SUS316
		Type 45 to 57	PVC	PVC	SUS304	SUS316
	O ring	FKM	EPDM	EPDM	-	
	Valve gasket	PTFE			PTFE	
Diaphragm	PTFE+EPDM					

CE:Alumina ceramics HC:Hastelloy C267

(Note) For the actual names of the parts, refer to a paragraph which deals with the parts.

4. Specifications and Outer Dimensions

Model	Capacity L/min		Allowable pressure limit MPa		Stroke speed spm		Connection			
	50Hz	60Hz	PVC *	SUS *	50Hz	60Hz	Flange (Nominal dia)		Union	Hose
							PVC *	SUS *1	PVC *	PVC
LK-F 11	0.020	0.024	1.0	1.5	48	58	JIS10K 15A (VH, VC, VS) JIS10K 25A (LK-47VS)	JIS16K 15A	VP16 VP25 (LK-47VS)	I.D.4mm O.D.9mm
21	0.050	0.060	1.0	1.5	48	58				
22	0.10	0.12	1.0	1.5	96	116				
31	0.25	0.30	1.0	1.5	48	58				
32	0.50	0.60	1.0	1.5	96	116				
45	0.85	1.0	1.0	1.5	48	58				
47	1.7	2.0	0.8	0.8	96	116				
55	2.8	3.3	0.5	0.5	48	58	φ 25 JIS10K	—	—	
57	6.0	7.2	0.3	0.3	96	116				

* PVC refers to the material symbols VC, VH, or VS while SUS refers to the material symbol S6.

■ Outer dimensions

LK-F11, 21, 22, 31, 32, 45, 47, 55, 57, VC, VH, VS

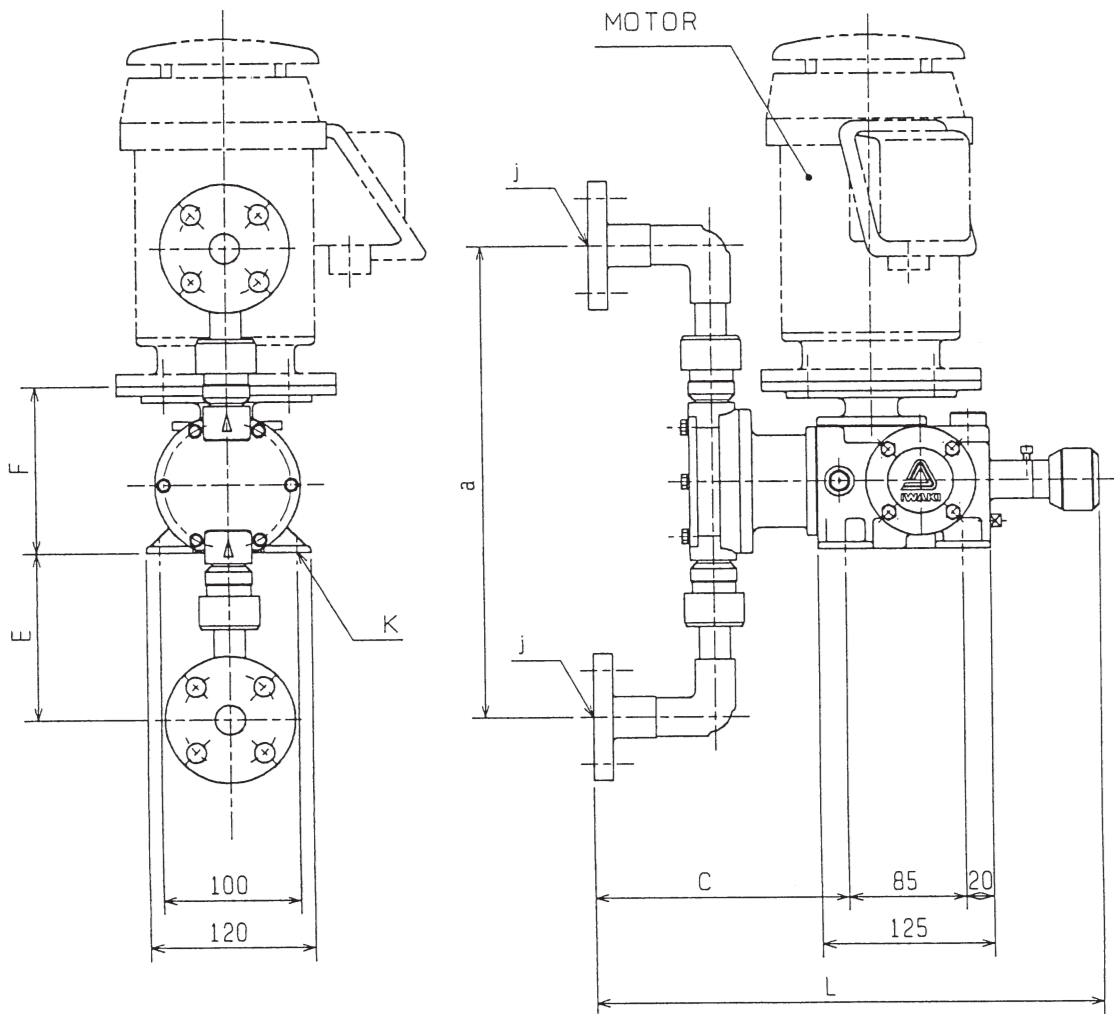

Model	L	a	C	E	F	j	K
LK-F11, VC, VH, VS	363	272	184	86	123	15	4 - ϕ 9
LK-F21, 22, VC, VH, VS	363	290	184	95	123	15	4 - ϕ 9
LK-F31, 32, VC, VH, VS	366	350	186	125	123	15	4 - ϕ 9
LK-F45, 47, VC, VH, VS	370	370	188	135	123	15	4 - ϕ 9
LK-F55, 57, VC, VH, VS	395	370	211	125	123	25	4 - ϕ 9
LK-F47VS	378	208	196	104	123	25	4 - ϕ 9

■ Outer dimensions

LK-F11, 21, 22, 31, 32, 45, 47, VCH, VHH, VSH

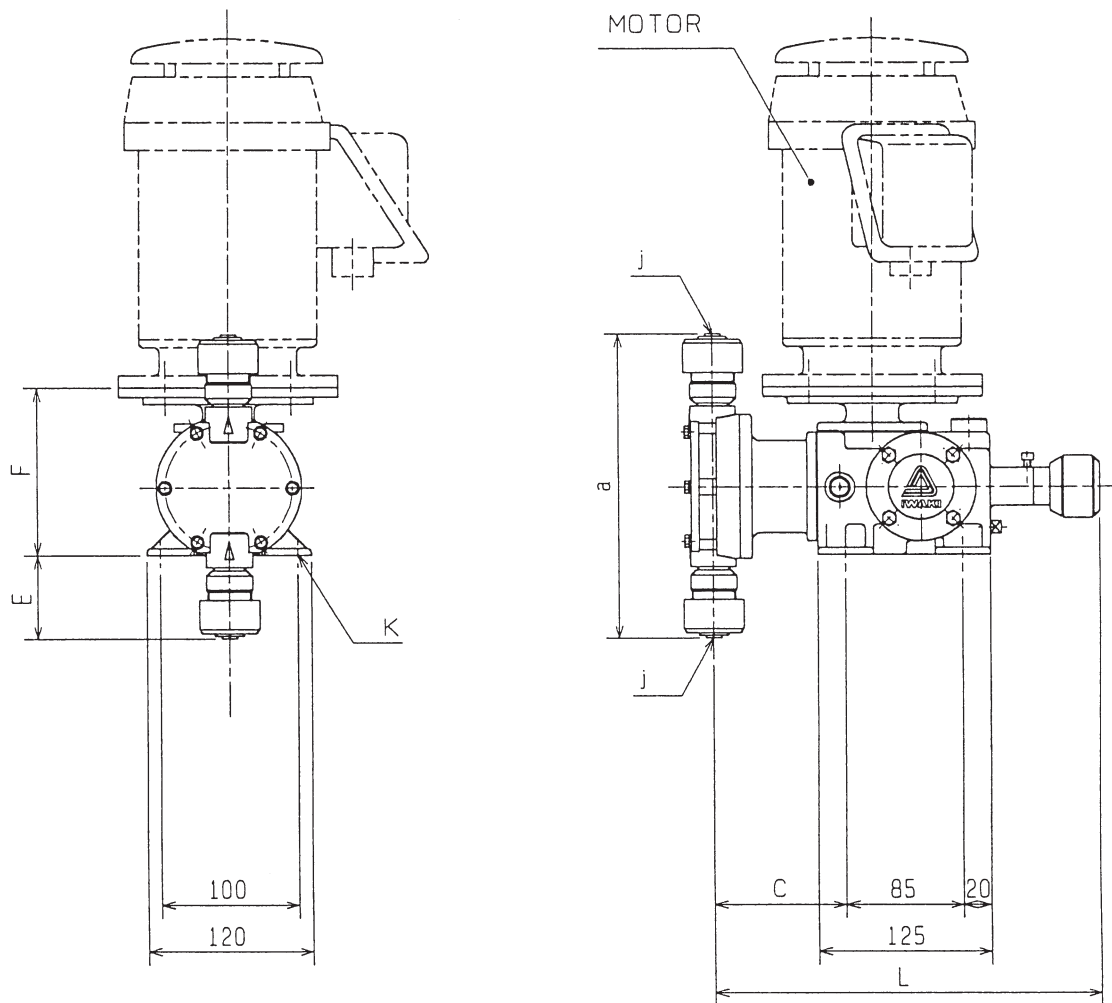

Model	L	a	C	E	F	j	K
LK-F11, VC, VH, VS	275	146	95	23	123	$\phi 4 \times \phi 9$	4 - $\phi 9$
LK-F21, 22, VC, VH, VS	275	164	95	32	123	$\phi 4 \times \phi 9$	4 - $\phi 9$
LK-F31, 32, VC, VH, VS	277	224	97	62	123	$\phi 12 \times \phi 18$	4 - $\phi 9$
LK-F45, 47, VC, VH, VS	281	243	99	72	123	$\phi 12 \times \phi 18$	4 - $\phi 9$

■ Outer dimensions

LK-F11, 21, 22, 31, 32, 45, 47, 55, 57 VCU, VHU, VSU

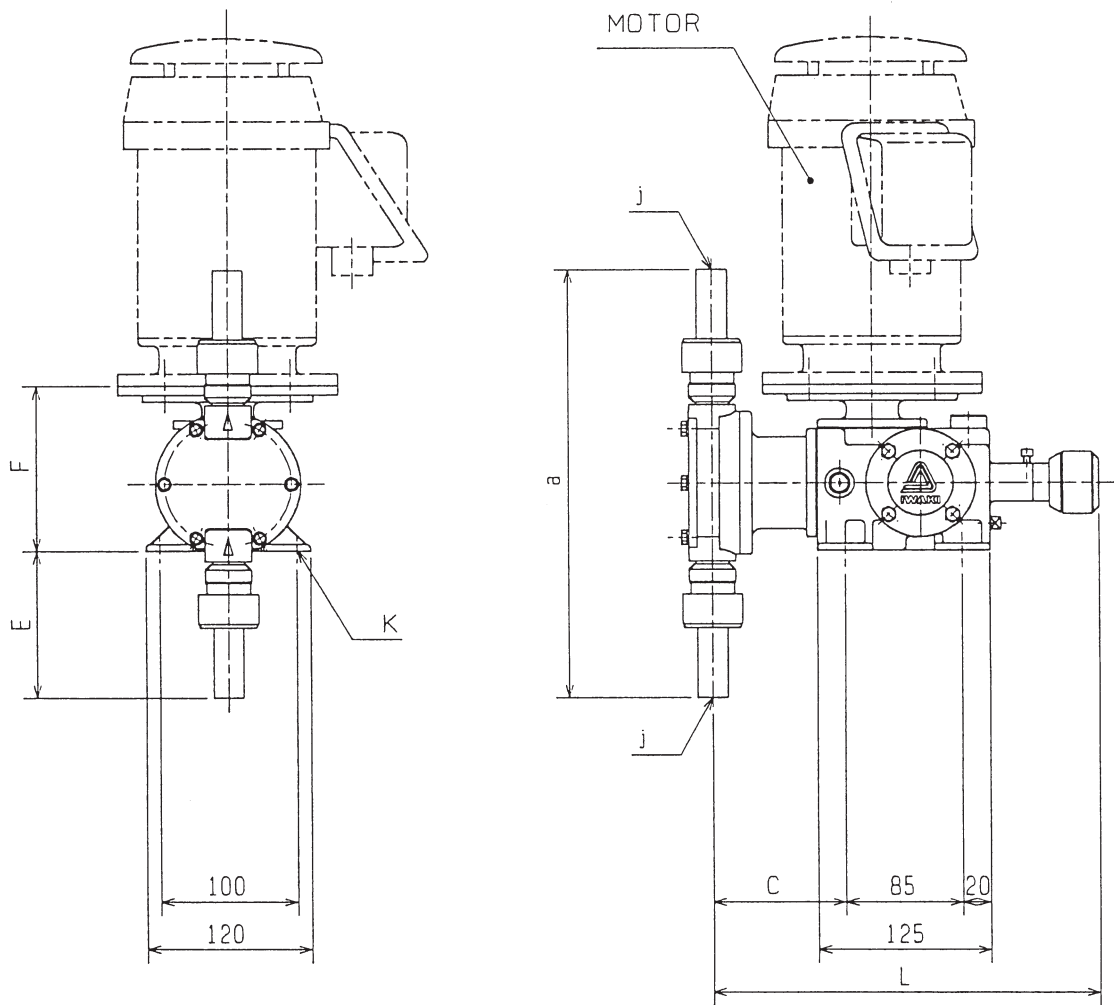

Model	L	a	C	E	F	j	K
LK-F11, VCU, VHU, VSU	275	244	95	70	123	16	4 - ϕ 9
LK-F21, 22, VCU, VHU, VSU	275	262	95	79	123	16	4 - ϕ 9
LK-F31, 32, VCU, VHU, VSU	277	318	97	109	123	16	4 - ϕ 9
LK-F45, 47, VCU, VHU, VSU	281	337	99	119	123	16	4 - ϕ 9
LK-F55, 57, VCU, VHU, VSU	298	314	114	125	123	25	4 - ϕ 9

■ Outer dimensions

LK-F11, 21, 22, 31, 32, 45, 47, 55, 57, S6

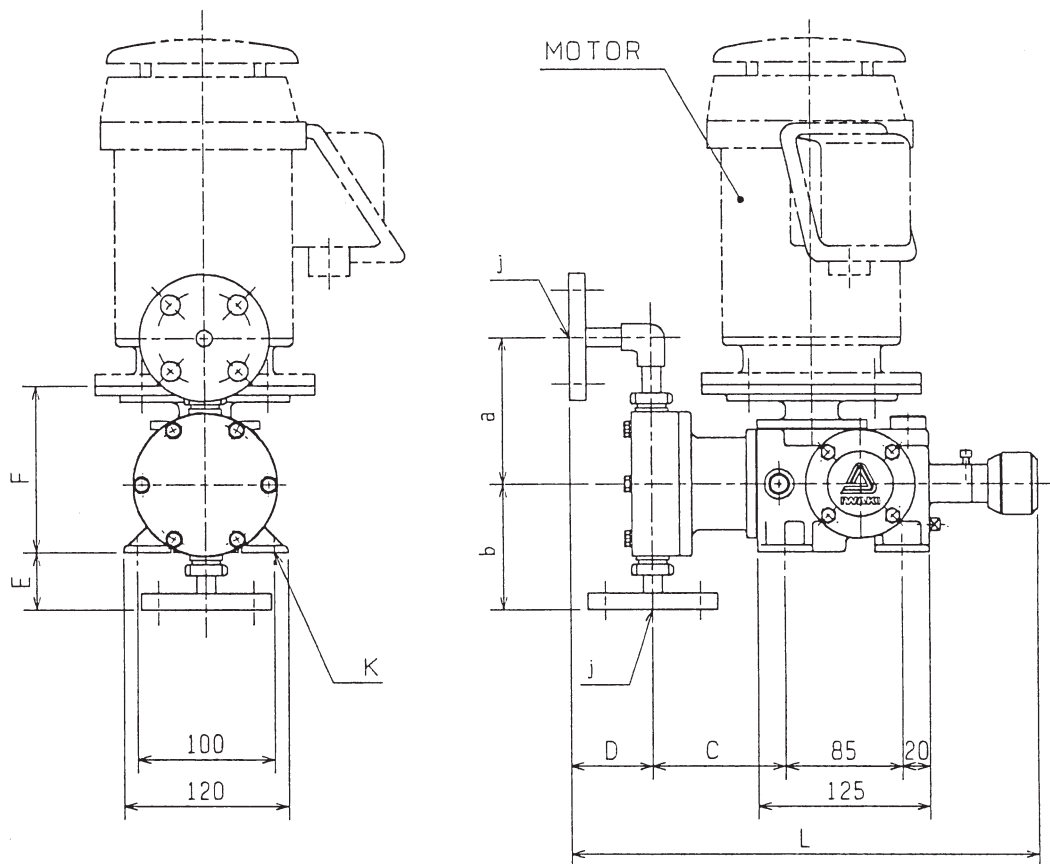

Model	L	a	b	C	D	E	F	j	K
LK-F11 S6	332	87	70	92	60	20	123	15	4 - ϕ 9
LK-F21, 22 S6	332	91	75	92	60	25	123	15	4 - ϕ 9
LK-F31, 32 S6	337	109	92	97	60	42	123	15	4 - ϕ 9
LK-F45, 47 S6	343	140	130	101	60	80	123	15	4 - ϕ 9
LK-F55, 57 S6	399	208	160	111	104	110	123	25	4 - ϕ 9

5. Names of Parts

■ LK-F11, 21, 22, 31, 32 VC, VH, VS

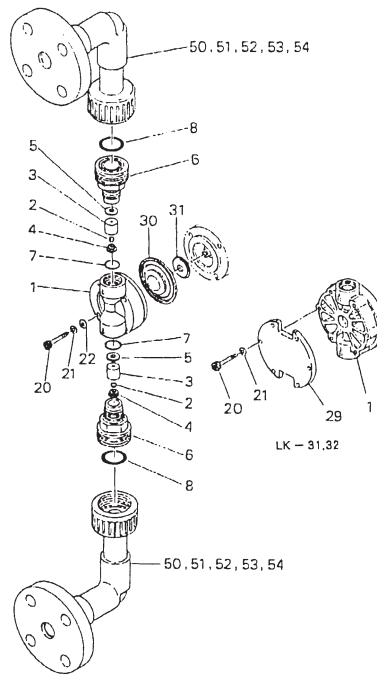

No.	Parts name	Q'ty	Material		
			VC	VH	VS
1	Pump head	1	PVC	PVC	PVC
2	Valve (ball check)	2	ALUMINA CERAMIC	HASTELLOY C	HASTELLOY C
3	Valve guide	2	PVC	PVC	PVC
4	Valve seat	2	FKM	EPDM	SUS304
5	Valve gasket	2	PTFE	PTFE	PTFE
6	Adapter	2	PVC	PVC	PVC
7	O-ring	2	FKM	EPDM	EPDM
8	O-ring	2	FKM	EPDM	EPDM

No.	Parts name	Q'ty	Material	Remarks		
				LK-F11	LK-F21, 22	LK-F31, 32
20	Hex. socket bolt	-	STNLS STL	M4 × 35 4PCS		
20	Hex. head bolt	-	STNLS STL		M5 × 30 4PCS	M5 × 45 6PCS
21	Spring washer	-	〃	4PCS	4PCS	6PCS
22	Plate washer	-	〃	4PCS	4PCS	6PCS
29	Reinforcing plate	-	Steel	—	—	1PC
30	Diaphragm	1	PTFE+EPDM			
31	Retainer	1	SUS304			
50	Nut*	2	PVC			
51	Union (socket)*	2	〃			
52	Elbow*	2	〃			
53	Pipe*	2	〃			
54	Flange*	2	〃			

Note: The parts asterisked (*) are supplied as the flange unit.

■ LK-F11, 21, 22, 31, 32 VHH, VCH, VSH

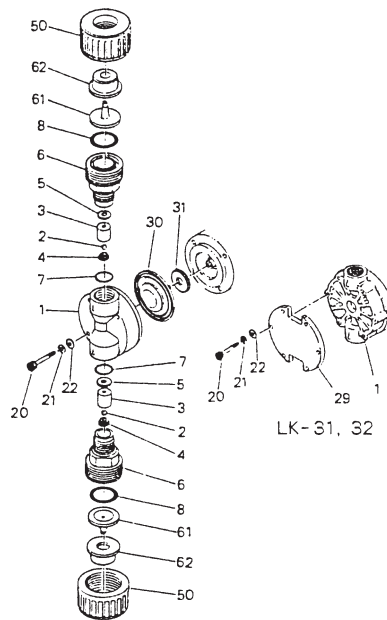

No.	Parts name	Q'ty	Material		
			VC	VH	VS
1	Pump head	1	PVC	PVC	PVC
2	Valve (ball check)	2	ALUMINA CERAMIC	HASTELLOY C	HASTELLOY C
3	Valve guide	2	PVC	PVC	PVC
4	Valve seat	2	FKM	EPDM	SUS304
5	Valve gasket	2	PTFE	PTFE	PTFE
6	Adapter	2	PVC	PVC	PVC
7	O-ring	2	FKM	EPDM	EPDM
8	O-ring	2	FKM	EPDM	EPDM

No.	Parts name	Q'ty	Material	Remarks		
				LK-F11	LK-F21, 22	LK-F31, 32
20	Hex. socket bolt	-	STNLS STL	M4 × 35 4PCS		
20	Hex. head bolt	-	STNLS STL		M5 × 30 4PCS	M5 × 45 6PCS
21	Spring washer	-	∕	4PCS	4PCS	6PCS
22	Plate washer	-	∕	4PCS	4PCS	6PCS
29	Reinforcing plate	-	Steel	—	—	1PC
30	Diaphragm	1	PTFE+EPDM			
31	Retainer	1	SUS304			
50	Nut*	2	PVC			
61	Tube insert	2	∕			
62	Ferrule	2	Steel			

Note: The parts asterisked (*) are supplied as a unit.

■ LK-F11, 21, 22, 31, 32 VHU, VCU, VSU

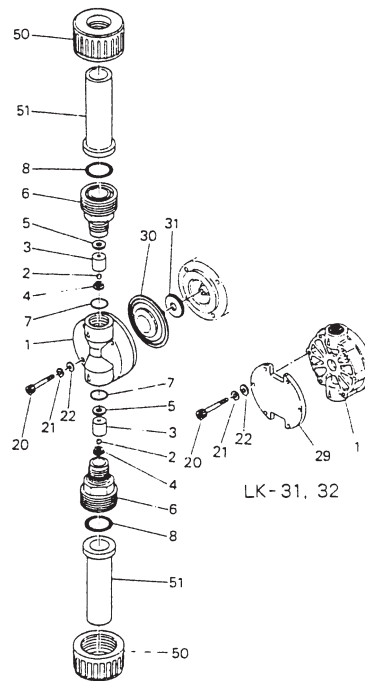

No.	Parts name	Q'ty	Material		
			VCU	VHU	VSU
1	Pump head	1	PVC	PVC	PVC
2	Valve (ball check)	2	ALUMINA CERAMIC	HASTELLOY C	HASTELLOY C
3	Valve guide	2	PVC	PVC	PVC
4	Valve seat	2	FKM	EPDM	SUS304
5	Valve gasket	2	PTFE	PTFE	PTFE
6	Adapter	2	PVC	PVC	PVC
7	O-ring	2	FKM	EPDM	EPDM
8	O-ring	2	FKM	EPDM	EPDM

No.	Parts name	Q'ty	Material	Remarks		
				LK-F11	LK-F21, 22	LK-F31, 32
20	Hex. socket bolt	-	STNLS STL	M4 × 35 4PCS		
20	Hex. head bolt	-	STNLS STL		M5 × 30 4PCS	M5 × 45 6PCS
21	Spring washer	-	∕	4PCS	4PCS	6PCS
22	Plate washer	-	∕	4PCS	4PCS	6PCS
29	Reinforcing plate	-	Steel	—	—	1PC
30	Diaphragm	1	PTFE+EPDM			
31	Retainer	1	SUS304			
50	Nut*	2	PVC			
51	Union (socket)*	2	∕			

Note: The parts asterisked (*) are supplied as a unit.

■ LK-F45, 47 VHH, VCH, VSH (LK-F45 only)

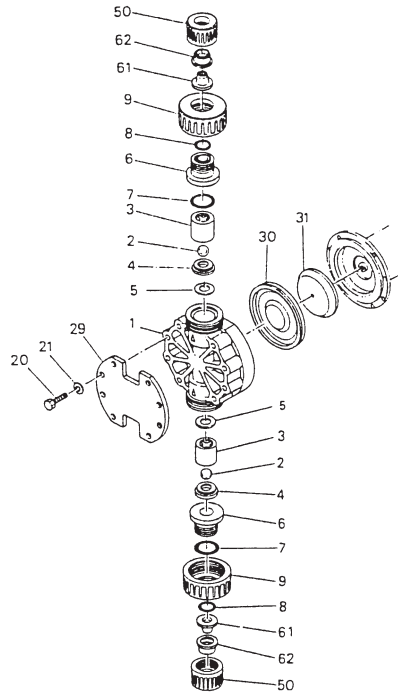

No.	Parts name	Q'ty	Material		
			VCH	VHH	VSH
1	Pump head	1	PVC	PVC	PVC
2	Valve (ball check)	2	ALUMINA CERAMIC	HASTELLOY C	HASTELLOY C
3	Valve guide	2	PVC	PVC	PVC
4	Valve seat	2	PVC	PVC	SUS304
5	Valve gasket	2	PTFE	PTFE	PTFE
6	Adapter	2	PVC	PVC	PVC
7	O-ring	2	FKM	EPDM	EPDM
8	O-ring	2	FKM	EPDM	EPDM
9	Nut	1	PVC	PVC	PVC

No.	Parts name	Q'ty	Material	Remarks
				LK-F45, 47
20	Hex. head bolt	8	STNLS STL	M8 × 60
21	Spring washer	8	〃	
29	Reinforcing plate	1	Steel	
30	Diaphragm	1	PTFE+EPDM	
31	Retainer	1	SUS304	
50	Nut*	2	PVC	
61	Tube insert	2	〃	
62	Ferrule	2	Steel	

Note: The parts asterisked (*) are supplied as a unit.

■ LK-F45, 47 VCU, VHU, VSU (LK-F45 only)

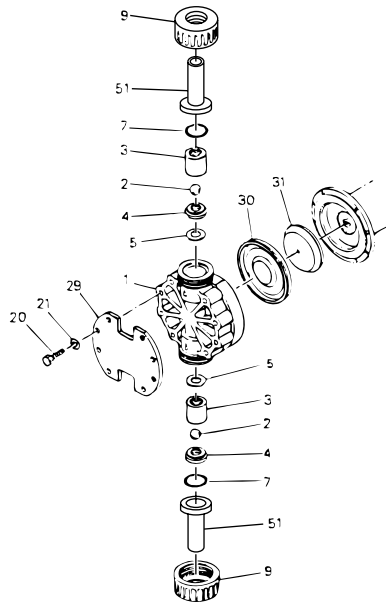

No.	Parts name	Q'ty	Material		
			VCU	VHU	VSU
1	Pump head	1	PVC	PVC	PVC
2	Valve (ball check)	2	ALMINA CERAMIC	HASTELLOY C	HASTELLOY C
3	Valve guide	2	PVC	PVC	PVC
4	Valve seat	2	PVC	PVC	SUS304
5	Valve gasket	2	PTFE	PTFE	PTFE
7	O-ring	2	FKM	EPDM	EPDM
9	Nut	1	PVC	PVC	PVC

No.	Parts name	Q'ty	Material	Remarks
				LK-F45, 47
20	Hex. head bolt	8	STNLS STL	M8 × 60
21	Spring washer	8	〃	
29	Reinforcing plate	1	Steel	
30	Diaphragm	1	PTFE+EPDM	
31	Retainer	1	SUS304	
51	Union (socket)*	2	PVC	

■ LK-F45, 47, 55, 57 VC, VH, VS

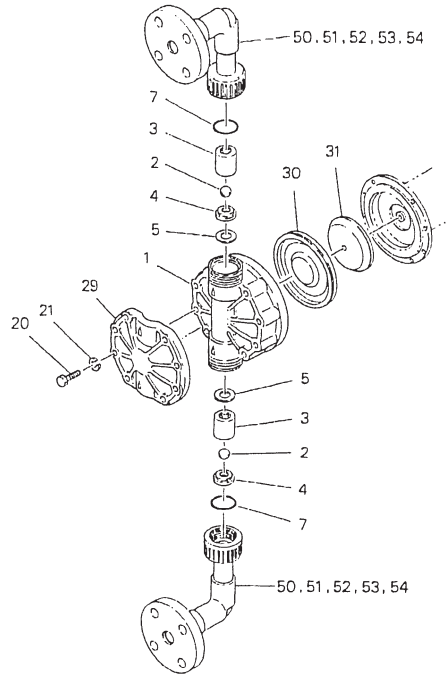

No.	Parts name	Q'ty	Material		
			VC	VH	VS
1	Pump head	1	PVC	PVC	PVC
2	Valve (ball check)	2	ALUMINA CERAMIC	HASTELLOY C	HASTELLOY C
3	Valve guide	2	PVC	PVC	PVC
4	Valve seat	2	PVC	PVC	SUS304
5	Valve gasket	2	PTFE	PTFE	PTFE
7	O-ring	2	FKM	EPDM	EPDM

No.	Parts name	Q'ty	Material	Remarks	
				LK-F45, 47	LK-F55, 57
20	Hex. head bolt	8	STNLS STL	M8 × 60	M8 × 75
21	Spring washer	8	〃		
29	Reinforcing plate	1	FC200	—	—
30	Diaphragm	1	PTFE+EPDM		
31	Retainer	1	SUS304		
50	Nut*	2	PVC		
51	Union (socket)*	2	〃		
52	Elbow*	2	〃		
53	Pipe*	2	〃		
54	Flange*	2	〃		

Note: The parts asterisked (*) are supplied as the flange unit.

■ LK-F11, 21, 22, 31, 32 S6

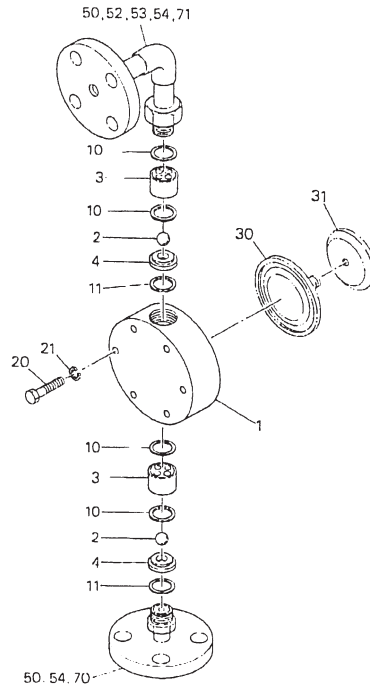

No.	Parts name	Q'ty	Material
1	Pump head	1	SUS316
2	Valve (ball check)	2	HASTELLOY C
3	Valve guide	2	SUS316
4	Valve seat	2	SUS316
10	Valve gasket A	4	PTFE
11	Valve gasket B	2	PTFE

No.	Parts name	Q'ty	Material	Remarks		
				LK-F11	LK-F21, 22	LK-F31, 32
20	Hex. head bolt	–	STNLS STL	M4 × 40 4PCS	M5 × 35 4PCS	M5 × 45 6PCS
21	Spring washer	–	STNLS STL	4PCS	4PCS	6PCS
30	Diaphragm	1	PTFE+EPDM			
31	Retainer plate	1	SUS304			
50	Nut*	2	SUS304			
52	Elbow*	1	SUS316			
53	Pipe*	1	SUS316			
54	Flange*	2	SUS316			
70	Suction port*	1	SUS316			
71	Discharge port*	1	SUS316			

Note: The parts asterisked (*) are supplied as the flange unit.

■ LK-F45, 47, 55, 57 S6

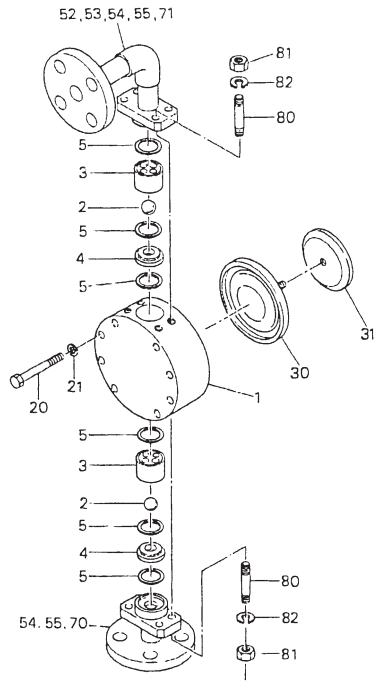

No.	Parts name	Q'ty	Material
1	Pump head	1	SUS316
2	Valve (ball check)	2	HASTELLOY C
3	Valve guide	2	SUS316
4	Valve seat	2	SUS316
5	Valve gasket	6	PTFE

No.	Parts name	Q'ty	Material	Remarks	
				LK-F45, 47	LK-F55, 57
20	Hex. head bolt	8	STNLS STL	M8 × 65	M8 × 65
21	Spring washer	8	STNLS STL		
30	Diaphragm	1	PTFE+EPDM		
31	Retainer plate	1	SUS304		
52	Elbow*	1	SUS316		
53	Pipe*	1	SUS316		
54	Flange*	2	SUS316		
55	*Setting flange	2	SS400		
70	Suction port*	1	SUS316		
71	Discharge port*	1	SUS316		
80	Stud bolt	8	STNLS STL		
81	Hex. nut	8	STNLS STL		
82	Spring washer	8	STNLS STL		

Note: The parts asterisked (*) are supplied as the flange unit.

5. Description on Main Unit and Label

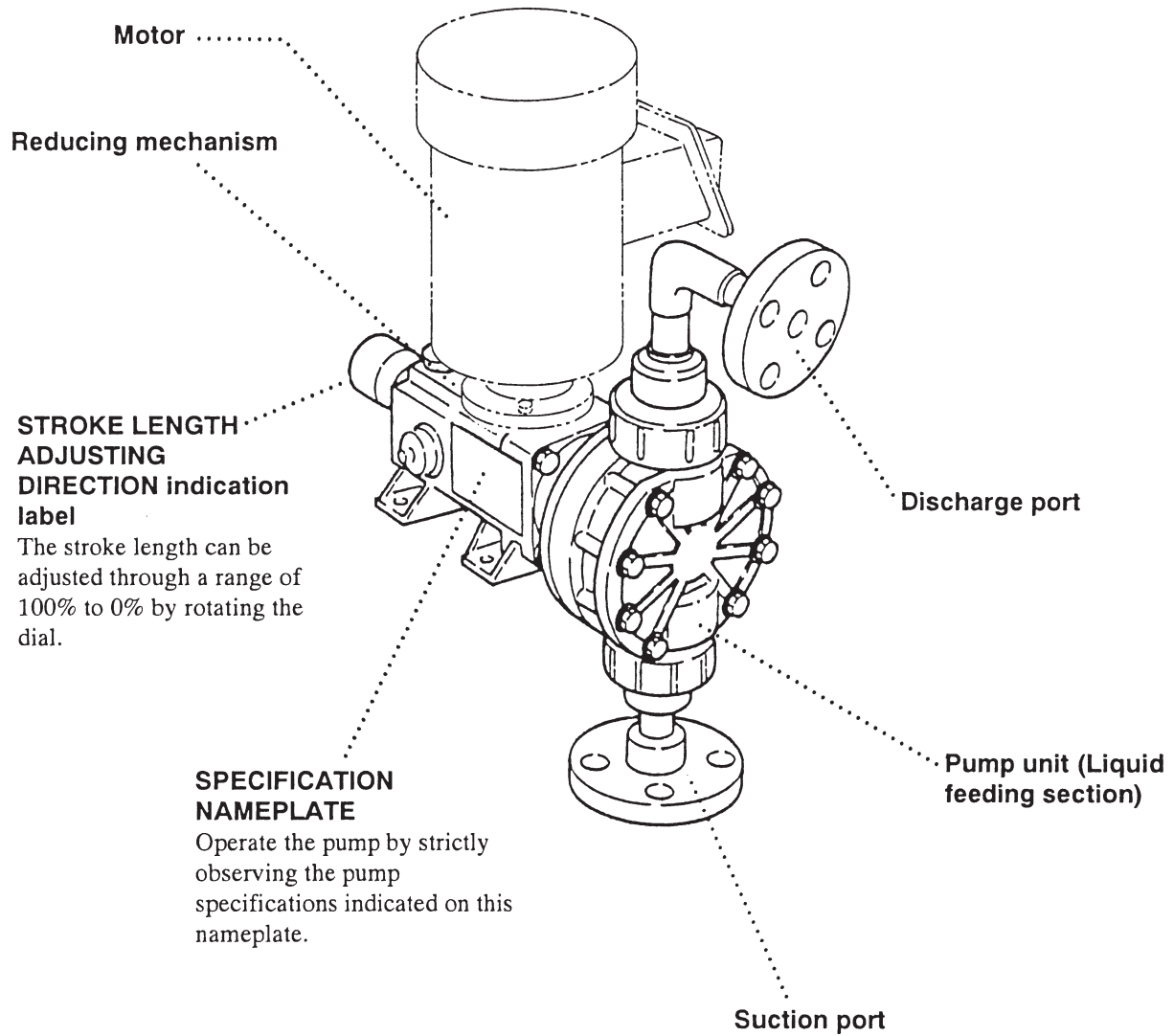

 **CAUTION**



Do not use any solvent when wiping the nameplate, labels, or the pump main unit.

PUMP OPERATION

1. <i>Handling Instructions</i>	22
2. <i>Installation</i>	24
3. <i>Piping</i>	25
4. <i>Wiring</i>	27
5. <i>Operation Step</i>	27

1. Handling Instructions

(Observe all the following instructions to prevent injuries and accidents.)

 Warning
<ul style="list-style-type: none">● Do not operate the pump for the circulation of hazardous mediums (such as explosive, combustible, flammable, or toxic substances, as well as corrosive or irritating substances considered harmful to human health).
 Caution
<ul style="list-style-type: none">● Read the following information prior to installing the pump.● Protective wear: When operating the pump or working near it, with the pump system loaded with chemical liquid, always wear protective clothing, face guard, goggles, and gloves. Further precautionary measures must be taken depending upon the type of liquid used.● Pump repair beyond the range specified in this instruction manual: Do not try to disassemble or repair the pumps by yourself.

[1] Handle the pump carefully.

Strong impacts caused by dropping the pump on the floor or striking it may result in damage or faulty performance.

[2] Do not operate the pump in the following places.

- Places where the temperature falls below 0°C
- Places where corrosive gas or explosive gas is generated
- Places exposed to splashing water
- Places where the ambient temperature is above 55°C
- Places filled with or likely to be filled with explosive or corrosive atmosphere
- Danger due to dust, fire, earthquake and/or any externally imposed shock

[3] Keep the pump away from fire.

To prevent fire and explosions, do not place dangerous or inflammable substances near the pump.

[4] If pump is damaged

Do not operate a damaged pump, otherwise there may be electricity leakage or electric shocks.

[5] No remodeling

Never try to remodel the pump. This may cause a serious accident or damage.

[6] No disassembly or repair

Users are allowed to disassemble and repair the pump to the degree of the given description in "Disassembly and Assembly" in this manual.

 **Caution**

Pump repair beyond the range specified in this instruction manual:

Do not try to disassemble or repair the pumps by yourself.

* The pump must be repaired by trained and qualified operators only. When it needs to be disassembled and repaired, stop operation and contact the supplier for advice.

[7] Do not close any discharge or suction valve while in operation.

Pump operation with any valve above closed increases the load onto the pump itself and will eventually damage the pump.

[8] Do not turn the stroke adjusting dial while the pump is not operating.

Rotating the stroke adjusting dial while not in operation applies load onto the dial and will eventually damage the pump.

[9] Allowable pressure limit

Set the discharge pressure at the allowable tolerable pressure limit level indicated in the “Specifications” paragraph or lower.

[10] Temperature humidity fluctuation

Temperature fluctuation may not change the performance of the pump itself. However, the liquid may change in terms of its viscosity, pressure, or corrosion resistance. Pay special attention to changes in liquid characteristics as a result of temperature fluctuation.

Liquid temperature range	
Material symbol	VC, VH, VS : 0~50°C
Material symbol	S6 : 0~80°C
Ambient temperature range : 0~40°C	
Humidity range : 35~85%RH	

2. Installation

[1] Installation position

- Install the pump as close to the suction tank as possible and in the lowest position available (for flooded suction).
- * The lift head depends upon the liquid properties, temperature, and length of the suction piping. For details of the setup, consult Iwaki or your dealer.

[2] Indoor and outdoor use

The pump can be operated either indoors or outdoors. However, safety measures should be taken so as not to expose the motor and power distribution unit to flooding or other natural hazards.

[3] Installation site

Select an installation site that is flat and free of vibrations caused by nearby machines. Space sufficient for maintenance work should be provided.

■ Lifting

Lift the pump horizontally so that the lubrication oil will not leak out of the pump drive unit.

■ Foundation preparation (before pump installation)

- [1] The area for anchoring the pump must be greater than the area of the base. If the anchoring area is not enough, the base may be destroyed due to a concentrated load on it.
- [2] If pump operation is to be subject to vibration (resonance with the piping, for example), provide an expansion joint between the pump and the piping. Otherwise, the piping, gauge, etc., may be damaged.
- [3] Installation advice
 - Use anchor bolts to fasten the pump base firmly.
 - Install the pump horizontally.
 - Sufficient space is required to allow cool air from the motor fan to circulate.
 - Allow ample space around the pump for easy and efficient maintenance work.

3. Piping

Tightening torque for piping flange of pump. (In the case of flange with rubber gasket.)

Recommended bolt size and tightening torque for piping flange are as follows.

Model	Bolt size	Tightening torque
LK-F11, 21, 22, 31, 32, 45, 47, VC, VH, VS	M12	21N·m
LK-F55, 57, VC, VH, VS	M16	54N·m
LK-F11, 21, 22, 31, 32, 45, 47 S6	M12	42N·m
LK-F55, 57 S6	M16	78N·m

Load of piping for LK-F

When piping the pump, support the piping and use an expansion joint so as not to apply a load onto the pump discharge/suction piping.

Recommended piping method

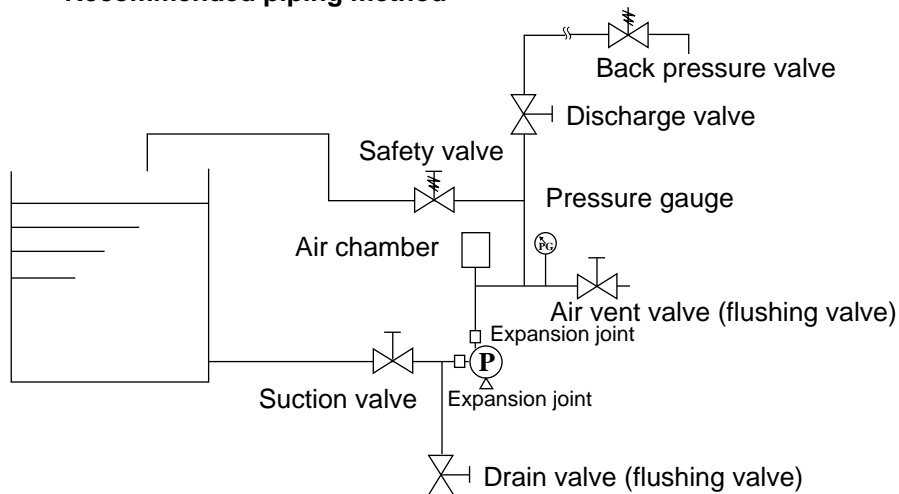

■ General precautions

- (1) All piping should be supported independently so that unnecessary weight and vibration are not transmitted directly to the pump. Expansion joint is recommended to avoid damaging the pump head especially.
- (2) The best piping arrangement for minimum loss is based on straight runs with as few bends and fittings as possible.
- (3) When handling a high or low temperature liquid, provide an expansion joint in a pipe line to allow for stress caused by thermal expansion and contraction.
- (4) When handling a slurry liquid, provide a drain plug at the bottom of piping and do not make a down loop in piping system.
- (5) When handling a viscous, toxic or crystallizable liquid, provide piping for cleaning.
- (6) Use reliable piping materials which can resist pressure and corrosion.
- (7) Clean the inside of pipes before installation. Remove the caps fitted on the pump inlet and outlet before installing piping. The caps are provided for preventing contamination by foreign matter.
- (8) A safety valve should be installed on the discharge line near the pump.

■ Suction piping

- (1) Flooded suction is always recommended.
- (2) The diameter of the suction pipe should never be smaller than the pump inlet.
- (3) The suction piping should be as short as possible. Excessive length may lead to flow instability.
- (4) Air leakage from the joints in the piping system may cause pumping failure or flow instability. Seal the joints firmly.

■ Discharge piping

- (1) Install a safety valve near the pump. Its setting pressure should not exceed the pressure permissible for the pump and pipes.
- (2) Firmly connect and seal the joints.
- (3) Do not fail to install a pressure gauge on the discharge piping.
- (4) Install a pulsation dampener (air chamber or accumulator) in the discharge piping to prevent any fluctuation of pressure. Install the pulsation dampener in a position close to the pump discharge port.

4. Wiring

Electrical connections

ATTENTION



The electrical connection should be carried out by an authorized electrician in accordance with local regulations. Please make sure that the electrical data on the nameplate of the motor correspond to the electricity supply on which it will be used. Motors must be connected to a motor protection switch.

- [1] Use an electromagnetic switch that conforms with the specifications (voltage, capacity, etc.) of the pump motor.
- [2] If using the pump outdoors, waterproof the wiring to protect the switches from rainwater.
- [3] Electromagnetic switches and push buttons should be installed reasonably distant from the pump.

5. Operation Step

■ Operation instructions

- [1] Never operate the pump with the suction and discharge side valve closed. Otherwise, the inside of the pump will be damaged.
- [2] In the event of a service power failure, turn off the power switch immediately and close the discharge valve.
- [3] Maximum pump surface temperature
The max. pump surface temperature of each model is shown in the table. Arrange protective measures in accordance with the temperature levels.

Model	Liquid temp (°C)	Maximum surface temperature when ambient temperature is at 40°C (°C)
LK-F11, 21, 22, 31, 32, 45, 47, 55, 57, VC, VH, VS	50	45
LK-F11, 21, 22, 31, 32, 45, 47, 55, 57 S6	80	75

- [4] Sound generated by pump
The level of sound generated by LK-F type of pump is 85 (dB). Arrange a muffling measures in accordance with the sound level if necessary. The procedure for sound measurement conforms to the EN 31201 (ISO11201).

■ Preparation for start-up

Preparations should be made, as described below, in the case of initial operation after installation and in the case of restarting of operation after a long period of inactivity.

- [1] Thoroughly clean the inside of the tank and pipe. Then, supply liquid.
- [2] Tighten the flange connecting bolts and the installation bolts on the base.
- [3] Check every part of the pump for defects, loosened bolts, oil leakage, etc.
- [4] Check the oil gauge to see if the drive unit is filled with the specified amount of oil.

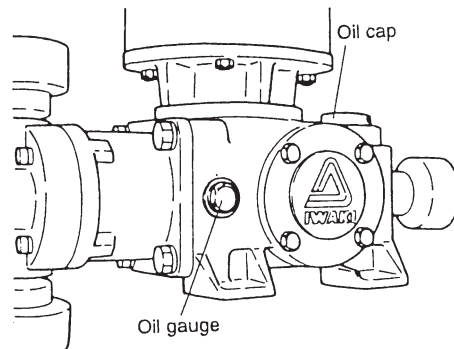

- [5] Run the motor instantaneously to check for correct direction of motor rotation. The motor should run in the direction indicated with the arrow on the pump. If the direction is reversed, exchange any two wires of the three-phase power wires.

■ Operation

- [1] Open the valves of the suction and discharge pipes.

Caution

DO NOT OPERATE THE PUMP WITH THE VALVES CLOSED.

- [2] Turn on the power switch of the motor.
- [3] Loosen the hex. socket head bolt of the stroke length dial. Set the stroke length at 0% by turning the stroke length dial.

Caution

DON NOT TURN THE DIAL WHILE THE PUMP IS NOT OPERATING.

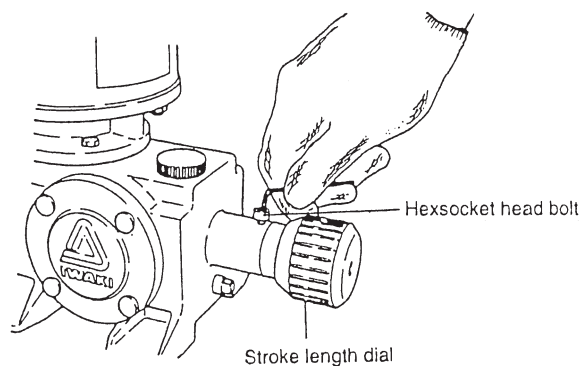

-
- [4] Continue to run the pump for 30 minutes or longer to let it warm up. Check that no abnormality is found. This procedure is necessary only during at the first operation, but when the ambient temperature is extremely low, continue no-load running until the oil temperature rises sufficiently because the motor may sometimes be overloaded a little due to an increase in the viscosity of oil in the drive unit.
 - [5] Open an air vent valve to purge the discharge line for air.
 - [6] Increase the stroke length up to 100% and continue to run the pump for 30 minutes or longer again.
 - [7] Close the air vent valve gradually, watching the pressure gauge. The liquid will come into the discharge line and be discharged from the end of the pipe. Should the discharge pressure exceed the permissible pressure for the pump before the air vent valve is completely closed, check the piping system.
 - [8] Check that the motor amperage does not exceed the rated one and that no abnormality is found.

■ **Metering**

- [1] Operate the pump using the liquid to be actually used.
- [2] Setting the stroke length at 100%, determine the discharge capacity per minute several times. If no noticeable variation is found after repeated measuring, the pump is working normally.
- [3] Measure the discharge capacity at two or three points of the stroke length. When a set point is changed, measure the discharge capacity after running one minute or longer.
- [4] Make a pump calibration curve using the results of the above procedures.
 - [Note] Our in-plant test data, available on request, is based on pumping water at normal ambient temperature with a short piping system. Therefore, there will be a difference between the test data and the practical performance data.
- [5] The relation between amount of stroke length dial revolution and stroke length is shown in the following graphs.

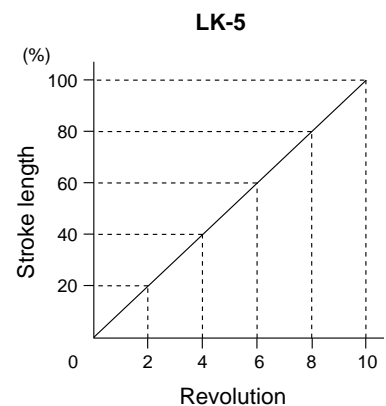
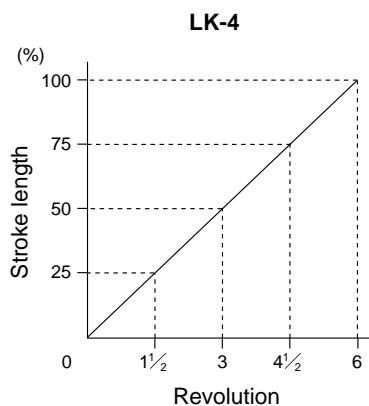
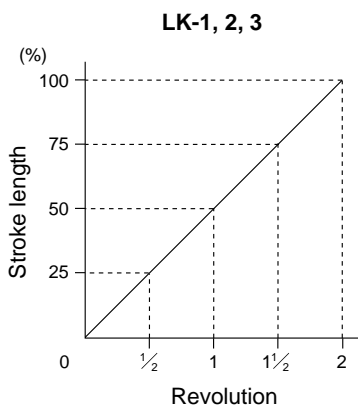

■ **Starting after the pump is stoped or out of use**

- [1] When the pump is stopped for a short period of time (within a week), it can be started as it is at a prescribed pressure and capacity.
- [2] When the pump has been out of use for a long period of time, operate the pump at zero pressure for a few minutes to lubricate it thorough. Do not start the pump at a prescribed pressure immediatly.

■ **Pulsation dampener**

It is always recommended to install a pulsation dampener, i.e. diaphragm type accumulator, air chamber, etc. Because a metering pump is a reciprocating device, it produces pressure pulsations that the system sees in the forms of acceleration, inertia, shock, noise, and reduced service life. Especially when a piping is long, use a pulsation dampener for accurate metering. Air should be periodically supplied to the air chamber (having no membrane) because the air, compressed by the liquid, gradually dissolves in the liquid as time passes, resulting in insufficient air volume.

MAINTENANCE

1. <i>Causes of Trouble and Troubleshooting</i>	32
2. <i>Maintenance and Inspection</i>	34
3. <i>Consumable Parts</i>	35
4. <i>Disassembly and Assembly</i>	36

1. Causes of Trouble and Troubleshooting

Refer to this "1. Causes of Trouble and Troubleshooting". Consult supplier for more information.

If you find any troubles, turn off the power supply immediately.

Item	Problems	Ref. No. for cause/countermeasures
A	Discharge capacity is short.	1, 2, 4, 5, 6, 7, 8, 9, 11, 12
B	Discharge capacity is excessive.	3, 7, 9
C	Discharge capacity is unstable.	1, 2, 3, 4, 5, 7, 8, 11, 12
D	No liquid is discharged.	1, 2, 4, 7, 8, 11, 12
E	Discharge pressure does not rise.	1, 2, 4, 8, 10, 11, 12
F	Liquid is not being sucked.	1, 2, 4, 5, 6, 7, 8, 12
G	Liquid leaks.	5, 6
H	Motor does not run.	15, 16, 17, 18, 19
I	Excessive amperage is applied to motor.	13, 15, 16, 17, 19
J	Excessive vibration and loud noise.	8, 12, 13, 15, 19
K	Oil leaks.	14
L	Gear box is excessively heated.	7, 13, 19

Ref.	Cause	Countermeasures
1	Foreign matter is clogging valve ball, valve seat and/or valve guide.	Disassemble and clean.
2	Valve seat and/or valve ball is worn.	Replace.
3	Differential pressure is inadequate.	Install a back-pressure valve in discharge line. (0.3 bar is required as min. differential pressure.)
4	Air leaks into suction line.	Inspect suction pipes and connections. Re-tighten.
5	Defect of valve gasket or O-ring	Replace.
6	Damage to diaphragm	Replace. Check discharge pressure and foreign matter or crystallization in pump chamber if its life is too short.
7	Pumping condition (liquid, temperature, pressure, piping, etc.) is altered.	Renew pump performance data regarding altered pumping condition after confirming that pump is suitable.
8	Suction pipe or strainer is clogged.	Disassemble and clean.
9	Stroke length dial is shifted.	Readjust and tighten lock bolt securely after confirming that no liquid is discharged at stroke length of 0%.
10	Dust is clogging mouth of pressure gauge or pressure gauge is defective.	Clean or replace.
11	Leak from safety valve	Readjust pressure setting or replace if it is defective.

Ref.	Cause	Countermeasures
12	Cavitation occurs due to insufficient NPSH required.	Examine suction condition. Refer to foot note.
13	Lubricating oil of drive unit is not proper.	Check that specified oil is used. Check oil quantity and stain. Replenish or replace if necessary.
14	Defect of oil seal or O-ring	Replace.
15	Defect of motor	Replace.
16	Wrong wiring or defect of contact	Check wiring. Replace switch, etc. if necessary.
17	Voltage drop	Inspect cause and take countermeasures accordingly.
18	Fuse is burnt.	Inspect cause and take countermeasures accordingly.
19	Overload (excessive discharge pressure)	Check discharge line and take countermeasures for lowering pressure.

Note:NPSHr of each model is as follows.

Pump Model	NPSHr (m)
LK-F 11	7.3
LK-F 21 LK-F 22	7.3
LK-F 31	7.3
LK-F 32	8.3
LK-F 45 LK-F 47	7.3

2. Maintenance and Inspection

■ Daily inspection

[1] Check whether the pump operates smoothly, without generating any abnormal noise or vibration.

[2] Check the level of the liquid in the suction tank.

[3] Check for no leakage.

[4] Check the drive unit for oil loss and leakage.

[5] Compare the discharge pressure and electric current measured during operation with the values indicated on the motor nameplate for the verification of normal pump load.

* Note that the values indicated on the pressure gauge vary in proportion to the specific gravity of the liquid. The cock of the pressure gauge must be opened only when measurement is carried out. It must be closed upon the completion of each measurement. If the cock remains open during pump operation, the meter mechanism may be affected by noise or vibration.

[6] If a spare pump is available, activate it from time to time to keep it ready for use any time.

Check to be sure there is no liquid leakage in the pump before operating it. If leakage is detected, never try to operate the pump.

[7] Check to be sure the discharge pressure, discharge flow rate, and motor power supply voltage do not fluctuate during pump operation. If considerable fluctuation of the respective values occurs, refer to "1. Causes of Trouble and Troubleshooting" for correct measures.

■ Periodic inspection

To ensure efficient and smooth operation of the pump, carry out periodic inspections by following the procedures described below. When inspection, overhauling, or repair work is necessary, stop the pump operation and contact the supplier.

The overhauling and repair work for Iwaki pumps must be performed by qualified personnel who have been trained and certified by the pump supplier. User's failure to observe this instruction exempts Iwaki from the responsibility for personal injury or damage to the equipment or facility which result from its misuse.

[1] Valve Unit

Check the valve balls, valve seats and valve guides every 6 months. If flaws or worn parts are found, replace them.

[2] Diaphragm

Check the diaphragm every 6 months if the usage is fairly light. The life of the diaphragm depends on the characteristics, pressure, temperature, etc. of the liquid being pumped. If any deformation or crack is found, the diaphragm should be replaced with a new one.

[3] Oil

Change the oil in the drive unit once a year. If emulsification of the oil is found, immediately change the oil.

Remove the drain plug and drain the drive unit. Flush the inside with oil to clean it. Then, add new oil up to the specified level of the oil gauge.

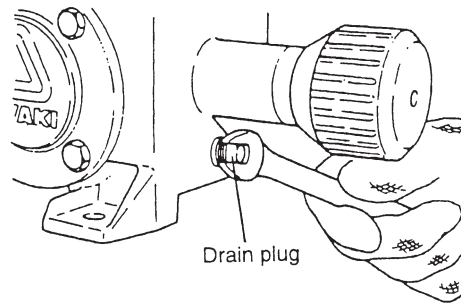

Model	Oil Q'ty	Recommended Oil
LK-F	0.22 Lit.	Esso (EXXON) GP80W-90, Shell SPIRAX/EP80, Mobil PEGASUS GEAR OIL 80.

Contact your Iwaki agent when the oil listed above is unavailable. Other kinds of oil may shorten life-term of the gear unit.

3. Consumable Parts

Consumable parts shown on table below must be replaced at the time of replacement shown as below.

Parts No.	Parts	Time to be replaced
2	Valve	12 months
3	Valve guide	
4	Valve seat	
5	Valve gasket	
7,8	O ring	
30	Diaphragm	4,000 hours

Note 1. Time to be replaced is based on pumping clear water at ambient temperature and it depends on characteristics, temperature and other conditions of pumped liquid.

2. O ring must be replaced every time when pump is disassembled regardless of the time to be replaced mentioned above.

3. Refer to pages 12 to 19 for parts no.

4. Disassembly and Assembly

Refer to exploded view of the model corresponding to your pump. The views are shown on "name of parts."

Caution

- Before disassembling/assembling the pump, do not fail to turn off the main power supply. Display a board "WORKING" near the power switch to let other personnel know the situation. Power ON initiated by any other person than the operator/service man may result in an accident. The operator has the responsibility to take special precautions to prevent this.
- Prior to disassembly or assembly, close the suction valve and discharge valve fully.
- The piping and the pump often retain liquid. When a dangerous liquid is handled, wear protectors (goggles, rubber gloves, etc.) when disconnecting the pipes.

■ **Disassembly**

- [1] Disassemble only after thoroughly washing out the liquid inside the pump by use of flushing piping, clean the inside of the pump.

Warning

Wear protectors (goggles, rubber gloves, etc.).
Certain liquids are dangerous. They may hurt your eyes and skin.

- [2] Remove the discharge and suction piping.

Caution

Close the suction valve and discharge valve fully.

1. Valve

- (1) Remove the suction and discharge flange unit by loosening the nut (50).

Remove the adapter (6) if any, and take out the valve (2), valve guide (3), valve seat (4), valve gasket (5) and O-ring (7). If the pump head is made of stainless steel, the valve assembly can be taken out by loosening the setting flange (54) or the nuts (81).

- (2) Check the valve and valve seat, and if a flaw or wear is found, replace it with a new one. It is recommended to replace the gasket and O-ring every time.

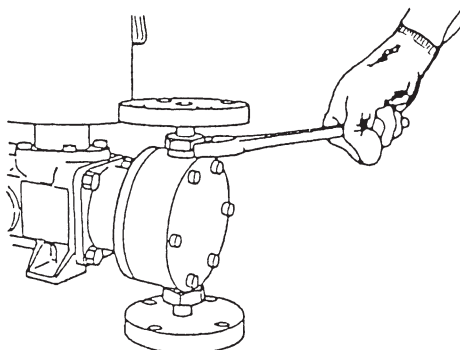
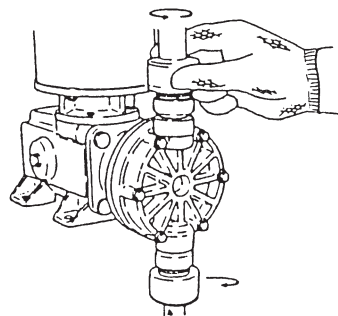

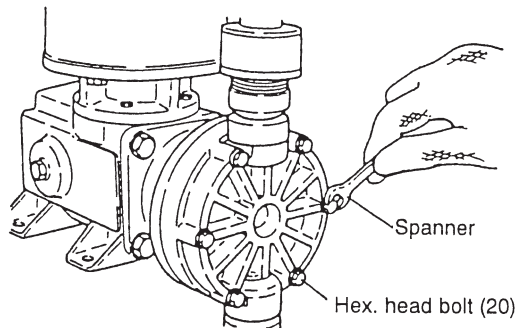

2. Diaphragm

- (1) Loosen the hex. head bolts (20). Loosen the hex. socket bolts (20), if any.
- (2) Remove the pump head (1).
- (3) Connect power supply and run the motor temporarily.

Set stroke length to 100%. Turn off when the diaphragm comes to the top dead point.

Disconnect power supply.

Caution

Do not touch any moving parts during operation.

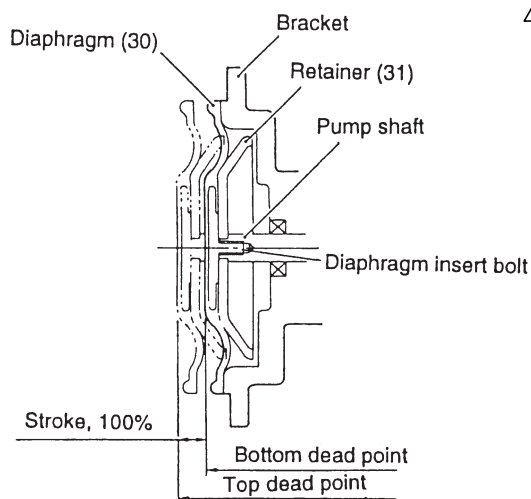

- (4) Remove the diaphragm from the pump shaft by turning the diaphragm counterclockwise with hand. If any worn or deformed part is found, replace it with a new one.
- (5) Fix the new diaphragm firmly to the pump shaft by turning it clockwise with hand. Confirm that the retainer (31) is firmly seated in a depression of the diaphragm insert bolt and touches the end of the pump shaft. Should the position of the pump shaft be changed after reassembling the diaphragm, set it at the top dead point, following the above procedure (3).

■ Assembly

The pump should be assembled by carrying out the steps of disassembly in reverse. Pay attention to the following points.

1. Valve

- (1) Replacement of O ring and gasket

When replacing the O ring or gasket, be sure to install a new one. In addition, see that the O ring or gasket is not twisted or pressed by another part.

* The sealing section should be cleaned free of dust or scratches before installation.

- (2) Assemble the valve assembly by reversing the procedure, taking special care with the direction and position of the valve guide, valve seat and valve gasket.

Caution

If the direction or position is mistaken in assembling the valve guide, valve ball, or valve seat, the pump may be damaged.

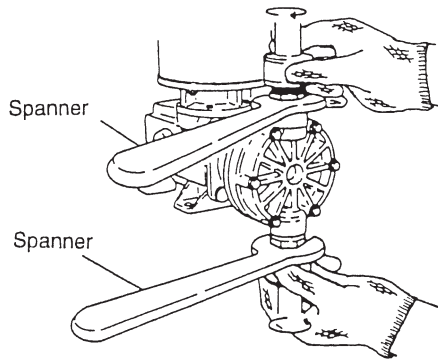

(3) When installing a LK-F 11, 21, 22, 31, or 32 flange (VC, VH, or VS type), use a spanner to fix the adapter (6) then fasten the nut (50) by hand.

2. Diaphragm

(1) Connect power supply and run the motor temporarily, and move the diaphragm to the bottom dead point where the diaphragm is fully drawn back.

Turn off motor.



Caution

Do not touch any moving parts during operation.

(2) Fit the pump head (1) to the bracket of the drive unit with the hex. head bolts (20), if any.

Tighten all the bolts securely and uniformly.

Tightening torque for bolts (20)					unit : Nm
	LK-F 11	LK-F 21, 22	LK-F 31, 32	LK-F 45, 47	LK-F 55, 57
VC, VH, VS	2.2	3.0	3.0	12.0	12.0
S6	2.2	3.0	5.0	12.0	12.0



IWAKI CO.,LTD. 6-6 Kanda-Sudacho 2-chome Chiyoda-ku Tokyo 101-8558 Japan

()Country codes

TEL:(81)3 3254 2935 FAX:3 3252 8892(<http://www.iwakipumps.jp>)

Germany	: IWAKI EUROPE GmbH	TEL : (49)2154 9254 0	FAX : 2154 1028	U.S.A.	: IWAKI WALCHEM Corporation	TEL : (1)508 429 1440	FAX : 508 429 1386
Italy	: IWAKI Italia S.R.L.	TEL : (39)02 990 3931	FAX : 02 990 42888	Australia	: IWAKI Pumps Australia Pty. Ltd.	TEL : (61)2 9899 2411	FAX : 2 9899 2421
Denmark	: IWAKI Pumper A/S	TEL : (45)48 24 2345	FAX : 48 24 2346	Singapore	: IWAKI Singapore Pte. Ltd.	TEL : (65)6763 2744	FAX : 6763 2372
Sweden	: IWAKI Sverige AB	TEL : (46)8 511 72900	FAX : 8 511 72922	Indonesia	: IWAKI Singapore (Indonesia Branch)	TEL : (62)21 690 6606	FAX : 21 690 6612
Finland	: IWAKI Suomi Oy	TEL : (358)9 2742714	FAX : 9 2742715	Malaysia	: IWAKIm Sdn. Bhd.	TEL : (60)3 7803 8807	FAX : 3 7803 4800
Norway	: IWAKI Norge AS	TEL : (47)66 81 16 60	FAX : 66 81 16 61	Taiwan	: IWAKI Pumps Taiwan Co., Ltd.	TEL : (886)2 8227 6900	FAX : 2 8227 6818
France	: IWAKI France S.A.	TEL : (33)1 69 63 33 70	FAX : 1 64 49 92 73	Thailand	: IWAKI (Thailand) Co.,Ltd.	TEL : (66)2 322 2471	FAX : 2 322 2477
U.K.	: IWAKI PUMPS (UK) LTD.	TEL : (44)1743 231363	FAX : 1743 366507	Hong Kong	: IWAKI Pumps Co., Ltd.	TEL : (852)2 607 1168	FAX : 2 607 1000
Switzerland	: IWAKI (Schweiz) AG	TEL : (41)26 674 9300	FAX : 26 674 9302	China	: IWAKI Pumps (Guandong) Co., Ltd.	TEL : (86)750 380 9018	FAX : 750 380 9078
Austria	: IWAKI (Austria) GmbH	TEL : (43)2236 33469	FAX : 2236 33469	China	: GFTZ IWAKI Engineering & Trading (Guangzhou)	TEL : (86)20 8435 0603	FAX : 20 8435 9181
Holland	: IWAKI Holland B.V.	TEL : (31)297 241121	FAX : 297 273902	China	: IWAKI Pumps Co., Ltd. (Beijing)	TEL : (86)10 6442 7713	FAX : 10 6442 7712
Spain	: IWAKI Iberica Pumps, S.A.	TEL : (34)943 630030	FAX : 943 628799	China	: IWAKI Pumps (Shanghai) Co., Ltd.	TEL : (86)21 6272 7502	FAX : 21 6272 6929
Belgium	: IWAKI Belgium n.v.	TEL : (32)1367 0200	FAX : 1367 2030	Philippines	: IWAKI Chemical Pumps Philippines, Inc.	TEL : (63)2 888 0245	FAX : 2 843 3096
				Korea	: IWAKI Korea Co.,Ltd.	TEL : (82)2 3474 0523	FAX : 2 3474 0221