

John Deere

CLICK ANYWHERE FOR MORE DETAILS

MODEL:

Fuel Injection
Pump/Nozzle

MANUAL PREVIEW

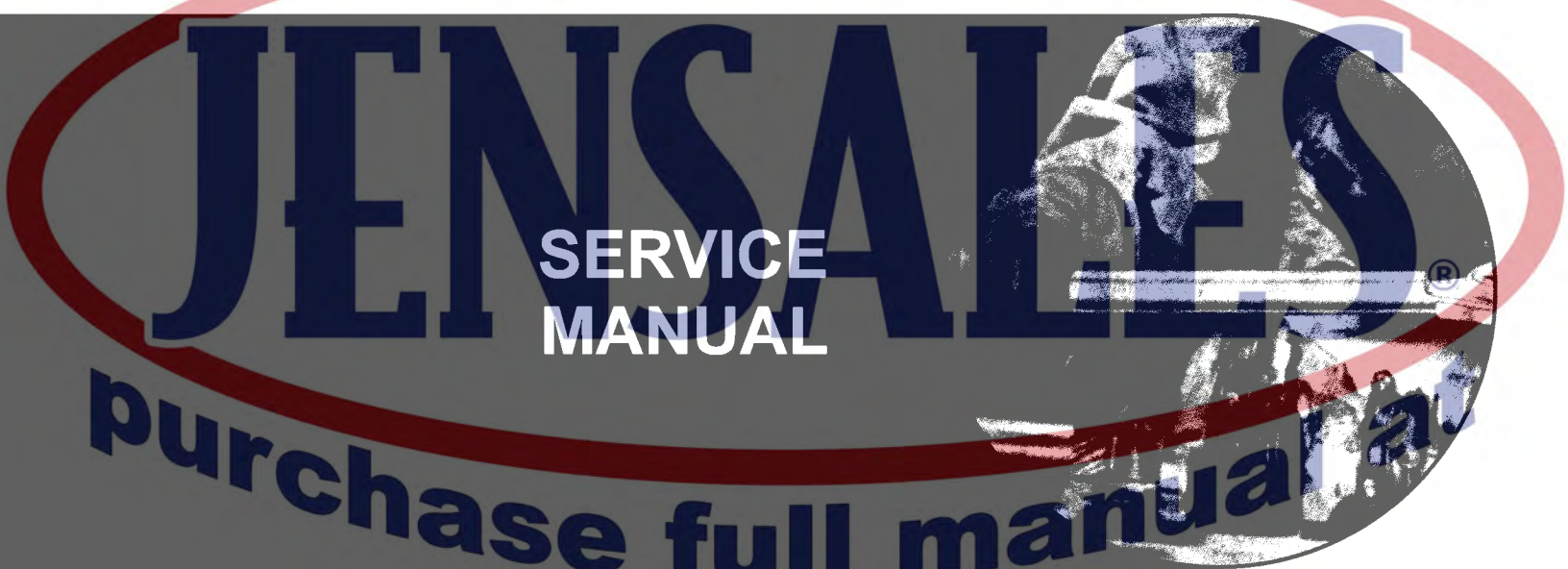

JENSALES.COM

or Call 800-443-0625



CLICK ANYWHERE FOR MORE DETAILS

THIS IS A MANUAL PRODUCED BY JENSALES INC. WITHOUT THE AUTHORIZATION OF JOHN DEERE OR IT'S SUCCESSORS. JOHN DEERE AND IT'S SUCCESSORS ARE NOT RESPONSIBLE FOR THE QUALITY OR ACCURACY OF THIS MANUAL.

TRADE MARKS AND TRADE NAMES CONTAINED AND USED HEREIN ARE THOSE OF OTHERS, AND ARE USED HERE IN A DESCRIPTIVE SENSE TO REFER TO THE PRODUCTS OF OTHERS.

JD-S-SM2045

CLICK ANYWHERE FOR MORE DETAILS

Fuel Injection
Pump/Nozzle

MANUAL PREVIEW

SERVICE MANUAL

Fuel Injection
Pump/Nozzle

SM2045 (01APR81) English

JENSALES®

purchase full manual at

JENSALES.COM
or Call 800-443-0625

CLICK ANYWHERE FOR MORE DETAILS

SM2045 (01APR81)

LITHO IN U.S.A. (REVISED)
ENGLISH

**SERVICE MANUAL FOR
JOHN DEERE DEALERS**

CLICK ANYWHERE FOR MORE DETAILS



**TESTING
AND SERVICING
FUEL INJECTION PUMPS
AND NOZZLES**

Section	Page
5 - PUMP DIAGNOSIS - ALL ROOSA MASTER PUMPS	
Group 5 - Diagnosing Pump Malfunctions	5-5-1
10 - ROOSA MASTER MODEL DB AND JDB PUMPS	
Group 5 - Description and Operation	10-5-1
Group 10 - Service	10-10-1
Group 15 - Bench Test Procedure	10-15-1
Group 20 - DB Pump Specifications	10-20-1
Group 25 - JDB Pump Specifications	10-25-1
11 - ROOSA MASTER MODEL DC PUMPS	
Group 5 - Description and Operation	11-5-1
Group 15 - Service	11-15-1
Group 20 - Bench Test Procedure	11-20-1
Group 25 - Specifications	11-25-1
15 - ROOSA MASTER MODEL C PUMPS	
Group 5 - Description and Operation	15-5-1
Group 10 - Service	15-10-1
Group 15 - Bench Test Procedure	15-15-1
Group 16 - Specifications	15-16-1
Group 25 - Removal and Installation	15-25-1
16 - ROOSA MASTER MODEL CB PUMPS	
Group 5 - Description and Operation	16-5-1
Group 15 - Service	16-15-1
Group 20 - Bench Test Procedure	16-20-1
Group 21 - Specifications	16-21-1
Group 25 - Removal and Installation	16-25-1

All information, illustrations and specifications contained in this service manual are based on the latest information available at the time of publication. The right is reserved to make changes at any time without notice.

(Continued)

CONTENTS—Continued

Section		Page
20	- BOSCH AND SCINTILLA PUMPS	
	Group 5 - Description and Operation	20-5-1
	Group 10 - Service	20-10-1
	Group 15 - Bench Test Procedure	20-15-1
30	- INJECTION NOZZLES	
	Group 5 - Nozzles for Four- and Six-Cylinder Diesel Engines (Waterloo)	30-5-1
	Group 10 - Nozzles for Two-Cylinder Diesel Engines (Waterloo)	30-10-1
	Group 15 - American Bosch Nozzles for Four- and Six- Cylinder Diesel Engines (Dubuque)	30-15-1
	Group 20 - Robert Bosch Nozzles for Four- and Six-Cyl- inder Diesel Engines (Dubuque)	30-20-1
	Group 25 - Roosa Master 9.5-Mm. Injection Nozzles for Waterloo and Dubuque Engines	30-25-1
	Group 26 - Specifications (Roosa-Master 9.5-Mm. Injection Nozzles)	30-26-1
	Group 30 - Robert Bosch 21-Mm. Nozzles	30-30-1
40	- PART AND MODEL NUMBER SPECIFICATIONS INDEX	40-5-1

PURPOSE OF MANUAL

This manual is expressly intended to provide sufficient information for qualified technicians, experienced in diesel engines and diesel injection equipment, to test and service the fuel injection pumps and nozzles used on John Deere tractors and power units and to make such adjustments and parts replacements as may be needed. Inexperienced persons should never make adjustments and repairs to diesel injection equipment as such action may result in very extensive damage to the equipment or to the engine.

NOTE: No service should be performed on injection equipment before making a careful study of the manual and becoming familiar with the principles and instructions which follow:

This manual completely describes the operating principles of the various mechanisms of the pump and nozzles. Only through a thorough knowledge of the principles of the various mechanisms can the serviceman locate and correct possible operational faults.

 This safety alert symbol identifies important safety messages in this manual. When you see this symbol, be alert to the possibility of personal injury and carefully read the message that follows.

 **CAUTION: Escaping fluid under pressure can have sufficient force to penetrate the skin, causing serious personal injury. Before applying pressure to the system, be sure all connections are tight and that lines, pipes and hoses are not damaged. Fluid escaping from a very small hole can be almost invisible. Use a piece of cardboard or wood, rather than hands, to search for suspected leaks.**

If injured by escaping fluid, see a doctor at once. These injuries are best treated by immediate surgical removal of as much of the foreign material as possible.

DISASSEMBLY

NOTE: Refer to the tractor service manual or technical manual for instructions on removing and installing the fuel injection pump.

Before disassembling the pump, remove all external grease and dirt by washing the unit with diesel fuel and blowing it off with a blast of filtered air. Keep constantly in mind that dirt, dust, paint, and foreign matter are the greatest enemies of a fuel injection pump. As an added precaution, to prevent dirt from entering the fuel system while servicing the pump, provide a CLEAN WORK SPACE AND CLEAN TOOLS. BE SURE YOUR HANDS ARE CLEAN.

Use a clean pan into which the parts may be placed during disassembly. Also obtain a pan of clean fuel oil in which the parts may be flushed. It is recommended that these be deep-drawn pans with rounded corners to lessen the chances of dirt pockets.

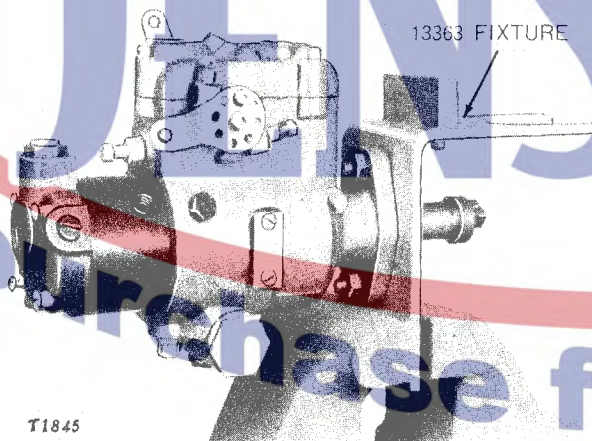

Fig. 10-10-2 -- Pump Mounted for Disassembly

Mount the pump in Roosa Master Fixture No. 13363 (Fig. 10-10-2). Remove all seals. Remove fuel line connections from the head. Unscrew the three cover hold-down screws and remove the governor control cover and cover gasket.

NOTE: On pumps with electric shut-off, remove governor control cover by sliding it toward the drive end of the pump as it is lifted from the pump housing.

Begin disassembly by pulling the drive shaft out of the pump.* The pump body contains an "O" ring drive shaft retainer, which prevents the shaft from falling out during removal from

the engine. It has no function as a seal. The shaft may be easily withdrawn without removing the retainer.

**NOTE: Prior to removing drive shaft on JDB633JT2400 pumps, wire throttle lever in wide open position.*

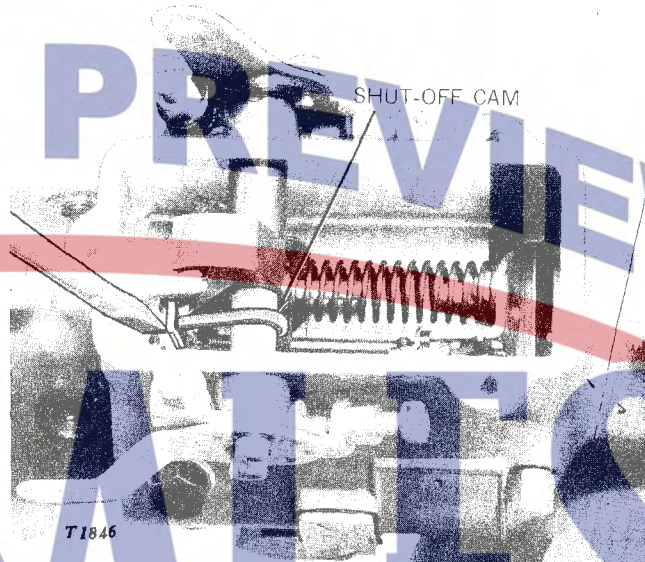

Fig. 10-10-3 -- Removing Shut-Off Cam

Pry shut-off cam (pumps without electric shut-off) and retainer clips off throttle shaft with a flat-bladed screw driver (Fig. 10-10-3).



Fig. 10-10-4 -- Removing Shut-Off Lever and Shaft

Withdraw the shut-off lever and shaft (Fig. 10-10-4).



Fig. 11-15-44—Installing Cam Ring

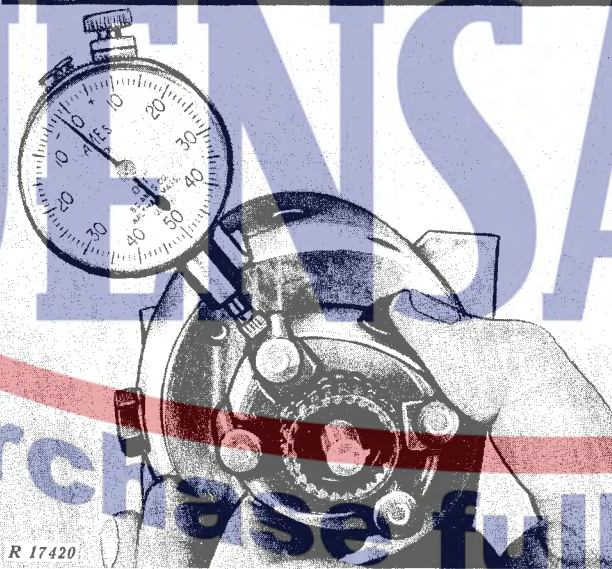

Fig. 11-15-43—Checking Centrality

B. Rotate distributor rotor (either direction) until the next roller depresses dial indicator plunger. Allowable centrality is 0.002 inch (total 0.004 inch). Before making any correction, check and record centrality of all four rollers.

C. If roller centrality is beyond specified tolerance, rollers and/or shoes can be interchanged. Recheck centrality after each change. Be sure to recheck roller-to-roller dimension.

Place cam ring atop hydraulic head with arrow indicating proper direction of pump rotation facing upward (Fig. 11-15-44). Remember that pump rotation is always expressed from drive end. The pump will not deliver fuel with incorrect assembly of cam ring.



Place weight retainer cage with the three rivets face up on work bench. Assemble weight retainer hub on top of weight cage aligning rivets on weight retainer cage in center of elongated slots in hub. Hold snap ring pliers at 45° angle (Fig. 11-15-45). Insert tips of pliers into one of the holes in flexible retaining ring. Holding hub and retainer with one hand, squeeze pliers to expand hole in retaining ring. Push pliers over rivet, catching back edge of hole in ring under head of rivet. Pivot pliers around rivet until ring snaps into position under head of rivet. Repeat this process to assemble retaining ring to remaining five rivets.



Fig. 11-15-45—Installing Retaining Ring