

KOHLER[®] ENGINE ACCESSORIES



KOHLER.Engines

Notes

Table of Contents

| SECTION | PAGE |
|--|-------------|
| Central Distributors – North America | 4 |
| Central Distributors – International | 4 |
| Engine Model Lines | 5-6 |
| Lubrication | 7-9 |
| Starting | 10 |
| Meters, Testers, and Special Tools | 11 |
| Special Items | 12 |
| Ignition and Electrical | 13-16 |
| Guards, Screens, and Blower Housings | 17-19 |
| Front Drive Shafts | 20 |
| PTO | 21 |
| Fuel | 22-24 |
| Controls (Includes coolant and lubrication alert items) | 25-27 |
| Electrical Accessories | 28 |
| Air Intake | 29-35 |
| Exhaust | 36-50 |
| Labels | 51-57 |
| Hang Tags and Cards | 58 |

Distributors



Kohler central distributors are listed on this page. They...and all Kohler dealers...can quickly provide the field-installed accessories in this catalog to keep your KOHLER® engines running smoothly and efficiently.

UNITED STATES

| STATE/PROVINCE | KOHLER CENTRAL DISTRIBUTOR | CITY | PHONE |
|----------------|----------------------------------|------------------|--------------|
| Arizona | Loftin Equipment Co., Inc | Phoenix | 602-272-9466 |
| California | H. G. Makelim Co. | Anaheim | 650-873-4757 |
| | H. G. Makelim Co. | S. San Francisco | 650-873-4757 |
| Colorado | H. G. Makelim Co.—Denver | Aurora | 303-307-8874 |
| Florida | Gardner of Florida, Inc. | Jacksonville | 888-889-3010 |
| Kansas | Medart—Kansas City | Edwardsville | 636-282-2300 |
| Massachusetts | Gardner—Connell | Franklin | 508-543-3600 |
| Minnesota | Central Power Distributors, Inc. | Anoka | 763-576-0901 |
| Mississippi | Medart—Tennessee/Mississippi | Olive Branch, MS | 636-282-2300 |
| Missouri | Medart—St. Louis | St. Louis | 636-282-2300 |
| Ohio | Gardner, Inc.—Ohio | Columbus | 614-456-4000 |
| Oregon | Power Equipment Systems | Salem | 800-782-2700 |
| Tennessee | Medart—Tennessee/Mississippi | Olive Branch, MS | 636-282-2300 |
| Texas | Waukesha-Pearce Industries, Inc. | Houston | 713-723-1050 |
| Virginia | Chesapeake Engine Distributors | Ashland | 804-550-2231 |
| Wisconsin | Central Power Distributors, Inc. | Menomonee Falls | 262-250-1977 |

CANADA

| | | | |
|------------------|-----------------------------|-------------|--------------|
| British Columbia | Magneto Sales | Surrey | 604-888-7240 |
| Manitoba | Yetman's Ltd. | Winnipeg | 204-586-8046 |
| Ontario | CPT—Canada Power Technology | Mississauga | 905-890-6900 |

INTERNATIONAL ~ Visit the Dealer Locator: www.KohlerEngines.com

The Growing Family of KOHLER Engines

SINGLE CYLINDER



Courage® 3.5-4.5 HP
Air-cooled, vertical, OHV
Models: XT6.5, XT6.75, XT8



Courage® 15-22 HP
Air-cooled, vertical, OHV
Models: SV470, 480, 530, 540, 590, 600, 610, 620



Courage® 6.5 HP
Air-cooled, horizontal, OHV
Model: SH265

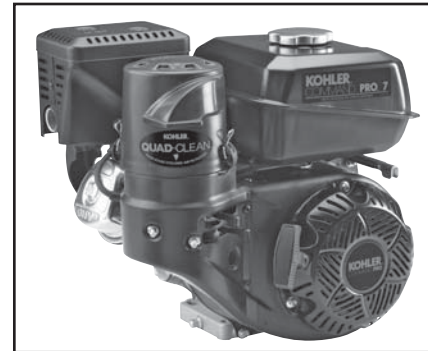

Command PRO® 7-14 HP
Air-cooled, horizontal, OHV
Models: CH270, 395, 440

The Growing Family of KOHLER Engines

TWIN CYLINDER



KOHLER Courage® 20-27 HP
Air-cooled, vertical, OHV
Models: SV710, 715, 720, 730, 735, 740

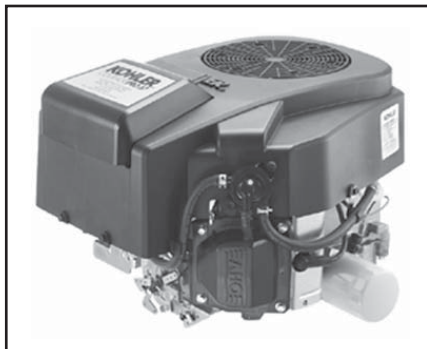

KOHLER Courage PRO™ 20-27 HP
Air-cooled, vertical, OHV
Models: SV810, 820, 830, 840



KOHLER Aegis® 24-31 HP
Liquid-cooled, horizontal, OHV
Models: LH640, 690, 755, 775 EFI



Command PRO® 34-40 HP
Air-cooled, horizontal, OHV
Models: CH940, 960, 980, 1000



Command PRO® 34-40 HP
Air-cooled, vertical, OHV
Models: CV940, 960, 980, 1000



Command PRO® 18-30 HP
Air-cooled, vertical, OHV
Models: CV18, 22, 25, 26, 620, 640, 680, 730, 740, 745 EFI, 750
EFI ECV630, 650, 680, 730, 740, 749



Command PRO® 18-30 HP
Air-cooled, horizontal, OHV
Models: CH18, 20, 22, 25, 26, 620, 640, 680, 730, 740, 745 EFI, 750
EFI ECH630, 650, 680, 730, 740, 749



Command® 18-27 HP
Air-cooled, horizontal, OHV
Models: CH18, 20, 22, 620, 640, 680, 730, 740



Command® 18-27 HP
Air-cooled, vertical, OHV
Models: CV18, 20, 22, 620, 640, 680, 730, 740

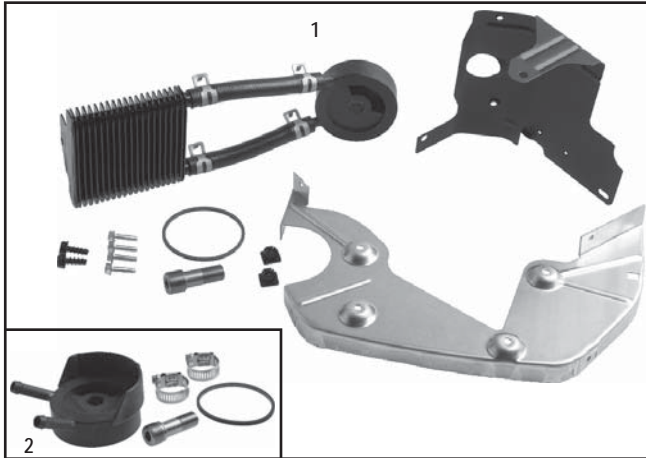

OIL COOLER KIT

To add cooler to engine. Reduces oil sump temperature up to 40°F.

| Kit No. | Adapter Material | Models | Item |
|-----------------------|------------------|--------------------|------|
| 24 755 120-S* | Stanyl | CH/CV17-26/730-750 | 1 |
| 24 029 75-S Base Only | Stanyl | CH/CV17-26/730-750 | 2 |

*Increases engine width on oil filter side by 1.25" (CH twins) or 0.625" (CV twins). Possible interference fit with side mount muffler.

OIL COOLER HOSE

| Part No. | Length | I.D. |
|--------------|----------------|----------------|
| 24 326 17-S* | 450 mm (17.7") | 9.52 mm (3/8") |

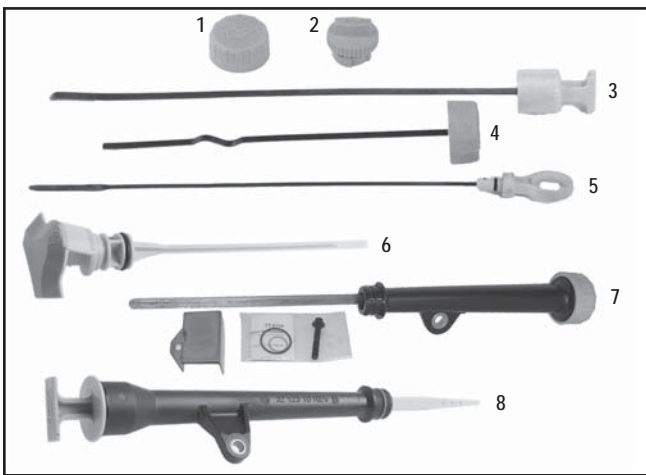

YELLOW ACCESSORIES

| Part No. | Item | Models | Item |
|-----------------|--------------------------------|--|------|
| 24 755 46-S* | Oil fill cap kit | CH18-26/730-750, LH640-775 ECH630-749 | 1 |
| 24 227 02-S** | Oil fill cap assy | CH18-26/730-750, LH640-775 | 2 |
| 12 038 10-S | Dipstick, bent tube | CH11-15 | 3 |
| 12 038 14-S | Dipstick, straight tube | CH11-15 | 3 |
| 12 038 02-S | Dipstick, straight tube | CV11-16/460-493 | 4 |
| 24 038 04-S | Dipstick, straight tube | CV17-26/730-750, ECV630-749 | 4 |
| 66 038 01-S | Dipstick, bent tube | LV625-680 | 4 |
| 24 038 10-S*** | Dipstick, bent/straight tube | CH18-26/730-750, LH640-775 | 5 |
| 20 040 08-S | Dipstick, bent tube (Standard) | SV470-620 | 6 |
| 24 123 22-S**** | Dipstick, tube kit (plastic) | CH18-26/730-750, LH640-775 | 7 |
| 32 755 04-S | Kit | SV710-740/810-840 | 8 |

* For valve cover with pulse-type fuel pump, not mechanical fuel pump. Includes O-ring.

** For valve cover with mechanical fuel pump. Includes O-ring.

*** Used with flared tube for improved seal. Standard since Serial No. 301680011. Earlier standard dipstick 24 038 06-S superseded to 24 755 121-S Kit which includes the 24 038 10-S dipstick and three dipstick tubes to fit all CH twin configurations.

**** Can be used in place of the 1" diameter metal oil fill/dipstick tube for improved seal. Can be used with standard canister-style mufflers. Do not use on applications with crossover manifolds.

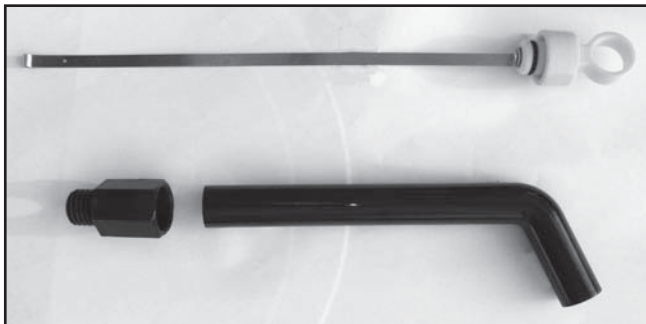

EXTENDED OIL FILL KIT

| Kit No. | Models |
|-------------|-------------|
| 17 755 33-S | CH270-CH440 |

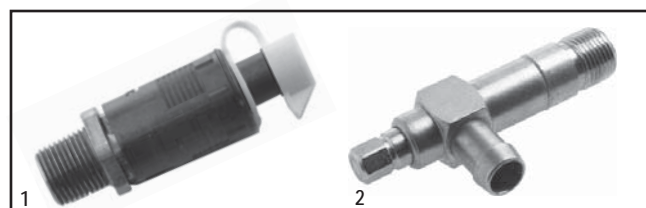

OIL DRAIN VALVE KIT

| Part No. | Drain Hole | Item |
|----------------|--|------|
| 25 755 14-S | 3/8"-18 NPTF Includes 25 173 14-S yellow plastic cap. | 1 |
| 25 462 12-S 2" | 3/8"-18 NPTF | 2 |
| 25 462 13-S 3" | 3/8"-18 NPTF | — |

Lubrication

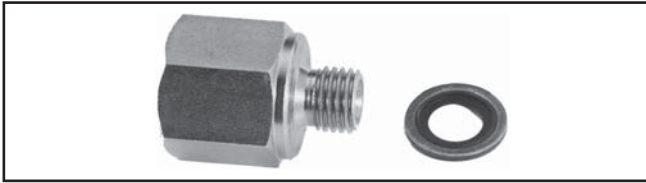

OIL DRAIN ADAPTER

For use with 25 755 14-S Oil Drain Valve Kit (3/8"-18). Includes seal.

| Part No. | Thread, Engine End | Thread, Cap End | Models |
|--------------|--------------------|-----------------|----------------------------|
| 63 755 11-S* | M10-1.25, Male | 1/8"-27, Female | CS4-6, CH270, SH265, WH208 |
| 63 755 10-S | M12-1.5, Male 2 | 3/8"-18, Female | CS8.5-12 |

*Customer must furnish a 1/8"-27 straight pipe (to extend away from engine), and a 3/8"-18 x 1/8"-27 reducer coupling for attaching pipe to Valve Kit.



OIL DRAIN HOSE

For use with 25 755 14-S Oil Drain Valve Kit (3/8"-18).

| Part No. | Length | Thread |
|---------------|--------|---------------------------|
| 24 326 59-S* | 7" | 3/8"-18, Male (both ends) |
| 24 326 66-S** | 12.25" | 3/8"-18, Female (one end) |
| 25 326 05-S** | 28" | 3/8"-18, Female (one end) |

* Also order 25 249 01-S Female Coupling for attaching hose to Valve Kit.

** Also order 24 294 22-S Barbed Fitting and 25 237 02-S Clamp for attaching hose to oil drain hole.

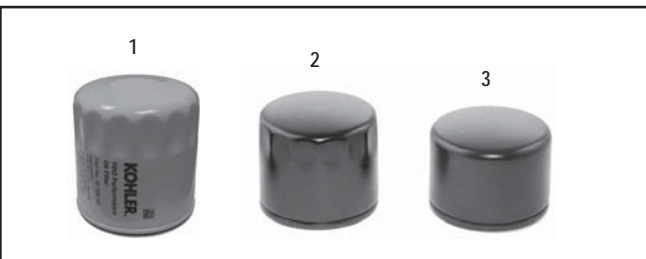

OIL FILTERS

| Part No. | Height | Models | Item |
|--------------|--------|--------------------------------|------|
| 52 050 02-S | 3.11" | Premium filter fits PRO Series | 1 |
| 12 050 01-S | | Standard filter | 2 |
| 28 050 01-S* | 2.32" | | 3 |

* Shorter for applications with interference issues. Approx. 15% less filter capacity.

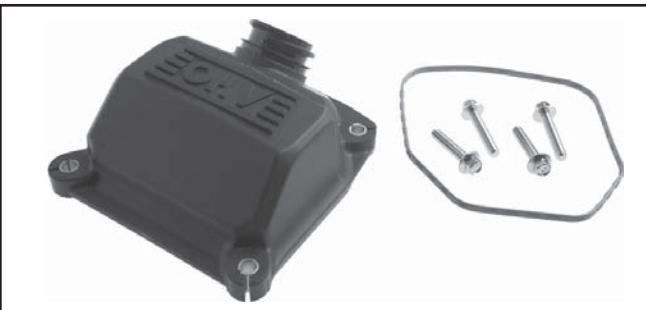

VALVE COVER WITH OIL FILL

Ideal for adding an extra oil fill location.

| Part No. | Description | Models |
|---------------|------------------------------|-----------------------------|
| 24 755 140-S* | Valve cover with oil fill** | CH18-26/730-745, ECH630-749 |
| 66 755 10-S* | Valve cover with oil fill*** | LH640-775 |

* Usable on either valve cover side, except for basic engines which include a mechanical fuel pump (with oil fill) in filter side valve cover.

** Also order 24 755 46-S yellow cap/o-ring assembly, or 25 755 13-S black cap/o-ring assembly.

***Includes yellow cap, o-ring, etc.



REMOTE OIL FILTER

| Kit No. | Oil Line Length | Models |
|--------------|-----------------|--|
| 24 702 02-S* | 23" | CH/CV11-16/460-493, SV470-610, CH/CV17-26, CH/CV730-750, SV710-740, ECH/ECV630-749 |

*Includes 12 050 01-S Filter.



OIL FILTER BASE (ENGINE-MOUNTED)

| Part No. | Position | Extends | Models |
|--------------|------------------------|---------|-----------------------|
| 24 702 01-S* | Rotatable, 6 positions | 3-4" | CH/CV17-22, LV625-680 |

* Not usable on specs with oil cooler. Includes 12 050 01-S filter.

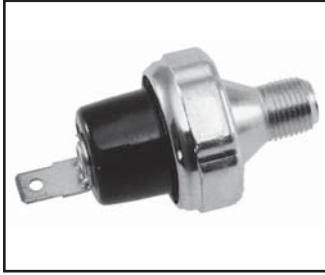

OIL PRESSURE SWITCH (OIL SENTRY™)

Available on electric start engines only.

| Part No. | Circuit | PSI To Activate | Models |
|--------------|-----------------|-----------------|--------------------------------|
| 12 704 01-S* | Normally Closed | 2-5 | CH/CV11-16/460-493 |
| 52 704 01-S* | Normally Closed | 2-5 | CH/CV17-26/730-745, LV625-680 |
| 24 099 03-S | Normally Open | 2-5 | CH/CV17-26/730-745, SV810-840 |
| 25 099 27-S | Normally Closed | 2-6 | LH640-775 (Standard on basics) |

*Kit includes switch, other components and instructions.



OIL PRESSURE BYPASS KITS

Allows for momentary bypass of oil pressure switch when electric starter is engaged.

| Part No. | Circuit | Models |
|-------------|-----------------|---|
| 82 755 25-S | Normally Closed | CH11-15*, CH/CV17-26/730-745, CH/CV940-1000, LV625-680, LH640-775, ECH/ECV630-749 |

*Usable on CH11-15, except with solenoid shift starter. Became standard on CH11-15 PRO electric start basics beginning with serial no. 3208409911.

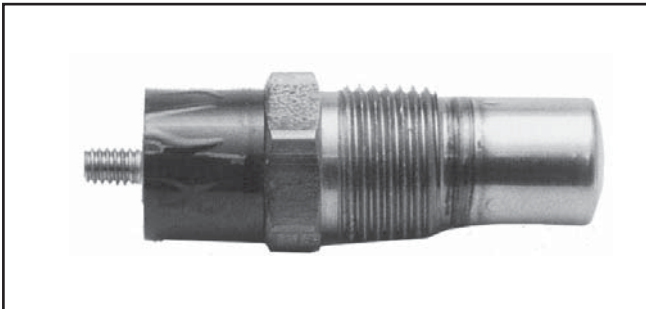

OIL TEMPERATURE SENSOR

Fits into oil drain hole to signal when temperature exceeds recommended range.

| Part No. | Open | Closed | Models |
|------------------------|-------|--------|---|
| 24 418 01-S (standard) | 310°F | 350°F | CH/CV17-26*/730-745, LV625-680, LH640-775 |
| 24 418 02-S | 255°F | 310°F | CH/CV17-26*/730-745, LV625-680, LH640-775, ECH/ECV630-749 |

*On CV specs, use on starter side only. Filter side has oil cooler.



OIL WARNING LIGHTS

| Part No. | Notes | Lead Length | Models |
|----------------|--------------------------|-------------|---------------------------------|
| 25 352 06-S | Need 15 176 03-S harness | 3" | CH5-6 |
| 25 352 10-S*** | — | 6.5", 9" | CH18-26/730-745, ECH/ECV630-749 |
| 25 352 12-S*** | — | 6.5", 9" | LH640-775 |

***Usable in panel kits. (See "CONTROL PANEL" page).

ALSO SEE PAGE 25 FOR COOLANT AND LUBRICATION ALERT ITEMS.

Starting

RECOIL START KITS

| Kit No. | Models | Notes |
|-------------|----------------------------|--|
| 12 755 47-S | CH/CV11-16/460-493 (Shown) | For metal blower housings only. |
| 25 312 01-S | | Optional mitt grip handle for recoil starter. |
| 12 165 04-S | | Recoil starter assembly with mitt grip handle. |

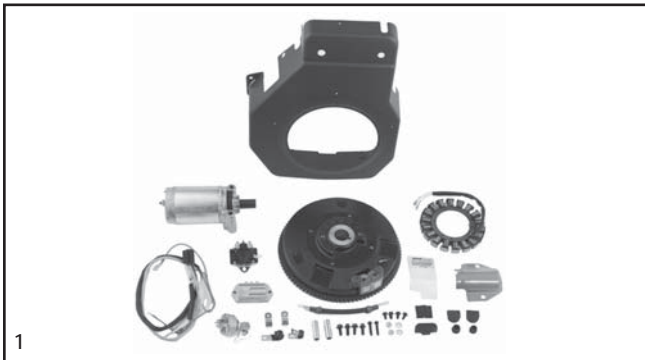
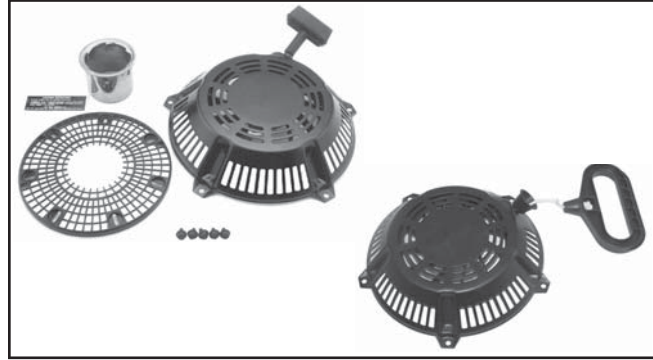

ELECTRIC START KITS

| Kit No. | Models | Items |
|------------------|---|-------|
| 12 749 02-S | CH11-15 | 1 |
| 12 749 03-S | CV11-16/460-493 | - |
| | (Excludes wire harness which customer must supply due to variations.) | |
| 17 755 03-S 110V | WH208 | 2 |

STARTER SOLENOIDS

| Part No. | Description | Models |
|-------------|---------------------|--------------------|
| 25 435 08-S | Internally grounded | CH/CV11-16/460-493 |



Meters, Testers, and Special Tools

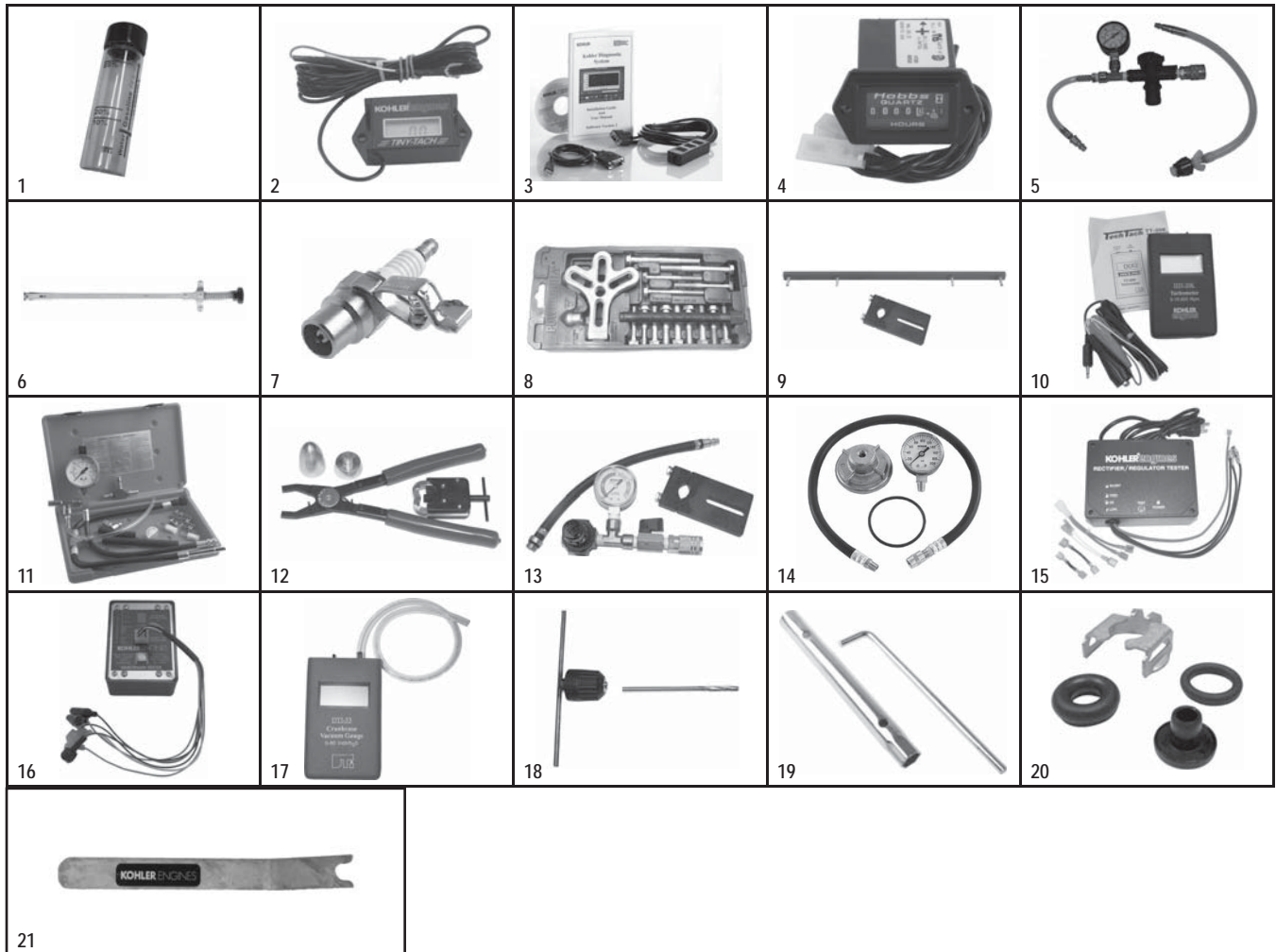

| Part No. | Description | Models | Item |
|---------------|---|-----------------------------|------|
| 25 455 11-S | Alcohol Content Tester - Tests for E10/E20/E85 | All | 1 |
| 25 449 05-S* | Usage Meter/Tachometer (solid state) | All singles & twins | 2 |
| 25 761 23-S | EFI Diagnostic Kit (includes CD-ROM to diagnose engine) | All EFI | 3 |
| 52 362 01-S | Hourmeter | All with electric start | 4 |
| 25 455 10-S** | Radiator and Cap Tester | Liquid Cooled Models | 5 |
| 25 761 38-S | Hydraulic Valve Lifter Tool | All with hydraulic lifters | 6 |
| 25 455 01-S | Ignition Output Tester (all except capacitive discharge, fires at 12kV) | All single cylinder | 7 |
| KLR-82408*** | Flywheel Puller Set | All | 8 |
| 28 761 01-S | OHC Timing Tool Set (timing belt) | All OHC | 9 |
| DTI-110** | Inductive Tachometer | All except battery ignition | 10 |
| 24 761 01-S | EFI Service Tool Kit (for individual components see Parts Bulletin 228) | All EFI | 11 |
| KLR-82411*** | Electric Starter Service Kit | All | 12 |
| 25 761 05-S | Cylinder Leakdown Tester | All | 13 |
| 25 761 06-S | Oil Pressure Test Kit | All w/pressure lubrication | 14 |
| 25 761 20-S | Rectifier/Regulator Tester (operates on 110-120 volt current) | All | 15 |
| 25 761 41-S | Rectifier/Regulator Tester (operates on 220-240 volt current) | All | 15 |
| 25 761 40-S | Spark Advance Module Tester | All w/spark advance module | 16 |
| DTI-721-01*** | Vacuum/Pressure Tester | All | 17 |
| 25 455 09-S | T-Handle for Valve Guide Reamer (below) | All | 18 |
| 25 455 12-S | 0.25mm Oversized Reamer for Valve Guides | Command and Aegis | 18 |
| 14 455 03-S | Spark Plug Tool | XT-6 and XT-7 | 19 |
| 25 755 41-S | Fuel Injector Tool Kit | ECH and ECV | 20 |
| 25 455 20-S | Hose Removal Tool | All | 21 |

* Indicates when to service air cleaner, oil filter and change oil. Also serves as an hour meter and tachometer.

Service intervals are dependent upon environmental factors and not this meter alone.

** Designed to work with item #13 (25 761 05-S) or requires a regulated air supply.

*** Available from Kohler-recommended tool supplier, see Parts Bulletin 228.

ALSO SEE PAGE 25 FOR COOLANT AND LUBRICATION ALERT ITEMS.

Special Items



1



2



3



4



5



6



7



8

OILS, SEALANTS, LUBRICANTS

| Part No. | Description | Fl. Size | For | Item |
|-------------|--|----------|----------------------|------|
| 25 357 06-S | SAE 10W-30 KOHLER® Oil | 32 oz. | All OHV/OHC Engines | 1 |
| 25 357 03-S | SAE 30 KOHLER® Oil | 32 oz. | XT-7 Engines | 2 |
| 25 357 14-S | Lubricant, Camshaft/Lifter | 0.25 oz. | — | 3 |
| 52 357 01-S | Lubricant, Inertia Drive Starter | 0.25 oz. | — | 4 |
| 52 357 02-S | Lubricant, Solenoid Shift Starter | 0.25 oz. | — | 4 |
| 25 357 12-S | Lubricant, Spline Drive | 2.8 oz. | All | 5 |
| 25 357 11-S | Grease, Dielectric | 0.25 oz. | All except EFI | 6 |
| 25 597 07-S | Sealant (Loctite Instant Gasket) | 4 oz. | All RTV Applications | 7 |
| 25 597 05-S | Sealant (Loctite 620 Retaining Compound) | 0.5 ml | — | 8 |
| 25 597 06-S | Sealant (Loctite 222 Retaining Compound) | 0.5 ml | — | 8 |

MAINTENANCE KITS

Everything needed for periodic preventative maintenance, in a handy display pack.

| Part No. | Models | Contains Air Filter |
|-------------|---|---------------------|
| 20 789 01-S | SV470-620 | 20 083 02-S |
| 12 789 01-S | CV11-15 | 12 083 05-S |
| 12 789 02-S | CV11-15, 460-493 PRO | 12 083 10-S |
| 24 789 01-S | CV17-23, 724-740; CH18-25, 730-740 | 47 083 03-S |
| 24 789 02-S | CV18-30, 675-740; CH18-25, 730-750 PRO | 24 083 03-S |
| 24 789 03-S | CV17-27, 730-740 WAWB | 45 083 02-S |
| 25 789 01-S | CV18-25, 625-750; CH18-25, 730-750 HDAC | 25 083 01-S |
| 32 789 01-S | SV710-740 | 32 083 03-S |
| 17 789 01-S | CH270 | 17 083 07-S |
| 17 789 02-S | CH395/440 | 17 083 03-S |
| 18 789 01-S | SH265 | 18 083 04-S |
| 14 789 01-S | XT | 14 083 01-S |



BAFFLE MOUNTING

| Part No. | Hardware Size |
|-------------|---------------|
| 25 154 13-S | 6 mm |



MOUNTING BOLT

| Part No. | Size |
|--------------|--|
| 25 086 130-S | 3/8-16 Thread Forming Bolt (engine mounting) |



FUEL TREATMENT

| Part No. | Fl. Size |
|-------------|----------|
| 25 357 34-S | 1 oz. |
| 25 357 35-S | 4 oz. |
| 25 357 36-S | 16 oz. |



PLASTIC NUT

| Part No. | Hardware Size |
|-------------|---------------|
| 25 100 37-S | 6mm |



DIODE KIT

| Part No. | Specifications | Models | Item |
|--------------|----------------|--------|------|
| 25 755 31-S | 6 AMP 1000PIV | All | 1 |
| 25 755 40-S* | 6 AMP 800PIV | All | 2 |

*For electric clutch spike protection

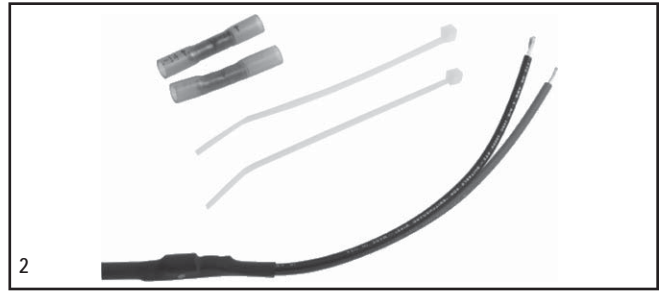

RFI/EMI CONVERSION KIT

| Kit No. | Models |
|-------------|------------------------------|
| 25 707 01-S | All CH, CV, LH, LV, SV Twins |

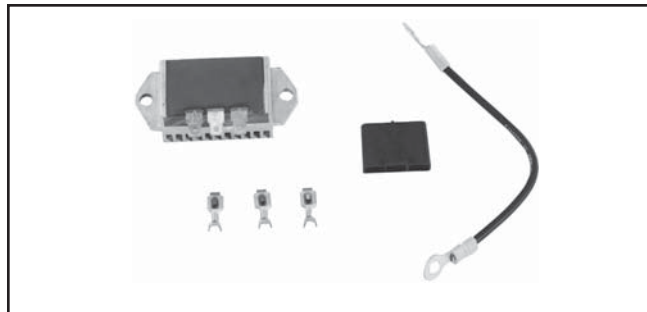

CHARGING SYSTEMS

| Part No. | Description | Models |
|------------------------------|--------------------------------|--|
| 15 Amp 237878-S | Stator Kit | CH/CV11-16/460-493, SV470-620, CH/CV17-26/730-745, LH640-775, LV625-685, SV710-740 |
| 41 403 10-S | Rectifier-Regular | All |
| 25 Amp 28 085 02-S | Stator Kit | CH/CV11-16/460-493, SV470-620 |
| 54 755 03-S | Stator/Rectifier-Regular Kit* | CH/CV17-26/730-745, TH520-575, LH640-775, LV625-675, SV710-740 |
| 24 755 144-S | Rectifier-Regular Kit**(Shown) | |

* Converts 15 amp system to 25 amp.

**Converts old 25 amp rectifier-regular (25 403 01-S or 25 403 04-S) to new 25 amp rectifier-regular (25 403 20-S) on all models. Includes rectifier-regular, terminals (3), lead, connector block.



SPARK PLUGS

| Part No. | Models |
|-------------|---|
| 66 132 01-S | LH640-775, CS4-12.75 (Champion) |
| 12 132 02-S | CH6, CH/CV11-15/460-492, CH/CV17-30/730-750, CH20-25 LP, TH520-575 LP, ECH/ECV630-749 |
| 25 132 12-S | CH/CV11-15/493 PRO, CH/CV18-30/730-750 PRO, ECH/ECV630-749 PRO |
| 25 132 08-S | CH/CV11-15 LP |
| 28 132 01-S | CH/CV17-25/730-740 R.F.I. with shielded metal boots |
| 28 132 02-S | TH520-575 R.F.I. |
| 25 132 14-S | SV470-620 R.F.I., SV710-840 R.F.I., LV625-680 R.F.I., LH640-755 R.F.I., CH/CV17-25/730-740 R.F.I. w/o metal boots |
| 62 132 04-S | CH940-1000 R.F.I. |
| 14 132 03-S | XT-7, SH265 |
| 14 132 11-S | XT-6, XT6.5, XT6.75 |

Ignition and Electrical

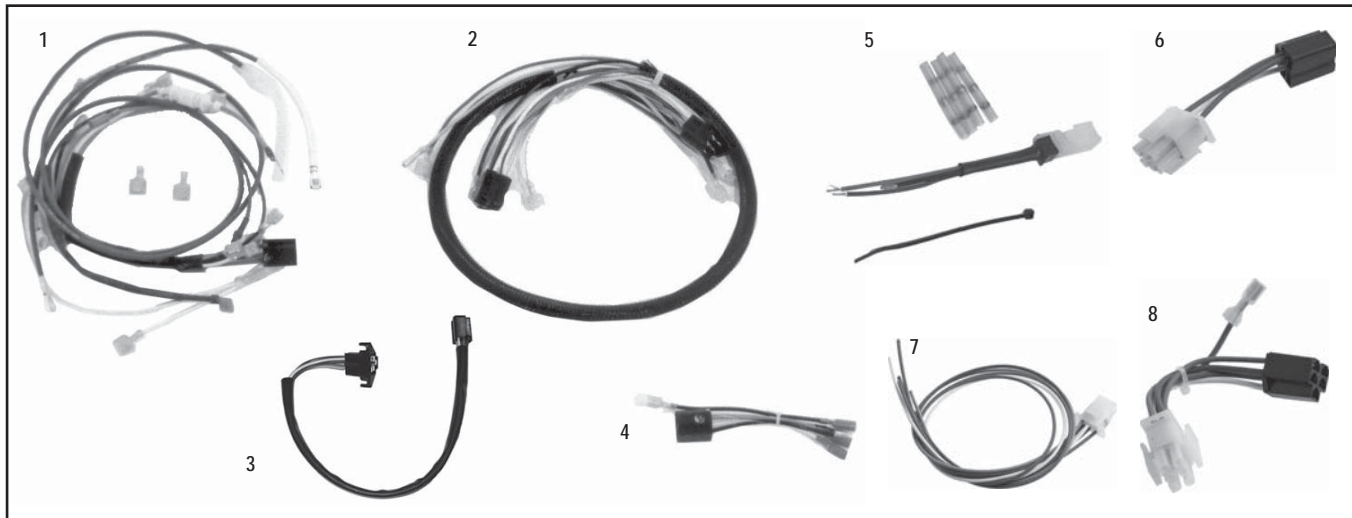

WIRING HARNESSES

| Part No. | No. Leads | Lead Length | Connector | Models | Item |
|--------------|-----------|---------------|---|--|------|
| 54 755 02-S | * | 34" longest | Numerous | CH/CV17-25/730-740 | 1 |
| 66 176 18-S | 8** | 36" longest | 25 155 06 (Female), 48 155 01 (Male) | LH640-755 | 2 |
| 52 155 08-S | 2 | 18" all | 52 155 04 (Female) | Various | 3 |
| 52 155 09-S | 3 | 18" all | 237088 (Female) | Various (shown) | 3 |
| 25 155 07-S | 5 | 18" all | 25 155 06 (Female) | Various | 3 |
| 25 155 09-S | 5 | 18" all | 25 155 06 (Female), 48 155 01 (Male) | Various | 3 |
| 25 176 02-S | 6*** | 75" longest | 25 155 06 (Female), 48 155 01 (Male) | C11-16/460-493, C17-25/730-740 LH640-755, LV625-680 | 3 |
| 25 176 10-S | 6*** | 75" longest | 25 155 06 (Female), 48 155 01 (Male) | CH/CV940-1000 | 3 |
| 63 176 01-S | 6**** | 5" longest | 48 155 01 (Male) | CS8.5-12 | 4 |
| 24 755 155-S | ***** | 4" longest | | All EFI | 5 |
| 62 176 10-S | 4 | 30" longest | Molex #33482-0401 (Male) | CH/CV940-1000 | — |
| 62 176 11-S | 4 | 3-7/8" | Molex #33482-0401 (Male), 6 Pin Packard | CH/CV940-1000 | — |
| 20 176 05-S | 3 | 3" | 6 Pin AMP, 48 155 01 (Male) | SV470-620 | 6 |
| 24 176 160-S | 5 | 24" | 6 Pin AMP | ECH/ECV630-749 | 7 |
| 24 176 165-S | 5 | 4.5" | 6 Pin 25 155 06 (Female) | ECH/ECV630-749 | 8 |
| 24 176 161-S | 4 | 7" (overall) | 4 way black Female, 4 way black Male | ECH/ECV630-749 | — |
| 24 176 197-S | 4 | 18" (overall) | 4 way black Female, 4 way black Male | ECH749 | — |

* Includes universal harness, duplex lead harness, Oil Sentry™ lead, 20 amp B+ lead, 25 amp B+ lead with Connector 25 155 03-S, (2) Terminals 15 452 10-S, and instructions.

** Can be used as a general 36" extension to basic wire harness.

*** Includes equipment ground lead for between keyswitch and engine block.

**** Used to create remote-mount keyswitch (use Keyswitch 25 099 04-S). Also order Harness 25 176 02-S above.

***** Pigtail harness used to replace diagnostic plug. Includes protective cap, 24 139 06-S.

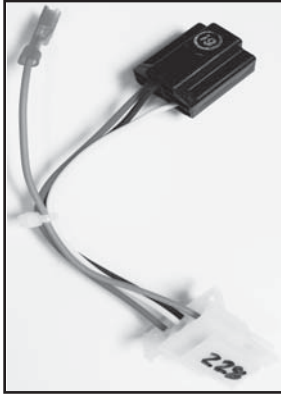
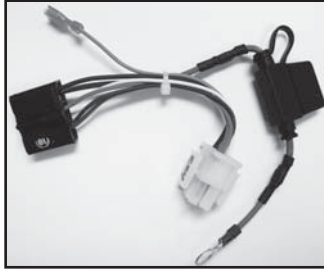
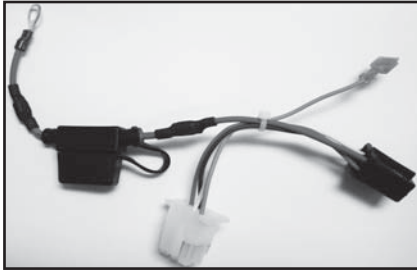

EFI JUMPER HARNESS ADAPTERS

Harness adapters have been released to make the electrical conversion when replacing a carburetor equipped Kohler engine with a Kohler Commercial EFI engine. Several of these new harness adapters are shown above. See Parts Bulletin 258 for more information.



SEALED FUSE HARNESS/HOLDER

| Part No. | Models |
|-------------|--------|
| 54 755 13-S | All |
| 25 176 14-S | |

Converts standard harness/fuse holder to a sealed version to prevent moisture, dirt, etc., from penetrating. Ideal for pressure washers or applications in corrosive environment. Includes 30 amp fuse.



FUSES

| Part No. | Description | Models |
|-------------|-------------|-----------|
| 17 304 07-S | 25 AMP Fuse | CH270-440 |
| 17 304 08-S | 15 AMP Fuse | CH270-440 |
| 17 304 04-S | 30 AMP Fuse | CH270-440 |

Ignition and Electrical

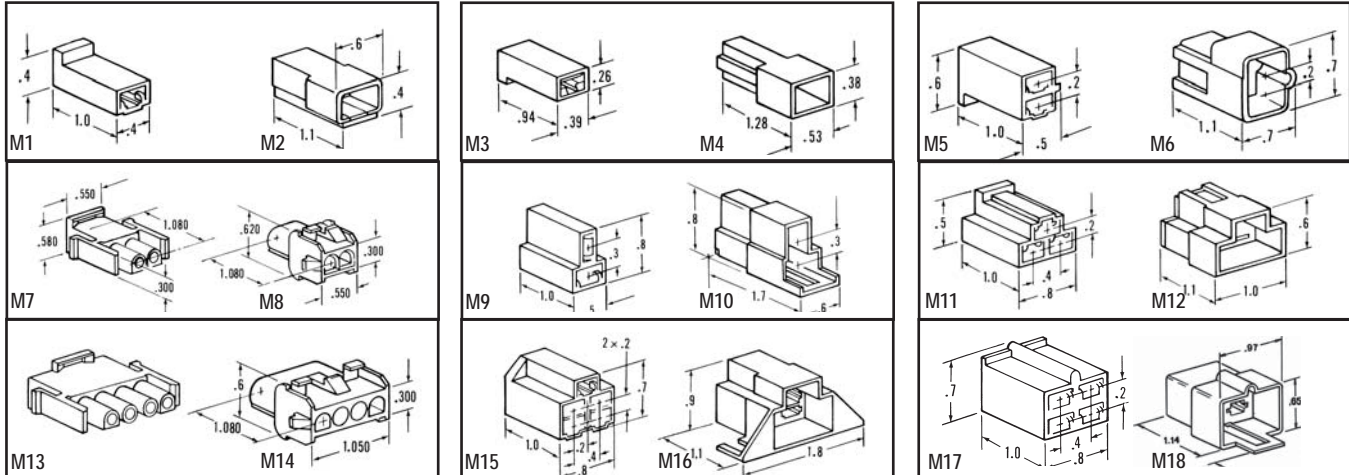

MATED (M) CONNECTORS

| Description | Connector Item | Connector Part No. | Uses Female Terminal (See Below) | Connector Item | Connector Part No. | Uses Male Terminal (See Below) |
|-------------|----------------|--------------------|----------------------------------|----------------|--------------------|--------------------------------|
| 1 Wire | M1 | 277563-S | Item 5, 6 | M2 | 15 155 01-S | Item 4 |
| 1 Wire | M3 | 25 155 04-S | Item 5, 6 | M4 | 25 155 03-S | — |
| 2 Wire | M5 | 41 155 03-S | Item 5, 6 | M6 | 52 155 04-S | Item 4 |
| 2 Wire | M7 | 47 155 14-S | — | M8 | 47 155 13-S | — |
| 2 Wire | M9 | 48 155 02-S | Item 5, 6 | M10 | 48 155 03-S | Item 4 |
| 3 Wire | M11 | 236473-S | Item 5, 6 | M12 | 237088-S | Item 4 |
| 4 Wire | M13 | 12 155 03-S | — | M14 | 12 155 02-S | — |
| 5 Wire | M15 | 48 155 01-S | Item 5, 6 | M16* | 25 155 06-S | Item 4 |
| 4 Wire | M17 | 41 155 02-S | Item 5, 6 | M18 | 12 155 10-S | Item 4 |

*Mounting screw slots on M16 are 1.328" center to center.

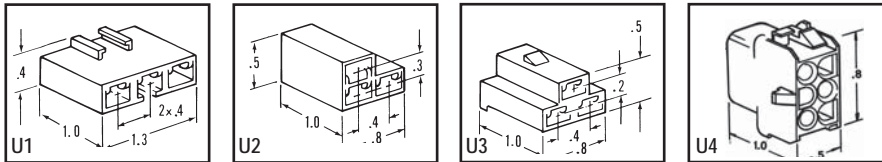

UNMATED (U) CONNECTORS

| Description | Connector Part No. | Connector Item | Uses Terminal (See Below) |
|-------------|--------------------|----------------|---------------------------|
| 3 Wire | 25 155 41-S | U1 | Item 5, 6 |
| 3 Wire | 237429-S | U2 | Item 5, 6 |
| 3 Wire | 52 155 06-S | U3 | Item 5, 6 |
| 6 Wire | 12 155 09-S | U4 | Item 11 |

TERMINALS

| Size | Part No. | Type | Code | Item |
|------------|-------------|--------|--------|------|
| 3/16" Flat | 25 452 11-S | F.I.F. | S | 1 |
| 3/16" Flat | 25 452 12-S | F.I.F. | F | 2 |
| 1/4" Flat | 25 452 07-S | F.I.F. | S | 1 |
| 1/4" Flat | 15 452 01-S | F.I.M. | S | 3 |
| 1/4" Flat | 52 452 01-S | L.M. | S, U | 4 |
| 1/4" Flat | 25 452 01-S | L.F. | S, U | 5 |
| 1/4" Flat | 25 452 06-S | L.F. | S, U | 6 |
| 1/4" Flat | 12 452 02-S | M | 45°, U | 7 |
| 1/8" Round | 25 452 17-S | F.I.M. | S | 8 |
| 12-10 AWG | 25 155 45-S | B | — | 9 |
| 16-14 AWG | 25 155 47-S | B | — | 9 |
| 20-14 AWG | 25 452 25-S | L.M. | S, U | 10 |
| 20-14 AWG | 25 452 26-S | L.F. | S, U | 11 |

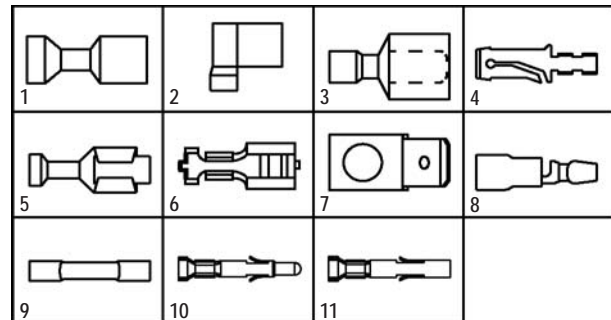

Type
 F.I.F. = Fully Insulated Female
 F.I.M. = Fully Insulated Male
 L.F. = Locking Female
 L.M. = Locking Male
 M = Male
 B = Butt Splice Connector (heat shrinkable)

Code
 S = Straight push on tab
 F = Flag push on tab
 U = Uninsulated

Guards, Screens, and Blower Housings

METAL CHOPPER GRASS SCREEN KITS

Kit No. 24 755 79-S Models CH/CV17-26/730-745, ECH/ECV630-749

Replaces plastic screen, or can replace "crowned" metal screen on engines below Serial No. 2528418567. A new blower housing is required if replacing a plastic screen.*

Note: When installing metal screen on an "open" application, guard kit 24 755 94-S is required.

*Due to blower housing variations, consult Kohler factory. Based on the spec number of your engine, the corresponding blower housing can be determined.

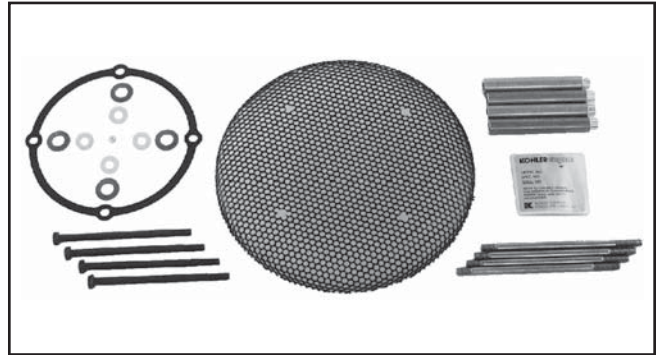

Kit No. 62 162 08-S Metal Grass Screen

Models CH940-1000

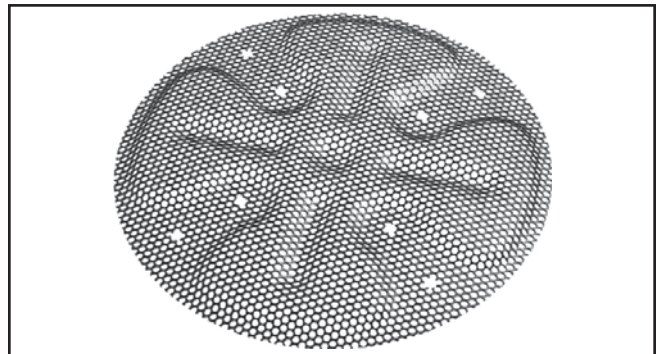

MANIFOLD COVER KITS

| Kit No. | Model | Item |
|--------------|----------------------------------|------|
| 24 096 110-S | CH750 | 1 |
| 24 096 111-S | CH750 (w/front mounted controls) | 2 |

Covers hide exposed portion of intake manifold.

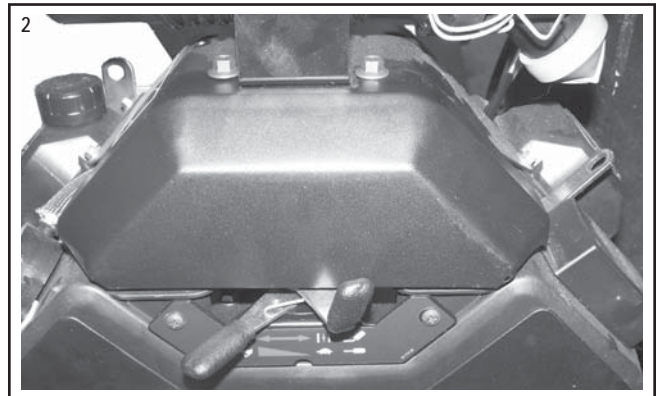
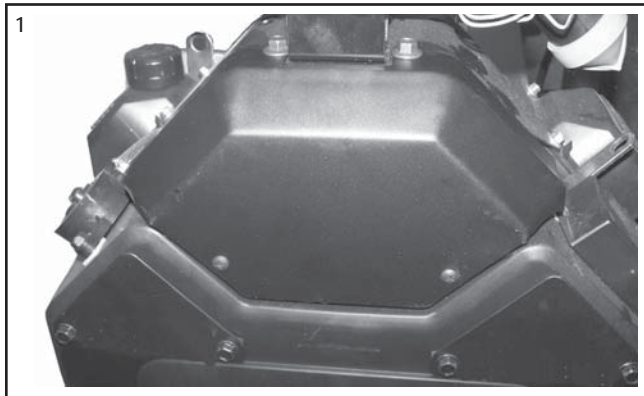

DEBRIS SCREEN

Kit No. 14 332 19-S Model XT

Note: Will only fit on fixed position recoil models.

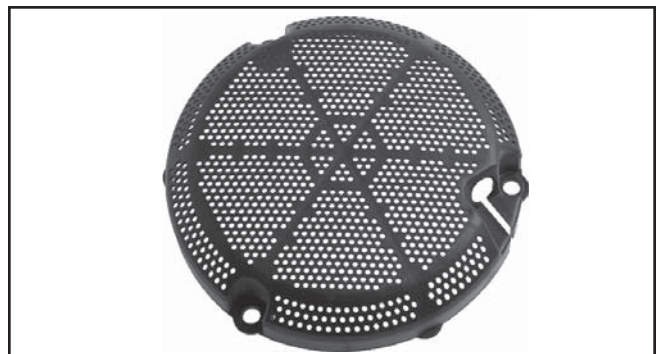

Guards, Screens, and Blower Housings

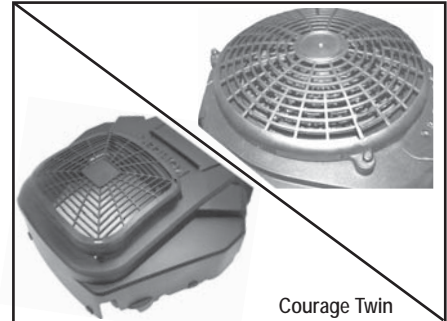
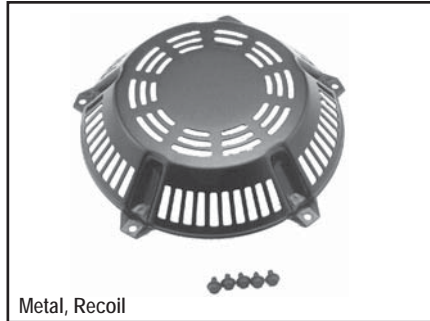
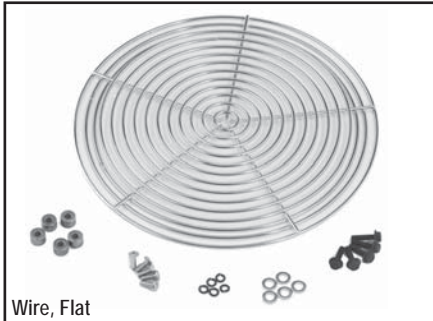
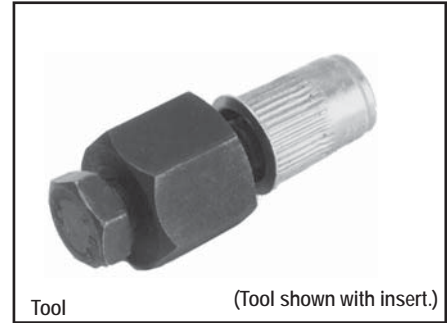
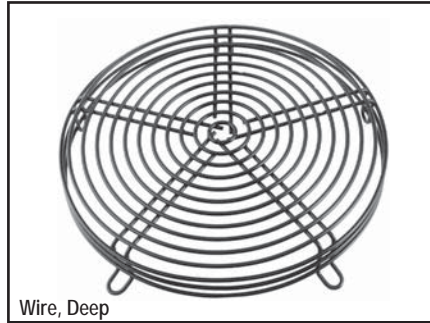
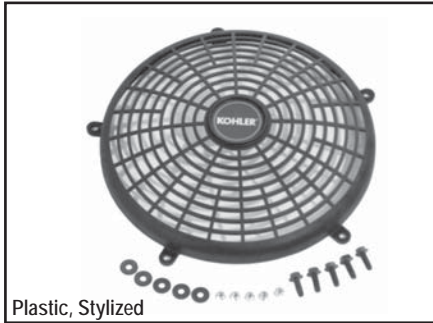

FIXED GUARDS (NOT USABLE WITH RECOIL STARTER)

| Models | Plastic, Stylized | Wire, Deep | Tool | Wire, Flat | Metal, Recoil |
|--------------------|--------------------------|-----------------|-------------|---------------------|---------------|
| CS8.5-12.75 | — | — | — | 63 755 17-S | — |
| CH/CV11-16/460-493 | 12 755 65-S (Shown) | — | — | 12 755 44-S (Shown) | 12 755 48-S |
| SV470-620 | 20 755 11-S, 20 755 14** | — | — | — | — |
| CH/CV17-26/730-750 | 24 755 81-S* | 24 755 94-S* | 24 455 01-S | — | — |
| SV710-740 | 32 027 08-S*** | — | — | — | — |
| ECV940 & ECV980 | — | 62 755 33-S**** | — | — | — |

* Guard kits 24 755 81-S and 24 755 94-S include threaded inserts (24 332 01-S). Insert tool (24 455 01-S) is not included but needed to attach guard to existing blower housing. Tool is reusable. If engine has a metal grass screen, then only guard kit 24 755 94-S should be used. In addition, guard 24 755 94-S is required in open applications (mowers, etc.) to protect the metal screen from potential damage.

** If original blower housing has the three bosses with holes for fixed guard mounting use 20 755 14-S kit. If original blower housing does not have the three bosses with holes, use 20 755 1-S blower housing and guard kit.

*** For guard only, order 32 314 05-S.

**** For guard only, order 62 314 14-S.

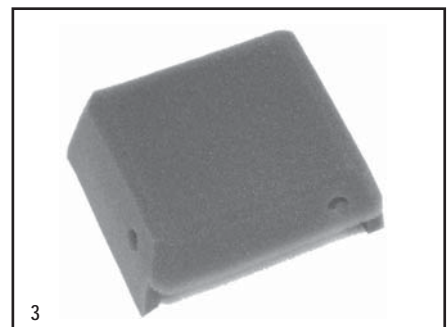
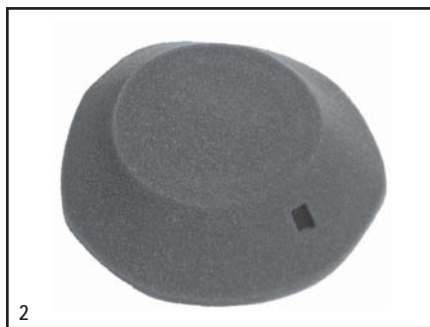

RECOIL STARTER FILTERS

Help prevent dust, dirt and debris from entering around recoil starter.

| Part No. | Notes |
|---------------|--|
| 63 755 18-S | Includes handle hole, Velcro, maintenance label and instructions. |
| 12 050 02-S* | Includes handle hole. Conforms to shape of recoil housing when using fasteners*. |
| 15 050 01-S** | Includes handle hole. |

* For first-time usage, also order (10) 12 290 01-S Velstuds for holding the filter in place. Velstuds are reusable; they interlock with slots in starter housing.

** Also order 63 290 01-S Velcro strip (4.75" long). Cut into pieces for attachment of filter to starter housing.

| Models | Item |
|-----------------|------|
| CS4-6 | 1 |
| CV11-16/460-493 | 2 |
| CH6 | 3 |

Guards, Screens, and Blower Housings

BLOWER HOUSING CLEAN OUT PANELS

| Kit No. | Description | Models |
|-------------|-----------------------|--------------------------------------|
| 25 755 20-S | Matte Black Panel (2) | CH/CV17-26/730-750 ECH/ECV630-749 |

Allows for cleaning debris from behind blower housing and also servicing of ignition modules. Kit includes instructions/template for cutting holes in blower housing, plus panels (one with pop-out plug and label for keyswitch), mounting clips and screws. (Blower housing not included.)



BLOWER HOUSING PLUGS

| Part No. | Description | Models |
|----------------|------------------------------|---------------------------------------|
| 24 096 17-S* | Triangular Plug (1) (Shown) | CH/CV17-26/730-750, ECH/ECV630-749 |
| 24 096 119-S** | Triangular Plug With Lip (1) | CV17-26/730-750 ECV630-749 |

* Seals the triangular hole in the blower housing underneath the air cleaner. Two required for CH twins, one for CV twins.

** Similar to 24 096 17-S, but has an extended rubber lip. Seals the triangular hole (under the air cleaner) through which the breather hose is routed. One required.



DUCTED AIR KIT

| Kit No. | Description | Models |
|-------------|----------------|-----------------|
| 24 755 14-S | Ducted Air Kit | CH18-26/620-750 |

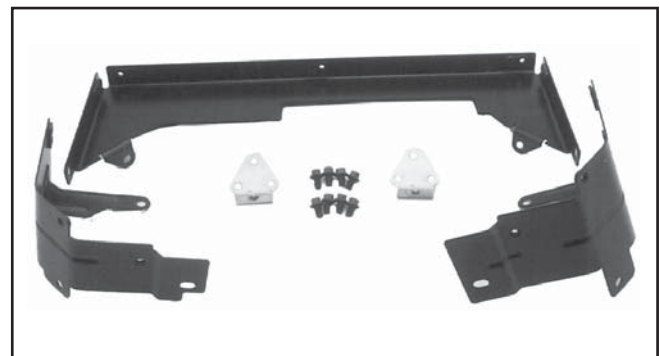

Front Drive Shafts

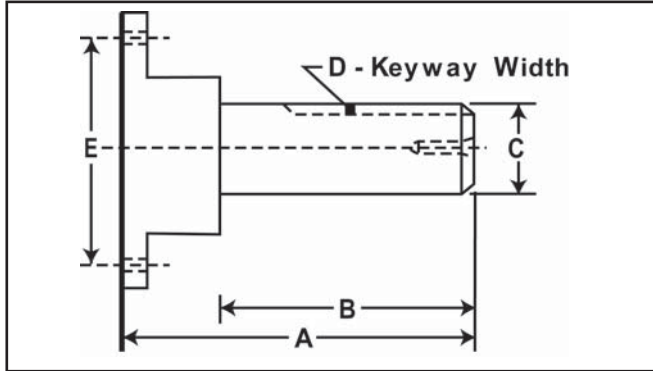

FRONT DRIVES (DIMENSIONS IN INCHES)

| Part No. | A | B | C | D | E | Hardware Required | D & T | Models* |
|-------------|------|------|-------|--------|-----|-------------------|------------|--|
| 52 144 19-S | 4.66 | 2.53 | 1.0 | .25 | 3.0 | See Below | 3/8-16 | CH11-15, LH640-775 |
| 235954-S | 3.48 | 1.44 | 1.0 | .25 | 3.0 | See Below | 3/8-16 | CH11-15, LH640-775 |
| 237350-S | 4.66 | 2.41 | 1.125 | — | 3.0 | See Below | — | CH11-15, LH640-775 |
| 47 144 09-S | 3.88 | 1.75 | 1.0 | .25 | 3.0 | See Below | 7/16-20 | CH11-15, LH640-775 |
| 52 144 07-S | 3.80 | 1.80 | 1.0 | .25WD | 3.0 | See Below | — | CH11-15, LH640-775 |
| 24 755 05-S | 7.00 | 1.44 | 1.0 | .25 | 3.0 | See Below | 3/8-16 | CH18-26/730-750, LH640-775, ECH630-749 |
| 24 755 06-S | 7.00 | 1.76 | 1.0 | .25 | 3.0 | See Below | 7/16-20 | CH18-26/730-750, LH640-775, ECH630-749 |
| 24 755 07-S | 7.00 | 1.80 | 1.0 | .25 | 3.0 | See Below | — | CH18-26/730-750, LH640-775, ECH630-749 |
| 24 755 08-S | 7.00 | 2.53 | 1.0 | .25 | 3.0 | See Below | 3/8-16 | CH18-26/730-750, LH640-775, ECH630-749 |
| 24 144 13-S | 6.40 | 2.53 | 1.0 | .25 | 3.0 | See Below | 3/8-16 | CH18-26/730-750, LH640-775, ECH630-749 |
| 24 144 16-S | 5.35 | 2.53 | 1.0 | .25 | 3.0 | See Below | — | CH18-26/730-750, LH640-775, ECH630-749 |
| 24 144 17-S | 4.00 | 1.93 | 0.7** | .188WD | 3.0 | See Below | — | CH18-26/730-750, LH640-775, ECH630-749 |
| 24 144 22-S | 6.20 | 2.60 | 1.125 | .25 | 3.0 | See Below | — | CH18-26/730-750, LH640-775, ECH630-749 |
| 24 144 23-S | 4.84 | 2.82 | 1.0 | .25 | 3.0 | See Below | 3/8-16 | CH18-26/730-750, LH640-775, ECH630-749 |
| 24 144 25-S | 5.51 | 2.17 | 1.0 | .25 | 3.0 | See Below | — | CH18-26/730-750, LH640-775, ECH630-749 |
| 24 144 32-S | 8.23 | 3.79 | 1.0 | .25 | 3.0 | See Below | M12 x 1.75 | CH18-26/730-750, LH640-775, ECH630-749 |
| 24 144 47-S | 4.50 | 1.50 | 1.125 | .25 | 3.0 | See Below | 7/16-20 | CH18-26/730-750, LH640-775, ECH630-749 |
| 24 144 51-S | 5.98 | 2.36 | 1.0 | .25 | 3.0 | See Below | 7/16-20 | CH18-26/730-750, LH640-775, ECH630-749 |
| 24 144 53-S | 4.00 | 1.36 | 1.0 | .25 | 3.0 | See Below | 3/8-16 | CH18-26/730-750, LH640-775, ECH630-749 |
| 28 144 05-S | 5.28 | 3.07 | 1.125 | .25 | 3.0 | See Below | — | CH18-26/730-750, LH640-775, ECH630-749 |
| 66 144 04-S | 3.87 | 2.37 | 1.125 | .25 | 3.0 | See Below | — | CH18-26/730-750, LH640-775, ECH630-749 |
| 62 144 07-S | 4.54 | 2.30 | 1.125 | .25 | 3.0 | See Below | 7/16-20 | CH940-1000 |
| 62 144 09-S | 5.33 | 2.00 | 1.125 | .25 | 3.0 | See Below | 7/16-20 | CH940-1000 |
| 24 144 55-S | 4.50 | 1.50 | 1.0 | .25 | 3.0 | See Below | 3/8-16 | CH18-26/730-750, ECH630-749 |

* Consult factory on: CH11-15 since flywheel holes may vary and spec may not accept front drive: LH640-775 to verify front loading.

** Threaded end (3/4"-16 UNF-2A).

WD = Woodruff Key

Required Hardware:

CH11-15: (2) X-22-2-S Washer, (2) M10x30mm-1.5 socket head screw purchased locally

CH18-26/730-750: (4) M-839025-S Screw (Included in -755 kits)

LH640-775: (4) M-839025-S Screw

CH940-1000: (4) M-839035-S Screw

SOME FRONT DRIVES REQUIRE:

LH640-775: Also order 66 096 18-S Flywheel Cover w/ hole for front drive or instruction sheet TT-5081 for a template to cut the hole in your existing flywheel cover.

All other models: Also order Grass Screen w/hole for front drive per table below. If changing from plastic screen to metal screen, also order blower housing. Contact customer service at factory for correct blower housing.

| Grass Screen Part No. | Type | Hole Dia. (In.) | Hardware Required To Attach New Screen | Models |
|-----------------------|------------------|-----------------|--|-----------------|
| 12 162 03-S | Plastic | 2.56 | None | CH11-15 |
| 24 755 171-S | Plastic | 1.42 | (4) M-639016-S Screw, (4) 12 112 01-S Spacer | CH18-22 |
| 24 162 34-S | Plastic, Hi-Eff. | 1.77 | None | CH18-26/730-750 |
| 24 162 38-S | Metal*, Flat | 1.57 | None* | CH18-26/730-750 |
| 24 162 39-S | Metal*, Flat | 2.95 | None* | CH18-26/730-750 |
| 24 162 40-S | Metal*, Flat | 2.46 | None* | CH18-26/730-750 |
| 62 162 09-S | Metal | 1.81 | None | CH940-1000 |

*Flat design. If replacing older "crowned" version, also order 54 755 10-S Hardware Kit.

CRANKSHAFT SPLINE INSERT KIT

Kit No.
82 755 02-S
25 755 27-S
48 755 21-S

Number of Teeth
9
11
13

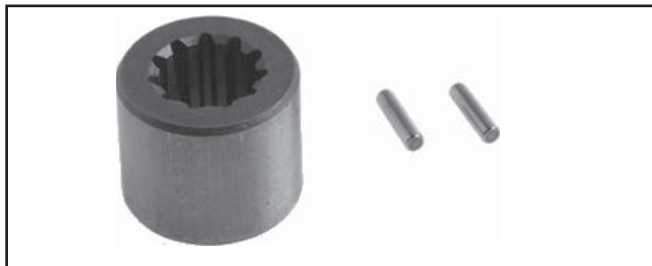

CRANKSHAFT PTO KEY

Part No.
25 340 05-S
25 340 06-S

Description
Fits 3/16" keyway
Fits 1/4" keyway

Models
CS4, CS6, CH270, SH265
CH395, CH440, CS8.5, CS10, CS12

Fuel

FUEL FILTERS

| Part No. | Inlet Hose | | Shell Length | Models |
|-------------|-------------|--------|--------------|---|
| | I.D. | Micron | | |
| 25 050 21-S | 1/4" | 75 | 2.13" | Standard: CH/CV11-15/493 |
| 24 050 13-S | 9/32", 1/4" | 9-12 | 2.35" | Standard: CH/CV17-25/730-740, 750, 940-1000, LV625-680, LH640-755, SV470-620, SV710-840 |
| 24 050 03-S | 5/16" | 8-10 | 5.51" | Standard: All EFI (metal, high pressure, extended life filter) |
| 24 050 12-S | 3/8" | 80 | 5.51" | Standard: All EFI (plastic, low pressure, between fuel tank and fuel pump) |
| 25 050 07-S | 3/16, 1/4" | 75 | 1.0" | Standard: XT-7, CH/CV11-16/460-492 non-PRO (electric start) |
| 25 050 22-S | 1/4" | 51 | 2.13" | Standard: CH/CV11-15/493 (fuel pump fed fuel) |
| 25 050 42-S | 5/16" | 10 | 1.56" | Standard: ECH630-749/ECV630-749 |
| 14 050 14-S | 1/4" | 110 | 2.40" | Standard: XT, WH208 (in-nipple filter) |
| 17 050 17-S | 1/4" | 60 | 1.60" | Standard: CH270-440 |

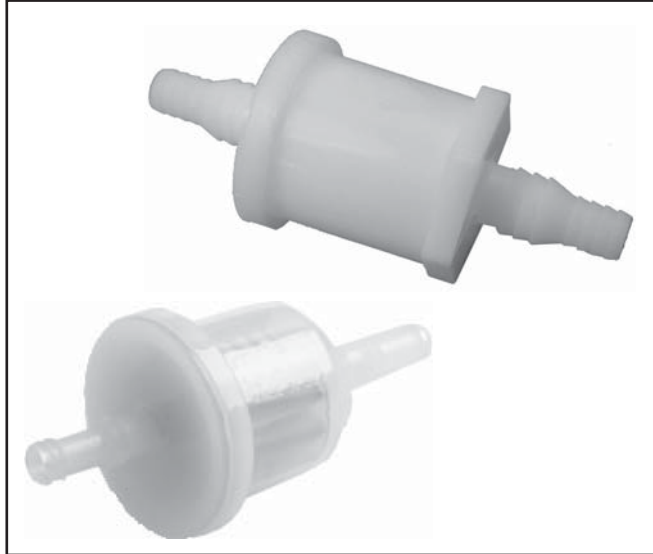

LOW PERMEATION FUEL LINE

| Part No. | I.D. | Length | Model |
|-------------|-------|-----------------|----------------|
| 25 111 81-S | 1/4" | 39" | All except EFI |
| 25 111 39-S | 1/4" | 25' (bulk roll) | All except EFI |
| 25 111 37-S | 5/16" | 5' | EFI Only |
| 25 111 69-S | 1/4" | 11" | XT |

ALCOHOL CONTENT TESTER

Part No. - Tests for E10/E20/E85
25 455 11-S



INLINE FUEL SHUT-OFF VALVE

Part No. - Fits all 1/4" fuel lines
17 099 25-S



FUEL TANK KIT

| Kit No. | Tank Mounting | Tank Material | Tank Capacity (Gal.) | Includes Cap | Models |
|-------------|---------------|---------------|----------------------|--------------|---------|
| 12 760 01-S | Engine | Plastic | 1.25 | 25 173 08-S | CH11-15 |



FUEL TANK CAPS

| Item | Part No. | Gauge in Cap | Fits |
|------|-------------|--------------|---|
| 1 | 25 173 04-S | Yes | Voided 52 755 45 remote metal tank |
| 1 | 25 173 21-S | Yes | Voided 52 755 79 remote plastic tank |
| 2 | 25 173 22-S | No | 25 755 35 remote plastic tank |
| 3 | 25 173 20-S | No | CH11-15 |
| 4 | 14 227 11-S | No | XT-7 |
| 5 | 14 227 16-S | No | XT-6/7 |
| 6 | 17 173 25-S | No | CH270-440, SH265 |
| 7 | 17 173 19-S | No | CH270-440, SH265 (evaporative emission version) |

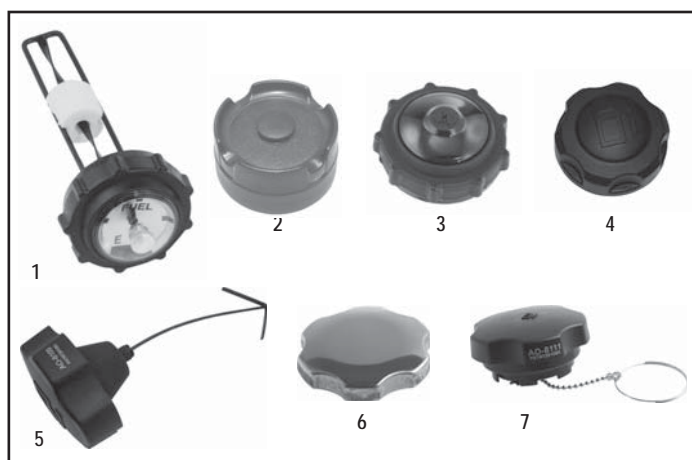

CARBON CANISTER KIT

| Kit No. | Description | Quantity | Item |
|------------------|--------------------------------|----------|------|
| 25 755 38-S | Carbon Canister Kit (5 gallon) | 1 | — |
| INCLUDES: | | | |
| 14 237 05-S | Hose Clamp | 2 | 1 |
| 25 050 39-S | Carbon Canister Filter | 1 | 2 |
| 25 237 24-S | Hose Clamp | 4 | 3 |
| 25 313 04-S | Roll-over Valve Grommet | 1 | 4 |
| 25 326 08-S | SAI Control Hose | 1 | 5 |
| 25 462 17-S | Roll-over Valve | 1 | 6 |
| 25 326 23-S | Evaporative Hose | 1 | 7 |

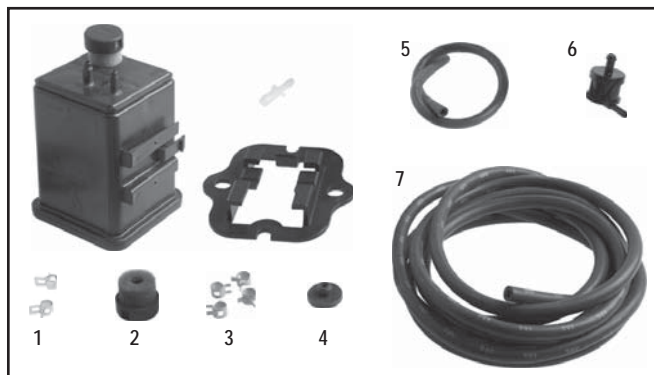

Fuel

ELECTRIC FUEL PUMP

| Kit No. | Models | P.S.I. at 0 Delivery | Self-Prime Lift | Total Column |
|-------------|---------------------------|----------------------|-----------------|--------------|
| 25 559 01-S | All except CH6, CS, & EFI | 0.5-2.0 | 12" | 6' |

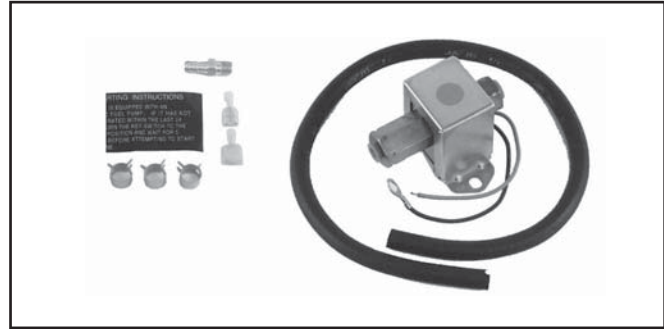

EFI ELECTRIC FUEL PUMP - HIGH PRESSURE

| Part No | Models | P.S.I | G.P.H. | AMPS Max |
|-------------|---------|-------|--------|----------|
| 24 393 52-S | All EFI | 50 | 15.0 | 5.0 |



PULSE FUEL PUMP

| Part No. | Models | Item |
|-------------|--|------|
| 24 393 16-S | CH/CV17-25/730-740, LV625-675, ECH/ECV630-749, SV470-840 | 1 |



MECHANICAL FUEL PUMPS

| Part No. (Non-Metallic) | Models | Item |
|-------------------------|--------------------|------|
| 12 559 02-S | CH/CV11-16/460-493 | 1 |
| 24 559 10-S* | CH18-25/730-740 | 2 |
| 62 559 01-S*** | CH940-1000 | 3 |

* Integral valve cover. For #2 cylinder side (oil filter side) only. For engines below Serial No. 2520800017, also order Valve Train Kit 24 755 66-S to convert to compatible rocker arms.

** Fittings include O-ring 25 153 03-S.

*** Integral valve cover. For #2 cylinder side (oil filter side) only.

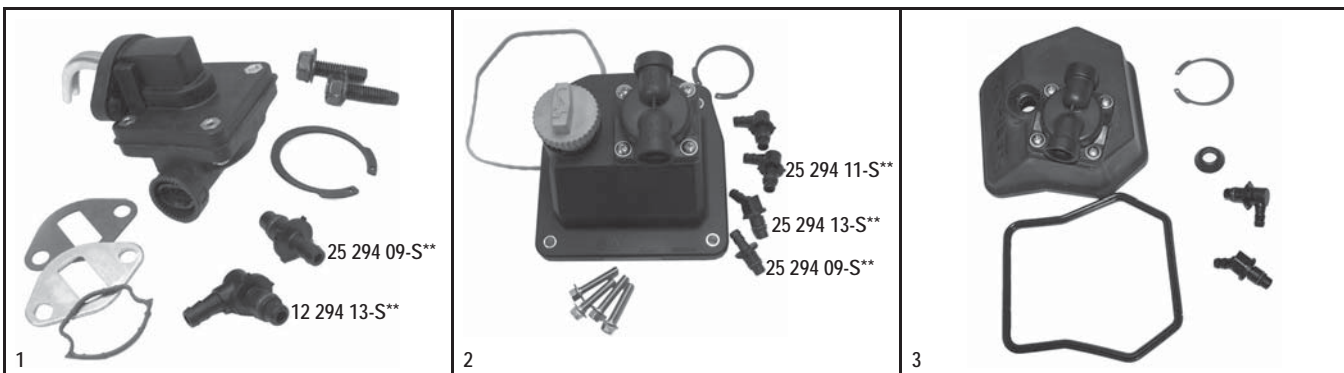

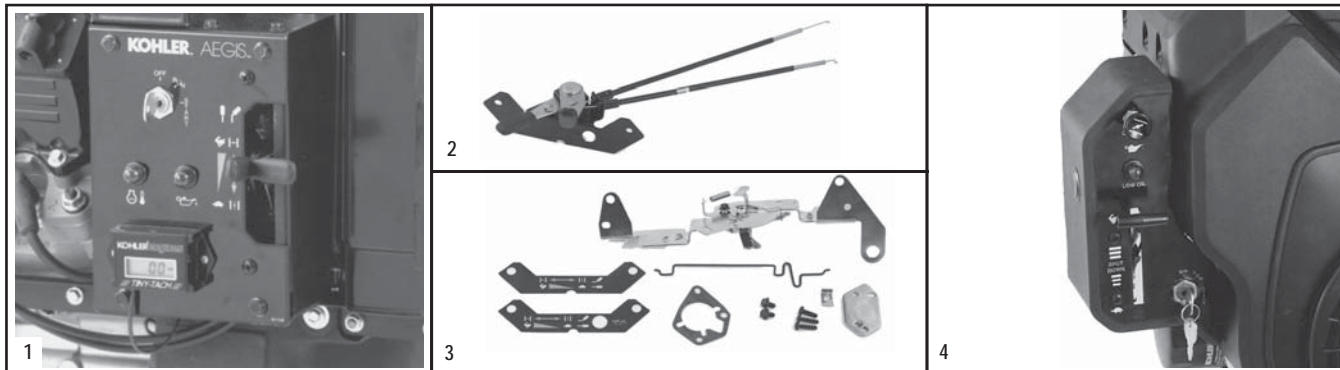

ENGINE-MOUNTED CONTROL PANELS

| Kit No. | Mounting Location | Major Components | Models | Item |
|----------------|--------------------|--|-----------------|------|
| 66 755 09-S* | Filter Side (only) | Panel, keyswitch, choke, throttle, low oil light, harness | LH640-755 | 1 |
| 24 225 02-S** | Front Side | Bracket, levers, cable assembly | CH18-26/730-745 | 2 |
| 24 755 106-S** | Front Side | Panel, choke, throttle (includes item 2) | CH18-26/730-745 | 3 |
| 24 711 01-S*** | Filter Side | Panel, keyswitch, choke, throttle, low oil light, harness | CH18-26/730-740 | 4 |
| 62 376 02-S | Front Side | Panel, keyswitch, indicator light, choke/throttle brackets | CH940-1000 | — |

* Shown with optional additional items: Coolant Temp Gauge and Coolant Temp Light (only one may be used), and Tiny Tach/Hourmeter.

** For installation of lever-type throttle/choke which became standard since Serial No. 3009400011. Also order Air Cleaner Cover 24 096 26-S if adding controls to non-panel engine spec. Also needs Bracket 24 126 99-S (1), Screw M-545010-S (2), Decal 24 113 92-S, and Screw 24 086 06-S (2)

*** Will not work with radiator-style oil cooler or on same side as side-mounted muffler.

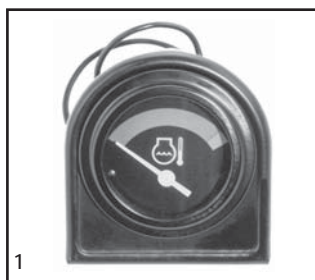

COOLANT ITEMS

| Kit No. | Description | Models | Item |
|----------------|----------------------------|-----------|------|
| 66 755 11-S** | Gauge, Coolant Temperature | LH640-775 | 1 |
| 66 755 12-S*** | Light, Coolant Temperature | LH640-775 | 2 |

** Includes gauge & holder for mounting atop control panel shown above, temp. sensor, harness.

*** Includes light/wiring, temp. switch.

Note: Coolant gauges show green band for safe temp., red band for hot.



LUBRICATION ITEMS

| Kit No. | Description | Models |
|---------------|--------------------|-----------------|
| 25 352 10-S** | Light, Oil Warning | CH18-26/730-745 |
| 25 352 12-S** | Light, Oil Warning | LH640-775 |

** Includes light, 6.5" & 9" leads, fits in control panels shown above.

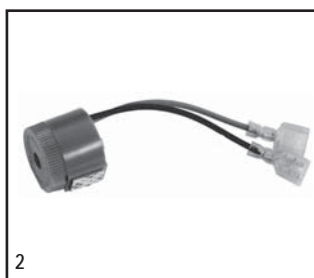

THERMOSTAT

Gasket included.

| Kit No. | Description | Models | Item |
|-------------|------------------|----------------------|------|
| 66 453 02-S | 190°F Thermostat | LV625-680, LH640-775 | 1 |
| 66 453 03-S | 205°F Thermostat | LV625-680, LH640-775 | 1 |

HORN ALERT KIT

Includes alarm, coolant temp. switch, harness. Already std. on LV.

| Kit No. | Description | Models | Item |
|-------------|-----------------|----------------------|------|
| 66 755 05-S | Horn Alert Kit* | LV625-680, LH640-775 | 2 |

* Provides audible alarm in conjunction with or in place of light or gauge.

CAUTION (ALL WARNING DEVICES ON THIS PAGE):

1. If overheating occurs, remove load, run engine at high speed to create air flow for cooling engine.
2. If low oil level/pressure occurs, stop engine immediately.

Controls

TAMPER-RESISTANT CONTROL KITS

Prevents tampering with high-speed adjustment (as proposed by European regulations).

| Kit No. | For Models | When Models Are Equipped With | Note |
|-------------|-----------------|-------------------------------|------|
| 24 755 97-S | CV18-26/730-745 | Top Controls | C |

A — Includes cover and (2) TORX screws for attachment to control bracket. Instructions are included to add holes to the bracket if there are none.

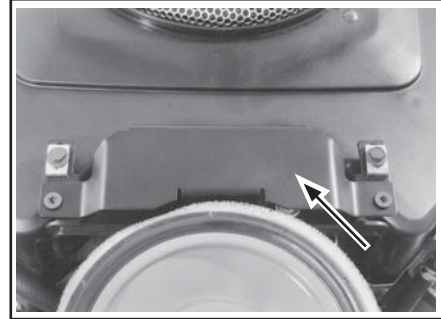

KEY SWITCH & KEYS

| Part No. | Description Models | Item |
|-------------|---|------|
| 25 099 32-S | Switch (5 pin) & Key Magneto | 1 |
| 25 099 29-S | Switch (5 pin) & Key CH940-1000 | 1 |
| 52 099 02-S | Switch (3 pin) & Key EFI | 1 |
| 25 099 30-S | Switch (5 pin) & Key CH640-750, CV17-26, CV624-750 | 2 |
| 17 340 11-S | CH270-440 Keys | 4 |
| 18 340 02-S | WH208 Key | 5 |
| 48 340 01-S | Keys (fits items 1 & 2) | 3 |

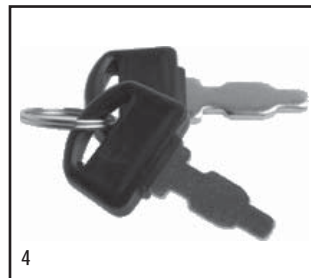
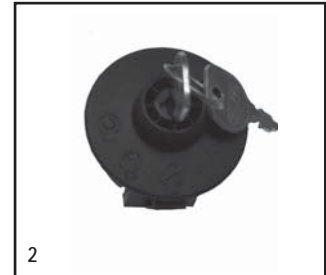

KEY SWITCH PLUGS

| Part No. | Description | Item |
|-------------|--|------|
| 25 139 16-S | Round plastic plug (fits 25 139 76-S plug) | 1 |
| 25 139 17-S | Round plastic plug (fits 1/2" key switch hole) | 2 |
| 25 139 76-S | Plastic key switch plug | 3 |



IDLE DOWN SOLENOID KITS

| Part No. | Description |
|-------------|---|
| 17 755 29-S | CH270 Idle down solenoid (w/o key box) |
| 17 755 30-S | CH270 Idle down solenoid (w/key box) |
| 17 755 31-S | CH395 Idle down solenoid (w/o key box) |
| 17 755 32-S | CH395 Idle down solenoid (w/key box) |
| 17 755 35-S | Required to provide packaged component for the servicing of CH440 engines with fixed speed and without a Kohler-supplied fuel tank. |

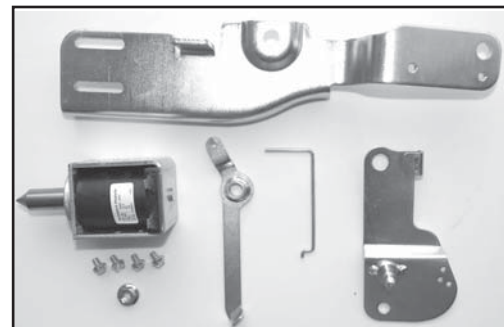

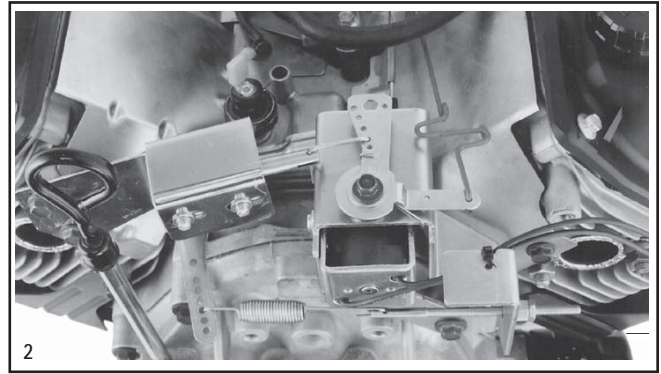
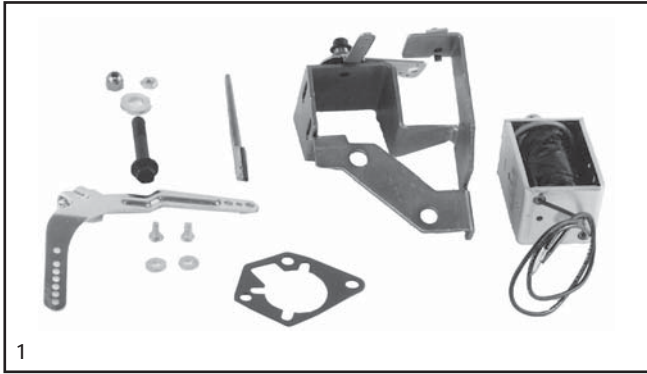

SOLENOID-OPERATED CONTROLS (12 DC VOLTS)

| Kit No. | Description | For Engines With | Models | Item |
|--------------|----------------------|------------------|-------------------------------|------|
| 24 755 100-S | Idle Kit* | Constant Speed | CH18-25/730-740, LH640-755*** | 1 |
| 24 755 101-S | Throttle/Choke Kit** | Constant Speed | CH18-25/730-740, LH640-755*** | 2 |

* When voltage is applied to solenoid, engine speed is "low idle." When voltage is removed, engine speed is "high idle."
 ** Allows start-up to constant high speed from remote equipment (lift platform, etc.).
 *** Mounting bracket will interfere with manifolds on CH18-25/730-740 side mufflers. Also 24 164 04-S crossover manifold.

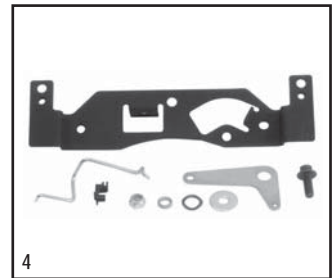
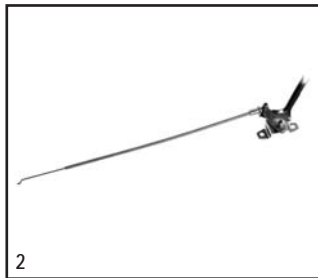

THROTTLE CONTROL

| Part No. | Description/Mount Type | Cable Length | Models | Item |
|-------------|-------------------------|--------------|--------|------|
| 63 089 23-S | Throttle Return Spring* | — | CS4-12 | 1 |
| 225011-2-S | Remote | 41-51" | All | 2 |
| 225011-6-S | Remote | 60-72" | All | 2 |
| 225011-7-S | Remote | 12-40" | All | 2 |
| 235160-S | Remote | 5.625" | All | 3 |

*For recreational vehicle applications. Returns engine speed to idle when foot pedal is released.

CHOKE CONTROL

| Part No. | Description/Mount Type | Models | Item |
|-------------|---|-----------------------------|------|
| 24 755 95-S | Choke Control Kit (Adds choke control lever to top controls.) | CV17-25/730-740 Com. Mowers | 4 |

REMOTE THROTTLE KITS

| Part No. | Description | Model | Item |
|-------------|---------------------|-----------|------|
| 17 755 04-S | Remote Throttle Kit | CH270 | 1 |
| 17 755 05-S | Remote Throttle Kit | CH395/440 | 2 |



CABLE CLAMP

| Part No. | Description | Models | Item |
|-------------|--|-----------|------|
| 17 237 13-S | Cable Clamp (Clamps braided throttle cable) | CH270-440 | 3 |
| 18 755 04-S | Barrel/Bowden Clamp | SH265 | — |



REMOTE CHOKE KITS

| Part No. | Description/Mount Type | Models | Item |
|-------------|---|-----------|------|
| 17 755 16-S | Remote Choke Kit (Fits Quad-Clean models) | CH395/440 | — |
| 17 755 17-S | Remote Choke Kit (Fits Low-Profile air cleaner models) | CH395/440 | 4 |

Electrical Accessories

HIGH TEMPERATURE CUTOUT SWITCH

| | | | |
|-------------|--------------|-------|-------------------------------------|
| Kit No. | Cutout Range | Reset | Models |
| 24 703 01-S | 440-490°F | 415°F | CH/CV17-26/ 730-745 SV710-740 |

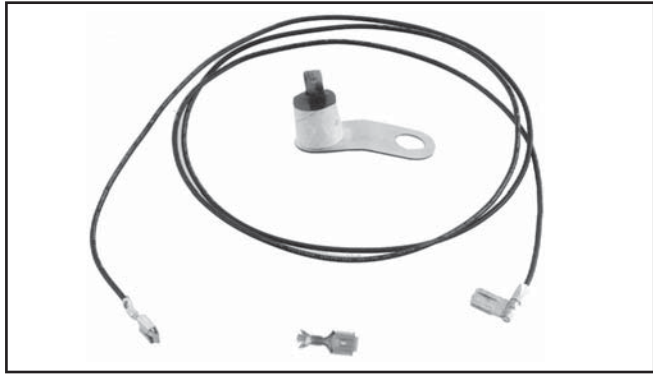

MALFUNCTION INDICATOR LAMP (MIL)

| | |
|-------------|---------------------------------|
| Part No. | Models With |
| 25 352 19-S | Electronic Fuel Injection (EFI) |
| 25 352 24-S | LED EFI |



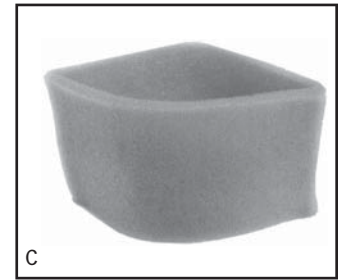
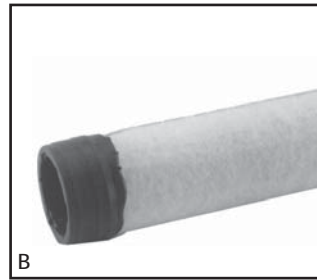
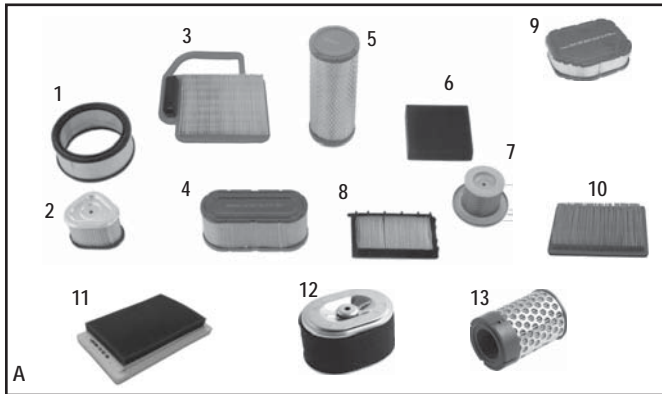

ELEMENTS & PRECLEANERS

Note: Elements and precleaners may appear differently for various models.

| Style | Element (Photo A) | U.L. Element Equivalent | Inner Element (Photo B) | Precleaner (Photo C) | Models |
|-------|----------------------|----------------------------|----------------------------|-------------------------|---|
| 1 | 45 083 02-S | 52 083 04-S | — | 45 083 01-S | CV17-26/730-745 (Commercial mowing) |
| 1 | 47 083 01-S | 47 083 04-S | — | 52 083 01-S | CH11-15 |
| 4 | 63 083 03-S | — | — | 63 083 04-S | CS4-6 (Standard, dual element) |
| 4 | 63 083 11-S | — | — | 63 083 12-S | CS8.5/250cc (Standard, dual element) |
| 4 | 63 083 01-S | — | — | 63 083 02-S | CS8.5/300cc, 10-12 (Standard, dual element) |
| 6 | 63 083 06-S | — | — | — | CS4-6 (Foam, single element) |
| 6 | 63 083 05-S | — | — | — | CS8.5/300cc, 10-12 (Foam, single element) |
| 7 | 63 083 07-S | — | — | 63 083 08-S | CS4-6 (Heavy-duty cyclonic) |
| 7 | 63 083 10-S | — | — | 63 083 09-S | CS8.5/250-300cc, 10-12 (Heavy-duty cyclonic) |
| 8 | 63 083 13-S | — | — | 63 083 14-S | CS8.5/250cc (Low profile, dual element) |
| 4 | 63 083 15-S | — | — | 63 083 16-S | CS10(931600), CS12 (941600) |
| 3 | 20 083 02-S | — | — | 20 083 04-S | SV470-620 |
| 2 | 12 083 05-S* | 12 083 09-S* | — | 12 083 08-S | CV11-16/460-493 (Standard, 2.8" High) |
| 2 | 12 083 10-S* | 12 083 13-S* | — | 12 083 12-S | CV11-16/460-493 (Tall, 3.4" High) |
| 1 | 47 083 03-S | 24 083 08-S | — | 24 083 02-S | CH/CV17-23 (Flat) |
| 1 | 24 083 03-S | 24 083 09-S | — | 24 083 05-S | CH/CV25-26/730-745, ECH/ECV630-749 (Flat) |
| 5 | 24 083 07-S | — | — | — | CH/CV17-22 Metal H.D. A/C |
| 5 | 25 083 01-S | — | 25 083 04-S | — | CH/CV17-26/620-745/LH640-775 Plastic H.D. A/C |
| 5 | 25 083 02-S | — | 25 083 03-S | — | ECH/ECV630-749 |
| 9 | 32 083 03-S | — | — | 32 083 05-S | CV493 |
| 9 | 32 083 06-S | — | — | 32 083 08-S | SV710-740 (Standard, 1.73" High) |
| 4 | 66 083 01-S | — | — | 66 083 03-S | SV810-840 (Large, 3" High) |
| 10 | 14 083 01-S | — | — | 14 083 02-S | LV625-680 |
| 11 | 14 083 09-S | — | — | — | XT-7 |
| 13 | 17 083 07-S | — | — | 17 083 12-S | XT-7 |
| 13 | 17 083 03-S | — | — | 17 083 15-S | CH270 |
| 12 | 18 083 04-S | — | — | 18 083 05-S | CH395/440 |
| 9 | 62 083 04-S | — | — | 62 083 03-S | SH265 |
| | | | | | CH940-1000 (with Low-Profile air cleaner) |

Notes: *Includes element and rubber seal.

ALSO SEE PAGE 18 FOR RECOIL STARTER FILTERS.

Air Intake

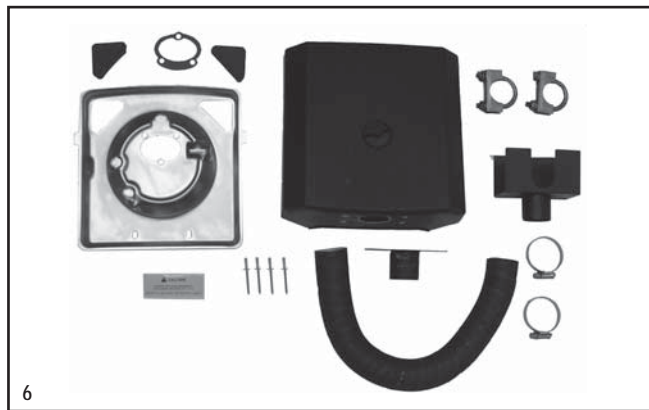
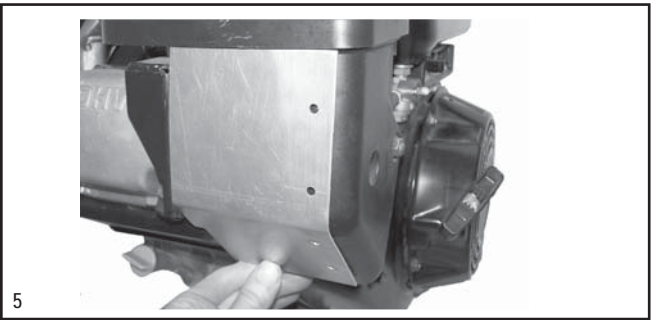
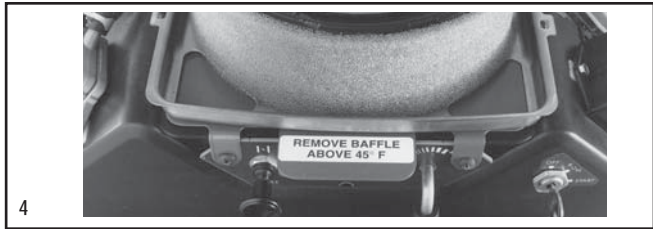
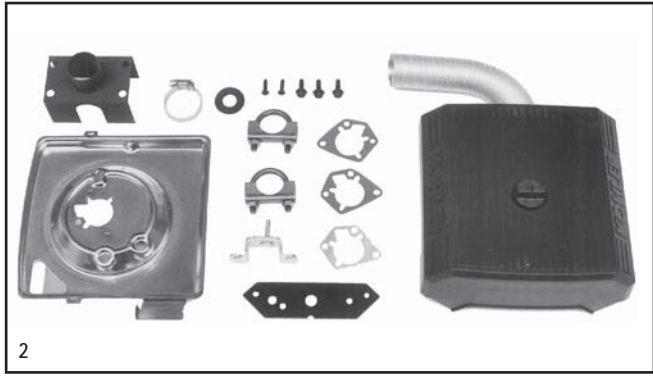
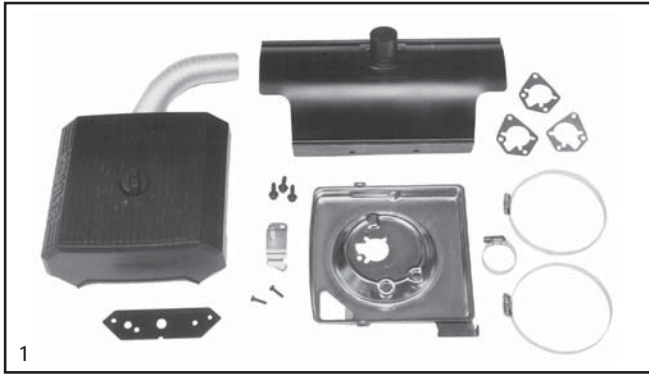

ANTI-ICING COMPONENTS

If the included instructions are followed, these kits/parts may be used without jeopardizing CARB/EPA certification on the engine.

| Kit No. | Models | As Low As | Notes | Heat From | Item |
|-----------------|-----------------------------------|-----------|----------------------------------|-----------|-----------|
| 24 755 64-S | CH18-22 | 20°F | For PTO mufflers | Muffler | 1 (shown) |
| 24 755 65-S | CH25-26/730-745 | 20°F | For PTO mufflers | Muffler | 1 |
| 24 755 68-S* | CH18-22 | 20°F | For side mufflers | Manifold | 2 (shown) |
| 24 755 69-S* | CH25-26/730-745 | 20°F | For side mufflers | Manifold | 2 |
| 24 755 82-S | CH18-26/730-745 | -20°F | Includes starter side muffler*** | Muffler | 3 |
| 24 755 83-S* | CH18-22 | -20°F | Includes filter side muffler*** | Muffler | 3 (shown) |
| 54 755 06-S** | CH/CV17-26/730-745, ECH630-749 | — | Not for comm'l. mowers | — | 4 |
| 63 755 39-S | CS8.5-12 | 20°F | — | — | 5 |
| 12 168 02-S | CH18-26/730-745 | — | Foam insulation only | — | — |
| 24 168 01-S | LH640-775 | — | Breather hose insulation | — | — |
| 24 755 165-S | CH750 w/Flat Air Cleaners | — | For side mufflers | Manifold | 6 |
| 12 326 28-S**** | CH11-15 | — | Insulated breather hose | — | 7 |
| 24 755 238-S | ECH630-749 | — | Includes starter side muffler | Muffler | — |

* Not for use on filter side of engine if equipped with oil cooler.

** Increases carb temperature approx. 13°F. Covers triangular holes (2) in blower housing. Remove above 45°F.

*** Tubes travel through mufflers to bring warm air to air cleaner.

**** Replaces existing breather hose to prevent icing, or order insulation only and install over existing hose.

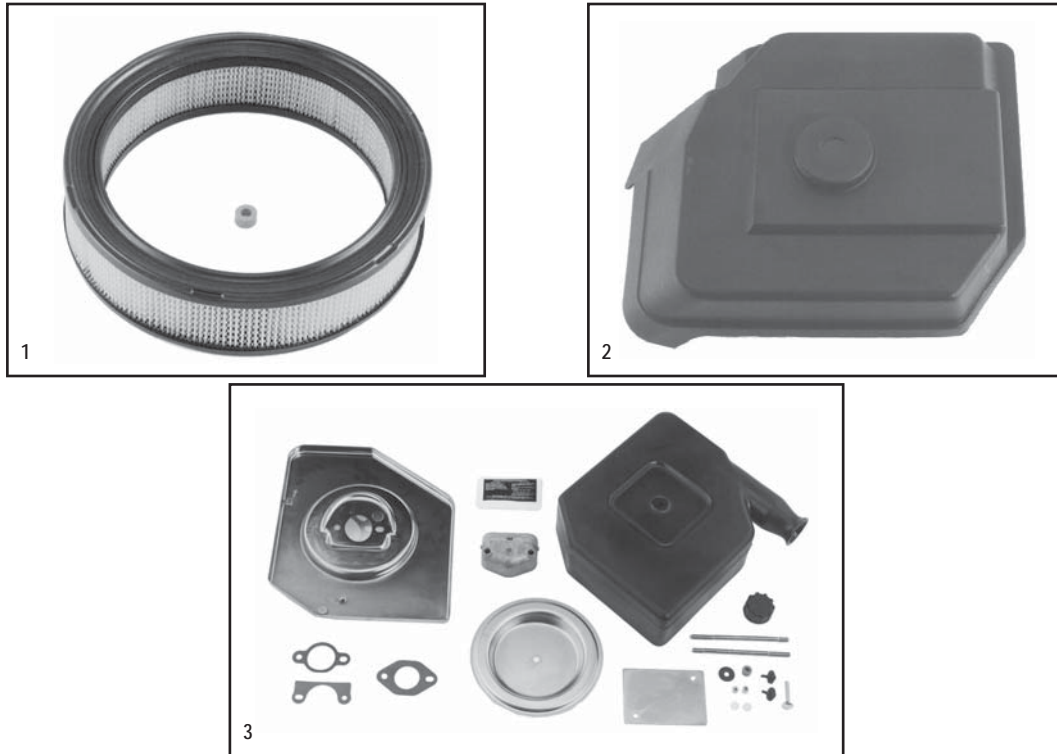

PLENUM DOME COVER KIT

| Kit No. | Snorkel O.D. | Hose Clamp | | Models | Item |
|-------------|--------------|------------|--|---------|------|
| | | Surface | | | |
| 12 743 10-S | 1.75" | 0.625" | | CH11-15 | 3 |

Note: May attach to customer-supplied remote-mount air cleaner or precleaner and hose. Requires Kohler review for CARB/EPA approval or if TT sheet guidelines for connections cannot be met.

SEAL RETROFIT KIT

| Kit No. | Description | Models | Item |
|-------------|-------------------|---------|------|
| 12 743 09-S | Seal Retrofit Kit | CH11-15 | 1 |

For engines before Serial No. 2519500004. Seal replaces loose washer and grommet in cover plate. Kit includes seal and element.

AIR CLEANER COVER

| Part No. | Description | Models | Item |
|-------------|--|---------|------|
| 12 096 41-S | Air Cleaner Cover (w/multilingual maintenance instructions) | CH11-15 | 2 |

Standard air cleaner cover, including multilingual maintenance instructions embossed underneath. Now available individually for engines built earlier.

AIR CLEANER COVER

| Part No. | Description | Models |
|-------------|---------------------------------|-----------------|
| 14 096 90-S | Air Cleaner Cover Kit (Snorkel) | XT-6, XT-7, XT8 |



Air Intake

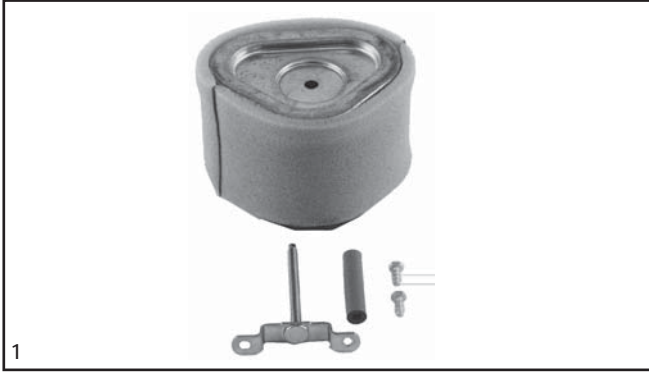

AIR CLEANER RETROFIT KITS

| Kit No. | Description |
|--|---|
| 12 743 03-S | Converts standard filter to a larger filter |
| 12 743 04-S | Cover has opening to line up with opening in blower housing |
| A — Pro Series "T/ST" after Serial No. 2404917244, Pro Series "S" after Serial No. 2424505854. | |
| B — Basic "S", lawn tractors. | |
| *Large capacity filter is 20% greater than standard filter. | |

| Includes Filter | For Spec. | Item |
|-----------------|-----------|------|
| Large* | A | 1 |
| Large* | B | 2 |

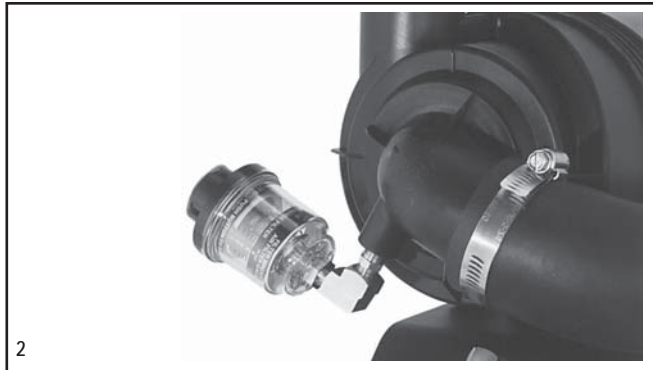

FILTER MINDER

Vacuum-type gauge detects air inlet restrictions, signaling when to service air filter (when yellow indicator reaches red line).

| Kit No. | Mounting | Air Drawn From | Models | Item |
|-------------|----------|--|--|------|
| 25 755 18-S | Remote | Air cleaner base plate or heavy-duty air cleaner elbow | CH/CV11-16/460-493, CH/CV17-26/730-745 | 1 |
| 25 755 24-S | Direct* | Heavy-duty air cleaner elbow | CH18-26/730-750, CV493 | 2 |
| 62 330 02-S | Direct | Heavy-duty air cleaner | CH/CV940-1000 | — |

* Includes brass fittings, instructions.

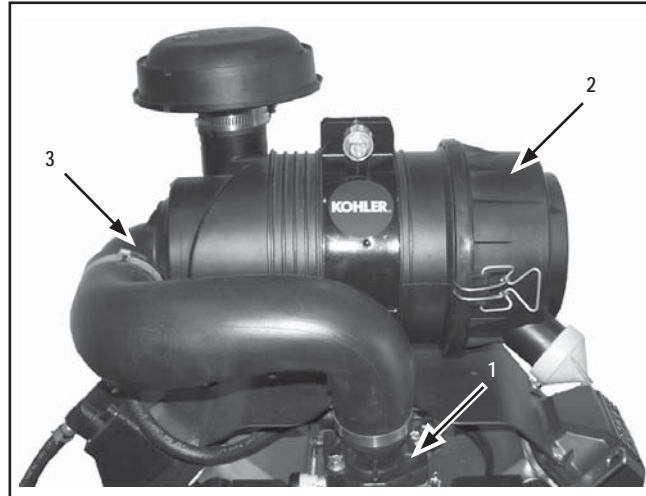

HEAVY-DUTY AIR CLEANER KITS (Convert from Flat Air Cleaner)

Complete, engine-mounted system (items 1 and 2 used together) is CARB/EPA certified. Any remote-mounting configuration (item 1 plus remote-mounted air cleaner), must be Kohler approved for CARB/EPA. Filtering area is 1,398 sq. in. Not usable on engines with plastic intake manifold.

| Kit No. | Description | Includes | Use With | Models | Item |
|-------------|--|----------|-------------|---------------------------------|------|
| 24 743 20-S | Elbow/Adapter Kit* | A | AA | CH18-22 (624cc)/620/640/730-740 | 1 |
| 24 743 25-S | Elbow/Adapter Kit | A | AA | CH22/23 (674cc)/680 | 1 |
| 24 743 21-S | Elbow/Adapter Kit | A | AA | CH25 | 1 |
| 24 743 34-S | Elbow/Adapter Kit | A | AA CH26/745 | EFI | 1 |
| 24 743 22-S | Air Cleaner Kit (90° canister elbow)** | B | BB | All | 2 |
| 24 743 23-S | Air Cleaner Kit (Straight canister elbow)*** | C | BB | All | 2 |
| 25 755 24-S | Filter Minder Kit (Elbow mounted)**** | D | AA | All | 3 |
| 25 755 18-S | Filter Minder Kit (Remote mounted)***** | E | AA | All | — |

* For CH730/740, carburetor replacement is necessary. Order assembly 24 853 93-S.

** Typically used for engine-mounted configuration (as shown). If remote-mounted, customer supplies hose (must be Kohler approved for CARB/EPA).

*** Used with customer-supplied hose for remote-mount location. (Must be Kohler approved for CARB/EPA).

**** Attaches to air canister elbow (per item 3). (See earlier page for description.)

***** Attaches to any remote location (front of engine, application, etc.). (See earlier page for description.)

Kits include instructions plus:

A - Elbow/adaptor, mounting bracket, 2" I.D. hose, hardware, debris shields for either knob-type or lever-type controls (see below).

B - Air cleaner canister, rain hood (25 324 04-S), main and inner filters, plug (25 139 20-S) to close Filter Minder opening if not used.

C - Air cleaner canister, rain hood (25 324 04-S), main and inner filters, cap (25 173 19-S) to close Filter Minder opening if not used.

D - Filter Minder, brass fittings.

E - Filter Minder, brass fittings, 10' hose, mounting bracket.

Use with:

AA - Air Cleaner Kit 24 743 22-S . . . or customer-supplied air cleaner, which must be Kohler approved for CARB/EPA.

BB - Elbow/Adapter Kit 24 743 20-S, 25-S, 21-S or 34-S.

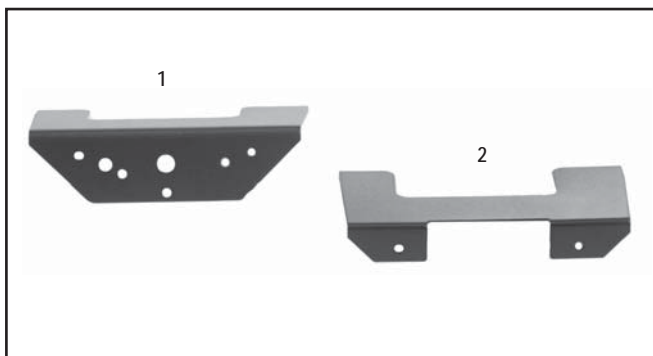

DEBRIS SHIELDS

Both shields are included in Heavy-Duty Air Cleaner Kits above (carb/elbow) to prevent debris from interfering with throttle/choke controls. (Only one shield needed depending upon engine spec.)

| Part No. | Used With | Models | Item |
|-------------|---|-------------------------------|------|
| 24 314 25-S | Knob-type controls, no controls, remote air cleaner | CH18-26/730-745 (shown above) | 1 |
| 24 314 29-S | Lever-type controls* | CH18-26/730-745 | 2 |

*Lever-type controls have been standard on CH18-25 panel specs since Serial No. 3009400011.

Air Intake

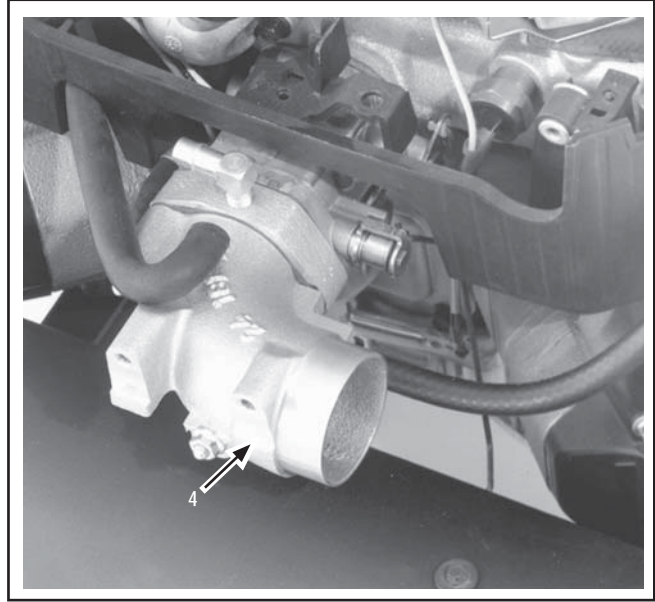
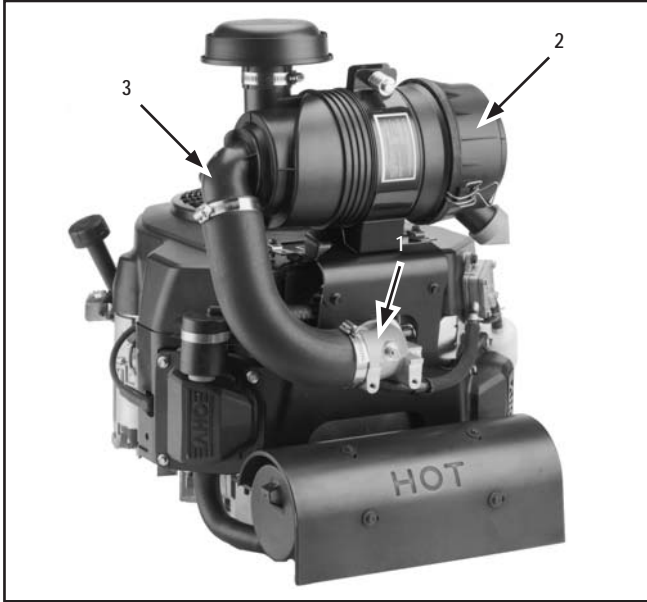

HEAVY-DUTY AIR CLEANER KITS (Convert from Flat or Commercial Mower Air Cleaner)

Complete, engine-mounted systems are CARB/EPA certified. Remote systems using either KOHLER or customer-supplied air cleaner and hose, must be Kohler approved for CARB/EPA. Filtering area is 1,398 sq. in. Not usable on Command engines with plastic intake manifold.

| Kit No. | Description | Includes | Use With | Models | Item |
|-------------|---|----------|----------|---------------------------------|------|
| 24 743 40-S | Elbow/Adapter Kit | A | AA | Command CV18-22 (624cc)/620-640 | 1 |
| 24 743 41-S | Elbow/Adapter Kit | A | AA | Command CV22/23 (674cc)/680 | 1 |
| 24 743 42-S | Elbow/Adapter Kit | A | AA | Command CV25/730-740 | 1 |
| 24 743 39-S | Complete Kit | B | - | Command CV26/745 EFI | 1,2 |
| 24 743 22-S | Air Cleaner Kit (90° canister elbow)* | C | BB | Command or Aegis***** | 2 |
| 24 743 23-S | Air Cleaner Kit (straight canister elbow)** | D | BB | Command or Aegis***** | 2 |
| 66 743 01-S | Elbow/Adapter Kit (remote only) | E | CC | Aegis LV625-675 | 4 |
| 25 755 24-S | Filter Minder Kit (Elbow-mounted***) | F | AA | All | 3 |
| 25 755 18-S | Filter Minder Kit (Remote-mounted****) | G | AA | All | - |

* Typically used for engine-mounted configuration (as shown). Not compatible with vertical positioned mufflers as shown in EXHAUST section.

** Used with customer-supplied hose for remote-mount location. (Must be Kohler-approved for CARB/EPA).

*** Attaches to outlet in canister. (See appearance and description of Filter Minder on earlier page.)

**** Attaches to any remote location. (See appearance and description of Filter Minder on earlier page.)

***** Usable on Aegis but only in remote-mount configuration, not engine-mounted.

Kits include instructions plus:

A - Carburetor, elbow/adapter, mounting brackets, 2" I.D. hose, hardware.

B - Elbow/adapter, mounting brackets, 2" I.D. hose, hardware, plus C.

C - Air cleaner canister(†), rain hood (25 324 04-S), main and inner filters, plug (25 139 20-S) to close Filter Minder opening if not used.

D - Air cleaner canister(‡), rain hood (25 324 04-S), main and inner filters, cap (25 173 19-S) to close Filter Minder opening if not used.

E - Elbow/adapter, air cleaner gaskets, misc. hardware. Customer supplies 2" I.D. remote hose to air cleaner. (Must be Kohler-approved for CARB/EPA.)

F - Filter Minder, brass fittings.

G - Filter Minder, brass fittings, 10' hose, mounting bracket.

(†) 90° air cleaner canister is comprised of: 25 081 01-S main body, 25 096 06-S end cap w/ejector valve & clips.

(‡) Straight air cleaner canister is comprised of: no - S part number for main body, 25 096 06-S end cap w/ejector valve & clips.

Use with:

AA - Air Cleaner Kit 24 743 22-S . . . or customer-supplied air cleaner and hose, which must be Kohler-approved for CARB/EPA.

BB - Elbow/Adapter Kit 24 743 36-S, 37-S and 38-S; or 66 743 01-S (remote-mount only).

CC - Air Cleaner Kit 24 743 22-S or 23-S may only be used in remote-mounted configuration, not engine-mounted. Customer supplies 2" I.D. hose. (Must be Kohler-approved for CARB/EPA.)

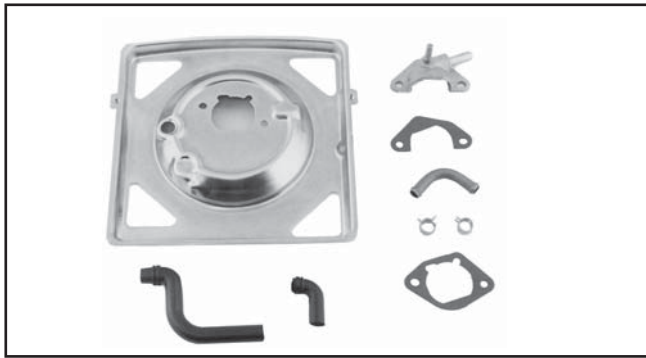

AIR CLEANER BASE/BREATHER KIT

| Kit No. | Description | Models |
|-------------|-------------------|-----------------|
| 24 755 86-S | Base/breather kit | CV17-25/730-740 |

Note: Breather system for models with accelerator pump carburetor.

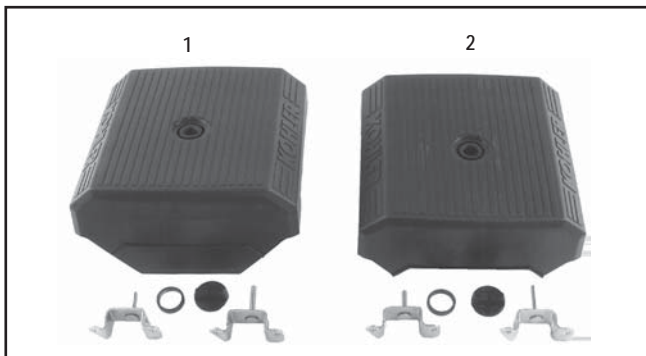

AIR CLEANER COVER KITS STANDARD

| Kit No. | For Engine With | Models | Item |
|-------------|------------------|---------------------|------|
| 24 743 05-S | No control panel | CH/CV17-25/730-740* | 1 |
| 24 743 06-S | Control panel | CH18-26/730-740 | 2 |

Note: Covers include embossed KOHLER name on outside, maintenance instructions on inside (English, Spanish, German, French).
*CV17-25/730-740 with standard air cleaner also requires 24 755 86-S kit (above).

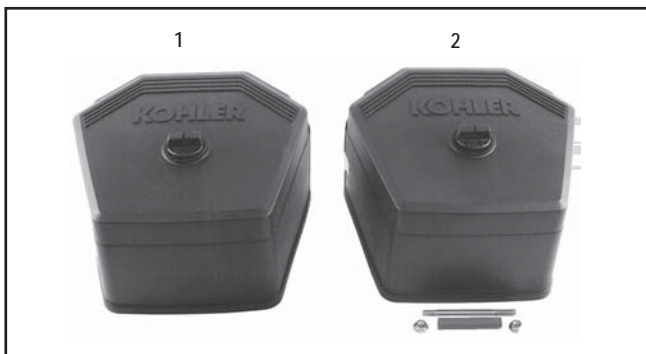

AIR CLEANER COVER KITS COMMERCIAL MOWER

| Kit No. | Models | Item |
|---------------|-----------------|------|
| 24 743 11-S* | CV17-25/730-740 | 1 |
| 24 743 17-S** | CV17-25/730-740 | 2 |
| 24 743 32-S** | CV26/745 | 2 |

Note: Covers include embossed KOHLER name on outside, maintenance instructions on inside (English, Spanish, German, French).

* Cover is made of high-temp material for extreme conditions.
** Same as -11-S kit, but includes stud, seal and nuts for high-moisture conditions preventing water see page under cover.



KNOB REPLACEMENT KIT

| Kit No. | Description | Models |
|-------------|-------------|--------------------|
| 54 755 01-S | Knob Kit | CH/CV17-26/730-750 |

Exhaust

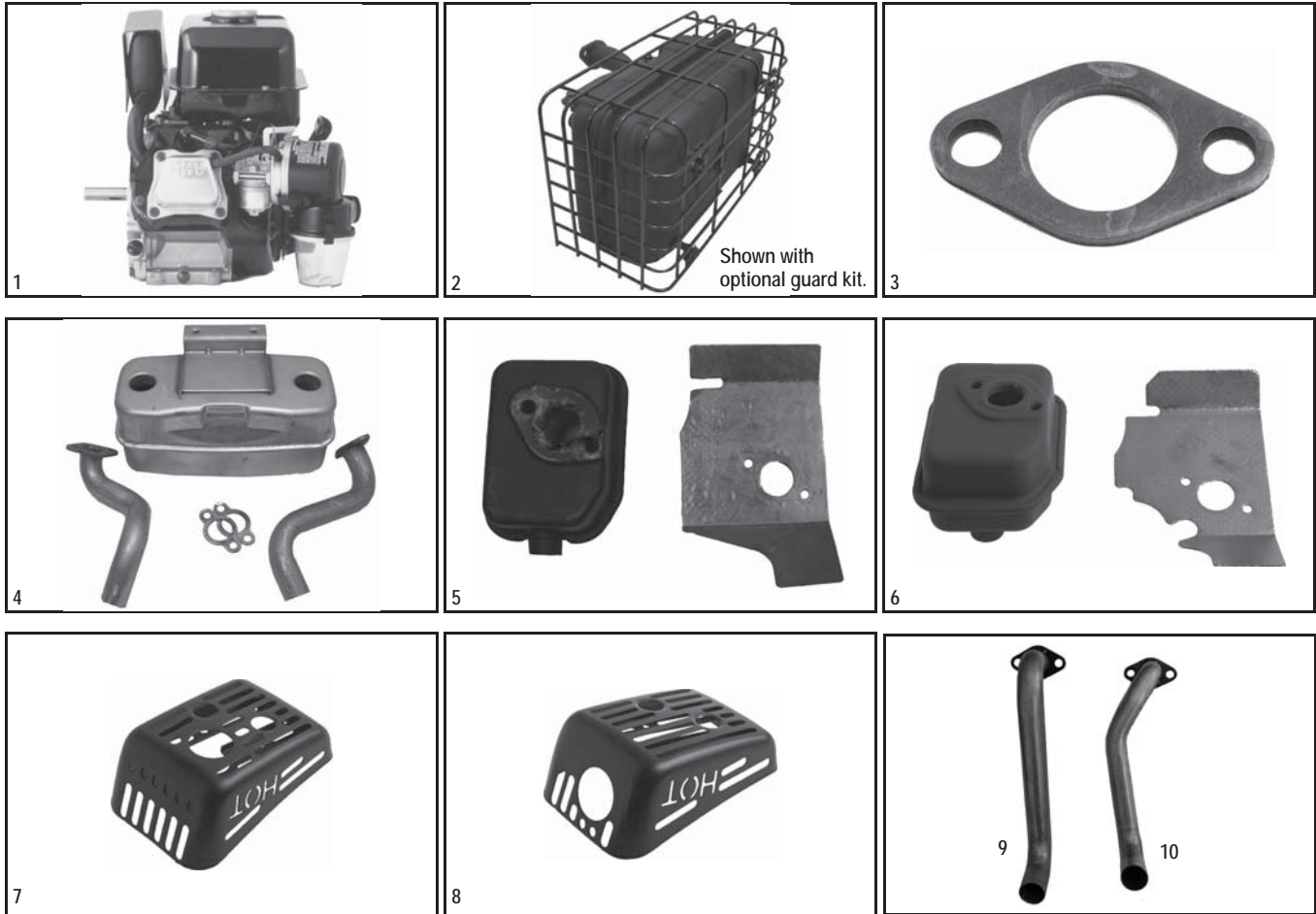

CS4-6 MUFFLER

Kit includes muffler and gasket. Use hardware from existing muffler.

| Kit No. | Outlet Location | Outlet O.D. | Muffler Length | Outlet Tube Length | Models | Item |
|-------------|-----------------|-------------|----------------|--------------------|--------|------|
| 63 786 01-S | Throttle Side* | 1.0" | 9.46" | 1.0" | CS4-6 | 1 |

*Outlet is on opposite side of standard muffler location. Also allows for unobstructed PTO face.

COURAGE SINGLE (SV470-620) MUFFLER KIT

Kit includes muffler, gasket, support bracket, hardware and instructions.

| Kit No. | Description | Engine Side | Outlet D.B.C. | Item |
|----------------|-------------|-------------|---------------|------|
| 20 786 02-S*** | Muffler Kit | Starter | 2.047 | 2 |
| 20 755 10-S | Guard Kit* | | | 2 |
| 12 755 107-S | Guard Kit** | | | 2 |

*Cage open at bottom to avoid interference with deck.

**Cage closed at bottom.

***Not compliant for California.

COURAGE SINGLE EXHAUST FLANGE

For adapting manifold length to customer-supplied exhaust.

| Part No. | Description | Models | Item |
|-------------|--------------------|-----------|------|
| 20 295 01-S | Steel, 0.188 thick | SV470-620 | 3 |

COURAGE TWIN (SV710-840) MUFFLER KIT

Kit includes muffler, gasket, slip-fit manifolds, and screws. Customer supplies mounting bracket to frame.

| Kit No. | Muffler Only | Outlet Location/Direction | Item |
|-------------|--------------|---------------------------|------|
| 32 786 01-S | 32 068 01-S | Bottom/Toward Oil Filter | 4 |

COURAGE TWIN EXTENDED MANIFOLDS

| Part No. | Description | Item |
|-------------|-------------|------|
| 32 164 06-S | | 9 |
| 32 164 07-S | | 10 |

XT (COURAGE) MUFFLER KIT

Kit includes muffler and heat deflector.

| Kit No. | Choke Type | Outlet Location/Direction | Item |
|-------------|---------------|---------------------------|------|
| 14 068 01-S | Manual/Primer | Front Discharge | 5 |
| 14 068 08-S | Manual/Primer | Side Discharge | 6 |
| 14 068 05-S | Auto | Front Discharge | - |
| 14 068 07-S | Auto | Side Discharge | - |

XT (COURAGE) MUFFLER GUARD

| Part No. | Description | Item |
|-------------|------------------------------|------|
| 14 314 04-S | For front discharge mufflers | 7 |
| 14 314 09-S | For side discharge mufflers | 8 |

COMMAND PRO HORIZONTAL MUFFLERS

| Part No. | Description | Models | Item |
|-------------|-------------|--------|------|
| 17 068 31-S | Low profile | CH270 | - |
| 17 068 38-S | Low profile | CH395 | - |
| 17 068 40-S | Low profile | CH440 | 1 |



COURAGE HORIZONTAL MUFFLERS

| Part No. | Description | Item |
|-------------|---------------------|------|
| 18 068 08-S | Low profile muffler | 1 |
| 18 068 14-S | Muffler & deflector | - |



Exhaust

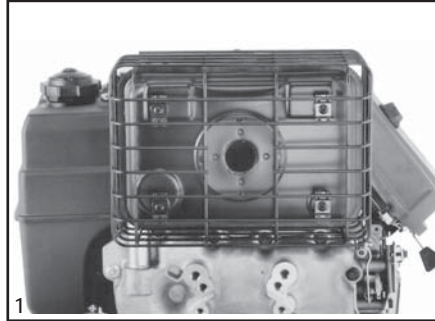

1 Includes Exhaust Deflector (not shown).



2 Includes Exhaust Deflector (not shown).

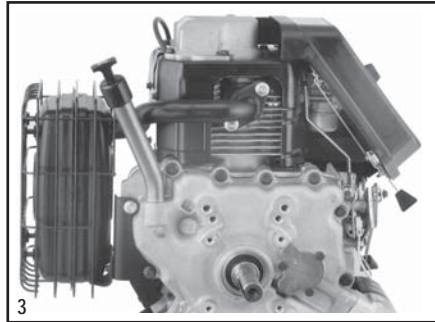

3 Vertical Orientation

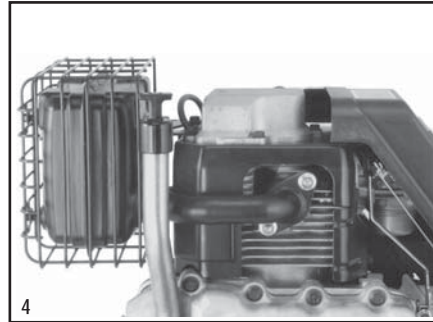

4 Horizontal Orientation

PILLOW MUFFLERS & GUARDS (CH11-15)

Muffler kits include oil fill tube/dipstick as pictured . . . to avoid interference with muffler or guard . . . including sealant and a driver to aid in installation. Mufflers have stand offs for attaching optional wire guard. Guard kits do not include muffler.

| Part No. | Muff. Only | Description | Engine Side | Outlet D.B.C. | A | B | C | D | E | F | G | H | Item |
|---------------|-----------------|----------------|------------------|---------------|-------|--------|--------|---------|-------|--------|-------|------|------|
| 12 786 09-S* | 12 068 26-S | Muffler Kit | PTO | 2.047" | 13.0" | — | 7.0" | — | 5.0" | — | 4.25" | — | 1 |
| 12 786 13-S** | 12 068 38-S | Muffler Kit | PTO | 2.047" | 13.0" | — | 7.0" | — | 5.0" | — | 4.25" | — | 1 |
| 12 755 107-S | — | Guard Kit | PTO | — | — | 13.5" | — | 6.25" | — | 5.5" | — | 5.0" | 1 |
| 12 786 08-S* | 12 068 25-S | Muffler Kit | Top | 2.047" | 17.0" | — | 13.25" | — | 4.5" | — | — | — | 2 |
| 12 786 12-S** | 12 068 39-S | Muffler Kit | Top | 2.047" | 17.0" | — | 13.25" | — | 4.5" | — | — | — | 2 |
| 12 755 107-S | — | Guard Kit | Top | — | — | 17.75" | — | 13.125" | — | 5.0" | — | — | 2 |
| 12 786 10-S* | 12 068 27-S | Muffler Kit*** | Starter, No Tank | 2.047" | 8.0" | — | 1.0" | — | 11.0" | — | — | — | 3 |
| 12 786 14-S** | 12 068 41-S | Muffler Kit*** | Starter, No Tank | 2.047" | 8.0" | — | 1.0" | — | 11.0" | — | — | — | 3 |
| 12 755 72-S | — | Guard Kit | Starter, No Tank | — | — | 8.5" | — | 1.5" | — | 11.75" | — | — | 3 |
| 12 786 11-S* | 12 068 23-S | Muffler Kit | Starter, No Tank | 2.047" | 13.0" | — | 7.0" | — | 10.0" | — | — | — | 4 |
| 12 786 15-S** | 12 068 40-S | Muffler Kit | Starter, No Tank | 2.047" | 13.0" | — | 7.0" | — | 10.0" | — | — | — | 4 |
| — | **12 068 30-S** | Muffler**** | Starter, No Tank | 2.047" | 13.0" | — | 7.0" | — | 10.0" | — | — | — | 4 |
| 12 755 107-S | — | Guard Kit | Starter, No Tank | — | — | 13.75" | — | 6.25" | — | 10.5" | — | — | 4 |

* Muffler has no integral port liner. It is usable only on CH11-14 models below Serial No. 2628900001.

** Muffler has integral port liner extending from mounting flange, to interface with cored-out cylinder head. Only for models with Serial No. 2628900001 or higher, which include cored-out cylinder head.

*** Muffler kit not usable on specs with fuel pump.

**** For CH14 LP engines only; includes oxygen sensor port in manifold-to-muffler pipe.

- | | |
|---|--|
| A — Centerline of crank to top of muffler. | E — Centerline of crank to left edge of muffler. |
| B — Centerline of crank to top of guard. | F — Centerline of crank to left edge of guard. |
| C — Centerline of crank to bottom of muffler. | G — From PTO face to farthest edge of muffler. |
| D — Centerline of crank to bottom of guard. | H — From PTO face to farthest edge of guard. |

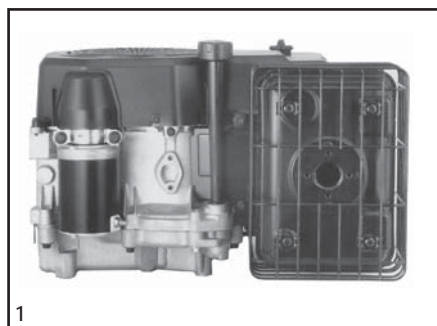

1 Vertical Orientation (Standard)

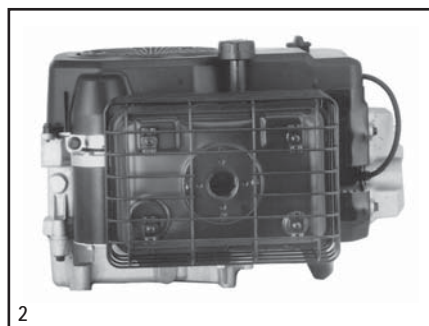

2 Horizontal Orientation

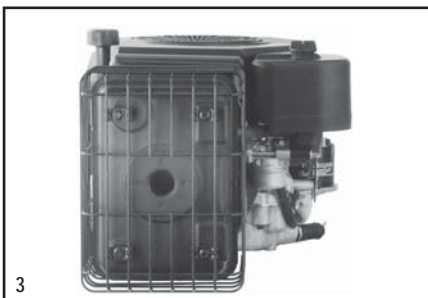

3 Valve Cover Orientation

PILLOW MUFFLERS & GUARDS (CV11-16/460-493)

Guard kits do not include muffler. Note: Mufflers 12 068 54-S and 55-S are exclusive to CV460-493, 12 068 39-S is also useable. No other mufflers are usable on these Models.

| Part No. | Description | Engine Side | Stand Offs For Guard | Hardware (See note) | Outlet D.B.C. | A | B | C | D | E | F | Item |
|---------------|--------------------|-------------|----------------------|---------------------|---------------|------------------|-------|--------|--------|-------|-------|------|
| 12 068 21-S* | Muffler (Standard) | Starter | No | 1 | 2.047" | 12.0" | — | 0.75" | — | 4.5" | — | 1 |
| 12 068 44-S** | Muffler (Standard) | Starter | No | 1 | 2.047" | 12.0" | — | 10.75" | — | 4.5" | — | 1 |
| 12 068 54-S** | Muffler | Starter | No | 1 | 2.047" | 12.47" | — | 10.75" | — | 4.5" | — | 1 |
| 12 068 23-S* | Muffler | Starter | Yes | 1 | 2.047" | 12.0" | — | 10.75" | — | 4.5" | — | 1 |
| 12 068 40-S** | Muffler | Starter | Yes | 1 | 2.047" | 12.0" | — | 10.75" | — | 4.5" | — | 1 |
| 12 068 30-S** | Muffler*** | Starter | Yes | 1 | 2.047" | 12.0" | — | 10.75" | — | 4.5" | — | 1 |
| 12 068 55-S** | Muffler | Starter | Yes | 1 | 2.047" | 12.47" | — | 10.75" | — | 4.5" | — | 1 |
| 12 755 107-S | Guard Kit | Starter | — | — | — | — | 12.5" | — | 11.25" | — | 5.25" | 1 |
| | | | | | | (12.97"/460-493) | | | | | | |
| 12 068 20-S* | Muffler*** | Starter | No | 2 | 2.047" | 8.0" | — | 9.25" | — | 3.75" | — | 2 |
| 12 068 42-S** | Muffler*** | Starter | No | 2 | 2.047" | 8.0" | — | 9.25" | — | 3.75" | — | 2 |
| 12 068 27-S* | Muffler*** | Starter | Yes | 2 | 2.047" | 8.0" | — | 9.25" | — | 3.75" | — | 2 |
| 12 755 72-S | Guard Kit | Starter | — | — | — | — | 8.5" | — | 9.75" | — | 4.25" | 2 |
| 12 068 25-S* | Muffler | Valve | Yes | 3 | 2.047" | 2.5" | — | 10.5" | — | — | — | 3 |
| 12 068 39-S** | Muffler | Valve | Yes | 3 | 2.047" | 2.5" | — | 10.5" | — | — | — | 3 |

* Muffler has no integral port liner. It is usable only on CV11-14 models below Serial No. 2628900001.

** Muffler has integral port liner extending from mounting flange, to interface with cored-out cylinder head. Only for models with Serial No. 2628900001 or higher, which include cored-out cylinder head.

*** Muffler not usable on specs with fuel pump.

**** For CV14 LP engines only; includes oxygen sensor port in manifold-to-muffler pipe.

Note: for mufflers 12 068 25-S and 12 068 39-S, only guard 12 755 107-S is necessary for EEC. Mufflers 12 068 20-S, 12 068 21-S, 12 068 42-S and 12 068 44-S do not have weld nuts for guard attachment, so they cannot be made EEC-compliant.

A — Centerline of crank to right edge of muffler.

B — Centerline of crank to right edge of guard.

C — Mounting surface to top of muffler.

D — Mounting surface to top of guard.

E — Centerline of oil fill cap to outer edge of muffler.

F — Centerline of oil fill cap to outer edge of guard.

Mounting Hardware (if not presently on engine)

1 - Order (1) 12 126 71-S bracket, (2) M-645025-S screw, (1) M-545016-S screw, (2) M-841080 nut, (1) X-25-78-S washer. (2) 12 112 20-S spacer (sheet metal valve cover only).

2 - Order 12 755 30-S mounting kit.

3 - Order (1) 12 126 56-S bracket, (2) M-645025-S screw, (2) M-645015-S screw, (1) 12 041 03-S gasket, (2) M-841060-S nut, (2) 12 112 20-S spacer (sheet metal valve cover only).

Exhaust

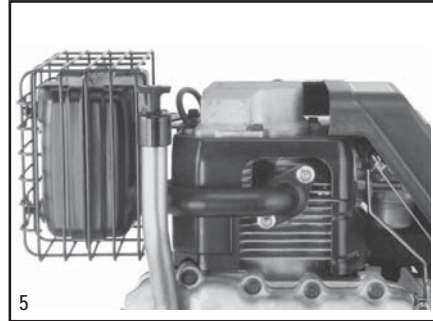
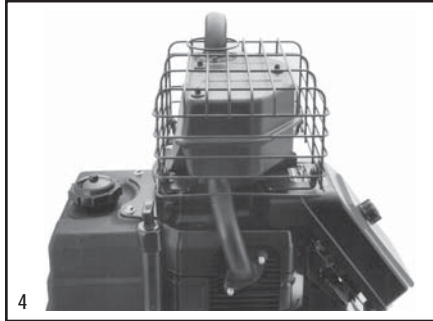
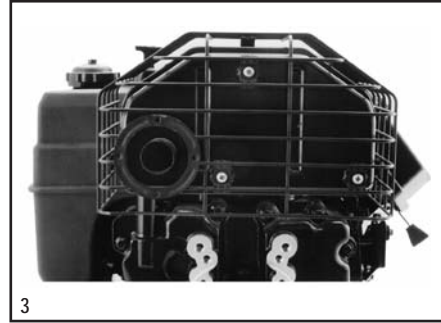
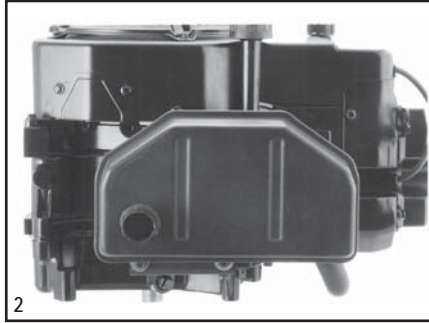
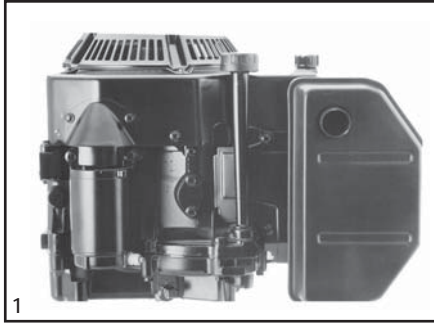

HAM CAN MUFFLERS (CH/CV11-15)

CV Models

CH Models

| Part No. | Description | Outlet O.D. | A | Side | Item |
|-------------|---------------|-------------|-------|---------|------|
| 12 068 01-S | Muffler | 1.25" | 4.94" | Starter | 1 |
| 12 786 18-S | Mounting Kit* | — | — | Starter | 1 |
| 12 068 03-S | Muffler | 1.25" | 6.5" | Starter | 2 |
| 12 068 35-S | Muffler** | 1.25" | 6.5" | Starter | 2 |
| 12 755 30-S | Mounting Kit* | — | — | Starter | 2 |

A — Extends away from blower housing.

* Includes bracketry, gasket, hardware.

** Identical to the -03 muffler, but includes integral port liner extending from the mounting flange. Only ham can muffler usable on CV11-15 models with cored-out cylinder head, Serial No. 2628900001 and higher.

| Part No. | Description | Outlet D.B.C. | Space | Side | Item |
|-------------|------------------------|---------------|-------|---------|------|
| 12 068 11-S | Muffler only** | 2.047" | B | PTO | 3 |
| 12 786 04-S | Mounting Kit *** | — | — | PTO | 3 |
| 12 755 26-S | Guard Kit | — | B | PTO | 3 |
| 12 068 11-S | Muffler only** | 2.047" | C | Top | 4 |
| 12 786 03-S | Mounting/Guard Kit**** | — | C | Top | 4 |
| 12 068 11-S | Muffler only | 2.047" | D | Starter | 5 |
| 12 786 02-S | Mounting Kit*** | — | — | Starter | 5 |
| 12 755 26-S | Guard Kit | — | D | Starter | 5 |

** Shown with deflector, not included.

*** Includes manifold, bracketry, gaskets, hardware.

**** Includes manifold, bracketry, exhaust deflector, gasket, guard, hardware.

B — From centerline of crank to top of muffler is 12.5"; to top of guard is 13"; to bottom of guard is 6". From PTO face to guard at farthest point is 5.5"; to muffler is 5".

C — From centerline of crank to top of guard is 18.5"; to top of deflector is 20.55".

D — From centerline of crank to left edge of guard is 11.25"; to left edge of muffler is 10.75".

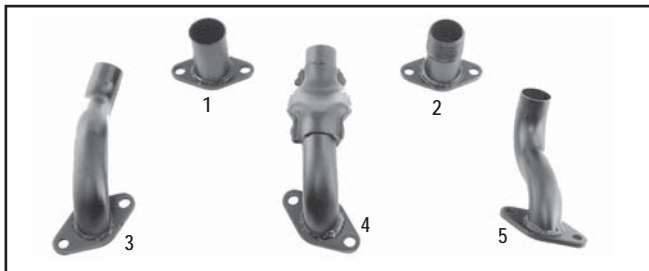

MANIFOLDS

| Part No. | Outlet O.D. | Models | For Muffler | Item |
|---------------|-------------|---------|------------------|------|
| 12 164 03-S | 1.312" | CH11-15 | Various | 1 |
| 12 164 04-S* | — | CH11-15 | Pepperpot | 2 |
| 12 164 05-S** | — | CH11-15 | Pepperpot | 3 |
| 12 382 01-S | 1.125" | CH11-15 | Ham Can, Top | 3 |
| 12 382 02-S | 1.125" | CH11-15 | Ham Can, Starter | 4 |
| 12 382 03-S | 1.125" | CH11-15 | Ham Can, PTO | 5 |

* 1.0" N.P.T. external thread.

** Same as 12 382 01-S, except 1.0" N.P.T. external thread.



EXHAUST FLANGE (CH/CV11-15)

For adapting manifold length to customer-supplied exhaust.

| Part No. | Description | Models |
|-------------|---------------------|------------|
| 12 295 01-S | Steel, 0.188" thick | CH/CV11-15 |

MISCELLANEOUS MUFFLERS

CV Models



CH Models

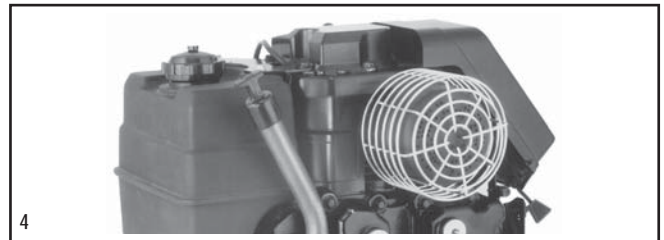
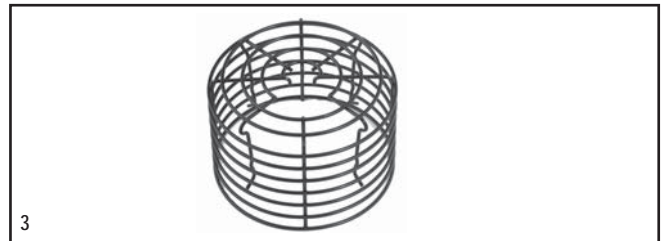
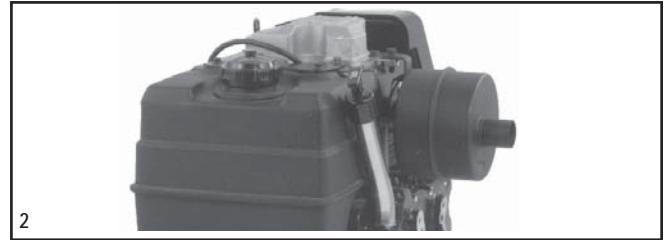

| Part No. | Description | Engine Side | Outlet O.D. | Item |
|----------------|-------------|-------------|-------------|------|
| 12 068 57-S* | Muffler | Valve Cover | 1.25" | 1 |
| 12 755 20-S** | Muffler Kit | Valve Cover | 1.25" | 2 |
| 12 068 49-S*** | Muffler | Valve Cover | 1.125" | 3 |

* Includes integral heat shield and exhaust deflector. Also order (2) M-841080-S nut, (1) 12 041 03-S gasket, (1) 25 086 16-S screw, (1) X-25-95-S spacer, (1) X-20-1-S lock washer, (1) 25 100 20-S nut. Muffler extends 5.625" from valve cover. (1) M-645025-S screw, (1) 12 112 20-S spacer (if engine has stamped steel valve cover).

** Includes integral guard. Muffler extends 7" from blower housing.

***Also order (1) 12 041 03-S gasket, (2) M-841060-S nuts, (2) 12 112 20-S spacers, (4) M-645016 screws, and (2) M-645025 screws.

| Kit No. | Muff. Only | Description (Ideal For) | Engine Side | Item |
|---------------|------------------------------|-------------------------|-------------|------|
| 12 786 16-S* | 12 068 58-S* (Aluminized) | Round (Compressors) | Top | 1 |
| 12 786 20-S | 12 068 51-S | Round (Press. Washers) | Above PTO | 2 |
| 12 314 32-S | — | Guard for 1 & 2 | — | 3 |
| 12 786 05-S** | 275679-S | Pepperpot-Thread On | Above PTO | 4 |
| 25 314 01-S | — | Guard only | — | 4 |

* Includes angled oil fill tube and dipstick to clear muffler, plus mounting bracket and hardware. Muffler outlet is 5.5" above valve cover. Outlet O.D. is 1.25".

**Includes muffler, manifold, gasket, hardware. Muffler has 1.0" N.P.T. internal thread. Not usable if engine requires CARB/EPA certification.

& Aluminized steel canister.

Exhaust



Shown: 24 068 27-S Quiet version.
(Mufflers will fit with top-mount controls only.)



Shown: 24 068 27-S Quiet version.
(Mufflers will fit with top-mount controls only.)

COMMERCIAL MOWER CANISTER MUFFLERS — HEAT SHIELDS REQUIRED. SEE BELOW.

| Part No. | Outlet Location/Direction | Outlet O.D. | Muffler Dia. | Muffler Length | A | B | Models |
|-------------|---------------------------|-------------|--------------|----------------|------|-------|-----------------------------------|
| 24 068 09-S | Starter Side/Straight | 1.375" | 4.0" | 12.0" | 1.0" | 4.75" | CV17-25/620-730,740,750,LV625-680 |
| 24 068 08-S | Filter Side/Straight | 1.375" | 4.0" | 12.0" | 1.0" | 4.75" | CV17-25/620-730,740,750,LV625-680 |
| 24 068 20-S | Filter Side/Down | 1.375" | 4.0" | 12.0" | 1.0" | 4.75" | CV17-25/620-730,740,750,LV625-680 |
| 24 068 21-S | Filter Side/Extended | 1.375" | 4.0" | 12.0" | 1.0" | 4.75" | CV17-25/620-730,740,750,LV625-680 |

Note: For mounting, order (2) 24 041 49-S gasket, (2) 24 072 08-S stud, (2) M-641060-S nut, (4) 25 100 52-S nut.

QUIET CANISTER MUFFLERS — HEAT SHIELDS REQUIRED. SEE BELOW.

These mufflers are larger than those above, and also up to 4 dBA quieter (@3600 RPM, WOT).

| Kit No. | Muffler Only | Outlet Location/Direction | Outlet O.D. | Muffler Dia. | Muffler Length | A | B | Models |
|-------------|--------------------------|---------------------------|-------------|--------------|----------------|------|------|-----------------------------------|
| — | 24 068 25-S | Center/Straight | 1.375" | 4.62" | 16.0" | 1.0" | 5.5" | CV17-25/620-730,740,750,LV625-680 |
| — | 24 068 27-S | Starter Side/Straight | 1.375" | 4.62" | 16.0" | 1.0" | 5.5" | CV17-25/620-730,740,750,LV625-680 |
| — | 24 068 29-S | Filter Side/Straight | 1.375" | 4.62" | 16.0" | 1.0" | 5.5" | CV17-25/620-730,740,750,LV625-680 |
| — | 24 068 28-S | Filter Side/Down | 1.375" | 4.62" | 16.0" | 1.0" | 5.5" | CV17-25/620-730,740,750,LV625-680 |
| — | 24 068 26-S | Filter Side/Extended | 1.375" | 4.62" | 16.0" | 1.0" | 5.5" | CV17-25/620-730,740,750,LV625-680 |
| — | 24 068 58-S [‡] | Filter Side/Straight | 1.375" | 4.62" | 16.0" | 1.0" | 5.5" | CV17-25/620-730,740,750,LV625-680 |
| — | 24 068 43-S | Center/Straight | 1.375" | 4.62" | 16.0" | 1.0" | 5.5" | CV26/745EFI, ECV630-749 |
| 24 786 28-S | 24 068 45-S | Starter Side/Straight | 1.375" | 4.62" | 16.0" | 1.0" | 5.5" | CV26/745EFI, ECV630-749 |
| 24 786 29-S | 24 068 47-S | Filter Side/Straight | 1.375" | 4.62" | 16.0" | 1.0" | 5.5" | CV26/745EFI, ECV630-749 |
| 24 786 30-S | 24 068 46-S | Filter Side/Down | 1.375" | 4.62" | 16.0" | 1.0" | 5.5" | CV26/745EFI, ECV630-749 |

A — Mounting surface to bottom of muffler.

B — Mounting surface to top of muffler.

Note: For mounting, order (2) 24 041 49-S gasket, (2) 24 072 08-S stud, (2) M-641060-S nut, (4) 25 100 52-S nut.

[‡]Aluminized steel canister.



HEAT SHIELDS FOR CANISTER MUFFLERS

Kohler requires a heat shield between muffler and air cleaner.

| Part No. | Designed for Mufflers |
|--------------------------|-------------------------------------|
| 24 281 06-S* | 24 068 08-S, 09-S, 20-S, 21-S |
| 24 314 51-S [‡] | 24 068 26-S, 27-S, 28-S, 29-S, 58-S |
| 24 281 14-S* | 24 068 25-S |
| 24 281 15-S* | 24 068 44-S, 45-S, 46-S, 47-S |

*Order (4) 25 086 40-S screws for mounting heat shield.

[‡]Aluminized steel to match muffler.



1
FLAT AIR CLEANER



2
COMMERCIAL MOWER AIR CLEANER

VERTICAL MUFFLER KITS* (CV17-740,750)

| Kit No. | Muff. Only | Location | Outlet D.B.C. | A | B | Item |
|-------------|-------------|--------------|---------------|------|------|-----------|
| 24 786 13-S | 24 068 19-S | Starter Side | 3.06" | 3.0" | 3.5" | 1 (Shown) |
| 24 786 14-S | 24 068 19-S | Filter Side | 3.06" | 3.0" | 3.5" | 1 |
| 24 786 15-S | 24 068 22-S | Starter Side | 3.06" | — | — | 2 (Shown) |
| 24 786 16-S | 24 068 22-S | Filter Side | 3.06" | — | — | 2 |

*Includes muffler, manifold, brackets, heat deflector, clamp, gaskets, and hardware.

A — Extends forward of air cleaner.

B — Extends right (or left) of valve cover.

CROSSOVER MANIFOLDS USED IN KITS ABOVE

| Part No. | Outlet Location | Outlet O.D. | Item |
|-------------|--------------------|-------------|------|
| 24 164 12-S | Starter Side, Down | 1.125" | 3 |
| 24 164 13-S | Filter Side, Down | 1.125" | 4 |
| 24 164 16-S | Starter Side, Up | 1.125" | 1 |
| 24 164 17-S | Filter Side, Up | 1.125" | 2 |

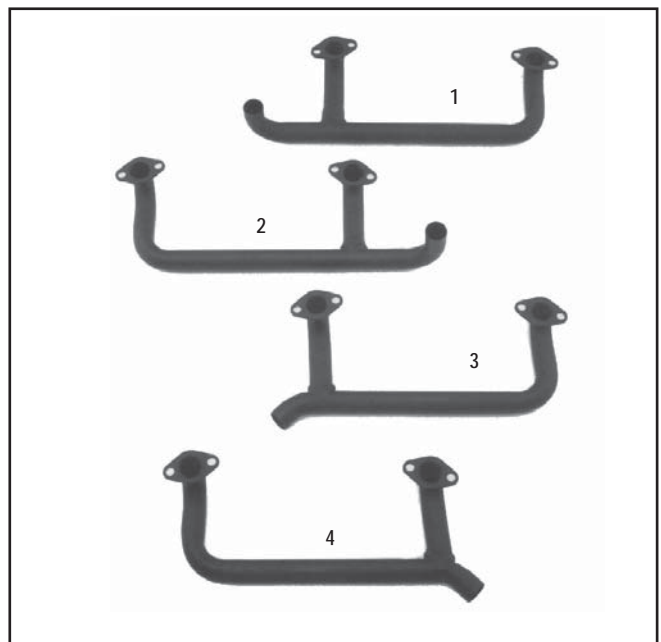

Exhaust

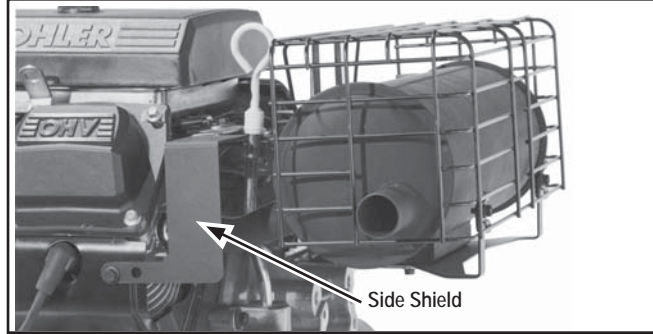
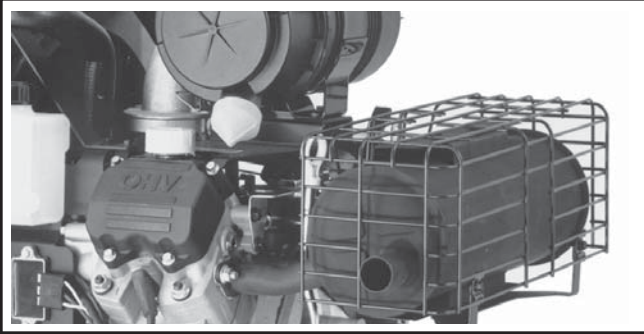

STANDARD PTO-CANISTER MUFFLER & GUARD KITS

(not usable with 1" dia. metal oil fill tube)

| Kit No. | Muff. Only | Outlet Location/Direction | Outlet O.D. | AEGIS | | COMMAND | | Models |
|-----------------|---------------------------|-------------------------------|-------------|-------|-------|---------|-------|-------------------------------|
| | | | | A | B | A | B | |
| 24 786 04-S | 24 068 05-S | Center/Straight | 1.25" | — | — | 4.5" | 10.5" | CH18-22, CH620-680 |
| 24 786 05-S | 24 068 07-S | Filter Side/Straight | 1.25" | — | — | 4.5" | 10.5" | CH18-22, CH620-680 |
| 24 786 06-S | 24 068 06-S | Starter Side/Straight | 1.25" | — | — | 4.5" | 10.5" | CH18-22, CH620-680 |
| 24 786 23-S* | — | Starter Side/45° Down | 1.25" | 4.3" | 10.3" | 4.5" | 10.5" | CH18-25, CH620-730, LH640-755 |
| 24 786 10-S** | 24 068 12-S | Center/Straight | 1.25" | 4.3" | 10.3" | 4.5" | 10.5" | CH25/730,740,750, LH640-755 |
| 24 786 11-S** | 24 068 18-S | Filter Side/Straight | 1.25" | 4.3" | 10.3" | 4.5" | 10.5" | CH25/730,740,750, LH640-755 |
| 24 786 12-S** | 24 068 59-S [§] | Starter Side/Straight (Shown) | 1.25" | 4.3" | 10.3" | 4.5" | 10.5" | CH25/730,740,750, LH640-755 |
| 24 786 26-S | 24 068 57-S [§] | Filter Side/Straight | 1.25" | 4.3" | 10.3" | 4.5" | 10.5" | CH25/730,740,750, LH640-755 |
| 24 755 80-S*** | — | Muffler Guard Kit | — | — | — | — | — | CH18-26/620-750, LH640-775 |
| 24 755 114-S*** | — | Side Shield Kit (2 Shields) | — | — | — | — | — | CH18-26/620-750 only (not LH) |
| 24 786 32-S | 24 068 35-S* [%] | Filter Side/Straight | 1.25" | 4.3" | 10.3" | 4.5" | 10.5" | CH26/745, LH775, ECH630-749 |
| 24 786 33-S | 24 068 41-S* [%] | Center/Straight | 1.25" | 4.3" | 10.3" | 4.5" | 10.5" | CH26/745, LH775, ECH630-749 |
| 24 786 31-S | 24 068 42-S* [%] | Starter Side/Straight | 1.25" | 4.3" | 10.3" | 4.5" | 10.5" | CH26/745, LH775, ECH630-749 |

*CH25,26/730-750,LH640-775 require heat shield. See shields below. **Includes heat shield and screws. See shields below.

***When guard kit 24 755 80-S and shield kit 24 755 114-S are used together, they meet EEC (European) standards for avoidance with hot surfaces.

[%]25 755 36-S mounting kit required for first time installation. [§]Aluminized steel canister.

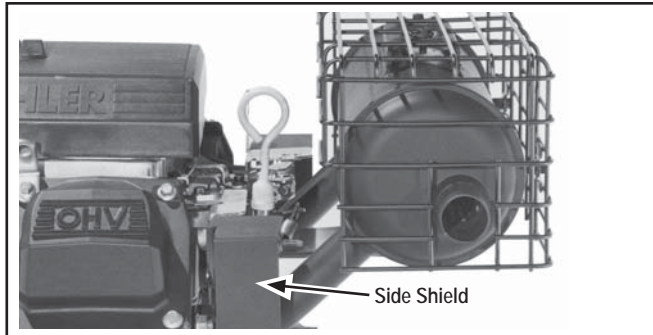
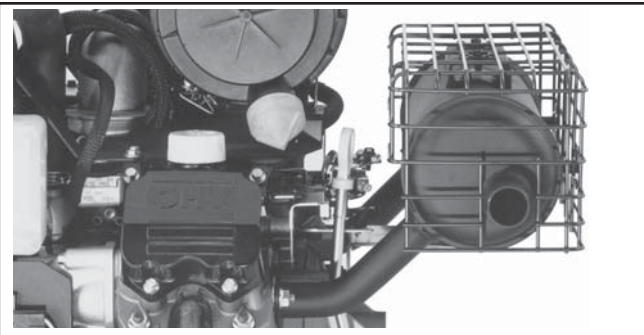

PTO-CANISTER MUFFLER & GUARD KITS (IDEAL FOR GEN SETS)

Mufflers are same size as standard canisters (top of page), but have a raised body to clear the alternator assembly on a generator set. Note that there is no center outlet muffler because it would allow hot exhaust to blow directly at the gen set control box.

| Kit No. | Muff. Only | Outlet Location/Direction | Outlet O.D. | AEGIS | | COMMAND | | Models |
|----------------|-------------|-----------------------------|-------------|-------|-------|---------|--------|--|
| | | | | A | B | A | B | |
| 24 786 21-S* | 24 068 36-S | Filter Side/Straight | 1.25" | 6.3" | 13.1" | 6.5" | 13.25" | CH18-25/620-730,740,750, LH640-755 |
| 24 786 22-S* | 24 068 37-S | Starter Side/Straight | 1.25" | 6.3" | 13.1" | 6.5" | 13.25" | CH18-25/620-730,740,750, LH640-755 |
| 24 786 27-S | 24 068 51-S | Filter Side/Straight | 1.25" | 6.3" | 13.1" | 6.5" | 13.25" | CH26/745, LH775, ECH630-749 |
| — | 24 068 60-S | Starter Side/Straight | 1.25" | 6.3" | 13.1" | 6.5" | 13.25" | CH26/745, LH775, ECH630-749 |
| 24 755 104-S** | — | Muffler Guard Kit | — | — | — | — | — | CH18-25/730-750, LH640-775, ECH630-749 |
| 24 755 114-S** | — | Side Shield Kit (2 Shields) | — | — | — | — | — | CH18-25/730-750 only (not LH) |

* Includes only screws for attaching heat shield. See shields below. (Required for CH25,26/730-750,LH690-775.)

** When guard kit 24 755 104-S and shield kit 24 755 114-S are used together, they meet EEC (European) standards for avoidance with hot surfaces.

A - Centerline of crank to bottom of muffler. B - Centerline of crank to top of muffler.



HEAT SHIELDS FOR CANISTER MUFFLERS

| Part No. | Designed for Mufflers |
|---------------|---|
| 24 314 50-S** | 24 068 12-S, 17-S, 18-S, 36-S, 37-S, 57-S |
| 24 314 21-S** | 24 068 35-S, 41-S, 42-S, 51-S |

* (4) M-650012 screws for mounting heat shield are included in muffler kits, except for 24 786 23-S which requires screws to be ordered.

** Order (4) M-650012-S screws for mounting heat shield.

[§]Aluminized steel to match muffler.



1

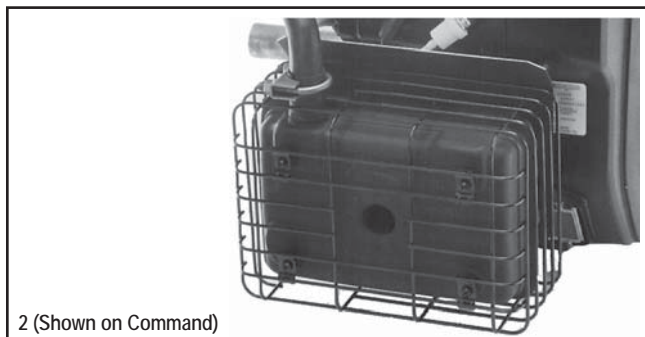

2 (Shown on Command)



3

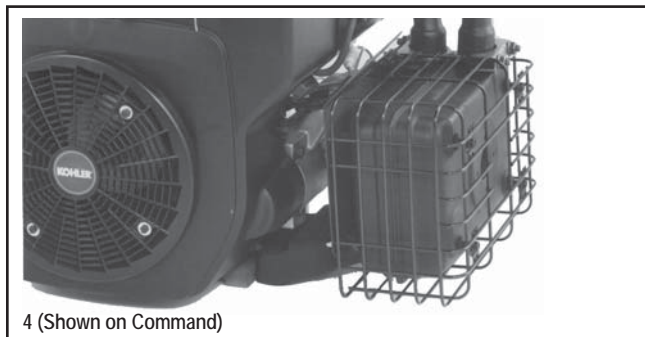

4 (Shown on Command)

SIDE-MOUNT MUFFLER & GUARD KITS (STANDARD)

(not usable with 1" dia. metal or plastic oil fill tube)

| Kit No. | Muff. Only | Location | Outlet D.B.C. | Models | Width By | Extends Engine Item |
|--------------|-------------|-------------------------|---------------|----------------------------------|----------|---------------------|
| 24 786 08-S | 24 068 13-S | Starter Side | 2.047" | CH18-23, 620-680 | 4.0" | 1 |
| 24 786 09-S | 24 068 14-S | Filter Side*** | 2.047" | CH18-23, 620-680* | 4.0" | 1 (Shown) |
| 24 755 22-S | — | Guard Kit** | — | CH18-23, 620-680* | 4.375" | 2 |
| 24 786 19-S | 24 068 30-S | Starter Side | 2.047" | CH25/730,740,750, LH640-755***** | 4.25" | 3 (Shown) |
| 24 786 20-S | 24 068 31-S | Filter Side**** | 2.047" | CH25/730,740,750, LH640-755***** | 5.60" | 3 |
| 24 755 149-S | — | Guard Kit, Starter Side | — | CH25/730-750, LH640-755 | 4.25" | 4 (Shown) |
| 24 755 151-S | — | Guard Kit, Filter Side | — | CH25/730-750, LH640-755 | 5.60" | 4 |
| 24 786 24-S | 24 068 54-S | Starter Side | 2.047" | CH26,745***** | 4.25" | 3 |
| 24 786 25-S | 24 068 55-S | Filter Side**** | 2.047" | CH26,745, LH775***** | 4.25" | 3 |

* Not usable on models with oil cooler.

** Shown on 24 786 09-S Muffler Kit (muffler not included).

*** May also need to order 12 050 01-S oil filter to avoid interference with muffler.

**** Includes 12 050 01-S oil filter to avoid interference with muffler.

***** Kits include muffler and dual manifolds.

SIDE-MOUNT GUARD KITS, EEC (EUROPEAN) COMPLIANT

These kits include guards for the muffler, manifold and exhaust elbow. The guards must be used together to meet EEC standards for avoiding contact with hot surfaces.

| Kit No. | Location | Extends Engine Width By | Models |
|---------------|--------------|-------------------------|-------------------------------|
| 54 755 25-S | Filter Side | 4.375" | CH18-23,620-680 |
| 24 755 150-S* | Filter Side | 4.375" | CH25/730,740,750 LH640-755 |
| 24 755 148-S* | Starter Side | 4.375" | CH25/730,740,750 LH640-755 |

*Manifold guard is metal mesh, compared to wire form in other kits.

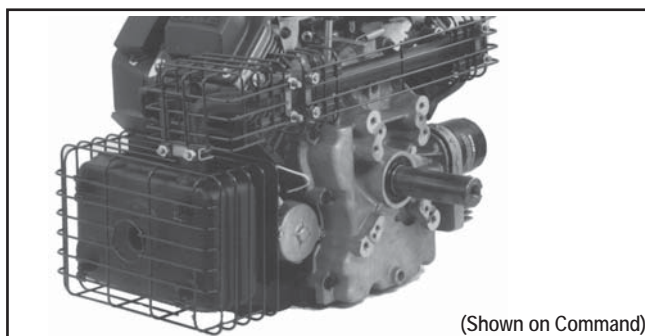

(Shown on Command)

OXYGEN SENSOR FITTING

EFI Repowers

Part No.

25 294 33-S

Exhaust

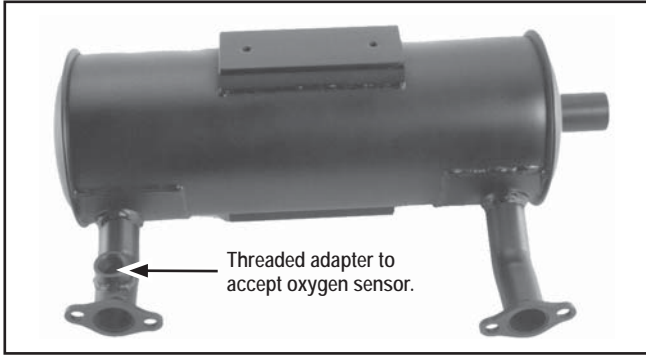

PTO CANISTER MUFFLERS & GUARD (Closed Loop LP Systems)

Mufflers include threaded adapter in filter-side inlet pipe, to accept oxygen sensor for closed loop LP fuel systems.

| Kit No. | Muff. Only | Location/Direction | Outlet O.D. | Models |
|-------------|--------------|-----------------------|-------------|-----------------|
| — | 24 068 33-S* | Starter Side/Straight | 1.25" | CH18-25,620-730 |
| — | 24 068 34-S* | Filter Side/Straight | 1.25" | CH18-25,620-730 |
| 24 755 80-S | — | Wire Guard Kit | — | CH18-25,620-730 |

*Mufflers include brackets for attaching heat shield (required for CH25).
Order 24 314 50-S heat shield and (4) M-650012-S screws.

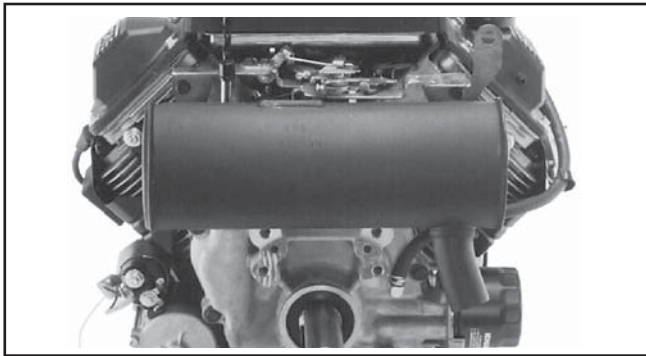

PTO CANISTER MUFFLER (Special Outlet Pointing Down)

Will not accept heat shield or wire guard kit. CARB/EPA compliant on CH18-22 only.

| Part No. | Outlet Direction | Outlet O.D. | Models |
|-------------|------------------|-------------|----------|
| 24 068 11-S | Down | 1.375" | CH18-22* |

*Application Engineering approval needed for CH25/730-740 and LH640-755 due to smaller muffler volume and potential for higher heat.

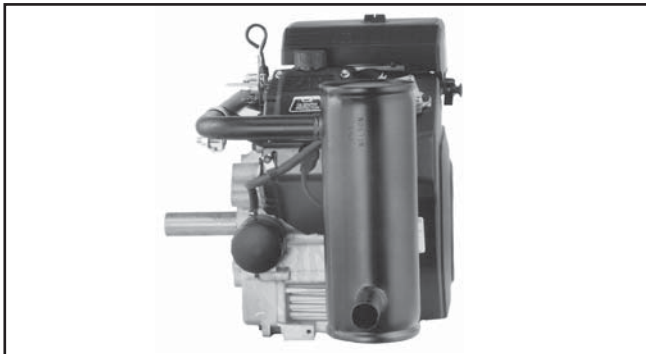

CANISTER MUFFLER (Vertical Orientation)

Available on filter side only (without oil cooler) and as remote. Special shielding is necessary (furnished by customer) to protect the fuel pump. . . whether spec has pulse or mechanical pump. If a mechanical pump is used on starter side, no shielding is necessary.

| Part No. | Mounting Location | Outlet O.D. | Models |
|----------------|---------------------|-------------|-----------------|
| 24 068 15-S* | Remote Mount | 1.375" | CH18-22,620-680 |
| 24 068 16-S** | Filter Side (shown) | 1.375" | CH18-22,620-680 |
| 24 068 48-S*** | Filter Side | — | CH23-740 |

* Also order (1) 24 164 04 manifold, (2) 24 041 49 gasket, and (4) 25 100 52-S nut.

** Same as above, plus: (1) 12 237 02 clamp, (1) M-839020 screw (bracket to crankcase), and (1) M-651030 screw (bracket to valve cover).

* Also order (1) 24 164 27 manifold, (2) 24 041 49 gasket, and (4) 25 100 52-S nut, (1) 12 237 02 clamp, (1) M-839020 screw (bracket to crankcase), and (1) M-651030 screw (bracket to valve cover).

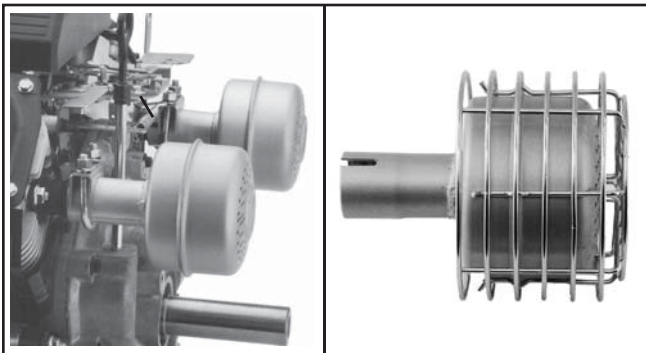

PEPPERPOT MUFFLER & GUARD

Muffler kit includes two mufflers, manifolds and gaskets, plus hardware. Muffler is not usable on engines that must meet CARB/EPA emission regulations, unless approved by Kohler for specific applications.

| Part No. | Muffler Only | Description | Models |
|-------------|--------------|-----------------|------------------------|
| 24 786 07-S | 52 068 04-S | Muffler Kit | CH18-25/730-750, LH640 |
| 25 314 01-S | — | Guard (order 2) | CH18-25/730-750, LH640 |



CROSSOVER MANIFOLDS

| Part No. | Outlet Location | Outlet | Extends From PTO Face | Models | Item |
|-------------------------|--|---------------|-----------------------|-------------------------|------|
| Single Manifolds | | | | | |
| 24 164 04-S | Filter Side | 1.11" (O.D.) | 0.75" Outside Face | CH18-22 | 1 |
| 24 164 02-S | Filter Side (Fits duct package) | 1.11" (O.D.) | 2.125" Outside Face | CH18-22 | 1 |
| 24 164 03-S | Starter Side (Fits duct package) | 1.11" (O.D.) | 2.125" Outside Face | CH18-22 | 1 |
| 24 164 10-S | Starter Side (For side muffler) | 1.11" (O.D.) | 0.25" Inside Face | CH18-22 | 1 |
| 24 164 11-S | Filter Side (For side muffler) | 1.11" (O.D.) | 0.25" Inside Face | CH18-22 | 1 |
| 24 164 27-S**** | Filter Side | 1.24" (O.D.) | 0.25" Inside Face | CH25/730-750, LH640-755 | 1 |
| 24 164 28-S**** | Starter Side | 1.24" (O.D.) | 0.25" Inside Face | CH25/730-750, LH640-755 | 1 |
| 24 164 25-S | Center* | 1.468" (O.D.) | 6.5" Outside Face | CH26/745, LH775 | 2 |
| Dual Manifolds | | | | | |
| 24 164 19-S | Starter Side (For side muffler, cyl. #1)** | 1.26" (I.D.) | 0.25" Inside Face | CH25/730-750, LH640-755 | 3 |
| 24 164 20-S | Starter Side (For side muffler, cyl. #2)** | 1.26" (I.D.) | 0.25" Inside Face | CH25/730-750, LH640-755 | 3 |
| 24 164 21-S | Filter Side (For side muffler, cyl. #2)*** | 1.26" (I.D.) | 0.25" Inside Face | CH25/730-750, LH640-755 | 3 |
| 24 164 22-S | Filter Side (For side muffler, cyl #1)*** | 1.26" (I.D.) | 0.25" Inside Face | CH25/730-750, LH640-755 | 3 |

* Includes port for oxygen sensor (24 418 05-S, not included). To be CARB/EPA certified, must have Kohler Application Engineering approval when non-Kohler exhaust components are used.

** Included in the 24 786 19-S side-mount muffler kit.

*** Included in the 24 786 20-S side-mount muffler kit.

**** Will not fit with straight dipstick tube. Offset dipstick tube or kit 24 755 121-S required.

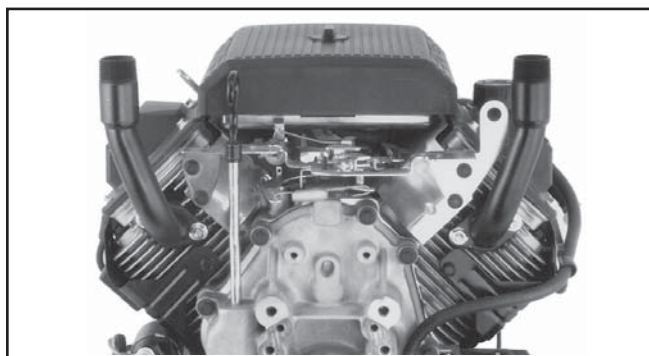

90° MANIFOLD KIT

| Kit No. | Fits Muffler | Thread | Models |
|-------------|--------------|-----------|----------------------------|
| 24 730 01-S | 275679-S | 1" N.P.T. | CH18-25/730-750, LH640-755 |

Kit includes (2) elbows, (2) gaskets, (4) nuts. No interference with PTO face.

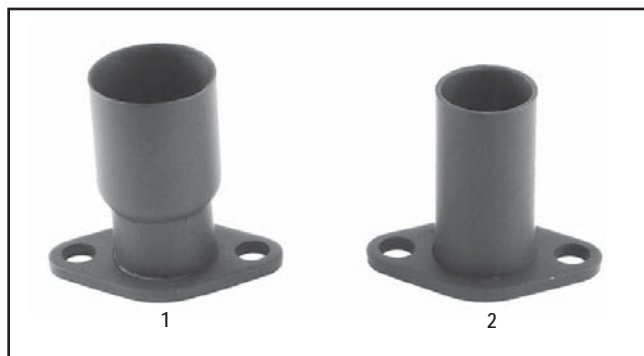

STUB MANIFOLDS

| Kit No. | Outlet O.D. | Models | Item |
|-------------|-------------|----------------------------|------|
| 24 164 05-S | 1.415" | CH18-25/730-750, LH650-775 | 1 |
| 24 164 07-S | 1.125" | CH18-25/730-750, LH650-775 | 2 |



STRAIGHT COUPLE

Use with 90° manifold kit above or other threaded parts.

| Part No. | Description | Thread |
|-------------|-----------------|-----------|
| 24 249 01-S | Straight Couple | 1" N.P.S. |



EXHAUST FLANGE

For adaptation of customer-supplied exhaust.

| Part No. | Description | Models |
|-------------|---------------------|-------------------------------|
| 24 295 01-S | Steel, 0.188" thick | CH/CV17-25/730-750, LH640-775 |



EXHAUST PORT LINER

Offers better thermal protection.

| Part No. | Description | Models |
|-------------|-------------------------------|---|
| 24 605 07-S | Stainless Steel, 0.035" thick | CH/CV17-25/730-750, LH640-775, ECH/ECV630-749 |

*Indicates item not usable on engines which are required to meet CARB or EPA emission regulations, unless approved by Kohler for specific applications.

Exhaust

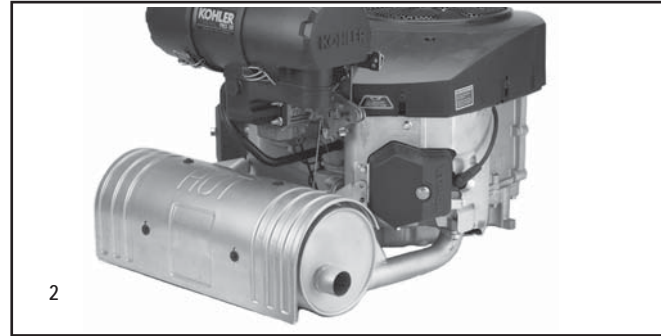
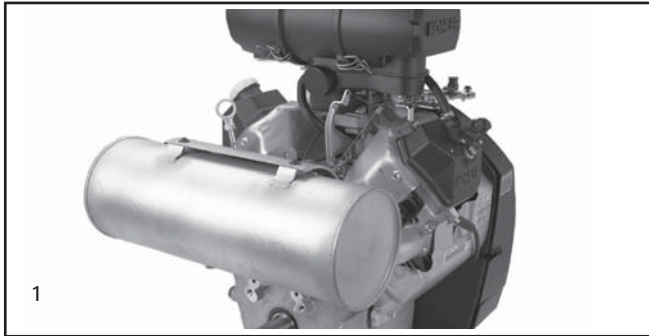

CH940-CH1000 MUFFLER KITS*

| Kit No. | Muff. Only | Discharge | Outlet O.D. | A | B | Item | Heat Shield (required) |
|-------------|-------------|------------------|-------------|--------|------|------|------------------------|
| 62 786 01-S | 62 068 06-S | Center | 1.5" | 11.75" | 4.0" | 1 | 62 314 05-S |
| 62 786 02-S | 62 068 05-S | Starter Side | 1.5" | 11.75" | 4.0" | 1 | 62 314 05-S |
| 62 786 03-S | 62 068 02-S | Opposite Starter | 1.5" | 11.75" | 4.0" | 1 | 62 314 05-S |

*Includes muffler, gaskets, heat shield, and hardware.

A — Centerline of crank to top of muffler.

B — Centerline of crank to bottom of muffler.

TIER III EXHAUST (SAI)

| Part No. | Discharge |
|-------------|--------------------------------|
| 62 068 19-S | Left Outlet (opposite starter) |
| 62 068 27-S | Center Outlet |
| 62 068 28-S | Right Outlet (starter side) |

CV940-CV1000 MUFFLER KITS*

| Kit No. | Muff. Only | Discharge | Outlet O.D. | A | B | Item | Heat Shield (required) |
|-------------|-------------|------------------|-------------|-------|-------|------|------------------------|
| 62 786 04-S | 62 068 09-S | Center | 1.5" | 2.68" | 4.04" | 2 | 62 314 06-S |
| 62 786 05-S | 62 068 08-S | Starter Side | 1.5" | 2.68" | 4.04" | 2 | 62 314 04-S |
| 62 786 06-S | 62 068 07-S | Opposite Starter | 1.5" | 2.68" | 4.04" | 2 | 62 314 04-S |

*Includes muffler, brackets, gaskets, heat shield, and hardware.

A — Mounting surface to bottom of muffler.

B — Mounting surface to top of muffler.

CROSS OVER MANIFOLDS & MUFFLER

Original Equipment Manufacturer responsible for the original installation and thermal protection.

| Kit No. | Models | Description | Location | Outlet O.D. | Inlet I.D. | |
|-------------|------------|-------------|------------------|-------------|------------|--------------|
| 62 164 10-S | CH940-1000 | Manifold | Non-Starter Side | 1.5" | — | Not Pictured |
| 62 164 11-S | CH940-1000 | Manifold | Starter Side | 1.5" | — | Not Pictured |
| 62 068 10-S | CH940-1000 | Muffler | — | — | 1.5" | Not Pictured |



STUB MANIFOLD

| Part No. | Outlet O.D. | Models |
|-------------|-------------|------------|
| 62 164 12-S | 1.5" | CH940-1000 |



EXHAUST FLANGE

| Part No. | Description | Models |
|-------------|--------------------|------------|
| 62 295 01-S | Steel, 0.25" thick | CH940-1000 |

For adaptation of customer-supplied exhaust.

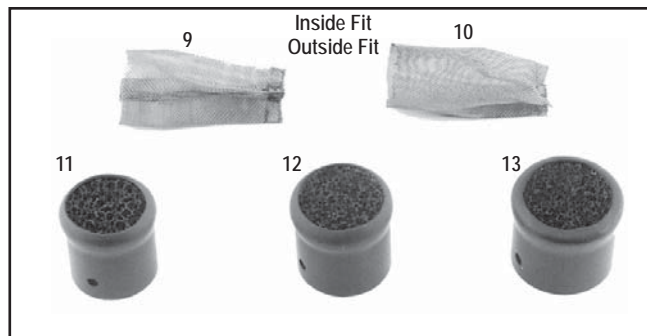
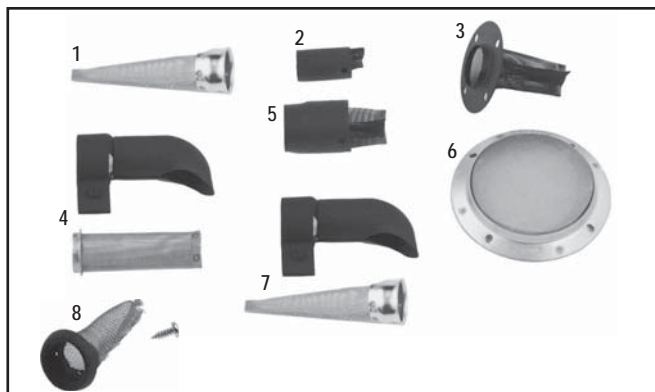

SPARK ARRESTORS

| Part No. | Models | HP Rating For U.S.F.S. | Inlet Size | Fits Muffler Outlet | Mounting D.B.C. | Notes | Item |
|---------------|---|---------------------------|---------------|------------------------|--------------------|---|------|
| 63 189 02-S | CS4-6 | 6 | — | — | — | Already factory-installed on engine | 1 |
| 63 189 01-S | CS8.5-12 | 12 | — | — | — | Already factory-installed on engine | 1 |
| 15 189 01-S | CH6 | 6 | 0.76" I.D. | 0.75" O.D. | — | Includes set screw | 2 |
| 15 755 16-S* | CH6 | 6 | 0.76" I.D. | 0.75" O.D. | — | Kit includes 15 189 01-S arrestor (above) | — |
| 12 189 02-S** | CH/CV11-16/460-493, CH18-25/730-740, LH640-755, SV470-620 | 27 | 1.125" O.D. | 1.126" I.D. | 2.047" | For pillow side muffler | 3 |
| 24 189 01-S | CH18-26/730-750, LH640-775, | 31 | 1.26" I.D. | 1.25" O.D. | — | For canister muffler, inc. deflector | 4 |
| 25 189 01-S | CH/CV11-16/460-493, CH18-26/730-750, LH640-775 | 27 | 1.26" I.D. | 1.25" O.D. | — | Includes set screw | 5 |
| 25 189 02-S | CH/CV17-26/730-750, LH640-775, LV625-680 | 27 | 1.39" I.D. | 1.375" O.D. | — | Includes set screw | 5 |
| 25 533 01-S** | CH11-15 | 23 | — | — | 3.68" | For 275679-S pepperpot muffler | 6 |
| 62 189 02-S | CH940-1000 | 40 | — | — | — | Includes set screw | — |
| 62 533 01-S | CH940-1000 | 40 | — | — | — | For canister muffler, inc. deflector | 7 |
| 14 533 01-S | XT-6/7 | 27 | — | — | — | Already factory-installed on engine | 8 |
| 17 533 09-S | CH270 | 27 | — | — | — | Already factory-installed on engine | 3 |

* User must weld adapter to muffler outlet. Other end will then accept 15 189 01-S arrestor. Also must cut slot in guard.

** Also order (4) M-545010-S screw (drill 5/32" holes in muffler).

EXHAUST SILENCERS

| Part No. | Models | HP Rating For U.S.F.S. | Inlet Size | Fits Muffler Outlet | Notes | Item |
|-------------|-----------------------|---------------------------|---------------|------------------------|-----------------------|------|
| 52 428 01-S | Varies by outlet size | **** | — | 1.375" O.D. | Use 52 086 20-S screw | 9 |
| 12 755 35-S | Varies by outlet size | **** | — | 1.25" O.D. | Includes screw | 10 |
| 25 755 08-S | Varies by outlet size | **** | — | 1.25" O.D. | Includes screw | 11 |
| 25 755 09-S | Varies by outlet size | **** | — | 1.375" O.D. | Includes screw | 12 |
| 25 755 10-S | Varies by outlet size | **** | — | 1.5" O.D. | Includes screw | 13 |

****Not U.S.F.S. approved.

Exhaust

EXHAUST DEFLECTORS

| Part No. | Models | Inlet I.D. | Fits Muffler Outlet | Also Order | Item |
|---------------|--|------------|---------------------|------------|------|
| 45 054 21-S | CH/CV17-26/730-750, LH640-775, LV625-680 | 1.376" | 1.375" O.D. | D | 1 |
| 25 054 05-S | CH/CV940-1000, | 1.55" | 1.50" O.D. | D | 1 |
| 12 054 02-S | CV11-16/460-493, CH18-26/730-750, LH640-775 | 1.26" | 1.25" O.D. | B | 2 |
| 24 265 06-S | CH/CV17-26/730-750, LH640-775, LV625-680 | 1.39" | 1.375" O.D. | B | 3 |
| 24 265 07-S | CS8.5 (300cc), CS10-12, CH/CV17-26/730-750, LH640-775, LV625-680 | 1.39" | 1.375" O.D. | B | 4 |
| 63 265 01-S | CS4-6 | 1.02" | 1.0" | E | 5 |
| 63 265 02-S | CS8.5 (250cc) | 1.96" | 1.94" O.D. | E | 5 |
| 24 265 01-S | CH/CV11-16/460-493, CH18-26/730-750, LH640-775 | 1.25" | 1.25" O.D. | — | 6 |
| 15 265 02-S | CH6 | — | 1.57" D.B.C. | A | 7 |
| 12 755 106-S* | CH/CV11-16/460-493, CH18-25/730-740**, LH640-755, SV470-620 | — | 2.047" D.B.C. | — | 8 |
| 12 755 28-S* | CH/CV11-16/460-493, CH18-25/730-740, LH640-755, SV470-620 | — | 2.047" D.B.C. | — | 9 |
| 25 755 19-S* | CH/CV11-16/460-493, CH18-25/730-740, LH640-755, SV470-620 | — | 2.047" D.B.C. | — | 10 |
| 24 755 49-S* | CH/CV17-750 | — | 3.06" D.B.C. | — | 11 |
| 24 755 168-S* | CH/CV17-750 | — | 3.06" D.B.C. | — | 12 |
| 62 265 03-S | CH940-1000 | — | 1.50" O.D. | — | — |
| 18 730 01-S | SH265 | — | — | — | 13 |
| 17 730 05-S | CH270 | — | 2.01" D.B.C. | — | 14 |
| 17 730 03-S | CH395/440 | — | 2.05" D.B.C. | — | 15 |

SHIELD KITS

| Part No. | Models | Inlet I.D. | Fits Muffler Outlet | Item |
|-------------|--------|------------|---------------------|------|
| 17 730 01-S | CH270 | — | 2.01" D.B.C. | 16 |
| 17 730 02-S | CH395 | — | 2.05" D.B.C. | 17 |

PIPE PROTECTORS

| Part No. | Models | Inlet I.D. | Fits Muffler Outlet | Item |
|-------------|--------|------------|---------------------|------|
| 17 730 04-S | CH440 | — | — | 18 |
| 17 730 06-S | CH270 | — | — | 19 |
| 17 730 08-S | CH395 | — | — | 20 |

*Kit includes deflector, screws.

**Minor modifications are needed to muffler guard 24 755 22-S if deflector is used with it.

A — (2) M-556010-S Screw

B — (1) 47 237 04-S Clamp

D — (1) 24 237 13-S Clamp

E — (1) 25 086 46-S Screw

C — (1) 25 086 40-S Screw

HARDWARE KITS

For attaching mufflers to exhaust outlets.

| Kit No. | Models | Includes | Item |
|-------------|--|--------------------|------|
| 12 786 17-S | CH/CV11-16/460-493 | 2 nuts, 1 gasket | 1 |
| 25 786 01-S | CH18-26/730-750, LH630-775, TH520-575 w/standard flange nuts (shown) | 4 nuts, 2 gaskets | 2 |
| 17 786 01-S | CH270 | 3 screws, 1 gasket | 3 |
| 17 786 02-S | CH395/440 | 3 screws, 1 gasket | 3 |

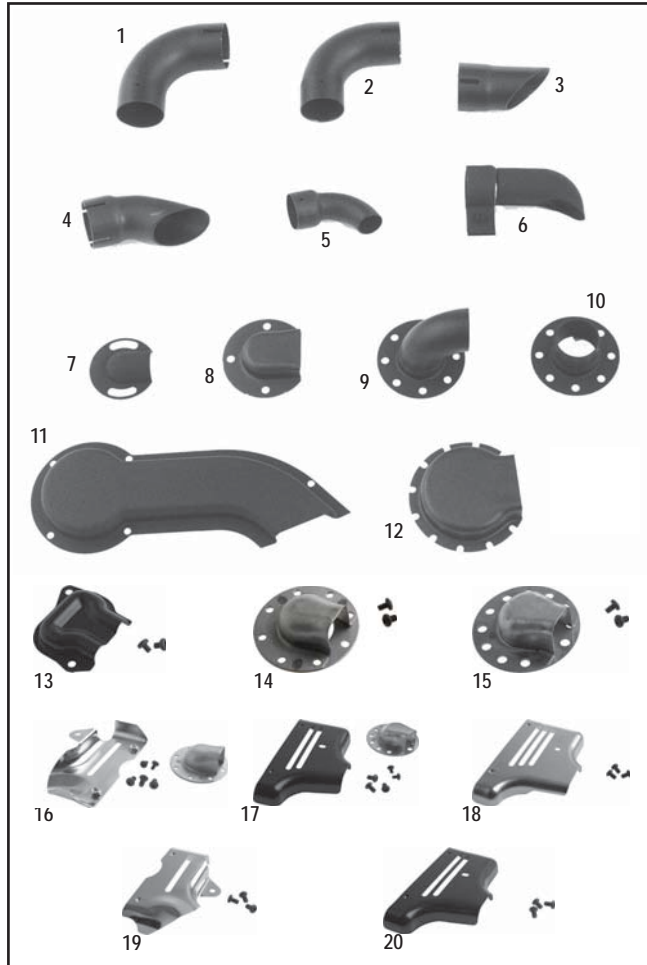

Courage® Single



Silver Graphics
14 113 02-S for XT-7
14 113 12-S for XT-6



Primer Decal
14 113 04-S

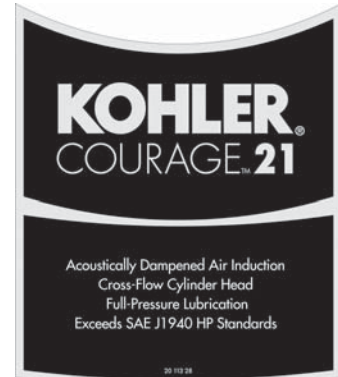

Silver letters/numbers
20 113 09-S - 15 HP
20 113 10-S - 16 HP
20 113 11-S - 17 HP
20 113 12-S - 18 HP
20 113 13-S - 19 HP
20 113 14-S - 20 HP
20 113 28-S - 21 HP
20 113 38-S - 22 HP



Silver letters/numbers
20 113 29-S (fixed guard)

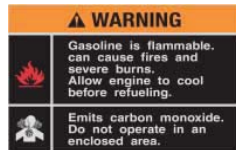

Warning Decal
14 113 03-S

Courage® Twin



Silver letters/numbers
32 113 02-S - 20 HP
32 113 03-S - 23 HP
32 113 04-S - 25 HP
32 113 24-S - 26 HP
32 113 05-S - 27 HP



Silver letters/numbers
32 113 06-S - 20 HP
32 113 12-S - 22 HP
32 113 07-S - 23 HP
32 113 08-S - 25 HP
32 113 25-S - 26 HP
32 113 09-S - 27 HP



Silver letters/numbers
32 113 10-S wing set



Silver letters/numbers
32 113 11-S - (fixed guard)
Gold letters/numbers
32 113 53-S - (fixed guard)

(Note: All labels shown smaller than actual size.)

Labels

Aegis®

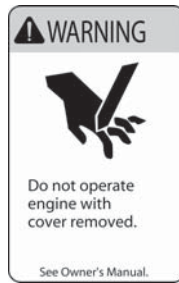

66 113 01-S

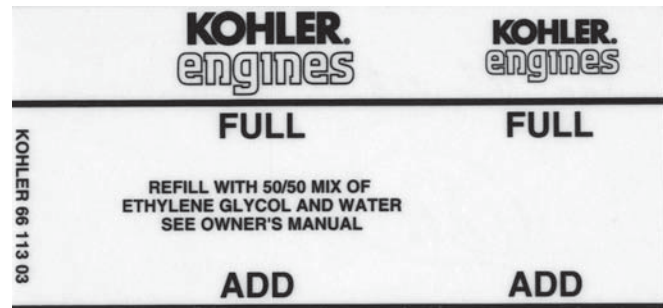

Black on clear, coolant bottle level
66 113 03-S

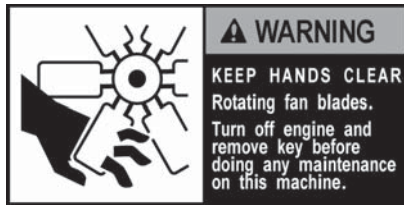

66 113 04-S



Matte gold letters/numbers, blue stripe

66 113 14-S – 24 HP

66 113 07-S – 25 HP

66 113 15-S – 26 HP

66 113 16-S – 28 HP

66 113 17-S – 31 HP (EFI)

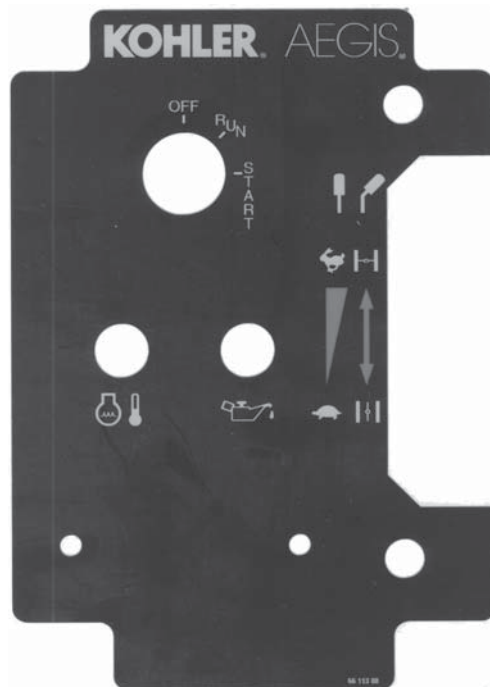

66 113 08-S

(Note: All labels shown smaller than actual size.)

Command PRO CS® Single



Gold letters/numbers

63 113 08-S – 4 HP
63 113 12-S – 6 HP
63 113 13-S – 8.5 HP
63 113 14-S – 10 HP
63 113 05-S – 12 HP
63 113 33-S – 12.75 HP



Gold letters/numbers
63 113 32-S



Gold letters/numbers
63 113 25-S

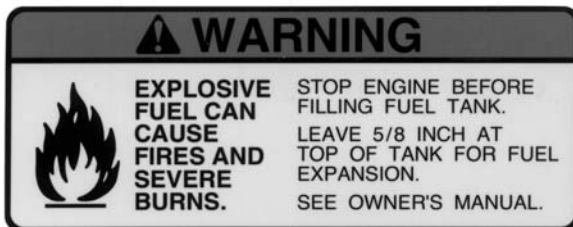

63 113 06-S (All HP)



63 113 11-S – Recoil (4, 6 HP)
63 113 04-S – Recoil (8.5, 10, 12 HP)



Gold letters/numbers
63 113 18-S – 6 HP (2.5" dia.)
63 113 19-S – 8.5 HP (3.25" dia.)
63 113 20-S – 10 HP (3.25" dia.)
63 113 21-S – 12 HP (3.25" dia.)

(Note: All labels shown smaller than actual size.)



63 113 10-S – Choke (4, 6 HP)



63 113 02-S – Choke (8.5/300cc, 10, 12 HP)



63 113 01-S – Speed (4-6, 8.5/300cc 10, 12 HP)



63 113 23-S – Speed/Choke (8.5/250cc HP)



63 113 16-S – Ignition (4, 6 HP)



63 113 26-S – Ignition (8.5/250cc HP)



63 113 15-S – Ignition (8.5/300cc, 10, 12 HP)

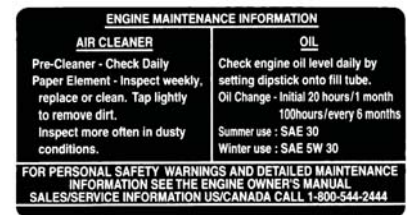

63 113 03-S (All HP)



Gold letters/numbers
66 113 31-S (3.25" dia.)



63 113 24-S
(4-6,8.5-12 HP, H.D. Air Cleaner)

Labels

Command® Single

ENGINE MAINTENANCE INFORMATION

| | |
|---|--|
| AIR CLEANER PRECLEANER—CHECK DAILY PAPER ELEMENT—INSPECT WEEKLY. REPLACE OR CLEAN. TAP LIGHTLY TO REMOVE DIRT. INSPECT MORE OFTEN IN DUSTY CONDITIONS. | OIL/OIL FILTER CHECK ENGINE OIL LEVEL DAILY BY SETTING DIPSTICK ONTO TUBE. OIL CHANGE – 100 HOURS/ONCE A SEASON. SUMMER—USE SAE 10W30 WINTER—USE SAE 5W30 OIL FILTER CHANGE—200 HOURS/ EVERY OTHER OIL CHANGE. |
|---|--|

FOR PERSONAL SAFETY WARNINGS AND DETAILED MAINTENANCE INFORMATION, SEE THE ENGINE OWNER'S MANUAL.
SALES SERVICE INFORMATION US CANADA CALL 1-800-544-2444

12 113 04 (6-88)

12 113 04-S (100 hr. oil interval, summer 10W-30)

ENGINE MAINTENANCE INFORMATION

| | |
|---|---|
| AIR CLEANER PRECLEANER—CHECK DAILY PAPER ELEMENT—INSPECT WEEKLY. REPLACE OR CLEAN. TAP LIGHTLY TO REMOVE DIRT. INSPECT MORE OFTEN IN DUSTY CONDITIONS. | OIL/OIL FILTER CHECK ENGINE OIL LEVEL DAILY BY SETTING DIPSTICK ONTO TUBE. OIL CHANGE – 50 HOURS/ONCE A SEASON. SUMMER—USE SAE 10W30 WINTER—USE SAE 5W30 OIL FILTER CHANGE—100 HOURS/ EVERY OTHER OIL CHANGE. |
|---|---|

FOR PERSONAL SAFETY WARNINGS AND DETAILED MAINTENANCE INFORMATION, SEE THE ENGINE OWNER'S MANUAL.

12 113 53 (NOV 93)

12 113 53-S (50 hr. oil interval)

STARTING INSTRUCTIONS

1. PLACE THROTTLE IN CHOKE POSITION.
2. SLOWLY PULL STARTER HANDLE UNTIL JUST PAST COMPRESSION - STOP! RETURN STARTER HANDLE, PULL FIRMLY TO START.

USE SAE 10W30 OIL.
USE OF HEAVIER OIL WILL MAKE STARTING DIFFICULT.

12 113 07-S (Starting)

WARNING

EXPLOSIVE FUEL CAN CAUSE FIRES AND SEVERE BURNS.

STOP ENGINE BEFORE FILLING FUEL TANK.
LEAVE 1 1/4 INCH AT TOP OF TANK FOR FUEL EXPANSION.
SEE OWNER'S MANUAL.

12 113 21-S

STARTING INSTRUCTIONS

1. PLACE THROTTLE IN CHOKE POSITION.
2. SLOWLY PULL STARTER HANDLE UNTIL JUST PAST COMPRESSION - STOP! RETURN STARTER HANDLE, PULL FIRMLY TO START.

STOPPING INSTRUCTIONS

1. MOVE THROTTLE TO MID-RANGE BEFORE STOPPING.
USE SAE 10W30 OIL.
USE OF HEAVIER OIL WILL MAKE STARTING DIFFICULT.

12 113 71-S (Starting/Stopping)



12 113 16-S – white on clear



12 113 22-S – white on clear



12 113 50-S



12 113 17-S – white on clear



Non-PRO, silver on black, red stripe
12 113 42-S – 14 HP
12 113 118-S – 17 HP
12 113 119-S – 18 HP



PRO, matte gold letters/numbers, red stripe
12 113 108-S – 11 HP
12 113 109-S – 12.5 HP
12 113 110-S – 13 HP
12 113 112-S – 15 HP
12 113 120-S – 15.5 HP
24 113 94-S – 18 HP

(Note: All labels shown smaller than actual size.)

Command® Twin



Non-PRO, silver on black, red stripe

- | | |
|----------------------|--------------------------------|
| 24 113 134-S – 16 HP | 24 113 71-S – 22 HP |
| 24 113 11-S – 18 HP | 24 113 130-S – 23 HP |
| 24 113 33-S – 19 HP | 24 113 131-S – 25 HP |
| 24 113 102-S – 21 HP | 24 113 137-S – 26 HP (non-EFI) |
| 24 113 129-S – 20 HP | 24 113 132-S – 27 HP |
| | 24 113 133-S – 28 HP |



PRO, matte gold letters/numbers, red stripe

- | | |
|---------------------|----------------------------|
| 24 113 93-S – 17 HP | 24 113 97-S – 25 HP |
| 24 113 94-S – 18 HP | 24 113 100-S – 26 HP (EFI) |
| 24 113 95-S – 20 HP | 24 113 124-S – 27 HP |
| 24 113 96-S – 22 HP | 24 113 125-S – 28 HP (EFI) |
| 24 113 90-S – 23 HP | 24 113 143-S – 30 HP |



PRO, matte gold letters/numbers, green stripe and EFI

- | | |
|----------------------|----------------------|
| 24 113 154-S – 25 HP | 24 113 155-S – 29 HP |
| 24 113 153-S – 27 HP | |



PRO, matte gold letters/numbers, green stripe and EFI

- | | |
|----------------------|----------------------|
| 24 113 161-S – 19 HP | 24 113 164-S – 25 HP |
| 24 113 162-S – 21 HP | 24 113 165-S – 27 HP |
| 24 113 163-S – 23 HP | 24 113 166-S – 29 HP |



PRO, matte gold on black
25 113 24-S – 1.625" dia.
25 113 25-S – 2.5" dia.



Non-PRO, silver on black, red circle
24 113 18-S – 1.75" dia.



Black on silver, high-temperature material - rear of flat A/C

- | | |
|----------------------|------------------------------------|
| 24 113 99-S – 17 HP | 24 113 24-S – 22 HP |
| 24 113 07-S – 18 HP | 24 113 89-S – 23 HP |
| 24 113 08-S – 20 HP | 24 113 34-S – 25 HP |
| 24 113 150-S – 21 HP | 24 113 138-S – Plain Silver, no HP |

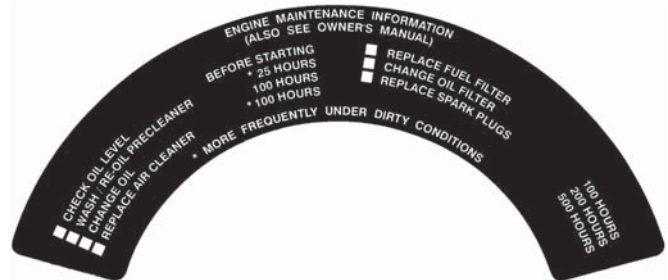

24 113 31-S



- | |
|---------------------|
| 24 113 19-S – 18 HP |
| 24 113 20-S – 20 HP |
| 24 113 51-S – 25 HP |

(Note: All labels shown smaller than actual size.)

Command® Twin

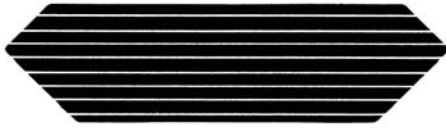

24 113 05-S – Red Stripes
24 113 58-S – Gold Stripes

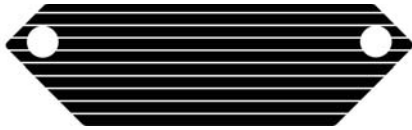

24 113 103-S – Gold Stripes

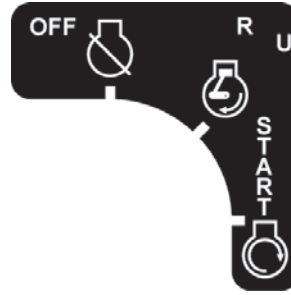

24 113 126-S
For CH Twins with plastic
intake manifold.



24 113 03-S
For CH Twins with aluminum
intake manifold.

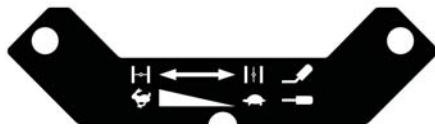

24 113 92-S – New choke/throttle w/o Oil Sentry™



24 113 45-S

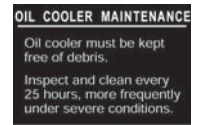

24 113 25-S



24 113 91-S – New choke/throttle w/Oil Sentry™

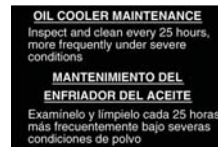

24 113 145-S



24 113 14-S



24 113 127-S – New choke w/o Oil Sentry™



24 113 06-S – Old choke/throttle
w/o Oil Sentry™



24 113 78-S



24 113 04-S – Old choke/throttle
w/Oil Sentry™



24 113 15-S – Old choke

(Note: All labels shown smaller than actual size.)

All Models



25 113 05-S (white on clear)

THIS ENGINE DOES NOT COMPLY WITH FEDERAL OR CALIFORNIA SMOG ON HIGHWAY EMISSION REQUIREMENTS. SALE OR INSTALLATION OF THIS ENGINE FOR ANY PURPOSE OTHER THAN AS A REPLACEMENT ENGINE FOR A LIKE OFF-ROAD UNCERTIFIED ENGINE IS A VIOLATION OF FEDERAL AND CALIFORNIA LAW SUBJECT TO CIVIL PENALTY.

25 113 28-S

STARTING INSTRUCTIONS
THIS UNIT IS EQUIPPED WITH AN ELECTRIC FUEL PUMP. IF IT HAS NOT BEEN OPERATED WITHIN THE LAST 24 HOURS, TURN THE KEY SWITCH TO THE "ON/RUN" POSITION AND WAIT FOR 5 SECONDS BEFORE ATTEMPTING TO START THE ENGINE.

25 113 18-S

ENGINE MAINTENANCE INFORMATION
INFORMACION DEL MANTENIMIENTO DEL MOTOR

AIR CLEANER
WEEKLY - CHECK AIR CLEANER ELEMENT AND FILTER BLOWER GAUGE.
IF SO EQUIPPED - SERVICE ACCORDINGLY.
INSPECT MORE OFTEN IN DUSTY CONDITIONS.

FILTER DE AIRE
SEMANAL - REVISAR EL FILTRO DE AIRE Y EL SENSOR DE BOMBEO DE FILTRACION. INSPECCIONAR LA BOMBA DE FILTRACION SI ESTE EQUIPO TIENE ESTE EQUIPO.
REVISAR MAS FRECUENTE EN CONDICIONES POLVICOSAS.

WINTER - USE SAE 10W30
OIL FILTER CHANGE 200 HOURS

VERANO - USE SAE 10W30
OIL FILTER CHANGE 200 HORAS

FOR PERSONAL SAFETY WARNINGS AND DETAILED MAINTENANCE INFORMATION, SEE PRODUCT OWNER'S MANUALS.
PARA ADVERTENCIAS DE SEGURIDAD PERSONAL, E INFORMACION DETALLADA DEL MANTENIMIENTO, CONSULTE EL MANUAL DEL PROPIETARIO DEL MOTOR.

25 113 44-S

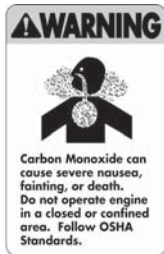

25 113 32-S



25 113 23-S

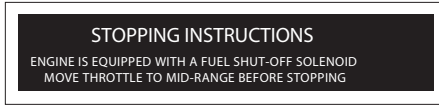

25 113 17-S

ENGINE MAINTENANCE INFORMATION

AIR CLEANER
WEEKLY - CHECK AIR CLEANER ELEMENT AND FILTER BLOWER GAUGE.
IF SO EQUIPPED - SERVICE ACCORDINGLY.
INSPECT MORE OFTEN IN DUSTY CONDITIONS.

OILS, GREAS
CHECK ENGINE OIL LEVEL DAILY BY SETTING DIPSTICK. OILS: THE CHANGE 100 HOURS/ONCE A SEASON.
SUMMER - USE SAE 10W30
WINTER - USE SAE 5W30
OIL FILTER CHANGE 200 HOURS EVERY OTHER OIL CHANGE.

FOR PERSONAL SAFETY WARNINGS AND DETAILED MAINTENANCE INFORMATION, SEE THE PRODUCT OWNER'S MANUALS.
SALES SERVICE INFORMATION US/CANADA CALL 1-800-544-2444

25 113 27-S - H.D. air cleaner

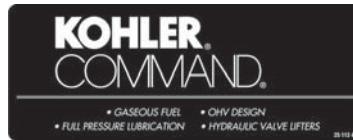

25 113 42-S



41 037 10-S Write-on w/clear protective overlay



25 113 39-S (clear overlay for name plate)



PRO[®], matte gold on black
25 113 24-S - 1.625" dia.
25 113 25-S - 2.5" dia.



25 113 33-S

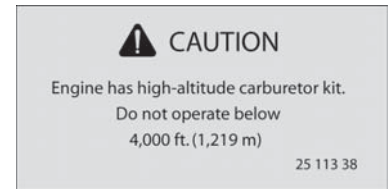

25 113 38-S



25 113 51-S (black on clear)
25 113 50-S (white on clear)

(Note: All labels shown smaller than actual size.)

Hang Tags and Cards

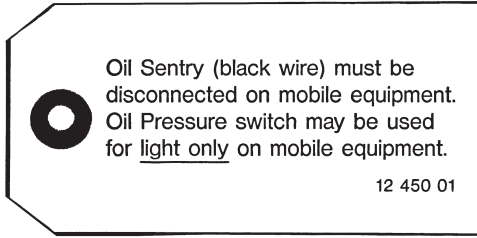

12 450 01-S



25 450 07-S

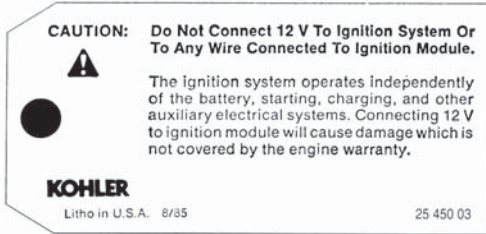

25 450 03-S

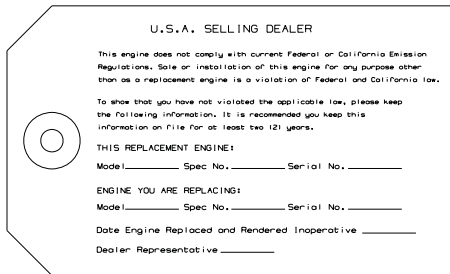

25 450 09-S

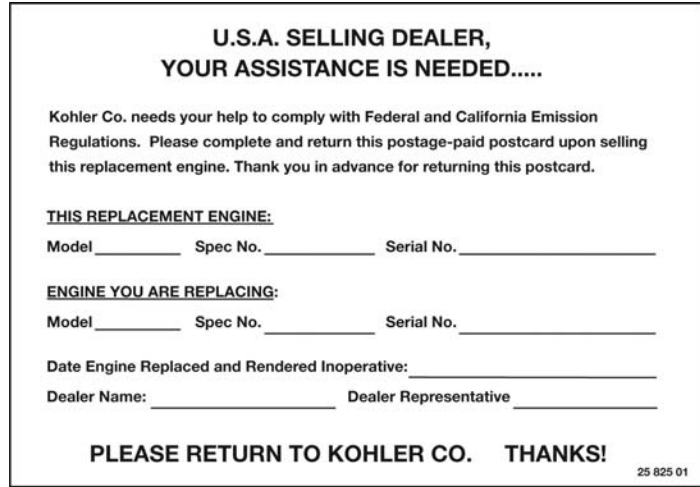

Back Side



25 450 05-S



Front Side
 25 825 01-S

(Note: All hang tags shown smaller than actual size.)

HERITAGE // KOHLER POWERS THE EARTH.

Nearly a century ago, the first KOHLER® engines worked sunup to sundown on American farms. Now they power hard-working equipment for construction, power washing, welding, lawn and landscape, and yes - agriculture.

From the world's first four-cycle, water-cooled gas engine in 1920 to the diesel engines we developed for the U.S. Navy in WWII to the industry's first electronic fuel-injected engine, we've built our reputation on high-quality engines that get the job done. Every time.

DURABILITY // BUILT FOR THE LONG HAUL.

We know the torture you put an engine through. Sixteen-hour days. Punishing weather. Monster inclines. So we make sure it lasts. Every engine is Kohler-engineered and extensively tested using stringent Kohler quality criteria.

You rely on us to make a living. We won't let you down.

PARTS & SERVICE // WE'VE GOT YOUR BACK.

We stand behind our dealers, and they stand behind our warranty. It's customer first, every time. Need a replacement part? It's in stock now, period. There are 13,000 dealers in our service network, so if yours doesn't have it, he'll get it in 48 hours or less.

KOHLER GENUINE PARTS

Only Kohler Engines makes genuine parts for KOHLER engines. They're built for the long haul. And designed to give you peace of mind.



For more information, contact your KOHLER source of supply. Or call toll-free in the U.S. and Canada 800-544-2444.

Kohler Co., Kohler, Wisconsin 53044 Tel 920-457-4441 Fax 920-459-1570

KohlerEngines.com

© 2013 by Kohler Co. All rights reserved.

KOHLER Engines

Printed in U.S.A. 25 800 148 REVA 6/13