

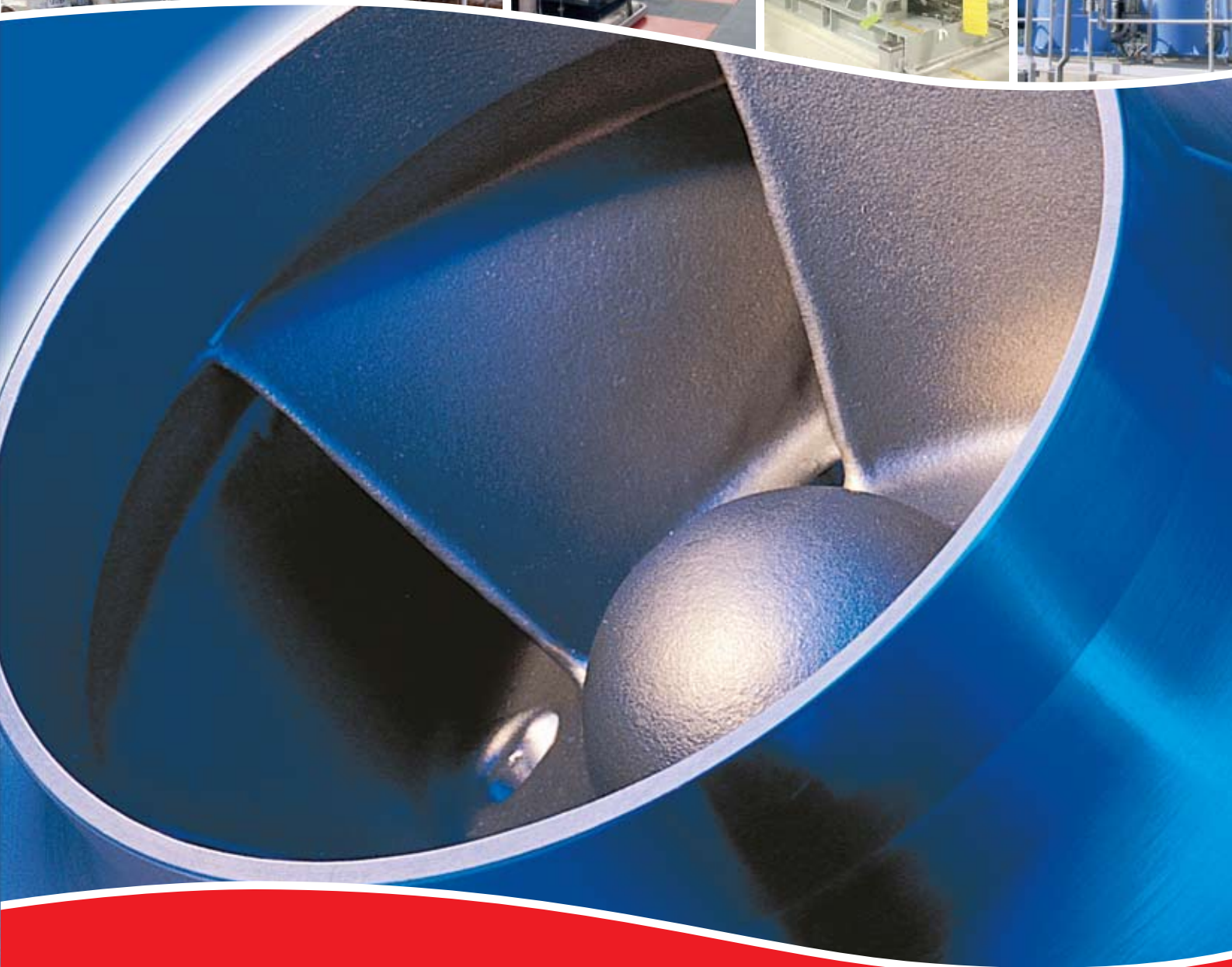

Pump Product Catalog



Experience In Motion



Pump Supplier to the World

Flowserve is the driving force in the global industrial pump marketplace. No other pump company in the world has the depth or breadth of expertise in the successful application of pre-engineered, engineered and special purpose pumps and systems.



Product Brands of Distinction

AGEC™ Centrifugal Pumps

Aldrich® Pumps

Byron Jackson® Pumps

Calder™ Energy Recovery Devices

Cameron® Pumps

Durco® Pumps

Flowserve® Pumps

IDP® Pumps

Jeumont-Schneider™ Pumps

Niigata Worthington™ Pumps

Pacific® Pumps

Pleuger® Pumps

Scienco® Pumps

Sier-Bath® Rotary Pumps

TKL™ Pumps

United® Centrifugal Pumps

Western Land Roller® Irrigation Pumps

Wilson-Snyder® Pumps

Worthington® Pumps

Worthington Simpson® Pumps



Pump Designs

Flowserve offers a wide range of complementary pump types, built to recognized global standards and customer specification. These include:

- Single stage process
- Between bearings single stage
- Between bearings multistage
- Vertical
- Submersible motor
- Positive displacement
- Nuclear
- Specialty

Available Configurations

- Sealed and sealless
- Axially and radially split
- Volute and diffuser
- Close coupled and spacer coupled
- Single and double case



Committed to the Complete Pump System Life Cycle

For more than two centuries, Flowserve has served industries requiring solutions that add value and reduce costs throughout the life cycle of a pumping system.

- Oil and gas
- Chemical
- Power generation
- Water
- General industry

Flowserve partners with customers to respond to the dynamic business conditions that affect them and to improve efficiency, maximize throughput and control process quality. Whether customer needs involve on-site technical assistance, equipment upgrades or broader project planning with full turnkey responsibility, Flowserve delivers professional, reliable results.





A Guide to Flowserve Pumps

The purpose of this publication is to provide a brief summary of the hundreds of pumps which comprise the Flowserve product line. Pump models are divided into five sections, beginning with overhung pumps and continuing through specialty designs. Each pump is identified by its formal designation and accompanied by a full-color cutaway illustration. Applicable engineering standards are listed along with performance characteristics and key features. The symbols shown at right are used to identify each pump's primary market applications.

For more information about Flowserve pumps, visit:
www.flowserve.com



Oil and Gas



Chemical



Power



Water Resources



Mining



Pulp and Paper



Primary Metals



General Industry

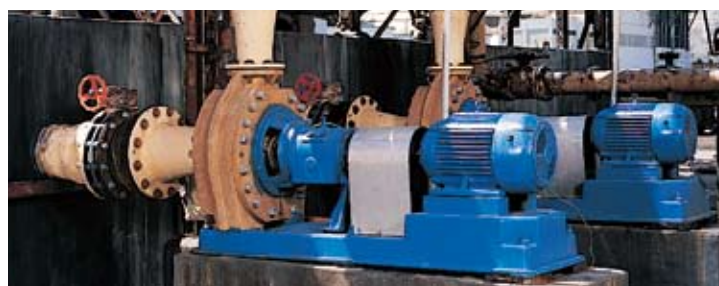

Table of Contents

Pump Selection Guide6-7

Overhung Pumps

Product List 9
 Chemical Process 10-15
 API Process 16-18
 Slurry and Solids Handling 19-22
 Industrial Process 23-25

Between Bearings Pumps

Product List 27
 Single Case - Axially Split - Single Stage 28-29
 Single Case - Axially Split - Multistage 30
 Single Case - Radially Split - Single Stage 31
 Single Case - Radially Split - Multistage 32-34
 Double Case 35-37

Vertical Pumps

Product List 39
 Wet Pit 40-41
 Double Case 42-43
 Submersible 44
 Slurry and Solids Handling 45-47
 Sump 48-49

Positive Displacement

Product List 51
 Gear 52
 Screw 53
 Reciprocating 54

Specialty Products

Product List 57
 Nuclear Pumps and Seals 58-61
 Extreme Temperature Pumps 62
 Others 63-65

Additional Information

Introduction 67
 Integrated Solutions Group 68-69
 Other Flowserve Products 70
 Reference Sources 71

Index

Product List 72-73



Overhung Pumps

Chemical Process

Mark 3 ASME Standard	10
Mark 3 Lo-Flo	10
Mark 3 Unitized Self-Primer	10
Mark 3 Recessed Impeller	11
Mark 3 In-Line	11
Guardian Magnetic Drive	11
CPX3 ISO Standard	12
CPX3 Self-Priming	12
CPX3 Recessed Impeller	12
CPX3 Close Coupled	13
CPXV Chemical Sump	13
CPXS Magnetic Drive	13
PolyChem GRP	14
PolyChem VGRP	14
PolyChem S-Series	14
PolyChem M-Series	15
Polyshield	15
Polybase	15

API Process

HPX	16
HPXM	16
PHL	16
ERP/N	17
PVXM	17
HWMA	17
PVML	18
MSP	18
DSVP	18

Slurry and Solids Handling

M	19
R	19
Titan Slurry	19
LC	20
MND	20
MNR	20
FRBH	21
FRBHJC	21
MPT	21
MF	22
MN	22
MSX	22

Industrial Process

D800	23
MEN	23
MENBLOC	23
ME	24
DS	24
SMP	24
SMX	25
F-Line	25
MVE	25



Mark 3 ASME Standard

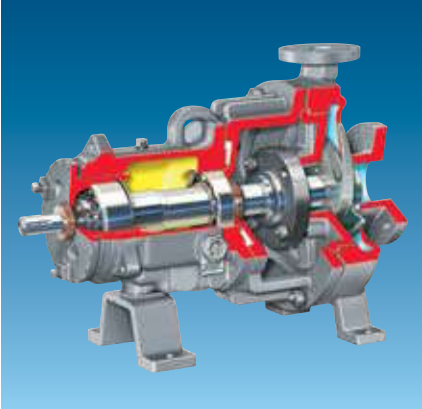

Standards

- ASME (ANSI) B73.1

Operating Parameters

- Flows to 1680 m³/h (7400 gpm)
- Heads to 215 m (700 ft)
- Pressures to 27 bar (400 psi)
- Temperatures from -75°C (-100°F) to 370°C (700°F)

Features

- Exclusive reverse vane impeller
- Standard Mark 3A power end
 - External micrometer impeller adjustment
 - Double row angular contact outboard bearings and single row, deep groove inboard bearings
 - Double lip oil seals
 - Constant level oiler
 - Large, reflective sight glass
- Choice of lubrication systems
- Optional ANSI 3A power end with lifetime warranty
 - Certified clean room assembly
 - Inpro/Seal® VBXX isolators
 - Magnetic drain plug
- SealSentry™ seal chambers
- Largest shaft and bearing components in ANSI standard pumps
- Optional inducer

Related Configurations

- Mark 3 Lo-Flo
- Mark 3 Unitized Self-Primer
- Mark 3 Recessed Impeller
- Mark 3 Sealmatic dynamically sealed

See Bulletin PS-10-13

Mark 3 Lo-Flo

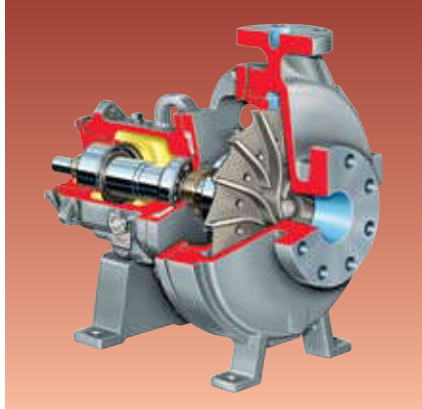

Standards

- ASME (ANSI) B73.1

Operating Parameters

- Flows to 50 m³/h (220 gpm)
- Heads to 300 m (1000 ft)
- Pressures to 30 bar (450 psi)
- Temperatures from -75°C (-100°F) to 370°C (700°F)

Features

- Circular, concentric casing
- Radial vane impeller
- Standard Mark 3A power end
 - External micrometer impeller adjustment
 - Double row angular contact outboard bearings and single row, deep groove inboard bearings
 - Double lip oil seals
 - Constant level oiler
 - Large, reflective sight glass
- Choice of lubrication systems
- Optional ANSI 3A power end with lifetime warranty
 - Certified clean room assembly
 - Inpro/Seal VBXX isolators
 - Magnetic drain plug
- SealSentry seal chambers
- Oversized shaft and bearing components

See Bulletin PS-10-13

© Inpro/Seal is a registered trademark of Inpro/Seal Company.

Mark 3 Unitized Self-Primer

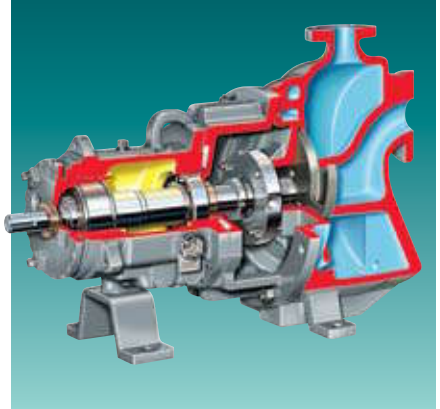

Standards

- Flowserve

Operating Parameters

- Flows to 320 m³/h (1400 gpm)
- Heads to 120 m (400 ft)
- Pressures to 20 bar (285 psi)
- Temperatures to 370°C (700°F)
- Static suction lift to 6 m (20 ft)

Features

- Unitized casing with large priming chamber, air separator and volute
- Exclusive reverse vane impeller standard; open impeller optional
- Standard Mark 3A power end
 - External micrometer impeller adjustment
 - Double row angular contact outboard bearings and single row, deep groove inboard bearings
 - Double lip oil seals
 - Constant level oiler
 - Large, reflective sight glass
- Choice of lubrication systems
- Optional ANSI 3A power end with lifetime warranty
 - Certified clean room assembly
 - Inpro/Seal VBXX isolators
 - Magnetic drain plug
- SealSentry seal chambers
- Oversized shaft and bearing components

See Bulletin PS-10-13

Mark 3 Recessed Impeller



Standards

- Flowserve

Operating Parameters

- Flows to 455 m³/h (2000 gpm)
- Heads to 120 m (400 ft)
- Pressures to 20 bar (285 psi)
- Temperatures from -75°C (-100°F) to 370°C (700°F)

Features

- Low shear vortex pumping action
- Fractional media contact with the impeller
- Standard CD4MCuN impeller
- Thick-wall wet end components suitable for light slurries
- Standard Mark 3A power end
 - External micrometer impeller adjustment
 - Double row angular contact out-board bearings and single row, deep groove inboard bearings
 - Double lip oil seals
 - Constant level oiler
 - Large, reflective sight glass
- Optional ANSI 3A power end with lifetime warranty
 - Certified clean room assembly
 - Inpro/Seal VBXX isolators
 - Magnetic drain plug
- SealSentry seal chambers
- Oversized shaft and bearing

Related Configurations

- Mark 3 ASME standard
- Mark 3 Sealmatic, recessed impeller

See Bulletin PS-10-13

Mark 3 In-Line

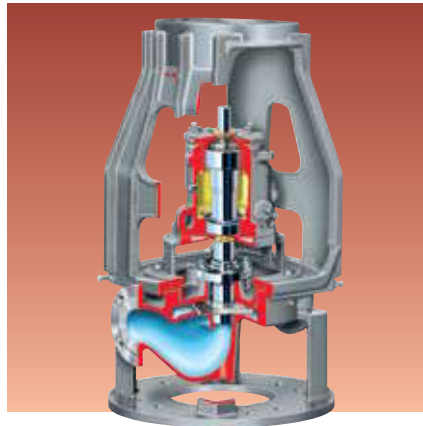

Standards

- ASME (ANSI) B73.2

Operating Parameters

- Flows to 370 m³/h (1630 gpm)
- Heads to 230 m (760 ft)
- Pressures to 24 bar (350 psi)
- Temperatures from -75°C (-100°F) to 370°C (700°F)

Features

- Exclusive reverse vane impeller
- Standard Mark 3A power end
 - External micrometer impeller adjustment
 - Double row angular contact out-board bearings and single row, deep groove inboard bearings
 - Double lip oil seals
- Optional ANSI 3A power end with lifetime warranty
 - Certified clean room assembly
 - Inpro/Seal VBXX isolators
- SealSentry seal chambers
- Unique C-plus motor and pump shaft alignment system
- Choice of bearing lubrication
 - Regreasable bearings
 - Oil mist
 - Permanently lubricated bearings

Related Configurations

- Mark 3 in-line, recessed impeller

See Bulletin PS-10-15

Guardian Magnetic Drive

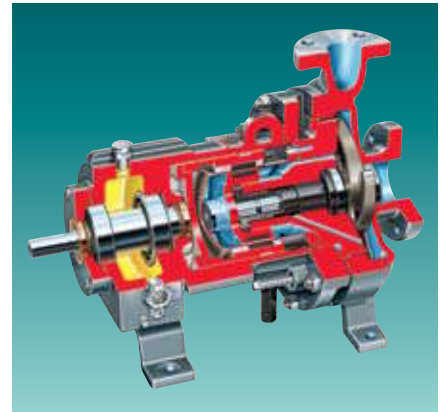

Standards

- ASME (ANSI) B73.1 dimensions

Operating Parameters

- Flows to 375 m³/h (1650 gpm)
- Heads to 215 m (700 ft)
- Pressures to 24 bar (350 psi)
- Temperatures from -75°C (-100°F) to 290°C (550°F)

Features

- Magnetic drive design
- Alloy C-276 containment shell
- Rare earth magnets
- Low NPSHR, reverse vane impeller
- Casings and impellers interchangeable with sealed configuration
- Optimized internal lubrication path
- Silicon carbide bushings and journals with double spiral grooves
- Standard and contained back pullout
- Options
 - Fiber-optic leak detection
 - Containment shell temperature probes
 - Process temperature probes
 - External flush plans

Available Configurations

- G-Series: -75°C (-100°F) to 120°C (250°F)
- H-Series: -120°C (-250°F) to 290°C (550°F)

See Bulletin P-10-14

CPX3 ISO Standard

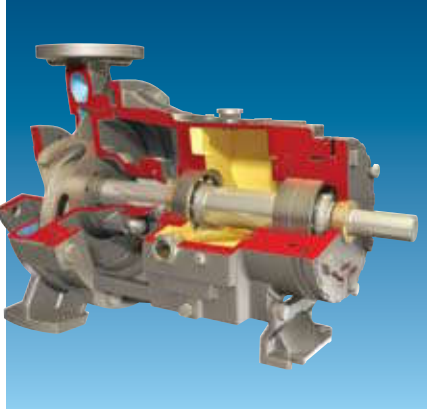

Standards

- ISO 2858
- ISO 5199

Operating Parameters

- Flows to 1400 m³/h (6160 gpm)
- Heads to 220 m (720 ft)
- Pressures to 25 bar (365 psi)
- Temperatures from -80°C (-110°F) to 350°C (660°F)
- 40 sizes with discharges from 20 mm (0.75 in) to 200 mm (8 in)

Features

- Heavy-duty casing with integral foot and multi-ribbed discharge flange
- Reverse vane impeller standard; open impeller available
- SealSentry seal chambers
- Accepts multiple seal arrangements
- External micrometer impeller adjustment mechanism
- Standard non-contacting labyrinth seal
- Heavy-duty radial and thrust bearings
- One-piece, ductile iron bearing housing
- Back pullout design
- CE marked and compliant with applicable European directives such as ATEX; available with GOST cert.

Related Configurations

- CPX3 Self-Priming
- CPX3 Recessed Impeller
- CPX3 Close Coupled
- CPXV Chemical Sump
- CPX3 centerline mounted

See Bulletin PS-10-30

CPX3 Self-Priming



Standards

- ISO 2858
- ISO 5199

Operating Parameters

- Flows to 100 m³/h (440 gpm)
- Heads to 100 m (330 ft)
- Pressures to 25 bar (365 psi)
- Temperatures from -80°C (-110°F) to 350°C (660°F)

Features

- One-piece casing with integral priming chamber, air separator and volute
- Reflux priming principle eliminates need for internal valves and external priming devices
- High-efficiency, low NPHSr, precision cast, semi-open impeller
- Run dry capability
- SealSentry seal chambers
- Accepts multiple seal arrangements
- External micrometer impeller adjustment mechanism
- Standard non-contacting labyrinth seal
- Heavy-duty radial and thrust bearings
- Back pullout design
- CE marked and compliant with applicable European directives such as ATEX; available with GOST cert.

Other Configurations

- CPX3 close coupled, self-priming
- CPX3 magnetically driven, self-priming
- CPX3 close coupled, magnetically driven, self-priming

See Bulletin PS-10-30

CPX3 Recessed Impeller

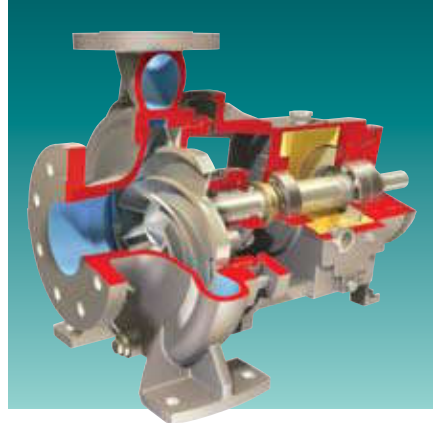

Standards

- ISO 2858
- ISO 5199

Operating Parameters

- Flows to 750 m³/h (3300 gpm)
- Heads to 100 m (330 ft)
- Pressures to 25 bar (365 psi)
- Temperatures from -80°C (-110°F) to 350°C (660°F)

Features

- Heavy-duty casing with integral foot and multi-ribbed discharge flange
- Vortex action minimizes abrasive wear and maintains solids integrity
- Standard high-efficiency, semi-open impeller precision cast in CD4MCuN duplex stainless steel
- SealSentry seal chambers
- Accepts multiple seal arrangements
- External micrometer impeller adjustment mechanism
- Standard non-contacting labyrinth seal
- Heavy-duty radial and thrust bearings
- One-piece, ductile iron bearing housing
- Back pullout design
- CE marked and compliant with applicable European directives such as ATEX; available with GOST cert.

Other Configurations

- CPX3 recessed impeller, vertical sump
- CPX3 close coupled, recessed impeller

See Bulletin PS-10-30

CPX3 Close Coupled

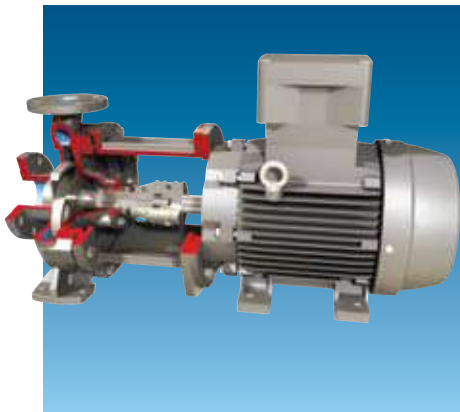

Standards

- ISO 2858
- ISO 5199

Operating Parameters

- Flows to 750 m³/h (3300 gpm)
- Heads to 100 m (330 ft)
- Pressures to 25 bar (365 psi)
- Temperatures from -80°C (-110°F) to 350°C (660°F)

Features

- Compact, space-saving configuration
- Investment cast muff coupling
- Heavy-duty casing with integral foot and multi-ribbed discharge flange
- Radiating surfaces
- Reverse vane impeller standard; open impeller available
- SealSentry seal chambers
- Accepts multiple seal arrangements
- External micrometer impeller adjustment mechanism
- Accepts standard electric motors
- Standard non-contacting labyrinth seal
- Back pullout design
- CE marked and compliant with applicable European directives such as ATEX; available with GOST cert.

Other Configurations

- CPX3 close coupled, recessed impeller
- CPX3 close coupled, self-priming
- CPX3 close coupled, magnetic drive

See Bulletin PS-10-30

CPXV Chemical Sump



Standards

- ISO 13709/API 610, 8th & 10th ed.
- ISO 5199

Operating Parameters

- Flows to 1400 m³/h (6160 gpm)
- Heads to 250 m (820 ft)
- Pressures to 25 bar (365 psi)
- Temperatures from -40°C (-40°F) to 350°C (660°F)

Features

- Heavy-duty casing with multi-ribbed discharge flange
- High-efficiency, semi-open impeller
- Column lengths to 10 m (32 ft)
- Heavy-duty thrust bearings with axial adjustment above soleplate level
- Accepts multiple seal arrangements
- Elastomeric split element coupling
- Options
 - Recessed impeller
 - Suction strainer
 - Spacer coupling
 - Rectangular or circular soleplate
 - Oil lubrication to thrust bearing
 - Zone Ø hazardous area beneath soleplate configuration
- CE marked and compliant with applicable European directives such as ATEX; available with GOST cert.

Other Configurations

- CPX3 recessed impeller, chemical sump
- Fully jacketed, molten salt design

See Bulletin PS-10-30

CPXS Magnetic Drive

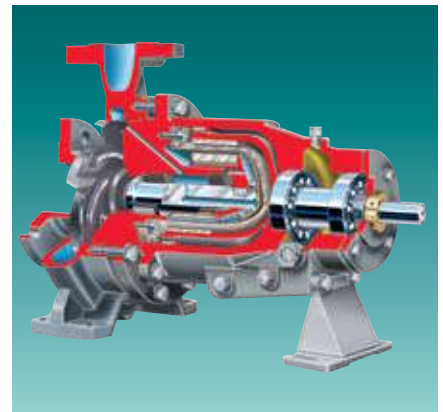

Standards

- ISO 2858
- ISO 15783

Operating Parameters

- Flows to 420 m³/h (1850 gpm)
- Heads to 160 m (525 ft)
- Pressures to 25 bar (365 psi)
- Temperatures from -40°C (-40°F) to 250°C (480°F)

Features

- Reinforced PEEK® or Alloy C-276 primary containment shell
- Optional Alloy C-276 secondary containment shell
- High-performance rare earth magnets
- Large inner magnet clearances
- Optimized internal flow circulation path
- Heavy-duty casing with integral foot and multi-ribbed discharge flange
- High-efficiency, low NPHSr, precision cast, semi-open impeller
- Advanced sintered silicon carbide bushings and journal bearings
- Standard and contained back pullout design
- CE marked and compliant with applicable European directives such as ATEX; available with GOST cert.

Other Configurations

- CPX3 close coupled, magnetic drive
- CPX3 magnetically driven, self-priming

See Bulletin PS-10-30

© PEEK is a registered trademark of Victrex plc Corp.

PolyChem GRP Engineered Polymer Composite

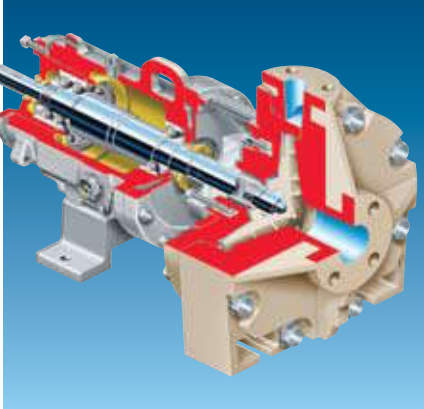

Standards

- ASME (ANSI) B73.5

Operating Parameters

- Flows to 2050 m³/h (9000 gpm)
- Heads to 150 m (500 ft)
- Pressures to 17 bar (250 psi)
- Temperatures from -45°C (-50°F) to 120°C (250°F)

Features

- Glass reinforced vinyl ester
- Unitized casing with integrally molded, fully gusseted suction and discharge flanges
- Tapered polygon impeller drive
- Seal chamber accommodates multiple seals, glands and flush arrangements
- Standard Mark 3A power end
 - External micrometer impeller adjustment mechanism
 - Double row angular contact out-board bearings and single row, deep groove inboard bearings
 - Double lip oil seals
 - Constant level oiler
- Optional ANSI 3A power end with lifetime warranty
 - Certified clean room assembly
 - Inpro/Seal VBXX isolators
 - Magnetic drain plug

Related Configurations

- PolyChem VGRP engineered polymer composite sump
- Self-primer

See Bulletin PS-10-17

PolyChem VGRP Engineered Polymer Composite Sump

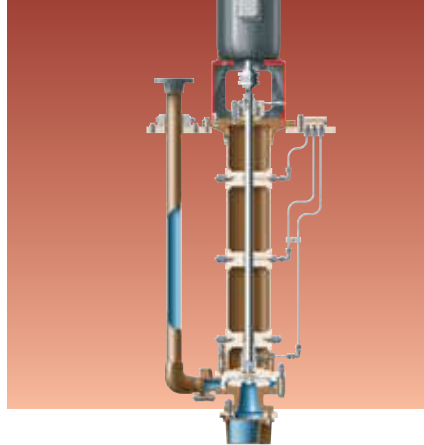

Standards

- Flowserve

Operating Parameters

- Flows to 565 m³/h (2500 gpm)
- Heads to 110 m (350 ft)
- Pressures to 17 bar (250 psi)
- Temperatures from -30°C (-20°F) to 90°C (200°F)

Features

- Glass reinforced vinyl ester
- Unitized casing with integrally molded, fully gusseted suction and discharge flanges
- Externally adjustable, semi-open impeller
- Shaft and bearing system operates well below the first critical speed
- Self-lubricated or external flush bearings
- Single-piece, lightweight, filament-wound, reinforced fiberglass composite column
- Single and duplex configurations
- Full basket strainer
- NEMA in-line motor
- Fiberglass mounting plate
- Tapered polygon impeller drive
- Pullout bearing retainers
- Level controls
- Choice of shaft metallurgy

Related Configurations

- PolyChem GRP engineered polymer composite

See Bulletin PS-10-17

PolyChem S-Series Fluoropolymer Lined

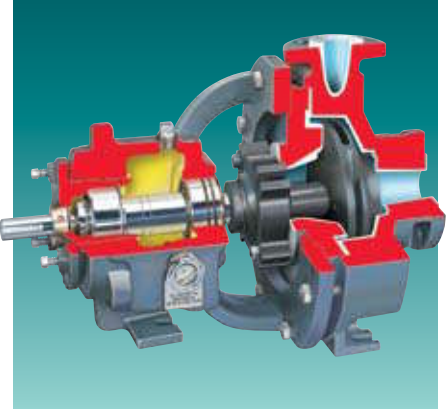

Standards

- ASME (ANSI) B73.1
- ISO 2858
- JIS drilling

Operating Parameters

- Flows to 420 m³/h (1850 gpm)
- Heads to 145 m (480 ft)
- Pressures to 17 bar (250 psi)
- Temperatures from -30°C (-20°F) to 150°C (300°F)

Features

- PFA lined wet end
- Metal armor meets material specifications of ASTM A395 and GGG 40.3
- Enclosed impeller standard; open impeller optional
- Standard Mark 3A power end
- SealSentry seal chamber accommodates multiple seal types
- Shaft options
 - Standard silicon carbide shaft sleeve
 - Alloy shaft sleeves
 - Solid shafts
- Bearing housing options
 - Labyrinth oil seals
 - Oil slinger
 - Regreasable or double shielded bearings
 - Oil mist lubrication
- Optional ANSI 3A power end with lifetime warranty
 - Certified clean room assembly
 - Inpro/Seal VBXX isolators
 - Magnetic drain plug

See Bulletin PS-10-17

PolyChem M-Series Fluoropolymer Lined, Magnetic Drive

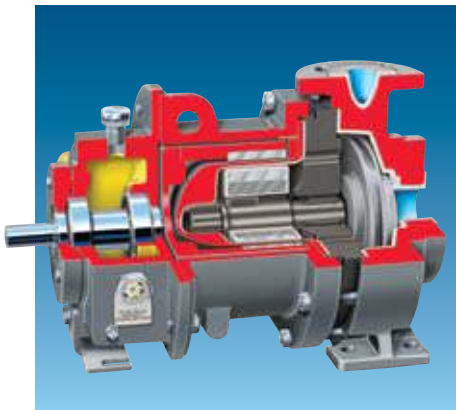

Standards

- ASME (ANSI) B73.1
- ISO 2858
- JIS drilling

Operating Parameters

- Flows to 135 m³/h (600 gpm)
- Heads to 145 m (480 ft)
- Pressures to 17 bar (250 psi)
- Temperatures from -30°C (-20°F) to 150°C (300°F)

Features

- PFA-lined wet end
- Casing is ductile cast iron with 3 mm (0.1 in) minimum PFA liner thickness
- PFA-lined fiberglass containment shell
- Enclosed PFA-lined impeller
- Rare earth magnets in synchronous drive
- Metal armor meets material specifications of ASTM A395 and GGG40.3
- Separate inner magnet and impeller components
- Rotating shaft design
- Silicon carbide radial and axial thrust bearings
- Choice of bearing lubrication
- Options
 - Long and close coupled designs
 - ANSI 3A power end

See Bulletin PS-10-17

Polyshield Baseplate and Foundation System

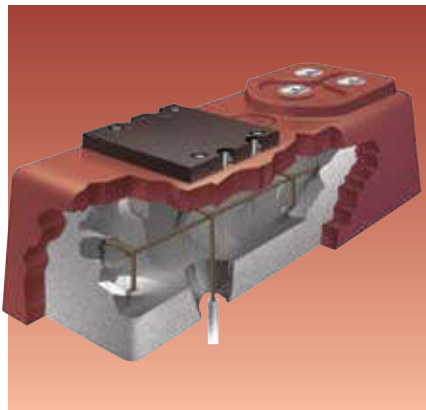

Standards

- Flowserve

Operating Parameters

- Temperatures to 260°C (500°F)

Features

- Combines non-metallic baseplate and formed concrete foundation for pump-driver in one complete unit
- Excellent corrosion resistance
- Improved vibration dampening
- Reduced installation costs and time
- Solid one-piece polymer motor mounting block with four 304 SS transverse motor block adjusters
- Self-venting design with grout hole and plug
- Standard 316 stainless steel inserts
- Integral catch basin with NPT connection
- Uses 200 bar (3000 psi) concrete
- Suitable with ANSI, ISO, API and other foot-mounted and centerline mounted pumps
- Outstanding flatness
- Options
 - Choice of three polymer materials
 - Alloy 20 and Alloy C-276 inserts available
 - CPVC drain connection

See Bulletin PS-90-2

Polybase Polymer Concrete Baseplate

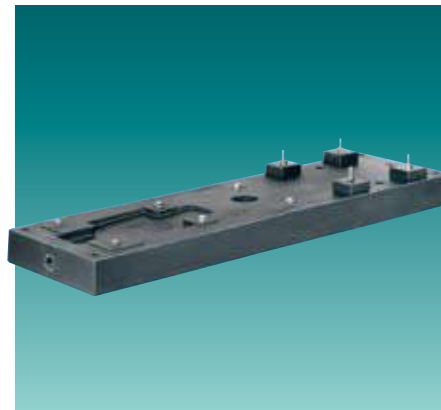

Standards

- ANSI and ISO standard designs

Features

- Solid polymer concrete construction
- Low installed cost
- Superior flatness
- Enhanced vibration dampening
- Excellent corrosion resistance
- Outstanding resistance to twisting or diaphragming
- 8-point™ adjuster alignment system
- Choice of three polymer materials
- Options
 - Polybloc™ motor mounting blocks
 - Catch basin
 - Grout hole
 - Alternate equipment inserts

See Bulletin PS-10-13

HPX (OH2) Centerline Mounted

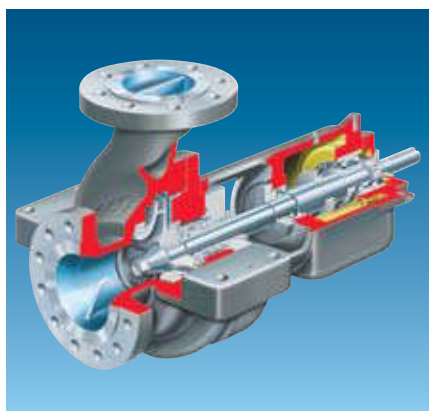

Standards

- ISO 13709/API 610 (OH2), latest ed.

Operating Parameters

- Flows to 2000 m³/h (8800 gpm)
- Heads to 350 m (1100 ft)
- Pressures to 80 bar (1160 psi)
- Temperatures from -160°C (-250°F) to 450°C (840°F)

Features

- Centerline supported casing
- Nozzle loading capability beyond ISO 13709/API 610 requirements
- Dynamically balanced impeller
- Rugged shaft design
- ISO 21049/API 682 seal chamber accommodates multiple seal types
- Choice of bearings
 - Standard single row, deep groove, radial bearing and duplex, single row 40° angular contact thrust bearings
 - Special bearing arrangements for high suction pressures
- Bearing lubrication and cooling options
 - Oil mist and oil purge
 - Fan cooling
 - Finned cooling insert

Related Configurations

- HPXT centerline mounted, top suction
- HPXH centerline mounted, high suction pressure
- HPXSL centerline mounted, slurry
- HPXIND centerline mounted, inducer
- HPXCC centerline mounted, coke crusher

See Bulletin PS-10-5

HPXM (OH2) Centerline Mounted, Low Flow

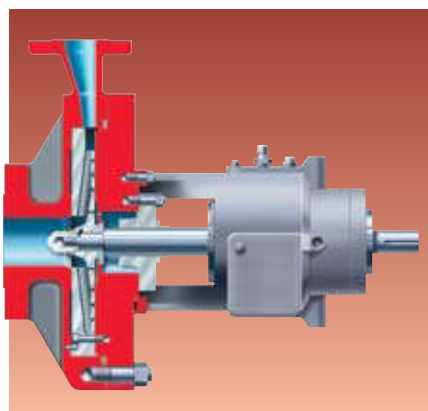

Standards

- ISO 13709/API 610 (OH2), latest ed.

Operating Parameters

- Flows to 30 m³/h (130 gpm)
- Heads to 280 m (920 ft)
- Pressures to 80 bar (1160 psi)
- Temperatures from -160°C (-250°F) to 450°C (840°F)

Features

- Low flow, high head design
- Replaceable volute inserts
- High-efficiency patented design radial blade impeller
- Full interchangeability with HPX bearing assembly and mechanical seals
- Choice of bearings
 - Standard single row, deep groove, radial bearing and duplex, single row 40° angular contact thrust bearings
 - Special bearing arrangements for high suction pressures
- ISO 21049/API 682 seal chamber accommodates multiple seal types
- Bearing lubrication and cooling options
 - Oil mist and oil purge
 - Fan cooling
 - Finned cooling insert
- Optional inducer

Related Configurations

- HPX centerline mounted

See Bulletin PSS-10-5.1

PHL (OH2) Centerline Mounted

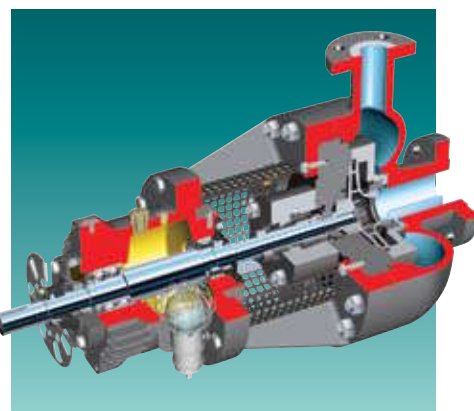

Standards

- ISO 13709/API 610 (OH2), latest ed.

Operating Parameters

- Flows to 900 m³/h (4000 gpm)
- Heads to 400 m (1300 ft)
- Pressures to 40 bar (600 psi)
- Temperatures from -160°C (-250°F) to 450°C (840°F)
- Motor sizes to 110 kW (150 hp)

Features

- Centerline supported, end suction casing
- Custom-tuned hydraulics
- Multi-channel diffuser technology
 - Customized BEP fits
 - High efficiency
 - Extended MTBR
 - Low vibration
 - Low noise
- Low shaft deflection at any flow
- ISO 21049/API 682 seal chamber accommodates multiple seal types including dual pressurized, unpressurized and gas
- Bearing housing cooling options
 - Air fan
 - Water jacket
- Replaceable diffusers
- Available boron diffusion surface treatment

Other Configurations

- Top suction nozzle

See Bulletin PSS-10-5.2

ERP Centerline Mounted

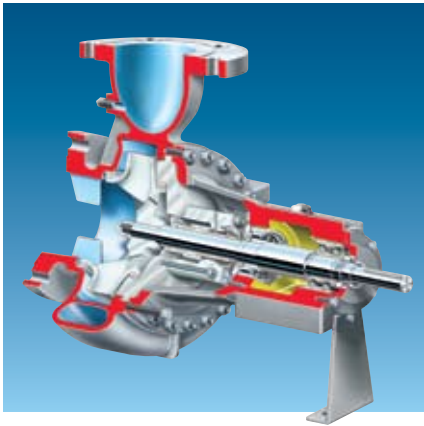

Standards

- Flowserve

Operating Parameters

- Flows to 1100 m³/h (4800 gpm)
- Heads to 230 m (750 ft)
- Pressures to 60 bar (870 psi)
- Temperatures to 350°C (660°F)

Features

- Critical parameters meet ISO 13709/API 610 (OH2)
 - Vibration limits
 - Deflection limits at seal faces
 - Nozzle loading capabilities
 - Balancing grades
- ISO 21049/API 682 seal chamber accommodates multiple seal types
- Dynamically balanced, high-efficiency impeller
- Centerline supported casing
- Double volute design for discharge flanges 80 mm (3 in) and larger
- Renewable casing and cover wear rings
- Back pullout design
- Optional inducer
- Choice of API materials

Related Configurations

- ERPN-O semi-open impeller
- High suction pressure: 35 bar (500 psi)

See Bulletin PS-10-20

PVXM (OH3) Vertical In-Line

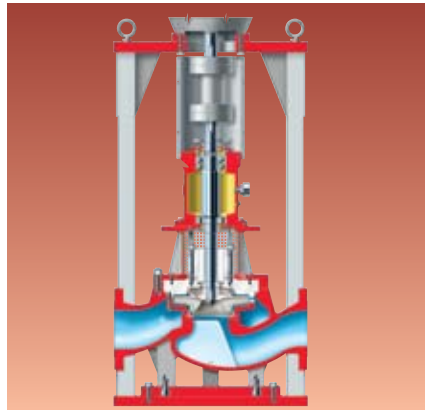

Standards

- ISO 13709/API 610 (OH3), latest ed.

Operating Parameters

- Flows to 500 m³/h (2200 gpm)
- Heads to 275 m (900 ft)
- Pressures to 40 bar (600 psi)
- Temperatures from -100°C (-148°F) to 250°C (480°F)

Features

- Space saving design
- Precision machined diffusers
- Customizable hydraulics – 150 BEP hydraulic fits with 10 casings
- Casing and cover design with metal-to-metal fits and fully confined compression gasket
- ASME (ANSI) B16.5 Class 300 raised face flanges
- Dynamically balanced impeller
- Optimized NPSHr due to suction box design
- ISO 21049/API 682 seal chamber
- Heavy-duty motor support head fits NEMA, C-Face and IEC drivers
- 100% back pullout design
- Flexible disc spacer coupling
- Upper and lower labyrinth bearing isolators; optional radial lip seals
- Bearing lubrication options
 - Oil cascade
 - Oil mist
 - Grease lube

Related Configurations

- PVML vertical in-line

See Bulletin PS-10-29

HWMA (OH3) Vertical In-line, Low-Flow High-Head

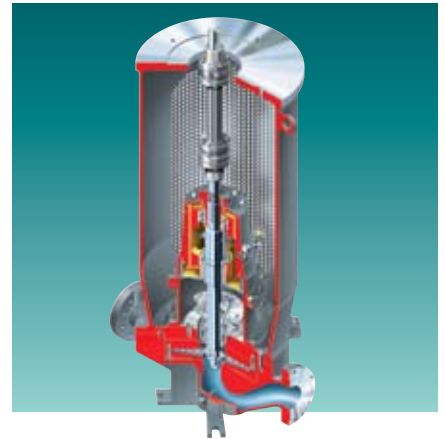

Standards

- ISO 13709/API 610 (OH3), latest ed.

Operating Parameters

- Flows to 45 m³/h (200 gpm)
- Heads to 440 m (1455 ft)
- Pressures to 60 bar (870 psi)
- Temperatures from -50°C (-58°F) to 260°C (500°F)

Features

- Space saving design
- Low-flow, high-head hydraulics
- Replaceable volute inserts
- Customizable hydraulics – 80 BEP fits in a single pump size
- Casing and cover design with metal-to-metal fits and fully confined compression gasket
- ASME (ANSI) B16.5 Class 600 raised face flanges; flat face optional
- Patented radial blade impeller
- Optional inducer for low NPSHr
- ISO 21049/API 682 seal chamber
- Heavy-duty motor support head fits NEMA, C-Face, P-base and IEC drivers
- 100% back pullout design
- Flexible disc spacer coupling
- Upper labyrinth bearing isolator; optional radial lip seals
- Choice of bearing lubrication systems

Related Configurations

- WMA rigidly coupled, vertical in-line
- HWMA2 two stage, vertical in-line
- WMA2 rigidly coupled, two stage, vertical in-line

See Bulletin PS-10-25

PVML (OH5)
Vertical In-Line

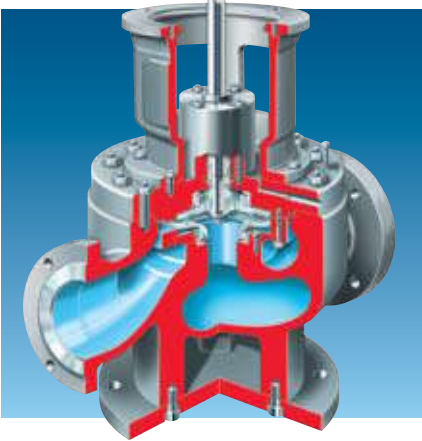

Standards

- ISO 13709/API 610 (OH5), latest ed.
- BS 4082R

Operating Parameters

- Flows to 500 m³/h (2200 gpm)
- Heads to 275 m (900 ft)
- Pressures to 40 bar (580 psi)
- Temperatures from -100°C (-148°F) to 250°C (480°F)

Features

- Space-saving, alignment-free design
- Custom-tuned hydraulics
- State-of-the-art diffuser technology
 - Customized BEP fits
 - High efficiency
 - Extended MTBR
 - Low vibration
 - Low noise
- ISO 21049/API 682 seal chamber accommodates multiple seal types
- Dynamically balanced impeller
- Positively locked, anti-rotation impeller nut with threads unexposed to pumped fluid

Related Configurations

- PVXM vertical in-line

See Bulletin PS-10-28

MSP
Vertical In-Line,
Medium Speed



Standards

- Flowserve

Operating Parameters

- Flows to 27 m³/h (120 gpm)
- Heads to 900 m (2955 ft)
- Pressures to 60 bar (870 psi)
- Maximum suction pressure to 40 bar (580 psi)
- Temperatures from -40°C (-40°F) to 350°C (660°F)
- Speeds from 2000 rpm to 8000 rpm

Features

- Closely follows ISO 13709/API 610 (OH4), latest edition
- Modified concentric volute
- Open impeller with balance holes and scallops
- Variable frequency drive
- Rigid coupling
- Single or dual cartridge mechanical seals
- Options
 - Inducer
 - Choice of materials

Available Configurations

- Horizontal configuration
- MSP vertical in-line, single stage
- MSP2 vertical in-line, two stage (opposed impellers)

See Bulletin PS-10-1

DSVP (OH4)
Vertical In-Line

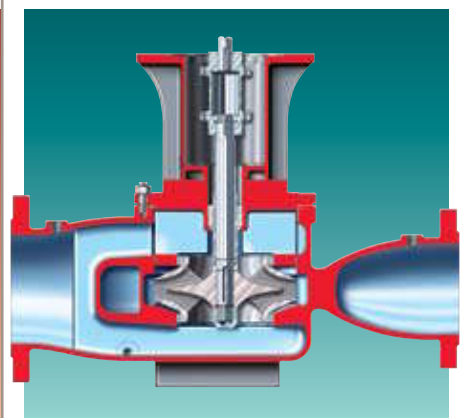

Standards

- ISO 13709/API 610 (OH4), latest ed.

Operating Parameters

- Flows to 3400 m³/h (15 000 gpm)
- Heads to 85 m (275 ft)
- Pressures to 40 bar (600 psi)
- Temperatures to 340°C (650°F)
- Motor ratings to 895 kW (1200 hp)

Features

- Space-saving design
- ISO 21049/API 682 seal chamber accommodates multiple seal types
- Double suction enclosed impeller
- Double volute case design
- Standard case wear rings
- Optional impeller wear rings
- Metal-to-metal case to cover sealing with confined gasket
- Rigid spacer type coupling
- Impeller nut design, threaded to tighten with rotation

M
**Hard Metal,
 Abrasive Slurry**

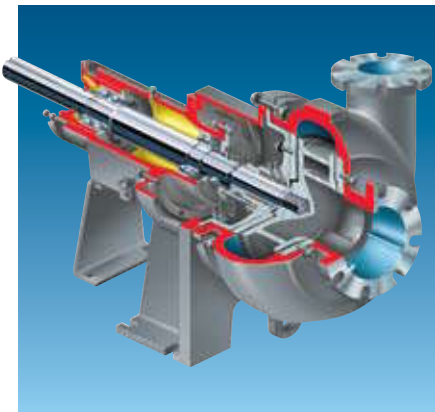

Standards
 • Flowserve

Operating Parameters

- Flows to 10 000 m³/h (44 000 gpm)
- Heads to 90 m (300 ft)
- Pressures to 10 bar (150 psi); 50 bar (725 psi) with the high pressure model
- Temperatures to 120°C (250°F)
- Solids from 2% to 70% by weight

Features

- One-piece high chrome iron, concentric casing with replaceable gland and suction side wear plates
- Closed impeller with pump-out vanes on front and rear shrouds
- Standard packing-type stuffing box with replaceable wear plate
- Full and low flow flush connections
- Heavy-duty bearing frame designed for V-belt loads
- Cartridge style bearings
- Parts interchangeable with R pump
- Three-point external end clearance adjustment
- Options
 - Vortex semi-recessed impeller
 - Hard metal expeller
 - Mechanical seal housing

Related Configurations

- Severe-duty model
- High-pressure model
- MJ slurry sump
- MJC cantilever slurry sump

See Bulletin PS-10-19

R
**Radially Split,
 Rubber Lined Slurry**

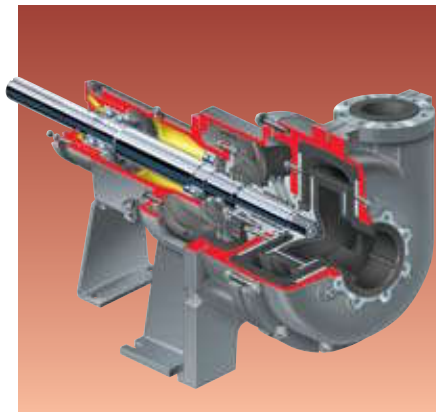

Standards
 • Flowserve

Operating Parameters

- Flows to 10 000 m³/h (44 000 gpm)
- Heads to 50 m (165 ft)
- Pressures to 10 bar (150 psi) standard; 35 bar (510 psi) optional
- Temperatures to 110°C (225°F)
- Solids from 2% to 70% by weight

Features

- Concentric, cast iron casing with replaceable, abrasion-resistant rubber liner
- Rubber lined, closed impeller with front and rear pump-out vanes
- Standard packing type stuffing box with replaceable wear plate
- Full and low flow flush connections
- Heavy-duty bearing frame
- Three-point, external end clearance adjustment
- Parts interchangeable with M pump
- Directly coupled or V-belt driven
- Options
 - Acid-resistant stuffing box kits
 - Hard metal expeller
 - Mechanical seal housing
 - Choice of liner materials

Related Configurations

- RJ rubber lined, slurry sump
- RJC cantilever rubber lined, slurry sump

See Bulletin PS-10-18

Titan Slurry
**Heavy-Duty,
 Radially Split, Lined**

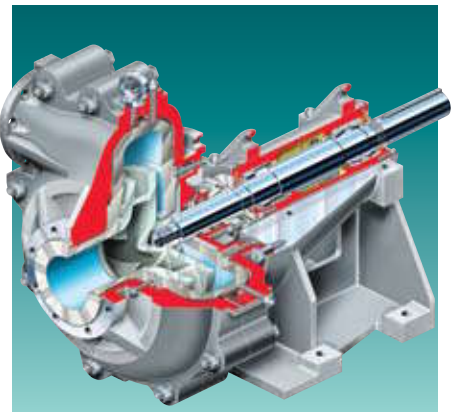

Standards
 • Flowserve

Operating Parameters

- Flows to 3600 m³/h (16 000 gpm)
- Heads to 90 m (300 ft)
- Pressures to 40 bar (580 psi)
- Sizes from 50 mm (2 in) to 350 mm (14 in)

Features

- Fully interchangeable elastomeric or hard metal liners
- Radially split casing
- High-efficiency, closed impeller
- Ample seal chamber accommodates a variety of packing and seal types
- Heavy-duty bearing frame sized to handle belt loads
- Bearing cartridge with back-to-back angular contact thrust bearings
- Roller type radial bearings
- Contact lip seals
- Dimensionally compatible with the industry's most widely used pumps
- Optional expeller for dynamic sealing

Available Configurations

- Metal lined model
- Rubber lined model
- High-pressure model

See Bulletin PS-10-8

LC
Chemical Slurry

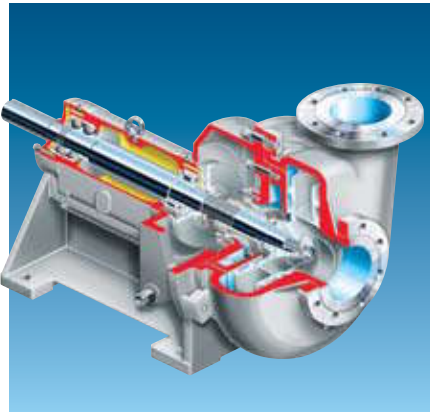

- Standards**
- Flowsolve

- Operating Parameters**
- Flows to 8000 m³/h (35 200 gpm)
 - Heads to 90 m (300 ft)
 - Pressures to 25 bar (360 psi)
 - Temperatures to 140°C (285°F)
 - Specific gravities to 1.7

- Features**
- Concentric casing with tangential discharge
 - Rigid, one-piece bearing frame with two angular contact outboard bearings and roller inboard bearings
 - Large diameter, heavy-duty shaft
 - Choice of shaft sealing options
 - Wet gland packing
 - Single or double mechanical seal
 - High-pressure double mechanical seal
 - Special high solids seals
 - Alumina industry seal
 - Choice of materials of construction
 - Multiple impeller designs
 - Direct coupled or belt driven
 - Choice of six drive arrangements
 - Options
 - Inducer
 - Stuffing box cooling system

- Related Configurations**
- PL-C cantilever, chemical slurry sump
 - LC-S lineshaft, chemical slurry sump

See Bulletin PS-10-11

MND
Hard Metal
Absorber Recirculation

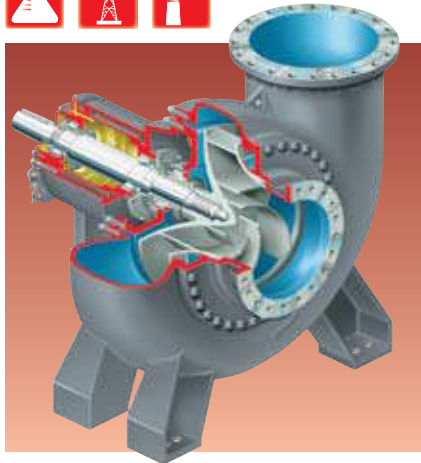

- Standards**
- Flowsolve

- Operating Parameters**
- Flows to 17 500 m³/h (77 000 gpm)
 - Heads to 40 m (130 ft)
 - Sizes from 600 mm (24 in) to 1000 mm (40 in)

- Features**
- One-piece, high-efficiency impeller with mixed flow vane design
 - Multiple materials of construction
 - Replaceable casing wear ring
 - Opposed tapered roller bearings designed for a minimum B10 life of 100 000 hours
 - Product flush slurry seal
 - External end clearance adjustment
 - Front and back pullout

- Related Configurations**
- Vertical mounting
 - MNR rubber lined absorber recirculation

See Bulletin PS-10-32

MNR
Rubber Lined
Absorber Recirculation

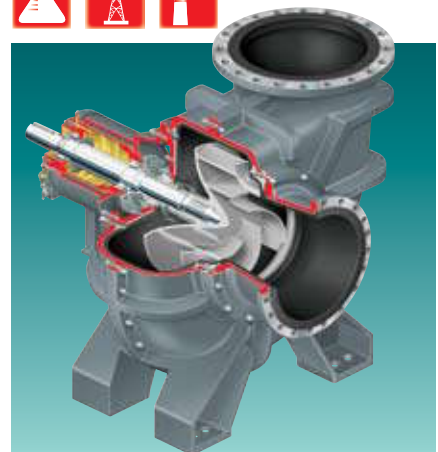

- Standards**
- Flowsolve

- Operating Parameters**
- Flows to 17 500 m³/h (77 000 gpm)
 - Heads to 40 m (130 ft)
 - Sizes from 600 mm (24 in) to 1000 mm (40 in)

- Features**
- One-piece, high-efficiency impeller with mixed flow vane design
 - Removable one-piece elastomeric casing liner
 - Radially split casing
 - Multiple materials of construction
 - Replaceable casing wear ring
 - Opposed tapered roller bearings designed for a minimum B10 life of 100 000 hours
 - Product flush slurry seal
 - External end clearance adjustment
 - Front and back pullout

- Related Configurations**
- Vertical mounting
 - MND hard metal absorber recirculation

See Bulletin PS-10-32

FRBH
Heavy-Duty Paper Stock
and Process

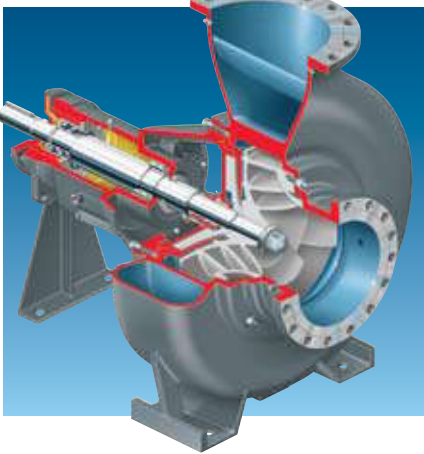

Standards

- Flowserve

Operating Parameters

- Flows to 9085 m³/h (40 000 gpm)
- Heads to 100 m (330 ft)
- Pressures to 14 bar (200 psi)
- Temperatures to 150°C (300°F)

Features

- Self-venting, top centerline discharge casing
- Semi-open, full vane impeller with back pump-out vanes
- Large suction inlet
- Seal chamber accepts packing or mechanical seal
- Three-point end clearance adjustment
- Back pullout design
- Heavy-duty, oil-lubricated bearings
- Fully split interlocking glands
- Extra heavy-duty alloy steel shaft
- Contoured wearplate match machined with impeller
- Dry shaft construction with sealed impeller nut and stainless steel hook sleeve
- Rigid, one-piece bearing frame
- Options
 - Large conical seal housing
 - Inducer
 - Expeller
 - Recessed impeller

Related Configurations

- FRBHJC cantilever sump
- FRBHJ sump

See Bulletin PS-10-16

FRBHJC
Cantilever Sump

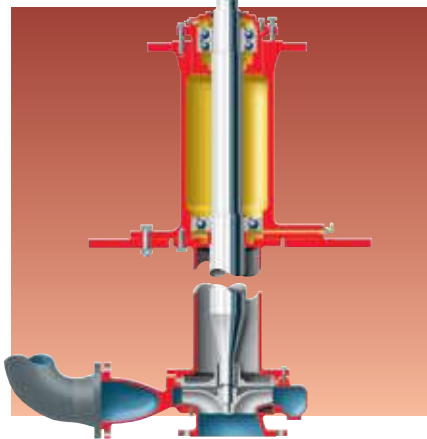

Standards

- Flowserve

Operating Parameters

- Flows to 2700 m³/h (12 000 gpm)
- Heads to 100 m (330 ft)
- Temperatures to 150°C (300°F)
- Speeds to 1780 rpm

Features

- True stiff shaft cantilever design, without bottom bearing or flushing water
- Steep head-capacity
- Semi-open, full vane impeller with back pump-out vanes
- Direct coupled or V-belt driven
- Extra heavy-duty alloy steel shaft

Related Configurations

- FRBH heavy-duty paper stock and process
- FRBHJ vertical lineshaft sump

See Bulletin PS-10-16

MPT
Self-Priming,
Solids Handling

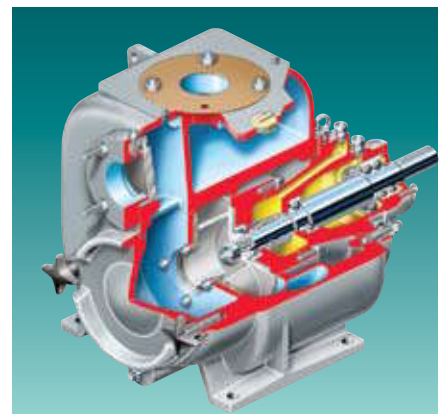

Standards

- Flowserve

Operating Parameters

- Flows to 600 m³/h (2650 gpm)
- Heads to 35 m (115 ft)
- Temperatures to 75°C (165°F)
- Working pressures to 5 bar (72 psi)
- Sizes 50 to 200 mm (2 to 8 in)
- Solids to 75 mm (3 in) diameter

Features

- Two-vane, semi-open, solids handling impeller
- External impeller adjustment
- Abrasion-resistant double mechanical seal
- Quick-disconnect cover plate
- Heavy-duty, volute casing
- Replaceable seal housing
- Replaceable and reversible wear plate
- Solid one-piece flap valve
- Back pullout design
- Multiple drive options
- Extra large diameter shaft

See Bulletin PS-10-9

MF
Solids Handling

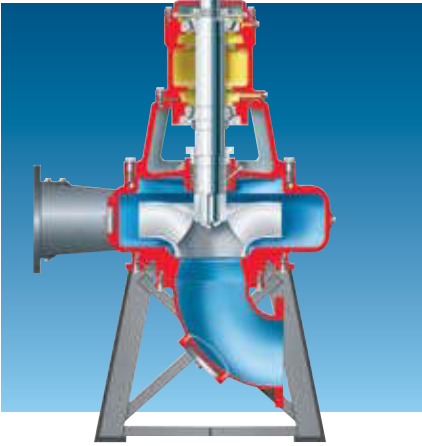

Standards
• Flowserve

Operating Parameters
• Flows to 2275 m³/h (10 000 gpm)
• Heads to 90 m (300 ft)
• Sizes to 400 mm (16 in)

Features
• Variety of nozzle position options
• Direct or independent motor mounting
• Minimal shaft deflection
• Oversized shaft and reduced overhang
• Hardened chrome steel wear rings
• Seal chamber accommodates packing or mechanical seals
• Adjustable impeller clearance
• Shaft sleeve options
– 316 stainless steel
– Hardened chrome steel
• Bearing housing features
– Ball or tapered roller bearings
– Integral jacking bolts for wear ring adjustment
– Accessible lubrication points

Available Configurations
• MF horizontal, end suction
• MFV vertical with motor on separate floor (shown)
• MFC vertical with direct connected motor

See Bulletin PS-10-3

MN
**Large Capacity,
Solids Handling**

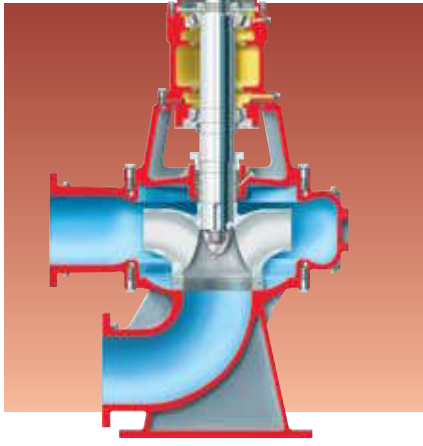

Standards
• Flowserve

Operating Parameters
• Flows to 45 500 m³/h (200 000 gpm)
• Heads to 90 m (300 ft)
• Sizes to 1800 mm (72 in)

Features
• Variety of nozzle position options
• Direct or independent motor mounting
• Minimal shaft deflection
• Oversized shaft and reduced overhang
• Hardened chrome steel wear rings
• Seal chamber accommodates packing or mechanical seals
• Adjustable wear ring clearance
• Shaft sleeve options
– 316 stainless steel
– Hardened chrome steel
• Bearing housing features
– Tapered roller bearings
– Integral jacking bolts for wear ring adjustment
– Accessible lubrication points

Available Configurations
• MN horizontal, end suction
• MNF vertical, bottom suction, direct connected motor
• MNZ vertical, bottom suction, motor on separate floor
• MNC vertical with base elbow, direct connected motor
• MNV vertical with base elbow, motor on separate floor (shown)

See Bulletin PS-10-4

MSX
**Solids Handling,
Submersible**

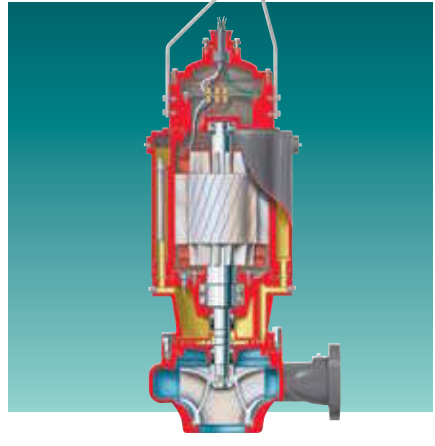

Standards
• Flowserve

Operating Parameters
• Flows to 4545 m³/h (20 000 gpm)
• Heads to 90 m (300 ft)
• Temperatures to 40°C (104°F)
• Discharge sizes from 80 mm (3 in) to 500 mm (20 in)
• Motor to 224 kW (300 hp)
• Solids handling to 80 mm (3 in) diameter spherical

Features
• High-efficiency hydraulics
• EPACT rated motor
• Spike-resistant windings
• Class H rated insulation system
• Dynamically balanced shaft and rotor
• Mounting options
– Wet pit
– Dry pit
– Transportable

Available Configurations
• MSX Series 1: Sizes from 75 mm (3 in) to 150 mm (6 in)
• MSX Series 2/3: Sizes to 500 mm (20 in)

See Bulletin PS-50-2

D800 Series Cast Iron

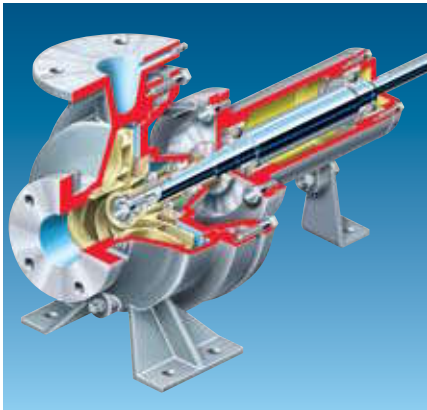

Standards

- Flowserve

Operating Parameters

- Flows to 340 m³/h (1500 gpm)
- Heads to 120 m (395 ft)
- Pressures to 15 bar (220 psi)
- Temperatures to 120°C (250°F)

Features

- High-efficiency closed impeller
- Centerline discharge
- Sealed-for-life, pre-lubricated motor bearings with two-year minimum life
- Renewable wear rings and shaft sleeves
- Pre-set mechanical seal assembly
- Bell type mechanical seal cover
- Standard NEMA C-face motor
- Back pullout design
- Threaded and flanged connections

Available Configurations

- Type D-814 frame mounted
- Type D-824 close coupled
- Type D-834 vertical in-line

See Bulletin PS-10-6

MEN End Suction

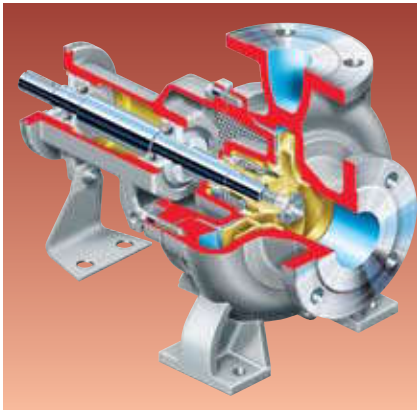

Standards

- DIN 24255
- EN 733
- Flowserve

Operating Parameters

- Flows to 800 m³/h (3520 gpm)
- Heads to 140 m (450 ft)
- Pressures to 16 bar (230 psi)
- Temperatures to 120°C (250°F)

Features

- 33 sizes available
- Volute casing with top discharge
- Dynamically balanced, precision cast closed impeller with extended hub and machined shroud
- Balancing chamber and impeller balance holes minimize axial thrust
- Open seal chamber with integral vortex breaking ribs
- Oversized stainless steel shaft
- Oversized bearings
- Standard case wear rings
- Back pullout design

Related Configurations

- MEN-SP vertical cantilever sump
- MHP high-pressure
- MENBLOC close coupled
- ME horizontal high capacity
- MEV vertical high capacity

See Bulletin PS-10-2

MENBLOC Close Coupled



Standards

- DIN 24255
- EN 733
- Flowserve

Operating Parameters

- Flows to 340 m³/h (1500 gpm)
- Heads to 100 m (330 ft)
- Pressures to 16 bar (230 psi)
- Temperatures to 110°C (230°F)

Features

- Compact, space-saving configuration
- End suction, top discharge, volute casing
- Precision cast and dynamically balanced high-efficiency, closed impeller with extended hub
- Impeller balance chamber and holes for reduced thrust
- Open seal chamber with integral vortex breaking ribs
- Oversized stainless steel shaft
- Oversized bearings
- Standard case wear rings
- Back pullout design
- Baseplate and coupling not required
- CE marked in Europe

Related Configurations

- MEN horizontal end suction
- MEN-SP vertical cantilever sump
- MHP high-pressure
- ME horizontal high capacity
- MEV vertical high capacity

See Bulletin PS-10-2

ME
End Suction



Standards
• Flowserve

Operating Parameters
• Flows to 3000 m³/h (13 200 gpm)
• Heads to 90 m (295 ft)
• Pressures from 4 to 16 bar (58 to 232 psi)
• Temperatures to 120°C (250°F)

Features
• Single volute, end suction casing with tangential discharge
• Back pullout design
• Radial flow impeller shrouded, keyed on shaft
• Impeller balance holes minimize axial thrust
• Bearings
– Radial ball bearing and roller bearings (depending on size)
– Sealed for life for lower frames, rationalized with MEN sizes
– Grease lubricated for higher frames

Related Configurations
• MEV vertical, end suction
• MEN horizontal, end suction (low capacity)
• MHP horizontal, end suction (low capacity, high-pressure)
• DS horizontal, end suction (high capacity)

DS
Double Volute,
End Suction



Standards
• Flowserve

Operating Parameters
• Flows to 5700 m³/h (25 000 gpm)
• Heads to 110 m (350 ft)
• Pressures to 27 bar (400 psi)
• Temperatures to 120°C (250°F)

Features
• Double volute, end suction casing with centerline discharge
• Mechanically balanced, radial flow impeller
• Impeller balance holes minimize axial thrust
• Seal chamber accommodates packing and multiple mechanical seal types
• Back pullout design
• Angular contact thrust bearing and parallel roller radial bearing
• Grease lubrication standard; oil lubrication optional
• Choice of materials – from cast iron to super duplex

Related Configurations
• DSV vertical
• Directional discharge (90° on the right or on the left)
• Centerline mounted

SMP
Standard Motor
End Suction



Standards
• Flowserve

Operating Parameters
• Flows to 135 m³/h (600 gpm)
• Heads to 70 m (220 ft)
• Pressures to 12 bar (175 psi)
• Temperatures from -40°C (-40°F) to 120°C (250°F)

Features
• Glass reinforced polymer, high-efficiency, semi-open or closed impellers standard
• Industry standard NEMA motors
• Stainless steel, self-aligned mechanical seal
• Back pullout design
• Clamp-type mounting plate
• Options
– Cast iron, bronze or 316 stainless steel impellers
– Stub shaft design

Related Configurations
• SMX non-metallic, standard motor pump
• VSMP vertical, standard motor pump

See Bulletin PS-10-26

SMX
Non-Metallic
Standard Motor

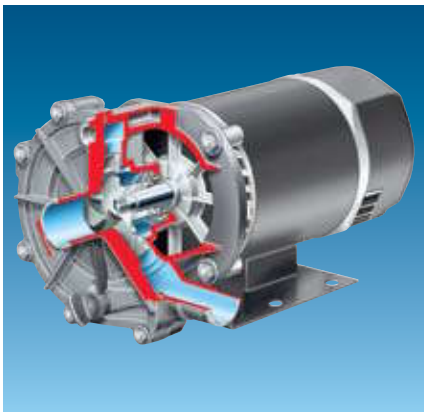

Standards
 • Flowserve

Operating Parameters

- Flows to 25 m³/h (100 gpm)
- Heads to 20 m (60 ft)
- Pressures to 12 bar (175 psi)
- Temperatures to 80°C (180°F)

Features

- Polyphenylene sulfide (PPS) casing, adapter and impeller
- Standard NEMA 56J frame C-faced motor
- Stainless steel, self-aligned mechanical seal
- Back pullout design
- 40 mm (1.5 in) port size for hose connection

Related Configurations

- SMP standard motor pump
- VSMP vertical standard motor pump

See Bulletin PS-10-26

F-Line
End Suction, Multistage

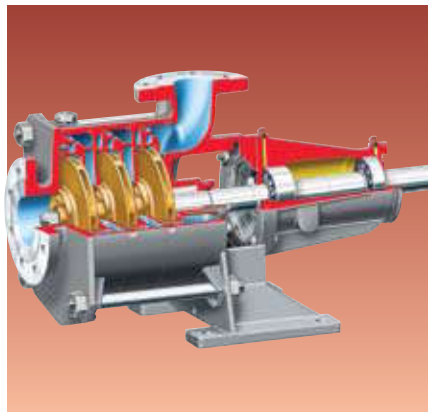

Standards
 • Flowserve

Operating Parameters

- Flows to 500 m³/h (2200 gpm)
- Heads to 250 m (820 ft)
- Discharge pressures to 25 bar (365 psi)
- Temperatures to 105°C (220°F)

Features

- Modular design
 - 8 sizes
 - 15 hydraulics
 - 2 impeller types
- To 9 stages, depending on model and operating speed
- Sleeved shaft under sealing system
- Cast iron EN-GJL 250 pressure casings
- Cast iron EN-GJL 250 or NORYL[®] impellers, depending upon model
- Steel grade C 35 E shaft
- 13% chromium steel sleeve

Available Configurations

- FP horizontal, overhung impeller
- FM horizontal, close coupled
- FD vertical
- FS vertical, suspended shaft wet-pit
- FMD vertical, close coupled
- FAD vertical, rigid coupled

© NORYL is a registered trademark of General Electric Company

MVE
End Suction



Standards
 • Flowserve

Operating Parameters

- Flows to 2700 m³/h (11 890 gpm)
- Heads to 15 m (50 ft)
- Pressures to 7 bar (100 psi)
- Temperatures to 100°C (212°F)

Features

- Single volute casing with end suction and side discharge; top discharge optional
- Mechanically balanced, mixed flow impeller
- Seal chamber accommodates packing and multiple mechanical seal types
- Back pullout design
- Standard angular contact radial and thrust bearings
- Standard grease lubrication; oil lubrication optional
- Choice of materials
 - Cast iron
 - Ni-Resist[®]
 - Bronze
 - Super duplex stainless steel

© N-Resist is a registered trademark of the International Nickel Co., Inc.

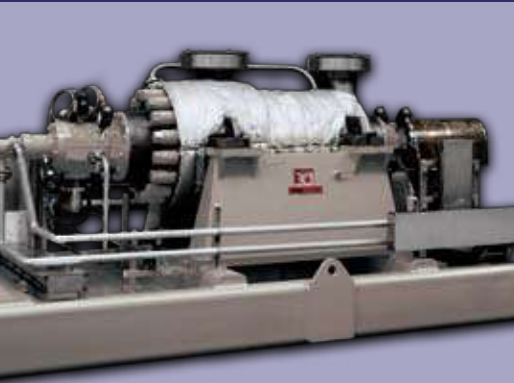

Between Bearings Pumps**Single Case - Axially Split - Single Stage**

LR	28
LNN	28
DVSH	28
LPN	29

Single Case - Axially Split - Multistage

EC	30
UZDL	30
DMX	30

Single Case - Radially Split - Single Stage

HDX	31
HDX-TT	31
DVSR	31

Single Case - Radially Split - Multistage

HED	32
HED-DS	32
WTB	32
WD	33
WDX	33
NM	33
WX	33
CS	34
WXH	34

Double Case

WXB	35
WXB-B	35
WNC	35
CSB	35
CHTA	36
HDB	36
HSB	36
BP	36
WCC	37
HDO	37
HSO	37
WIK	37
WIKO	37



LR Axially Split, Single Stage

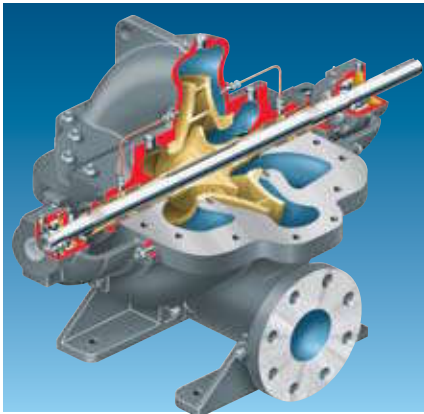

Standards

- Flowsolve

Operating Parameters

- Flows to 2000 m³/h (8800 gpm)
- Heads to 170 m (560 ft)
- Pressures to 21 bar (300 psi)
- Temperatures from -30°C (-20°F) to 150°C (300°F)

Features

- Split case design with lifting lugs
- Low NPSH enclosed double suction impeller
- Flat or raised face suction and discharge flanges to ANSI, DIN and ISO standards
- Oil or grease lubricated radial and thrust bearings
 - Single row, deep groove ball bearings or duplex thrust ball bearings
 - 100 000 hours typical L10 bearing life
- Seal chamber accommodates multiple seal types
- Standard case wear rings; optional serrated groove designs
- Optional impeller wear rings
- Available high performance coatings

Related Configurations

- LRV vertical, axially split, single stage
- LLR axially split, two stage

See Bulletin PS-20-3

LNN Axially Split, Single Stage

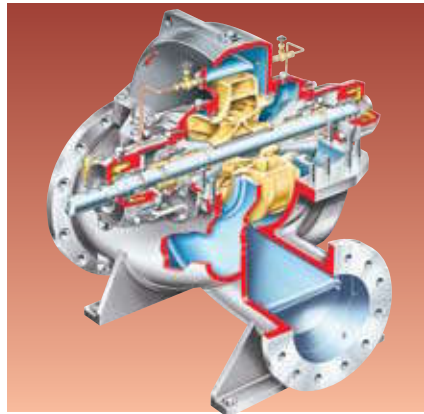

Standards

- Flowsolve

Operating Parameters

- Flows to 30 000 m³/h (132 000 gpm)
- Heads to 300 m (980 ft)
- Pressures to 40 bar (580 psi)
- Temperatures to 140°C (285°F)

Features

- Heavy-duty, double volute casing with side suction and side discharge
- Flanges to ANSI, DIN and ISO standards
- Hydraulically balanced, double suction impeller
- Optimum axial and radial thrust balance
- Standard casing wear rings; optional impeller wear rings
- Seal chamber accommodates packing and multiple mechanical seal types
- 360° supported bearing housing
- Choice of bearings
 - Standard ball radial and ball thrust
 - Optional double row, angular contact thrust bearings
 - Optional sleeve bearings
- Grease lubrication standard; oil mist and bath optional
- Choice of materials

Related Configurations

- LNNV vertical, single stage
- LNNC single stage, bottom suction
- LNE, LNS, LNST and LNGT axially split, single stage

See Bulletin PS-20-1

DVSH (BB1) Axially Split, Single Stage

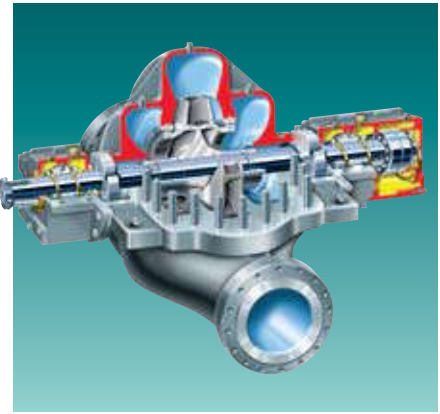
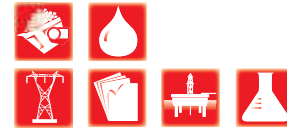

Standards

- ISO 13709/API 610 (BB1), latest ed.

Operating Parameters

- Flows to 12 000 m³/h (52 835 gpm)
- Heads to 565 m (1854 ft)
- Pressures to 150 bar (2175 psi)
- Temperatures to 200°C (400°F)
- Speeds to 6000 rpm

Features

- Double volute casing
- Hydraulically balanced double suction impeller
- ISO 21049/API 682 seal chambers accommodates multiple seal types
- Stiff shaft design
- Baseplate designs and pump packages engineered to contract requirements
- Choice of bearings
 - Ball radial and thrust
 - Sleeve radial and ball thrust
 - Sleeve radial and tilting pad thrust
- Choice of materials
 - Carbon steel
 - 12% chrome
 - Austenitic stainless steels
 - Duplex stainless steels

See Bulletin PS-20-2

LPN (BB1) **Axially Split, Double** **Suction, Single Stage**

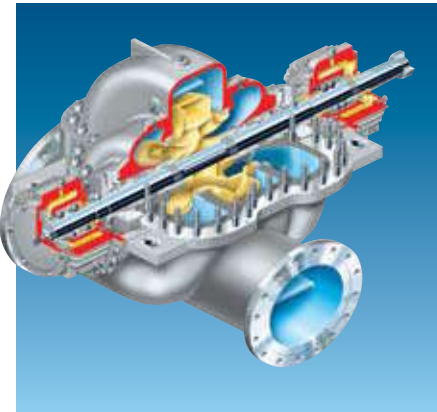

Standards

- ISO 13709/API 610 (BB1), latest ed.

Operating Parameters

- Flows to 15 000 m³/h (65 000 gpm)
- Heads to 250 m (820 ft)
- Pressures to 25 bar (365 psi); 50 bar (725 psi) with LPN-H model
- Temperatures from -80°C (-110°F) to 150°C (400°F)

Features

- Double volute, near-centerline supported casing
- ASME (ANSI) B16.5 Class 150 or Class 300 raised face flanges
- Confined gasket design
- Hydraulically balanced double suction impeller
- ISO 21049/API 682 seal chambers
- Baseplate designs and pump packages engineered to contract
- Heavy-duty, bracketed, 180° supported carbon steel bearing housing
- Standard non-contacting labyrinth seals
- Choice of bearings
 - Ball radial and ball thrust with oil flinger system
 - Split leeve radial and ball thrust with ring oil system
 - Split sleeve radial and tilting pad thrust with pressure lubrication

Other Configurations

- LPN-H high-pressure, double suction
- LPN-V vertical in-line

See Bulletin PS-20-5

EC Axially Split, Multistage



Standards

- Flowsolve

Operating Parameters

- Flows to 2340 m³/h (10 300 gpm)
- Heads to 650 m (2130 ft)
- Pressures to 88 bar (1300 psi)
- Temperatures from -30°C (-20°F) to 150°C (300°F)

Features

- Horizontally split case with integral mounting feet
- In-line mounted impellers
- Rotating assembly balanced as a unit
- Case wear rings standard at impeller eye
- Diaphragm rings standard at impeller back shroud
- Shaft protected by interstage sleeves and packing sleeves
- Seal chambers can accommodate packing or mechanical seals
- Double row anti-friction radial and thrust bearings
- Grease lubrication

UZDL (BB1) Axially Split, Two Stage

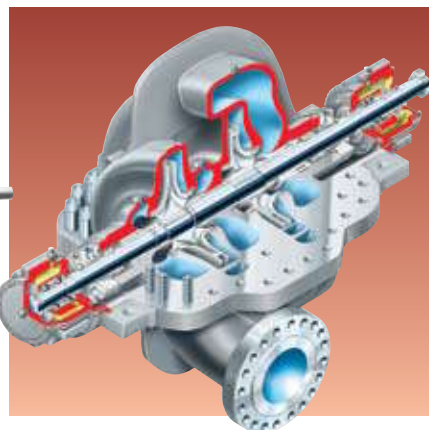

Standards

- ISO 13709/API 610 (BB1), latest ed.

Operating Parameters

- Flows to 2950 m³/h (13 000 gpm)
- Heads to 685 m (2250 ft)
- Pressures to 64 bar (910 psi)
- Temperatures to 200°C (400°F)
- Speeds to 2000 rpm

Features

- Double volute hydraulic passages
- ISO 21049/API 682 seal chambers
- Shaft options
 - Double extension for connection to auxiliary pumps or hydraulic turbines
 - Special shaft end machining for hydraulic fitted couplings
- Baseplate designs and pump packages engineered to contract
- Dynamic balancing and TIR verifications on assembled rotors
- Choice of bearings
 - Ball radial and thrust
 - Sleeve radial and ball thrust
 - Sleeve radial and tilting pad thrust
 - Tilting pad radial and tilting pad thrust
- Choice of materials
 - Carbon steel
 - 12% chrome
 - Austenitic stainless steels
 - Duplex stainless steels
 - Monel®

See Bulletin PS-30-2

© Monel is a registered trademark of International Nickel Co.

DMX (BB3) Axially Split, Multistage

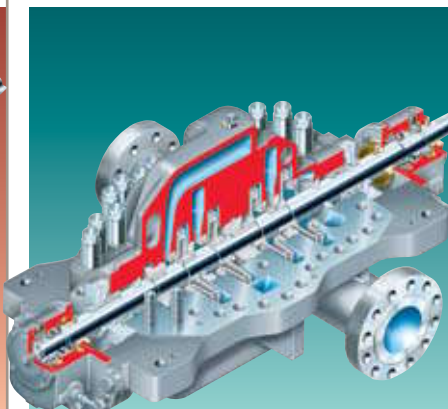

Standards

- ISO 13709/API 610 (BB1), latest ed.

Operating Parameters

- Flows to 2950 m³/h (13 000 gpm)
- Heads to 2130 m (7000 ft)
- Pressures to 275 bar (4000 psi)
- Temperatures to 200°C (400°F)
- Speeds to 6000 rpm

Features

- Double volute hydraulic passages
- Renewable case and impeller wear rings
- ISO 21049/API 682 seal chambers
- Axially split center bushing
- Shaft options
 - Double extension for connection to auxiliary pumps or hydraulic turbines
 - Special shaft end machining for hydraulic fitted couplings
- Interstage take-off option
- Baseplate designs and pump packages engineered to contract
- Dynamic balancing and TIR verifications on assembled rotors
- Choice of bearings
 - Ball radial and thrust
 - Sleeve radial and ball thrust
 - Sleeve radial and tilting pad thrust
- Choice of bearing lubrication systems
- Choice of bearing cooling systems
- Choice of materials

See Bulletin PS-30-3

HDX (BB2)
Radially Split,
Double Suction

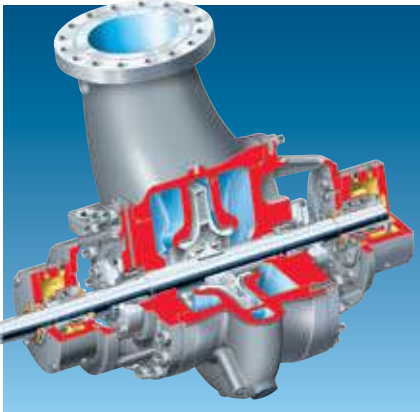

Standards

- ISO 13709/API 610 (BB2), latest ed.

Operating Parameters

- Flows to 4100 m³/h (18 000 gpm)
- Heads to 450 m (1500 ft)
- Pressures to 42 bar (610 psi);
100 bar (1450 psi) with HDX-H model
- Temperatures to 450°C (850°F)

Features

- Double-volute, centerline supported, self-venting casing
- ASME (ANSI) B16.5 Class 300 flanges; optional Class 600 and 900 flanges
- Dynamically balanced, double suction impeller
- Stiff shaft design
- ISO 21049/API 682 seal chambers
- Standard dual, single-row, back-to-back mounted, angular contact type thrust bearing
- Bearing options
 - Sleeve radial and ball thrust
 - Sleeve radial and tilting pad thrust
 - Lubrication systems available
- 360° supported bearing housing
- Double case covers

Related Configurations

- HDX-H high-pressure, radially split, double suction
- In-line side nozzles
- Same-side nozzles (90° rotated)

See Bulletin PS-20-4

HDX-TT (BB2)
Radially Split, Power
Recovery Turbine

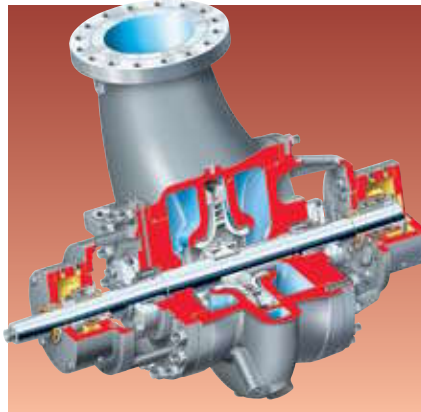

Standards

- ISO 13709/API 610 (BB2), latest ed.

Operating Parameters

- Flows to 4100 m³/h (18 000 gpm)
- Heads to 760 m (2500 ft)
- Pressures to 100 bar (1450 psi)
- Temperatures to 450°C (850°F)

Features

- Double volute, centerline supported, self-venting casing with diffuser
- ASME (ANSI) B16.5 Class 300 flanges; optional Class 600 and 900 flanges
- Dynamically balanced, double suction, radial inflow turbine runner
- Stiff shaft design
- ISO 21049/API 682 seal chambers
- Standard dual, single-row, back-to-back mounted, angular contact type thrust bearing
- Bearing options
 - Sleeve radial and ball thrust
 - Sleeve radial and tilting pad thrust
 - Lubrication systems available
- 360° supported bearing housing
- Double case covers

Other Configurations

- High-pressure
- In-line side nozzles
- Side-side nozzles (90° rotated)

DVSR
Radially Split, Volute
Casing, Single Stage

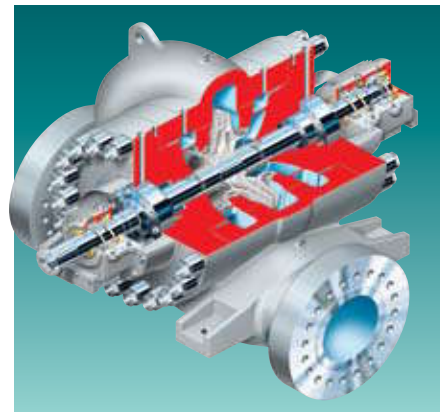

Standards

- ISO 13709/API 610 (BB2), latest ed.

Operating Parameters

- Flows to 3635 m³/h (16 000 gpm)
- Heads to 250 m (820 ft)
- Pressures to 260 bar (3750 psi)
- Temperatures to 200°C (400°F)
- Speeds to 4000 rpm

Features

- Double volute casing
- Hydraulically balanced double suction impeller
- Staggered vane impellers
- Stiff shaft design
- ISO 21049/API 682 seal chambers
- Baseplate designs and pump packages engineered to contract
- Choice of bearings
 - Sleeve radial and ball thrust
 - Sleeve radial and tilting pad thrust
 - Tilting pad radial and tilting pad thrust
- Choice of materials
 - Carbon steel
 - 12% chrome

HED (BB2) Radially Split, Two Stage



Standards

- ISO 13709/API 610 (BB2), latest ed.

Operating Parameters

- Flows to 1000 m³/h (4400 gpm)
- Heads to 650 m (2100 ft)
- Pressures to 120 bar (1750 psi)
- Temperatures to 450°C (850°F)

Features

- Heavy-duty, double volute casing with 180° staggered volutes
- Top-top nozzle configuration
- ISO 13709/API 682 seal chambers
- Dynamic balancing and TIR verifications on assembled rotating element
- Baseplate designs and pump packages engineered to contract
- Choice of bearings
 - Ball radial and thrust
 - Sleeve radial and ball thrust
 - Sleeve radial and tilting pad thrust
- Choice of materials
 - Carbon steel
 - 12% chrome
 - Austenitic stainless steel
 - Duplex stainless steel
 - Monel lining

Other Configurations

- HED-DS radially split, double suction, two stage
- In-line side nozzles
- Same-side nozzles
- High-pressure

See Bulletin PS-30-4

HED-DS (BB2) Radially Split, Double Suction, Two Stage

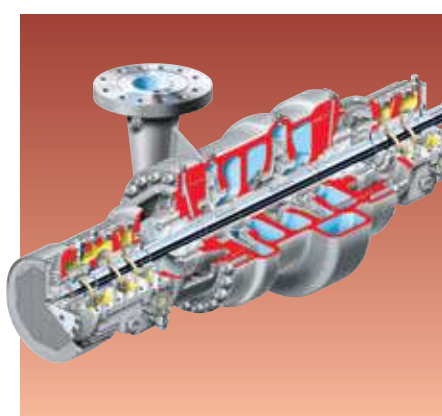

Standards

- ISO 13709/API 610 (BB2), latest ed.

Operating Parameters

- Flows to 2000 m³/h (8800 gpm)
- Heads to 750 m (2460 ft)
- Pressures to 120 bar (1750 psi)
- Temperatures to 450°C (850°F)

Features

- Double suction first stage impeller
- Heavy-duty, double volute casing with 180° staggered volutes
- Top-top nozzle configuration
- ISO 13709/API 682 seal chambers
- Dynamic balancing and TIR verifications on assembled rotating element
- Baseplate designs and pump packages engineered to contract
- Choice of bearings
 - Ball radial and thrust
 - Sleeve radial and ball thrust
 - Sleeve radial and tilting pad thrust
- Choice of materials
 - Carbon steel
 - 12% chrome
 - Austenitic stainless steel
 - Duplex stainless steel
 - Monel lining

Other Configurations

- HED radially split, two stage
- In-line side nozzles
- Same-side nozzles
- High-pressure

See Bulletin PS-30-4

WTB (BB2) Radially Split, Double Suction, Three Stage

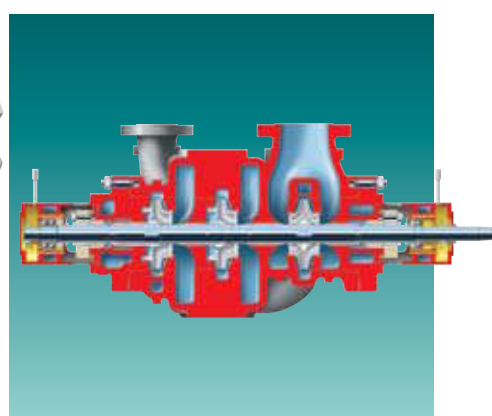

Standards

- ISO 13709/API 610 (BB2), latest ed.

Operating Parameters

- Flows to 1400 m³/h (6165 gpm)
- Heads to 1100 m (3610 ft)
- Pressures to 108 bar (1565 psi)
- Temperatures to 430°C (800°F)
- Speeds to 3600 rpm

Features

- Meets intent of key ISO/API requirements
- Heavy-duty, centerline supported, dual volute casing with integral crossover
- ASME (ANSI) B16.5 Class 300 flanges; Class 600 and 900 flanges optional
- Dynamically balanced, double suction first stage impeller; single suction on smallest three-stage only
- Balance holes on second and third stage impellers
- ISO 21049/API 682 seal chambers
- 360° supported, carbon steel bearing housing
- Choice of bearings
 - Sleeve radial and ball thrust
 - Sleeve radial and tilting pad thrust
 - Dual, single row, angular contact anti-friction thrust bearings installed back-to-back and single row, deep groove anti-friction radial bearing

Available Configurations

- WTB three stage, double suction
- WTB two stage, single suction
- WTB two stage, double suction

See Bulletin PS-30-14

WD and WDX
Radially Split, Multistage,
Ring Section

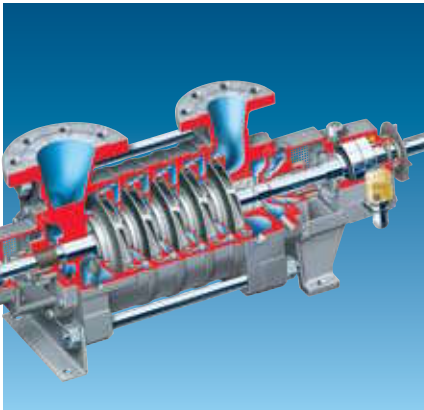

Standards
 • Flowserve

Operating Parameters

- Flows to 190 m³/h (800 gpm)
- Heads to 700 m (2300 ft)
- Pressures to 75 bar (1090 psi)
- Temperatures to 210°C (410°F)

Features

- Multivane diffusers
- Identical radially-split ring section sets
- O-ring interstage sealing arrangement
- Deep-groove ball bearing design
- Angular contact, double row thrust bearing
- 360° machine registered bearing housing fits
- Dynamically balanced, precision machined enclosed impellers
- Packing or mechanical sealing
- Options
 - Multiple flange orientations
 - End suction design with product lubricated sleeve bearing
 - Radial suction design with product lubricated sleeve bearing
 - Inducer

NM
Radially Split,
Multistage, Ring Section



Standards
 • Flowserve

Operating Parameters

- Flows to 3 000 m³/h (13 210 gpm)
- Heads to 500 m (1640 ft)
- Pressures to 60 bar (870 psi)
- Temperatures to 140°C (285°F)

Features

- Modular design
 - 15 sizes
 - 22 hydraulics
- Low NPSH suction volute design
- Machined impeller shrouds for increased efficiency
- Impeller balance holes minimize axial thrust
- Shrouded diffusers with return guide vanes minimize radial thrust
- Removable seal housings accommodate gland packing and mechanical seals
- Standard cast iron construction; high alloy construction available

Other Configurations

- NMV vertical, multistage ring section
- NMD vertical, multistage ring section
- NM-S vertical, suspended shaft wet pit
- NMAD vertical, rigid shaft coupling

WX
Radially Split,
Multistage, Ring Section

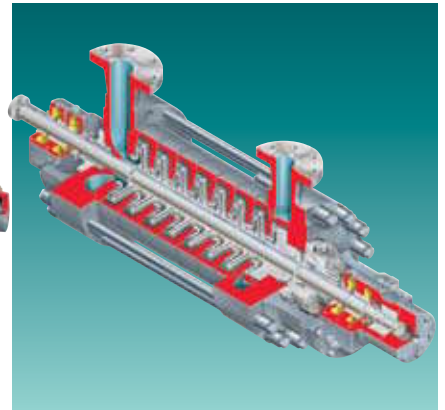

Standards
 • Flowserve

Operating Parameters

- Flows to 300 m³/h (1320 gpm)
- Heads to 1200 m (3940 ft)
- Pressures to 150 bar (2175 psi)
- Temperature from -50°C (-58°F) to 200°C (400°F)

Features

- Separate cast diffusers and channel rings
- Centerline mounted, self-venting casing
- Top/top nozzles
- Interstage O-ring seals
- Individual impeller balance
- Precision fit rotor
- Optional inducer for low NPSHr

CS
**Radially Split,
 Multistage, Ring Section**

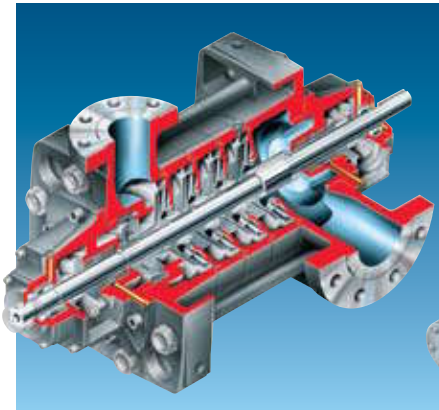

- Standards**
- Flowsolve

Operating Parameters

- Flows to 450 m³/h (1980 gpm)
- Heads to 1250 m (4110 ft)
- Pressures to 125 bar (1800 psi)
- Temperatures from -30°C (-20°F) to 120°C (248°F)

Features

- Separate cast diffusers and channel rings
- Secondary O-ring seals
- Complete radial balance
- Press fit stationary wear parts
- Balance disc wear indicator
- Disc balancing device
- Centerline or foot mounted casing
- Optional nozzle orientation
- Choice of bearings
 - Ball radial and thrust
 - Sleeve radial and ball thrust
 - Sleeve radial and tilting pad thrust

WXH
**Radially Split, Multistage,
 High Pressure,
 Ring Section**

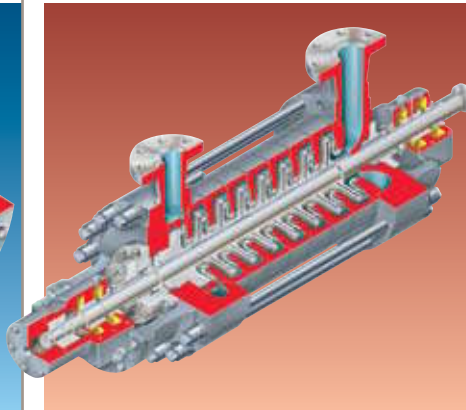

- Standards**
- Flowsolve

Operating Parameters

- Flows to 900 m³/h (4000 gpm)
- Heads to 2650 m (8700 ft)
- Pressures to 250 bar (3625 psi)
- Temperatures to 250°C (480°F)

Features

- Cast suction and discharge heads with integral nozzles
- Single or double suction first stage impeller designs
- Investment cast diffusers and return channel hydraulic passages
- Compression type interstage O-ring
- Separate, high strength sub-base
- Replaceable stationary wear parts mounted in the diffusers
- Standard flanged balance drum with serrated running clearances; optional straight balance drum
- Seal chamber accepts single, double and tandem mechanical seals
- Large diameter shaft with staggered impeller and balancing device keyways
- No pre-warming required
- Chrome steel nozzles
- Choice of bearings
 - Ball radial and thrust
 - Sleeve radial and ball thrust
 - Sleeve radial and tilting pad thrust

See Bulletin PS-30-1

**WXB and WXB-B
Diffuser Casing,
Multistage, Process Barrel**

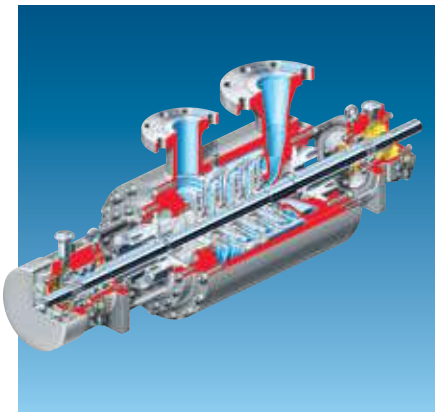

Standards

- ASME Section VIII

Operating Parameters

- Flows to 300 m³/h (1320 gpm)
- Heads to 1200 m (3940 ft)
- Pressures to 150 bar (2175 psi)
- Temperatures to 200°C (390°F)

Features

- Diffuser case construction
- Removeable cartridge type inner case sub-assembly
- Large eye first stage impeller
- Low flow high head Barske impeller on WXB-B
- Patented balancing device
- Sleeve mounted deep groove radial and back-to-back mounted angular contact bearings
- High-capacity, antifriction type thrust bearing
- Bearing lubrication system with oil bath, constant level oiler and sight glass
- Renewable casing and impeller rings
- High shaft diameter/bearing span ratio
- Options
 - Hydrodynamic sleeve type radial bearings
 - Thrust bearing cooling system (air)
 - Labyrinth type end seals

Available Configurations

- WXB: standard hydraulics
- WXB-B: low flow, high head hydraulics

See Bulletins PS-30-6 and PSS-30-6.1

**WNC
Diffuser Casing,
Multistage, Utility Barrel**

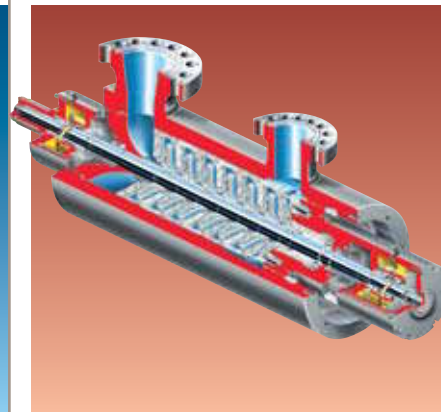

Standards

- ASME Section VIII

Operating Parameters

- Flows to 1400 m³/h (6200 gpm)
- Pressures to 350 bar (5075 psi)
- Temperatures to 200°C (390°F)

Features

- Diffuser case construction
- Shear ring design
- High-strength forged steel barrel; alloy barrels available
- Removeable cartridge type inner case sub-assembly
- Shear ring barrel closing system
- Single or double suction first stage impeller
- Standard antifriction or sleeve type radial bearings
- High-capacity antifriction type thrust bearing; tilting pad thrust bearing available
- Renewable casing rings
- Straight balance drum forged from hardened stainless steel
- Chrome plated shafting under journal bearings
- Ground forged steel shafting

Related Configurations

- WNC-HP high-pressure, diffuser casing, multistage, utility barrel

See Bulletin PS-30-12

**CSB
Diffuser Casing,
Multistage, Utility Barrel**

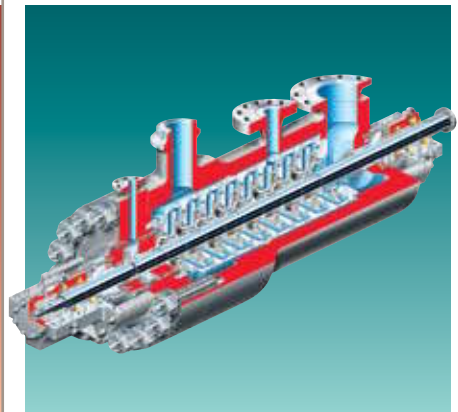

Standards

- ASME Section VIII

Operating Parameters

- Flows to 1500 m³/h (6600 gpm)
- Discharge pressures to 300 bar (4350 psi)
- Temperatures to 250°C (480°F)
- Speeds to 8000 rpm

Features

- Internal casing with segmented stage elements
- Diffuser-guide vane construction
- Precision cast in-line impellers of high-quality chrome steel
- Heavy-duty barrel with forged steel discharge cover
- Fully enclosed or shrouded precision cast diffusers on high-energy applications
- Tilt pad thrust and tri-land radial bearings
- Renewable casing rings and sleeves
- Flanged balance drum forged from hardened stainless steel; straight drum optional
- Chrome plated shafting under journal bearings
- Ground forged steel shafting

See Bulletin PS-30-12

CHTA **Diffuser Casing,** **Multistage, Utility Barrel**

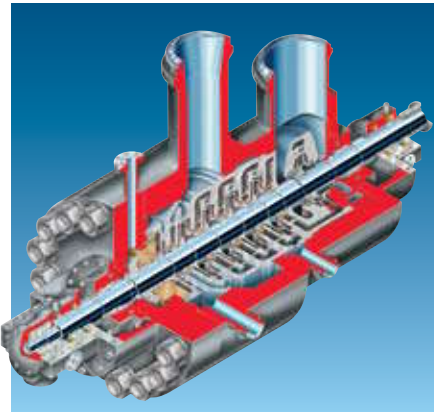

Standards

- ASME Section VIII

Operating Parameters

- Flows to 5250 m³/h (23 000 gpm)
- Heads to 4300 m (14 000 ft)
- Discharge pressures to 450 bar (6525 psi)
- Temperatures to 250°C (480°F)
- Speeds to 6000 rpm

Features

- Internal casing with segmented stage elements
- Diffuser-guide vane construction
- Precision cast in-line impellers of high-quality chrome steel
- Heavy-duty barrel with forged steel discharge cover
- Fully enclosed or shrouded precision cast diffusers on high-energy applications
- Balance drum and sleeve made from hardened stainless steel forgings
- Tilt pad thrust and tri-land radial bearings
- Serrated running fits
- Renewable casing rings and sleeves
- Flanged balance drum design
- Chrome plated shafting under journal bearings
- Ground forged steel shafting

See Bulletin PS-30-12

HDB and HSB **Volute Casing,** **Multistage, Utility Barrel**

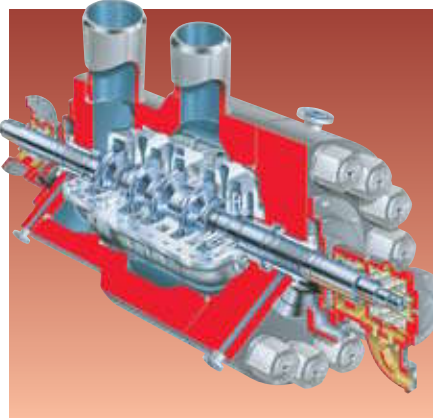

Standards

- ASME Section VIII

Operating Parameters

- Flows to 4000 m³/h (17 600 gpm)
- Heads to 4300 m (14 000 ft)
- Discharge pressures to 450 bar (6525 psi)
- Temperatures to 425°C (800°F)
- Speeds to 9000 rpm

Features

- Axially split inner casing
- Dual volute design with symmetrical upper and lower halves
- Opposed impellers
- Heavy-duty forged steel barrel and discharge cover
- Individually mounted and secured impellers
- Dynamic balancing and TIR verifications on assembled rotor
- One full pressure sealing to atmosphere and one full pressure sealing to suction
- Minimal pressure breakdowns across running clearances
- Sleeve radial and tilting pad thrust bearings
- Baseplate designs and pump packages engineered to contract requirements

See Bulletin PS-30-12

BP (BB5) **Diffuser Casing,** **Multistage, Process Barrel**

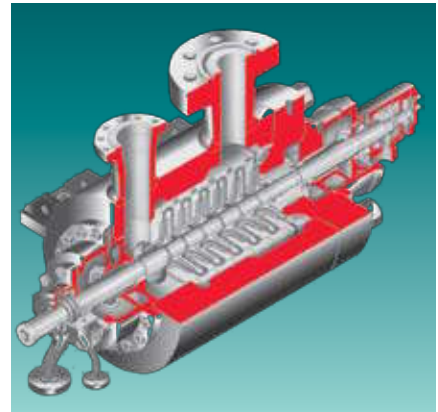

Standards

- ISO 13709/API 610 (BB5), latest ed.

Operating Parameters

- Flows to 1050 m³/h (4620 gpm)
- Heads to 3500 m (11 480 ft)
- Discharge pressures to 295 bar (4260 psi)
- Temperatures to 425°C (800°F)
- Speeds to 6000 rpm

Features

- Diffuser, guide-vane style inner casing with segmented stage elements
- Inner casing bolted head at one end
- Heavy-duty barrel with forged steel discharge cover
- Multi-vane diffuser and channel ring design
- Precision cast diffusers
- Precision cast keyed impellers; optional shrink fit impellers for high-speed or high-temperature service
- Single or double suction first stage impeller
- Straight style balance drum
- Forged shaft; optional stepped shaft for high speed or high-temperature service
- Choice of bearings
 - Ball radial and ball thrust with oil flinger lubrication system
 - Sleeve radial and tilting pad thrust bearings with pressure lubrication system

See Bulletin PS-30-11

**WCC (BB5)
Diffuser Casing,
Multistage, Process Barrel**

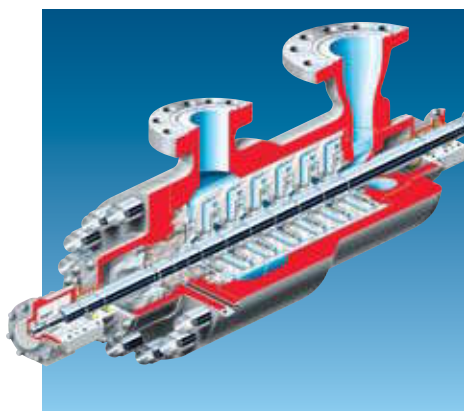

Standards

- ISO 13709/API 610 (BB5), latest ed.

Operating Parameters

- Flows to 1000 m³/h (4400 gpm)
- Heads to 2800 m (9200 ft)
- Discharge pressures to 275 bar (3987 psi)
- Temperatures to 425°C (800°F)
- Speeds to 3580 rpm; 6000 rpm with high-speed option

Features

- Internal casing with segmented stage elements
- Diffuser-guide vane construction
- Multi-vane diffuser-channel ring collectors
- Precision cast chrome steel in-line impellers
- Single suction or double suction first stage impeller
- Heavy-duty barrel with discharge cover
- Removable cartridge type inner case sub-assembly
- Straight or flanged balance drum with serrated running surfaces
- Tilt pad thrust and heavy-duty journal bearings
- Force feed lubricated bearings
- Precision-ground forged steel shafting

See Bulletin PS-30-7

**HDO and HSO (BB5)
Volute Casing, Multistage,
Process Barrel**

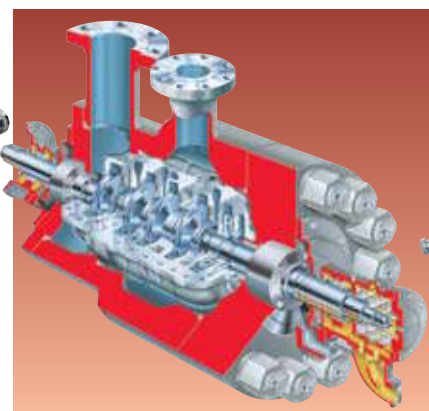

Standards

- ISO 13709/API 610 (BB5), latest ed.

Operating Parameters

- Flows to 4000 m³/h (17 600 gpm)
- Heads to 5365 m (16 000 ft)
- Discharge pressures to 450 bar (6525 psi)
- Temperatures to 425°C (800°F)
- Speeds to 9000 rpm

Features

- Dual volute, axially split inner casing with opposed grouped impellers
- Heavy-duty barrel with forged steel discharge cover
- Symmetrical upper and lower half inner volutes
- Individually mounted and secured impellers
- Dynamic balancing and TIR verifications on assembled rotor
- One full pressure sealing to atmosphere and one full pressure sealing to suction
- Sleeve radial and tilting pad thrust bearings
- Baseplate designs and pump packages engineered to contract requirements

Other Configurations

- Coke crusher (for most sizes)

See Bulletin PS-30-8

**WIK and WIKO (BB5)
Diffuser Casing,
Multistage, Process Barrel**

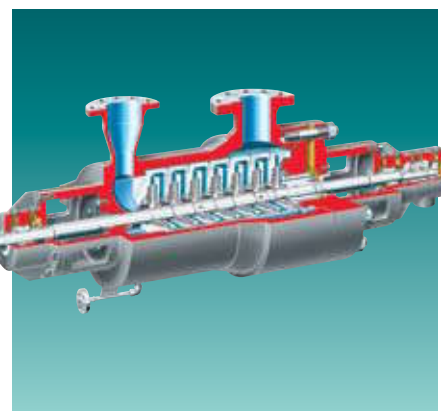

Standards

- ISO 13709/API 610 (BB5), latest ed.

Operating Parameters

- Flows to 4000 m³/h (17 610 gpm)
- Heads to 7000 m (23 000 ft)
- Discharge pressures to 650 bar (9425 psi)
- Temperatures to 450°C (840°F)
- Speeds to 13 000 rpm

Features

- Radially split inner casings
- Multi-vane diffuser and channel ring design
- Tandem or imposed impellers
- Inner casing with a bolted head at one end
 - Optional cartridge element design
 - Optional shear ring design
- Heavy-duty forged steel barrel casing and discharge head
- Precision cast and milled diffusers
- Precision cast impellers
- Shrink fit and double-keyed impellers
- Straight style balance drum
- Tilt pad thrust and sleeve radial bearings
- Large diameter shaft stepped at each impeller and balance drum
- NEMA taper shaft extension

Available Configurations

- WIK: tandem impellers
- WIKO: opposed impellers
- Coke crusher (for most sizes)

See Bulletin PS-30-9



Vertical Pumps**Wet Pit**

WUJ	40
VTP	40
QL	40
QLQ	40
VCT	41
AFV	41
CVP	41

Double Case

QLC	42
QLQC	42
VPC	42
WUC	42
APKD	43

Submersible

Pleuger SUBM	44
Byron Jackson SUBM	44
MSX	44

Slurry and Solids Handling

MVX	45
MFV	45
MNV	45
FRBHJC	46
MJ	46
MJC	46
RJ	46
RJC	46
Terra-Titan	47
MSX	47
Drain-Titan	47

Sump

CPXV Chemical Sump	48
ESP3 Chemical Sump	48
PolyChem VGRP	48
Drain-Titan	49
VSMP	49
ECPJ	49



WUJ (VS1)
Vertical Lineshaft,
Multistage



Standards

- ISO 13709/API 610 (VS1), latest ed.
- ASME Sections VIII and IX
- Directive 94/9/EC (ATEX 100)

Operating Parameters

- Flows to 3000 m³/h (13 200 gpm)
- Heads to 2000 m (6560 ft)
- Pressures to 200 bar (2900 psi)
- Temperatures from -200°C (-328°F) to 350°C (660°F)

Features

- Radial or mixed flow hydraulics
- Multivane diffuser design
- Optional axial thrust tilting pad bearing configuration
- Stiff shaft design
- ISO 21049/API 682 seal chamber accommodates multiple seal types
- Flanged spacer type coupling
- Screen-type, non-sparking coupling guard
- Casing and impeller wear rings
- Centerline aligned and flanged columns
- Reinforced motor stand
- Optional inducer

Related Configurations

- WUC (VS6) double case, multistage

See Bulletin PS-40-8

VTP
Vertical Turbine

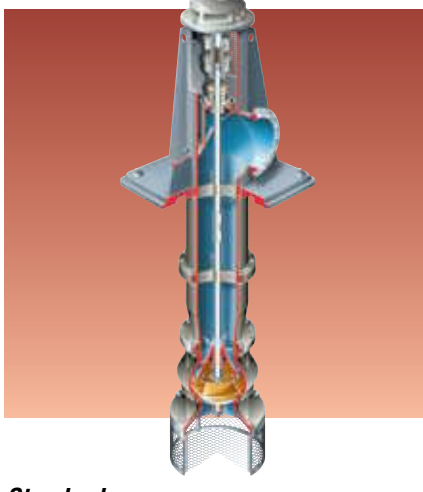

Standards

- Flowserve

Operating Parameters

- Flows to 13 600 m³/h (60 000 gpm)
- Heads to 700 m (2300 ft)
- Pressures to 100 bar (1450 psi)
- Temperatures from -45°C (-50°F) to 300°C (570°F)
- Sizes from 150 mm (6 in) to 1375 mm (55 in)
- Settings to 365 m (1200 ft)

Features

- Above- or below-grade discharge
- Enclosed or semi-open impellers
- Open or enclosed lineshaft construction
- Product or enclosed oil lubrication
- Flanged or threaded column pipe
- High-pressure stuffing box
- Rigid, adjustable coupling
- Drive options
 - Hollow shaft or solid shaft motor
 - Dry or submersible electric motors
 - Variable speed drives
 - Engine with right angle gear
 - Steam turbine
- Options
 - Thrust balanced impeller
 - O-ring bowl
 - Adjustable flanged coupling

Related Configurations

- VTP molten salt design
- VPC vertical turbine, double case

See Bulletin PS-40-7

QL and QLQ
Vertical, Double Suction,
Twin Volute

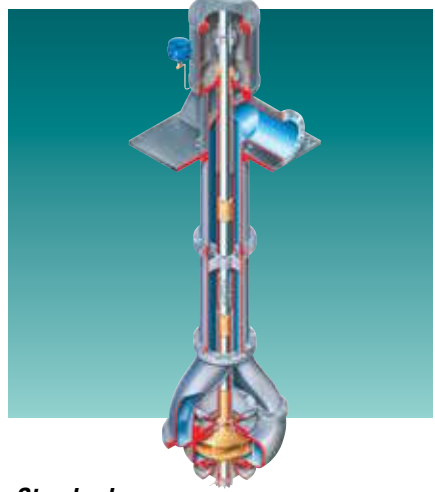

Standards

- Flowserve
- ASME Sections VIII and IX

Operating Parameters

- Flows to 25 000 m³/h (110 000 gpm)
- Heads to 500 m (1640 ft)
- Pressures to 70 bar (1015 psi)
- Temperatures to 200°C (400°F)
- Column sizes to 1500 mm (48 in)

Features

- Heavy-wall, twin-volute casing
- Double suction (first stage) impeller
- Open lineshaft standard; enclosed lineshaft optional
- Heavy-duty discharge head
- Sealed for life bottom bearing
- Options
 - ISO 13709/API 610 (VS2), latest ed., and Directive 94/9/EC (ATEX 100) compliant configurations
 - Vertical solid shaft or hollow shaft motors with thrust bearing
 - Oiler and solenoid switch for pump bearing lubrication
 - Water, grease or oil lubricant
 - Lubrication lines for bottom bearing
 - Antifriction (self-lubricated) or tilting pad axial thrust bearing assembly
 - Rigid, adjustable spacer coupling

Available Configurations

- QL single stage
- QLQ multistage
- QLC double case, single stage
- QLQC double case, multistage

See Bulletin PS-40-4

VCT
Vertical, Mixed Flow



Standards

- Hydraulic Institute
- AWWA

Operating Parameters

- Flows to 181 700 m³/h (800 000 gpm)
- Heads to 110 m (350 ft)
- Sizes from 1200 mm (48 in) to 3380 mm (133 in)

Features

- Five-mitered elbow discharge head with above- or below-grade discharge
- Pullout or non-pullout construction
- Flanged outer column with integral bearing bracket
- Enclosed or semi-open impellers
- Oil, fresh water or self-lubricating column construction
- Seal chamber accepts packing or mechanical seal
- Three-piece rigid, adjustable motor coupling
- Shaft sleeves under the bearings and seal chamber
- Options
 - Discharge head with integral axial thrust bearing assembly
 - Cast or fabricated bowl assembly
 - Integrated suction bell bearing bracket
 - Multiple stages
 - Thrust collar
 - Sand cap
- Engineered to customer specifications

See Bulletin PS-40-6

AFV
Vertical, Axial Flow



Standards

- Flowserve

Operating Parameters

- Flows to 181 700 m³/h (800 000 gpm)
- Heads to 11 m (35 ft)
- Speeds to 1770 rpm
- Sizes from 200 mm (8 in) to 3.1 m (123 in)
- Settings to 8 m (25 ft)

Features

- Three- or four-vane axial flow design
- Cast or fabricated bowl assembly
- Flanged outer column pipe with integral bearing bracket
- Oil, fresh water or self-lubricating lineshaft construction
- Fabricated discharge with mitered elbow
- Above- or below-ground discharge
- Multiple drive options
 - Solid or hollow shaft motor
 - Steam turbine
 - Diesel engine
- Options
 - Casing liners
 - Integral axial thrust bearing assembly

See Bulletin PS-40-3

CVP
Vertical, Concrete Volute

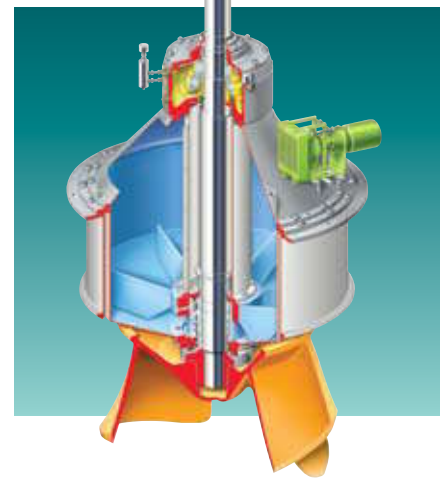

Standards

- Flowserve
- Hydraulic Institute

Operating Parameters

- Flows to 115 000 m³/h (500 000 gpm)
- Heads to 45 m (147 ft)

Features

- Vertical dry-pit design
- Removable metallic pump pullout unit within a concrete volute
- Suction bell connected to preformed high efficiency, vortex-free concrete suction box
- Open mixed flow and closed mixed flow impeller options
- Dry shaft design
- No submerged bearings
- Bearings and sealing systems easily accessible
- Prefabricated concrete segments
- Highly corrosion and erosion resistant
- Liquidyne® or mechanical shaft seal
- Inflatable static seal
- Engineered to customer specifications

Available Configurations

- BSV open mixed flow impeller design
- BCV closed mixed flow impeller design

See Bulletin PS-40-1

© Liquidyne is a registered trademark of IHC

QLC and QLQC
Vertical Double Case,
Double Suction,
Twin Volute

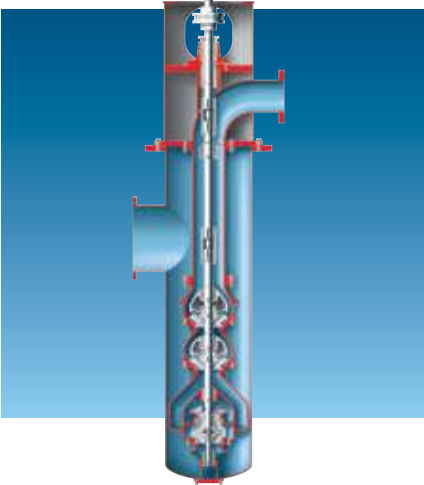

Standards

- Flowsolve
- ASME Sections VIII and IX

Operating Parameters

- Flows to 25 000 m³/h (110 000 gpm)
- Heads to 500 m (1640 ft)
- Pressures to 70 bar (1015 psi)
- Temperatures from -45°C (-50°F) to 200°C (400°F)

Features

- Double case construction
- Heavy-wall twin-volute casing
- Double suction (first stage) impeller
- Open lineshaft construction
- Seal chamber accommodates cartridge style single, dual unpressurized and dual pressurized mechanical seals
- Heavy-duty discharge head
- Options
 - ISO 13709/API 610 (VS7), latest ed., compliant designs
 - Directive 94/9/EC (ATEX 100) available
 - Vertical solid shaft or hollow shaft motors with thrust bearing
 - Antifriction (self-lubricated) or tilting pad axial thrust bearing assembly
 - Rigid, adjustable spacer coupling

Available Configurations

- QLC double case, single stage
- QLQC double case, multistage
- QL single stage
- QLQ multistage

See Bulletin PS-40-4

VPC
Vertical Turbine,
Double Case



Standards

- ASME Sections VIII and IX
- Hydraulic Institute
- AWWA

Operating Parameters

- Flows to 13 600 m³/h (60 000 gpm)
- Heads to 1070 m (3500 ft)
- Pressures to 100 bar (1450 psi)
- Temperatures from -45°C (-50°F) to 230°C (450°F)

Features

- Diffuser design
- Above- or below-grade discharge
- ASME Class 150 or 300 slip-on flanges
- Single or multistage designs
- Enclosed or semi-open impellers
- Large eye first stage impeller
- Product or oil bearing lubrication
- Flanged column pipe
- High-pressure stuffing box
- Rigid, adjustable flanged coupling
- Drive options
 - Hollow shaft or solid shaft motor
 - Variable speed drive
 - Engine with right angle gear
 - Steam turbine
- Other options
 - Integral axial thrust bearing assembly
 - O-ring construction
 - Keyed impellers
 - Bowl and impeller wear rings

Related Configurations

- VTP vertical turbine

See Bulletin PS-40-7

WUC (VS6)
Vertical, Double Case,
Multistage

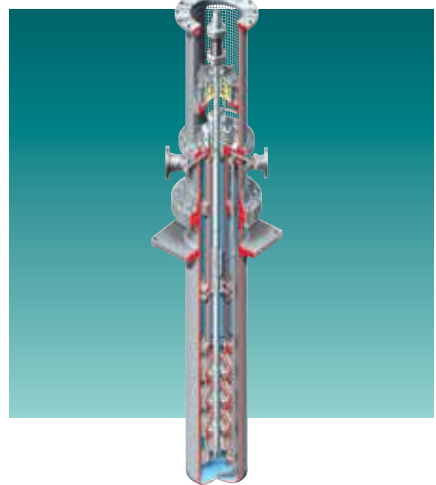

Standards

- ISO 13709/API 610 (VS6), latest ed.
- ASME Sections VIII and IX
- German Pressure Vessel Association (AD)
- British Standard BS 5500
- Compliance with Pressure Equipment Directive 97/23/EC

Operating Parameters

- Flows to 3000 m³/h (13 200 gpm)
- Heads to 2000 m (6560 ft)
- Pressures to 200 bar (2900 psi)
- Temperatures from -200°C (-328°F) to 350°C (660°F)

Features

- Radial or mixed flow hydraulics
- Low suction-velocity can design
- Optional axial thrust tilting pad bearing configuration
- Stiff shaft design
- ISO 21049/API 682 seal chamber accommodates multiple seal types
- Flanged spacer type coupling
- Screen-type, non-sparking coupling guard
- Inside drain line
- Casing and impeller wear rings
- Reinforced motor stand
- Optional inducer

Related Configurations

- WUJ (VS1) vertical line shaft, multistage
- WUC-LNG cryogenic (VS6) double case, multistage

See Bulletin PS-40-9

APKD
Vertical, Double Case,
Double Suction



Standards

- Flowserve

Operating Parameters

- Flows to 4600 m³/h (20 200 gpm)
- Heads to 500 m (1640 ft)
- Pressures to 50 bar (725 psi)
- Temperatures from -45°C (-50°F) to 95°C (200°F)
- Speeds to 1800 rpm

Features

- Double suction first stage impeller
- Double case construction
- Impellers keyed with lock collars
- Twin-volute casing
- Heavy-duty discharge head
- Open lineshaft construction
- Flanged column assembly with bearing retainers
- Large shaft with keyed lineshaft couplings
- Mechanically sealed
- Rigid, adjustable flanged coupling
- Solid shaft motor with NEMA or IEC thrust bearing
- Optional suction can drain

Related Configurations

- APKC single suction design

**Pleuger SUBM
Deep-Well Submersible
(Water-Filled Design)**



Standards

- Flowserve
- CSA, WIMES 3.03, EMV, KTV, CE, VDE and other certifications

Operating Parameters

- Flows to 4500 m³/h (19 800 gpm)
- Heads to 800 m (2625 ft)
- Motor sizes to 5000 kW (6700 hp)
- Speeds from 200 to 3600 rpm

Features

- Wet type motors with watertight insulated windings
- Dynamically balanced impellers
- Prefilled motors with food grade additives
- Heavy-duty, adjustable, self-aligning thrust bearings
- Friction welded shafts
- Non-toxic Class Y winding insulation for potable water services
- Variable frequency drive and high-temperature options
- Choice of materials
 - Cast iron
 - Bronze
 - Austenitic stainless steels
 - Duplex stainless steels
 - Reinforced composite

Related Configurations

- Byron Jackson SUBM deep-well submersible (oil-filled design)

See Bulletin PS-50-3

**Byron Jackson SUBM
Deep-Well Submersible
(Oil-Filled Design)**

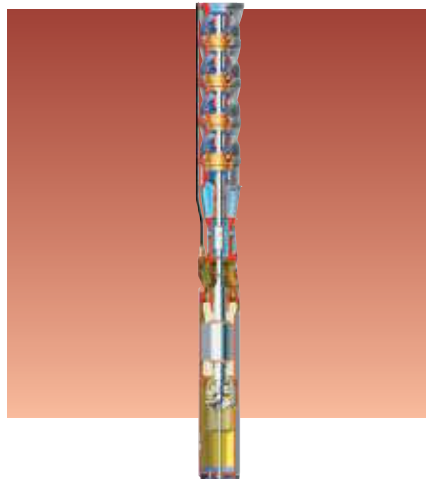

Standards

- Flowserve
- NSF Standard 61 Certification
- Certification program accredited by RvA, Dutch Council for Accreditation

Operating Parameters

- Flows to 4500 m³/h (19 800 gpm)
- Heads to 800 m (2625 ft)
- Motor sizes to 1500 kW (2000 hp)
- Speeds from 1000 to 3600 rpm

Features

- Oil-filled motors with self-contained force feed, filtered, cooled oil circulation system
- Vacuum pressure impregnated (VPI) epoxy, class F insulation system
- Double-acting thrust bearing system
- Dynamically balanced, heavy-duty, high-efficiency impellers
- Variable frequency drive and high-temperature options
- Choice of materials
 - Cast iron
 - Bronze
 - Austenitic stainless steels
 - Duplex stainless steels
 - Reinforced composite
- Choice of seals
 - Mercury seal
 - Double mechanical seal
 - Single, pressurized mechanical seal

Related Configurations

- Pleuger SUBM deep-well submersible (water-filled design)

See Bulletin PS-50-3

**MSX
Solids Handling,
Submersible**

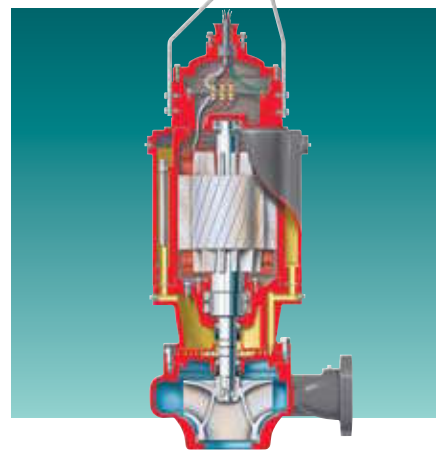

Standards

- Flowserve

Operating Parameters

- Flows to 4545 m³/h (20 000 gpm)
- Heads to 90 m (300 ft)
- Temperatures to 40°C (104°F)
- Discharge sizes from 80 mm (3 in) to 500 mm (20 in)
- Motor to 224 kW (300 hp)
- Solids handling to 80 mm (3 in) diameter spherical

Features

- High-efficiency hydraulics
- EPACT rated motor
- Spike-resistant windings
- Class H rated insulation system
- Dynamically balanced shaft and rotor
- Mounting options
 - Wet pit
 - Dry pit
 - Transportable

Available Configurations

- MSX Series 1: Sizes from 75 mm (3 in) to 150 mm (6 in)
- MSX Series 2/3: Sizes to 500 mm (20 in)

See Bulletin PS-50-2

MVX
Solids Handling, Wet Pit

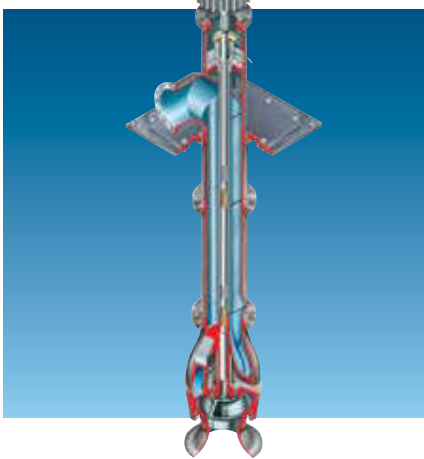

Standards

- Flowserve

Operating Parameters

- Flows to 17 000 m³/h (75 000 gpm)
- Heads to 40 m (130 ft)
- Sizes 250 mm (10 in) to 1200 mm (48 in)
- Drivers to 950 kW (1250 hp)
- Solids up to 150 mm (6 in)

Features

- Heavy-duty fabricated discharge head designed with fabricated flange and splitter vane
- Symmetrical bowl with multi-volute design
- Hydraulically balanced design
- Enclosed non-clog impeller
- Enclosed lineshaft
- Splitter vane in the column and discharge head
- Mechanical seal or soft packing shaft sealing options
- Hollow or solid shaft motor style
- 416 stainless steel lineshafts
- Separate steel soleplate
- Bronze lineshaft bearings
- Suction bell
- Standard suction bell wear rings
- Optional impeller wear rings

See Bulletin PS-40-5

MFV
Solids Handling

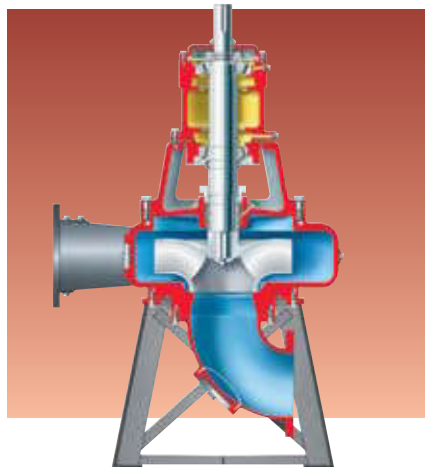

Standards

- Flowserve

Operating Parameters

- Flows to 2275 m³/h (10 000 gpm)
- Heads to 90 m (300 ft)
- Sizes to 400 mm (16 in)

Features

- Variety of nozzle position options
- Direct or independent motor mounting
- Minimal shaft deflection
- Oversized shaft and reduced overhang
- Hardened chrome steel wear rings
- Seal chamber accommodates packing or mechanical seals
- Adjustable impeller clearance
- Shaft sleeve options
 - 316 stainless steel
 - Hardened chrome steel
- Bearing housing features
 - Ball or tapered roller bearings
 - Integral jacking bolts for wear ring adjustment
 - Accessible lubrication points

Available Configurations

- MF horizontal, end suction
- MFV vertical with motor on separate floor (shown)
- MFC vertical with direct connected motor

See Bulletin PS-10-3

MNV
Large Capacity, Solids Handling

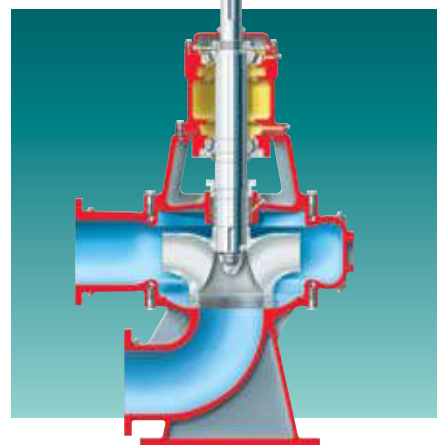

Standards

- Flowserve

Operating Parameters

- Flows to 45 500 m³/h (200 000 gpm)
- Heads to 90 m (300 ft)
- Sizes to 1800 mm (72 in)

Features

- Variety of nozzle position options
- Direct or independent motor mounting
- Minimal shaft deflection
- Oversized shaft and reduced overhang
- Hardened chrome steel wear rings
- Seal chamber accommodates packing or mechanical seals
- Adjustable wear ring clearance
- Shaft sleeve options
 - 316 stainless steel
 - Hardened chrome steel
- Bearing housing features
 - Tapered roller bearings
 - Integral jacking bolts for wear ring adjustment
 - Accessible lubrication points

Available Configurations

- MN horizontal, end suction
- MNF vertical, bottom suction, direct connected motor
- MNZ vertical, bottom suction, motor on separate floor
- MNC vertical with base elbow, direct connected motor
- MNV vertical with base elbow, motor on separate floor (shown)

See Bulletin PS-10-4

FRBHJC Cantilever Sump

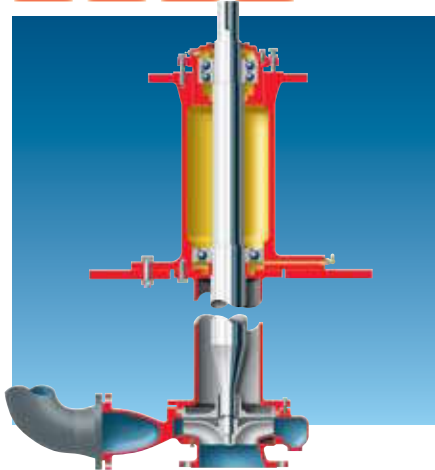

Standards

- Flowserve

Operating Parameters

- Flows to 2700 m³/h (12 000 gpm)
- Heads to 100 m (330 ft)
- Temperatures to 150°C (300°F)
- Speeds to 1780 rpm

Features

- True stiff shaft cantilever design, without bottom bearing or flushing water
- Steep head capacity
- Semi-open, full vane impeller with back pump-out vanes
- Direct coupled or V-belt driven
- Extra heavy-duty alloy steel shaft

Related Configurations

- FRBH heavy-duty paper stock and process
- FRBHJ vertical lineshaft sump

See Bulletin PS-10-16

MJ and MJC Hard Metal, Slurry Sump



Standards

- Flowserve

Operating Parameters

- Flows to 225 m³/h (1000 gpm)
- Heads to 30 m (100 ft)
- Pressures to 10 bar (150 psi)
- Temperatures to 110°C (225°F)
- Solids from 2% to 70% by weight
- Speeds to 1780 rpm

Features

- Abrasion- and corrosion-resistant high chrome iron concentric casing
- Integrally cast straightening vanes in the suction nozzle
- Closed impeller with pump-out vanes on front and rear shrouds
- MJ has fluted cutlass rubber bearings
- MJC has restriction bushing
- Directly coupled or V-belt driven
- Options
 - Hard metal expeller
 - Open and recessed impellers
 - Choice of materials

Available Configurations

- MJ submerged bearing and lineshaft design
- MJC cantilever design
- M horizontal, hard metal abrasive slurry

See Bulletin PS-10-19

RJ and RJC Rubber Lined, Slurry Sump

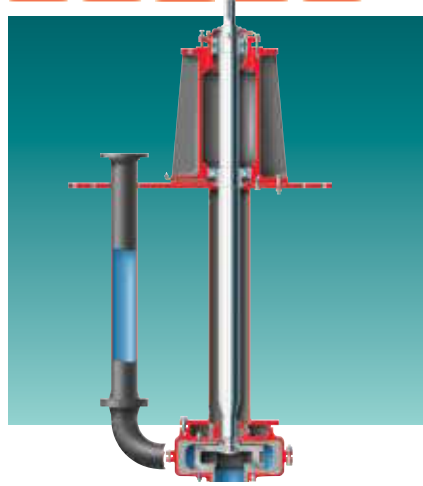

Standards

- Flowserve

Operating Parameters

- Flows to 225 m³/h (1000 gpm)
- Heads to 30 m (100 ft)
- Pressures to 10 bar (150 psi)
- Temperatures to 110°C (225°F), depending on material
- Solids from 2% to 70% by weight
- Speeds to 1780 rpm

Features

- Radially split casing with anti-prerotator vanes in suction nozzle
- Casing liners pressure molded on steel backing plates; multiple materials available
- Pressure molded rubber closed impeller with pump-out vanes on front and rear shrouds
- RJ has fluted cutlass rubber bearings
- RJC has restriction bushing
- Directly coupled or V-belt driven
- Options
 - Hard metal expeller
 - Choice of liner materials

Available Configurations

- RJ submerged bearing and lineshaft design
- RJC cantilever design
- R horizontally split, rubber lined slurry

See Bulletin PS-10-18

Terra-Titan Cantilever Sump



Standards

- Flowserve

Operating Parameters

- Flows to 250 m³/h (1100 gpm)
- Heads to 45 m (150 ft)
- Pressures to 5 bar (70 psi)
- Temperatures to 100°C (212°F)
- Sizes from 40 mm (1.5 in) to 125 mm (5.0 in)
- Sump depths from 700 mm (28 in) to 1800 mm (72 in)

Features

- One-piece suspended, oversized cantilever shaft construction
- Interchangeable urethane or hard metal wetted parts
- Concentric casing design
- Double suction, hydraulically balanced open impeller
- External impeller adjustment
- Renewable Terraprene urethane shaft sleeve
- Greased for life, heavy-duty, self-aligning roller bearings
- Upper and lower strainers
- Run-dry capability
- ANSI and ISO configurations
- Portable
- Lifting lugs
- Rigid motor mount pivot bar
- Available bottom suction tailpipe
- Multiple drive options

See Bulletin PS-10-7

MSX Solids Handling, Submersible

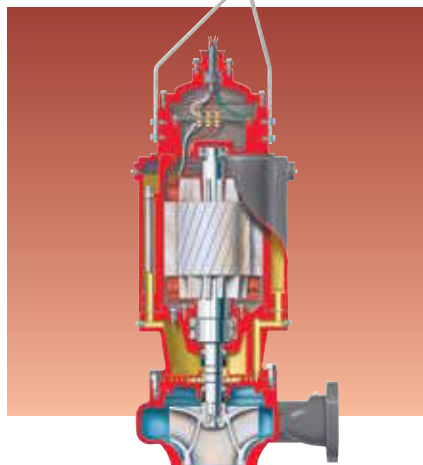

Standards

- Flowserve

Operating Parameters

- Flows to 4545 m³/h (20 000 gpm)
- Heads to 90 m (300 ft)
- Temperatures to 40°C (104°F)
- Discharge sizes from 80 mm (3 in) to 500 mm (20 in)
- Motor to 224 kW (300 hp)
- Solids handling to 80 mm (3 in) diameter spherical

Features

- High-efficiency hydraulics
- EPACT rated motor
- Spike-resistant windings
- Class H rated insulation system
- Dynamically balanced shaft and rotor
- Mounting options
 - Wet pit
 - Dry pit
 - Transportable

Available Configurations

- MSX Series 1: Sizes from 75 mm (3 in) to 150 mm (6 in)
- MSX Series 2/3: Sizes to 500 mm (20 in)

See Bulletin PS-50-2

Drain-Titan Urethane Lined, Double Suction Sump

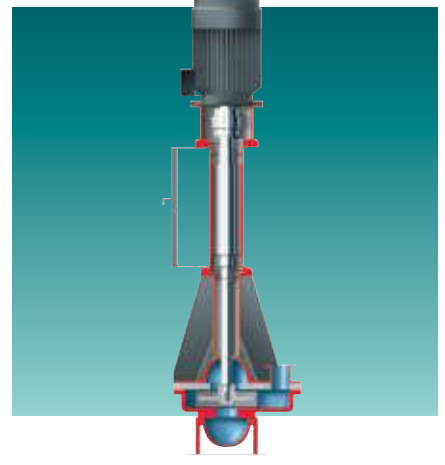

Standards

- Flowserve

Operating Parameters

- Flows to 160 m³/h (700 gpm)
- Heads to 40 m (130 ft)
- Pressures to 4 bar (55 psi)
- Sizes from 40 mm (1.5 in) to 100 mm (4 in)
- Solids to 15 mm (0.5 in)

Features

- Double suction, urethane coated wet-end
- Robust, integral unit construction
- Large diameter, stiff cantilever drive shaft
- No submerged bearings or seals
- Double-sided impeller with pre-set clearance
- Keyed and bored shaft coupling
- Standard single lip oil seal
- Urethane lined, slotted outlet pipe flange
- Grease lubricated, single row, deep groove ball bearings
- No priming required
- Run-dry capability

See Bulletin PS-10-7

CPXV Chemical Sump



Standards

- ISO 13709/API 610, 8th & 10th ed.
- ISO 5199

Operating Parameters

- Flows to 1400 m³/h (6160 gpm)
- Heads to 250 m (820 ft)
- Pressures to 25 bar (365 psi)
- Temperatures from -40°C (-40°F) to 350°C (660°F)

Features

- Heavy-duty casing with multi-ribbed discharge flange
- High-efficiency, semi-open impeller
- Column lengths to 10 m (32 ft)
- Heavy-duty thrust bearings with axial adjustment above soleplate level
- Accepts multiple seal arrangements
- Elastomeric split element coupling
- Options
 - Recessed impeller
 - Suction strainer
 - Spacer coupling
 - Rectangular or circular soleplate
 - Oil lubrication to thrust bearing
 - Zone Ø hazardous area beneath soleplate configuration
- CE marked and compliant with applicable European directives such as ATEX; available with GOST certification

Other Configurations

- CPXVR recessed impeller, chemical sump
- Fully jacketed, molten salt design

See Bulletin PS-10-30

ESP3 Chemical Sump

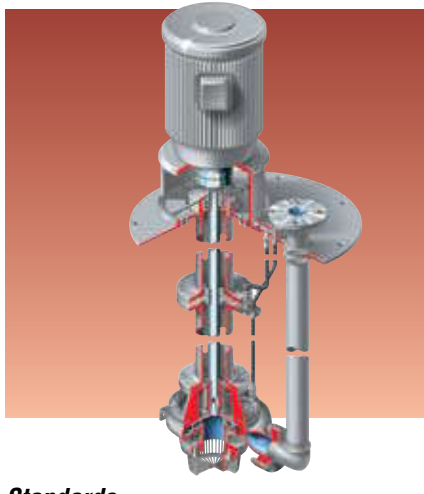

Standards

- Flowserve

Operating Parameters

- Flows to 1365 m³/h (6000 gpm)
- Heads to 90 m (300 ft)
- Pressures to 12 bar (175 psi)
- Temperatures to 180°C (350°F)

Features

- Optimized lineshaft bearing design to ISO 13709/API 610 spacing requirements
- Double row external thrust bearings
- Single and duplex configurations
- Flanged discharge
- Large basket strainer
- Industry standard TCV motors
- Lubrication options
 - Product lube for clear liquids
 - Dual particle separator for light solids
 - Grease lubrication
- Mounting plate sealing options
 - Vapor tight
 - Vapor proof
 - Pressurized design
- Options
 - Upper stuffing box
 - Sealing ring
 - Suction tailpipes
 - Level controls

Related Configurations

- ESP3 Lo-Flo
- ESP3 recessed impeller
- ESP3 high chrome iron

See Bulletin PS-10-24

PolyChem VGRP Engineered Polymer Composite Sump

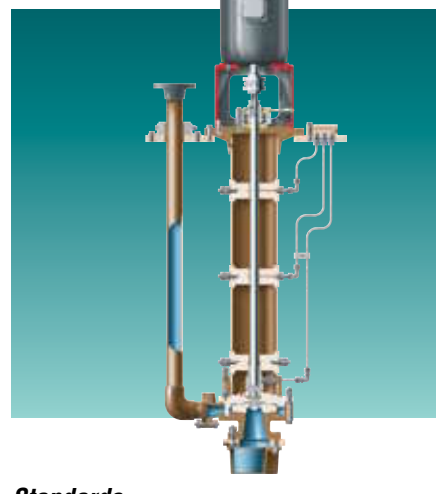

Standards

- Flowserve

Operating Parameters

- Flows to 565 m³/h (2500 gpm)
- Heads to 110 m (350 ft)
- Pressures to 17 bar (250 psi)
- Temperatures from -30°C (-20°F) to 90°C (200°F)

Features

- Glass reinforced vinyl ester
- Unitized casing with integrally molded, fully gusseted suction and discharge flanges
- Externally adjustable, semi-open impeller
- Shaft and bearing system operates well below the first critical speed
- Self-lubricated or external flush bearings
- Single-piece, lightweight, filament-wound, reinforced fiberglass composite column
- Single and duplex configurations
- Full basket strainer
- NEMA in-line motor
- Fiberglass mounting plate
- Tapered polygon impeller drive
- Pullout bearing retainers
- Level controls
- Choice of shaft metallurgy

Related Configurations

- PolyChem GRP engineered polymer composite

See Bulletin PS-10-17

Drain-Titan Urethane Lined, Double Suction Sump

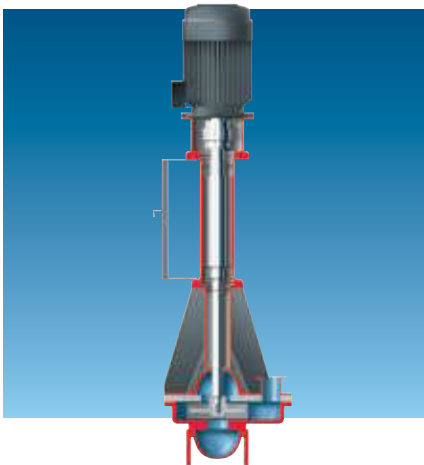

Standards

- Flowserve

Operating Parameters

- Flows to 160 m³/h (700 gpm)
- Heads to 40 m (130 ft)
- Pressures to 4 bar (55 psi)
- Sizes from 40 mm (1.5 in) to 100 mm (4 in)
- Solids to 15 mm (0.5 in)

Features

- Double suction, urethane coated wet-end
- Robust, integral unit construction
- Large diameter, stiff cantilever drive shaft
- No submerged bearings or seals
- Double-sided impeller with pre-set clearance
- Keyed and bored shaft coupling
- Standard single lip oil seal
- Urethane lined, slotted outlet pipe flange
- Grease lubricated, single row, deep groove ball bearings
- No priming required
- Run-dry capability

See Bulletin PS-10-7

VSMP Vertical Standard Motor



Standards

- Flowserve

Operating Parameters

- Flows to 135 m³/h (600 gpm)
- Heads to 70 m (220 ft)
- Pressures to 12 bar (175 psi)
- Temperatures from -40°C (-40°F) to 120°C (250°F)

Features

- Glass reinforced polymer, high-efficiency, semi-open or closed impellers standard
- Industry standard NEMA motors
- Stainless steel, self-aligned mechanical seal
- Back pullout design
- Clamp-type mounting plate
- Options
 - Cast iron, bronze or 316 stainless steel impellers
 - Stub shaft design

Related Configurations

- SMP standard motor pump
- SMX non-metallic standard motor pump

See Bulletin PS-10-26

ECPJ (VS4) Sump

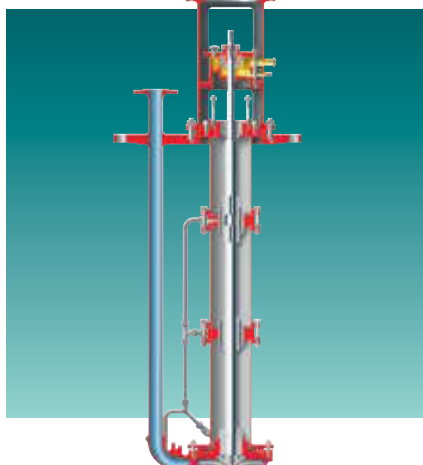

Standards

- ISO 13709/API 610 (VS4), latest ed.

Operating Parameters

- Flows to 1000 m³/h (4400 gpm)
- Heads to 150 m (500 ft)
- Pressures to 20 bar (285 psi)
- Temperatures to 350°C (660°F)
- 45 sizes available

Features

- Lineshaft configuration
- Four impeller designs
 - Closed multivane impeller with front wear rings and back vanes
 - Closed multivane impeller with front and rear wear rings
 - Open multivane impeller with back vanes
 - Free flow impeller with back vanes
- Multiple shaft sealing options
 - V-ring
 - Throttle bushing
 - Lip seal with grease-filled stuffing box
 - Soft packing
- ISO 21049/API 682 seal chamber accommodates multiple seal types
- Column lengths to 6 m (22 ft); suction pipe available
- Choice of ISO/API materials
- NACE MR0175 materials available
- Internal or external bearing flushing
- Bearing cooling
- Suction strainer

See Bulletin PS-10-10

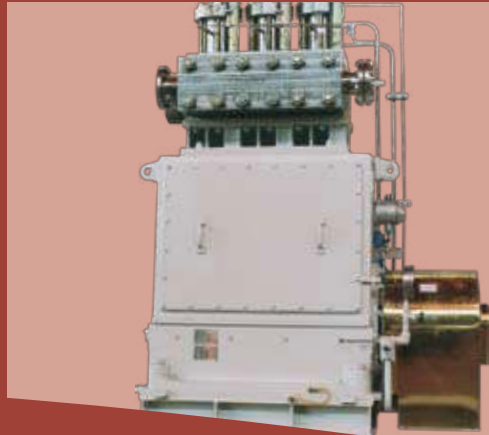



Positive Displacement

Gear

<i>GR Series</i>	52
<i>GA Series</i>	52
<i>Gearex</i>	52

Screw

<i>TSP</i>	53
<i>MP1</i>	53
<i>MP1 Systems Packaging</i>	53

Reciprocating

<i>YHT</i>	54
<i>HS</i>	54
<i>VTE</i>	54
<i>VQE</i>	54
<i>V</i>	54
<i>VSE</i>	54

GR Series Double Helical, Gear

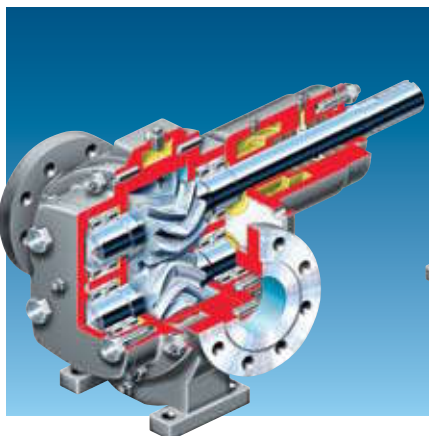

Standards

- Flowsolve

Operating Parameters

- Flows to 275 m³/h (1200 gpm)
- Pressures to 35 bar (500 psi)
- Temperatures to 350°C (650°F)
- Speeds to 1800 rpm
- Viscosities to 1 million ssu

Features

- Double helical, herringbone gears
- Quiet, pulse-free flow
- High speed pump capability
- Between bearings design
- Hydraulically balanced design
- Stuffing box accommodates packing or mechanical seals
- High-capacity, double row roller bearing
- Self-priming
- Run dry capability
- Low NPSHr
- Back pullout design
- Options
 - Mechanical seal
 - Direct V-belt drive
 - Extra deep jacketed stuffing box
 - Jacketed body
 - Babbitted carbon sleeve bushing
 - INSUROCK® wearplates
 - Integral safety relief valve

Available Configurations

- GR standard gear width
- GRW wide gears for high flows
- GRH narrow gears for high pressures

See Bulletin PS-60-3

GA Series Cast Iron, Double Helical, Gear

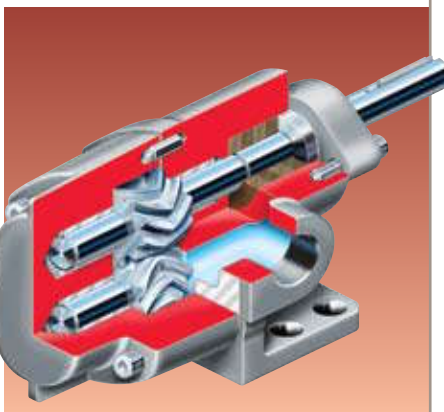

Standards

- Flowsolve

Operating Parameters

- Flows to 27 m³/h (120 gpm)
- Pressures to 17 bar (250 psi)
- Temperatures to 175°C (350°F)
- Speeds to 1800 rpm
- Viscosities to 50 000 ssu

Features

- Double helical, herringbone gears
- Quiet, pulse-free flow
- High speed pump capability - off-the-shelf motors
- Between bearings design
- Self-lubricated babbitted carbon sleeve bearings standard; bronze bearings optional
- Hydraulically balanced design – no thrust bearings needed
- Convertible stuffing box accommodates packing or mechanical seals
- Threaded ports
- Back pullout design
- Available integral safety relief valve
- Multiple mounting configurations

Related Configurations

- GAS foot mounting (standard)
- GAF flange mounting
- GAC close coupled
- GSX series stainless steel, double helical, rotary gear pumps

Gearx Double Helical, Timed Gear

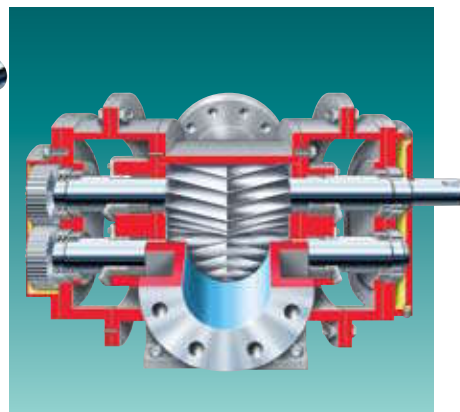

Standards

- Flowsolve

Operating Parameters

- Flows to 180 m³/h (800 gpm)
- Pressures to 20 bar (300 psi)
- Temperatures from -50°C (-60°F) to 450°C (850°F)
- Viscosities to 1 million ssu

Features

- Double helical, herringbone gears
- Quiet, pulse-free flow
- External timing gears
- Between bearings design
- Heavy-duty, double row roller bearings
- Direct coupled
- Options
 - Water cooled bearings
 - Steam or water jacketed bodies
 - Vertical mounting configuration
 - Mechanical seals
 - Lantern rings
 - Shaft slingers
 - Split bearing brackets
 - Flange mounting brackets
 - Jackshafts for V-belt drives

TSP Double Suction, Twin-Screw

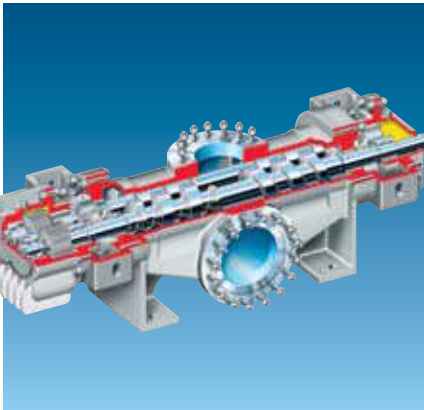

Standards

- API 676, latest ed.

Operating Parameters

- Flows to 2550 m³/h (11 200 gpm)
- Pressures to 100 bar (1450 psi)
- Temperatures to 450°C (850°F)
- Speeds to 1800 rpm
- Viscosities to 200 million ssu
- Slurry concentrations to 70% by weight

Features

- Positive displacement timed two-screw
- Double suction design
- Split bearing bracket for ease of maintenance
- Versatile ISO 21049/API 682 compliant stuffing box design
- Integral or pinned screw elements
- Spur-tooth timing gears
- Chrome-plated pump bores
- Options
 - Fully external bearings and timing gears
 - Internal bearings and timing gears
 - Temperature control packages
 - Hopper-top construction
 - Vertical barge configuration
 - Choice of materials
 - Multiple hard coatings for bores and screws

See Bulletin PS-60-1

MP1 Multiphase Twin-Screw

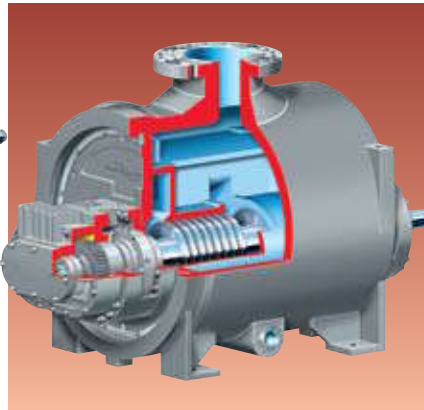

Standards

- API 676, latest ed.

Operating Parameters

- Flows to 1990 m³/h (8750 gpm)
- Pressures to 50 bar (720 psi)
- Temperatures to 450°C (850°F)
- Speeds to 2000 rpm
- Viscosities to 8000 cp
- Multiphase pumping to 100% GVF (gas void fractions)

Features

- Non-contacting design with one-piece pump shafts
- Three pumping locks for low pulsation flow
- Through-bolt bearing bracket design
- ISO 21049/API 682 seal chamber with split brackets accommodates single and double cartridge seals
- Double suction design with low NPSH capability
- AGMA 11 helical timing gears
- Chrome plated bores and hard coated screws
- Options
 - Multiple hard coatings for bores and screws
 - Choice of materials, including NACE
 - Customized pitch
 - Customized packaging
 - Variable speed drive
 - Natural gas or diesel engine drive

Other Configurations

- High pressure: 100 bar (1450 psi)

See Bulletin PS-60-2

MP1 Systems Packaging



Standards

- Flowserve
- ASME

Features

- Standard or custom engineered system packaging available
- Driver options
 - Electric motor
 - Electric motor with variable speed drive (VSD)
 - Diesel or natural gas engine
- Complete piping systems
 - Suction, discharge, bypass and recycle piping
 - Block valves, control valves and check valves
 - Filters and strainers
 - Pressure, temperature and flow instrumentation
- Complete, integrated control systems
 - PLC based
 - Controls for pump, valves, instrumentation and alarms, VSD, etc.
 - Motor control center
- Single and multiple skid options for integration of controls, pump and piping
- Special enclosures for arctic-like conditions or other harsh environments

YHT and HS Horizontal Reciprocating

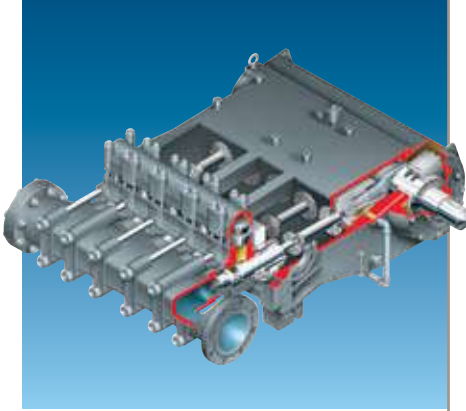

Standards

- API 674, latest ed.
- ASME section III

Operating Parameters

- 75 mm (3 in) to 250 mm (10 in) stroke
- Flows to 775 m³/h (3400 gpm)
- Standard pressures to 555 bar (8030 psi); custom pressures to 2070 bar (30 000 psi)
- Temperatures from -40°C (-40°F) to 350°C (650°F)
- Power to 2560 kW (3430 hp)
- Speeds to 530 rpm

Features

- Self-aligning plungers
- Sectionalized fluid end components
- Fully enclosed power end with generous oil reservoir
- Independent crosshead extension rod
- Integrally cast and precision machined cylindrical crosshead guides
- Triple lip seal at crosshead extensions
- Fully reversible crankshaft for V-belt drive or direct coupling
- Stuffing box assemblies individually bolted to fluid cylinder
- Splash-type or full pressure lubrication system
- Threaded primary drain
- Options
 - Overhead motor mounting
 - Spring loaded stuffing box
 - Discharge pulsation dampeners

See Bulletin PS-70-1

VTE, VQE, V and VSE Vertical Reciprocating

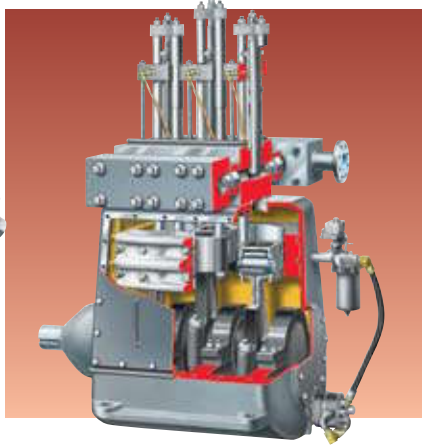

Standards

- API 674, latest ed.
- ASME section III

Operating Parameters

- 140 mm (5.5 in) to 225 mm (9 in) stroke
- Flows to 1140 m³/h (5000 gpm)
- Standard pressures to 619 bar (8975 psi); custom pressures to 2070 bar (30 000 psi)
- Temperatures from -40°C (-40°F) to 350°C (650°F)
- Power to 3450 kW (4625 hp)
- Speeds to 360 rpm

Features

- Outboard packed inverted design
- Easily accessible stuffing box
- Integrated suction and discharge manifold
- Complete separation of liquid end from power end
- Valve design suitable for conditions of service
- Spherical feature for plunger alignment
- Power-end maintenance inspection covers
- Forced feed lubrication
- Options
 - Spring loaded packing
 - Pulsation dampeners
 - Sectionalized fluid ends

See Bulletin PS-70-1



Specialty Products

Nuclear Pumps and Seals

DFSS	58
DVSS	58
N-Seals	58
WDF	58
DVSR	59
CN	59
HDR	59
CA	60
CAM	60
CAV	60
EG	61
MEV	61

Extreme Temperature

WUC-LNG Cryogenic	62
VKW Cryogenic	62
TKW Cryogenic	62
Byron Jackson	62
SUBM Geothermal	

Others

Hydraulic Decoking Systems	63
Pleuger WFSD	63
Azimuthing Thruster	
DWEER™	64
ERT	64
CVP	64
Barge Pump	65
Molten Salt VTP	65



DFSS and DVSS Nuclear Radially Split, Single Stage

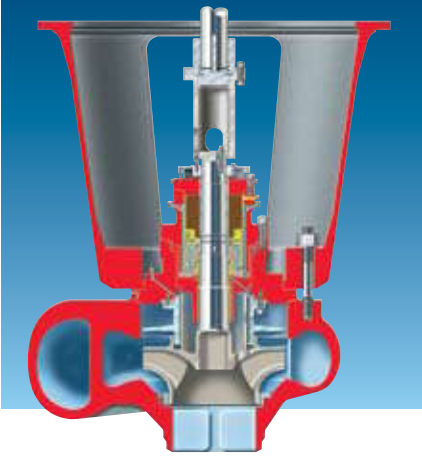

Standards

- ASME Section III, Class 1

Operating Parameters

- Flows to 24 500 m³/h (108 000 gpm)
- Heads to 250 m (820 ft)
- Pressures to 170 bar (2500 psi)
- Temperatures to 300°C (580°F)
- Speeds to 1800 rpm
- Power rating to 9400 kW (12 600 hp)

Services

- Primary coolant
- Reactor recirculation
- Primary heat transport

Features

- Fourth generation design
- One-piece cast pump casing
- Double volute design case for BWR and PHWR
- Diffuser with torus-type design casing for PWR
- Upgraded rotating element
 - One-piece welded shaft-impeller-journal assembly
 - Fully machined and balanced as single rotating unit
- Hydrostatic-pressurized radial bearing
 - Operates submerged in radioactive system water at loop temperature of approximately 300°C (580°F)

See Bulletin FPD-2

N-Seals Nuclear Mechanical Seals

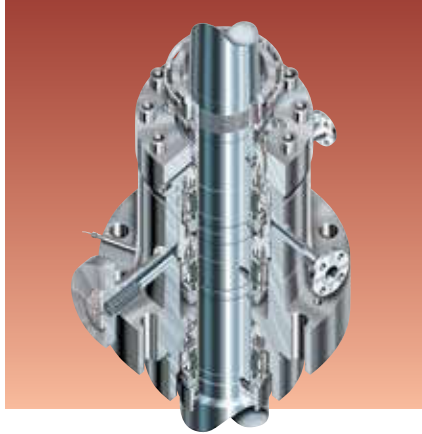

Standards

- ASME Section III, Class 1

Operating Parameters

- Pressures to 150 bar (2175 psi)
- Temperatures to 80°C (180°F)
- Speeds to 1800 rpm

Services

- Primary coolant
- Reactor recirculation
- Primary heat transport

Features

- Controlled leakage seal
- Two to four stage configurations
- Provisions for monitoring pressure, temperature and flow at each stage
- Internal screens for trapping particles
- Each stage capable of handling full system pressure - redundancy
- Optional hydrodynamic features and dirt grooves
- Variety of seal face materials available
- All stages use the same components and are interchangeable
- Seal faces are supported by gaskets to minimize pressure points and deflection

See Bulletin PSS-80-2.2

WDF Nuclear Vertical, Single Stage

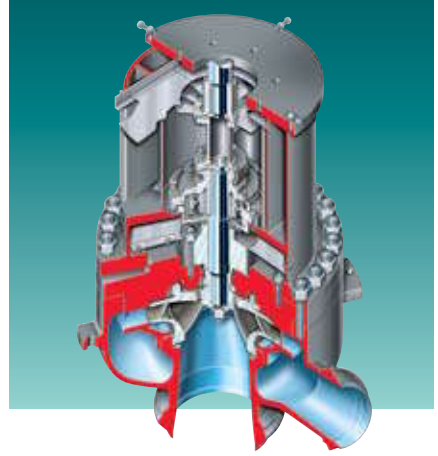

Standards

- ASME Section III, Class 2 and 3

Operating Parameters

- Flows to 900 m³/h (4000 gpm)
- Heads to 245 m (800 ft)

Services

- Containment spray
- Low pressure safety injection
- Residual heat removal

Features

- Vertical, single stage design
- Bottom suction, horizontal discharge
- Forged diffuser casing design
- Optimized hydraulic performance
- Unique spacer coupling design
- Mechanical seal replacement without motor or casing cover removal
- Upgraded rotor design
 - Radial bearing located between coupling and seal
 - Reduced shaft deflection
 - Improved pump and mechanical seal life and reliability
- Cartridge mechanical seal
- Reduced assembly time

See Bulletin FPD-2

DVSR Nuclear
Radially Split, Volute
Casing, Single Stage

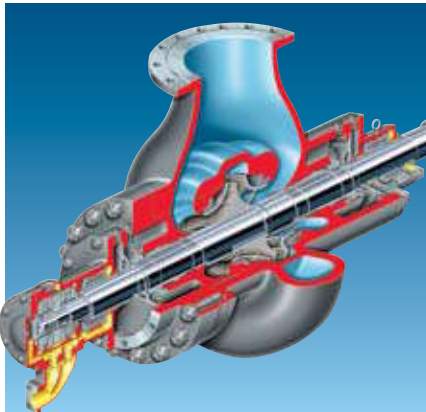

Standards

- ASME Section VIII

Operating Parameters

- Flows to 4535 m³/h (19 945 gpm)
- Heads to 800 m (2625 ft)
- Pressures to 100 bar (1470 psi)
- Temperatures to 210°C (410°F)
- Power to 8000 kW (10 700 hp)
- Speeds to 6000 rpm

Services

- Reactor and steam generator feedwater

Features

- Cast volute casing configuration
- Double cover design
- High speed pump design
- Double suction impeller
- Centerline mounted
- Pressure breakdown bushing or mechanical seal
- Sleeve radial and tilting pad thrust bearings standard

See Bulletin FPD-2

CN Nuclear
Radially Split, Diffuser
Casing, Single Stage

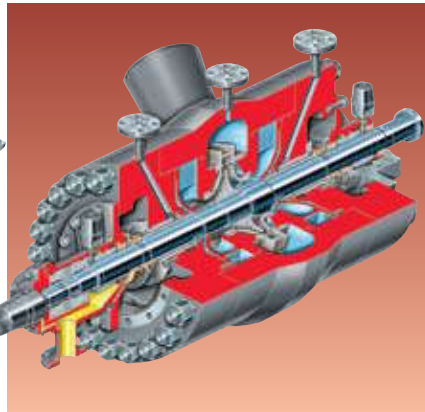

Standards

- ASME Section VIII

Operating Parameters

- Flows to 5065 m³/h (22 300 gpm)
- Heads to 800 m (2625 ft)
- Pressures to 100 bar (1470 psi)
- Temperatures to 210°C (410°F)
- Power to 11 200 kW (15 000 hp)
- Speeds to 6000 rpm

Services

- Reactor and steam generator feedwater

Features

- Diffuser casing configuration
- Forged barrel
- High-speed pump design
- Double suction impeller
- Special impeller designs for low NPSHa conditions
- Centerline mounted
- Pressure breakdown bushing or mechanical seal
- Sleeve radial and tilting pad thrust bearings standard

See Bulletin PS-80-2

HDR Nuclear
Radially Split, Volute
Casing, Single Stage

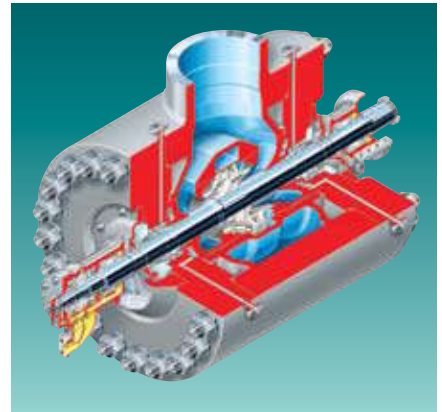

Standards

- ASME Section VIII

Operating Parameters

- Flows to 5065 m³/h (22 300 gpm)
- Heads to 800 m (2625 ft)
- Pressures to 100 bar (1470 psi)
- Temperatures to 210°C (410°F)
- Power to 11 200 kW (15 000 hp)
- Speeds to 6000 rpm

Services

- Reactor and steam generator feedwater

Features

- Volute casing configuration
- Forged barrel
- High-speed pump design
- Double suction impeller
- Special impeller designs for low NPSHa conditions
- Centerline mounted
- Pressure breakdown bushing or mechanical seal
- Sleeve radial and tilting pad thrust bearings standard

See Bulletin PS-80-2

**CA Nuclear
Diffuser Casing,
Multistage, Utility Barrel**

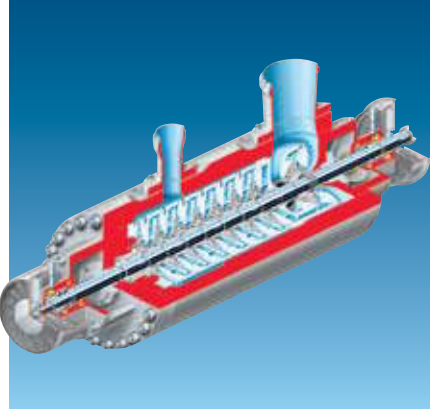

Standards

- ASME Section III, Class 2 and 3

Operating Parameters

- Flows to 5250 m³/h (23 000 gpm)
- Discharge pressures to 450 bar (6500 psi)
- Temperatures to 250°C (480°F)
- Speeds to 6000 rpm

Services

- Safety injection

Features

- Internal casing with segmented stage elements
- Diffuser-guide vane construction
- Precision cast in-line impellers
- Heavy-duty forged barrel with forged steel discharge cover
- Balance drum and sleeve, made from hardened stainless forgings
- Ball thrust and ball radial bearings
- Fan-cooled bearing housings
- Renewable casing rings and sleeves
- Ground forged steel shafting
- Cartridge seals

See Bulletin FPD-2

**CAM Nuclear
Diffuser Casing,
Multistage, Utility Barrel**

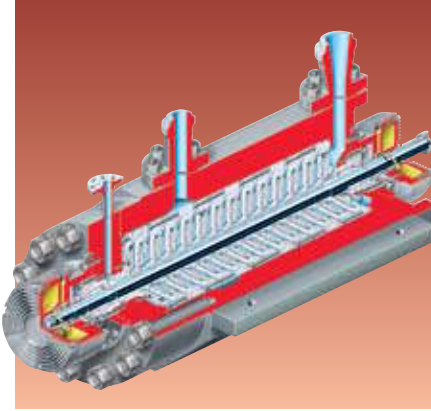

Standards

- ASME Section III, Class 2 and 3

Operating Parameters

- Flows to 45 m³/h (200 gpm)
- Heads to 1920 m (6300 ft)
- Pressures to 235 bar (3410 psi)
- Temperatures to 120°C (250°F)

Services

- CVCS charge
- Control rod drive

Features

- Multistage, double case design
- Unique, compact design patented modular impellers
 - Low-flow stability and reliability over a wide range of flows
 - No surging or pulsations
- Ball-ball construction
- Dry disk spacer coupling
- Flanged axial thrust-balancing device
- Modularized assembly and disassembly may be conducted without the use of a torch
- Forged barrel with no attachment welds
- Cartridge mechanical seals with no attachment welds
- No auxiliary cooling required

See Bulletin FPD-2

**CAV Nuclear
Vertical, Double Case,
Multistage**

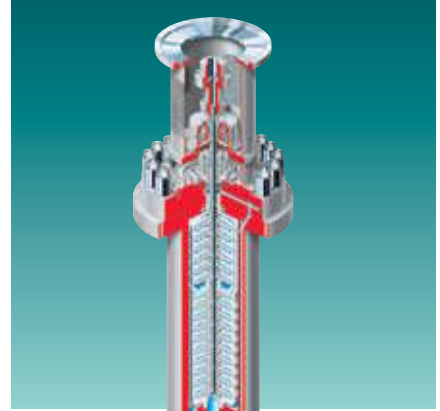

Standards

- ASME Section III, Class 2 and 3

Operating Parameters

- Flows to 60 m³/h (265 gpm)
- Heads to 2000 m (6560 ft)
- Pressures to 235 bar (3410 psi)
- Temperatures to 100°C (212°F)
- Speeds to 3600 rpm

Services

- CVCS charge

Features

- Multistage, double case design
- Barrel rated at full discharge pressure
- Suction and discharge connections at bottom of barrel
- Diffuser design with back-to-back impeller mounting to minimize thrust
- Cartridge mechanical seal
- Thrust bearings provided in either pump or motor as required
- Spacer coupling

See Bulletin FPD-2

**EG Nuclear
Radially Split, Double
Suction**

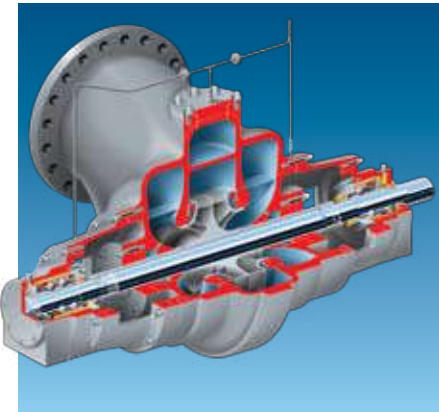

Standards

- ASME Section III, Class 3

Operating Parameters

- Flows to 4000 m³/h (17 610 gpm)
- Heads to 60 m (200 ft)
- Pressures to 14 bar (200 psi)
- Temperatures to 80°C (180°F)
- Power to 950 kW (1275 hp)
- Speeds to 3600 rpm

Services

- Component cooling water

Features

- Cast volute casing
- Double cover design
- Double suction impeller
- Centerline mounting
- Side suction and side discharge located above the mounting feet
- Cartridge mechanical seal
- 360° bearing housings
- Ball radial and ball thrust bearings

See Bulletin FPD-2

**MEV Nuclear
Vertical, Single Stage**

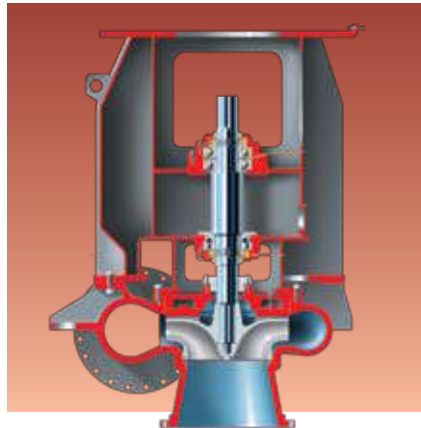

Standards

- ASME Section III, Class 3

Operating Parameters

- Flows to 5400 m³/h (23 760 gpm)
- Heads to 50 m (160 ft)
- Pressures to 14 bar (200 psi)
- Temperatures to 80°C (180°F)
- Speeds to 3600 rpm

Services

- Essential and non-essential service water

Features

- Cast casing and cover
- Bottom suction, horizontal discharge configuration
- Single stage, enclosed impeller
- Fabricated motor stand
- Cartridge mechanical seal
- Radial roller and double ball thrust bearings
- Grease lubricated bearings

See Bulletin FPD-2

WUC-LNG Cryogenic (VS6) Vertical, Double Case, Multistage

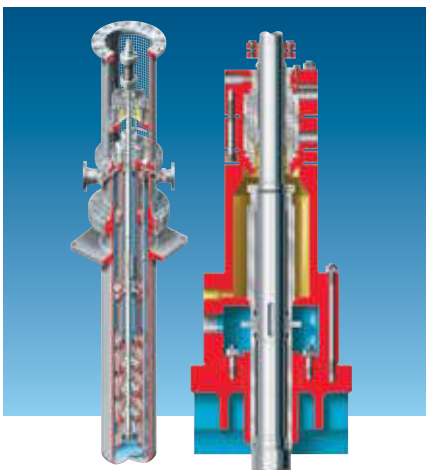

Standards

- API 610 (VS6), latest edition
- ASME Sections VIII and IX
- German Pressure Vessel Association (AD)
- British Standard BS 5500
- Compliance with Pressure Equipment Directive 97/23/EC

Operating Parameters

- Flows to 3000 m³/h (13 000 gpm)
- Heads to 1200 m (3900 ft)
- Pressures to 200 bar (3000 psi)
- Temperatures from -200°C (-325°F) to -45°C (-50°F)

Features

- Cofferdam system
- Radial or mixed flow hydraulics
- Low suction velocity can design
- Optional axial thrust tilting pad bearing configuration
- Stiff shaft design
- API 682 compliant mechanical seal chamber
- Flanged spacer type coupling
- Screen-type, non-sparking coupling guard
- Inside drain line
- Casing and impeller wear rings
- Reinforced motor stand
- Optional inducer

Related Configurations

- WUC (VS6) double case, multistage

See Bulletin PSS-40-9.1

VKW and TKW Cryogenic Liquid Expander (VS6) Double Case, Multistage, Electric Generator

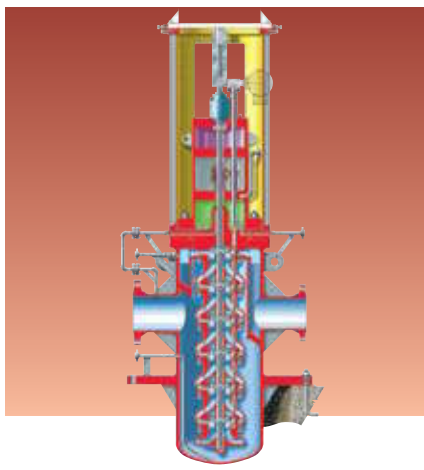

Standards

- API 610 (VS6), latest edition
- ASME Sections VIII and IX

Operating Parameters

- Expander flows to 2500 m³/h (11 000 gpm)
- Inlet pressures to 70 bar (1000 psi)
- Temperatures to -180°C (-290°F)
- Power to 3 MW (4000 hp)
- Runaway speed to 5400 rpm

Features

- Variable or fixed geometry
- Externally driven remote and local controlled variable wickets
- Optimal isentropic efficiency
- Overall improvement of compressor power efficiency
- Air-cooled generator
- Temperature reduction through liquid expansion
- Additional electric generation
- Low vibration
- Low noise level
- State-of-the-art gas seal
- Optimum specific speed selection

Available Configurations

- TKW variable geometry, double casing, multistage, electric generator
- VKW fixed geometry, double case, multistage, electric generator

See Bulletin PSS-90-7.1

Byron Jackson SUBM Geothermal Deep-Well Submersible



Standards

- IEC/VDE and other certifications

Operating Parameters

- Flows to 720 m³/h (3170 gpm)
- Heads to 800 m (2625 ft)
- Temperatures to 160°C (320°F)
- Motor sizes to 1500 kW (2000 hp)
- Speeds from 2900 to 3500 rpm
- Inner well diameters from 340 mm (13-3/8 in) to 508 mm (20 in)

Features

- Pump and motor design for geothermal application
- Oil filled motor with self-contained force feed, filtered, cooled oil circulation system
- Vacuum pressure impregnated (VPI) epoxy, Class F, insulation system
- Winding insulation system Class C 220°C (428°F)
- Double cable plug construction
- Double-acting thrust bearing system
- Dynamically balanced heavy-duty, high-efficiency impellers
- Optional variable frequency
- Choice of materials
- Double mechanical seal
- Motor design with breather diaphragm for pressure compensation
- Non-return design for high pressure
- Down hole monitoring system

Other Configurations

- Byron Jackson SUBM deep-well submersible (oil-filled design)

Hydraulic Decoking Systems

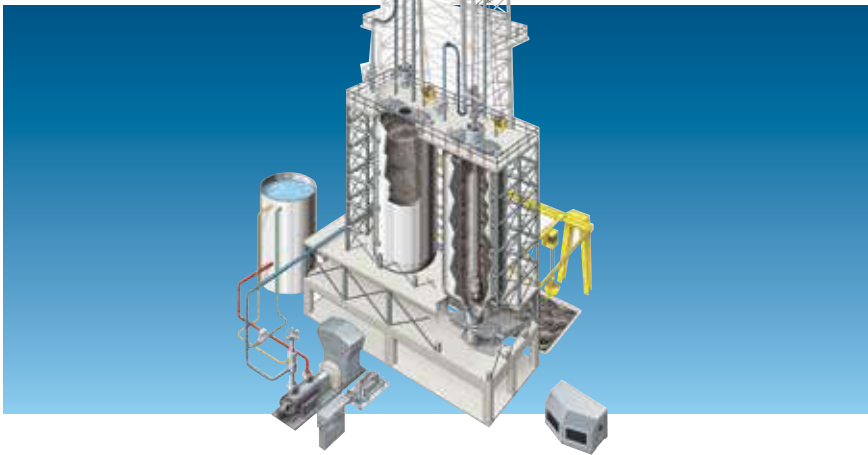

Flowserve Automated Hydraulic Decoking Systems

- Increase delayed coking unit (DCU) capacity and improve operator safety
- Installed in more than 95% of the world's DCUs
- Complete systems with virtually all equipment needed to operate and control the hydraulic decoking process
- Extensive aftermarket support including specialists to evaluate system performance, improve reliability, and recommend operational and safety best practices

Complete Coke Cutting Systems

- Jet pump train: ISO 13709/API 610 (BB5) jet pump, driver, lube oil skid and control system panel
- Coke cutting system: decoking control valve, AutoShift™ combination cutting tool, rotary joint, isolation and bleed valves, drill stem, tool guide and enclosure and high-pressure hose
- Cutting assembly lifting system: crosshead, free-fall arresters, winches and winch controls, pulley blocks, and latch mechanism to stow the crosshead
- Automation, controls and instrumentation

AutoShift Combination Cutting Tool

- Removes the operator from the cutting deck
- Mode shifting is accomplished automatically and remotely by water pressurization and depressurization

- Provides greater system automation and improved efficiency while improving operator safety, reducing cycle time and easing maintenance
- Mode shifting helps to free impeded tools from slumped beds

Advanced Cutting Control

- Complete systems and enclosures to monitor and control the operations
- Continuous feedback signals indicate equipment and drum status (i.e., position in drum, rotational speed, wore rope tension, etc.)
- Embedded intelligence to process data for monitoring and control; operator interface only required for sequence exception
- Video and acoustic equipment to monitor cutting deck operations and coke chute conditions
- Remote winch and rotary joint operation
- Remote sensing of cutting jet impingement on the coke drum
- Interlocking safety systems
- IPS APEX™ data monitoring, transmission and control systems

Online Assurance Programs

- Access to data aggregation tools via the Technology Advantage™ Portal
- Enable experts to monitor, diagnose and communicate operating solutions to increase unit uptime

See Bulletin PS-90-6

Pleuger WFSD Azimuthing Thruster

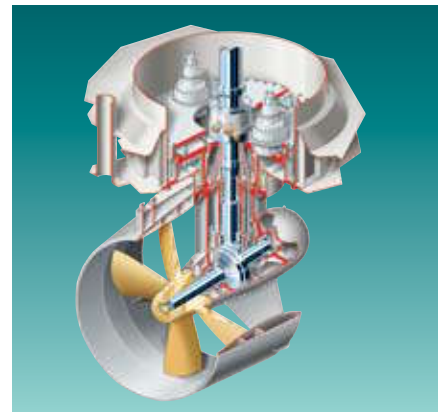

Standards

- Flowserve

Applications

- Semi-submersible drilling rigs
- Floating production, storage and offloading vessels
- Drill ships
- Crane vessels and pipelay vessels

Features

- Up to 5 m (16.5 ft) propeller diameter
- Up to 4500 kW (6000 hp) input
- 4- or 5-blade fixed pitch propeller
- 7° tilted propeller shaft
 - Propulsion and steering with thrust in any direction
 - Minimal thruster-hull and thruster-thruster interaction for higher net thruster output
 - Mounting and dismantling underwater without dry-docking
 - Customization to meet specific application needs
- Duplex thrust bearing allows windmilling at any speed
- Automatic pressure compensation system adapts differential pressure to draft
- Fully flooded gear housing provides optimum lubrication
- Easy underwater mounting; secured during installation by hydraulically operated locking mechanism
- Fully redundant closed-loop hydraulic steering system as standard

See Bulletin PSS-90-8.1

DWEER™
Dual Work Exchange
Energy Recovery



- Standards**
- Flowserve

- Operating Parameters**
- Brine flows to 350 m³/h (1.4 MGD); greater flows can be achieved by placing multiple DWEER units in parallel
 - Pressures to 75 bar (1090 ft)

- Features**
- Highest efficiency energy recovery device available
 - Noise levels below 83 dBa
 - Self adjustable to changing operating conditions
 - Super duplex stainless steel or fiber reinforced plastic pressure vessel
 - No leakage/lubrication required
 - Patented LinX™ valve regulates flow into vessels
 - Proven long-term reliability
 - Capable of passing solids/debris (no additional strainers required)
 - System responsibility with integrated controls
 - Slow operating speed
 - Smooth increase and decrease of system pressure during startup and shutdown

See Bulletin FPD-18

ERT
Energy Recovery Turbine



- Standards**
- Flowserve

- Operating Parameters**
- Brine flow to 1200 m³/h (5280 gpm)
 - Pressures up to 80 bar (2715 ft)
 - Efficiency up to 90%
 - Power to 1500 kW (2025 hp)
 - Special designs available on request

- Features**
- Especially designed for sea water reverse osmosis (SWRO) applications
 - Standardized product line
 - Wetted parts in super duplex stainless steel and non-metallics
 - Proven long-term reliability – over 25 years operating experience
 - Simple plant integration and control
 - Horizontal split casing
 - External standard bearings
 - Labyrinth double seals
 - Flat operating curve over typical RO performance range
 - No mixing, overflush or leakage

See Bulletin FPD-18

CVP
Vertical, Concrete Volute

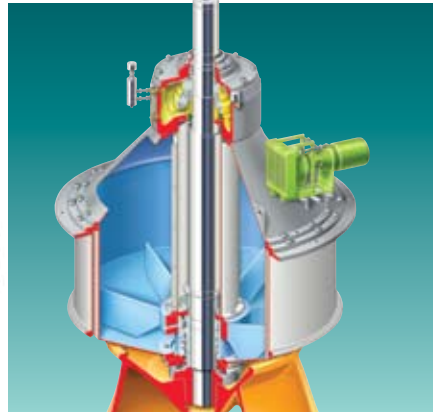

- Standards**
- Flowserve
 - Hydraulic Institute

- Operating Parameters**
- Flows to 115 000 m³/h (500 000 gpm)
 - Heads to 45 m (147 ft)

- Features**
- Vertical dry-pit design
 - Removable metallic pump pullout unit within a concrete volute
 - Suction bell connected to preformed high efficiency, vortex-free concrete suction box
 - Open mixed flow and closed mixed flow impeller options
 - Dry shaft design
 - No submerged bearings
 - Bearings and sealing systems easily accessible
 - Prefabricated concrete segments
 - Highly corrosion and erosion resistant
 - Liquidyne® or mechanical shaft seal
 - Inflatable static seal
 - Engineered to customer specifications

- Available Configurations**
- BSV open mixed flow impeller design
 - BCV closed mixed flow impeller design

See Bulletin PS-40-1

© Liquidyne is a registered trademark of IHC

Barge Pump

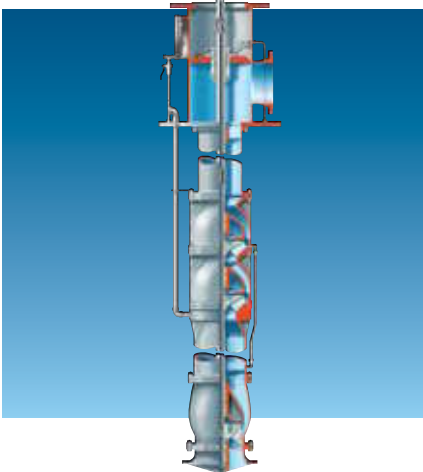

Standards

- Flowserve

Operating Parameters

- Flows to 1020 m³/h (4500 gpm)
- Heads to 185 m (600 ft)
- Pressures to 8.6 bar (125 psi)
- Temperatures from -30°C (-20°F) to 230°C (450°F)
- Discharge flanges to 250 mm (10 in)

Features

- Pollution prevention design
- Discharge head with access ports
- Rabbeted fit motor shaft to headshaft
- 1.5 m (5 ft) column pieces with integrally fabricated bearing support
- Automatic stuffing box bleed-off and valved drain line
- Special low NPSH priming stage impeller
- Semi-open series stage impeller
- Automatic air separation chamber with continuous seal

See Bulletin PSS-40-7.2

Molten Salt VTP

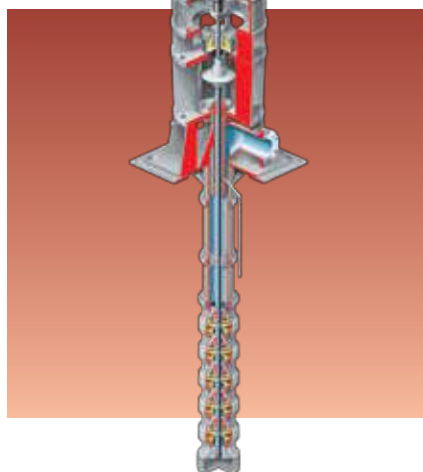

Standards

- Flowserve

Operating Parameters

- Flows to 13 600 m³/h (60 000 gpm)
- Heads to 530 m (1740 ft)
- Pressures to 100 bar (1450 psi)
- Temperatures to 600°C (1100°F)
- Settings to 20 m (65 ft)

Features

- Low pump submergence allows for greater energy generation
- Low NPSHr for enhanced suction performance
- Excellent heat dissipation prevents distortion at high temperatures
- Advanced fluid sealing system
- Materials engineered to equalize thermal growth and forestall distortion
- Wet pit or tank mounted
- Dynamically balanced enclosed impellers
- Flanged column pipe with open lineshaft construction
- Product lubricated bearings
- Cooling fan/disc
- Drain tubes
- Other options
 - Integral axial thrust bearing
 - Thrust balanced impeller
 - Coupling bellows
 - ISO 13709/API 610 construction

Related Configurations

- FRBHJC cantilever sump
- CPXV chemical sump

See Bulletin FPD-16

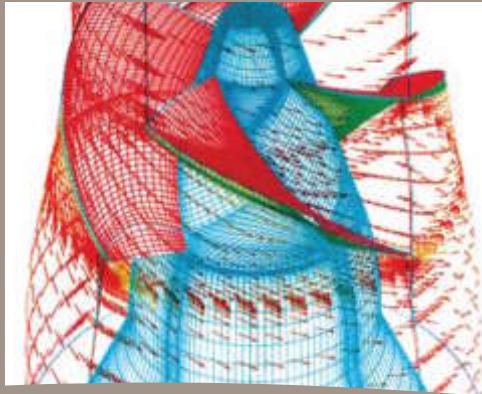

Additional Information

<i>Integrated Solutions Group</i>	68
<i>Other Flowserve Products</i>	70
<i>Reference Sources</i>	71





Flowserve Integrated Solutions Group

Reduce life cycle costs.

Manage assets more efficiently.

Increase plant uptime.

Enhance workforce skills.

Whether in a refinery, power plant or chemical complex, these ideas are taking hold as plant operators intensify their focus on maximizing plant profitability. Historically, applying these concepts to pumps and pumping systems has been achieved through reactive aftermarket programs. The Flowserve Integrated Solutions Group (ISG) is dedicated to helping customers proactively apply the principles of life cycle cost savings, asset optimization and equipment availability to pumps and pumping systems.



It's About the Bottom Line

Flowserve ISG helps customers take advantage of a focused set of aftermarket capabilities and technologies developed to derive greater value from their plant investments. Through the application of engineering know-how, industry-specific expertise, comprehensive training capabilities and advanced technologies, Flowserve helps customers focus on the issues that have the greatest potential to improve their bottom lines.

Flowserve ISG helps customers achieve:

- Plant output optimization through increased equipment availability
- Energy reductions at the plant, unit or equipment level
- Equipment optimization by increasing mean time between repair (MTBR) or by optimizing performance for actual system requirements
- Workforce skill set development for technical, maintenance and operations resources
- Environmental protection
- Safety and health protection
- Cost reductions through inventory and procurement optimization

No two situations are the same, so ISG tailors its solutions and programs to help each customer realize the full potential of its assets.



To help customers achieve maximum value from their investments, Flowserve ISG offers a comprehensive set of aftermarket services and programs.

Technical Services

A global team of more than 150 design and applications engineers is focused exclusively on helping customers maximize operational performance and plant profitability. With access to diagnostic technologies, testing facilities, mechanical and hydraulic engineering tools, and numerous support resources, this team performs exhaustive system assessments and implements solutions based on life cycle cost justifications.

- Technical assessments of pumps and systems for reliability and energy consumption
- Equipment upgrades, re-rates and retrofits
- Energy reduction and bad actor programs

Asset Management

Flowserve can help customers proactively manage their plant assets. Flowserve ISG offers various levels of asset management capability, from point-specific equipment monitoring to comprehensive management solutions with equipment records, drawings, real-time operational data and decision workflows.

Education and Training

Educational Services offers a wide range of programs that help plant operators, reliability engineers and maintenance personnel deepen their understanding of pumps and pumping systems.

- Maximize plant asset availability and reliability
- Increase mean time between repair (MTBR)
- Improve proficiency in the installation, maintenance and repair of pumping equipment and systems

Business Consulting

Flowserve ISG Business Consultants help customers identify savings opportunities associated with business and operational processes. Typical engagements focus on procurement efficiency, inventory optimization and high-level performance analyses and compare business performance metrics to established industry benchmarks. Implementation plans with cost justifications provide customers with a roadmap for achieving identified savings and efficiency gains.

Technology Advantage™

Whether temporarily employed for data acquisition or permanently deployed as part of an asset management program, Technology Advantage solutions allow customers to easily access, acquire and interpret data while also incorporating industry-leading diagnostics. This platform includes important capabilities such as:

- *Equipment monitoring via wired and wireless systems with simple integration to plant control systems*
- *Diagnostics technologies with intelligent, application-specific algorithms that predict equipment behavior and fault conditions*
- *System optimization and control technologies that respond to user-defined process parameters and adjust equipment operation to optimized or safe duty points*
- *Data visualization and asset management tools through the Technology Advantage Portal*

Providing Complete Fluid Motion Control Equipment and Services



Other Flowserve Products

Flowserve has the systems, products and experience to help processes run smarter, safer and more efficiently. In addition to its extensive pump product line, Flowserve offers high-quality seals and valves.

Flowserve Seals

Flowserve manufactures and markets highly engineered mechanical shaft seals for containing corrosive, volatile, abrasive, precious or flammable fluid. They are used on pumps and other rotating equipment.

The complete seal line includes cartridge, dry-running, metal or elastomer bellows, split and zero emission gas barrier seals. Offering innovative seal design and service on demand, Flowserve is committed to the development of new technologies to further reduce maintenance and operating costs for its customers.

Flowserve Valves

With the industry's most complete range of valves, actuators, positioners, controls, switches and steam systems, Flowserve provides customers a one-stop solution for their flow control needs.

With comprehensive research and development, engineering and global support, Flowserve valves offers valve applications solutions from simple isolation service to intelligent process control.

To learn more about Flowserve valves and seals, visit www.flowserve.com.



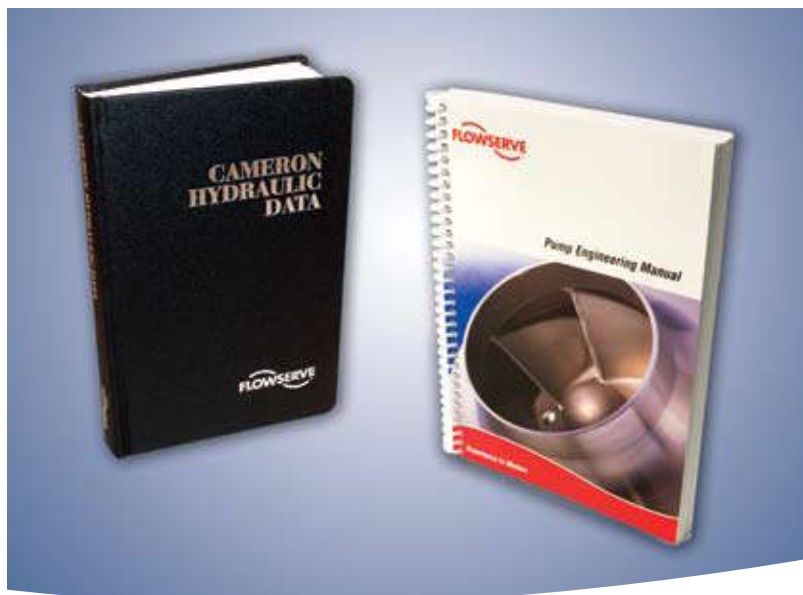

Reference Sources

Pump Industry Standards

To learn about industry standards pertaining to the design and performance of pumps contact the following organizations:

- American Petroleum Institute (API)
www.api.org
- American Society of Mechanical Engineers (ASME – ANSI) www.asme.org
- American Society of Testing and Materials (ASTM)
www.astm.org
- European Sealing Association (ESA)
www.europeansealing.com
- Europump
www.europump.org
- Deutsches Institut für Normung (DIN)
www.din.de/
- Fluid Sealing Association (FSA)
www.fluidsealing.com
- Hydraulic Institute (HI)
www.pumps.org
- International Organization for Standardization (ISO)
www.iso.org

PROS+

PROS+ proposal and order system is the most comprehensive and user-friendly pump selection program in the industry. This software ensures correct sizing and selection of Flowserve pumps to best suit your process application needs.

PROS+ is available from your local sales representative or on-line at www.flowsERVE.com.

Cameron Hydraulic Data

First published in 1926 and now in its 19th edition, the Cameron Hydraulic Data book is an indispensable aid to engineers involved with the specification, selection and application of pumping equipment. This comprehensive reference tool includes:

- Hydraulic principles and formulae
- Friction data
- Properties of common liquids
- Steam and electrical data
- Weights, dimensions, and ratings of pipe flanges and fittings
- Metric conversions

To obtain a copy of the Cameron Hydraulic Data book visit: www.cameronbook.com.

Pump Engineering Manual

This publication is devoted to explaining centrifugal pump principles. It covers the basics from application analysis and affinity laws through hydraulics and mechanical phenomena to troubleshooting.

To obtain a copy of the Pump Engineering Manual visit: www.cameronbook.com.



Index



A

AFV	41
APKC (See APKD)	43
APKD	43

B

Barge	65
BCV (see CVP)	41, 64
BP	36
BSV (see CVP)	41, 64
Byron Jackson SUBM (Oil-Filled Design) ..	44

C

CA	60
CAM	60
CAV	60
CHTA	36
CN	59
CPX3 Close Coupled	13
CPX3 ISO Standard	12
CPX3 Self-Priming	12
CPX3 Recessed Impeller	12
CPXS Magnetic Drive	13
CPXV Chemical Sump	13, 48
CS	34
CSB	35
CVP	41, 64

D

D800	23
DFSS	58
DMX	30
Drain-Titan	47, 49
DS	24
DSVP	18
DVSH	28
DVSR (non-nuclear)	31

DVSR (nuclear)	59
DVSS	58
DWEER	64

E

EC	30
ECPJ	49
EG	61
ERPNI	17
ERT	64
ESP3 Chemical Sump	48

F

F-Line	25
FRBH	21
FRBHJC	21, 46

G

GA Series	52
Gearex	52
GR Series	52
Guardian	11

H

HDB	36
HDO	37
HDR	59
HDX	31
HDX-TT	31
HED	32
HED-DS	32
HPX	16
HPXM	16
HS	54
HSB	36
HSO	37
HWMA	17
HWMA2 (See HWMA)	17
Hydraulic Decoking Systems	63

L

LC	20
LLR (See LR)	28
LNN	28
LR	28
LRV (See LR)	28
LPN	29

M

M	19
Mark 3 ASME Standard	10
Mark 3 In-Line	11
Mark 3 Lo-Flo	10
Mark 3 Recessed Impeller	11
Mark 3 Unitized Self-Primer	10
ME	24
MEN	23
MENBLOC	23
MEV	61
MF	22
MFV	45
MJ	46
MJC	46
MN	22
MNV	45
MND	20
MNR	20
Molten Salt VTP	65
MP1	53
MP1 Systems Packaging	53
MPT	21
MSP	18
MSP2 (See MSP)	18
MSX	22, 44, 47
MVE	25
MXV	45

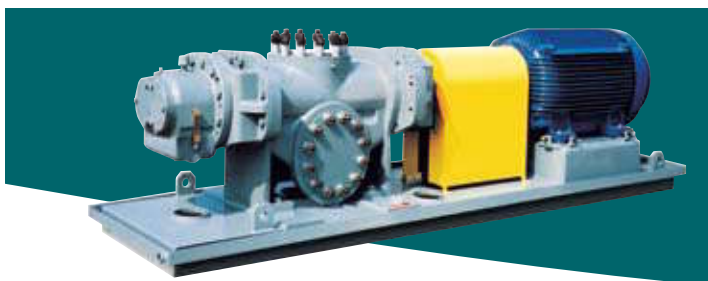

N

NM 33
N-Seals 58

P

PHL 16
Pleuger SUBM (Water-Filled Design) ... 44
Pleuger WFSD Azimuthing Thruster ... 63
Polybase 15
PolyChem GRP 14
PolyChem M-Series 15
PolyChem S-Series 14
PolyChem VGRP 14, 48
Polyshield 15
PVML 18
PVXM 17

Q

QL 40
QLC 42
QLQ 40
QLQC 42

R

R 19
RJ 46
RJC 46

S

SMP 24
SMX 25
SUBM
 (See Bryon Jackson SUBM or Pleuger SUBM) .. 44

T

Terra-Titan 47
Titan Slurry 19
TKW Cryogenic Liquid Expander 62
TSP 53

U

UZDL 30

V

V 54
VCT 41
VKW 62
VPC 42
VQE 54
VSE 54
VSMP 49
VTE 54
VTP 40

W

WCC 37
WD 33
WDF 58
WDX 33
WFSD Thruster
 (See Pleuger WFSD Azimuthing Thruster) ... 63
WIK 37
WMA (See HWMA) 17
WMA2 (See HWMA) 17
WNC-HP (See WNC) 35
WNC 35
WTB 32
WUC 42
WUC-LNG 62
WUJ 40
WX 33
WXB 35
WXB-B (See WXB) 35
WXH 34

Y

YHT 54



USA and Canada

Flowserve Corporation
5215 North O'Connor Blvd.
Suite 2300
Irving, Texas 75039-5421 USA
Telephone: 1 937 890 5839

Europe, Middle East, Africa

Flowserve Corporation
Gebouw Hagepoint
Westbroek 39-51
4822 ZX Breda
Netherlands
Telephone: 31 76 502 8920

Latin America

Flowserve Corporation
Boulevard del Cafetal
Edificio Ninina, Local 7
El Cafetal - Caracas
Venezuela 1061
Telephone: 58 212 985 3092
Telefax: 58 212 985 1007

Asia Pacific

Flowserve Pte. Ltd.
10 Tuas Loop
Singapore 637345
Telephone: 65 6771 0600
Telefax: 65 6779 4607

Bulletin FPD-100f (E/A4) Printed in USA. March 2010. © Flowserve Corporation

To find your local Flowserve representative:

For more information about Flowserve Corporation,
visit www.flowserve.com or call USA 1 800 728 PUMP (7867)