

Quality Assurance/Quality Control of Geomembrane Installation

By: Cristina Albunio, PE
ARCADIS

Quality Assurance/Quality Control of Geomembrane Installation

- Geomembrane
- Pre-Construction QA/QC
- Installation
- Construction QA/QC
- Post-Construction QA/QC
- QA/QC Costs and Benefits
- QA/QC Lessons Learned

Safety Moment



<http://www.ongov.net/911/notification.html>

Geomembranes



- Typically polyethylene based and manufactured in polymeric sheets. Examples include:
 - High Density Polyethylene (HDPE)
 - Linear Low Density Polyethylene (LLDPE)
 - Flexible Polypropylene (fPP)
 - PVC
 - Others include reinforced geomembranes
- Common differences between material types:
 - Thickness
 - Coating
 - Strength
 - Thermal properties
 - UV resistance
 - Chemical compatibilities
- Common uses
 - Landfill baseliner/cover systems
 - Engineered barriers
 - Fluid barriers
 - Vapor intrusion
 - Whenever a flexible, low permeability cover is required

Pre-Construction QA/QC

- Design
- Specifications
- Manufacturing QA/QC
- Conformance testing
- Contractor submittals and material inspections



Design

- Be familiar with the site and regulatory requirements
- Create specifications that are comprehensive and project specific based on current technical standards (GRI and ASTM)



Design Standards

- Geosynthetic Institute (GSI) – Designing with Geosynthetics by Robert M. Koerner
- USEPA Technical Guidance Document 600/R-93/182 –Quality Assurance and Quality Control for Waste Containment Facilities by David E. Daniel and Robert M. Koerner
- USEPA Technical Guidance Document 600/2.88/052 – Lining of Waste Containment and Other Containment Facilities
- Geosynthetics Research Institute (GRI) – GM Standards
 - **GM13 – Test properties and Testing Frequency for HDPE Geomembranes**
 - GM14 – Selecting Variable Intervals for Taking Geomembrane Destructive Samples Using the Method of Attributes
 - GM10 – Procedure for NCTL Test
 - GM 17 – Test properties and Testing Frequency for LLDPE Geomembranes
 - GM18 – Test properties and Testing Frequency for fPP and fPP-R Geomembranes
 - **GM19 – Seam Strength and Related properties of Thermally Bonded Polyolefin Geomembranes**
 - GM20 - Selecting Variable Intervals for Taking Geomembrane Destructive Seam Samples Using Control Charts
 - GM21 – EDPM Geomembranes
 - GM22 – PE-R Exposed Geomembranes
 - GM25 - Test properties and Testing Frequency for Scrim Reinforced LLDPE Geomembranes

• ASTM Standards



Specifications

- Different geomembrane materials and different thicknesses of the same type of geomembrane material DO NOT have the same minimum physical, mechanical and chemical properties
- NYS DEC Regulation, Chapter IV – Quality Services, Subpart 360: Landfills
 - “the project engineer must include in the construction certification report a discussion of all quality assurance and quality control testing required”
 - “testing procedures and protocols must be submitted prior to construction”
 - “the project engineer must include in the construction certification report a discussion of the approved data resulting from the quality assurance and quality control testing as required”
 - “the results of all testing must be included in the construction certification report”

Manufacturing QA/QC

- Manufacturers complete their own QA/QC during manufacturing
- Review manufacturer's QA/QC procedures
- Require manufacturer QA/QC testing and certifications be submitted by the contractor
- Must meet requirements of project specific technical specifications/GRI GM standards



GM13 Standard: Smooth HDPE Geomembrane

ENGLISH UNITS

Table 1(a) – High Density Polyethylene (HDPE) Geomembrane -Smooth

Properties	Test Method	Test Value								Testing Frequency (minimum)
		30 mils	40 mils	50 mils	60 mils	80 mils	100 mils	120 mils		
Thickness (min. ave.) • lowest individual of 10 values	D5199	nom.	Nom.	Nom.	Nom.	Nom.	Nom.	Nom.	Nom.	Per roll
Density mg/l (min.)	D 1505/D 792	-10% 0.940 g/cc	-10% 0.940 g/cc	-10% 0.940 g/cc	-10% 0.940 g/cc	-10% 0.940 g/cc	-10% 0.940 g/cc	-10% 0.940 g/cc	-10% 0.940 g/cc	200,000 lb
Tensile Properties (1) (min. ave.) • yield strength • break strength • yield elongation • break elongation	D 6693 Type IV	63 lb/in. 114 lb/in. 12% 700%	84 lb/in. 152 lb/in. 12% 700%	105 lb/in. 190 lb/in. 12% 700%	126 lb/in. 228 lb/in. 12% 700%	168 lb/in. 304 lb/in. 12% 700%	210 lb/in. 380 lb/in. 12% 700%	252 lb/in. 456 lb/in. 12% 700%		20,000 lb
Tear Resistance (min. ave.)	D 1004	21 lb	28 lb	35 lb	42 lb	56 lb	70 lb	84 lb		45,000 lb
Puncture Resistance (min. ave.)	D 4833	54 lb	72 lb	90 lb	108 lb	144 lb	180 lb	216 lb		45,000 lb
Stress Crack Resistance (2)	D5397 (App.)	300 hr.	300 hr.	300 hr.	300 hr.	300 hr.	300 hr.	300 hr.		per GRI-GM10
Carbon Black Content (range)	D 4218 (3)	2.0-3.0%	2.0-3.0%	2.0-3.0%	2.0-3.0%	2.0-3.0%	2.0-3.0%	2.0-3.0%		20,000 lb
Carbon Black Dispersion	D 5596	note (4)	note (4)	note (4)	note (4)	note (4)	note (4)	note (4)		45,000 lb
Oxidative Induction Time (OIT) (min. ave.) (5) (a) Standard OIT — or — (b) High Pressure OIT	D 3895 D 5885	100 min. 400 min.	100 min. 400 min.	100 min. 400 min.	100 min. 400 min.	100 min. 400 min.	100 min. 400 min.	100 min. 400 min.		200,000 lb
Oven Aging at 85°C (5), (6) (a) Standard OIT (min. ave.) - % retained after 90 days — or — (b) High Pressure OIT (min. ave.) - % retained after 90 days	D 5721 D 3895 D 5885	55% 80%	55% 80%	55% 80%	55% 80%	55% 80%	55% 80%	55% 80%		per each formulation
UV Resistance (7) (a) Standard OIT (min. ave.) — or — (b) High Pressure OIT (min. ave.) - % retained after 1600 hrs (9)	D 7238 D 3895 D 5885	N.R. (8) 50%	N.R. (8) 50%	N.R. (8) 50%	N.R. (8) 50%	N.R. (8) 50%	N.R. (8) 50%	N.R. (8) 50%		per each formulation

- (1) Machine direction (MD) and cross machine direction (XMD) average values should be on the basis of 5 test specimens each direction.
Yield elongation is calculated using a gage length of 1.3 inches.
Break elongation is calculated using a gage length of 2.0 in.
- (2) The yield stress used to calculate the applied load for the SP-NCTL test should be the manufacturer's mean value via MQC testing.
- (3) Other methods such as D 1603 (tube furnace) or D 6370 (TGA) are acceptable if an appropriate correlation to D 4218 (muffle furnace) can be established.
- (4) Carbon black dispersion (only near spherical agglomerates) for 10 different views:
9 in Categories 1 or 2 and 1 in Category 3
- (5) The manufacturer has the option to select either one of the OIT methods listed to evaluate the antioxidant content in the geomembrane.
- (6) It is also recommended to evaluate samples at 30 and 60 days to compare with the 90 day response.
- (7) The condition of the test should be 20 hr. UV cycle at 75°C followed by 4 hr. condensation at 60°C.
- (8) Not recommended since the high temperature of the Std-OIT test produces an unrealistic result for some of the antioxidants in the UV exposed samples.
- (9) UV resistance is based on percent retained value regardless of the original HP-OIT value.

ASTM Standards for HDPE QA/QC Testing

- D 792 Specific Gravity (Relative Density) and Density of Plastics by Displacement
- D 1004 Test Method for Initial Tear Resistance of Plastics Film and Sheeting
- D 1238 Test Method for Flow Rates of Thermoplastics by Extrusion Plastometer
- D 1505 Test Method for Density of Plastics by the Density-Gradient Technique
- D 1603 Test Method for Carbon Black in Olefin Plastics
- D 3895 Test Method for Oxidative Induction Time of Polyolefins by Thermal Analysis
- D 4218 Test Method for Determination of Carbon Black Content in Polyethylene Compounds by the Muffle-Furnace Technique
- D 4833 Test Method for Index Puncture Resistance of Geotextiles, Geomembranes and Related Products
- D 5199 Test Method for Measuring Nominal Thickness of Geotextiles and Geomembranes
- D 5397 Procedure to Perform a Single Point Notched Constant Tensile Load – (SP-NCTL) Test: Appendix
- D 5596 Test Method for Microscopic Evaluation of the Dispersion of Carbon Black in Polyolefin Geosynthetics
- D 5721 Practice for Air-Oven Aging of Polyolefin Geomembranes
- D 5885 Test method for Oxidative Induction Time of Polyolefin Geosynthetics by High Pressure Differential Scanning Calorimetry
- D 5994 Test Method for Measuring the Core Thickness of Textured Geomembranes
- D 6370 Standard Test Method for Rubber-Compositional Analysis by Thermogravimetry (TGA)
- D 6693 Test Method for Determining Tensile Properties of Nonreinforced Polyethylene and Nonreinforced Flexible Polypropylene Geomembranes
- D 7238 Test Method for Effect of Exposure of Unreinforced Polyolefin Geomembrane Using Fluorescent UV Condensation Apparatus
- D 7466 Test Method for Measuring the Asperity Height of Textured Geomembranes

Conformance Testing

- Conduct conformance testing with an independent laboratory
- Random samples should be taken at a pre-determined frequency
- Confirms manufacturer's QA/QC tests
- Demonstrates independent testing was performed by the owner/engineer



Contractor Submittals and Material Inspections

- Require submittal of shop drawings and proposed panel layout diagram from the contractor
- Record and track all submittals and data related to the pre-construction QA/QC testing
- Perform an inventory of geomembrane materials on-site
- Confirm on-site materials match the pre-construction QA/QC data

Installation

- Subgrade is prepared
- Typically pulled while suspended from excavator
- Placed in sheets (panels) side by side
- Panels are welded together to form continuous low permeability barrier

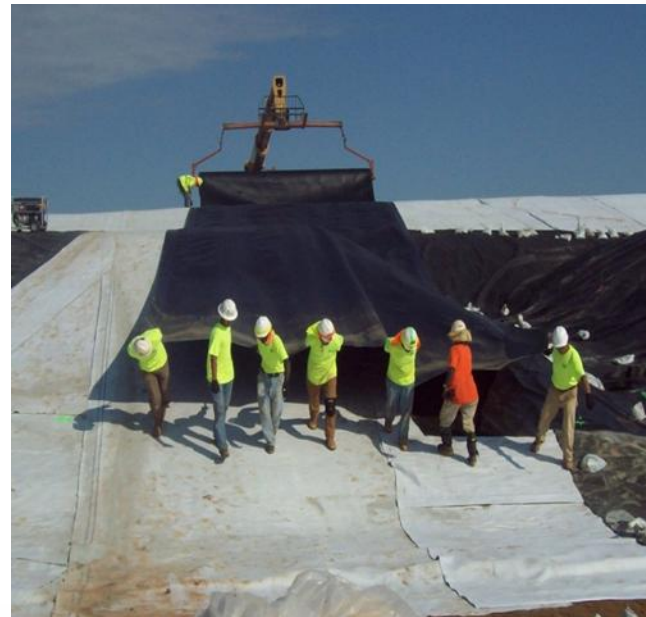

Installation

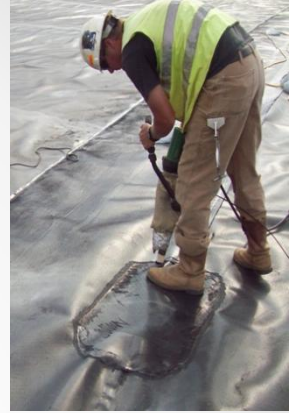

- Hot Wedge Seaming



- A thermal technique which melts the two opposing geomembrane surfaces to be seamed by running a hot metal wedge or knife between them
- Pressure applied to the top or bottom geomembrane, or both, to form a continuous bond
- Referred to as dual hot wedge seams or double-track seams

- Extrusion Fillet Seaming



- Involves extruding molten resin at the edge of an overlapped geomembrane on another to form a continuous bond
- A depreciated method called “extrusion flat” seaming extrudes the molten resin between two overlapped sheets
- Surfaces which molten resin is applied must be suitably prepared by grinding or buffing (removes oxidation)

Hot Wedge Welding

- Long uninterrupted seems along the edges of two panels
- Creates air channel between the two welded tracks



Repairs

- Involves patching of holes using a piece of geomembrane
- Typically extrusion welded
- Examples include pipe boots, T-seams, destructive testing locations and any damaged areas

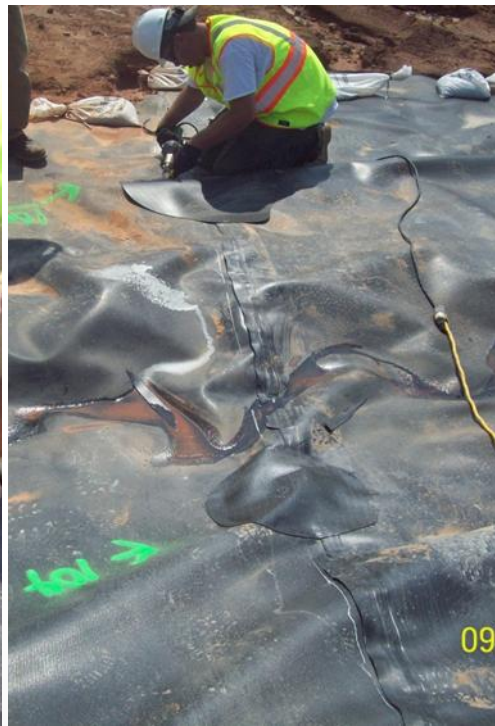

Construction QA/QC

- Trial welds
- Non-destructive testing
- Destructive testing
- Documentation
- Survey

Trial welds

- Used to establish machine settings (temperature, pressure and speed) under specific conditions (air temperature and humidity)
- Each seamer is assigned a seaming device and generates trial welds on specific material combinations
- Frequent trial welds needed (typically every 4 hours, new material combinations, new machine, changes in weather occur)
- ASTM D 6392 - Standard Test Method for Determining the Integrity of Non-reinforced Geomembrane Seams Produced Using Thermo-Fusion Methods
 - Uses field tensiometer
 - Must meet strength requirements provided in the technical specifications/GM19 – Seam Strength and Related Properties of Thermally Bonded Polyolefin Geomembranes
- Documentation includes welder ID, machine ID, weld type, weather conditions peel/shear test results and failure type.



Non-Destructive Testing

- Performed on 100% of all field seams
- Air Channel Testing for hot wedge welds:
 - Seal ends of seam
 - Insert pressure gauge into air channel
 - Pressurize channel with air (approximately 30 psi depending on material type)
 - Observed pressure for a minimum of 2 minutes (5 minutes is common).
 - Seam fails if pressure drop exceeds specification (typically more than 2-3 psi in 5 minutes)
 - Failed seams are identified for repair and retested
 - Documentation includes seam ID, tester ID, and starting/finishing times and pressures



Non-Destructive Testing

- Vacuum box testing for extrusion welds
 - Spread soap and water solution along seams
 - Place vacuum box over area with solution
 - Pressurize vacuum box to 4 to 8 psi for a minimum of 10 seconds
 - Observe through vacuum box window for evidence of leaks (typically bubbles form through leaks)
 - Seams are tested in a overlapping manner (2 inch minimum overlap)
 - Failed seam areas are identified for repair, repaired, and retested
 - Documentation includes seam/repair ID, tester ID, and pass/fail test result



Destructive Testing

- Typically performed once per 500 linear feet
- Portions of seams are removed for testing
- Portion of sample is cut and field tested in tensiometer (typically 5 peel tests and 5 shear tests)
- Portion of sample is shipped to independent laboratory
- Destructive test locations are repaired
- Documentation includes destruct ID, seam ID, welder ID, and field strength testing results



Seam testing

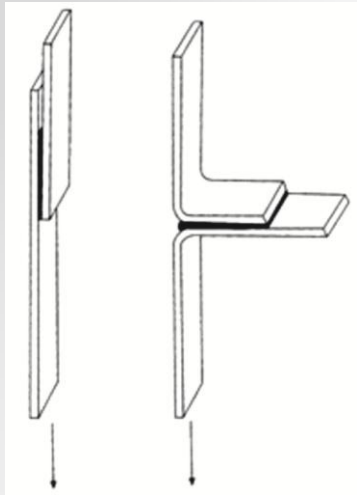

- Shear and peel tests for maximum load and maximum strain
- GM19 – Geomembrane Seams
- ASTM D751 – Standard Test Methods for Coated Fabrics
- ASTM D6392 – Standard Test Method for Determining the Integrity of Nonreinforced Geomembrane Seams Produced Using Thermo-Fusion Methods
- Typically the material will break before the seam will

Schematic of Untested Specimen

Types of Break	Location of Break Code	Break Description
	AD	Adhesion Failure
	BRK	Break in sheeting Break can be in either top or bottom sheet
	SE1	Break in outer edge of seam. Break can be in either top or bottom sheet.
	SE2	Break at inner edge of seam through both sheets.
	AD-BRK	Break in first seam after some adhesion failure Break can be in either top or bottom sheet
	SIP	Separation in the plane of the sheet, Break can be in either top or bottom sheet

GM19 Standard: Seam Strength

Table 1(a) – Seam Strength and Related Properties of Thermally Bonded **Smooth and Textured** High Density Polyethylene (HDPE) Geomembranes (**English Units**)

Geomembrane Nominal Thickness	30 mils	40 mils	50 mils	60 mils	80 mils	100 mils	120 mils
Hot Wedge Seams⁽¹⁾							
shear strength ⁽²⁾ , lb/in.	57	80	100	120	160	200	240
shear elongation at break ⁽³⁾ , %	50	50	50	50	50	50	50
peel strength ⁽²⁾ , lb/in.	45	60	76	91	121	151	181
peel separation, %	25	25	25	25	25	25	25
Extrusion Fillet Seams							
shear strength ⁽²⁾ , lb/in.	57	80	100	120	160	200	240
shear elongation at break ⁽³⁾ , %	50	50	50	50	50	50	50
peel strength ⁽²⁾ , lb/in.	39	52	65	78	104	130	156
peel separation, %	25	25	25	25	25	25	25

Notes for Tables 1(a) and 1(b):

1. Also for hot air and ultrasonic seaming methods
2. Value listed for shear and peel strengths are for 4 out of 5 test specimens; the 5th specimen can be as low as 80% of the listed values
3. Elongation measurements should be omitted for field testing

Table 1(b) – Seam Strength and Related Properties of Thermally Bonded **Smooth and Textured** High Density Polyethylene (HDPE) Geomembranes (**S.I. Units**)

Geomembrane Nominal Thickness	0.75 mm	1.0 mm	1.25 mm	1.5 mm	2.0 mm	2.5 mm	3.0 mm
Hot Wedge Seams⁽¹⁾							
shear strength ⁽²⁾ , N/25 mm.	250	350	438	525	701	876	1050
shear elongation at break ⁽³⁾ , %	50	50	50	50	50	50	50
peel strength ⁽²⁾ , N/25 mm	197	263	333	398	530	661	793
peel separation, %	25	25	25	25	25	25	25
Extrusion Fillet Seams							
shear strength ⁽²⁾ , N/25 mm	250	350	438	525	701	876	1050
shear elongation at break ⁽³⁾ , %	50	50	50	50	50	50	50
peel strength ⁽²⁾ , N/25 mm	170	225	285	340	455	570	680
peel separation, %	25	25	25	25	25	25	25

Documentation

- Typical field documentation includes forms for:
 - Subgrade Acceptance
 - Trial Weld Testing (All Seam Types)
 - Panel Placement
 - Air Channel Testing (For Hot Wedge Seams)
 - Vacuum Box Testing (For Extrusion Welded Seams)
 - Destructive Seam Testing
 - Repairs

Survey

- Includes panels, seams, repairs and destructs



Post-Construction QA/QC

- Cover with overlying materials and/or using sandbags to prevent damage from wind
- Cover with overlying materials/soil to minimize runoff and protect from UV
- **Careful placement of overlying materials**
- Completion of all outstanding contractor submittals QA/QC documentation
- Leachate/groundwater monitoring

QA/QC Costs

- Includes testing before, during and following construction
- Lab costs, on-site personnel, QA/QC training, construction costs, repair costs (following destructive testing)
- Estimated cost for CQA for single composite liner in \$12,500 - \$30,000 per acre ⁽¹⁾
- Comparable to material costs ⁽²⁾

References:

(1) Landfill Liner CQA: A summary of Real Costs and a Question of True Value by J.A. Shepard, C.A. Rivette and R.C. Nava; (2) Costs and Benefits of Geomembrane Liner

- Installation CQA by G.T. Darilek and D.I. Laine of Leak Location Services, Inc.

QA/QC Benefits

- Meet and exceed regulatory requirements
- Reduced risk of leakage through liner
- Lower production of leachate and/or groundwater impact
- Reduced long term Operation & Maintenance costs

Leakage Through Liner

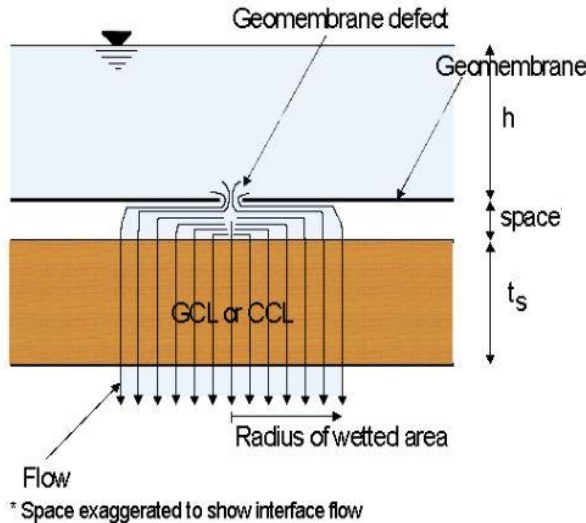

For a circular defect with a diameter of d:

$$\frac{Q}{A} = n \cdot 0.976 C_{qo} \cdot [1 + 0.1 \cdot (h/t_s)^{0.95}] \cdot d^{0.2} \cdot h^{0.9} \cdot k_s^{0.74}$$

Q = leakage rate

A = geomembrane area

n = number of defects

C_{qo} = contact quality factor

h = hydraulic head

t_s = thickness of soil layer

k_s = hydraulic conductivity of soil layer

Assuming 1 foot of head, 6 feet of underlying soil having k=1x10⁻⁷ m/s, good soil/liner contact

One 0.1 inch diameter defect... 3 gpad

One 2 inch diameter defect.... 6 gpad

One 12 inch diameter defect.... 8 gpad

Lessons Learned

- Technical specifications
 - should be project specific and updated as standards change
- Vacuum box testing
 - Done in presence of QA/QC inspector
 - Inspect neoprene gasket to make sure it is in good condition
 - Make sure window is clean/clear
- Air channel testing
 - Done in presence of a QA/QC inspector
 - Release at end furthest from gauge
 - Make sure air channel needles and gauges are operational, clear and unplugged
- Trial seams
 - Be aware of who performs the trial seams
 - Seamers should not switch seaming devices or change machine settings without performing a new trial weld
- Document everything
- Review all project documents (drawings, technical specifications, etc.) with the geomembrane installer prior to installation
- Welding material should be identical to the geomembrane material being installed

Questions

1 – True/False - Regardless of the thickness of a material, all geomembranes of the same material type have the same minimum physical, mechanical and chemical properties.

2- When testing geomembrane seams, will the seam or the material typically fail first?

3- Who is responsible for performing and submitting pre-construction QA/QC tests to the design engineer/owner?

4- Which QA/QC tests are performed on 100% of all field seams?

5- What kind of information does GRI-GM19 contain?