



ज्ञान ज्योति से मार्गदर्शन  
*To Beam As A Beacon of Knowledge*

# RAIN WATER HARVESTING

October 2015

**Indian Railways Institute of Civil Engineering  
Pune 411001**

First Edition : August 2006

Second Edition : October 2015  
Revised Edition

Price ₹ 30/-



ज्ञान ज्योति से मार्गदर्शन  
*To Beam As A Beacon of Knowledge*

# RAIN WATER HARVESTING

October 2015

INDIAN RAILWAYS INSTITUTE OF CIVIL ENGINEERING,  
Pune 411001



## **Preface to the Second Edition**

With regard to water, urban areas in India are facing a paradoxical situation these days. On the one hand there is acute water scarcity and on the other, the streets are flooded during rains. This reflects managerial inefficiency of the urban local bodies to use the surplus water of the rainy season to overcome the deficiency in other seasons. The current centralized water supply paradigm is definitely unsustainable and extremely high on energy consumption. The shortage of ground water gets more pronounced with urbanization and limited open areas available for recharge of ground water. Water shortage may result in social conflicts, demonstrations, protests and road- blockades. In the given situation rain water harvesting can prove to be a solution.

An alternative paradigm for more sustainable water availability is harvesting rainwater, storing it in tanks, and recharging groundwater. In India, Rain Water Harvesting has been in practice for more than 4000 years. The physical and chemical properties of rainwater are mostly superior to that of groundwater.

The first step could be to initiate domestic rooftop rainwater harvesting. In a house the highest point is the rooftop. However, common property resource issues have to be considered at larger level for rain water harvesting. Various government bodies of India have issued policy directives for encouraging this practice especially since 2002. In 2013 Ministry of Railway has also issued policy guideline to adopt rain water harvesting in all projects.

The book on “Rain water Harvesting” will create awareness and accordingly will guide engineers in using this technology in a environment friendly manner.

12<sup>th</sup> October, 2015

**Vishwesh Chaubey**  
**Director**

Indian Railways Institute of  
Civil Engineering, Pune.  
director@iricen.gov.in

## **Preface to the First Edition**

We, the human beings, are largely dependent on water for our survival. Although water is as important for survival of human beings as much as food, air etc. but we hardly pay any attention for its economical use and conservation of this precious resource.

Due to indiscriminate pumping of ground water, the water table has already gone down abnormally and if we do not wake up even now then our future generations may have to face severe crisis of water. The rains are important source of water and if we can harvest rain water, the scarcity of water can be eliminated altogether. Therefore, it is our bounden duty to conserve the rain water in the form of rain water harvesting.

The book on "Rain Water Harvesting" is an attempt by IRICEN to propagate the concept of rain water harvesting which can be effectively implemented in our office and residential establishments. It is hoped that this will serve as a helpful guide to the field engineers.

**Shiv Kumar**  
DIRECTOR  
IRICEN, Pune

## **Acknowledgement**

The rapid development of cities and consequent population explosion in urban areas has led to depletion of surface water resources. For fulfillment of daily water requirement, indiscriminate pumping of ground water is being resorted to, leading to lowering of ground water table. At the same time the rain water is not being conserved which ultimately goes waste. To avoid this imbalance, conservation of rain water in the form of rain water harvesting is the only solution.

Rain water harvesting can be effectively implemented in our office and residential complexes for conservation of rain water. The subject has assumed lot of significance in the present scenario. This has been included in Indian Railway Works Manual 2000 vide correction slip no. 10 dated 17.02.05 also. This publication is an attempt to compile all the relevant information regarding various methods commonly in use. These methods can be used by field engineers for designing and implementing Rain Water Harvesting systems.

Efforts have been made to make the book more useful for the field engineers. In this effort, the IRICEN staff and faculty have contributed immensely, notably among them are Mrs. Gayatri Nayak and Shri Sunil Pophale. I am particularly thankful to Shri N.C. Sharda, Senior Professor/Works for his valuable suggestions and proof checking and Shri Praveen Kumar, Professor/Computers for providing logistic assistance for printing of the book.

Above all, the author is grateful to Shri Shiv Kumar, Director, IRICEN for his encouragement and suggestions for improving the publication.

**A. K. Gupta**  
Professor/Track  
IRICEN/Pune





# CONTENTS

## CHAPTER-1 GENERAL

1 - 11

- 1.0 Introduction
- 1.1 Hydrologic cycle
- 1.2 Advantages of rain water
- 1.3 Rain water harvesting
- 1.4 Advantages of rain water harvesting
- 1.5 From where to rain water harvesting
- 1.6 Rain water harvesting potential
- 1.7 Factors affecting run off from catchment
- 1.8 Important points relating to water storage and recharging

## CHAPTER-2 METHODS OF HARVESTING RAIN WATER

12 - 31

- 2.1 Rain water harvesting methods
  - 2.1.1 Storing rain water for direct use
  - 2.1.2 Recharging ground water aquifers from roof top runoff
  - 2.1.3 Recharging ground water aquifers with runoff from ground areas
- 2.2 Components of rain water harvesting
  - 2.2.1 Catchment area
  - 2.2.2 Coarse mesh/leaf screen
  - 2.2.3 Gutter
  - 2.2.4 Down spout/Conduit
  - 2.2.5 First flushing device

- 2.2.6 Filter
- 2.2.7 Settlement tank
- 2.2.8 Storage tank

<b>CHAPTER-3 RECHARGING SUBSURFACE AQUIFERS</b>	<b>32 - 39</b>
<b>3.1 Methods of recharging subsurface aquifers</b>	
3.1.1 Through recharge pit	
3.1.2 Recharge through abandoned hand pump	
3.1.3 Recharge through abandoned dug well/ open well	
3.1.4 Through recharge trench	
3.1.5 Recharge through shaft	
3.1.6 Recharge trench with bore	
<b>CHAPTER-4 CASE STUDY</b>	<b>40 - 44</b>
4.1 Introduction	
4.2 Rain water harvesting at IRICEN hostel	
<b>CHAPTER-5 QUALITY OF WATER</b>	<b>45 - 50</b>
<b>REFERENCES</b>	<b>51</b>

# CHAPTER - 1

## GENERAL

It is said that "If third world war take places it will be on water". Already so many water disputes are going on in our country between neighboring states for sharing river water. Same situation of sharing river water also exists with neighboring countries like Pakistan, Nepal and Bangladesh. The basic reason of all these disputes is scarcity of water and increasing requirement for human consumption as well as for industrialization.

We, the human beings, are largely dependent on water for our survival. Although water is as important for survival of human beings as is food, air etc. but we hardly pay any attention for its economical use and conservation of this precious resource. This is resulting in scarcity of water.

Due to indiscriminate pumping of ground water, the water table has already gone down abnormally in many parts of our country and if we do not wake up even now, then our future generations may have to face severe crisis of water.

In Delhi the water level in 1960 was, by and large, within 4 to 5 m from ground level but by 2001 it has gone down by 2-6 m in alluvial areas, 8-20 in south west district and 8-30 in south district. Due to rapid urbanization and indiscriminate pumping ground water table has gone very deep and due to high content of soluble solid, it has become un-potable in many area.

The rains are important source of water and if we can harvest rain water, the scarcity of water can be eliminated upto large extent. A major portion of rainwater that falls on earth surface runoff from stream to river to sea. On average only 8% of total rainfall recharges ground aquifers. This can be enhanced upto

50% with proper rainwater harvesting. Therefore, it is our bounden duty to conserve the rain water in the form of rain water harvesting.

Few basic facts we should know:

- Only 3% of water on earth is available for human use.
- Only 10% rain water is harvested currently. This can be enhanced to 50% if adopted as habit or movement. This can solve water problems of major part of country.
- On an average rains, occur only for about 100 hours every year.

Legislation on Rain Water Harvesting in India

- Under the sec 15 of Environment (protection) Act 1986 central ground water authority (ministry of water resources) has made mandatory to adopt rain water harvesting system for certain types of buildings /institutions located in specified regions of national capital territory.
- Ministry of Environment & forest (Govt. of India) has circulated draft Gazette Nomination regarding RWH in hilly area of entire country.
- New Delhi - MOUD has made RWH mandatory since June 2001 if roof area = 100sqm or plot area = 1000sqm.
- Mumbai: RWH mandatory since Oct 2002 for new buildings with area = 1000 sqm.
- Chennai: RWH has been made mandatory in all new buildings of three or more storeys.
- Hyderabad: RWH made mandatory since June 2001 if area = 300 sqm.
- Kanpur : RWH made mandatory for new buildings with area = 1000 sqm.
- Indore :
  - RWH made mandatory for new buildings if area = 250 sqm.

- Rebate of 6% in property tax as incentive for RWH.
- Rajasthan: RWH made mandatory for new buildings in urban areas if plot area = 500 sqm.
- Haryana:
  - HUDA has made RWH mandatory for new buildings in urban areas irrespective of area.
  - CGWA has asked all institutions and residential buildings in notified areas of Gurgaon and adjacent industrial areas to go for RWH.

Ministry of Railways (Railway board vide their letter dated 2013/JMB/9/1 dtd 09-9-2013 has issued policy instruction to adopt Rain water harvesting scheme in all projects.

## 1.0 Introduction

Water is the most common or major substance on earth, covering more than 70% of the planet's surface. All living things consist mostly of water. For example, the human body is about two third water. World wide distribution of water is given in table 1.1 of the total volume of water, only 2 percent (over 28,000,000 Km<sup>3</sup>) is fresh water, which can be used for consumption and for agriculture as given in table 1.2. The average runoff in the river system of India has been assessed as 1869 km<sup>3</sup>, of this, the utilizable portion by conventional storage and diversion is estimated as about 690 km<sup>3</sup>. In addition, there is substantial replenishable ground water potential in the country estimated at 432 km<sup>3</sup>. The per capita availability of water at the national level has reduced from about 5,177 m<sup>3</sup> in the year 1951 to the present level of 1,869 m<sup>3</sup>. For improving per capita water availability in the country, replenishment of ground water resources is a necessity which can be done very effectively through rain water harvesting.

**Table 1.1 World-wide distribution of water**

<b>S N</b>	<b>Water Type</b>	<b>Volume (1000km<sup>3</sup>)</b>	<b>Percentage of total Global Volume</b>
1	Ocean	1,370,323	94.200
2	Ground water (fresh & saline)	60,000	4.100
3	Glaciers	24,000	1.650
4	Lakes and reservoirs	280	0.019
5	Soil moisture	85	0.006
6	Atmospheric water	14	0.001
7	River water	1.2	0.001
	<b>Total</b>	<b>1,454,703.2</b>	<b>100.000</b>

**Table 1.2 World-wide distribution of fresh water**

<b>S N</b>	<b>Water Type</b>	<b>Volume (1000km<sup>3</sup>)</b>	<b>Percentage of total Global Volume</b>
1	Glaciers	24,000	85.000
2	Ground water	4,000	14.000
3	Lakes and reservoirs	155	0.600
4	Soil moisture	83	0.300
5	Atmospheric water	14	0.050
6	River water	1.2	0.004
	<b>Total</b>	<b>28,253.2</b>	<b>100.00</b>

## Rain Water Harvesting:

The concept of rain water harvesting means “Collecting Rain water when and wherever it falls for future use”...It is just like “bank account where you deposit the money when it is surplus & with draw when it is deficient”.

As most of rainfall water goes waste in form of surface run off to stream, river and sea, simple technique need to be developed to collect and store this water in storage tank or direct this water to recharge ground water acquifers (water bearing strata) to be tapped later on for use in dry periods.

### 1.1 Hydrologic Cycle

The never-ending exchange of water from the atmosphere to the oceans and back is known as the hydrologic cycle (Fig. 1.1). This cycle is the source of all forms of precipitation (hail, rain, sleet, and snow), and thus of all the water.

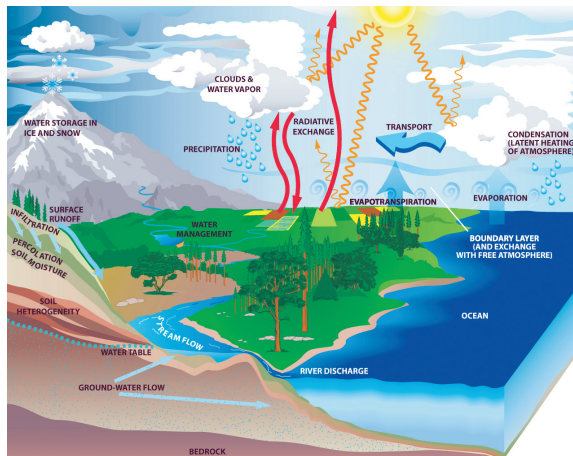

**Fig. 1.1 Hydrologic cycle**

Precipitation stored in streams, lakes and soil evaporates while water stored in plants transpires to form clouds which store the water in the atmosphere.

Currently, about 75% to 80% of conventional water supply is from lakes, rivers and wells. Making the most efficient use of these limited and precious resources is essential. Otherwise, scarcity of water will be faced by our future generations.

## **1.2 Advantages of Rain Water**

The rain water's environmental advantage and purity over other water options makes it the first choice, even though the precipitation cycle may fluctuate from year to year.

### **a. Environmental Advantage**

Collecting the rain that falls on a building and using the same for various purposes is a simple concept. Since the rain you harvest is independent of any centralized system, you are promoting self-sufficiency and helping to foster an appreciation for this essential and precious resource. The collection of rain water not only leads to conservation of water but also energy since the energy input required to operate a centralized water system designed to treat and pump water over a vast service area is bypassed. Rain water harvesting also lessens local erosion and flooding caused by runoff from impervious cover such as pavement and roofs.

### **b. Qualitative Advantage**

A compelling advantage of rain water over other water sources is that it is one of the purest sources of water available. Indeed, the quality of rain water is an overriding incentive for people to choose rain water as their primary water source, or for specific uses such as watering houseplants and gardens. Rain water quality almost always exceeds that of ground or surface water as it does not come into contact with soil and rocks where it dissolves salts and minerals and it is not exposed to many of the pollutants that often are discharged into surface waters such as rivers, and can contaminate groundwater. Rain water's purity also makes it an attractive water source for certain industries for which pure water is a requirement.



### **1.3 Rain Water Harvesting**

For our water requirement we entirely depend upon rivers, lakes and ground water. However rain is the ultimate source that feeds all these sources. Rain water harvesting means to make optimum use of rain water at the place where it falls i.e. conserve it and not allow to drain away and cause floods elsewhere. The rain water harvesting may be defined as the technique of collection and storage of rain water at surface or in sub-surface aquifer before it is lost as surface run off.

### **1.4 Advantages of Rain Water Harvesting**

- (a) Promotes adequacy of underground water
- (b) Mitigates the effect of drought
- (c) Reduces soil erosion as surface run-off is reduced
- (d) Decreases load on storm water disposal system
- (e) Reduces flood hazards
- (f) Improves ground water quality / decreases salinity (by dilution)
- (g) Prevents ingress of sea water in subsurface aquifers in coastal areas
- (h) Improves ground water table, thus saving energy (to lift water)
- (i) The cost of recharging subsurface aquifer is lower than surface reservoirs
- (j) The subsurface aquifer also serves as storage and distribution system
- (k) No land is wasted for storage purpose and no population displacement is involved
- (l) Storing water underground is environment friendly
- (m) Rainwater is bacteriological pure, free from organic matter and soft in nature

- (n) Rainwater can be harnessed at place of need & time of need
- (o) Recharged aquifers also serve as distribution system & water can be harnessed by just putting a hand pump at convenient location
- (p) The infrastructure required for rainwater harvesting are simple & economical.

## **1.5 From Where to Harvest Rain Water**

- i. Roof top to storage tank or Ground water recharging point
- ii. Unpaved area direct seepage to ground water
- iii. Water bodies like ponds, tanks and lakes
- iv. Storm water drains directed to recharge ground water

## **1.6 Rain Water Harvesting Potential**

The total amount of water that is received in the form of rainfall over an area is called the rain water endowment of that area. Out of this, the amount that can be effectively harvested is called rain water harvesting potential.

All the water which is falling over an area cannot be effectively harvested, due to various losses on account of evaporation, spillage etc. Because of these factors, the quantity of rain water which can effectively be harvested is always less than the rain water endowment. The collection efficiency is mainly dependent on factors like runoff coefficient and first flush wastage etc.

Runoff is the term applied to the water that flows away from catchments after falling on its surface in the form of rain. Runoff from a particular area is dependent on various factors i.e. rainfall pattern and quantity, catchment area characteristics etc. For determining rainfall quantity, the rainfall data preferably for a period of at least 10 years is required. This data can be collected from meteorological department.

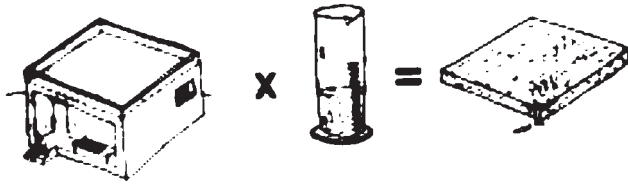

$$\text{Area of catchment} \times \text{Amount of rainfall} = \text{Rain water endowment}$$

For determining the pattern of rainfall, the information may be collected either from meteorological department or locally. The pattern of rainfall in a particular catchment area influence the design of rain water harvesting system. In areas where rainfall is more but limited to very short period in a year, big storage tanks would be required to store rain water, if we are collecting rain water in storage tanks for direct use. In such areas, it is preferable to use rain water for recharging of ground water aquifers, if feasible, to reduce the cost of rain water harvesting system.

### 1.7 Factor Affecting Run Off from Catchment

- i. Rainfall - quantity, pattern, intensity & duration

High intensity in less duration may get same quantity but may get wasted due to high surface run off due to less infiltration capacity whereas mild rainfall with long duration will help in recharging ground water.

- ii. Catchment area characteristic

Unpaved surface have greater capacity of retaining rain water & similarly green patches of grass can retain large proportion of rainwater.

Runoff depends upon the area and type as well as surface of catchment over which it falls as well as surface features. Runoff can be generated from both paved and unpaved catchment areas. Paved surfaces have a greater capacity of retaining water on the surface and runoff from unpaved surface is less in comparison to paved surface. In all calculations for runoff estimation, runoff

coefficient is used to account for losses due to spillage, leakage, infiltrations catchment surface wetting and evaporation, which will ultimately result into reduced runoff. Runoff coefficient for any catchment is the ratio of the volume of water that run off a surface to the total volume of rainfall on the surface. The runoff coefficient for various surfaces is given in table 1.3.

**Table 1.3 Runoff coefficients for various surfaces**

<b>S. No.</b>	<b>Type of catchment Roof catchments</b>	<b>Coefficients</b>
1	Tiles	0.8 - 0.9
2	Corrugated metal sheets Ground surface coverings	0.7 - 0.9
3	Concrete	0.6 - 0.8
4	Brick pavement Untreated ground catchments	0.5 - 0.6
5	Soil on slopes less than 10%	0.0 - 0.3
6	Rocky natural catchments	0.2 - 0.5

Source: Pacey, Arnold and Cullis, Adrian 1989, Rain water Harvesting: The collection of rainfall and runoff in rural areas, Intermediate Technology Publications, London pg-55.

Based on the above factors, the water harvesting potential of site could be estimated using the following equation:

Rain Water harvesting potential = Amount of Rainfall x Area of catchment x Runoff coefficient

The calculation for runoff can be illustrated using the following example:

Consider a building with flat terrace area (A) of 100 sqm located in Delhi. The average annual rainfall (R) in Delhi is approximately 611mm. The runoff coefficient (C) for a flat terrace may be considered as 0.85.

Annual water harvesting potential from 100

$$= A \times R \times C$$

$$= 100 \times 0.611 \times 0.85$$

$$= 51.935 \text{ cum,}$$

i.e. 51,935 liters

## **1.8 Important Points Relating to Water Storage and Recharging**

- i. It is estimated that only 10 to 25% of rain water is utilized to charged ground water but artificially with rain water harvesting, it can be charged upto 50% (para 2.6.3 of manual of rain water harvesting & conservation - Govt of India)
- ii. Settlement tank need to be constructed in area. This helps in two ways, it arrest silt & floating impurities and secondly allow standing water to percolate in to soil to finally recharge ground water. Apart from the removing silt from desilting chamber, it act like a buffer in case of excess rain fall to arrest surface run off & store excess water. Its size can be decided on the basis of size of catchment, intensity of rain fall & rate of recharge depend on geological data like porosity, permeability etc of area.



## CHAPTER - 2

### METHODS OF HARVESTING RAIN WATER

#### 2.1 Rain Water Harvesting Methods

There are three methods of harvesting rain water as given below:

- (a) Storing rain water for direct use (Fig. 2.1)
- (b) Recharging ground water aquifers, from roof top run off (Fig. 2.2)
- (c) Recharging ground water aquifers with runoff from ground area (Fig. 2.3)

##### 2.1.1 Storing rain water for direct use

In place where the rains occur throughout the year, rain water can be stored in tanks (Fig. 2.1). However, at places where rains are for 2 to 3 months, huge volume of storage tanks would have to be provided. In such places, it will be more appropriate to use rain water to recharge ground water aquifers rather than to go for storage. If the strata is impermeable, then storing rain water in storage tanks for direct use is a better.

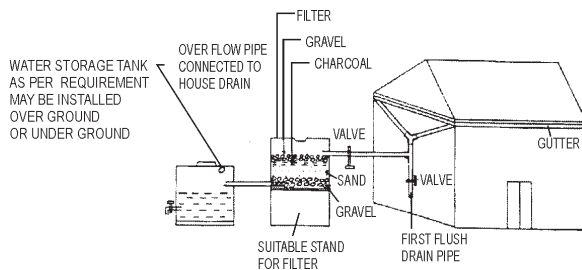

**Fig. 2.1 Storing rain water for direct use method.**

Similarly, if the ground water is saline/unfit for human consumption or ground water table is very deep, this method of rain water harvesting is preferable.

### 2.1.2. Recharging ground water aquifers from roof top run off

Rain water that is collected on the roof top of the building may be diverted by drain pipes to a filtration tank (for bore well, through settlement tank) from which it flows into the recharge well, as shown in Fig.2.2. The recharge well should preferably be shallower than the water table. This method of rain water harvesting is preferable in the areas where the rainfall occurs only for a short period in a year and water table is at a shallow depth. The various methods of recharging ground water aquifers from roof top runoff are discussed separately in Chapter 3.

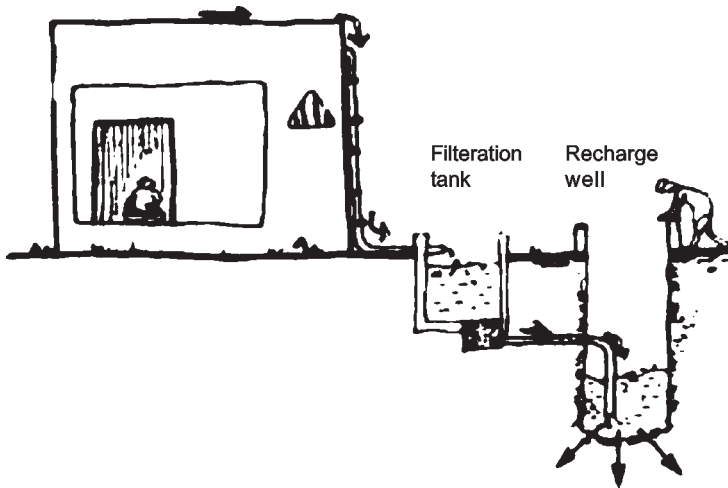
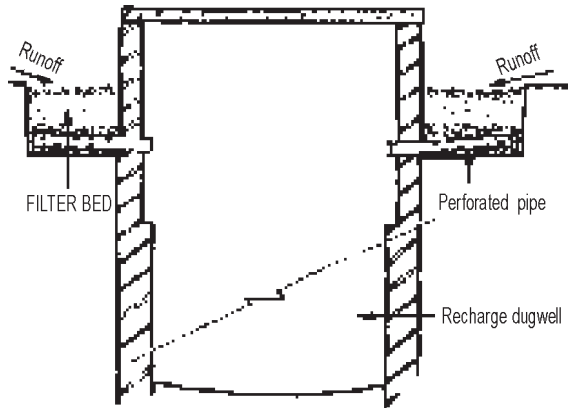

Fig. 2.2 Recharging ground water aquifers from roof top run off.

### 2.1.3 Recharging ground water aquifers with runoff from ground areas

The rain water that is collected from the open areas may be diverted by drain pipes to a recharge dug well / bore well through filter tanks as shown in Fig.2.3. The abandoned bore well/dug well can be used cost effectively for this purpose. The various methods of recharging ground water aquifers with runoff from ground areas are discussed separately in Chapter 3.



**Fig. 2.3 Recharging ground water aquifers with runoff from ground areas.**

## 2.2 Components of Rain Water Harvesting

The rain water harvesting system consists of following basic components –

- (a) Catchment area
- (b) Coarse mesh / leaf screen
- (c) Gutter
- (d) Down spout or conduit
- (e) First flushing device



- (f) Filter
- (g) Storage tank
- (h) Recharge structure

### **2.2.1 Catchment area**

The catchment area is the surface on which the rain water falls. This may be a roof top or open area around the building. The quality of water collected from roof top is comparatively much better than collection from the ground. Rain water harvested from catchment surfaces along the ground should be used for lawn watering, flushing etc., because of increased risk of contamination. This water can also be used for recharging ground aquifers after proper filtration.

The rain water yield varies with the size and texture of the catchment area. A smooth, cleaner and more improvised roofing material contributes to better water quality and greater quantity with higher value of runoff coefficient. (refer table 1.3 for runoff coefficient)

When roof of the house is used as the catchment for collecting the rain water, the type of roof and the construction material affect the runoff coefficient and quality of collected water. Roofs made of RCC, GI sheets, corrugated sheets, tiles etc. are preferable for roof top collection. But thatched roofs are not preferred as these add colour and dissolved impurities to water. Water to be used for drinking purpose should not be collected from roof with damaged AC sheets or from roofs covered with asphalt and lead flashing or lead based paints as the lead contamination may occur in the collected water.

### **2.2.2 Coarse mesh / leaf screen**

To prevent the entry of leaves and other debris in the system, the coarse mesh should be provided at the mouth of inflow pipe for flat roofs as shown in Fig. 2.4.

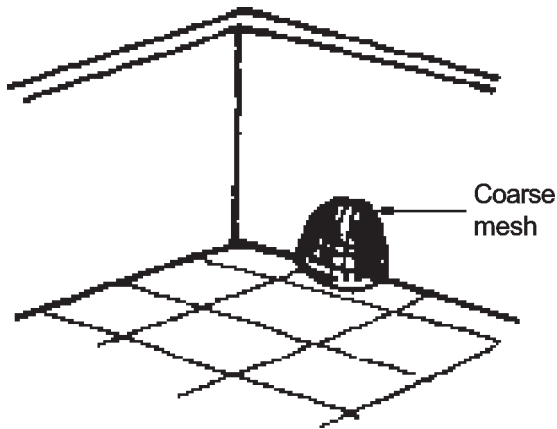

**Fig. 2.4 Coarse mesh**

For slope in roofs where gutters are provided to collect and divert the rain water to downspout or conduits, the gutters should have a continuous leaf screen, made of  $\frac{1}{4}$  inch wire mesh in a metal frame, installed along their entire length, and a screen or wire basket at the head of the downspout (Fig. 2.5).

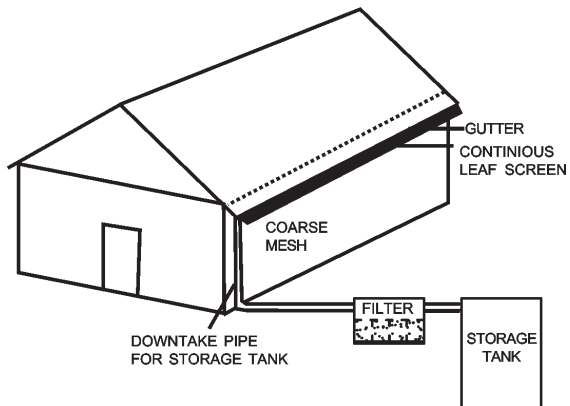

**Fig. 2.5 Leaf screen**

### **2.2.3 Gutter**

Gutter is required to be used for collecting water from sloping roof and to divert it to downspout. These are the channels all around the edge of a sloping roof to collect and transport rain water to the storage tank. Gutters can be of semi-circular, rectangular or trapezoidal shape. Gutters must be properly sized, sloped and installed in order to maximize the quantity of harvested rain. Gutter can be made using any of the following materials:

- (a) Galvanized iron sheet
- (b) Aluminum sheet
- (c) Semi-circular gutters of PVC material which can be readily prepared by cutting these pipes into two equal semi-circular channels
- (d) Bamboo or betel trunks cut vertically in half (for low cost housing projects )

The size of the gutter should be according to the flow during the highest intensity rain. The capacity of the gutters should be 10 to 15% higher. The gutters should be supported properly so that they do not sag or fall off when loaded with water. The connection of gutters and down spouts should be done very carefully to avoid any leakage of water and to maximize the yield. For jointing of gutters, the lead based materials should not be used, as it will affect the quality of water.

### **2.2.4 Down spout / conduit**

The rain water collected on the roof top is transported down to storage facility through down spouts / conduits. Conduits can be of any material like PVC, GI or cast iron. The conduits should be free of lead and any other treatment which could contaminate the water. Table 2.1 gives an idea about the diameter of pipe required for draining out rain water based on rainfall intensity and roof area.

**Table 2.1 Size of downspout pipe**

Diameter of pipe (in mm)	Average rate of rain fall (in mm/hr)					
	50	75	100	125	150	200
50	13.4	8.9	6.6	5.3	4.4	3.3
65	24.1	16.0	12.0	9.6	8.0	6.0
75	40.8	27.0	20.4	16.3	13.6	10.2
100	85.4	57.0	42.7	34.2	28.5	21.3
125	-	-	80.5	64.3	53.5	40.0
150	-	-	-	-	83.6	62.7

Source: National Building Code

### **2.2.5 First flushing device**

Roof washing or the collection and disposal of the first flush of water from a roof, is very important if the collected rain water is to be used directly for human consumption. All the debris, dirt and other contaminants especially bird dropping etc. accumulated on the roof during dry season are washed by the first rain and if this water will enter into storage tank or recharge system it will contaminate the water. Therefore, to avoid this contamination a first flush system is incorporated in the roof top rain water harvesting system. The first flushing device, dispose off the first spell of rain water so that it does not enter the system. If the roof is of sloping type, then the simplest system consists of a pipe and a gutter down spout located ahead of the down spout from the gutter to the storage tank. (Fig. 2.6)

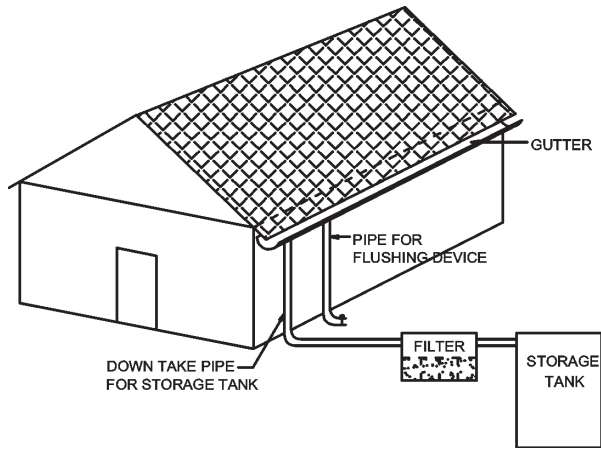

**Fig. 2.6 First flushing device**

The pipe is usually 6 or 8 inch PVC pipe which has a valve and cleanout at the bottom, most of these devices extend from the gutter to the ground where they are supported. The gutter down spout and top of the pipe are fitted and sealed so that water will not flow out of the top. Once the pipe has filled, the rest of the water flows to the downspout connected to storage tank.

The alternate scheme for sloping roof is shown in Fig. 2.7. This involves a very simple device which is required to be operated manually. In down take pipe at the bottom one plug/ valve is provided. When the rainy season start, this plug should be removed, and initial collection of roof top water should be allowed to drain. After 15 – 20 minutes, plug / valve should be closed so that collected rain water can be diverted to storage tank.

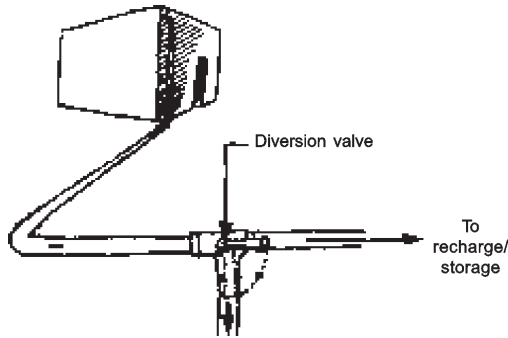
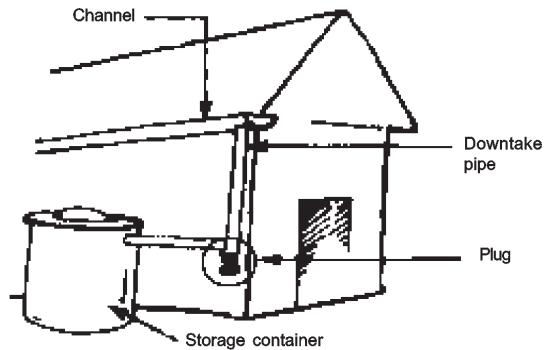

**Fig. 2.7 First flushing device.**

### **2.2.6 Filter**

If the collected water from roof top is to be used for human consumption directly, a filter unit is required to be installed in RWH system before storage tank. The filter is used to remove suspended pollutants from rain water collected over roof. The filter unit is basically a chamber filled with filtering media such as fiber, coarse sand and gravel layers to remove debris and dirt from water before it enters the storage tank. The filter unit should

be placed after first flush device but before storage tank. There are various type of filters which have been developed all over the country. The type and selection of filters is governed by the final use of harvested rain water and economy. Depending upon the filtering media used and its arrangements, various types of filters available are described below.

### 2.2.6.1 Sand filter

In the sand filters, the main filtering media is commonly available sand sandwiched between two layers of gravels. The filter can be constructed in a galvanized iron or ferro cement tank. This is a simple type of filter which is easy to construct and maintain. The sand fillers are very effective in removing turbidity, colour and microorganism. In a simple sand filter that can be constructed domestically, filter media are placed as shown in Fig. 2.8.

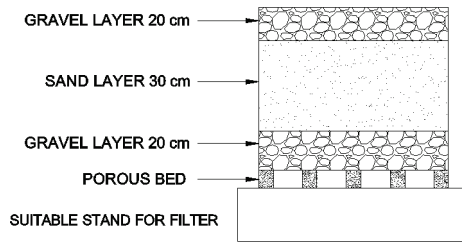

**Fig. 2.8 Sand filter**

### 2.2.6.2 Charcoal water filter

This is almost similar to sand filter except that a 10-15 cm thick charcoal layer placed above the sand layer. Charcoal layer inside the filter result into better filtration and purification of water. The commonly used charcoal water filter is shown in Fig. 2.9.

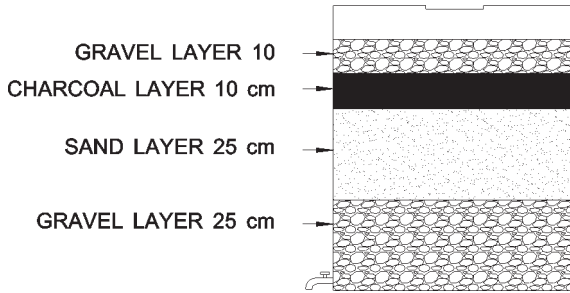

**Fig. 2.9 Charcoal water filter**

### **2.2.6.3 Dewas filter**

This filter was developed by officials of Rural Engineering Services of Dewas. In Dewas, the main source of water supply is wells which are used to extract ground water for supply of water. Because of regular extraction of ground water, the water table is going down rapidly. To recharge the ground water, all the water collected from the roof top is collected and passed through a filter system called the Dewas filter( Fig. 2.10). The filtered water is finally put into service tube well for recharging the well.

The filter consists of a PVC pipe 140mm in diameter and 1.2m long. There are three chambers. The first purification chamber has pebbles of size varying between 2-6 mm, the second chamber has slightly larger pebbles between 6 to 12 mm and the third chamber has largest 12 – 20mm pebbles. There is a mesh on the out flow side, through which clean water flows out after passing through the three chambers. This is one of the most popular filter type being used in RWH systems.



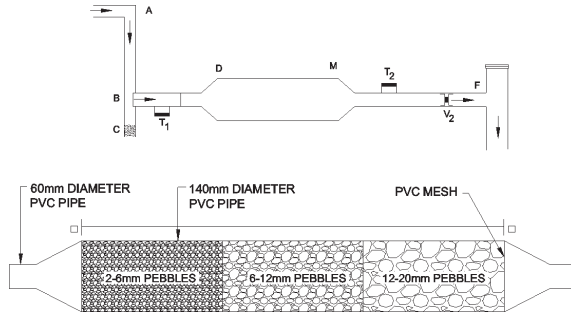

**Fig. 2.10 Dewas filter**

#### 2.2.6.4 Varun

This filter has been developed by Shri S. Viswanath, a Bangalore based water harvesting expert. “Varun” is made from 90 lit. High Density Poly Ethylene (HDPE) drum. The lid is turned over and holes are punched in it. ( Fig. 2.11) The punched lid acts as a sieve which keeps out large leaves, twigs etc. Rain water coming out of the lid sieve then passes through three layers of sponge and 150mm thick layer of coarse sand. Because of sponge layers, the cleaning of filter becomes very easy. The first layer of sponge can be removed and cleaned very easily in a bucket of water. Because of the layers of sponge, the sand layer does not get contaminated and does not require any back washing / cleaning. This filter can handle about 50mm per hour intensity rain fall from a 50 sqm roof area.

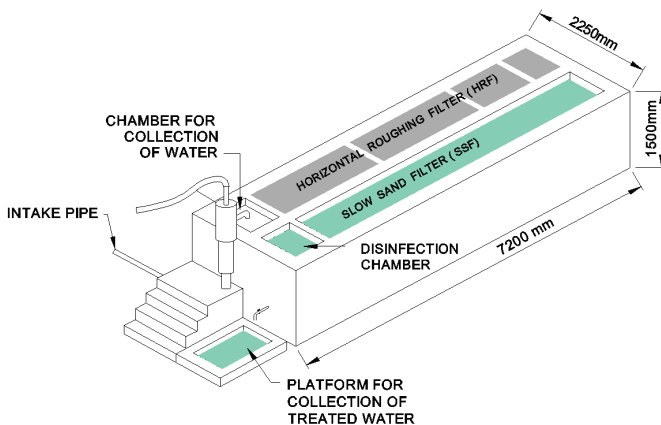

**Fig. 2.11 Varun**

### 2.2.6.5 Horizontal roughening filter and slow sand filter

This is one of the most effective filter for purification of water being used in coastal areas of Orissa. The horizontal roughening filter (HRF) acts as a physical filter and is applied to retain solid matter, while slow sand filter (SSF) is primarily a biological filter, used to kill microbes in the water. The water is first passed through the HRF and then through SSF.

The HRF usually consists of filter material like gravel and coarse sand that successively decrease in size from 25mm to 4mm. The bulk of solids in the incoming water is separated by this coarse filter media or HRF. The filter channel consists of three uniform compartments, the first packed with broken bricks, the second with coarse sand followed by fine sand in the third compartment. At every outlet and inlet point of the channel, fine graded mesh is implanted to prevent entry of finer material into the sump. The length of each channel varies accordingly to the nature of the site selected for the sump (Fig. 2.12).



**Fig. 2.12 Horizontal roughening filter and slow sand filter**

The slow sand filter (SSF) consists of fine sand in a channel of size one sqm in cross section and eight metre in length, laid across the tank embankment. The water after passing through SSF is stored in a sump. From this sump water can be supplied through pipe line or can be extracted through hand pump.

Wherever the roof top area is very large, the filters of high capacity are designed to take care of excess flow. For large roof tops, a system is designed with three concentric circular chambers in which outer chamber is filled with sand, the middle one with coarse aggregate and the inner most layer with pebbles (Fig. 2.13). Since the sand is provided in outer chamber, the area of filtration is increased for sand, in comparison to coarse aggregate and pebbles. Rain water reaches the center core and is collected in the sump where it is treated with few tablets of chlorine and is made ready for consumption.

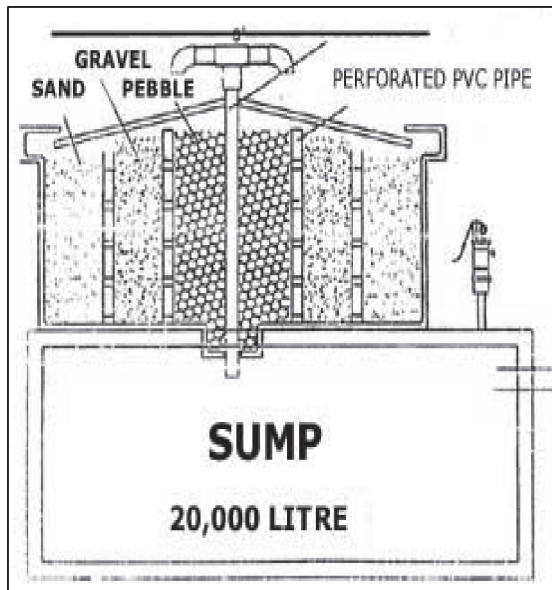

**Fig. 2.13 Filter for large roof top**

### 2.2.6.6 Rain water purification center

This filter has been developed by three Netherlands based companies for conversion of rain water to drinking water and is popularly known as Rain PC. Rain PC is made of ultra violet resistant poly-ethylene housing and cover, stainless steel rods and bolts, a nickel-brass valve and an adapter for maintaining constant volume (Fig. 2.14).

This filter can effectively remove E-coli and other bacteria from water using Xenotex-A and active carbon cartridges along with ultra membrane filtration modules. This filter is easy to operate and maintain and needs no power. This operates at low gravity pressure and maintains nearly constant volume irrespective of water pressure. The system is capable of providing a constant flow of about 40 lit. of rain water per hour. The Xenotex- A and activated carbon cartridges processes up to 20,000 liters of water and can be regenerated up to 10 times.

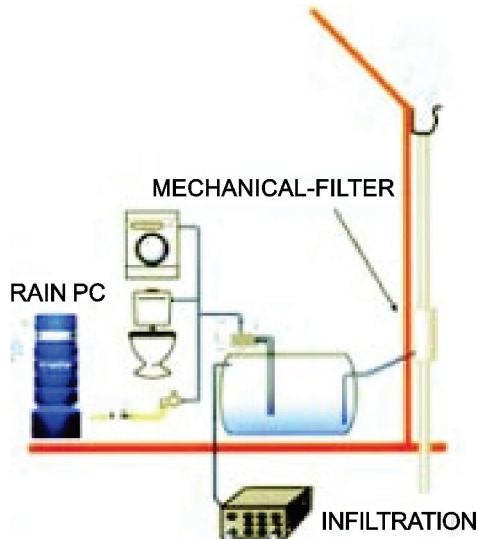
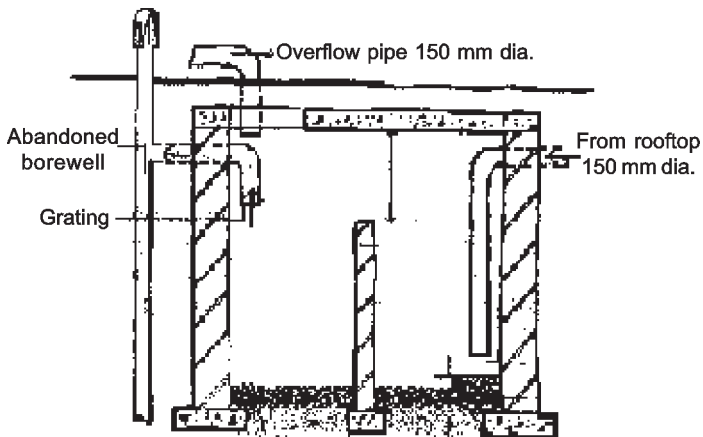

Fig. 2.14 Rain water purification center

## 2.2.7 Settlement tank

If the collected rain water from roof top / ground is used to recharge ground water reserve, it should be passed through a desilting pit/ settlement tank before entering the aquifer. The settlement tank facilitates the settling down of suspended material i.e. silt and other floating impurities before the water recharge the aquifer. The settlement tank should have inlet, outlet and overflow device. Any container with adequate capacity of storage can be used as settlement tank. It can be either underground or over ground.

The settlement tank acts like a buffer in the system. In case of excess rainfall, the rate of recharge, especially of borewells, may not match the rate of rainfall. In such situations, the desilting chamber holds the excess amount of rain water, till it is soaked by recharge structures. The settlement tank can be prefabricated PVC or Ferro-cement tanks, masonry and concrete tanks (Fig. 2.15). In case of underground settlement tank, the bottom can be unpaved surface so that water can percolate through soil.



**Fig. 2.15 Settlement tank**

For designing the optimum capacity of the settlement tank,

the following parameters need to be considered –

- (a) Size of the catchment
- (b) Intensity of rain fall
- (c) Rate of recharge

The capacity of the tank should be enough to retain the runoff occurring from conditions of peak rainfall intensity. The rate of recharge in comparison to runoff is a critical factor. The capacity of recharge tank is designed to retain runoff from at least 15 minutes of rainfall of peak intensity.

For example, for Delhi peak hourly rainfall is 90mm (based on 25 year frequency) and 15 minutes peak rainfall is 22.5 mm say 25mm.

$$\begin{aligned}\text{Area of roof top catchment (A)} &= 100 \text{ sqm.} \\ \text{Peak rain fall in 15 min (r)} &= 25\text{mm (0.025m)} \\ \text{Runoff coefficient (C)} &= 0.85 \\ \text{Then, capacity of settlement tank} &= A \times r \times C \\ &= 100 \times 0.025 \times 0.85 \\ &= 2.125 \text{ cum} \\ &\text{or 2,125 liters}\end{aligned}$$

### **2.2.8 Storage tank**

Whenever the rain water collected from roof top is used directly for various purposes, storage tank is required. The storage tank can be cylindrical, rectangular or square in shape. The material of construction can be RCC, ferrocement, masonry, PVC or metal sheets. Depending upon the availability of space, the storage tank can be above ground, partially underground or fully underground. The design of storage tank is dependent on many factors which are listed below:

- (a) Number of persons in the household – The greater the number of persons, more will be requirement of water.

- (b) Per capita requirement – varies from household to household, based on standard of living. The requirement also varies with season. In summer the requirement is more in comparison to winter. Similarly, the per capita requirement is more in urban areas in comparison to rural areas.
- (c) Average annual rainfall.
- (d) Rainfall pattern – It has a significant impact on capacity of storage tank. If the rainfall is uniformly spread throughout the year, the requirement of storage capacity will be less. But if the rainfall is concentrated to a limited period in a year, the storage tanks of higher capacity will be required.
- (e) Type and size of catchment – Depending upon the type of roofing material, the runoff coefficient varies which affect the effective yield from a catchment area. The size of the catchment also has a bearing on tank size. The more the catchment area, larger the size of storage tank.

The design of the storage tank, can be done using following three approaches:

- (a) Matching the capacity of the tank to the area of the roof.
- (b) Matching the capacity of the tank to the quantity of water required by its users.
- (c) Choosing a tank size that is appropriate in terms of costs, resources and construction methods.

### **2.2.8.1 Matching the capacity of the tank with the area of the roof**

In this approach, storage capacity of the tank is determined, based on the actual catchment area and total rain water harvesting potential. All the water collected from roof top is stored in storage tank and storage capacity is calculated based on the consumption pattern and rainfall pattern.

Illustration – Suppose the storage tank has to be designed for 200 sqm roof area in Chennai area where average annual

rainfall is 1290mm. The runoff coefficient for roof top is 0.85, so for every 1mm rainfall, the quantity of water which can be harvested is  $200 \times 0.001 \times 0.85 = 0.170\text{m}^3$  or 170 liters.

The monthly consumption of water is 20,000 liters. Table 2.2 given below illustrates the method of calculation of required storage capacity of the tank.

**Table 2.2 Calculation of capacity of storage tank**

Month	Monthly Rain fall in mm	Rain fall Harvested in liters	Cumulative rain fall harvested	Monthly Demand in liters	Cumulative	Difference between (4) & (6)
(1)	(2)	(3)	(4)	(5)	(6)	(7)
July	98	16660	16660	20000	20000	-3340
Aug	136	23120	39780	20000	40000	-220
Sept.	122	20740	60520	20000	60000	520
Oct.	282	47940	108460	20000	80000	28460
Nov.	354	60180	168640	20000	100000	68640
Dec.	141	23970	192610	20000	120000	72610
Jan.	30	5100	197710	20000	140000	47710
Feb.	8	1360	199070	20000	160000	39070
Mar.	5	850	199920	20000	180000	39920
Apr.	15	2550	202470	20000	200000	2470
May	38	6460	208930	20000	220000	-11070
June	61	10370	219300	20000	240000	20700

Total annual rain fall: 1290mm

From the above table, it can be seen that difference between cumulative rainfall harvested and cumulative demand is maximum in the month of December at 72610 liters. So the capacity of storage tank should be 72610 liters, say 73000 liters.



### **2.2.8.2 Matching the capacity of the tank with the quantity of water required by its users**

Suppose the system has to be designed for meeting drinking water requirement of a 4 member family living in the building with a roof top area of 200 sqm. The average annual rainfall in the Chennai region is 1290 mm. Daily drinking water requirement is 10 liters per person.

$$\begin{aligned} \text{If area of catchment (A)} &= 200 \text{ sq.m.} \\ \text{average annual rainfall (R)} &= 1290 \text{ mm (1.290 m)} \\ \text{and runoff coefficient (C)} &= 0.85 \\ \text{Then, annual rain water} & \\ \text{harvesting potential} &= 200 \times 1.290 \times 0.85 \\ &= 219.30 \text{ cum or 2,19,300 liters} \end{aligned}$$

The tank capacity is determined based on the dry period i.e. the period between the two consecutive rainy seasons. For example, with a monsoon extending over 5 months, the dry season is of 215 days.

Drinking water requirement for the family during dry season =  $215 \times 4 \times 10 = 8600$  liters. After keeping some factor of safety, the tank should have 20 percent more capacity than required above, i.e. 10,320 liters.

### **2.2.8.3 Choosing a tank size, appropriate in terms of costs, resources and construction methods**

In practice, the costs, resources and construction methods tend to limit the storage tank to smaller capacity in comparison to requirement as per approach 1 & 2. Depending upon the budget and space available, the construction of storage tank is done so that at least for some period dependence on municipal sources / water tankers can be minimized.



## CHAPTER - 3

### RECHARGING SUBSURFACE AQUIFERS

#### 3.1 Methods of Recharging Subsurface Aquifers

The various methods of recharging subsurface aquifers are:

1. Through recharge pit.
2. Recharge through abandoned hand pump.
3. Recharge through abandoned dug well/open well.
4. Through recharge trench.
5. Recharge through shaft.
6. Recharge trench with bore.

##### 3.1.1 Through recharge pit

This method is suitable where permeable strata is available at shallow depth. It is adopted for buildings having roof area up to 100 sqm. Recharge pit of any shape is constructed generally 1-2 m wide and 2-3 m deep. The pit is filled with boulders, gravel and sand for filtration of rain water. Water entering in to RWH structure should be silt free. Top layer of sand of filter should be cleaned periodically for better ingress of rain water in to the sub soil. Details are shown in Fig. 3.1.

##### 3.1.2 Recharge through abandoned hand pump

In this method, an abandoned hand pump is used as recharging structure. It is suitable for building having roof top area up to 150 sqm . Roof top rain water is fed to the hand pump through 100 mm dia. pipe as shown in Fig. 3.2. Water fed in the Rain water harvesting structure should be silt free. Water from first rain should be diverted to drain through suitable arrangement. If water is not clear then filter should be provided.

##### 3.1.3 Recharge through abandoned dug well / open well

In this method, a dry / unused dug well can be used as a

recharge structure. It is suitable for buildings having a roof top area more than 100 sqm . Recharge water is guided through a pipe of 100 mm to the bottom of the well as shown in Fig. 3.3. Well cleaning and desilting is imperative before using it. Recharge water guided should be silt free, otherwise filter should be provided as shown in Fig. 3.3. Well should be cleaned periodically and chlorinated to control bacteriological contamination.

### **3.1.4 Through recharge trench**

This method is used where permeable strata is available at shallow depth. It is suitable for buildings having roof top area between 200 & 300 sqm. In this method, trench of 0.5-1.0 m wide, 1-1.5 m deep and of adequate length depending upon roof top area and soil/subsoil characteristics should be constructed and filled with boulders, gravel and sand as shown in Fig. 3.4. Cleaning of filter media should be done periodically.

### **3.1.5 Recharge through shafts**

This method is suitable where shallow aquifer is located below clayey surface. It is used for buildings having roof top area between 2000 & 5000 sqm. Recharge shaft of diameter 0.5-3 m and 10-15 m deep is excavated mechanically. The shaft should end in impermeable strata. The shaft should be filled with boulders, gravel and sand for filtration of recharge water. Top sand layer should be cleaned periodically. Recharge shaft should be constructed 10-15 m away from the buildings for the safety of the buildings. The details are given in Fig. 3.5.

### **3.1.6 Recharge trench with bore**

This method is used where sub-soil is impervious and large quantity of roof water/ surface run off is available. In this, trench is made 1.5-3 m wide and 10-30 m length depending upon water availability. Wells of 150-300 mm dia. and 3-5 m deep (below pervious layer) are constructed in the trench. Numbers of wells to be dug are decided in accordance to water availability and rate of ingress. Trench is filled with filtration media as shown in Fig. 3.6. A suitable silt chamber is also inserted with grating for water diverting arrangements as shown in the figure.

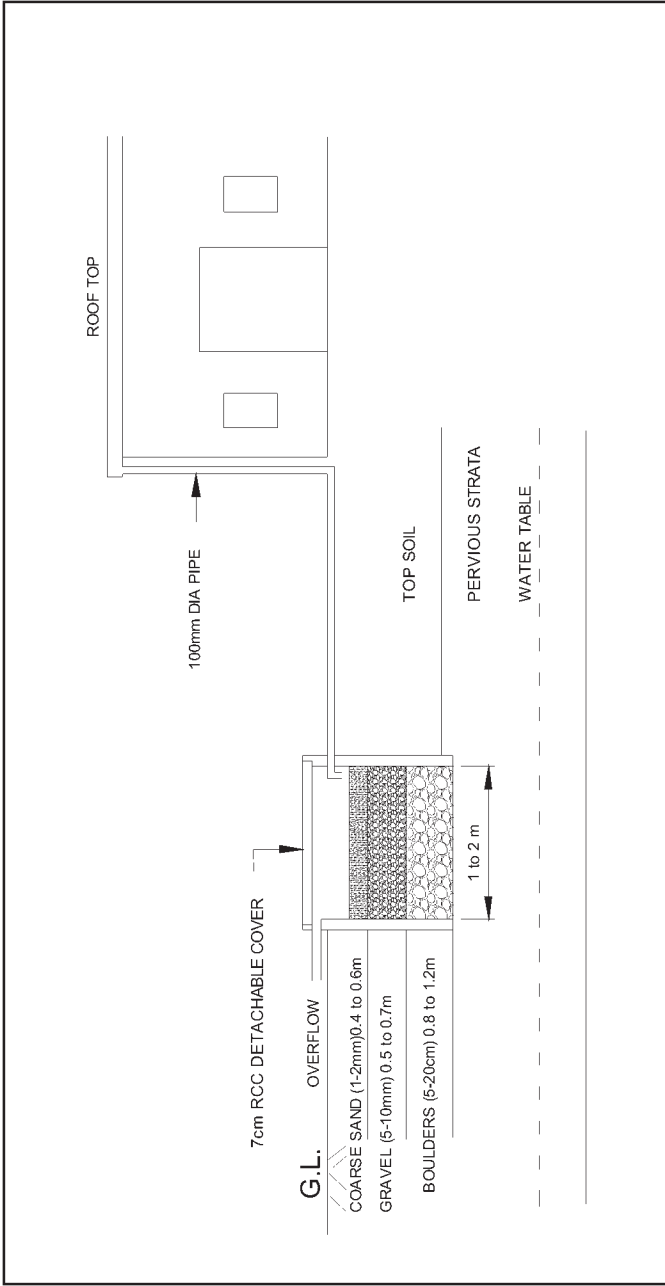

**Fig. 3.1 Through recharge pit**

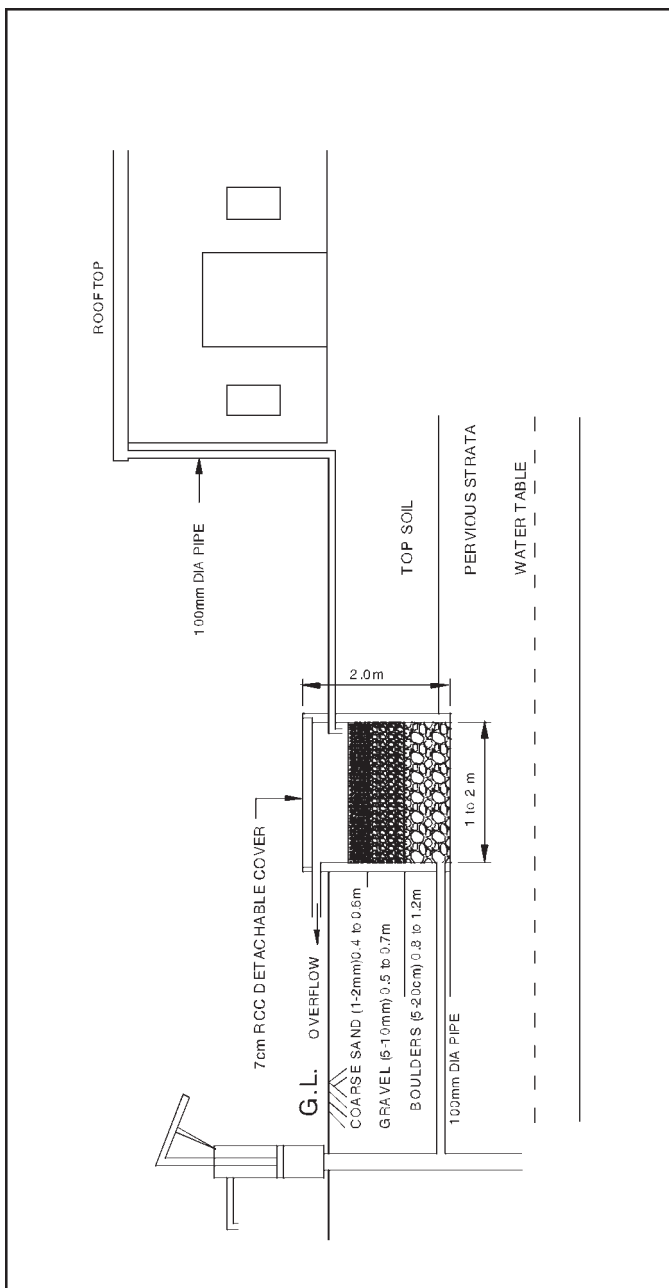

**Fig. 3.2 Recharge through abandoned hand pump**

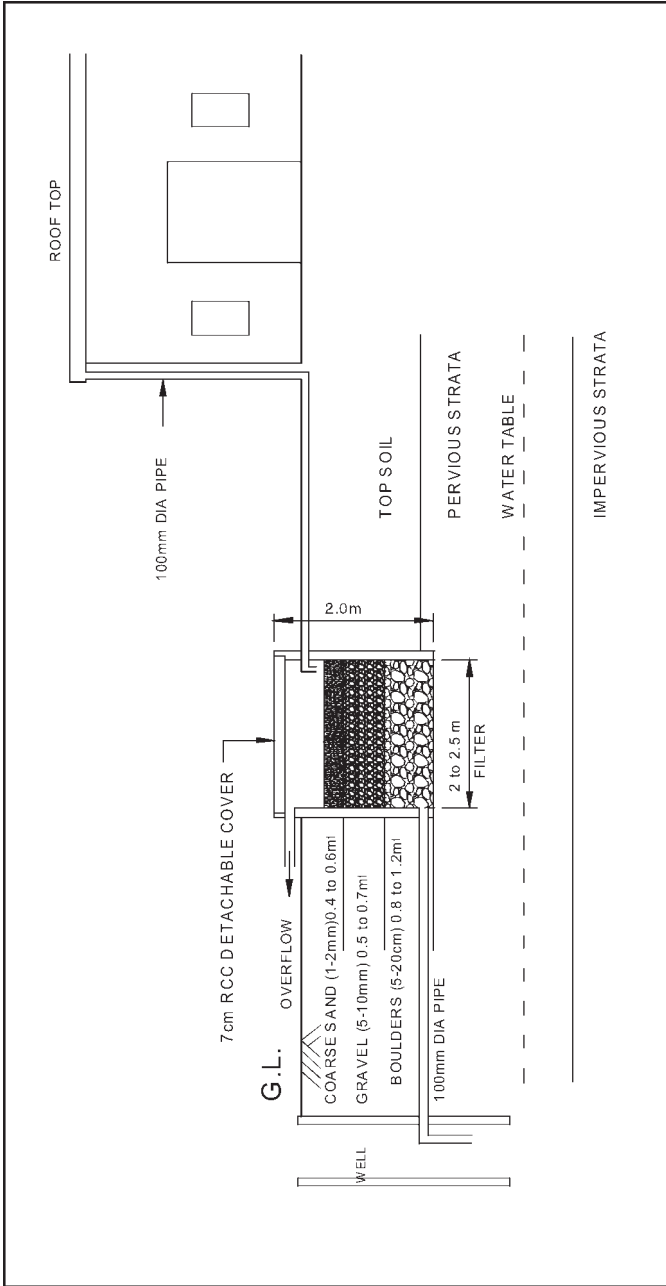

**Fig. 3.3 Recharge through abandoned open well**

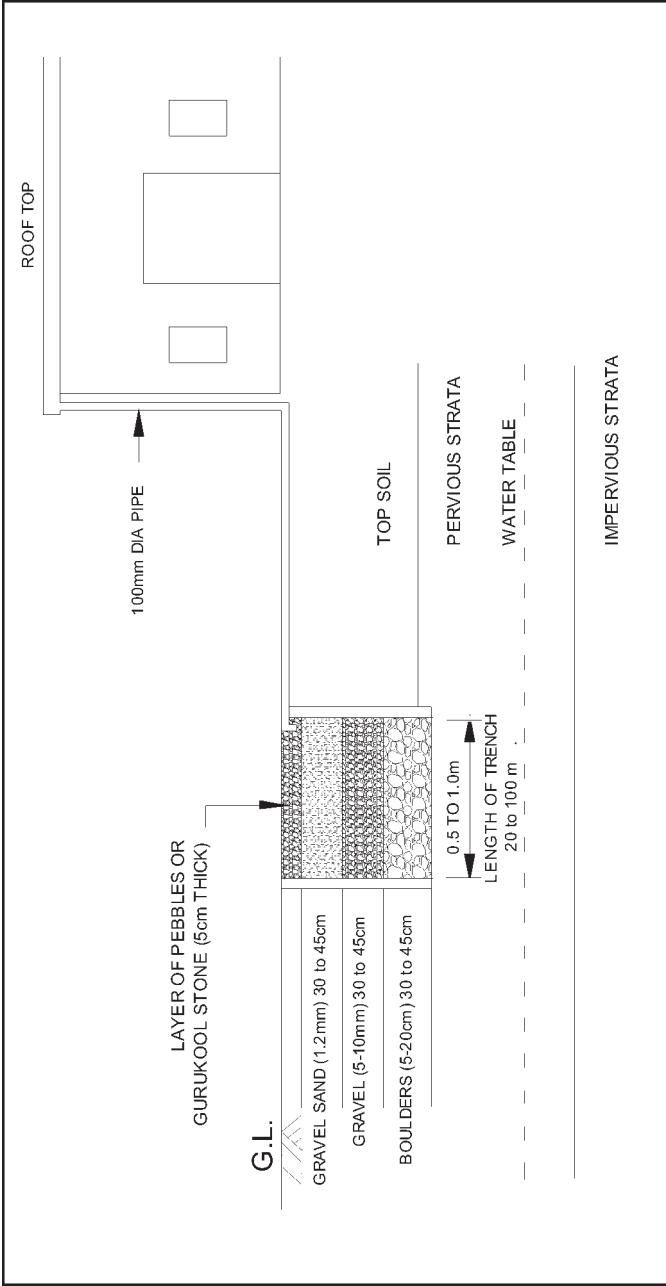

**Fig. 3.4 Through recharge trench**

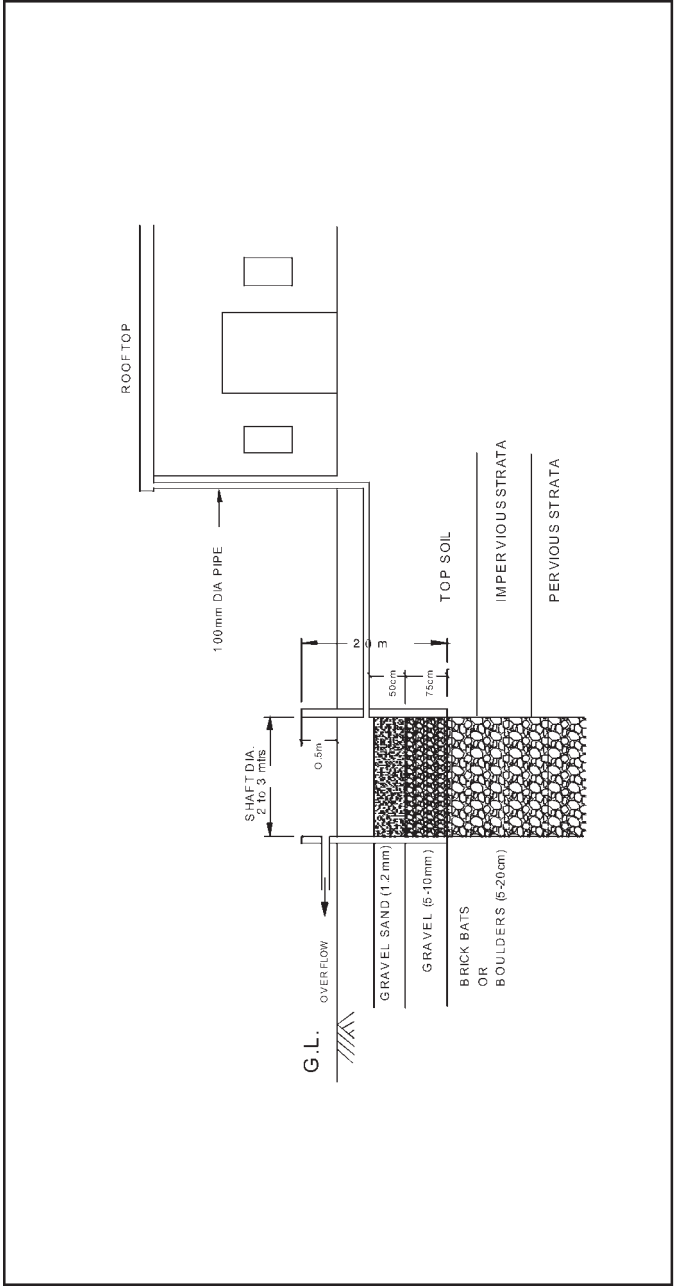
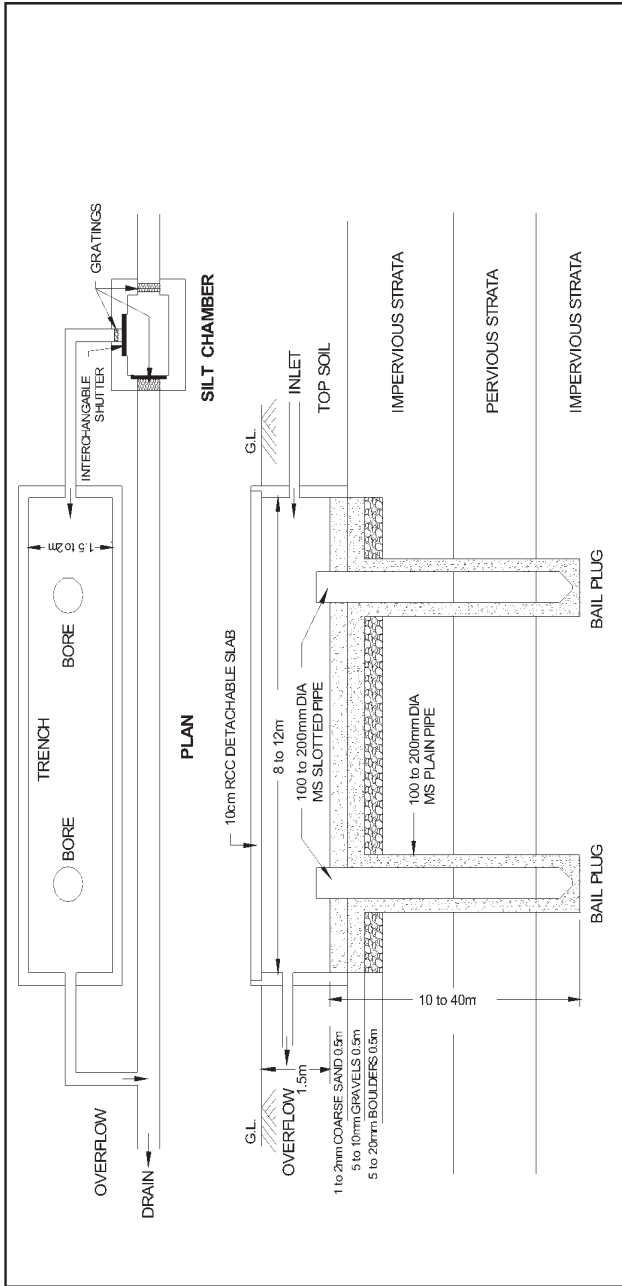

Fig. 3.5 Recharge through shaft





**Fig. 3.6 Recharge trench with bore**

# CHAPTER - 4

## CASE STUDY

### 4.1 Introduction

The various method of rain water harvesting explained in previous chapters are equally applicable for the single building or structure which is having built up area. Since the principals of rain water harvesting are universal, the same can be applied for rain water harvesting in big colonies/establishment with some minor modifications. The basic components of any rain water harvesting system remain the same but the number and size may vary depending upon the catchments area. If the rain water harvesting has to be implemented in a large area i.e. an office complex or big residential complex, the area can be subdivided into smaller parts. The runoff from each smaller part can be harvested through recharge structures constructed nearby while the runoff from open areas can be canalized through storm water drains into recharge structures. Fig.4.1 given below indicates one such type of scheme.

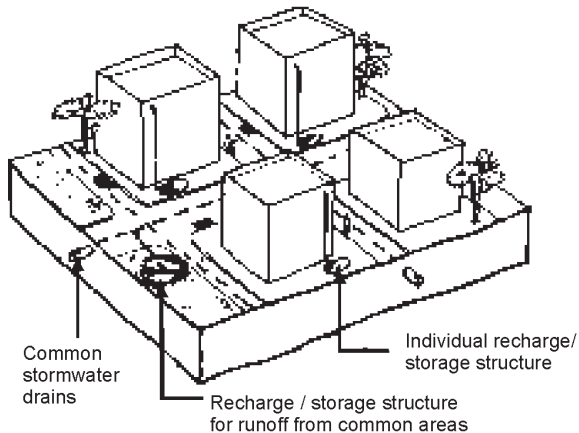

**Fig. 4.1 Rain water harvesting in a large area**

## 4.2 Rain Water Harvesting at IRICEN Hostel

The Indian Railways Institute of Civil Engineering (IRICEN), Pune is having a 104 rooms hostel at Koregaon Park. The total area of the hostel building is approx. 1162.5 sqm and open area in the hostel is approx. 900 sqm. In first phase, the rain water harvesting has been implemented in left wing of the hostel, covering a roof top area of 465 sqm and open area of 788 sqm. For rain water harvesting, a deep bore well of 32m. depth and 150mm dia. has been bored.

The annual rainfall (R) in Pune is approx. 700mm. Considering a roof top area (A) of 465 sqm and runoff coefficient (C) of 0.85, the rain water harvesting potential from roof top is

$$\begin{aligned} &= A \times R \times C \\ &= 465 \times 0.700 \times 0.85 \\ &= 276.675 \text{ cum or } 2,76,675 \text{ liters} \end{aligned}$$

The open area from which runoff is to be collected is approx. 788 sqm. Considering a runoff coefficient (C) of 0.55 for open areas, the rain water harvesting potential from open area is

$$\begin{aligned} &= A \times R \times C \\ &= 788 \times 0.700 \times 0.55 \\ &= 303.38 \text{ cu.m. or } 3,03,380 \text{ liters} \end{aligned}$$

Total rain water harvesting potential annually is 5,80,055 liters from the roof top and open area. The scheme for rain water harvesting implemented at IRICEN is shown in fig 4.2.

The runoff from roof top is collected through down take pipes / conduits of 100mm dia. After collection through conduits, the collected water is channelised through a network of drains (underground) having 250/150mm dia. RCC pipes to a settlement tank cum filter. Similarly the runoff from open area is also collected through series of chambers constructed along the drains and channelised to settlement tank cum filter. The details of settlement tank cum filter are shown in Fig. 4.3.

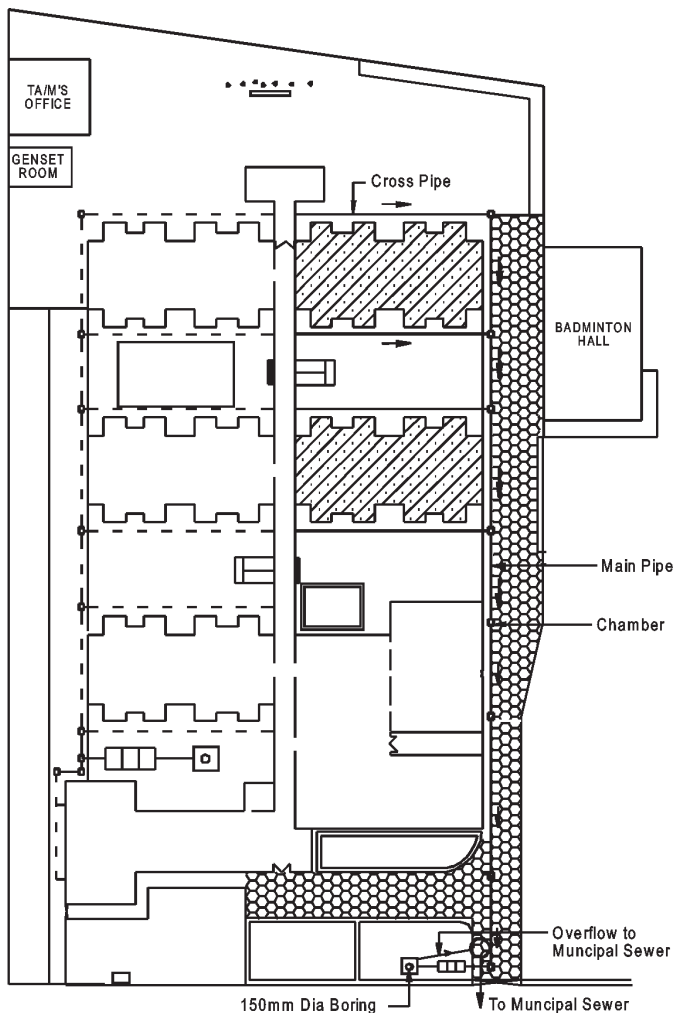

- |  |   |
|--|---|
| <p>1. Drain pipe dia</p> <p style="margin-left: 20px;">a. Main pipe dia 250mm</p> <p style="margin-left: 20px;">b. Cross pipe dia 150mm</p> <p>2. Spacing of chambers - average 11 m,<br/>provided with iron grill top cover</p> | <p>3. Dia of boring 150mm</p> <p>4. Depth of boring 32 m</p> <p>5. Roof top area - 465 sq.m. </p> <p>6. Open area - 788 sq. m. </p> |
|--|---|

**Fig. 4.2 Rain water harvesting at IRICEN hostel**

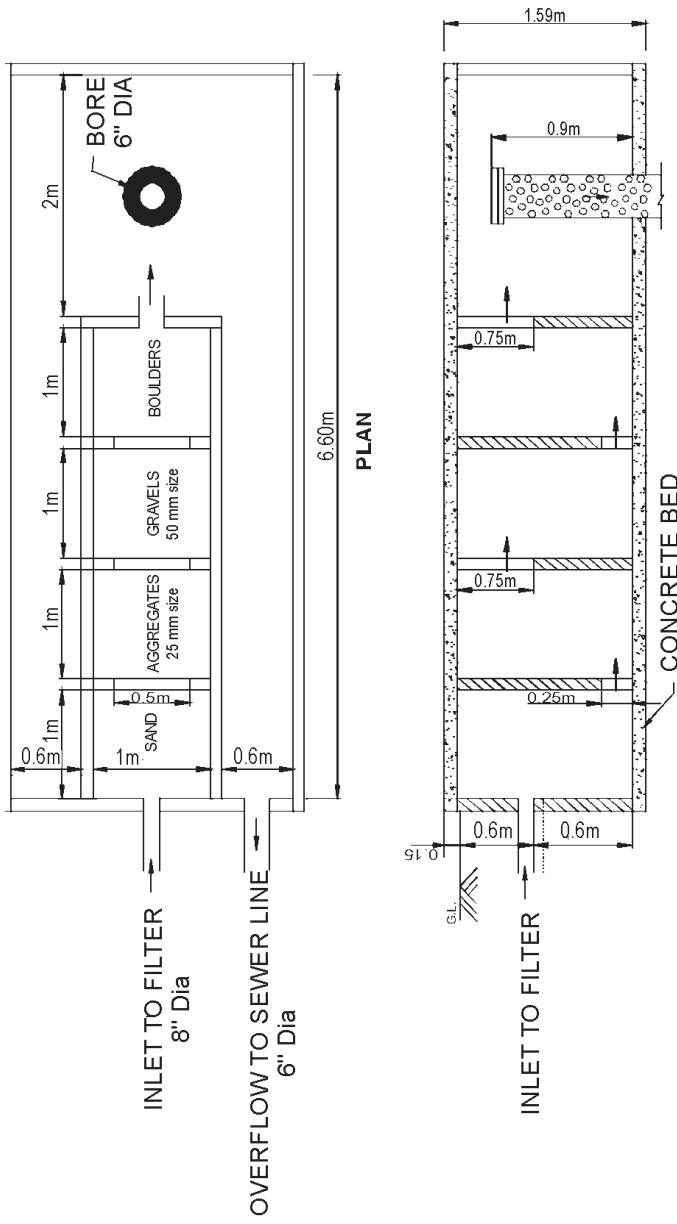

Fig. 4.3 Details of settlement tank / filter for Rain Water Harvesting

The capacity of filter cum settlement tank is 8400 liters, which is sufficient to retain runoff from at least 15 minutes rainfall of peak intensity. After passing through the filter media, the filtered water enters into the 150mm dia 32m deep borewell, bored specifically for this purpose i.e. for recharging ground water aquifer. The overflow from settlement tank/filter enters into the municipal sewer through the connection provided. The total cost of implementation of the project in IRICEN hostel was approximately Rs. 55,000 and the system was implemented in January 2006.



## CHAPTER - 5

### QUALITY OF WATER

The rain water is one of purest form of water and does not contain suspended / dissolved impurities. However when this water is collected through rain water harvesting, it gets contaminated because of contact with roof surface/ground and some of the impurities get mixed in it. These impurities are required to be removed before collecting the harvested rain water in storage tank or diverting it or recharging of ground water aquifers.

Following precautions should be taken to ensure quality of water:

1. Roof over which water falls, should be cleaned before rain fall.
2. The suitable type of first flushing device to be installed and initial 10 to 15 minutes of runoff should be diverted.
3. The water collected from roof top only, should be stored in storage tank for direct use.
4. The runoff from surface/ground should be preferably be used for recharging ground water aquifers after proper filtration.
5. The rain water collected from roof top should pass through suitable type of filter and only then it should be stored in storage tank / used for recharging ground water aquifers.

The harvested rain water may contain some toxic substances which may affect our health. The water collected from roof top after filtration can be used directly for lawn watering, washing etc. But if this water has to be used directly for drinking purpose, then quality of water must be ascertained before use.

The water used for drinking should comply with the provisions of IS-10500:1991 i.e. Indian Standard "DRINKING WATER – SPECIFICATION (First Revision)". The important test characteristics for drinking water as given in Table 1 of IS-10500:1991 are reproduced in Table 5.1 for ready reference.

Table 5.1 Important test characteristics for drinking water

S	Substance Characteristics	Requirement (Desirable Limit)	Undesirable Effect Outside the Desirable Limit	Permissible Limit in the Absence of Alternate Source	Method of Test (Ref. to IS)	Remarks
1	2	3	4	5	6	7
<b>Essential Characteristics</b>						
i	Colour, Hazen units, Max.	5	Above 5, consumer acceptance decreases	25	3025(Part-4): 1983	Extended to 25 only if toxic substances are not suspected in absence of alternate sources.
ii	Odour	Unobjectionable	-	-	3025 (Part-5): 1983	a) Test cold and when heated b) Test at several dilutions
iii	Taste	Agreeable	-	-	3025 (Part 7&8):1984	Test to be conducted only after safety has been established.
iv	Turbidity NTU, Max.	5	Above 5, consumer acceptance decreases.	10	3025 (Part 10): 1984	
v	pH Value	6.5 to 8.5	Beyond this range the water will affect the mucous membrane and/or water supply system	No relaxation	3025 (Part 11): 1984	



S N	Substance Characteristics	Requirement (Desirable Limit)	Undesirable Effect Outside the Desirable Limit	Permissible Limit in the Absence of Alternate Source	Method of Test (Ref. to IS)	Remarks
1	2	3	4	5	6	7
vi	Total Hardness (as CaCO <sub>3</sub> ) mg/l, Max.	300	Encrustation in water supply structure and adverse effects on domestic use.	600	3025 (Part 21): 1983	
vii	Iron (as Fe) mg/l, Max.	0.3	Beyond this limit taste/ appearance are affected , has adverse effect on domestic uses and water supply structures, and promotes iron bacteria.	1.0	32 of 3025 : 1964	
viii	Chloride (as Cl) mg/l, Max.0.3	250	Beyond this limit, test, corrosion and palatability are affected.	1000	3025 (Part 32): 1988	
ix	Residual free chlorine mg/l, Min	0.2	-	-	3025 (Part 26)1986	To be applicable only when water is chlorinated. Tested at consumer end. When protection is required, it should be Min 0.5mg/l

S N	Substance Characteristics	Requirement (Desirable Limit)	Undesirable Effect Outside the Desirable Limit	Permissible Limit in the Absence of Alternate Source	Method of Test (Ref. to IS)	Remarks
1	2	3	4	5	6	7
x	Fluoride (as F) mg/l, Max.	1.0	Fluoride may be kept as low as possible. High fluoride may cause fluorosis	1.5	23 of 3025 1964	
<b>Desirable Characteristics</b>						
xi	Dissolved solid mg/l, Max.	500	Beyond this palatability decreases and may cause gastro intestinal irritation	2000	3025 (Part 16) 1984	
xii	Calcium (as Ca) mg/l, Max.	75	Encrustation in water supply structure and adverse effect on domestic use	200	3025 (Part 40) 1991	
xiii	Magnesium (as Mg) mg/l, Max.	30	Encrustation to water supply structure and adverse effect on domestic use	100	16.33.34 of IS 3025 1964	
xiv	Copper (as Cu) mg/l, Max.	0.05	Astringent taste, will be caused beyond this discoloration and corrosion of pipes, fitting and utensils	1.5	36 of 3025 1964	

<b>S N</b>	<b>Substance Characteristics</b>	<b>Requirement (Desirable Limit)</b>	<b>Undesirable Effect Outside the Desirable Limit</b>	<b>Permissible Limit in the Absence of Alternate Source</b>	<b>Method of Test (Ref. to IS)</b>	<b>Remarks</b>
<b>1</b>	<b>2</b>	<b>3</b>	<b>4</b>	<b>5</b>	<b>6</b>	<b>7</b>
xv	Sulphate (as SO <sub>4</sub> )	200	Beyond this causes gastro intestinal irritation when magnesium or sodium are present.	400 (sec. col. 7)	3025 (Part 24) 1986	May be extended up to 400 provided Magnesium (as Mg) does not exceed 30
xvi	Nitrate (as NO <sub>2</sub> ) Mg/l, Max.	45	Beyond this methaemoglobinemia takes place	No relaxation	3025 (Part 34) 1988	
xvii	Cadmium (as Cd) Mg/l, Max.	0.01	Beyond this, the water becomes toxic	No relaxation	See Note 1	To be tested when pollution is suspected
xviii	Arsenic (as As) Mg/l, Max.	0.01	Beyond this, the water becomes toxic	No relaxation	3025 (Part 37) 1988	To be tested when pollution is suspected
xix	Lead (as Pb) Mg/l, Max.	0.05	Beyond this limit, the water becomes toxic	No relaxation	See Note 1	To be tested when pollution is suspected
xx	Zinc (as Zn) Mg/l, Max.	5	Beyond this limit it can cause astringent taste & an opalescence in water	15	39 of 3925 1964	To be tested when pollution is suspected
xxi	Mineral Oil Mg/l, Max.	0.01	Beyond this limit undesirable taste and odour after chlorination take place	0.03	Gas chromatographic method	To be tested when pollution is suspected

Note-1 : Atomic absorption spectrophotometric method may be used

To test the quality of water, the water samples can be collected and testing can be done in testing laboratories. But as a routine, the quality of water can also be checked with the help of testing kits by the users themselves. In case, water is not potable, treatment of water may be necessary to make it fit for human consumption. For treatment of water, the following measures can be taken at household level.

- (a) Filtration of water should be done using suitable type of filter. The details of various type of filter are given in chapter 2.
- (b) Chemical disinfection can be done by chlorination. Chlorination is done with stabilized bleaching powder, which is a mixture of chlorine and lime. Chlorination can kill all types of bacteria and make water safe for drinking purposes. Approx. 1 gm of bleaching powder is sufficient to treat 200 liters of water otherwise chlorine tablets, which are easily available in the market can be used for disinfection of water. One tablet of 0.5gm is enough to disinfect 20 litres of water.
- (c) Boiling water is one of the effective method of purification. Boiling water for 10 to 20 minutes is enough to remove all biological contaminants.



## References

1. Texas Guide on rain water harvesting
2. "A Water Harvesting Manual for urban areas" issued by Centre For Science and Environment
3. Paper on "Rain Water Harvesting" written by Sri. Kaushal Kishore, Materials Engineer, Roorkee published in CE&CR , May 2004
4. Indian Standard Guidelines for Rain Water Harvesting in hilly areas by roof water collection system" IS 14961:2001
5. Indian Standard " Drinking Water Specifications" IS 10500 : 1991
6. Indian Railway Works Manual 2000
7. [www.rainwaterharvesting.org](http://www.rainwaterharvesting.org)
8. [www.aboutrainwaterharvesting.com](http://www.aboutrainwaterharvesting.com)



---

For suggestions, please write to:  
[mail@iricen.gov.in](mailto:mail@iricen.gov.in)

---

Published by :

**INDIAN RAILWAYS INSTITUTE OF CIVIL ENGINEERING, PUNE**

11-A, South Main Road, Koregaon Park, Pune - 411001.

Design by :

HUMA Adds, Pune.

Printed by :

Kalyani Corporation, Sadashiv Peth, Pune - 30.

Price ₹ 30/-