

# ROOF SYSTEM DESIGN GUIDE

Featuring Trus Joist® TimberStrand® LSL,  
Microllam® LVL, and Parallam® PSL

- Long-Length Rafters with Consistent Strength and Stability
- Engineered Solutions for Complex Roof Systems
- Quality Products that Speed Up Construction
- Promotes Flat Roofs, Crisp Ridge Lines, and Smooth Cathedral Ceilings
- Limited Product Warranty





The products in this guide are readily available through our nationwide network of distributors and dealers. For more information on other applications or other Trus Joist® products, contact your Weyerhaeuser representative.

**Code Evaluations:**  
See ICC-ES ESR-1387

## TABLE OF CONTENTS

General Assumptions	2
Design Properties	3
Ceiling Joist Span Table	3
Rafter Span and Heel Connection Tables	4–7
Hip and Valley Span Tables	8–9
Cut Length Calculation	9
Hip and Valley Reaction Tables	10
Post Allowable Loads	11
Multiple-Member Connections	11
Rafter, Hip, and Valley Allowable Holes	11
Typical Roof System	12
Roof Framing Details	12 – 14
Framing Connectors	14
Design Example	15



Certified Sourcing  
www.sfiprogram.org  
SFI-00008

## Why Choose Trus Joist® Roof Components?

- Long lengths allow more versatile roof design
- Engineered for strength, consistency, and durability
- Backed by limited product warranties

Many of today's homes have complex roof lines, with open vaults and varied slopes that cannot be built using plated trusses. Designs like these require structural components that are strong, long, and straight enough to give you flat planes and crisp ridge lines.

Weyerhaeuser's Trus Joist® roof system components provide the edge you need when framing complex roof designs. Our TimberStrand® LSL, Microllam® LVL, and Parallam® PSL engineered lumber products are peak performers—they're strong, durable, come in long lengths, and work together.

Get an edge on your next roof project with top-quality engineered lumber products from Weyerhaeuser—and let your craftsmanship show for years to come.

## This guide features Trus Joist® roof components in the following sizes:

### TimberStrand® LSL

#### 1.5E TimberStrand® LSL:

Width: 1½"

Depths: 7¼", 9½", and 11⅞"

#### 1.55E TimberStrand® LSL:

Width: 1¾"

Depths: 9½", 11⅞", and 14"

#### 1.3E TimberStrand® LSL:

Width: 1½"

Depth: 5½"

Columns and posts: 2x4 2x6

### Microllam® LVL

#### 2.0E Microllam® LVL:

Width: 1¾"

Depths: 9¼", 11¼", 14", 16", and 18"

### Parallam® PSL

#### 1.8E Parallam® PSL (columns and posts):

3½" x 3½" 3½" x 5¼" 5¼" x 5¼"

This specifier's guide provides information for using Trus Joist® products in the design of a complete roof system. Individual components may be specified using this guide provided that the remaining components are properly sized and connected.

## GENERAL ASSUMPTIONS

- Technical information in this guide is based on the following assumptions:
  - Roof slopes from 4:12 to 12:12.
  - Lateral design and uplift connections by others or per code.
  - Rafter and ceiling joist spacing of 24" on-center, maximum.
  - Fully sheathed roof areas.
  - Proper detailing for ventilation is the responsibility of others.
- Connections are based on NDS®, using a specific gravity of 0.5.
- A code-allowed repetitive member increase of 4% in bending moment has been included.
- 12d (0.128" x 3") nails may be substituted for the 16d (0.131" x 3¼") nails specified throughout this guide.
- Ceiling joists must be properly installed and connected to the heel end of the rafters to resist thrust. Contact Weyerhaeuser if any of the following conditions exist:
  - Ceiling joists are raised above the bearing plate and fastened within the span of the rafter.
  - Raised or cathedral ceiling area exceeds 15% of the total floor area or is located in a room larger than 320 sq. ft. (16' x 20').



**WARNING:** This product can expose you to chemicals including wood dust which are known to the State of California to cause cancer, and methanol, which are known to the State of California to cause birth defects or other reproductive harm. Drilling, sawing, sanding or machining wood products can expose you to wood dust. Avoid inhaling wood dust or use a dust mask or other safeguards for personal protection. For more information go to [www.P65Warnings.ca.gov](http://www.P65Warnings.ca.gov) and [www.P65Warnings.ca.gov/wood](http://www.P65Warnings.ca.gov/wood).

# DESIGN PROPERTIES

## Design Stresses<sup>(1)</sup> (Beam Orientation, 100% Load Duration)

		1.3E TimberStrand® LSL	1.5E TimberStrand® LSL	1.55E TimberStrand® LSL	2.0E Microllam® LVL	1.8E Parallam® PSL
Shear modulus of elasticity	G =	81,250 psi	93,750 psi	96,875 psi	125,000 psi	112,500 psi
Modulus of elasticity <sup>(2)</sup>	E =	1.3 x 10 <sup>6</sup> psi	1.5 x 10 <sup>6</sup> psi	1.55 x 10 <sup>6</sup> psi	2.0 x 10 <sup>6</sup> psi	1.8 x 10 <sup>6</sup> psi
Adjusted modulus of elasticity <sup>(3)</sup>	E <sub>min</sub> =	660,750 psi	762,400 psi	787,815 psi	1,016,535 psi	914,880 psi
Flexural stress <sup>(4)</sup>	F <sub>b</sub> =	1,700 psi	2,250 psi	2,325 psi	2,600 psi	2,400 psi <sup>(10)</sup>
Tension stress <sup>(5)</sup>	F <sub>t</sub> =	1,300 psi	1,815 psi	1,290 psi <sup>(9)</sup>	1,895 psi	1,995 psi
Compression perpendicular to grain <sup>(6)</sup>	F <sub>c⊥</sub> =	710 psi	860 psi	900 psi	750 psi	545 psi <sup>(10)</sup>
Compression parallel to grain	F <sub>c  </sub> =	1,835 psi	2,105 psi	2,170 psi	2,510 psi	2,500 psi
Horizontal shear parallel to grain	F <sub>v</sub> =	425 psi	505 psi	310 psi <sup>(9)</sup>	285 psi	190 psi <sup>(10)</sup>
Equivalent specific gravity <sup>(7)</sup>	SG	0.50 <sup>(8)</sup>	0.50 <sup>(8)</sup>	0.50 <sup>(8)</sup>	0.50	0.50

(1) Unless otherwise noted, adjustment to the design stresses for duration of load are permitted in accordance with the applicable code.

(2) To properly calculate deflections for the full range of typical SCL span and loading applications, bending and shear deflection must be considered. Use the following equation for simple span, uniformly loaded beams:

$$\Delta = \frac{270 wL^4}{Ebd^3} + \frac{28.8 wL^2}{Ebd}$$

Where:  $\Delta$  = deflection (in.)    w = uniform load (plf)  
 L = span (feet)    b = beam thickness (in.)  
 d = beam depth (in.)    E = modulus of elasticity (psi)

For other span and loading conditions, use engineering mechanics to account for both bending and shear deflection or use Forte® WEB software.

(3) Reference modulus of elasticity for beam and column stability calculations, per NDS®.

(4) For 12" depth. For other depths, multiply  $f_b$  by the appropriate factor as follows:

$$\text{— TimberStrand® LSL } \left[ \frac{12}{d} \right]^{0.092} \quad \text{— Microllam® LVL } \left[ \frac{12}{d} \right]^{0.136} \quad \text{— Parallam® PSL } \left[ \frac{12}{d} \right]^{0.111}$$

(5) Referenced tension design values are based on a standard 4 foot length. For lengths longer than 4 foot, multiply  $F_t$  by the following adjustment (where L is length in feet):

$$\text{— TimberStrand® LSL } (4/L)^{0.083} \quad \text{— Parallam® PSL } (4/L)^{0.056} \quad \text{— Microllam® LVL } (4/L)^{0.085}$$

(6)  $F_{c\perp}$  shall not be increased for duration of load.

(7) For lateral connection design only.

(8) Specific gravity of 0.58 may be used for bolts installed perpendicular to face and loaded perpendicular to grain.

(9) Value accounts for large hole capabilities. See **Allowable Holes** on page 11.

(10) Value shown is for plank orientation.

## Allowable Design Properties (100% Load Duration)

### 1½" Rafters, Ceiling Joists, and Hip and Valley Members

Design Property	1.3E TimberStrand® LSL		1.5E TimberStrand® LSL		
	Member Depth		Member Depth		
	5½"	7¼"	9½"	11⅞"	
Moment (ft-lbs)	1,150	2,580	4,320	6,615	
Shear (lbs)	2,340	3,660	4,795	5,995	
Moment of Inertia (in. <sup>4</sup> )	21	48	107	209	
Weight (plf)	2.4	3.3	4.4	5.4	

### 1¾" Hip and Valley Members

Design Property	1.55E TimberStrand® LSL			2.0E Microllam® LVL				
	Member Depth			Member Depth				
	9½"	11⅞"	14"	9¼"	11¼"	14"	16"	18"
Moment (ft-lbs)	5,210	7,975	10,920	5,600	8,070	12,130	15,555	19,375
Shear (lbs)	3,435	4,295	5,065	3,075	3,740	4,655	5,320	5,985
Moment of Inertia (in. <sup>4</sup> )	125	244	400	115	208	400	597	851
Weight (plf)	5.2	6.5	7.7	4.7	5.7	7.1	8.2	9.2

## PRODUCT STORAGE

Protect products from sun and water



**CAUTION:** Wrap is slippery when wet or icy

Align stickers (2x3 or larger) directly over support blocks

Use support blocks (6x6 or larger) at 10' on-center to keep bundles out of mud and water

TimberStrand® LSL, Microllam® LVL, and untreated Parallam® PSL are intended for dry-use applications

## CEILING JOIST SPAN TABLE

### 1½" TimberStrand® LSL Ceiling Joists

On-Center Spacing	Joist Depth	Design Load			
		10 LL / 5 DL	20 LL / 10 DL	30 LL / 10 DL	40 LL / 10 DL
Maximum Ceiling Joist Clear Span					
12"	5½"	15'-8"	12'-4"	10'-9"	9'-9"
	7¼"	21'-8"	17'-2"	14'-11"	13'-6"
	9½"	28'-6"	22'-6"	19'-7"	17'-9"
	11⅞"	35'-8"	28'-2"	24'-7"	22'-3"
16"	5½"	14'-2"	11'-2"	9'-9"	8'-10"
	7¼"	19'-8"	15'-7"	13'-6"	12'-3"
	9½"	25'-10"	20'-5"	17'-9"	16'-1"
	11⅞"	32'-4"	25'-7"	22'-3"	20'-2"
19.2"	5½"	13'-4"	10'-6"	9'-2"	8'-3"
	7¼"	18'-6"	14'-7"	12'-8"	11'-6"
	9½"	24'-4"	19'-2"	16'-8"	15'-1"
	11⅞"	30'-5"	24'-0"	20'-11"	18'-11"
24"	5½"	12'-4"	9'-9"	8'-5"	7'-8"
	7¼"	17'-2"	13'-6"	11'-9"	10'-8"
	9½"	22'-6"	17'-9"	15'-6"	14'-0"
	11⅞"	28'-2"	22'-3"	19'-4"	17'-6"

### How to Use This Table

- Determine the live load and dead load condition.
- Determine the joist **On-Center Spacing**.
- Scan down the appropriate **Design Load** column until you find a cell (within your on-center spacing) that meets or exceeds the span of your application.
- Select the TimberStrand® LSL joist depth.

### General Notes

- Table is based on:
  - Deflection criteria of L/360 live load and L/240 total load.
  - Uniform loads.
  - 100% load duration.
  - Minimum ceiling joist bearing length of 2", assuming a top plate  $F_{c\perp}$  of 425 psi.
- Lateral support required at bearing and along ceiling joist compression edge at 48" on-center (maximum).
- Connect to rafter per **Rafter Span** tables (see pages 4–7).

# RAFTER SPAN AND HEEL CONNECTION TABLES

## No Directly Applied Ceiling

On-Center Spacing	Rafter Depth	Span/ Nailing	1½" TimberStrand® LSL Rafters														
			Roof Snow Load (PSF)														
			20 LL + 10 DL			25 LL + 10 DL			30 LL + 10 DL			35 LL + 10 DL			40 LL + 10 DL		
			Roof Slope			Roof Slope			Roof Slope			Roof Slope			Roof Slope		
4:12	8:12	12:12	4:12	8:12	12:12	4:12	8:12	12:12	4:12	8:12	12:12	4:12	8:12	12:12	4:12	8:12	12:12
12"	5½"	Span	13'-9"			13'-1"			12'-6"			11'-11"			11'-5"		
		Nail Qty. <sup>(1)</sup>	6	4	3	7	4	3	7	4	3	8	4	3	8	5	3
	7¼"	Span	17'-8"			17'-1"			16'-6"			15'-10"			15'-4"		
		Nail Qty. <sup>(1)</sup>	8	4	3	9	5	4	10	5	4	10	6	4	11	6	4
	9½"	Span	21'-7"			20'-10"			20'-2"			19'-5"			18'-9"		
		Nail Qty. <sup>(1)</sup>	10	5	4	11	6	4	12	6	5	13	7	5	14	7	5
11⅝"	Span	26'-11"			25'-9"			24'-9"			23'-10"			23'-1"			
	Nail Qty. <sup>(1)</sup>	12	7	5	13	7	5	14	8	6	*	8	6	*	9	6	
16"	5½"	Span	12'-6"			11'-11"			11'-5"			10'-10"			10'-4"		
		Nail Qty. <sup>(1)</sup>	7	4	3	8	5	3	9	5	4	9	5	4	10	5	4
	7¼"	Span	16'-5"			15'-10"			15'-4"			14'-9"			14'-3"		
		Nail Qty. <sup>(1)</sup>	10	5	4	11	6	4	12	6	5	13	7	5	14	7	5
	9½"	Span	20'-1"			19'-5"			18'-9"			18'-0"			17'-5"		
		Nail Qty. <sup>(1)</sup>	12	6	5	13	7	5	15	8	6	*	8	6	*	9	6
11⅝"	Span	24'-6"			23'-4"			22'-5"			21'-8"			21'-1"			
	Nail Qty. <sup>(1)</sup>	14	8	6	*	9	6	*	9	7	*	10	7	*	11	8	
19.2"	5½"	Span	11'-9"			11'-3"			10'-9"			10'-2"			9'-9"		
		Nail Qty. <sup>(1)</sup>	8	5	3	9	5	4	10	5	4	11	6	4	11	6	4
	7¼"	Span	15'-8"			15'-2"			14'-8"			14'-0"			13'-5"		
		Nail Qty. <sup>(1)</sup>	11	6	4	12	7	5	14	7	5	15	8	6	15	8	6
	9½"	Span	19'-2"			18'-6"			17'-11"			17'-3"			16'-8"		
		Nail Qty. <sup>(1)</sup>	13	7	5	15	8	6	*	9	6	*	9	7	*	10	7
11⅝"	Span	23'-0"			22'-0"			21'-2"			20'-8"			19'-10"			
	Nail Qty. <sup>(1)</sup>	*	9	6	*	10	7	*	10	7	*	11	8	*	12	8	
24"	5½"	Span	10'-11"			10'-5"			10'-0"			9'-6"			9'-1"		
		Nail Qty. <sup>(1)</sup>	10	5	4	11	6	4	11	6	4	12	6	5	13	7	5
	7¼"	Span	14'-10"			14'-4"			13'-8"			13'-0"			12'-5"		
		Nail Qty. <sup>(1)</sup>	13	7	5	15	8	6	*	8	6	*	9	6	*	9	7
	9½"	Span	18'-2"			17'-6"			16'-11"			16'-3"			15'-9"		
		Nail Qty. <sup>(1)</sup>	*	9	6	*	9	7	*	10	7	*	11	8	*	12	8
11⅝"	Span	21'-5"			20'-8"			20'-1"			19'-3"			18'-7"			
	Nail Qty. <sup>(1)</sup>	*	10	7	*	11	8	*	12	9	*	13	9	*	14	10	

(1) Nail Qty. indicates required number of 16d (0.131" x 3¼") nails for heel/lap connection.

\* Contact your Weyerhaeuser representative for appropriate connection information.

## How to Use These Tables

- Determine the roof snow load in pounds per square foot (psf).
- Determine the rafter **On-Center Spacing**.
- Scan down the appropriate **Roof Snow Load** column until you find a cell (within your on-center spacing) that meets or exceeds the span of your application.
- Select the TimberStrand® LSL **Rafter Depth** and note the number of 16d (0.131" x 3¼") nails required at the heel and ceiling joist lap connection for your roof slope.
- Size ceiling joists. See page 3.

## General Notes

- Tables are based on:
  - Deflection criteria as follows:
    - For sloped rafter lengths ≤ 20': Total load is L/120  
Live load is L/180
    - For sloped rafter lengths > 20': Total load is the greater of 2" or L/180  
Live load is the greater of 1.33" or L/240
  - Minimum rafter bearing length of 3½", assuming a top plate F<sub>cL</sub> of 425 psi.
  - Uniform loads.
  - 115% load duration.
- Bold italic** values require 2x6 exterior bearing wall.
- Spans shown are the maximum horizontal distance between supports.
- Purlins may be installed (per section R802.5.1 of the 2015 IRC and section R802.4.5 of the 2018 IRC) to reduce rafter spans.
- Interpolation to determine nail quantity for other slopes is permitted.

# RAFTER SPAN AND HEEL CONNECTION TABLES

## No Directly Applied Ceiling *continued*

On-Center Spacing	Rafter Depth	Span/ Nailing	1½" TimberStrand® LSL Rafters																	
			Roof Snow Load (PSF)																	
			45 LL + 10 DL			50 LL + 10 DL			55 LL + 10 DL			60 LL + 10 DL			70 LL + 10 DL			80 LL + 10 DL		
			Roof Slope			Roof Slope			Roof Slope			Roof Slope			Roof Slope			Roof Slope		
			4:12	8:12	12:12	4:12	8:12	12:12	4:12	8:12	12:12	4:12	8:12	12:12	4:12	8:12	12:12	4:12	8:12	12:12
12"	5½"	Span	10'-11"			10'-7"			10'-3"			10'-0"			9'-6"			9'-1"		
		Nail Qty. <sup>(1)</sup>	9	5	3	9	5	4	10	5	4	10	5	4	11	6	4	11	6	4
	7¼"	Span	14'-11"			14'-6"			14'-1"			13'-8"			13'-0"			12'-5"		
		Nail Qty. <sup>(1)</sup>	12	6	5	13	7	5	13	7	5	14	7	5	15	8	6	*	8	6
	9½"	Span	18'-2"			17'-9"			17'-4"			16'-11"			16'-3"			15'-9"		
		Nail Qty. <sup>(1)</sup>	14	8	5	15	8	6	*	9	6	*	9	6	*	10	7	*	11	7
	11⅞"	Span	22'-4"			21'-6"			20'-10"			20'-3"			19'-3"			18'-7"		
		Nail Qty. <sup>(1)</sup>	*	9	7	*	10	7	*	10	7	*	11	7	*	11	8	*	12	9
16"	5½"	Span	10'-0"			9'-7"			9'-4"			9'-1"			8'-7"			8'-3"		
		Nail Qty. <sup>(1)</sup>	10	6	4	11	6	4	11	6	4	12	6	4	13	7	5	14	7	5
	7¼"	Span	13'-8"			13'-3"			12'-10"			12'-5"			11'-10"			11'-4"		
		Nail Qty. <sup>(1)</sup>	14	8	5	15	8	6	*	8	6	*	9	6	*	9	7	*	10	7
	9½"	Span	16'-11"			16'-6"			16'-1"			15'-9"			15'-2"			14'-8"		
		Nail Qty. <sup>(1)</sup>	*	9	7	*	10	7	*	10	7	*	11	8	*	12	8	*	13	9
	11⅞"	Span	20'-3"			19'-7"			19'-0"			18'-7"			17'-10"			17'-3"		
		Nail Qty. <sup>(1)</sup>	*	11	8	*	12	8	*	12	9	*	13	9	*	14	10	*	15	11
19.2"	5½"	Span	9'-5"			9'-1"			8'-9"			8'-6"			8'-1"			7'-9"		
		Nail Qty. <sup>(1)</sup>	12	6	4	12	6	5	13	7	5	13	7	5	14	8	5	15	8	6
	7¼"	Span	12'-11"			12'-5"			12'-1"			11'-9"			11'-2"			10'-8"		
		Nail Qty. <sup>(1)</sup>	*	9	6	*	9	6	*	9	7	*	10	7	*	10	7	*	11	8
	9½"	Span	16'-2"			15'-9"			15'-5"			15'-1"			14'-6"			13'-11"		
		Nail Qty. <sup>(1)</sup>	*	11	8	*	11	8	*	12	8	*	12	9	*	14	9	*	15	10
	11⅞"	Span	19'-1"			18'-7"			18'-2"			17'-9"			17'-1"			16'-6"		
		Nail Qty. <sup>(1)</sup>	*	13	9	*	13	9	*	14	10	*	15	10	*	*	11	*	*	12
24"	5½"	Span	8'-9"			8'-5"			8'-2"			7'-11"			7'-6"			7'-2"		
		Nail Qty. <sup>(1)</sup>	13	7	5	14	7	5	15	8	5	15	8	6	*	9	6	*	9	6
	7¼"	Span	12'-0"			11'-7"			11'-2"			10'-11"			10'-4"			9'-11"		
		Nail Qty. <sup>(1)</sup>	*	10	7	*	10	7	*	11	8	*	11	8	*	12	8	*	13	9
	9½"	Span	15'-4"			14'-11"			14'-7"			14'-2"			13'-6"			12'-11"		
		Nail Qty. <sup>(1)</sup>	*	13	9	*	13	9	*	14	10	*	15	10	*	*	11	*	*	12
	11⅞"	Span	18'-0"			17'-7"			17'-2"			16'-9"			16'-2"			15'-7"		
		Nail Qty. <sup>(1)</sup>	*	15	10	*	*	11	*	*	11	*	*	12	*	*	13	*	*	14

(1) Nail Qty. indicates required number of 16d (0.131" x 3¼") nails for heel/lap connection.

\* Contact your Weyerhaeuser representative for appropriate connection information.

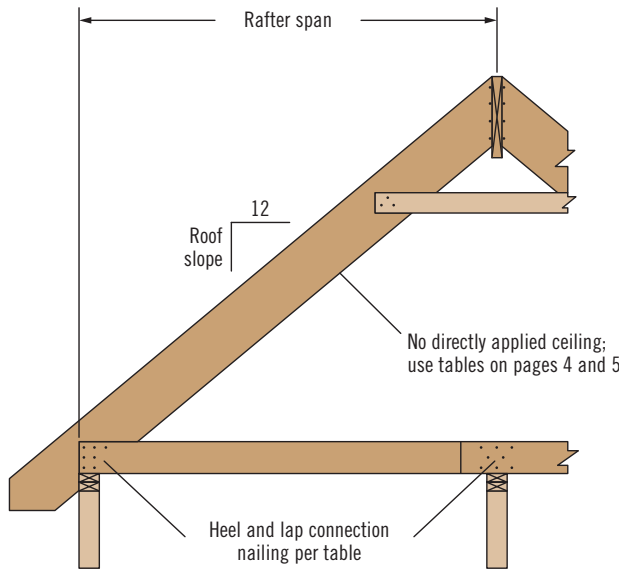

See details on pages 12–14 for additional connection information

See How to Use These Tables and General Notes on page 4

# RAFTER SPAN AND HEEL CONNECTION TABLES

## Directly Applied Ceiling

On-Center Spacing	Rafter Depth	Span/ Nailing	1½" TimberStrand® LSL Rafters														
			Roof Snow Load (PSF)														
			20 LL + 15 DL			25 LL + 15 DL			30 LL + 15 DL			35 LL + 15 DL			40 LL + 15 DL		
			Roof Slope			Roof Slope			Roof Slope			Roof Slope			Roof Slope		
4:12	8:12	12:12	4:12	8:12	12:12	4:12	8:12	12:12	4:12	8:12	12:12	4:12	8:12	12:12	4:12	8:12	12:12
12"	5½"	Span	11'-3"			10'-10"			10'-6"			10'-2"			9'-11"		
		Nail Qty. <sup>(1)</sup>	6	3	3	7	4	3	7	4	3	7	4	3	8	4	3
	7¼"	Span	15'-3"			14'-9"			14'-5"			14'-0"			13'-7"		
		Nail Qty. <sup>(1)</sup>	8	4	3	9	5	4	10	5	4	10	6	4	11	6	4
	9½"	Span	18'-7"			18'-1"			17'-7"			17'-2"			16'-10"		
		Nail Qty. <sup>(1)</sup>	10	5	4	11	6	4	12	6	5	13	7	5	13	7	5
	11⅛"	Span	23'-0"			22'-1"			21'-4"			20'-9"			20'-2"		
		Nail Qty. <sup>(1)</sup>	12	7	5	13	7	5	14	8	6	15	8	6	*	9	6
16"	5½"	Span	10'-3"			9'-11"			9'-7"			9'-3"			9'-0"		
		Nail Qty. <sup>(1)</sup>	7	4	3	8	4	3	8	5	3	9	5	4	9	5	4
	7¼"	Span	14'-1"			13'-7"			13'-2"			12'-9"			12'-4"		
		Nail Qty. <sup>(1)</sup>	10	5	4	11	6	4	11	6	5	12	7	5	13	7	5
	9½"	Span	17'-4"			16'-10"			16'-5"			16'-0"			15'-8"		
		Nail Qty. <sup>(1)</sup>	12	7	5	13	7	5	14	8	6	15	8	6	*	9	6
	11⅛"	Span	20'-10"			20'-1"			19'-5"			18'-11"			18'-6"		
		Nail Qty. <sup>(1)</sup>	14	8	6	*	9	6	*	9	7	*	10	7	*	10	7
19.2"	5½"	Span	9'-8"			9'-4"			9'-0"			8'-9"			8'-6"		
		Nail Qty. <sup>(1)</sup>	8	4	3	9	5	4	9	5	4	10	5	4	11	6	4
	7¼"	Span	13'-3"			12'-9"			12'-4"			12'-0"			11'-8"		
		Nail Qty. <sup>(1)</sup>	11	6	5	12	7	5	13	7	5	14	7	5	15	8	6
	9½"	Span	16'-6"			16'-1"			15'-8"			15'-4"			15'-0"		
		Nail Qty. <sup>(1)</sup>	14	7	6	15	8	6	*	9	6	*	9	7	*	10	7
	11⅛"	Span	19'-8"			18'-11"			18'-6"			18'-0"			17'-8"		
		Nail Qty. <sup>(1)</sup>	*	9	6	*	10	7	*	10	7	*	11	8	*	12	8
24"	5½"	Span	9'-0"			8'-8"			8'-4"			8'-1"			7'-10"		
		Nail Qty. <sup>(1)</sup>	9	5	4	10	5	4	11	6	4	11	6	4	12	6	5
	7¼"	Span	12'-4"			11'-10"			11'-6"			11'-1"			10'-10"		
		Nail Qty. <sup>(1)</sup>	13	7	5	14	7	5	15	8	6	*	9	6	*	9	6
	9½"	Span	15'-8"			15'-2"			14'-10"			14'-6"			14'-1"		
		Nail Qty. <sup>(1)</sup>	*	9	6	*	10	7	*	10	7	*	11	8	*	12	8
	11⅛"	Span	18'-5"			17'-11"			17'-6"			17'-1"			16'-8"		
		Nail Qty. <sup>(1)</sup>	*	10	8	*	11	8	*	12	9	*	13	9	*	14	10

(1) **Nail Qty.** indicates required number of 16d (0.131" x 3¼") nails for heel/lap connection.

\* Contact your Weyerhaeuser representative for appropriate connection information.

## How to Use These Tables

- Determine the roof snow load in pounds per square foot (psf).
- Determine the rafter **On-Center Spacing**.
- Scan down the appropriate **Roof Snow Load** column until you find a cell (within your on-center spacing) that meets or exceeds the span of your application.
- Select the TimberStrand® LSL **Rafter Depth** and note the number of 16d (0.131" x 3¼") nails required at the heel connection for your roof slope.
- Size ceiling joists. See page 3.

## General Notes

- Tables are based on:
  - Deflection criteria:
    - For sloped rafter lengths ≤ 20': Total load is L/180  
Live load is L/240
    - For sloped rafter lengths > 20': Total load is the greater of 1.33" or L/240  
Live load is the greater of 1" or L/360
  - Minimum rafter bearing length of 3½", assuming a top plate  $F_{c\perp}$  of 425 psi.
  - Uniform loads.
  - 115% load duration.
- Bold italic** values require 2x6 exterior bearing wall.
- Lateral support required at bearing and along rafter compression edge at 12" on-center maximum.
- Spans shown are the maximum horizontal distance between supports.
- Purlins may be installed (per section R802.5.1 of the 2015 IRC and section R802.4.5 of the 2018 IRC) to reduce rafter spans.
- Interpolation to determine nail quantity for other slopes is permitted.

# RAFTER SPAN AND HEEL CONNECTION TABLES

## Directly Applied Ceiling *continued*

On-Center Spacing	Rafter Depth	Span/ Nailing	1½" TimberStrand® LSL Rafters																	
			Roof Snow Load (PSF)																	
			45 LL + 15 DL			50 LL + 15 DL			55 LL + 15 DL			60 LL + 15 DL			70 LL + 15 DL			80 LL + 15 DL		
			Roof Slope			Roof Slope			Roof Slope			Roof Slope			Roof Slope			Roof Slope		
			4:12	8:12	12:12	4:12	8:12	12:12	4:12	8:12	12:12	4:12	8:12	12:12	4:12	8:12	12:12	4:12	8:12	12:12
12"	5½"	Span	9'-8"			9'-5"			9'-2"			9'-0"			8'-7"			8'-3"		
		Nail Qty. <sup>(1)</sup>	8	5	3	9	5	3	9	5	4	10	5	4	10	6	4	11	6	4
	7¼"	Span	13'-3"			12'-11"			12'-8"			12'-5"			11'-10"			11'-4"		
		Nail Qty. <sup>(1)</sup>	12	6	5	12	7	5	13	7	5	13	7	5	14	8	5	15	8	6
	9½"	Span	16'-6"			16'-3"			15'-11"			15'-8"			15'-2"			14'-8"		
		Nail Qty. <sup>(1)</sup>	14	8	6	15	8	6	*	9	6	*	9	6	*	10	7	*	10	7
11⅞"	Span	19'-7"			19'-2"			18'-10"			18'-6"			17'-10"			17'-3"			
	Nail Qty. <sup>(1)</sup>	*	9	7	*	10	7	*	10	7	*	11	7	*	11	8	*	12	9	
16"	5½"	Span	8'-9"			8'-7"			8'-4"			8'-2"			7'-10"			7'-6"		
		Nail Qty. <sup>(1)</sup>	10	5	4	10	6	4	11	6	4	11	6	4	12	7	5	13	7	5
	7¼"	Span	12'-1"			11'-9"			11'-6"			11'-3"			10'-9"			10'-3"		
		Nail Qty. <sup>(1)</sup>	14	7	5	15	8	6	15	8	6	*	8	6	*	9	6	*	10	7
	9½"	Span	15'-4"			15'-1"			14'-10"			14'-7"			14'-0"			13'-5"		
		Nail Qty. <sup>(1)</sup>	*	9	7	*	10	7	*	10	7	*	11	8	*	12	8	*	13	9
11⅞"	Span	18'-1"			17'-10"			17'-6"			17'-3"			16'-8"			16'-1"			
	Nail Qty. <sup>(1)</sup>	*	11	8	*	12	8	*	12	9	*	13	9	*	14	10	*	15	10	
19.2"	5½"	Span	8'-3"			8'-1"			7'-11"			7'-9"			7'-4"			7'-1"		
		Nail Qty. <sup>(1)</sup>	11	6	4	12	6	5	12	7	5	13	7	5	14	7	5	14	8	5
	7¼"	Span	11'-4"			11'-1"			10'-10"			10'-7"			10'-1"			9'-8"		
		Nail Qty. <sup>(1)</sup>	*	8	6	*	9	6	*	9	6	*	9	7	*	10	7	*	11	8
	9½"	Span	14'-8"			14'-5"			14'-1"			13'-10"			13'-2"			12'-7"		
		Nail Qty. <sup>(1)</sup>	*	11	8	*	11	8	*	12	8	*	12	9	*	13	9	*	14	10
11⅞"	Span	17'-4"			17'-0"			16'-9"			16'-5"			15'-11"			15'-4"			
	Nail Qty. <sup>(1)</sup>	*	13	9	*	13	9	*	14	10	*	15	10	*	*	11	*	*	12	
24"	5½"	Span	7'-8"			7'-6"			7'-4"			7'-2"			6'-10"			6'-7"		
		Nail Qty. <sup>(1)</sup>	13	7	5	13	7	5	14	7	5	15	8	6	*	8	6	*	9	6
	7¼"	Span	10'-6"			10'-3"			10'-1"			9'-10"			9'-5"			9'-0"		
		Nail Qty. <sup>(1)</sup>	*	9	7	*	10	7	*	10	7	*	11	8	*	12	8	*	12	9
	9½"	Span	13'-9"			13'-5"			13'-1"			12'-10"			12'-3"			11'-9"		
		Nail Qty. <sup>(1)</sup>	*	12	9	*	13	9	*	14	10	*	14	10	*	15	11	*	*	11
11⅞"	Span	16'-4"			16'-1"			15'-10"			15'-7"			15'-0"			14'-6"			
	Nail Qty. <sup>(1)</sup>	*	15	10	*	*	11	*	*	12	*	*	12	*	*	13	*	*	14	

(1) Nail Qty. indicates required number of 16d (0.131" x 3¼") nails for heel/lap connection.

\* Contact your Weyerhaeuser representative for appropriate connection information.

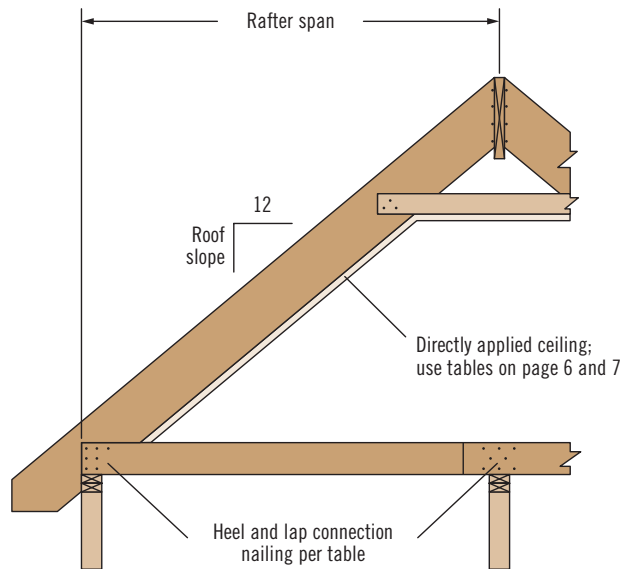

See details on pages 12–14 for additional connection information

See How to Use These Tables and General Notes on page 6

# HIP SPAN TABLE

## Single-Span Hip Members

Member Type	No. of Plies	Member Depth	Roof Snow Load (PSF)										
			20 LL 15 DL	25 LL 15 DL	30 LL 15 DL	35 LL 15 DL	40 LL 15 DL	45 LL 15 DL	50 LL 15 DL	55 LL 15 DL	60 LL 15 DL	70 LL 15 DL	80 LL 15 DL
			Maximum Hip Spans										
1½" TimberStrand® LSL	1	7¼"	15'-3"	14'-10"	14'-6"	14'-2"	13'-11"	13'-8"	13'-5"	13'-2"	13'-0"	12'-8"	12'-4"
		9½"	18'-7"	18'-1"	17'-8"	17'-3"	16'-11"	16'-7"	16'-4"	16'-1"	15'-10"	15'-5"	15'-0"
		11⅞"	21'-11"	21'-4"	20'-10"	20'-4"	19'-11"	19'-7"	19'-3"	18'-11"	18'-8"	18'-1"	17'-8"
	2	7¼"	17'-10"	17'-5"	17'-0"	16'-8"	16'-4"	16'-0"	15'-9"	15'-6"	15'-4"	14'-11"	14'-6"
		9½"	21'-9"	21'-3"	20'-9"	20'-3"	19'-11"	19'-7"	19'-3"	18'-11"	18'-8"	18'-2"	17'-8"
		11⅞"	25'-7"	25'-0"	24'-5"	23'-11"	23'-5"	23'-0"	22'-8"	22'-3"	21'-11"	21'-4"	20'-10"
	3	7¼"	19'-6"	19'-1"	18'-7"	18'-3"	17'-11"	17'-7"	17'-4"	17'-0"	16'-10"	16'-4"	16'-0"
		9½"	23'-9"	23'-2"	22'-8"	22'-3"	21'-10"	21'-5"	21'-1"	20'-9"	20'-6"	19'-11"	19'-6"
		11⅞"	25'-8"	25'-8"	25'-8"	25'-8"	25'-8"	25'-3"	24'-10"	24'-5"	24'-1"	23'-6"	22'-11"
1¾" TimberStrand® LSL	1	9½"	19'-5"	18'-11"	18'-5"	18'-1"	17'-8"	17'-4"	17'-1"	16'-10"	16'-7"	16'-1"	15'-8"
		11⅞"	22'-10"	22'-3"	21'-9"	21'-3"	20'-10"	20'-6"	20'-1"	19'-9"	19'-6"	19'-0"	18'-6"
		14"	25'-8"	25'-1"	24'-6"	24'-0"	23'-6"	23'-1"	22'-8"	22'-4"	22'-0"	21'-5"	20'-10"
	2	9½"	22'-8"	22'-1"	21'-7"	21'-2"	20'-9"	20'-5"	20'-1"	19'-9"	19'-6"	18'-11"	18'-6"
		11⅞"	25'-8"	25'-8"	25'-5"	24'-11"	24'-5"	24'-0"	23'-8"	23'-3"	22'-11"	22'-4"	21'-10"
		14"	25'-8"	25'-8"	25'-8"	25'-8"	25'-8"	25'-8"	25'-8"	25'-8"	25'-8"	25'-2"	24'-7"
	3	9½"	24'-9"	24'-2"	23'-8"	23'-2"	22'-9"	22'-4"	22'-0"	21'-8"	21'-4"	20'-10"	20'-4"
		11⅞"	25'-8"	25'-8"	25'-8"	25'-8"	25'-8"	25'-8"	25'-8"	25'-8"	25'-2"	24'-6"	23'-11"
		14"	25'-8"	25'-8"	25'-8"	25'-8"	25'-8"	25'-8"	25'-8"	25'-8"	25'-8"	25'-8"	25'-8"
1¾" Microllam® LVL	1	9½"	20'-1"	19'-7"	19'-1"	18'-8"	18'-3"	17'-11"	17'-8"	17'-4"	17'-1"	16'-8"	16'-2"
		11¼"	23'-2"	22'-7"	22'-0"	21'-7"	21'-1"	20'-9"	20'-5"	20'-1"	19'-9"	19'-2"	18'-8"
		14"	25'-8"	25'-8"	25'-8"	25'-4"	24'-10"	24'-4"	23'-11"	23'-7"	23'-2"	22'-7"	21'-11"
		16"	25'-8"	25'-8"	25'-8"	25'-8"	25'-8"	25'-8"	25'-8"	25'-8"	25'-0"	23'-7"	22'-5"
	2	9½"	23'-6"	22'-11"	22'-5"	21'-11"	21'-6"	21'-1"	20'-9"	20'-5"	20'-2"	19'-7"	19'-2"
		11¼"	25'-8"	25'-8"	25'-8"	25'-4"	24'-10"	24'-5"	24'-0"	23'-7"	23'-3"	22'-8"	22'-1"
		14"	25'-8"	25'-8"	25'-8"	25'-8"	25'-8"	25'-8"	25'-8"	25'-8"	25'-8"	25'-8"	25'-8"
	3	9½"	25'-8"	25'-1"	24'-6"	24'-0"	23'-7"	23'-2"	22'-9"	22'-5"	22'-1"	21'-6"	21'-0"
		11¼"	25'-8"	25'-8"	25'-8"	25'-8"	25'-8"	25'-8"	25'-8"	25'-8"	25'-6"	24'-10"	24'-3"
14"	25'-8"	25'-8"	25'-8"	25'-8"	25'-8"	25'-8"	25'-8"	25'-8"	25'-8"	25'-8"	25'-8"	25'-8"	

## How to Use These Tables

- Determine the roof snow load in pounds per square foot (psf).
- Scan down the appropriate **Roof Snow Load** column until you find a cell that meets or exceeds the span of your application.
- Select the TimberStrand® LSL or Microllam® LVL type and depth, and note the number of plies required.
- Refer to reaction tables on page 10 to help size supporting members.

## General Notes

- Tables are based on:
  - Deflection criteria of L/180 total load and L/240 live load.
  - Uniform loads.
  - 115% load duration.
  - Minimum hip/valley member bearing length of 3½", assuming a top plate  $F_{c\perp}$  of 425 psi.
- Lateral support required at bearing.
- Multiple-member beam connections assume equal loads and spans from each side. For other conditions, contact your Weyerhaeuser representative.
- Spans shown are the maximum horizontal distance between supports.

## Single-Span Hip/Valley

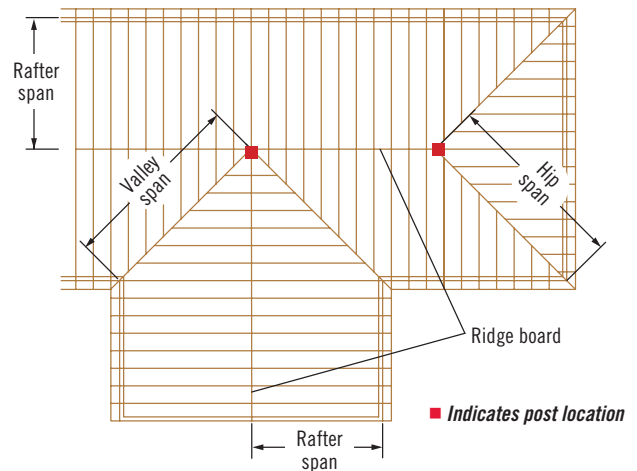

**TIP:** Sizing deeper beam members, rather than using multiple plies, usually results in a more economical system.

## Rafter-to-Hip/Valley Span

Rafter Span	8'	9'	10'	11'	12'	13'	14'	15'	16'	17'	18'	19'	20'
Hip/Valley Span	11'-4"	12'-9"	14'-2"	15'-7"	17'-0"	18'-5"	19'-10"	21'-3"	22'-7"	24'-0"	25'-5"	26'-10"	28'-3"

- Assumes equal rafter slopes on both sides of hip/valley.
- All spans shown are horizontal spans.
- For rafter spans not shown, hip/valley span = rafter span x 1.414.



# VALLEY SPAN TABLES

## Single-Span Valley Beams

Member Type	No. of Plies	Member Depth	Roof Snow Load (PSF)											
			20 LL 15 DL	25 LL 15 DL	30 LL 15 DL	35 LL 15 DL	40 LL 15 DL	45 LL 15 DL	50 LL 15 DL	55 LL 15 DL	60 LL 15 DL	70 LL 15 DL	80 LL 15 DL	
1/2" TimberStrand® LSL	1	7 1/2"	11'-5"	11'-2"	10'-10"	10'-7"	10'-5"	10'-2"	10'-0"	9'-10"	9'-8"	9'-5"	9'-1"	
		9 1/2"	13'-11"	13'-7"	13'-3"	12'-11"	12'-8"	12'-5"	12'-2"	12'-0"	11'-10"	11'-6"	11'-1"	
		11 1/2"	16'-5"	16'-0"	15'-7"	15'-3"	14'-11"	14'-7"	14'-4"	14'-1"	13'-11"	13'-6"	13'-1"	
	2	7 1/2"	13'-6"	13'-2"	12'-10"	12'-7"	12'-4"	12'-1"	11'-10"	11'-8"	11'-6"	11'-2"	10'-10"	
		9 1/2"	16'-6"	16'-0"	15'-8"	15'-4"	15'-0"	14'-8"	14'-5"	14'-3"	14'-0"	13'-7"	13'-2"	
		11 1/2"	19'-5"	18'-11"	18'-5"	18'-0"	17'-8"	17'-4"	17'-0"	16'-9"	16'-6"	16'-0"	15'-6"	
	3	7 1/2"	14'-10"	14'-6"	14'-2"	13'-10"	13'-7"	13'-4"	13'-1"	12'-10"	12'-8"	12'-4"	12'-0"	
		9 1/2"	18'-2"	17'-8"	17'-3"	16'-10"	16'-6"	16'-2"	15'-11"	15'-8"	15'-5"	15'-0"	14'-7"	
		11 1/2"	21'-4"	20'-9"	20'-3"	19'-10"	19'-5"	19'-1"	18'-9"	18'-5"	18'-2"	17'-8"	17'-2"	
	1 3/4" TimberStrand® LSL	1	9 1/2"	14'-7"	14'-2"	13'-10"	13'-6"	13'-3"	13'-0"	12'-9"	12'-7"	12'-4"	12'-0"	11'-7"
			11 1/2"	17'-2"	16'-8"	16'-4"	15'-11"	15'-7"	15'-4"	15'-0"	14'-9"	14'-7"	14'-2"	13'-8"
			14"	19'-5"	18'-10"	18'-5"	18'-0"	17'-7"	17'-3"	16'-11"	16'-8"	16'-5"	15'-8"	14'-11"
2		9 1/2"	17'-3"	16'-9"	16'-4"	16'-0"	15'-8"	15'-5"	15'-1"	14'-10"	14'-8"	14'-3"	13'-10"	
		11 1/2"	20'-3"	19'-9"	19'-3"	18'-10"	18'-5"	18'-1"	17'-10"	17'-6"	17'-3"	16'-9"	16'-3"	
		14"	22'-11"	22'-3"	21'-9"	21'-3"	20'-10"	20'-5"	20'-1"	19'-9"	19'-5"	18'-11"	18'-4"	
3		9 1/2"	18'-11"	18'-5"	18'-0"	17'-7"	17'-3"	16'-11"	16'-8"	16'-5"	16'-2"	15'-8"	15'-4"	
		11 1/2"	22'-4"	21'-9"	21'-2"	20'-9"	20'-4"	19'-11"	19'-7"	19'-4"	19'-0"	18'-6"	18'-0"	
		14"	25'-2"	24'-6"	23'-11"	23'-5"	22'-11"	22'-6"	22'-2"	21'-9"	21'-5"	20'-10"	20'-4"	
1 3/4" Microllam® LVL		1	9 1/4"	15'-1"	14'-8"	14'-4"	14'-0"	13'-8"	13'-5"	13'-2"	13'-0"	12'-9"	12'-4"	11'-11"
			11 1/4"	17'-5"	16'-11"	16'-6"	16'-1"	15'-9"	15'-6"	15'-3"	15'-0"	14'-9"	14'-3"	13'-9"
			14"	20'-5"	19'-10"	19'-4"	18'-11"	18'-6"	18'-2"	17'-8"	17'-1"	16'-7"	15'-8"	14'-11"
	16"		22'-6"	21'-10"	20'-9"	19'-10"	19'-0"	*	*	*	*	*	*	
	2	9 1/4"	17'-10"	17'-4"	16'-11"	16'-6"	16'-2"	15'-11"	15'-7"	15'-4"	15'-1"	14'-8"	14'-3"	
		11 1/4"	20'-7"	20'-0"	19'-6"	19'-1"	18'-8"	18'-4"	18'-0"	17'-9"	17'-6"	17'-0"	16'-5"	
		14"	24'-2"	23'-6"	22'-11"	22'-5"	21'-11"	21'-6"	21'-2"	20'-10"	20'-6"	19'-11"	19'-3"	
		16"	25'-8"	25'-8"	25'-3"	24'-9"	24'-3"	23'-9"	23'-4"	23'-0"	22'-7"	21'-11"	20'-10"	
	3	9 1/4"	25'-8"	25'-8"	25'-8"	25'-8"	25'-8"	25'-7"	24'-8"	23'-11"	23'-2"	*	*	
		11 1/4"	19'-7"	19'-1"	18'-7"	18'-2"	17'-10"	17'-6"	17'-3"	16'-11"	16'-8"	16'-3"	15'-9"	
		14"	22'-7"	22'-0"	21'-6"	21'-0"	20'-7"	20'-3"	19'-10"	19'-7"	19'-3"	18'-9"	18'-2"	
		16"	25'-8"	25'-8"	25'-3"	24'-8"	24'-2"	23'-9"	23'-4"	22'-11"	22'-7"	22'-0"	21'-4"	
3	18"	25'-8"	25'-8"	25'-8"	25'-8"	25'-8"	25'-8"	25'-8"	25'-8"	25'-8"	25'-8"	25'-4"		

\* Exceeds bearing limit; contact your Weyerhaeuser representative for assistance.

See How to Use These Tables and General Notes on page 8

## CUT LENGTH CALCULATION

### Slope Factors

Type	Roof Slope								
	4:12	5:12	6:12	7:12	8:12	9:12	10:12	11:12	12:12
Rafter	1.054	1.083	1.118	1.158	1.202	1.250	1.302	1.357	1.414
Hip/Valley	1.027	1.043	1.061	1.082	1.106	1.132	1.161	1.192	1.225

### D Factors

Rafter Depth	Roof Slope								
	4:12	5:12	6:12	7:12	8:12	9:12	10:12	11:12	12:12
5 1/2"	1 7/8"	2 3/8"	2 3/4"	3 1/4"	3 3/4"	4 1/8"	4 5/8"	5 1/8"	5 1/2"
7 1/4"	2 1/2"	3 1/8"	3 5/8"	4 1/4"	4 7/8"	5 1/2"	6 1/8"	6 3/4"	7 1/4"
9 1/2"	3 1/8"	3 7/8"	4 3/8"	5 1/4"	5 7/8"	6 1/2"	7 1/4"	8 1/8"	9 1/4"
11 1/4"	3 3/4"	4 3/8"	5 1/8"	6 1/4"	7 1/8"	8 1/4"	9 1/8"	10 3/8"	11 1/4"
11 1/2"	4"	5"	6"	7"	8"	9"	10"	11"	11 7/8"

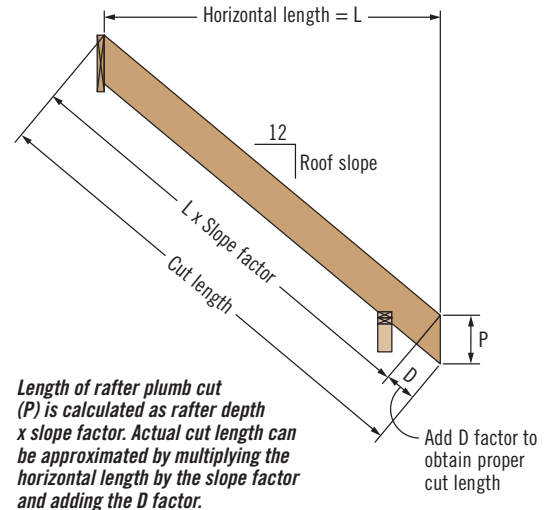

# HIP AND VALLEY REACTION TABLES

## Single-Span Hip Member (lbs)

House Width	Hip Span	Location	Roof Snow Load (PSF)										
			20 LL 15 DL	25 LL 15 DL	30 LL 15 DL	35 LL 15 DL	40 LL 15 DL	45 LL 15 DL	50 LL 15 DL	55 LL 15 DL	60 LL 15 DL	70 LL 15 DL	80 LL 15 DL
			Hip Member Reaction (lbs)										
12'	8'-6"	High	0	0	0	0	0	0	0	0	0	0	
		Low	74	83	92	101	110	119	128	137	146	164	182
16'	11'-4"	High	0	0	0	0	0	0	0	0	20	84	148
		Low	132	148	164	180	196	212	228	244	260	292	324
20'	14'-2"	High	0	0	12	62	112	162	212	262	312	412	512
		Low	206	231	256	281	306	331	356	381	406	456	506
24'	17'-0"	High	93	165	237	309	381	453	525	597	669	813	957
		Low	297	333	369	405	441	477	513	549	585	657	729
28'	19'-10"	High	308	406	504	602	700	798	896	994	1,092	1,288	1,484
		Low	404	453	502	551	600	649	698	747	796	894	992
32'	22'-8"	High	555	683	811	939	1,067	1,195	1,323	1,451	1,579	1,835	2,091
		Low	528	592	656	720	784	848	912	976	1,040	1,168	1,296
36'	25'-5"	High	835	997	1,159	1,321	1,483	1,645	1,807	1,969	2,131	2,455	2,779
		Low	668	749	830	911	992	1,073	1,154	1,235	1,316	1,478	1,640
40'	28'-3"	High	1,149	1,349	1,549	1,749	1,949	2,149	2,349	2,549	2,749	3,149	3,549
		Low	824	924	1,024	1,124	1,224	1,324	1,424	1,524	1,624	1,824	2,024

## Single-Span Valley Beam (lbs)

House Width	Valley Span	Location	Roof Snow Load (PSF)										
			20 LL 15 DL	25 LL 15 DL	30 LL 15 DL	35 LL 15 DL	40 LL 15 DL	45 LL 15 DL	50 LL 15 DL	55 LL 15 DL	60 LL 15 DL	70 LL 15 DL	80 LL 15 DL
			Valley Beam Reaction (lbs)										
12'	8'-6"	High	247	277	307	337	367	397	427	457	487	547	607
		Low	495	555	615	675	735	795	855	915	975	1,095	1,215
16'	11'-4"	High	440	493	546	600	653	706	760	813	866	973	1,080
		Low	879	986	1,093	1,199	1,306	1,413	1,519	1,626	1,733	1,946	2,159
20'	14'-2"	High	687	770	854	937	1,020	1,104	1,187	1,270	1,354	1,520	1,687
		Low	1,374	1,540	1,707	1,874	2,040	2,207	2,374	2,540	2,707	3,040	3,374
24'	17'-0"	High	989	1,109	1,229	1,349	1,469	1,589	1,709	1,829	1,949	2,189	2,429
		Low	1,978	2,218	2,458	2,698	2,938	3,178	3,418	3,658	3,898	4,378	4,858
28'	19'-10"	High	1,346	1,510	1,673	1,836	2,000	2,163	2,326	2,490	2,653	2,980	3,306
		Low	2,693	3,019	3,346	3,673	3,999	4,326	4,653	4,979	5,306	5,959	6,613
32'	22'-8"	High	1,758	1,972	2,185	2,398	2,612	2,825	3,038	3,252	3,465	3,892	4,318
		Low	3,517	3,944	4,370	4,797	5,224	5,650	6,077	6,504	6,930	7,784	8,637
36'	25'-5"	High	2,226	2,496	2,766	3,036	3,306	3,576	3,846	4,116	4,386	4,926	5,466
		Low	4,451	4,991	5,531	6,071	6,611	7,151	7,691	8,231	8,771	9,851	10,931
40'	28'-3"	High	2,748	3,081	3,414	3,748	4,081	4,414	4,748	5,081	5,414	6,081	6,748
		Low	5,495	6,162	6,828	7,495	8,162	8,828	9,495	10,162	10,828	12,162	13,495

## How to Use These Tables

- Determine the roof snow load in pounds per square foot.
- Locate the **House Width** and the corresponding **Hip** or **Valley Span** that meets or exceeds your application.
- Identify the **High**- and **Low**-end hip member reactions (shown in pounds).
- Where multiple hip/valley members intersect, add the corresponding reactions from each member.
- See page 11 to size posts.

## General Notes

- Tables are based on:
  - Uniform loads.
  - Equal common and jack rafter slopes.
- Interpolation between house widths to determine reactions (and spans) is permitted.
- Member weight is not included.

## Single-Span Hip/Valley

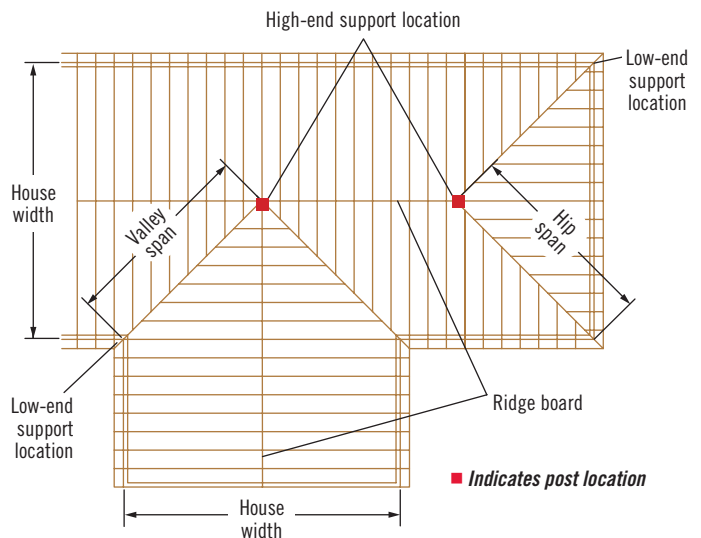

# POST ALLOWABLE LOADS

## Allowable Axial Load (lbs)—115% Roof Snow Load

Post Length	1.3E TimberStrand® LSL Post Size				1.8E Parallam® PSL Post Size		
	2x4 <sup>(1)</sup>		2x6 <sup>(1)</sup>		3½" x 3½"	3½" x 5¼"	5¼" x 5¼"
	1 ply	2 ply <sup>(2)</sup>	1 ply	2 ply <sup>(2)</sup>			
6'	940	4,275	1,470	6,665	11,200	16,800	36,675
7'		3,400		5,310	9,140	13,710	32,545
8'		2,740		4,285	7,550	11,325	28,490
9'		2,250		3,520	6,320	9,480	24,835
10'		1,870		2,930	5,355	8,035	21,695
12'		1,350		2,115	3,980	5,965	16,805
14'					3,065	4,595	13,315

(1) May be angled up to 4" per foot of length.

(2) Two-ply posts to be connected with 10d (0.148" x 3") nails at 6" on-center, alternate sides and stagger.

## MULTIPLE-MEMBER CONNECTIONS

### Fastener Installation Requirements

Piece Width	# of Plies	Fastener				
		Type <sup>(1)</sup>	Min. Length	# Rows	O.C. Spacing	Location
1½" or 1¾"	2	10d nails	3"	3 <sup>(2)</sup>	12"	One side
		12d–16d nails	3¼"	2 <sup>(2)</sup>		
		Screws	3" for 1½" members 3¾" for 1¾" members	2		
	3	10d nails	3"	3 <sup>(2)</sup>	12"	Both sides
		12d–16d nails	3¼"	2 <sup>(2)</sup>		
		Screws	3¾" or 3½"	2		

L6

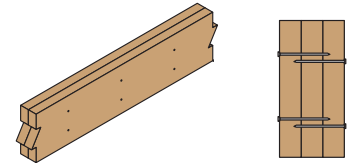

Multiple pieces can be nailed or bolted together to form a header or beam of the required size, up to a maximum width of 5¼". Load must be applied evenly across entire beam width.

For applications that require wider members and/or uneven/side loaded beams, refer to the Trus Joist® Beam, Header and Column Specifier's Guides TJ-9000 or TJ-9020, or contact your Weyerhaeuser representative.

(1) 10d nails are 0.128" diameter; 12d–16d nails are 0.148"–0.162" diameter; screws are SDS, USP WS, TrussLOK® or SDW.

(2) An additional row of nails is required with depths of 14" or greater.

- When fasteners are required on both sides, stagger fasteners on the second side so they fall halfway between fasteners on the first side.

## RAFTER, HIP AND VALLEY ALLOWABLE HOLES

### 1.55E TimberStrand® LSL

Beam Depth	Maximum Round Hole Size
9½"	3"
11¾"	3⅝"
14"	4⅝"

- See illustration for allowed hole zone.

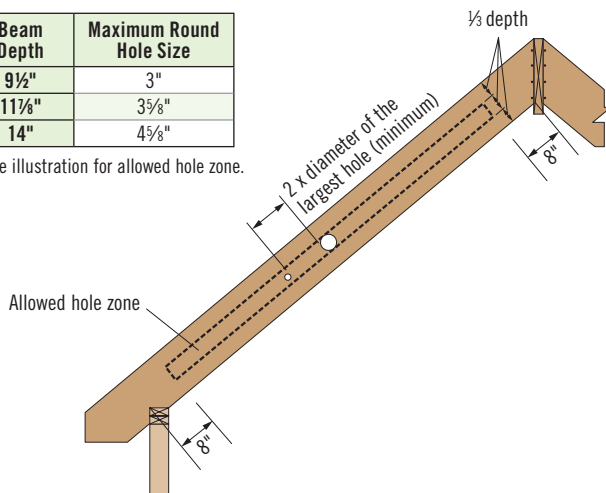

### All Other TimberStrand® LSL and Microllam® LVL Products

Beam Depth	Maximum Round Hole Size
5½"	1¾"
7¼"–18"	2"

- See illustration for allowed hole zone.

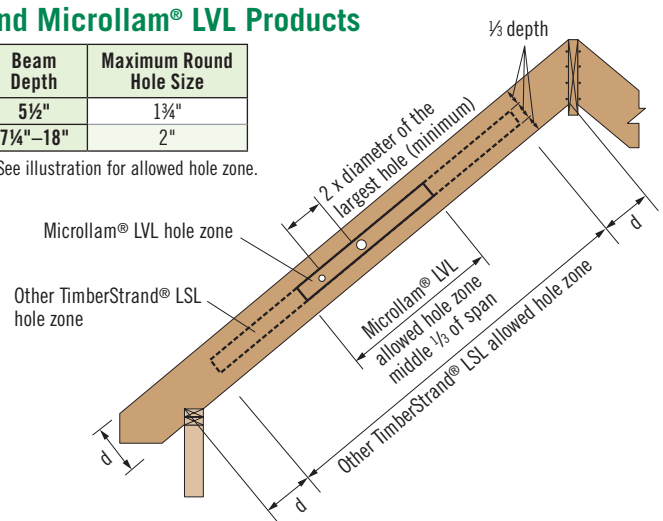

### General Notes

- Round holes only.
- Allowed hole zone suitable for rafters, hips, and valleys with uniform and/or concentrated loads anywhere along the member.



**DO NOT cut, notch, or drill holes in rafters, ceiling joists, hips, or valleys except at birdsmouth cut locations or as indicated in the illustrations and tables above.**

### General Notes

- Allowed hole zone suitable for rafters, hips, and valleys with uniform loads only.
- Round holes only.
- No holes in cantilevers.

**WARNING:** This product can expose you to chemicals including wood dust which are known to the State of California to cause cancer, and methanol, which are known to the State of California to cause birth defects or other reproductive harm. Drilling, sawing, sanding or machining wood products can expose you to wood dust. Avoid inhaling wood dust or use a dust mask or other safeguards for personal protection. For more information go to [www.P65Warnings.ca.gov](http://www.P65Warnings.ca.gov) and [www.P65Warnings.ca.gov/wood](http://www.P65Warnings.ca.gov/wood).

# TYPICAL ROOF SYSTEM

Lateral blocking may be required (for clarity, lateral blocking is not shown here). See details R21 and R22.

**WARNING**  
Rafters and joists are unstable until laterally braced. Lack of proper bracing or insufficient roof system design can result in serious accidents.

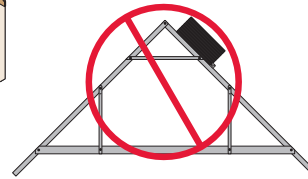
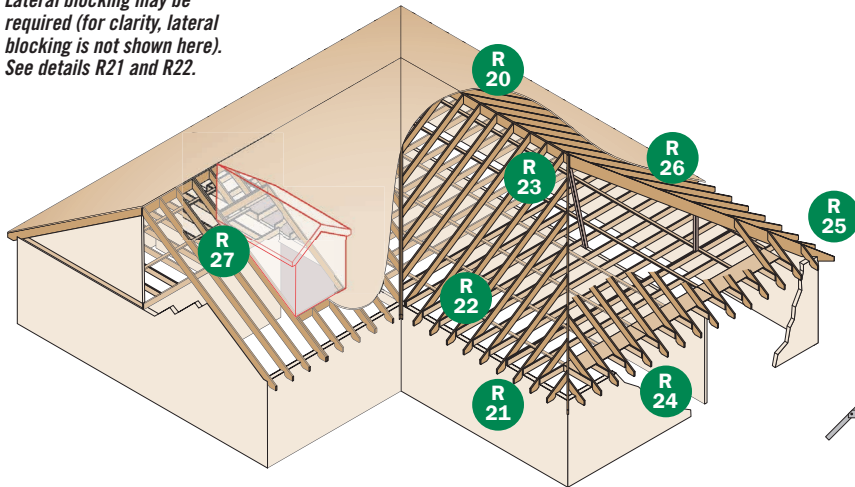

DO NOT stack building materials on unsheathed joists or rafters.



DO NOT walk on joists or rafters until braced. INJURY MAY RESULT.

## ROOF FRAMING DETAILS

### Ridge Connection

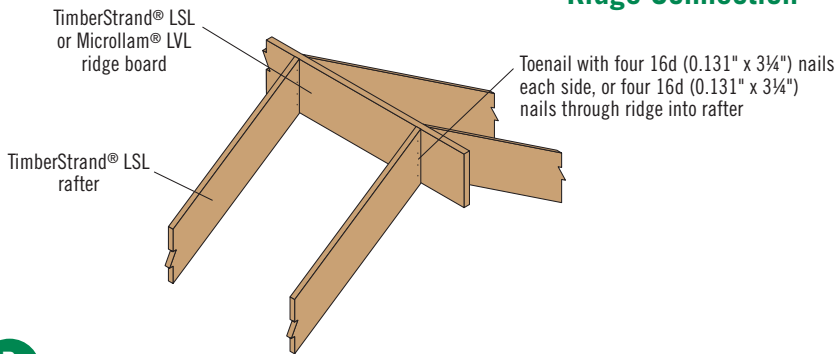

### Minimum Ridge Board Depth

Rafter Size	Rafter Pitch		
	4:12 to 9:12	10:12 to 11:12	12:12
	Ridge Board Sizes		
2x6	2x8	2x10	2x10
2x8	2x10	2x12	2x12
2x10	14"	14"	14"
2x12	14"	16"	16"

R 20

Additional connections may be required to resist wind forces in high wind zones.

### Heel Connection (Lap)

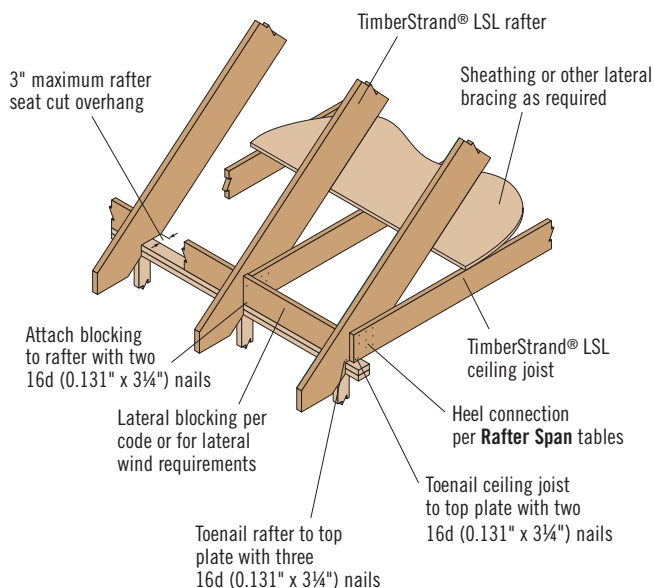

R 21

### Heel Connection (Platform)

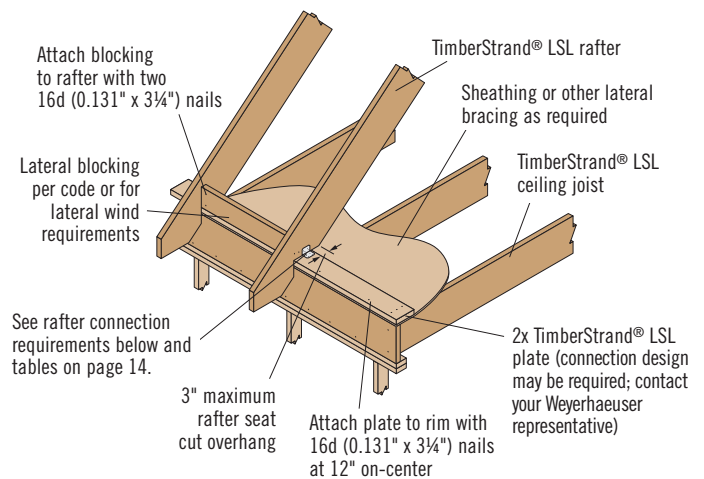

R 22

#### Rafter Connection for Thrust:

- Addresses lateral load only, not intended for wind uplift.
- See **Rafter Span** tables (pages 4–7) to find the nail quantity required for a lap connection. See detail R21.
  - If fewer than 8 nails are required, use one A23 or A3 clip, each side.
  - If 8–15 nails are required, use two A23 or A3 clips, each side.

## Hip/Ridge/Valley Post Detail

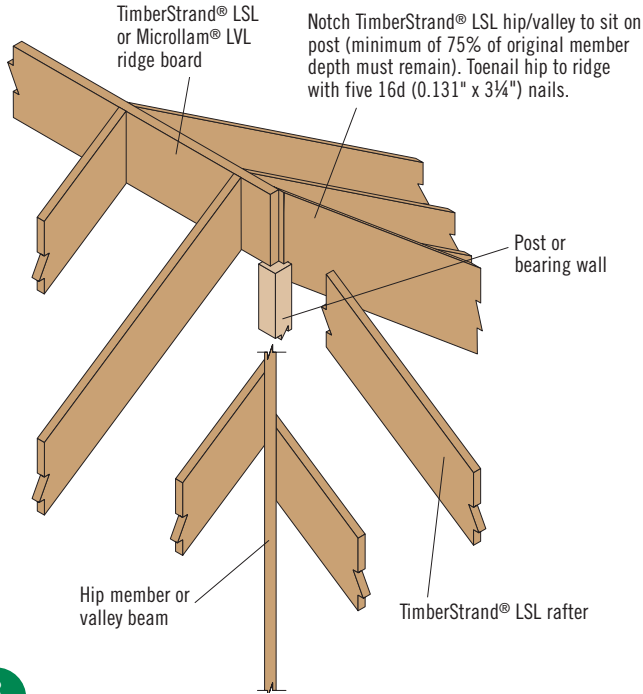

R 23

## Outlooker Detail

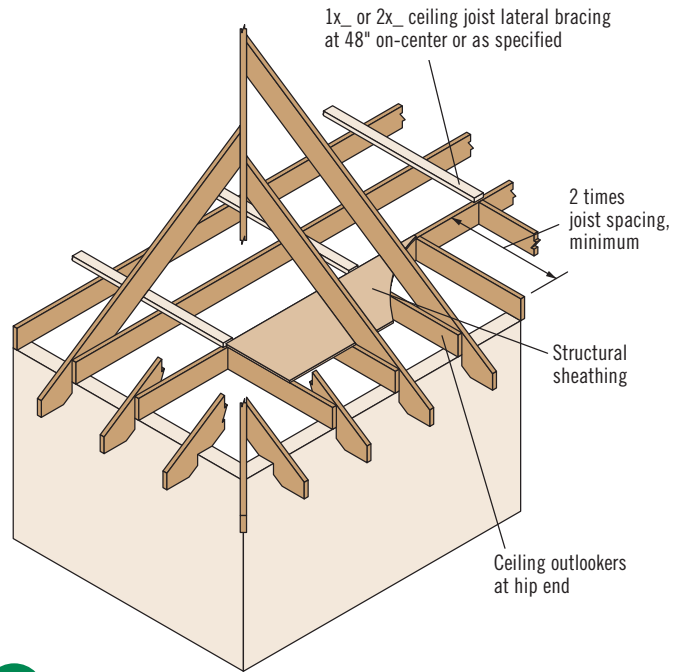

R 24

## Hip/Valley Low End

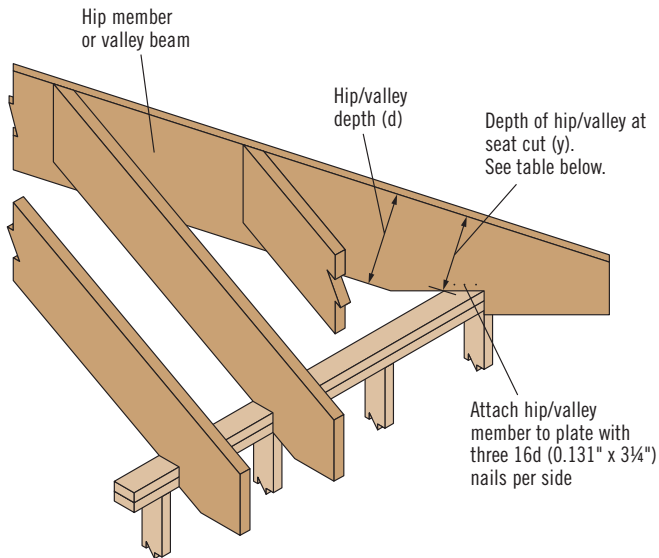

### Hip/Valley Depth

Minimum Percentage of Original Hip/Valley Depth Required		
Member Type	TimberStrand® LSL	Microllam® LVL
Hip member	35% <sup>(1)</sup>	50%
Valley beam	60%	90%

- (1) For net width greater than 3", minimum percentage is 30%.  
 ▪ Calculate percentage as  $y/d \times 100$ .

R 25

## Hip/Valley Intermediate Support

Connect rafter to hip with five 16d (0.131" x 3/4") nails. For rafter-to-valley connection, see table below.

Four 16d (0.131" x 3/4") nails at each end of strap/cleat

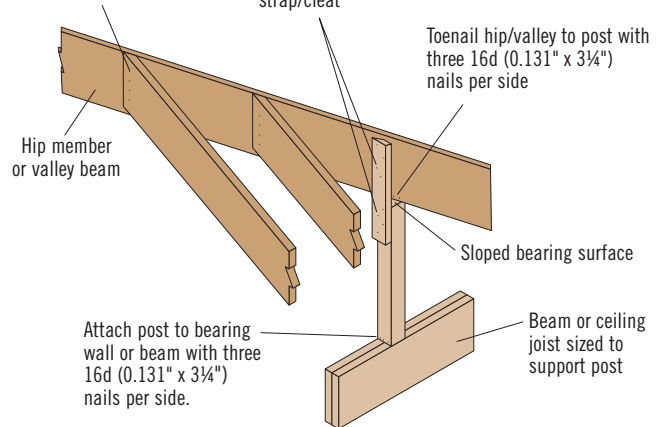

Attach post to bearing wall or beam with three 16d (0.131" x 3/4") nails per side.

Beam or ceiling joist sized to support post

### Rafter-to-Valley Connection

Rafter On-Center Spacing	Rafter Span	Roof Snow Load		
		30 LL + 15 DL	50 LL + 15 DL	80 LL + 15 DL
Number of 16d (0.131" x 3/4") Nails Required				
16"	6'	5	5	5
	12'	5	6	8
	18'	6	9	12
	24'	8	12	*
24"	6'	5	5	7
	12'	6	8	11
	18'	9	13	*
	24'	12	*	*

\* Contact your Weyerhaeuser representative for additional connection information.

R 26

# ROOF FRAMING DETAILS

## Dormer Framing

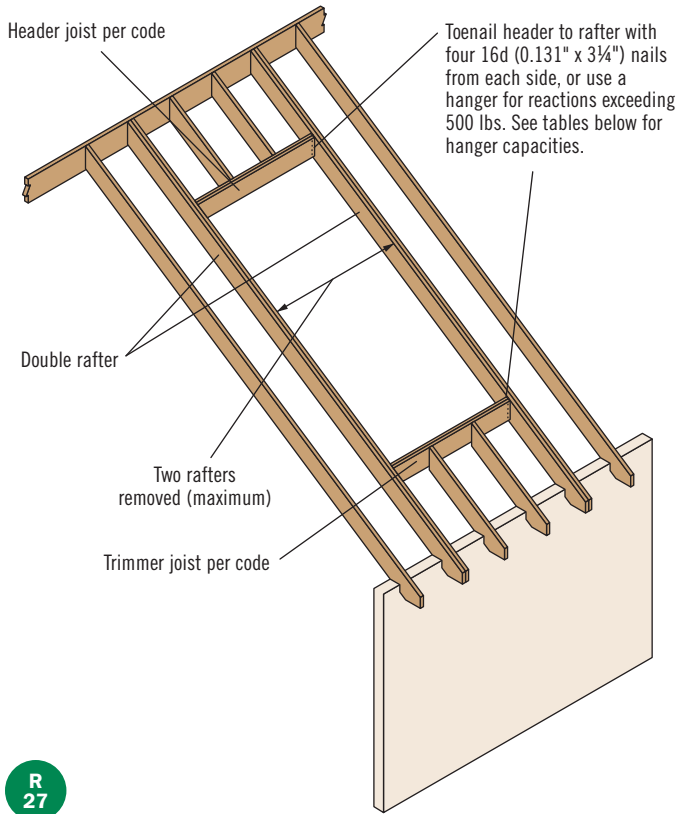

R 27

## Valley-to-Hip Connection

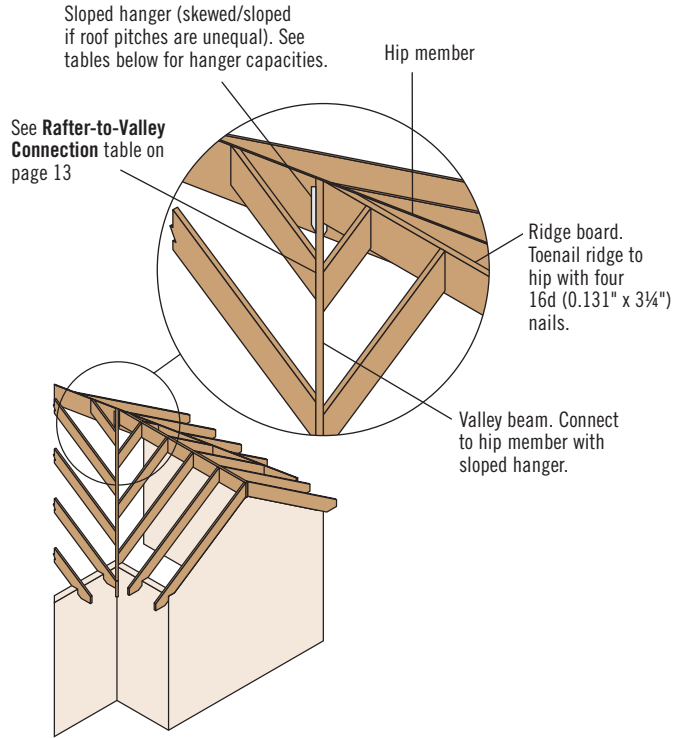

R 28

Contact your Weyerhaeuser representative for proper sizing of a hip or valley with a point load.

# FRAMING CONNECTORS

## Face Mount Hangers (Detail R27)

Hanger Type	Dormer/Trimmer Header	Depth	Hanger	Capacity (lbs)	Nailing	
					Double Rafter	Dormer Header
Simpson Strong-Tie®	1 1/2"	5 1/2"–7 1/4"	LUS26	990	10d	10d
		9 1/4"–11 1/4"	LUS210	1,530	10d	10d
	2-ply 1 1/2"	5 1/2"–7 1/4"	LUS26-2	1,170	16d	16d
		9 1/4"–11 1/4"	LUS210-2	2,075	16d	16d
USP Structural Connectors®	1 1/2"	5 1/2"–7 1/4"	JUS26	1,000	10d	10d
		9 1/4"–11 1/4"	JUS210	1,545	10d	10d
	2-ply 1 1/2"	5 1/2"–7 1/4"	JUS26-2	1,185	16d	16d
		9 1/4"–11 1/4"	JUS210-2	2,105	16d	16d

## Angle Clips (Detail R22)

Hanger Type	Clip	Capacity (lbs)	Nailing	
			Top Plate	Rafter/Ceiling Joist
Simpson Strong-Tie®	A23	535	10d x 1 1/2"	10d x 1 1/2"
USP Structural Connectors®	A3	545	10d x 1 1/2"	10d x 1 1/2"

## Variable Slope/Skew Hangers (Detail R28)

Hanger Type	Hip/Valley	Depth	Hanger	Capacity (lbs)		Nailing	
				Sloped	Sloped and Skewed	Hip	Valley
Simpson Strong-Tie®	1 1/2"	All	LSSJ210LZ <sup>(1)</sup>	810	810	10d	10d x 1 1/2"
			LSSJ210RZ <sup>(1)</sup>				
	2-ply 1 1/2"	All	LSSR210-2Z	2,365	1,810	16d	10d x 1 1/2"
			LSSR1.81Z	1,565	1,205	10d	10d x 1 1/2"
USP Structural Connectors®	1 1/2"	All	LSSH210	1,380	1,380	10d	10d x 1 1/2"
			LSSH31	3,045	1,610	16d	10d x 1 1/2"
	2-ply 1 1/2"	All	LSSH179	1,380	1,380	10d	10d x 1 1/2"
			LSSH35	3,045	1,610	16d	10d x 1 1/2"

(1) LSSJ210RZ = skewed right, LSSJ210LZ = skewed left.

- LSSJ, LSSR and LSSH hangers can be field adjusted for slopes and skews of up to 45°. Additional lateral restraints are required for 16" and 18" members.

## General Notes

- For additional information, please refer to Simpson Strong-Tie® and USP Structural Connectors® literature.
- Fill all round and positive-angle nail holes with the proper nails.
  - 10d x 1 1/2" nails are 0.148" diameter by 1 1/2" long
  - 10d nails are 0.148" diameter by 3" long
  - 16d nails are 0.162" diameter by 3 1/2" long
- All capacities are for downward loads at 115% load duration.
- Hangers to be supported by headers of TimberStrand® LSL, Microllam® LVL, Parallam® PSL, Douglas fir, or southern pine.

## Roof Plan

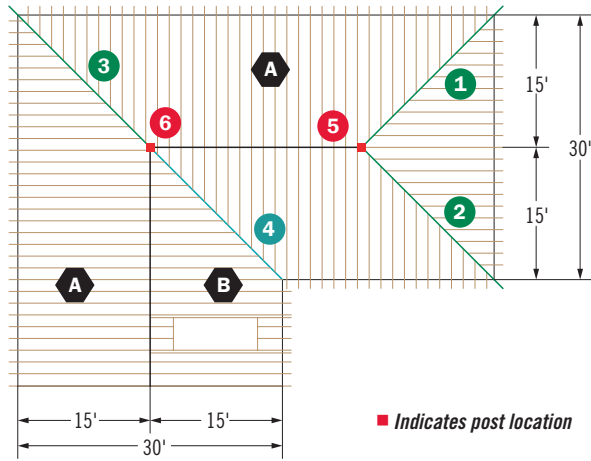

## Ceiling Plan

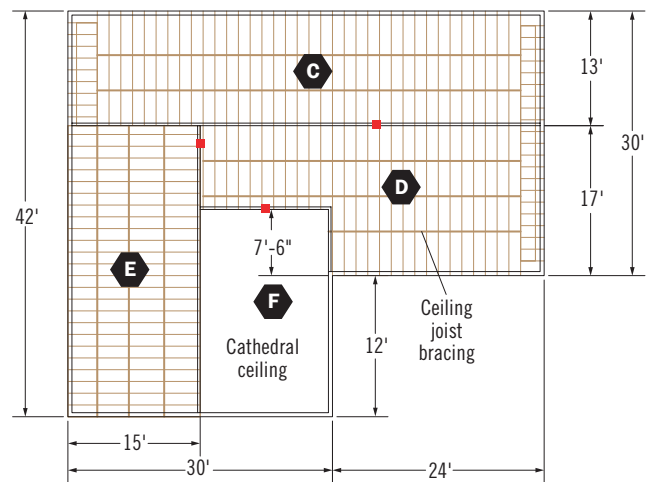

### Roof Plan

- One-story, single-family residence
- Roof slope = 8:12
- Roof snow load = 40 psf
- Dead load = 10 psf non-ceiling, 15 psf ceiling
- Unfinished attic area
- Architectural grade fiberglass shingles
- On-center spacing = 16" (preferred)

### 1 Determine Rafter Size and Heel Connection Requirements

**Roof Plan, area A** (limited access attic area):

- Find allowable member in the **Rafter Span and Heel Connection Tables, No Directly Applied Ceiling** on pages 4 and 5.
  - At 16" on-center spacing with a 40 LL + 10 DL snow load, a 1½" x 9½" 1.5E TimberStrand® LSL rafter will span 17'-5".
  - For an 8:12 roof slope, nine 16d (0.131" x 3¼") nails are required at the heel joint. See detail R21.
- See details R20 and R26 for required rafter-to-ridge and rafter-to-valley connections.

**Roof Plan, area B** (includes cathedral ceiling):

- Find allowable member in the **Rafter Span and Heel Connection Tables, Directly Applied Ceiling** on pages 6 and 7.
  - At 16" on-center spacing with a 40 LL + 15 DL snow load, a 1½" x 9½" 1.5E TimberStrand® LSL rafter will span 15'-8".
  - For an 8:12 roof slope, nine 16d (0.131" x 3¼") nails are required at the heel joint.
- See details R20 and R26 for required rafter-to-ridge and rafter-to-valley connections.

### 2 Size Hip Members

- Find hip and valley beam spans using the **Rafter-to-Hip/Valley Span** table on page 8.
  - A 15' rafter span converts to a 21'-3" hip or valley span.

**Hip Members 1, 2, and 3** (identical spans and loading):

- Find allowable member in the **Single-Span Hip Members** table on page 8.
  - Both a 2-ply, 1½" x 11⅞" 1.5E TimberStrand® LSL member (23'-5") and a 1-ply, 1¾" x 14" 1.55E TimberStrand® LSL member (23'-6") will work.
  - Use the single ply, which costs less and is easier to install.
- See details R23 and R25 for connections and seat cut.

### 3 Size Valley Beam

**Valley Beam 4** (use valley beam tables only):

- Find allowable member in the **Single-Span Valley Beams** table on page 9.
  - A 3-ply, 1¾" x 14" 1.55E TimberStrand® LSL valley beam (22'-11") will work.
- See details R23 and R25 for connections and seat cut.

### 4 Size Support Posts

- Calculate post lengths for posts 5 and 6: Rafter span (15') x roof slope (8:12) = 10'.

**Post 5:**

- Calculate post load using the **Single-Span Hip Member** reaction table on page 10. The high-end reaction for a 32' house width (30' rounded up) is 1,067 lbs. Both hip members 1 and 2 transfer load to post 5, so the post reaction is  $2 \times 1,067 = 2,134$  lbs.
- Find allowable member using the **Allowable Axial Load** table on page 11.
  - The allowable axial load capacity for a 10', 2-ply, 2x6 1.3E TimberStrand® LSL post (2,930 lbs) is greater than 2,134, so the post is adequate.
- Check connection requirements; see detail R26 on page 13. The post may be angled up to 4" per foot of length; therefore, install the low end of the post directly over the bearing wall, 2' from the ridge line.

**Post 6:**

- Post member 6 receives loads from both hip member 3 (reaction = 1,067 lbs, from above) and valley beam 4.
- Find the reaction of valley beam 4.
  - In the **Single-Span Valley Beam** reaction table on page 10, the high end reaction is 2,612 lbs.
  - Total reaction on post 6 is 3,679 lbs (2,612 + 1,067).
- In the **Allowable Axial Load** table on page 11, a 10', 3½" x 3½" 1.8E Parallam® PSL post (5,355 lbs) is adequate.

### 5 Size Ceiling Joists

- Use design loads of 20 LL and 10 DL for an unfinished attic area with limited access. Specify 16" on-center joist spacing to match the roof rafter spacing, and refer to the **Ceiling Joists** table on page 3.
  - A 1½" x 7¼" 1.5E TimberStrand® LSL ceiling joist can span 15'-7", which is adequate for areas C and E. A 1½" x 9½" 1.5E TimberStrand® LSL ceiling joist can span 20'-5", which is adequate for the 17' span portion of ceiling area D. Connect to rafter per **Rafter Span and Heel Connection** tables.
- The cathedral ceiling in area F is within the limits of this guide because the room area is less than 320 ft<sup>2</sup> (15' x 19.5' = 293 ft<sup>2</sup>) and takes up less than 15% of the total ceiling area (293 / (42 x 30 + 24 x 30) = 14.8%).

# WE CAN HELP YOU BUILD SMARTER

You want to build solid and durable structures—we want to help. Weyerhaeuser provides high-quality building products and unparalleled technical and field assistance to support you and your project from start to finish.

**Floors and Roofs:** Start with the best framing components in the industry: our Trus Joist® TJI® joists; TimberStrand® LSL rim board; and TimberStrand® LSL, Microllam® LVL, and Parallam® PSL headers and beams. Pull them all together with our self-gapping and self-draining Weyerhaeuser Edge Gold™ floor panels and durable Weyerhaeuser roof sheathing.

**Walls:** Get the best value out of your framing package—use TimberStrand® LSL studs for tall walls, kitchens, and bathrooms, and our traditional, solid-sawn lumber everywhere else. Cut down installation time by using TimberStrand® LSL headers for doors and windows, and Weyerhaeuser wall sheathing with its handy two-way nail lines.

**Software Solutions:** Whether you are a design professional or lumber dealer, Weyerhaeuser offers an array of software packages to help you specify individual framing members, create cut lists, manage inventories—even help you design a complete structural frame. Contact your Weyerhaeuser representative to find out how to get the software you need.

**Technical Support:** Need technical help? Weyerhaeuser has one of the largest networks of engineers and sales representatives in the business. Call us for help, and a skilled member from our team of experts will answer your questions and work with you to develop solutions that meet all your structural framing needs.



## LIMITED LIFETIME PRODUCT WARRANTY

Weyerhaeuser provides a limited warranty for the expected life of the structure for all Trus Joist® branded products. Product information, installation instructions, and the full text of each product's limited warranty (including limitations and exclusions) are available on the Weyerhaeuser website, from your Weyerhaeuser representative, or by calling toll free: 888-453-8358.

Additionally, Weyerhaeuser offers limited warranties on a broad variety of its other products. To see complete details of all Weyerhaeuser product warranties, visit [weyerhaeuser.com/woodproducts/warranty](http://weyerhaeuser.com/woodproducts/warranty).

1.888.453.8358    [WEYERHAEUSER.COM/WOODPRODUCTS](http://WEYERHAEUSER.COM/WOODPRODUCTS)



Revised 11/2019 December 2019. Weyerhaeuser and Trus Joist are registered trademarks of Weyerhaeuser LLC. © 2019 Weyerhaeuser NR Company. All rights reserved.

## CONTACT US

**1.888.453.8358** • [weyerhaeuser.com/woodproducts/contact](http://weyerhaeuser.com/woodproducts/contact)

Contact your local representative or dealer at:

Visit [weyerhaeuser.com/woodproducts/warranty](http://weyerhaeuser.com/woodproducts/warranty) for copies of this and other Trus Joist® Engineered Wood Product warranties.

**January 2020 • Reorder TJ-9005**

This document supersedes all previous versions. If this is more than one year old, contact your dealer or Weyerhaeuser rep.

Weyerhaeuser, Microllam, Parallam, TimberStrand, and Trus Joist are registered trademarks and Edge Gold is a trademark of Weyerhaeuser NR. © 2020 Weyerhaeuser NR Company. All rights reserved. Printed in the USA.