

NEW YORK STATE



STEEL CONSTRUCTION MANUAL

4TH EDITION

ANDREW M. CUOMO
GOVERNOR

PAUL KARAS
ACTING COMMISSIONER

Department of Transportation, Office of Structures
January 2018

NEW YORK STATE

STEEL CONSTRUCTION MANUAL

4TH Edition

**NEW YORK STATE DEPARTMENT OF TRANSPORTATION
ENGINEERING DIVISION
OFFICE OF STRUCTURES**

**RICHARD MARCHIONE
DEPUTY CHIEF ENGINEER STRUCTURES**

PREPARED BY THE METALS ENGINEERING UNIT

January 2018

STEEL CONSTRUCTION MANUAL
LIST OF SECTIONS

<u>Section</u>	<u>Title</u>
1	Introduction
2	Drawings
3	Inspection
4	General Fabrication Requirements
5	Base Metal
6	Preparation of Base Metals
7	Welding
8	Qualification
9	Fracture Control Plan
10	Bolting
11	Shop Assembly
12	Dimensional Tolerances for Fabricated Members
13	Cleaning and Protective Coatings
14	Storage, Transportation, & Erection
15	Heat Curving, Cambering, and Straightening
16	Radiographic Testing
17	Ultrasonic Testing
18	Magnetic Particle Inspection
19	Dye Penetrant Inspection

TABLE OF CONTENTS

SECTION 1 INTRODUCTION	1
SECTION 2 DRAWINGS	3
201. CONTRACT DRAWINGS	3
201.1 Definition	3
201.2 Requests for Clarification	3
201.3 Dimensions	3
201.4 Errors.....	3
201.5 Principal Controlling Dimensions and Material Properties	3
202. SHOP DRAWINGS.....	4
202.1 Preparation	4
202.2 Type and Size.....	4
202.3 Project Information Required on Shop Drawings.....	4
202.4 NYSDOT Review of Shop Drawings	5
202.5 Shop Drawing Submittal Procedure.....	6
202.6 Vacant	7
202.7 Vacant	7
202.8 Revisions.....	7
202.9 Distribution of Approved Shop Drawings	7
202.10 Archiving	7
202.11 Submittal to Railroad Companies and Other Agencies	7
202.12 Contractor’s Responsibility	8
202.13 Detention of Shop Drawings.....	8
202.14 Consultant Engineering Review	9
202.15 Cost of Shop Drawing Prints/ Reproducibles and Microfilm.....	9
203. DETAILING REQUIREMENTS FOR SHOP DRAWINGS.....	9
203.1 AASHTO Requirements	9
203.2 AREMA Requirements	9
203.3 Detailing for Welded Fabrication	9
203.4 Girder Details.....	10
203.5 Field Splices in Stringers and Girders	10
203.6 Location of Shop Welded Splices in Fabricated Members.....	11
203.7 Vacant	11
203.8 Vacant	11
203.9 Longitudinal Stiffeners	11
203.10 Lateral Bracing and Diaphragm Connections.....	13
203.11 Bearing Sole Plates	13
203.12 Curved Girders.....	13
203.13 Bolt Spacing and Edge Distance.....	13
203.14 Seal Spacing.....	14
203.15 Shop Drawing Requirements for Multi-Dimensional Framing with Numerically Controlled Drilling.....	14
204. ERECTION DRAWINGS	14
204.1 General.....	14

204.2	Required Information [Drawings].....	15
204.3	Required Information [Calculations]	15
205.	REPAIR PROCEDURE DRAWINGS	17
205.1	General.....	17
205.2	Required Information.....	17
206.	TRANSPORTATION CONFIGURATION AND DRAWINGS.....	17
206.1	General.....	17
206.2	Required Information.....	17
207.	HEAT CURVING DRAWINGS	18
207.1	General.....	18
SECTION 3 INSPECTION		19
301.	GENERAL.....	19
302.	QUALIFICATION OF INSPECTORS	19
303.	RESPONSIBILITIES OF INSPECTORS	20
303.1	General.....	20
303.2	Inspection of Materials	20
303.3	Inspection of Welding Procedure, Qualification and Equipment	20
303.4	Inspection of Welder, Welding Operator and Tacker Qualifications	21
303.5	Inspection of Work and Records.....	21
303.6	Photographs and Drawings	21
303.7	QA Inspector's Mark of Acceptance for Shipment.....	21
303.8	Report of Shipment of Structural Material (Form B and GC 4b).....	22
303.9	Shipment of Rejected Material or Material Not Offered for Shop Inspection	22
304.	FACILITIES FOR INSPECTION	22
305.	INSPECTOR'S AUTHORITY	22
306.	OBLIGATIONS OF THE CONTRACTOR.....	23
307.	NONDESTRUCTIVE TESTING.....	23
307.1	General.....	23
307.2	Personnel Qualification.....	23
308.	MILL AND SHOP INSPECTION.....	24
SECTION 4 GENERAL FABRICATION REQUIREMENTS		25
401.	FABRICATOR REQUIREMENTS	25
401.1	General Requirements.....	25
401.2	DCES Approval	25
402.	MINIMUM SHOP FACILITIES FOR FABRICATION	25
403.	ORDERING OF MATERIALS.....	26
404.	COMMENCEMENT OF SHOP WORK.....	27
405.	FABRICATION BY GENERAL CONTRACTORS ON REHABILITATION PROJECTS	27
SECTION 5 BASE METAL.....		29
501.	GENERAL.....	29
502.	APPROVED BASE METALS	29
502.1	Specifications.....	29
502.2	Additional Requirements	29
503.	STEEL FOR PINS, ROLLERS AND EXPANSION ROCKERS	30

504.	BACKING, EXTENSION BARS, AND RUN OFF PLATES	30
504.1	Backing	30
504.2	Extension Bars and Run Off Plates.....	30
505.	INTERNAL SOUNDNESS OF PLATES AND SHAPES.....	30
505.1	Laminar Defects at Edges and Ends	30
505.2	Laminar Defects at Tension Groove Welds.....	30
506.	STRAIGHTENING MATERIAL PRIOR TO FABRICATION.....	31
507.	DIRECTION OF ROLLING	32
508.	IDENTIFICATION OF MATERIAL.....	32
SECTION 6 PREPARATION OF BASE METALS.....		35
601.	CUTTING – GENERAL	35
602.	THERMAL CUTTING OF A709 STEELS (50,000 psi minimum yield strength or higher).....	35
603.	SURFACES AND EDGES TO BE WELDED	35
604.	FLANGE PLATES	36
605.	WEB PLATES	36
606.	TRUSS MEMBERS.....	36
607.	STIFFENERS AND CONNECTION PLATES	36
608.	LATERAL GUSSET PLATES.....	36
609.	SPLICE PLATES AND GUSSET PLATES	36
610.	VACANT.....	36
611.	BENDING OF STRUCTURAL STEEL PLATES.....	37
612.	MACHINING OF CONTACT SURFACES	37
612.1	Bearing Surfaces	37
612.2	Abutting Joints	37
612.3	End Connection Angles	38
613.	BOLT HOLES IN STEEL MEMBERS	38
613.1	General.....	38
613.2	Bolt Holes in Primary Members	40
613.3	Bolt Holes in Primary Members	41
614.	BOLT HOLES IN SECONDARY MEMBERS AND COMPONENTS	41
614.1	General.....	41
614.2	Size of Holes in Secondary Members.....	41
615.	PINS AND ROLLERS	41
615.1	General.....	41
615.2	Boring Pin Holes.....	41
615.3	Pin Clearances.....	41
615.4	Pin Threads	42
615.5	Pilot and Driving Nuts	42
616.	BRONZE SURFACED EXPANSION BEARINGS	42
SECTION 7 WELDING Part A – Design of Welded Connections.....		43
SECTION 7 WELDING Part B – Workmanship and Technique.....		45
704.	GENERAL.....	45
705.	APPROVED WELDING PROCESSES.....	47
706.	FILLER METAL REQUIREMENTS	47

706.1	General.....	47
706.2	Requirements for Weathering Steels	47
706.3	Manufacturer’s Certification.....	47
707.	WELDING WEATHERING STEELS.....	48
708.	PREHEAT AND INTERPASS TEMPERATURE	48
708.1	General Requirements.....	48
708.2	Preheating for Tack Welding	48
709.	HEAT INPUT REQUIREMENT FOR A709-50W (A588) AND A709-HPS70W STEELS	49
710.	STRESS RELIEF HEAT TREATMENT.....	50
711.	REQUIREMENTS FOR MANUAL SHIELDED METAL ARC WELDING	51
711.1	Electrodes for Manual Shielded Metal Arc Welding.....	51
711.2	Procedures for Manual Shielded Metal Arc Welding.....	51
711.2.1	General.....	51
711.2.2	Size of Electrodes	51
711.2.3	Size of Weld Passes.....	51
711.2.4	Direction of Welding.....	52
711.2.5	Gouging Root of Weld	52
711.2.6	Restrictions	52
711.2.7	Field Welding	52
712.	REQUIREMENTS FOR SUBMERGED ARC WELDING	52
712.1	General.....	52
712.2	Electrodes and Fluxes for Submerged Arc Welding.....	53
712.3	Procedures for Submerged Arc Welding with a Single Electrode.....	54
712.4	Procedures for Submerged Arc Welding with Parallel Electrodes.....	54
712.5	Procedures for Submerged Arc Welding with Multiple Electrodes	55
713.	REQUIREMENTS FOR FLUX CORED AND GAS METAL ARC WELDING.....	57
713.1	Electrodes.....	57
713.2	Procedures for FCAW and GMAW.....	57
714.	EXTENSION BARS AND RUNOFF PLATES	58
715.	GROOVE WELD BACKING	58
715.1	Bridge Structures	58
715.2	Buildings and Tubular Structures	58
716.	TEMPORARY AND TACK WELDS.....	58
717.	CONTROL OF DISTORTION AND SHRINKAGE STRESSES.....	59
718.	PEENING	59
719.	ARC STRIKES	60
720.	CAULKING.....	60
721.	WELD CLEANING.....	60
721.1	In Process Cleaning.....	60
721.2	Cleaning of Completed Welds	60
722.	WELD PROFILES AND FILLET WELD SIZES	60
723.	QUALITY OF WELDS (Bridges).....	62
723.1	Visual Inspection	62
723.2	Other Nondestructive Inspection	62

723.3	Limits of Porosity	64
724.	QUALITY OF WELDS (Buildings).....	64
725.	REPAIRS	64
725.1	General.....	64
725.2	Written Repair Procedures.....	65
725.3	Methods of Repair.....	65
SECTION 7 WELDING Part C – Stud Welding.....		66
SECTION 7 WELDING Part D – Welding of Reinforcing Steel		73
735.	GENERAL.....	73
736.	BASE METAL.....	73
737.	WELD PROCESSES	73
738.	FILLER METAL	73
739.	PERMISSIBLE STRESSES	73
740.	EFFECTIVE DESIGN DIMENSIONS	74
740.1	Direct Butt Splices	74
740.2	Flare-Bevel and Flare-V-Groove Welds.....	74
741.	JOINT DETAILS.....	75
741.1	General.....	75
741.2	Direct Butt Splice Details	75
741.3	Indirect Butt Splice Details.....	76
741.4	Direct Lap Splice Details	76
741.5	Indirect Lap Splice Details.....	76
742.	PREHEAT AND INTERPASS TEMPERATURES	81
743.	PREPARATION OF MATERIAL	82
744.	ASSEMBLY	82
745.	QUALITY OF WELDS.....	82
746.	QUALIFICATION	83
747.	INSPECTION	83
SECTION 8 QUALIFICATION Part A – Welding Procedure Qualification		85
801.	GENERAL.....	85
802.	BASE METAL AND ITS PREPARATION	90
803.	TEST POSITIONS.....	90
804.	TEST SPECIMENS	90
805.	LIMITATION OF VARIABLES	95
805.1	Submerged Arc Welding.....	95
805.2	Flux Cored and Gas Metal Arc Welding	95
806.	METHOD OF TESTING SPECIMENS.....	95
807.	TEST RESULTS.....	96
807.1	Reduced Section Tension Tests	96
807.2	Side Bend Tests.....	96
807.3	All Weld Metal Tension Test.....	96
807.4	Charpy V-Notch Impact Test.....	96
807.5	Chemical Analysis	96
807.6	Radiographic Test.....	96
807.7	Macroetch Specimen.....	96

808.	RETESTS.....	96
808.1	General.....	96
808.2	Impact Specimens.....	96
808.3	Test Plates.....	97
SECTION 8 QUALIFICATION Part B Welder, Welding Operator, and Tacker Qualification..		98
809.	GENERAL.....	98
810.	TEST POSITIONS.....	98
810.1	Groove Welds.....	98
810.2	Fillet Welds.....	99
811.	WELDER QUALIFICATION.....	104
811.1	Welder’s Classification.....	104
811.2	Tests Required.....	104
811.3	Position Qualified.....	107
811.4	Welding Procedure.....	108
811.5	Preparation of Test Specimens.....	108
811.6	Method of Testing Specimens.....	108
811.7	Test Results.....	109
811.8	Retests.....	109
811.9	Period of Effectiveness.....	109
811.10	Records.....	109
812.	WELDING OPERATOR QUALIFICATION.....	110
812.1	Tests Required.....	110
812.2	Welding Procedure.....	113
812.3	Preparation of Test Specimens.....	113
812.4	Method of Testing Specimen.....	113
812.5	Test Results.....	113
812.6	Retests.....	113
812.7	Period of Effectiveness.....	113
812.8	Records.....	113
813.	TACKER QUALIFICATION.....	113
813.1	Tests Required.....	113
813.2	Positions Qualified.....	115
813.3	Welding Procedure.....	115
813.4	Method of Testing Specimens.....	115
813.5	Test Results Required.....	115
813.6	Retests.....	116
SECTION 9 FRACTURE CONTROL PLAN.....		117
901.	GENERAL.....	117
902.	SHOP DRAWING REVIEW.....	117
903.	FABRICATOR QUALIFICATION.....	117
904.	BASE METAL REQUIREMENTS.....	118
904.1	General.....	118
904.2	Toughness Requirements.....	118
904.3	Blast Cleaning & Visual Inspection.....	118
904.4	Repairs to Base Metal.....	118

905.	WELDING PROCESSES	118
906.	WELDING	118
906.1	General	118
906.2	Preheat and Interpass Temperature	119
906.3	Electrode and Electrode/Flux Requirements	120
906.4	Storage of Electrodes	120
906.5	Storage of Wires and Fluxes	120
906.6	Requirements for Backing and Runoff Plates	120
907.	WELDING PROCEDURE QUALIFICATION	120
907.1	General	120
907.2	Weld Metal Toughness	121
907.3	Groove Welding Procedures	121
907.4	Fillet Welding Procedures	121
908.	QUALIFICATION OF WELDERS, WELDING OPERATORS, AND TACKERS 121	
909.	REPAIR WELDING	124
909.1	General	124
909.2	Types of Repairs	124
909.3	Repair Procedures	125
910.	RADIOGRAPHIC TESTING	126
911.	ULTRASONIC TESTING	126
912.	MAGNETIC PARTICLE INSPECTION	127
913.	DYE PENETRANT INSPECTION	127
914.	VISUAL INSPECTION	127
SECTION 10	BOLTING	128
1000.	GENERAL	128
1001.	HIGH STRENGTH BOLTS, NUTS & WASHERS	128
1001.1	General	128
1001.2	New Structure Applications	128
1001.2.1	Non-Weathering Steel Applications (Shop Painted)	128
1001.2.2	Weathering Steel Applications (Painted or Unpainted)	128
1001.2.3	Galvanized Steel Applications	129
1001.3	Bridge Rehabilitation Applications	129
1001.3.1	Existing Non-Weathering Steel Structures	129
1001.3.2	Existing Weathering Steel Structures	129
1002.	STORAGE AND HANDLING	129
1003.	SAMPLING AND TESTING	129
1004.	INSTALLATION	130
1005.	INSPECTION	131
SECTION 11	SHOP ASSEMBLY	135
1101.	ASSEMBLY OF SHOP WELDED CONNECTIONS	135
1101.1	Welded Joint Fit-up	135
1101.2	Assembly of Stiffeners	135
1101.3	Attachment of Bearing Assemblies	136
1102.	SHOP ASSEMBLY OF FIELD WELDED CONNECTIONS	136

1103.	SHOP ASSEMBLY OF BOLTED CONNECTIONS	136
1103.1	General	136
1103.2	Support of Members During Assembly	136
1103.3	Minimum Assembly & Hole Preparation Requirements	136
1103.3.1	Splices in Simply Supported Stringers and Girders	137
1103.3.2	Splices in Continuous Stringers and Girders.....	137
1103.3.3	Connections in Railroad Thru Girders	137
1103.3.4	Connections in Trusses.....	137
1103.3.5	Splices and Connections in Arches	137
1103.3.6	Splices and Connections in Viaduct Structures.....	137
1103.3.7	Splices and Connections in Precision Structures: (Bascule, Lift, Swing, and Suspension Bridges).....	137
1103.4	Assembly Requirements	138
1103.4.1	Full Component Assembly.....	138
1103.4.2	Progressive Component Assembly.....	138
1103.4.3	Full Chord Assembly	138
1103.4.4	Progressive Chord Assembly	138
1103.4.5	Special Complete Structure Assembly	138
1103.5	Reaming to a Template	138
1103.6	Computer Numerically Controlled (CNC) Drilling.....	139
1103.6.1	Quality Control and Verification Measures of Line Elements Fabricated Using CNC	139
1103.6.2	Quality Control and Verification Measures of Multidimensional Framing Fabricated Using CNC.....	139
1103.7	Abutting Joints	140
1103.8	End Connection Angles	140
1103.9	Drifting of Holes.....	140
1103.10	Match-Marking	140
1103.11	Field Assembly in Lieu of Shop Assembly	140
1104.	ALIGNMENT OF MEMBERS DURING SHOP ASSEMBLY	141
SECTION 12 DIMENSIONAL TOLERANCES FOR FABRICATED MEMBERS		142
1201.	GENERAL.....	142
1202.	DEVIATION FROM DETAILED LENGTH	142
1203.	DEVIATION FROM DETAILED WIDTH	142
1204.	DEVIATION FROM SPECIFIED DEPTH.....	142
1205.	LOCATION OF WELDED BUTT JOINTS	142
1206.	INTERMEDIATE STIFFENERS.....	142
1206.1	Location	142
1206.2	Deviation from Straightness and Fit of Intermediate Stiffeners	142
1207.	BEARING STIFFENERS.....	142
1207.1	Deviation from Straightness of Bearing Stiffeners	142
1207.2	Ends in Bearing.....	143
1208.	BEARING AT POINTS OF LOADING	143
1209.	WARPAGE AND TILT OF FLANGES	143
1210.	WEB TO FLANGE OFFSET	143

1211.	DEVIATION FROM FLATNESS OF GIRDER WEBS	143
1211.1	Girders with Intermediate Stiffeners and/or Connection Plates	143
1211.2	Girders With No Full-Depth Web Attachments	144
1211.3	Web Flatness at Bolted Ends	144
1212.	DEVIATION FROM STRAIGHTNESS OF WELDED COLUMNS	144
1213.	DEVIATION FROM HORIZONTAL ALIGNMENT.....	144
1214.	DEVIATION FROM SPECIFIED CAMBER	145
1214.1	General.....	145
1214.2	Deviation from Specified Camber of Single Erection Pieces.....	145
1214.3	Deviation from Specified Camber in Assembly	146
1214.4	Deviation from Specified Camber of Erected Steel Bridge Superstructures	146
1215.	DEVIATION FROM VERTICAL ALIGNMENT OF GIRDER WEBS.....	146
1216.	TOLERANCES FOR JOINT FIT-UP IN WELDED CONNECTIONS.....	146
SECTION 13 CLEANING AND PROTECTIVE COATINGS.....		148
1301.	PAINTED STEEL	148
1302.	UNPAINTED WEATHERING STEEL.....	148
1303.	BOLTED SPLICES / CONNECTIONS.....	148
1304.	MACHINED SURFACES.....	149
1305.	GALVANIZED COATINGS	149
SECTION 14 STORAGE, TRANSPORTATION, & ERECTION.....		150
1401.	STORAGE OF MATERIALS	150
1402.	TRANSPORTATION.....	150
1402.1	Marking for Shipping.....	150
1402.2	Shipping	150
1403.	ERECTION OF STRUCTURAL STEEL	150
1403.1	General.....	150
1403.2	Erector Requirements.....	151
1403.3	Falsework.....	151
1403.4	Field Connections	151
1403.5	Repair of Damaged or Misaligned Steel.....	152
1403.6	Field Reaming and Drifting of Holes on New Bridge Projects	152
1403.7	Field Drilling, Reaming and Drifting of Holes on Bridge Rehabilitation Projects	
	152	
1403.7.1	Field Drilling New Steel	152
1403.7.2	Field Drilling Existing Steel.....	153
1403.7.3	Field Reaming and Drifting of Holes.....	153
1403.8	Adjustment of Pin Nuts.....	153
1404.	REMOVAL OF RUST AND STAINS FROM CONCRETE	153
1405.	FIELD INSPECTION.....	153
1406.	FIELD REPAIR	154
SECTION 15 HEAT CURVING, CAMBERING, AND STRAIGHTENING.....		155
1501.	HEAT CURVING ROLLED BEAMS AND WELDED PLATE GIRDERS	155
1501.1	General.....	155
1501.2	Minimum Radius of Curvature	155
1501.3	Camber Increase for Dead Load Deflection Caused by Residual Stresses.....	155

1501.4	Preparation for Heat Curving.....	156
1501.5	Support of Members for Heating.....	156
1501.6	Heating Process and Equipment.....	157
1501.7	Location of Heating Patterns.....	157
1501.8	Heating Patterns and Method of Heating.....	157
1501.9	Heat Measurement.....	158
1501.10	Artificial Cooling.....	158
1501.11	Control of Web and Flange Distortion.....	158
1501.12	Web Cutting for Heat Curved Welded Plate Girders.....	158
1501.13	Rolled Beams with Cover Plates.....	158
1502.	CAMBERING OF ROLLED BEAMS AND HEAT CAMBERING OF WELDED PLATE GIRDERS.....	158
1502.1	General.....	158
1502.2	Cambering of Rolled Beams.....	158
1502.3	Heat Cambering of Welded Plate Girders.....	159
1502.4	Support of Members for Heat Cambering.....	159
1503.	HEAT STRAIGHTENING DAMAGED STRUCTURAL STEEL.....	159
1504.	REPAIRS.....	159
SECTION 16 RADIOGRAPHIC TESTING.....		161
1601.	GENERAL.....	161
1602.	EXTENT OF TESTING.....	161
1602.1	Butt Joints in Primary Tension Members.....	161
1602.2	Web Splices.....	161
1602.3	Field Splices.....	161
1602.4	Repairs.....	161
1602.5	Radiographic Inspection of Welds Subject to Shear or Compression.....	162
1602.6	Extension of Test Area.....	162
1603.	FRAUDULENT RADIOGRAPHS.....	162
1604.	RADIOGRAPHIC PROCEDURE.....	162
1604.1	General.....	162
1604.2	Preparation for Exposure.....	163
1604.2.1	General.....	163
1604.2.2	Film Type.....	163
1604.2.3	Film Size.....	163
1604.2.4	Radiographic Sources.....	163
1604.2.5	Penetrameters.....	163
1604.2.6	Technique.....	164
1604.3	Quality of Radiographs.....	169
1604.4	Density Limitations.....	169
1604.5	Film Identification.....	169
1604.6	Weld Identification.....	170
1605.	EXAMINATION, REPORT, AND DISPOSITION OF RADIOGRAPHS.....	171
1605.1	General.....	171
1605.2	Standards of Acceptance.....	171
1605.2.1	Tension Welds in Bridges.....	171

1605.2.2	Compression and Shear Welds in Bridges	172
1605.2.3	Welds in Buildings	172
1605.2.4	Repair of Discontinuities	172
1605.3	Radiographic Reports and Submission of Radiographs	172
SECTION 17	ULTRASONIC TESTING	177
1701.	GENERAL	177
1702.	EXTENT OF TESTING	177
1703.	PERSONNEL QUALIFICATION	177
1704.	ULTRASONIC EQUIPMENT	177
1704.1	General	177
1704.2	Straight Beam Search Units	178
1704.3	Angle Beam Search Units	178
1705.	REFERENCE STANDARDS	179
1706.	EQUIPMENT QUALIFICATION	182
1706.1	Horizontal Linearity	183
1706.2	Calibrated Gain Control	183
1706.3	Certification	183
1706.4	Internal Reflections	183
1706.5	Search Units	183
1707.	CALIBRATION FOR TESTING	183
1707.1	General	183
1707.2	Calibration for Straight Beam Testing	183
1707.3	Calibration for Angle Beam Testing	183
1708.	TESTING PROCEDURES	184
1708.1	General	184
1708.2	Cleaning	184
1708.3	Couplant	184
1708.4	Testing with Straight Beam Search Units	184
1708.5	Testing With Angle Beam Search Units	185
1709.	PREPARATION AND DISPOSITION OF REPORTS	186
1710.	WITNESSING OF ULTRASONIC TESTS	186
1711.	CALIBRATION OF THE ULTRASONIC UNIT WITH THE IIW OR OTHER APPROVED REFERENCE BLOCKS	188
1711.1	Longitudinal Mode	188
1711.2	Shear Wave Mode (Transverse)	188
1712.	EQUIPMENT QUALIFICATION PROCEDURES	191
1712.1	Horizontal Linearity Procedure	191
1712.2	Vertical Linearity Procedure	191
1712.3	Internal Reflections Procedure	191
1713.	FLAW SIZE EVALUATION PROCEDURES	191
1713.1	Straight Beam Testing	191
1713.2	Angle Beam Testing	191
1714.	SCANNING PATTERNS	191
SECTION 18	MAGNETIC PARTICLE INSPECTION	197
1801.	GENERAL	197

1802.	TESTING PROCEDURES AND EQUIPMENT	197
1802.1	Yoke Technique	197
1802.2	Pole Positioning	198
1803.	WITNESSING OF MAGNETIC PARTICLE TESTS	198
1804.	PREPARATION AND DISPOSITION OF REPORTS	198
1805.	STANDARDS OF ACCEPTANCE	199
SECTION 19	DYE PENETRANT INSPECTION.....	201
1901.	GENERAL.....	201
1902.	TESTING PROCEDURES.....	201
1903.	WITNESSING OF LIQUID (DYE) PENETRANT TESTS	201
1904.	PREPARATION AND DISPOSITION OF REPORTS	201
1905.	STANDARDS OF ACCEPTANCE	201
APPENDIX A	REPAIR OF UNACCEPTABLE FASTENER HOLES.....	1
APPENDIX B	SAMPLE REPAIR DRAWING.....	1
APPENDIX C	GUIDE FOR INDEPENDENT QUALITY ASSURANCE INSPECTORS	1
APPENDIX D	TERMS AND DEFINITIONS	1
APPENDIX E	DESCRIPTION OF COMMON WELD AND BASE METAL DISCONTINUITIES	1
APPENDIX F	SUGGESTED FORMS.....	1
APPENDIX G	ITEMS REQUIRING ARCHIVING	1
APPENDIX H	APERTURE CARDS.....	2
APPENDIX I	ELECTRONIC SUBMISSIONS	1
APPENDIX J	FILE NAMING CONVENTION FOR STEEL SHOP DRAWING.....	1
APPENDIX K	VACANT	1
APPENDIX L	FHWA APPENDIX A1 – A325	1
APPENDIX M	METRIC TABLES	1
APPENDIX N	VACANT	1
APPENDIX O	VACANT	1
APPENDIX P	NYSDOT ULTRASONIC TESTING TECHNICIAN PROGRAM	1

List of Tables

Table	Page No.
505	Visual Inspection and Repair of Edges of Plates and Shapes33
708	Minimum Preheat And Interpass Temperature49
710a	Minimum Holding Time50
710b	Alternative Stress-Relief Heat Treatment51
723	Weld Reinforcement62
742	Minimum Preheat and Interpass Temperatures81
811.3	Welder Qualification – Type and Position Limitations108
904	FCM Toughness Requirement For Base Metal119
906.2	Minimum Preheat and Interpass Temperature For Welding Fracture Critical Members – (Degrees F)119
910	Penetrameter Requirements For Fracture Critical Members126
1001.5a	Bolt Tension..... Vacant
1001.5b	Nut Rotation From Snug Tight Condition Vacant
1003.1	Minimum Bolt Tension.....133
1004.1	Nut Rotation from Snug Tight Condition133
1211.1	Maximum Deviation From Web Flatness For Girders With Intermediate Stiffeners and/or Connection Plates.....142
1211.2	Maximum Deviation From Web Flatness For Girders Without Intermediate Stiffeners, Connection Plates or Other Full Depth Attachments That May Stiffen The Web143
1604.1	Penetrameter Requirements163
1700A	Procedure Chart193
1700B	Highway & Railway Bridges (Tension) Ultrasonic acceptance- rejection criteria195
1700C	Buildings (Compression) Ultrasonic acceptance-rejection criteria196
E1	Common Types of DiscontinuitiesE6
M1	Metric/English Bolt Substitution TableM1
505M	Visual Inspection and Repair of Edges of Plates and Shapes (100m and Under in Thickness).....M2
708M	Minimum Preheat and Interpass TemperatureM3
710aM	Minimum Holding TimeM4
710bM	Alternative Stress-Relief Heat TreatmentM4
723M	Weld ReinforcementM5
742M	Minimum Preheat and Interpass TemperaturesM6
904M	FCM Toughness Requirement For Base MetalM7
906.2M	Minimum Preheat and Interpass Temperature for Welding Fracture Critical Members – (Degrees C).....M8
910M	Penetrameter Requirements For Fracture Critical MembersM9
1001.5aM	Bolt Tension.....M10
1211.1M	Maximum Deviation From Web Flatness For Girders With

	Intermediate Stiffeners and/or Connection Plates.....	M11
1211.2M	Maximum Deviation From Web Flatness For Girders Without Intermediate Stiffeners, Connection Plates or Other Full Depth Attachments That May Stiffen the Web.....	M11
1604.1M	Penetrameter Requirements	M12
1700A M	Procedure Chart	M13
1700B M	Highway & Railway Bridges (Tension) Ultrasonic Acceptance-Rejection Criteria	M14
1700C M	Building (Compression) Ultrasonic Acceptance-Rejection Criteria	M15

List of Figures

Figure	Page No.
202.6A	NYS DOT Preliminary Shop Drawings..... Vacant
202.7A	NYS DOT Signature Approval Shop Drawings Vacant
203.9A	Longitudinal Stiffener at Bolted Splice 12
704	Sample Welding Procedure Specification 46
712.1	Weld Pass Ratio 53
723	Acceptable and Unacceptable Weld Profiles 63
740	Effective Throats For Flare-Groove Welds 75
741.2	Direct Butt Splices 77
741.3	Indirect Butt Splices..... 78
741.4	Direct Lap Splice Details 79
741.5	Indirect Lap Splice..... 80
745	Acceptable and Unacceptable Weld Profiles 83
801a	Sample Welding Procedure Qualification Record..... 87
801b	Complete PQR Test Plate For SAW, GMAW & FCAW 88
801d	Modified PQR Test Plate For SAW, GMAW and FCAW 89
804a	Reduced Section Tension Specimen..... 91
804b	Bend Specimens..... 92
804c	Standard Round All Weld Metal Tension Specimen..... 93
804d	Fillet Weld Soundness Test For Procedure Qualification..... 94
810a	Positions of Groove Welds 100
810b	Positions of Test Plates for Groove Welds 102
810c	Positions of Test Plates for Fillet Welds..... 103
811.2a	Welder Qualification Test Plate – Groove Welds..... 105
811.2b	Optional Welder Qualification Test Plate-Horizontal Position For Shop Welders Only 106
811.2c	Welder Qualification Test Plate – Fillet Welds 107
812.1a	Welding Operator Qualification Test Plate for Automatic Submerged Arc and Automatic Flux Cored Arc Welding..... 111
812.1b	Welding Operator Qualification Test Plate for Electroslag and Electro gas Welding..... 112
813.1	Fillet Weld Break Specimen 114
813.2	Position for Tacker Test Plates 114
813.2	Tacker Qualification – Position Limitations..... 115
813.4	Method of Rupturing Tacker Test Specimen..... 115
907	Procedure Qualification Test Plate (FCM) 122
1001.1	Required Marking for High Strength Fasteners..... 132
1604.2a	Penetrameter Design 166
1604.2b	Radiograph Identification and Penetrameter Locations – Equal Thickness 168
1604.2c	Radiograph Identification and Penetrameter Locations – Unequal Thickness.... 168

1604.6	Permanent Identification of Butt Joints	171
1605a	Limitations of Porosity and Fusion Type Discontinuities in Tension Welds-Bridges.....	174
1605b	Limitation of Porosity and Fusion Type discontinuities in Compression Welds-Bridges.....	175
1605.3	Sample Radiographic Inspection Report	176
1704.3a	Transducer Crystal.....	178
1704.3b	Qualification Procedure of Search Unit Using 11W Reference Block.....	179
1705a	International Institute of Welding (IWW) Ultrasonic Reference Blocks	180
1705b	Other Reference Blocks	181
1709	Sample Ultrasonic Inspection Report	187
1711	Transducer Positions	190
1714	Scanning Patterns.....	192
B 1	Sample Repair Drawing.....	B1
E 1	Weld in Butt Joint	E7
E 3	Weld in Tee Joint	E8
E 4	Weld in Lap Joint.....	E9
E 5	Single Pass Fillet Weld in a Tee Joint	E10
E 6	Single Vee Groove Weld in Butt Joint	E11
F-1	Routing Transmittal	F1
F-2	Request for Information.....	F2
F-3	Progress Report.....	F3
F-4	Material Certifications Summary Form	F4
F-5	Rolled Beam Stringer Heat Number Record	F5
F-6	Girder Heat Number Record.....	F6
F-7	Stringer Status Record	F7
F-8	Girder Status Record.....	F8
F-9	Camber Report	F9
F-10	Sweep Report	F10
F-11	NDT Inspection Record	F11
F-12	Quality Control Repair Summary	F12
F-13	Sign Structure and Pole Status Record	F13
F-14	Secondary and Miscellaneous Status Record	F14
F-15	Expansion Joint Status Record.....	F15

SECTION 1 INTRODUCTION

The **New York State Steel Construction Manual (SCM)** is a part of the Contract Documents for Department of Transportation projects. The SCM supplements the *Structural Steel Section, the Castings, Forgings and Metals Section*, and other provisions of the *NYS DOT Standard Specification, Construction and Materials* as provided therein. The SCM prescribes the minimum requirements for the preparation of fabrication drawings, ordering and receipt of materials, fabrication by welding and bolting, transportation, erection, repair, rehabilitation, and testing and inspection of structural metals. Other project specific contract documents may include additional requirements.

The 3rd Edition of the SCM contains extensive revisions to reflect changes in design and technology since the last publication of this document. Some of the most notable changes are as follows:

- The review and approval process has been streamlined with the DOT preferred use of electronic submissions for shop drawing review.
- Fabricators will have more flexibility when preparing bid documents by providing them with choices of assembly methods that do not require Deputy Chief Engineer Structures [DCES] approval.
- Design of Welded Connections and Stud Welding provisions of the AASHTO/AWS D1.5M/D1.5:2002 *Bridge Welding Code*, hereinafter referred to as the AWS D1.5, have been adopted by the Department, with some modifications.
- The SCM is intended for use with structural steels used in bridge construction that have a specified minimum yield point of 70 ksi [480 MPa] or less.
- Faying surfaces for bolted connections may be primed with Slip B Approved organic zinc rich primers.
- This edition of the SCM also introduces dual units of measurement, with the US Customary Units as the primary unit followed by Metric [SI] Units in brackets to facilitate use with the dual dimensioned AWS D1.5 code.
- The SCM shall also apply to all locally administered Federal Aid projects. For these projects, the terms “State” and “DCES” shall mean “Owner” and “Owner’s Professional Engineer” respectively.

The Contract Documents provide that the Contractor/Fabricator/Erector is responsible for the quality of their own work. When the terms Fabricator and/or Erector are used, contractually, it shall mean the Contractor. Quality Control (QC) during fabrication and erection is the responsibility of the Contractor. Quality Assurance (verification inspection and testing) is the responsibility of the State. QA is provided to help ensure the quality of the material and workmanship and meet the requirements of the Code of Federal Regulations 23 CFR637.

The provisions of this Manual apply to structural steel and other fabricated metal products produced and manufactured in the United States of America. The use of foreign iron and steel products shall meet the requirements of §106-11 *Buy America*, of the Standard Specifications and shall be approved by the FHWA and/or the Deputy Chief Engineer (Construction).

Differences in interpretation of the SCM or other contract documents, including steel repair procedures, between the Contractor and the DOT shall be resolved as determined by the DCES. If any differences exist between specific provisions of the SCM and AWS documents, the provisions of the SCM shall control. The DCES shall be the final authority in the interpretation of the SCM.

Notes:

SECTION 2 DRAWINGS

201. CONTRACT DRAWINGS

201.1 Definition. The drawings which are a part of the Contract Documents, hereinafter designated as the "Contract Drawings," "Contract Plans," or "Plans," are all Contract Drawings under the provisions of the Contract Documents and are not intended to be "Shop Drawings," "Erection Drawings," or other "Working Drawings" required by these specifications. The word Plans will generally be used throughout this manual to describe Contract Drawings.

201.2 Requests for Clarification Any details not sufficiently shown on the Plans will be furnished to the Contractor by the DCES upon request. Any question about notes on the Plans or requests for clarification of specification requirements should be directed to the DCES with informational copies to the Engineer.

201.3 Dimensions. In case of a difference on the Plans between scale dimensions and numbers, the numbers shall be followed.

201.4 Errors. The Contractor shall verify and be responsible for the correctness of all dimensions other than the principal controlling dimensions shown on the Plans, and shall call to the attention of the DCES any errors or discrepancies that may be discovered. The Contractor shall have no claim for damages that may result from following an error except for an error in the principal controlling dimensions and material properties shown on the Plans or listed in the Specifications.

On bridge rehabilitation projects, the Contractor shall be responsible for field verifying all primary controlling dimensions prior to fabrication. Shop drawings of all primary components shall include a note indicating the name of the person who verified the dimension and the date that the dimensions were field verified.

201.5 Principal Controlling Dimensions and Material Properties. The following shall be considered principal controlling dimensions and material properties:

- a) Length of span, i.e., the horizontal distance between bearings, pin centerlines, or other points of support.
- b) Length of member, out-to-out.
- c) Thickness, width and length of plates in primary members.
- d) Dimensions, weight per unit length and length of shapes to be used as primary members.
- e) Diameter, specification and grade of mechanical fasteners, including bolts, nuts, studs, couplers, etc., with type of coatings, if required.
- f) All dimensions of machined pins, hangers and bearing devices.
- g) Camber and horizontal curvature of members.
- h) Elevation of pedestals, bridge seats and other supports for structural steel members.
- i) Specification and grade of metal, including Charpy V-notch toughness requirements where appropriate.
- j) Size of all fillet and partial joint penetration groove welds, and specific weld joint configurations when required.

The Contractor shall be responsible for modifying dimensions of members and pieces to compensate for weld shrinkage, distortion, elastic deformation, camber, sweep, slope, waste for proper machining and oxygen cutting, and other phenomena that may make the initial, in process fabricating dimensions and material ordering dimensions different from the final product design dimensions shown on the Plans.

202. SHOP DRAWINGS

Shop drawings are required for all structural metals except 1) rolled beam bridges not requiring fabrication and 2) miscellaneous metals, unless otherwise waived by the DCES or otherwise specified in the Contract Documents.

202.1 Preparation. When required by the general specifications, the Contractor shall immediately prepare as soon as the contract is signed, complete and accurate shop drawings for all structural metals, machinery and other details, and the connections thereof to the substructure, foundation or other supporting parts.

- a) **Review Sets.** Shop drawings shall be prepared for review as a complete set of drawings hereafter referred to as a review set. The review set includes all layout details, member/component details and subassembly details necessary to completely fabricate each structure, including appropriate note sheets. The drawings shall be arranged systematically within erection divisions or groupings and numbered consecutively in the lower right hand corner, and submitted as a reviewable package. A reviewable package is a review set of shop drawings that is an acceptable submission.
- b) **Review Subsets.** To expedite shop drawing processing for major structures, the Contractor may prepare shop drawings in review subsets when approved by the DCES. Each subset must include all details and notes necessary to fabricate all superstructure components for all stages of work for each erection division, i.e., between expansion joints, hinges, or other system interruptions. The layout drawing for the entire structure must identify each review subset by a unique serialized shop order number.
- c) **Review Schedule.** In order to expedite approval of critical drawings, the Contractor should indicate in the submittal, the order of preference for the review and return of drawings and should submit all drawings in the order of their importance to the construction program.

202.2 Type and Size. Shop drawings shall be neatly and legibly produced and submitted in Adobe pdf file format.

202.3 Project Information Required on Shop Drawings.

- a) **Title Block.** The contract number, project identification number and contract name, together with the County in which the work is to be performed shall be clearly indicated in the title block on each sheet, together with the contractor's name and address, fabricators and sub-fabricator's name and address as appropriate, bridge identification number (BIN), a contract drawing number reference and a unique shop order number or purchase number for the work detailed on the sheet.
- b) **Shop Drawing Numbering System.** The shop drawing numbering system shall follow the guidelines provided in Appendix J.
- c) **Bill of Material.** The shop drawings shall contain a bill of material on the sheet that details the member. The bill of material shall include the pay item number for each shipping unit. If the member has such proportions that more than one sheet is required to fully detail it, the complete bill of material may be placed on the last sheet of the group of sheets detailing the member. The bill of material shall describe in detail all material used in the fabrication of the member, including Charpy V notch toughness requirements. In addition, primary stress carrying pieces

shall be described by their purchase order number and heat number so that direct reference to the certified mill test report describing the steel may be made without difficulty. In lieu of this requirement, the Contractor may submit 1) a Documentation Package as described in Section 306, and 2) after the material has been fabricated the heat numbers log for each fabricated piece that is subject to primary stress. When the structure requires the fabrication of Fracture Critical Members (FCM's), the shop drawings shall accurately identify each fracture critical plate or shape and reference it to the manufacturer's certified mill test report. Reference shall be made by heat number plus plate or shape identification. No FCM will be accepted for use in the structure without compliance with this requirement.

- d) **Component Weights [Masses]** When payment is to be made on a weight [mass] basis, the computed pay weight [mass] of each shipping unit shall be itemized in the bill of material and the total, less deductions as described in Standard Specifications Section 564, *Structural Steel*, clearly marked on the shop drawing on which the unit is detailed. When payment is to be made on a lump sum basis, the shipping weight [mass] of each shipping unit shall be shown on the shop drawing.
- e) **Return Without Examination.** Sets of drawings not meeting the requirements of Section 202.1 – 202.3 may be returned without examination.
- f) **Reference to Contract Sheet Number.** Shop Drawing shall reference the appropriate contract sheet number used in preparation of the details.

202.4 NYSDOT Review of Shop Drawings.

- a) **Process.** The DCES of the Office of Structures, acting through the Metals Engineering Unit (MEU), is the approving authority for shop drawings. The review and approval process shall consist of the following steps:
 - **Initial review:** The MEU reviews the drawings for compliance with requirements and provides review comments if deficiencies are noted. If there are no review comments, the drawings will be electronically stamped “approved”, returned to the fabricator, and the process ends. Fabrication may begin.
 - **Comments and resubmittal – minor revisions needed:** If the deficiencies noted are relatively minor, the drawings will be stamped “approved as noted”, and will be returned with comments. If the fabricator agrees with the comments, fabrication may begin provided that the “approved as noted” drawings are provided to the inspector and that the review comments are incorporated in the work. If the fabricator disagrees with the review comments, the issue must be resolved with the reviewer before fabrication begins.
 - **Comments and resubmittal – major revisions needed:** If the drawings are illegible or have numerous/severe deficiencies, they will be stamped “rejected” and returned to the fabricator. Corrections must be performed and approved by the MEU before fabrication may begin.
- b) **Primary Components.** Shop drawings of primary components of the steel superstructures including layout details, detail drawings and sub-assembly drawings shall be fully reviewed. The review shall include the following:
 1. Principal controlling dimensions, as described in Section 201.5.
 2. Materials specifications, including weld filler metal requirements.
 3. Details of bolted connections and welded joints, including nondestructive testing.
 4. General structural erection framing including the piece shipping weight [mass].
 5. Assembly diagrams, including hole preparation; multiple methods of hole preparation will require a hole legend.
 6. Attachments (not part of the structure) to tension areas of structural members.

7. End cuts of stringers and girders.
 8. Notes pertaining to requirements for workmanship including blast cleaning, thermal cutting, assembly, welding, machining, bolting, painting and NDT requirements.
 9. Railing and bridge joints when details differ from those on the plans.
 10. Bill of materials, including computed weight [mass] when pay measurement unit is by weight [mass].
- c) **Secondary/Ancillary Components.** Certain elements of primary and secondary components of steel superstructures shall be reviewed to a lesser extent than that described above. The following items shall be examined briefly or on a random sample basis:
1. Diaphragms, crossframes, lateral bracing, wind bracing, inspection walks, and other relatively small secondary pieces, crossframe drops.
 2. Girder stiffener spacing shall be reviewed for general but not exact spacing.
 3. Attachments for utilities shall be reviewed for their effect on main structural members.
 4. Dimensions that will not affect structural integrity, or if incorrect, will not cause harmful secondary stress.
- d) **Responsibility for Fit.** In general the Contractor shall be responsible for fit. If errors occur causing difficulty during erection, it shall be the Contractor's responsibility to make the necessary corrections by procedures approved by the DCES.

202.5 Shop Drawing Submittal Procedure. Electronic files of shop drawings may be submitted directly from the fabricator/detailer to the DCES subject to prior approval by the Engineer. The Engineer shall be notified of the submission. When required, other informational copies provided by the fabricator/detailer to the Contractor, other subcontractors, or other interested agencies may be in a format mutually agreeable between all parties. All submissions shall be made using the Routing Transmittal form, Figure 2-1A, Appendix F.

a) **Transmitting Files.**

1. Upon successful uploading of project drawing files, calculations or other files, e-mail must be sent to appropriate parties informing them of the upload. An electronic version of the transmittal letter containing upload information must be attached, and must include a list of files uploaded, including file names and drawing numbers, along with site directory information.
 2. Files will be downloaded and redlined or (pdf/Adobe writer) viewers. Working drawings with many comments may be marked up by using a comment number and separate list of associated comments. The marked up drawing will then be uploaded displaying comment numbers and minor revisions. Alternately, files may be downloaded and printed for traditional review. After manual redlining, drawings will be scanned and reposted to the appropriate site. Upon completion of upload, the DCES will notify all parties involved via email. This procedure will continue until the review process is complete.
 3. A submittal log must be actively maintained by the contractor/fabricator. The log must provide an up-to-date summary of the status of all submittals, and be available on the site to all designated users.
- b) **Site.** The contractor/fabricator has the option of using the Department maintained site or, with DCES approval, establishing and maintaining a separate site for the duration of the project. If the contractor elects to establish a site it may be either a Project Specific Web Site (PSW) or a File Transfer Protocol (FTP) site. The contractor/fabricator site must include the following:

1. A secure, limited access drawing file storage site for all parties, including multiple level security options. Separate accounts with limited access rights must be created for each user.
2. Access 24 hours a day, 7 days a week from any computer with Internet access.
3. Login names and passwords for those authorized by the DCES to access the files.
4. A site directory to provide for management and maintenance of multiple projects.
5. An e-mail account for each approved user.
6. Files of the most current shop drawings for each project.
7. Reports of the current submittal status for each project.
8. Activity updated log of all working drawings submitted for each project
9. A Request For Information (RFI) Repository. Files may be in a *.pdf format, or other format based on approval of the DCES for each project
10. Multi-image, Tagged Image File Format (Tiff File) viewers, if not available online.

202.6 Vacant

202.7 Vacant

202.8 Revisions. Any revision made to shop drawings prior to Signature Approval shall be clearly marked and dated on the drawing as a revision using a letter designation, including revisions resulting from comments marked on the shop drawing by the State during the shop drawing review.

Any revision after Signature Approval shall be clearly marked and dated on the drawing using a numeric designation. For computer generated drawings, the previously approved signature drawing must be submitted with the revised drawing that supersedes it.

202.9 Distribution of Approved Shop Drawings : Immediately upon receiving the final approved shop drawings from the State, the fabricator shall provide electronic copies to the following parties, using the formats in §202.2.

- General Contractor.
- Regional Structures Engineer.
- Engineer-in-charge (EIC).
- Fabricator’s production personnel and NYSDOT’s designated Shop Inspector. Note that any work performed without approved drawings will be rejected.
- Any railroad company or other entity that is directly involved with the project.

202.10 Archiving. After successful erection of the steel component(s), and prior to project completion, the contractor shall transmit an electronic copy of the final Signature Approved Drawings to the DCES. This file will be property of the State. The file format shall be pdf.

See Appendix G for a list of items requiring archiving of Signature Approval drawings.

202.11 Submittal to Railroad Companies and Other Agencies. On Contracts involving one or more railroads or other agencies, the contractor/fabricator shall furnish each railroad company or other agency with duplicate half-size paper reproductions of the shop drawings at the same time shop drawings are submitted to the DCES for review, except that electronic files may be submitted simultaneously, based on prior approval of the receiving agency, in lieu of paper prints. The railroad company or other agency shall forward one copy of the print or electronic file marked with their comments to the DCES, who will incorporate them with other comments and return them to the Contractor/fabricator.

If the railroad company or other agency comments are not received in a timely manner, consistent with the contractual obligations for review of shop drawings as described herein, the DCES will assume that the affected railroad or agency has no comments, and work will progress accordingly. If comments are received by the DCES after the contractual review period (202.13) that cause changes in the approved

shop drawings, those responsible for the late comments will be responsible for all costs incurred as a result of such change.

202.12 Contractor's Responsibility. The Contractor shall carry out the construction in strict accordance with the signature approved shop drawings and shall make no further changes thereon except with the written approval of the DCES. The Quality Assurance (Verification) Inspector shall not approve any steel for shipping from the fabrication shop until the distribution of final approved shop drawings has been made.

Approval by the DCES shall not relieve the contractor from responsibility for errors that may exist in the shop drawings. When the Contractor proposes to use materials or details that are different than those described in the Contract Documents, they shall seek approval of the variance from the DCES before submitting the shop drawings. Any difference between materials and details specified and those shown on the shop drawings shall, unless previously approved, be considered an error on the shop drawings and shall be corrected at the Contractor's expense.

202.13 Detention of Shop Drawings. The DCES shall be allowed two work days for the examination of each drawing in a review set or review subset submittal, or ten work days minimum per set. The DCES will be allowed up to 90 calendar days, maximum, after receipt by the Department to review a set or subset of shop drawings. The review may result in rejection when the drawings do not meet contract requirements or do not contain sufficient detail, in which case, an additional 90 days will be allowed for each subsequent resubmission of a review set or subset. A submittal of shop drawings shall be considered to be all drawings received from a given Contractor for a particular contract in any calendar day, whether they are hard copy or electronic submittals. If the shop drawings are detained for examination for a period longer than stated above, such detention will be taken into account when considering application by the Contractor for an extension of time for the completion of the contract. All shop drawing submittals, whether hard copy or electronic files, are logged in as they are received at the office of the DCES. This log shall be the basis for determining when drawings must be returned without adjustment of the completion date as described herein. For purposes of this section, a work day shall be defined as a *New York State work day*.

202.14 Consultant Engineering Review. If a Consultant is assigned the review of shop drawings, special instructions will be issued by the DCES for submittal, approval distribution, and disposal of the shop drawings.

202.15 Cost of Shop Drawing Prints/ Reproducibles and Microfilm. The cost of all shop drawing prints, reproducibles and microfilm or requirements for electronic file transfer required by the Specifications, shall be included in the price bid for the payment item requiring the drawings. Any prints, reproducibles or files requested beyond the number specified shall be furnished by the Contractor at cost.

203. DETAILING REQUIREMENTS FOR SHOP DRAWINGS

203.1 AASHTO Requirements. All Shop Drawings for bridges carrying highways and miscellaneous metals to be fabricated using the SCM shall be detailed in accordance with the provisions for design and workmanship of the current edition of the *NYSDOT Standard Specifications for Highway Bridges or the NYSDOT LRFD Bridge Design Specifications* as noted on the Contract Documents. Shop drawings shall also be detailed in accordance with modifications specified by the contract documents, including this manual. Whenever the referenced documents do not apply, shop drawings may be prepared in accordance with the current AASHTO/NSBA Steel Bridge Collaboration G3.3, *Shop Detail Drawings Presentation Guidelines*.

203.2 AREMA Requirements. All Shop Drawings for bridges carrying railroad tracks shall be detailed in accordance with the provisions for design and workmanship of the current edition of the American Railway Engineering and Maintenance of Way Association Specifications for *Steel Railway Bridges*, as modified by the Contract Documents that include this Manual.

203.3 Detailing for Welded Fabrication. Full and complete information regarding location, type, size, and extent of all welds shall be clearly shown on the drawings. The drawings shall clearly distinguish between shop and field welds. Those joints or groups of joints in which it is especially important that the welding sequence and technique be carefully controlled to minimize shrinkage stresses and distortion shall be so noted.

Contract design drawings shall specify the minimum size of all fillet welds, and the effective throat for all PJPs. For applications using steel with a yield strength greater than 50 ksi, [345 MPa] the design drawings shall specify the required strength of the weld metal and whether undermatched consumables will be allowed. All fillet welds, all PJPs and all CJPs shall be full length unless otherwise specified in the Contract documents or determined by the DCES.

Shop drawings shall specify the size of all fillet welds and the groove depths of the PJPs applicable for the effective throat required for the welding process and position of welding to be used.

The welding symbol without dimensions designates a complete joint penetration weld, as follows:

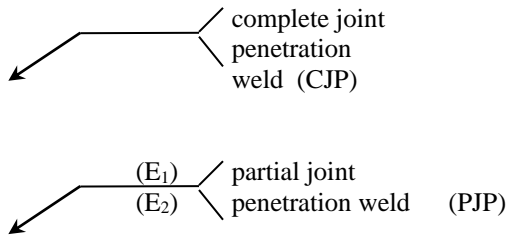

where

E_1 = effective throat, other side

E_2 = effective throat, arrow side

All groove welds shall be complete joint penetration welds unless specifically detailed as partial joint penetration welds on the plans.

Special groove details shall be specified where required.

203.4 Girder Details. The shop drawings for main members shall include a description of the tension areas. This shall be done by dimensioning the limits of tension stress under dead load and live load and showing the dead load point of contraflexure. If the reversal zone is not defined on the Plans, it shall be assumed to extend 10 ft. [3000 mm] each side of the dead load point of contraflexure.

The girder details shall include a camber and horizontal sweep diagram. Offsets from a straight line (end to end of member) shall be given at intervals of 20 ft. [6000 mm] or one tenth of the span length, whichever is less.

Special fabrication or testing procedures shall be directly referenced on the shop drawing for the appropriate fabrication piece.

203.5 Field Splices in Stringers and Girders.

Necessary splice locations are shown on the Plans. If the Contractor desires to move these locations, the Contractor shall have the new splice designed, at no cost to the State, by a licensed professional engineer registered in the State of New York. The design shall be submitted to the designer of record for approval. The decision to allow or disallow the Contractor's request shall be determined by the DCES. Further, the Contractor shall assume responsibility for principal controlling dimensions altered by the approval of a relocated or added splice.

The Contractor shall detail the splices on shop drawings and submit them to the DCES for approval. Shop assembly diagrams shall be submitted for approval, detailing the appropriate assembly procedure described in Section 11, assembly drawing should detail offsets for both the piece and the full end to end segment. The method of hole preparation shall be shown on the assembly drawing and the girder details. The cost of all splices shall be included in the bid price for the steel girder item.

Splices shall meet the following requirements:

- a) Horizontal bolted splices will not be allowed in the webs of members unless detailed on the Plans or approved by the DCES.
- b) When stringers or girders of any cross section are to be spliced by welding in the field, a detailed welding procedure shall be submitted to the DCES for approval. The procedure shall be detailed on shop drawings and submitted for approval prior to the fabrication of structural steel. The request for approval of the detailed field welding procedure, including the method of supporting

members during welding, shall be submitted directly to the DCES. All field welded splices shall be subjected to nondestructive testing in accordance with Section 16, Radiographic Testing or Section 17, Ultrasonic Testing as determined by the DCES. The provisions of Section 1102, Shop Assembly of Field Welded Connections shall apply. FCM's will, in general, not be subjected to any welding in the field. Where field welding is permitted, the DCES will require weld soundness to be verified by both RT and UT

- c) The use of fill plates for primary member splices and connections on new bridges is not permitted unless approval is granted by the DCES. Fill plates may be used on rehabilitation projects where there is no practical alternative. All fill plates shall be the same grade or stronger than the base material. If the base material is galvanized or metalized, the fill plates shall receive the same coating in their entirety.
- d) Web and flange shop butt welds may be moved to extend the thicker plate so that bolted connections are made in materials of the same thickness. The location of bolted splices and extension of thicker flanges shall be such that the distance from a groove welded splice to the centerline of a field splice shall be 5 ft. [1500 mm] minimum or the distance from a groove welded splice to the nearest bolt hole shall be 1 ft. [300 mm] minimum, whichever is greater. All manufacturing dimensional tolerances shall be controlled so that bolted splices may be properly assembled without distortion.
- e) Butt welded field splices in stringers and girders shall be made by complete penetration groove welds which shall be radiographed as required by the Contract Documents.
- f) Bolted splice designs shall use ASTM A325 high strength bolts and be designed in accordance with the NYSDOT LRFD Bridge Design Specifications or the NYSDOT Standard Specifications for Highway Bridges and the SCM. Bolts must be designed for strength and for slip-critical loading using Class A surface condition unless otherwise approved by the DCES.

203.6 Location of Shop Welded Splices in Fabricated Members. Shop welded splices may be located at points in fabricated members that are consistent with lengths of plate available from the mills. Welded joints should be located at points of reduced tensile stress, if this will not create additional labor or material costs for the Contractor.

When flanges or webs of welded plate girders are detailed on the Contract Drawings as a series of plates of varying thickness joined by butt welds, the Contractor may, for the purpose of eliminating butt welds, extend the length of the thicker plate to the end of the next thinner plate or to the end of the member after notifying the DCES. The extra material required by this procedure must be furnished at no additional cost to the State. The maximum thickness transition at any joint shall not exceed a ratio of 1 to 2. Web thickness ratios may exceed this limit if shown on the Plans. If the Contractor increases the thickness of the bottom flange plate at a bearing location, the original girder elevation must be maintained by making suitable compensating changes in the elevation or dimensions of the supports as approved by the DCES. In lieu of this, the Contractor may remove the increased thickness by machining the bottom flange plate at the bearing to maintain the original girder elevation. The transition between the machined surfaces and the adjacent plate surface shall have a slope not greater than 1 on 2 ½.

203.7 Vacant

203.8 Vacant

203.9 Longitudinal Stiffeners. Longitudinal stiffeners shall be continuous for their full length as shown on the plans unless interrupted by a field splice in the girder. They shall be assembled full length using complete penetration groove welds before attachment to the web with full length continuous fillet welds.

- a) Attachment.
1. Connection plates intersecting longitudinal stiffeners shall be notched and fillet welded or groove welded to the longitudinal stiffener at each intersection.
 2. Longitudinal stiffeners shall be groove welded to end bearing stiffeners and any other stiffener or connection plate where the longitudinal stiffener is terminated.
 3. If a longitudinal stiffener is interrupted by a field splice, it shall be terminated on each side of the splice with a minimum of 8 inches [200 mm] of groove weld to the web and a 12 inch [300 mm] radius transition to the web surface (see Figure 203.9A). The transition may be of any shape that will provide, after welding, cutting and finish grinding, a smooth transition from the web surface at a minimum radius of one foot. Special care shall be taken to avoid notches and weld defects at the point where the stiffener is finished tangent with the web.
 4. The detail shown in Figure 203.9A shall also be used to terminate longitudinal stiffeners where there are no intermediate stiffeners or connection plates.

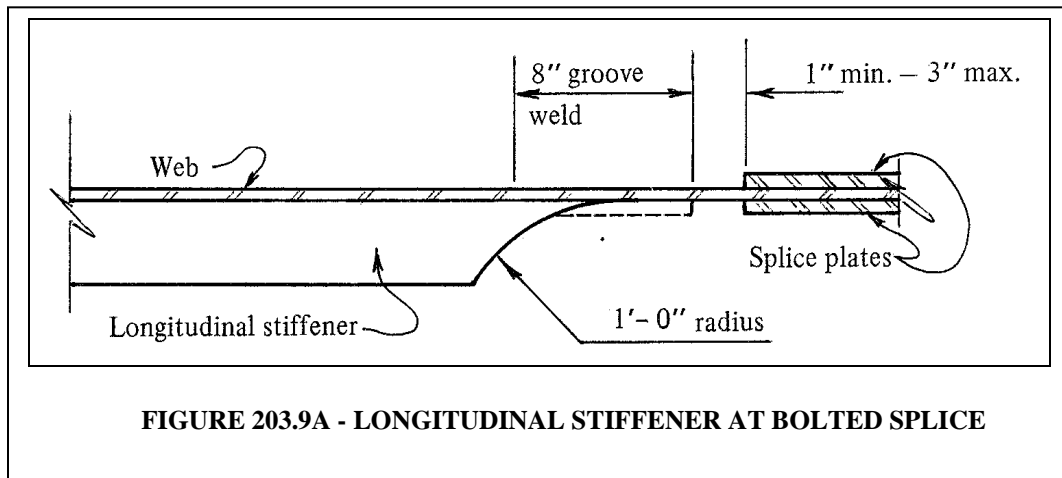

203.10 Lateral Bracing and Diaphragm Connections. In general lateral bracing and diaphragms shall be bolted to the girder as shown on the Plans. Oversize holes will not be allowed for curved girder diaphragms, but may be allowed in diaphragms on straight or skewed bridges provided:

- a) They occur in only one component of the bolted connection.
- b) The holes in the girder flange or stiffener/connection plate are made standard size.
- c) The locations of the oversize holes are indicated on the Shop Drawings.
- d) The exposed oversize holes are covered with a hardened washer.
- e) There is no field reaming of oversize holes without the approval of the DCES.
- f) Bolt holes in the flange of a girder shall be a minimum of 6 inches [150 mm] and, preferably 12 inches [300 mm], from a groove welded flange splice.

203.11 Bearing Sole Plates. When the steel is to be erected to a grade of one percent or less, or the change in height over the length of the sole plate is less than 1/8 inch [3 mm] it will not be necessary to machine the top of the sole plate to a compensating bevel unless otherwise noted on the Plans. No machining of the top of the sole plate will be required if the surface is plane and true as described in Section 612, Machining of Contact Surfaces.

203.12 Curved Girders. When the Contract plans specify welded plate girders with horizontal curvature, the girders shall be fabricated using heat-curving procedures in accordance with Section 15 or by thermal cutting the flanges to the required radius prior to assembly to the web. The camber data for welded plate girders shall be provided by the DCES.

The horizontal curvature and camber, if specified, for rolled beams, shall be fabricated using only heat-curving procedures in accordance with Section 15.

Diaphragms on curved girder bridges shall be treated as primary members.

203.13 Bolt Spacing and Edge Distance. The minimum distance between centers of fasteners shall not be less than the following:

- For 1 1/4 in [30 mm] fasteners:5 in. [125 mm]
- For 1 1/8 in. [27 mm] fasteners:4 in. [100 mm]
- For 1 in. [24 mm] fasteners:.....3 1/2 in. [89 mm]
- For 7/8 in. [22 mm] fasteners:.....3 in. [75 mm]
- For 3/4 in. [20 mm] fasteners:.....2 1/2 in. [64 mm]
- For 5/8 in. [16 mm] fasteners:.....2 1/4 in. [57 mm]

The minimum distance from the center of any fastener to the edge of a plate shall be:

For 1 3/8 in. [36 mm] fasteners:2 3/8 in. [64 mm]
For 1 1/4 in. [30 mm] fasteners:2 1/4 in. [52 mm]
For 1 1/8 in. [27 mm] fasteners:.....2 in. [48 mm]
For 1 in. [24 mm] fasteners:.....1 3/4 in. [42 mm]
For 7/8 in. [22 mm] fasteners:.....1 1/2 in. [38 mm]
For 3/4 in. [20 mm] fasteners:.....1 1/4 in. [34 mm]
For 5/8 in. [16 mm] fasteners:.....1 1/8 in. [28 mm]

In the flanges or legs of rolled sections the minimum edge distance shall be:

For 1 3/8 in. [36 mm] fasteners:1 3/4 in. [46 mm]
For 1 1/4 in. [30 mm] fasteners:1 5/8 in. [38 mm]
For 1 1/8 in. [27 mm] fasteners:1 1/2 in. [34 mm]
For 1 in. [24 mm] fasteners:.....1 1/4 in. [30 mm]
For 7/8 in. [22 mm] fasteners:.....1 1/8 in. [28 mm]
For 3/4 in. [20 mm] fasteners:.....1 in. [26 mm]
For 5/8 in. [16 mm] fasteners:.....7/8 in. [22 mm]

203.14 Seal Spacing.

- a) For sealing, the maximum spacing of fasteners along the free edge of a plate shall be 4 inches [100 mm] plus four times the thickness of the thinner plate, but not more than 7 inches [175 mm].
- b) The maximum distance from any edge shall be eight times the thickness of the thinnest outside plate, or section but shall not exceed 5 inches [125 mm].

203.15 Shop Drawing Requirements for Multi-Dimensional Framing with Numerically Controlled Drilling. Shop drawings shall include a key plan which shows the complete assembly and identifies the selected connections to be check fit. Additionally, the key plan should be consistent with the erection framing and assembly drawings.

- a) Shop drawings shall include a global coordinate reference system that includes (x, y, z) coordinates for the selected connections to be check fit. As a minimum, these points shall include:
 - 1. One global reference point per structure.
 - 2. One transfer point per assembly unit.
 - 3. One control point per plane for each piece/member.
- b) Shop drawings shall indicate connection types as follows:
 - 1. Type 1: Simple shear framed beam connections
 - 2. Type 2: Moment connections with framing in two directions
 - 3. Type 3: Moment connections with framing in three directions
- c) The Contractor shall provide the State with (x,y,z) coordinate data for all holes in a downloadable format.
- d) The QC inspector shall confirm coordinates during shop assembly.

204. ERECTION DRAWINGS

204.1 General. The Contractor shall submit a detailed structural steel erection procedure to the DCES and to the Regional Director for each structure in the Contract. These procedures shall meet all the drawing

requirements of Section 202, Shop Drawings and shall include the required information in Sections 204.2 [drawings] and 204.3 [calculations]. Copies of the drawings shall also be sent for comments to any railroad company or public agency affected by the proposed erection procedure. These drawings must be received at least 30 days prior to the proposed beginning of erection. The Regional Director's office will review any portion of the erection procedure that affects the maintenance of traffic, modifies the existing pavement, or the flow of water and shall verify actual site conditions with what is shown on the erection plans. All comments or revisions required by DCES, Regional office, railroad company, or public agency shall be incorporated in the final submission, which shall then be reviewed by the DCES.

Distribution of copies of the reviewed erection procedure drawings shall be made as described in Section 202.9, except distribution to the Shop Inspection Agency is not required.

204.2 Required Information [Drawings]. Erection drawings shall be signed and stamped by a Professional Engineer registered to practice in New York State. The following minimum information shall be placed on the erection drawings for each individual structure. Erection procedures for similar structures or twin bridges may be shown on the same sheet.

- a) All information required for a Type A lift plan as outlined in §107-05(P) of the latest edition of the NYSDOT Standard Specifications.
- b) Delivery location of each girder.
- c) Pick point locations on each member.
- d) Erection sequence for main members and secondary members (crossframes, diaphragms, lateral bracing, portals, etc.), noting use of holding cranes or temporary supports, falsework, and bents. The erection sequence shall describe the procedure required to stabilize each member during the pick and upon release of the crane.
- e) The method and location of temporary support for field spliced or curved girders, including shoring, falsework, holding cranes, stiffening trusses, guys, etc. Shoring and falsework details to include section sizes, column spacing, etc. The State will examine, but not approve details of temporary supports. The design, erection, and stability of these supports shall be the sole responsibility of the Contractor.
- f) Bolting requirements, including the minimum number of bolts and erection pins required to stabilize members during the erection sequence.
- g) Blocking details needed to prevent movement of components prior to final assembly. Blocking is required in the transverse direction for all bearings that do not limit movement in the transverse direction. Blocking is required in the longitudinal direction for all expansion bearings on a gradient of more than 6%.
- h) Offsets necessary to adjust expansion bearings during erection to provide for temperature variance and dead load rotation when appropriate.

204.3 Required Information [Calculations]. The following calculations shall be prepared by a New York State Registered Professional Engineer and provided for each structure submitted. Calculations shall be checked prior to submittal to the DCES.

- a) Girders:
Calculations verifying the structural integrity and stability of the girders during erection until buckling analysis of all unsupported compression flanges.

b) Temporary Supports & Falsework:

Calculations indicating the load capacity and stability of temporary supports for the structure and the crane. This shall include (but not limited to) column design, and lateral torsion buckling analyses of the falsework carrier beam. For prefabricated towers, manufacturers capacity data can be provided in lieu of computations.

Calculations verifying cribbing and temporary tower elevations.

c) Rigging:

Calculations indicating the capacity of Contractor's/Erector's fabricated rigging. This shall include (but not limited to): lift beams, spreader beams and beam clamps.

d) Foundation Bearing Capacity and Surcharge Loading Effects:

Calculations verifying the foundation bearing capacity of temporary supports, and crane mats.

Calculations verifying surcharge load effects: An analysis of the substructure shall be included when crane footprint causes a surcharge loading on bridge substructures, underground utilities, or other buried structures. A crane shall be defined as having a surcharge load effect on a substructure, when a line on a 1 on 1 slope, measured from the edge of the crane mat, intersects above the bottom of the footing. These calculations shall also include, (but not limited to) outrigger loads on piles, etc. Surcharge loading to underground facilities should be avoided.

[Load Charts and Catalog Cuts]

- a) Crane Load Capacity Charts: Separate Manufacturer's load capacity charts, shall be provided for each crane and boom length used in the work. These charts shall include the percentage of tipping load, and also note conditions such as outriggers, counter weights, and work area.
- b) Catalog cuts for all other pre-engineered devices.
- c) Capacity charts and catalog cuts should clearly mark the components utilized.

205. REPAIR PROCEDURE DRAWINGS

205.1 General. Written repair procedures including details (full or half size drawings when necessary to fully describe the deficiencies) and the proposed repair shall be prepared by the contractor/ fabricator and submitted to the DCES for approval in accordance with Section 202.

205.2 Required Information. When written repair procedures are required for the repair of defects, repair procedure drawings shall be prepared to show the defect in plan view, elevation and section as necessary to adequately locate and describe the defect and the proposed repair. A space shall be provided on the sheet for the inspector's signature to indicate that the defect was inspected and that the drawings accurately describe the defect as it appears prior to repair. The proposed repair procedure shall be described in detail including at least the following information, listed in a proposed sequence of operation:

- a) The area of the steel adjacent to the defect shall be cleaned by grinding to expose the surface boundaries of the defect.
- b) Plan views and sections of the excavations of defects shall be shown. All air carbon arc gouging shall be followed by grinding to remove carbon pick-up and to remove surface irregularities.
- c) Magnetic particle testing shall be performed in accordance with Section 18 to insure that the limits of the defects have been completely removed prior to welding the excavation.
- d) All preheat and interpass temperatures shall be shown. When required, peening, post heat, and stress relief heat treatment procedures shall also be described.
- e) Run-off tabs and back-up bars shall be shown in detail. They shall be removed after welding and all surfaces shall be finished flush by machining or grinding.
- f) The welding procedure specification shall be shown.
- g) Nondestructive testing procedures shall be performed at the completion of the repair. The methods and procedures shall be described on the repair drawing.
- h) A space shall be provided for the Inspector's signature indicating the work has been acceptably completed in accordance with the approved repair procedure.
- i) Sample Repair Drawing. An example of a repair drawing prepared to show a typical repair of a base metal crack is included in Appendix B.

206. TRANSPORTATION CONFIGURATION AND DRAWINGS

206.1 General. All members, both straight and curved, shall be shipped and stored with their webs vertical unless otherwise approved by the DCES. Transportation drawings must be prepared by the contractor/fabricator and submitted to the DCES for approval whenever members must be shipped on their sides. These drawings shall meet all the requirements of Section 202, Shop Drawings, and shall be signed by a NYS licensed professional engineer. Transportation drawings may also be required for members shipped with their webs vertical when there is doubt about the intensity of stress induced by the procedures used to handle, transport or store the members, as determined by the DCES. Any curved member shipped with a cantilever overhang of more than 25 ft. [7.5 m] shall require transportation drawings.

206.2 Required Information. Transportation drawings shall include at least the following information:

- a) The drawings shall be prepared as described in Section 202, Shop Drawings, and as necessary to fully describe the procedures.
- b) Calculation sheets signed by a NYS licensed professional engineer shall be included to show the dead load plus impact stresses induced by the loading and transportation procedure. Impact stresses shall be at least 200% of the dead load stress. The total load including impact shall be not less than 300% of the dead load.
- c) The location of all support points shall be shown. Supports shall be detailed to be under the flanges regardless of the member's orientation.
- d) Tie-downs (types and locations) shall be shown. A sufficient number shall be used to provide redundancy so that if any one tie-down fails, the member will remain stable.
- e) Temporary stiffening trusses or beams shall be shown if they are necessary to provide temporary support (stiffness) to the member during shipping.
- f) Details of a four-way articulating bolster are to be furnished for each truck transporter to insure that truck movements will not produce unnecessary stress in the attached structural steel

207. HEAT CURVING DRAWINGS

207.1 General. Drawings shall be prepared by the contractor/fabricator and submitted to the DCES for approval whenever beams or girders are to be heat curved with the web in the horizontal position or when external preloads are to be applied. The drawings shall be prepared as described in Section 202, Shop Drawings, and shall show the location of all supports, amount and location of external loads (if used), typical heat patterns and other information to describe the work. Calculation sheets shall be included to show the stresses induced in the member by the loading method.

SECTION 3 INSPECTION

301. GENERAL

Quality Control Fabrication inspection and testing and Quality Assurance Verification inspection and testing are separate functions. For the purpose of this manual, the terms Quality Control (QC) and Quality Assurance (QA) shall be used.

Quality Control shall be performed by the fabricator, as necessary. QC shall be performed during all phases of fabrication including prior to assembly, during assembly and during and after welding to insure that materials and workmanship meet the requirements of the Contract Documents. The Quality Control Inspector is the designated person who acts on behalf of the Contractor on all inspection and quality matters within the scope of the Contract Documents. QC is the responsibility of the Contractor.

Quality Assurance is performed by the State to verify the Fabricator's performance in fabricating a quality product according to the Contract Documents. The Quality Assurance Inspector is the State representative responsible for shop verification inspection and testing. The QA Inspector works closely with the Office of Structures' Metals Engineering Unit to insure that fabrication is performed in accordance with the Contract Documents. QA inspection responsibilities are contained in Appendix C of this manual. The State may elect to waive shop QA for noncritical steel components and base acceptance on verification inspections performed at the project site prior to incorporation into the structure.

302. QUALIFICATION OF INSPECTORS

Inspectors shall be qualified and certified by one of the following procedures:

- a) The Inspector(s) shall be an AWS Certified Welding Inspector (CWI) qualified and certified in accordance with the provisions of AWS QCI, Standard for Qualification and Certification of Welding Inspectors,

or,
- b) The Inspector(s) shall be qualified by the Canadian Welding Bureau (CWB) to the requirements of Canadian Standard Association (CSA) Standard WI78.2, Certification of Welding Inspectors,

or,
- c) An Engineer or Technician trained by the Metals Engineering Unit of the Office of Structures, New York State Department of Transportation and approved by the Deputy Chief Engineer, Structures.

Except as provided below, only individuals so qualified shall be authorized to perform Quality Control or Quality Assurance Inspection and tests under the provisions of the Contract Documents.

The Inspector may be supported by Assistant Inspectors who may perform specific inspection functions, with the exception of weld inspection, under the supervision of the Inspector. Assistant Inspectors shall be qualified by training and experience to perform the specific functions to which they are assigned. The work of Assistant Inspectors shall be regularly monitored by the Inspector.

Documented training in materials preparation, coatings application, and inspection is required for the QC and QA coatings inspectors. Acceptable training includes one or more of the following:

- a) American Institute of Steel Construction (AISC) – Application and Inspection of Sophisticated Coatings
- b) National Association of Corrosion Engineers (NACE) – International Coating Inspector training and Certification Program Session I: Coating Inspection Training.
- c) Society for Protective Coatings (SSPC) – Fundamentals of Protective Coatings for Industrial Structures (C-1) or Bridge Coating Inspector Program (BC1).
- d) Other training acceptable to the DCES.

The QA and QC coatings inspectors should each have at least one year of experience in surface preparation and painting inspection. Inspectors who have less experience should work under the guidance of an inspector having those qualifications.

Personnel performing nondestructive tests under the provisions of Sections 16 through 19 need not be qualified and certified under the above provisions.

303. RESPONSIBILITIES OF INSPECTORS

303.1 General. The Inspector shall ascertain that all fabrication, handling, transportation, and erection is performed in accordance with the provisions of the Contract Documents.

The inspector shall be notified in advance of the start of operations that are subject to QC and QA Inspection and Tests.

The Contractor shall furnish the Inspector two copies of the mill order and shall give ample notice to the Inspector prior to beginning the work at the mill and shop, so that Quality Assurance Inspection may be performed by the State. No materials shall be cast, rolled, forged or fabricated before the Inspector has been notified where the orders have been placed.

303.2 Inspection of Materials. The Inspector shall make certain that only materials conforming to the requirements of the Contract Documents are used.

All structural metal shall be furnished to the requirements of the ASTM Designation shown on the plans or listed elsewhere in the Contract Documents. All structural steel shapes and plates used in areas subject to tensile stress as designated on the plans or specified in Section 715 of the Standard Specifications shall be furnished to minimum Charpy V -notch toughness requirements as described in Section 715.

Two unpriced copies of all Purchase Orders (PO's) with all applicable copies of the results of chemical analysis and mechanical tests required by the specifications shall be furnished for all structural metals. These test data shall be given to the Shop Inspector as soon as possible after receipt of the material for submittal to the DCES. When structural metals are furnished under items which do not require Shop Inspection, these data shall be submitted to the Engineer-in-Charge, who will perform visual inspection and examine certified test reports to determine if the materials furnished conform to the requirements of the Contract Documents.

303.3 Inspection of Welding Procedure, Qualification and Equipment. The Inspector shall make certain that all welding procedures are qualified and covered by an approved Welding Procedure Specification or are qualified by tests in accordance with Section 8A, Welding Procedure Qualification. Welding Procedure Specifications and Welding Procedure Qualification Tests shall be subject to the

approval of the DCES prior to beginning the work. The Inspector shall inspect the welding equipment to be used in the work to make certain that it conforms to the requirements of this Manual.

303.4 Inspection of Welder, Welding Operator and Tacker Qualifications. The Inspector shall only permit welding to be performed by welders, welding operators, and tackers who are qualified in accordance with the provisions of Section 8B, Welder, Welding Operator, and Tacker Qualification. When the quality of a welder's, welding operator's, or tacker's work appears to be below requirements of this Manual, the Inspector shall require that the welder, welding operator or tacker demonstrate their ability to produce sound welds by means of a simple test such as the fillet weld break test described in Section 8B or shall require complete requalification in accordance with Section 8B. The Inspector shall require requalification of any welder, welding operator, or tacker who cannot demonstrate to the satisfaction of the DCES, that the welder has used the process for which the welder has been qualified without a break in work experience greater than six months since last qualified as required by Section 8B.

303.5 Inspection of Work and Records. The Inspector shall make certain that the size, length, location and quality of all welds conform to the requirements of this Manual and the approved Shop Drawings and that no unspecified welds have been added without approval of the DCES. The Inspector shall make certain that only welding procedures which meet the provisions of Section 8A, Welding Procedure Qualification, are employed.

The Inspector shall make certain that electrodes for the SMAW and FCAW processes are used only in the positions and with the type of welding current and polarity for which they are qualified. The Inspector shall, at suitable intervals, observe the technique and performance of each welder, welding operator, and tacker to make certain that the requirements of Section 7B, Workmanship and Technique are met.

The Inspector shall examine the work to make certain that it meets the requirements of this Manual as applicable. Size and contour of welds shall be measured with suitable gauges. Visual inspection for cracks in welds and base metal and other defects and/or discontinuities shall be aided by strong light, magnifiers and other devices that may be found helpful. The Inspector shall identify with a distinguishing mark all parts or joints that have been inspected and accepted or rejected.

The Inspector shall keep a record of qualification for welders, welding operators, and tackers, all procedure specifications, procedure qualification test results, material certifications, heat-shrink procedures, approved repair procedures and all other reports of visual inspection and nondestructive tests required by the Contract Documents.

303.6 Photographs and Drawings. When defects are discovered and material is rejected, the DCES may require photographs and dimensioned drawings to accompany the repair procedure submitted by the Contractor to aid in the evaluation of the repair procedure. The same provision shall apply to any structural steel rejected for workmanship deficiencies, failure to meet dimensional tolerances, or damage due to rough handling or accident. In addition, the State may require photographs of specific work or assembly conditions during shop fabrication that are a proper part of the permanent job record. When the DCES requests photographs of any portion of the shop fabrication, the Contractor may furnish the photographs at no additional cost to the State or allow the State to take the photographs. The Contractor shall have the right to direct the taking of photographs so that only the work is recorded and so that no procedure or equipment that is the private development (industrial secret) of the fabricator is revealed.

303.7 QA Inspector's Mark of Acceptance for Shipment. When the structural steel is ready for shipment from the shop and is properly loaded on the rail cars, trucks, or barges, the QA Inspector representing the State shall affix the acceptance stamp of the QA Inspector's company. This acceptance mark shall be made by paint or ink stamp placed near the erection mark on the piece. Each shipping piece, bundle, keg, box or bound pallet shall be acceptance marked by the QA Inspector by direct marking on the piece as described above or by acceptance marking on durable tags when the material is boxed or bundled.

Application of the QA Inspector's acceptance stamp implies that at the time of shipment from the shop, it was the judgment of the Inspector that the structural steel was fabricated from accepted materials by approved processes, painted and loaded for shipment in accordance with the requirements of the Contract Documents. Application of the QA Inspector's stamp of approval for shipment does not imply that the structural material will not be rejected by the State if subsequently found to be defective.

303.8 Report of Shipment of Structural Material (Form B and GC 4b). The acceptance document for all material subject to shop inspection is the Report of Shipment of Structural Material (Form B and GC 4b). When the material is shipped from the shop to the project or to non-shop storage, the QA Inspector shall complete and sign Form B and GC 4b to cover all materials subject to inspection. This document shall indicate to the Engineer that the structural material, if not damaged by shipment, storage, erection, or subsequently found to be defective in workmanship or materials, may be paid for under Progress Payments in accordance with the appropriate Standard Specifications Section.

The Form B and GC 4b shall be forwarded to the applicable Regional Construction Engineer. A copy of the Form should accompany the shipment.

303.9 Shipment of Rejected Material or Material Not Offered for Shop Inspection. When the Contract Documents indicate that materials and fabrication will be subject to shop inspection, no materials will be accepted at the project that do not bear the QA Inspector's mark of acceptance. If it is determined that materials are not acceptance marked because they were not offered for shop and/or final shop inspection, or shipped after rejection at the shop, the materials shall be returned to the shop for inspection and correction as necessary. In lieu of this requirement, the State may, at its discretion, allow inspection to be performed at the project site. This work will be performed by the QA Inspector or other representatives of the QA Inspector's company and all costs for this inspection in the field shall be borne by the Contractor as a condition of the State's approval of inspection of rejected material in the field.

304. FACILITIES FOR INSPECTION

The Contractor shall provide all facilities for inspection of material and workmanship both at the producing mill and the fabricating shop. The Contractor/Fabricator shall provide the QA Inspector(s) with a locking office, desk, chair, locking file cabinet, hanging racks for full size drawings, a telephone for work related calls, access to a facsimile machine and a computer with high speed internet service. The QA Inspector shall be allowed free access to all parts of the premises that are used in the work. Work done while the Inspector has been refused access shall be automatically rejected.

305. INSPECTOR'S AUTHORITY

The State QA Inspector shall have the authority to reject materials and workmanship which do not conform to the requirements of the Contract Documents. State (QA) inspection of materials and workmanship when assigned by the DCES may be conducted before, during and after fabrication. Materials and workmanship which are inspected "in process" (while being fabricated) and which are found to contain defects or to have been subjected to damaging fabrication procedures shall be rejected while still in process. See Section 306, Obligations of the Contractor. The QA Inspector shall have the right to perform, at the expense of the State, nondestructive tests of materials and workmanship. State inspection at the mill and shop is a quality assurance function that may be exercised at the option of the DCES. It is intended as a means of facilitating the work and avoiding errors. It shall be expressly understood that it will not relieve the Contractor of its responsibility to perform Quality Control inspection and tests to insure that its products meet the requirements of the Contract Documents and shall not relieve the Contractor of its responsibility concerning unacceptable materials and workmanship and the responsibility to acceptably repair or replace the same as described in Section 306.

Inspection by State representatives is not a substitute for Quality Control by the Contractor.

306. OBLIGATIONS OF THE CONTRACTOR

The Contractor shall provide a written Source of Supply letter for all steel items. The QA Inspector shall be notified a minimum of 72 hours in advance of the start of fabrication and/or erection operations that are subject to inspection verification. In addition, a written schedule of work, including weekend and overtime shifts, shall be provided to the inspector a minimum of 48 hours prior to the day of the work.

The Contractor shall be responsible for the acceptability of its products. The Contractor's QC Inspectors shall make all necessary visual inspections prior to assembly, during assembly, during welding and after welding to insure that materials and workmanship meet the requirements of the Contract Documents. The Contractor shall comply with all requests of the QA Inspector to correct deficiencies in materials and workmanship as provided in the Contract Documents.

In the event that faulty welding, or its removal for rewelding, damages the base metal so that, in the judgment of the State, its retention is not in accordance with the intent of the Contract Documents, the Contractor shall remove and replace the damaged base metal or shall compensate for the deficiency in a manner approved by the DCES.

The final documentation package shall be given to the QA Inspector for review, acceptance and forwarding to the State a minimum of two weeks prior to shipment. Failure to adhere to this provision may be cause for delay of release by the QA Inspector.

When nondestructive testing other than visual inspection is specified in the Contract Documents, it shall be the Contractor's responsibility to insure that all welds meet the quality requirements for the specified nondestructive test.

If nondestructive testing other than visual inspection is not specified in the original Contract Document but is subsequently requested by the State, the Contractor shall perform any required testing or shall permit testing to be performed by the State. Nondestructive tests shall conform to the requirements of Sections 16, 17, 18 or 19 as ordered by the DCES. The State will be responsible for all associated costs including handling, surface preparation, nondestructive testing and the repair of discontinuities other than those that would be expected to be discovered by visual inspection or discovered by testing specified in the Contract Documents. The rates for work associated with nondestructive testing ordered after execution of the Contract Document shall be agreed upon between the State and the Contractor. However, if such testing should disclose an attempt to defraud or nonconformance to requirements of this Manual, repair-work and/or replacement shall be done at the Contractor's expense.

307. NONDESTRUCTIVE TESTING

307.1 General. When nondestructive testing other than visual inspection is required, it shall be described in the Contract Documents. This information shall designate the categories of welds to be examined, the extent of examination of each category, and the method or methods of testing.

Welds that do not meet the requirements of this Manual shall be repaired by methods described in Section 7B, Workmanship and Technique, or as approved by the DCES. When radiographic testing is used, the procedures and techniques shall be in accordance with the provisions of Section 16 of this Manual. When ultrasonic testing is used, the procedures and techniques shall be in accordance with the provisions of Section 17 of this Manual. When magnetic particle testing is used, the procedures and techniques shall be in accordance with the provisions of Section 18 of this Manual. When dye penetrant testing is used for detecting discontinuities that are open to the surface, dye penetrant testing shall be performed by procedures and techniques that conform to the requirements of Section 19 of this Manual.

307.2 Personnel Qualification. Personnel performing radiographic, magnetic particle and dye penetrant tests shall be qualified in accordance with the current edition of the American Society for Nondestructive Testing, Recommended Practice Number SNT - TC-IA. Only individuals qualified for

NDT Level 1 and working under the supervision of an individual qualified to NDT Level II or individuals qualified for NDT Level II, may perform the above nondestructive tests. The individual's qualifications shall be submitted to the State inspector for review prior to testing. Personnel performing ultrasonic tests shall be qualified by a written examination and performance test administered by the DCES. For more information, see Appendix P, NYSDOT Ultrasonic Testing Technician Program.

308. MILL AND SHOP INSPECTION

All fabricated metal products furnished shall be subject to shop inspection by the State unless otherwise provided in the Contract Documents or waived by the DCES. Steel not permitted to be furnished as stock steel under the conditions set forth herein shall be subject to mill inspection.

Producing mills and/or foundries outside the United States will be subject to inspection and approval by the DCES prior to beginning the work, as required by §106-02 *Quality Requirements* and §106-03 *Plant Inspected Materials* of the Standard Specifications.

All Steel products, including welding rods, shall meet the requirements of Section 106-11 Buy America of the Standard Specifications..

SECTION 4 GENERAL FABRICATION REQUIREMENTS

401. FABRICATOR REQUIREMENTS

401.1 General Requirements. The structural steel fabricator shall have adequate personnel, organization, experience, procedures, knowledge, equipment and plant capable of producing quality workmanship. In addition, prior to fabrication, all steel fabricators must meet one of the following:

- Currently AISC Certified for the appropriate type of work as defined by AISC.
- Performed similar satisfactory work for NYSDOT within the last 5 years.
- Approved by the DCES.

401.2 DCES Approval. The DCES will consider a fabricator's request to provide metals fabrication based on review of the following:

- a) Description of the facility, including the physical plant size, capacity and equipment.
- b) Table of Organization.
- d) Quality Control Manual.
- e) Current welding procedure qualification test records and welding procedure specifications.
- f) Current welder and welder operator qualification test records for the processes to be used in the work.
- f) Resumes of supervisory personnel and other personnel involved in quality assurance, quality control and testing.
- g) After review of the above, the DCES will conduct an inspection of the fabrication shop where the work will be performed. Approval will be based on:
 - 1) Conformance with Article 402, *Minimum Shop Facilities for Fabrication*.
 - 2) Satisfactory performance on previous work, if applicable.
 - 3) Each fabrication plant will be evaluated separately. For purposes of DCES approval, a fabrication plant is defined as a facility or group of facilities owned and operated by the same company, and operated on the same premises, under the same direct supervision and quality control personnel.
 - 4) The shop inspection requirement may be waived at the discretion of the DCES.

402. MINIMUM SHOP FACILITIES FOR FABRICATION

The Contractor (Fabricator) shall provide sufficient lifting capacity, physical plant and equipment for the fabrication and painting of structural steel for the work to be performed. A minimum of two overhead cranes shall be provided. The cranes in each working area shall have a combined rated capacity equal to the lifting weight of the heaviest assembly fabricated for shipment unless alternate lifting and turning facilities are approved by the DCES.

Lifting chains shall be provided with adequate softeners to prevent damage to the corners of material during lifting and turning. If hooks are used for lifting, they shall have sufficient width of jaw and throat to prevent damage to the flanges or to the web-to-flange welds.

Spreader beams, or multiple cranes, shall be provided for lifting plates and long slender members to prevent overstress and distortion from handling.

Shops shall have sufficient enclosed floor spaces to allow all thermal cutting, air carbon arc gouging, assembly, welding and painting to be performed inside, except that shop assembly of field connections for trusses, girders and arches may be performed outside the shop buildings.

The DCES will approve limited fabrication, welding and painting outside the shop, provided the fabricator makes a written request and has made provisions to insure that the quality of work produced outside the shop buildings will not be adversely affected by weather or other conditions.

All cutting, fitting, welding and painting shall be done in areas that are kept dry. Further, areas for all welding shall be kept at a temperature not lower than 40° F for at least one hour before work begins and at all times when work is being performed. In painting areas, the steel shall be at a minimum temperature of 40° F upon application of paint and shall remain at 40° F minimum until the paint is dry, unless higher temperatures are required by the manufacturer's specifications.

Unless modified by other provisions of the Contract Documents, fully automatic SAW welding equipment shall be provided for making all flange-to-web welds, flange and web splices, cover plate to flange, flange to web to welds in box girders, arches, towers and truss web and chord members unless otherwise approved by the DCES.

Semiautomatic (hand-guided) or fully automatic welding SAW, Gas Metal Arc Welding (GMAW) Spray , GMAW Pulse Spray equipment or Flux Core Arc Welding – Gas Shielded (FCAW-G) shall be used for all other principal welds.

The use of the manual Shielded Metal Arc Welding (SMAW) process shall be limited to welding bearing assemblies, minor detail attachments, and other limited welding applications where the use of automatic or semiautomatic welding equipment is impractical because of limited access, or the isolated location and short length of welds involved, unless otherwise approved by the DCES.

All welders using the Flux Cored Arc Welding-Gas Shielded or Manual Shielded Metal Arc Welding processes shall have access to a power chipper or needle descender and to an air carbon arc gouger at all times.

The fabricator must have a quality control department with a CWI on staff, or contracted from an independent inspection agency acceptable to the DCES. The CWI must be present to inspect all materials prior to incorporation in the work, to inspect all fit-up prior to welding, during all multiple pass welding, during assembly, to inspect all preparation for painting, and to perform a final weld inspection after blasting and/or prior to painting.

403. ORDERING OF MATERIALS

The Contractor shall bear all costs for damages which may result from the ordering of materials prior to the approval of the shop drawings, unless the State makes changes in the principal controlling dimensions and material properties, as described in Section 201, after the opening of bids.

All primary member material shall be ordered/purchased directly from the producing mill to the appropriate ASTM designation specified in the Contract documents. Non-primary member material may be ordered/purchased from the producing mill or a warehouse source. If necessary, because of a need to replace defective primary member material, or to order exceptionally small quantities of primary member material, a

fabricator may submit a request in writing to purchase such material from a non-producer warehouse source, provided such material meets all other requirements of the Contract documents and is not to be used in the work until written approval has been granted by the DCES.

404. COMMENCEMENT OF SHOP WORK

No work shall begin until the DCES has approved the fabricator for the work to be done, and has assigned quality assurance inspection, as determined by the DCES.

No shop work shall be started until the shop drawings have been preliminarily approved. Any shop work started prior to the approval of shop drawings shall be done at the Contractor's risk.

405. FABRICATION BY GENERAL CONTRACTORS ON REHABILITATION PROJECTS

In lieu of subcontracting to a fabricator, the General Contractor may request approval to field or shop cut and drill new steel to be installed during general rehabilitation projects using its own resources. The request for approval shall meet the requirements of section 106-01 SOURCES OF SUPPLY, of the Standard Specifications. The State's determination of the request shall be based on the following:

- Past performance on the part of the contractor.
- Adequacy of contractor's equipment.
- Adequacy of contractor's skilled iron workers.

Shop Drawings shall be submitted for all new steel components identified on the contract plans. Some dimensions may be identified as "to be verified in the field" or "use existing holes in steel to remain as a template". Additional required steel components identified during construction, shall be handled as Field Revision Sheets.

The contractor shall submit their proposed method of cutting and/or drilling for approval by the DCES.

All requirements of this manual shall still apply. Work performed without prior DCES approval will be rejected.

Notes:

SECTION 5 BASE METAL

501. GENERAL

This Manual covers structural steels used in bridge and building construction that have a specified minimum yield point of 70 ksi [480 MPa] or less. Grade 100 ksi [690 MPa] steels will not be allowed unless specifically approved by the DCES. All steel shall be furnished in accordance with the provisions of the applicable material specification shown in the Contract Documents or as noted in the material specification entitled "Structural Steel" in the Standard Specifications.

For non-FCM components, stock, or warehouse, material is acceptable if heat traceability and mill test reports for all components to be used are available, and that the material is domestic in origin. Any components which do not have heat stamps with corresponding mill test reports will be rejected. For FCM components, acceptance of stock material is subject to written DCES approval.

502. APPROVED BASE METALS

502.1 Specifications. Steel plates and shapes shall conform to the requirements of the latest edition of AASHTO M270 (ASTM A709) for the grade of steel shown on the Plans or described in the Standard Specifications. All Grade 50 steel that is to be welded shall be Type 1, 2, or 3. Other steel products shall conform to one of the following material specification, as applicable:

- a) Standard Specification for Structural Steel (ASTM A36)
- b) Standard Specification for Cold-Formed Welded and Seamless Carbon Steel Structural Tubing in Rounds and Shapes (ASTM A500 - Grade B)
- c) Standard Specification for Hot-Formed Welded and Seamless Carbon Steel Structural Tubing (ASTM A501)
- d) Standard Specification for High-Strength Low - Alloy Columbium-Vanadium Steels of Structural Quality (ASTM A572-Grade 50)
- e) Standard Specification for High-Strength Low-Alloy Structural Steel with 50,000 psi Minimum Yield Point to 4 inches thick (ASTM A588)
- f) Standard Specification for Pipe, Steel, Black and Hot-Dipped, Zinc-Coated Welded and Seamless (ASTM A53-Grade B)
- g) Standard Specification for Welded and Seamless Steel Pipe Piles (ASTM A252-Grade 2)
Standard Specification for Cold-Formed Welded and Seamless High Strength, Low Alloy Structural Tubing with Improved Atmospheric Corrosion Resistance (ASTMA847)
- h) Stainless Steel Shims, (ASTM A240 Type 304) Specification for Structural Steel Shapes (ASTM A992/A992M)
- i) Standard Specification for Cold-Formed Welded Carbon Steel Hollow Structural Sections (HSS) (ASTM A1085).

502.2 Additional Requirements.

- a) Steel from coils is acceptable for use for girder webs, stiffeners, pipe piles and secondary members provided that the applicable ASTM standards for strength, toughness, and minimum ductility are met. When used for webs, CVN tests shall be required to insure compliance with toughness and ductility requirements. The tests shall be performed after the steel has been straightened and shall be taken from the previously most tightly wound portion of the coil. The tests shall be performed at no additional cost to the State.
- b) Steel conforming to ASTM A500-Grade B shall not be used unless specified in the Contract Documents or approved by the DCES. A500-Grade B steel may not be suitable for dynamically

loaded members in welded structures, where low-temperature notch toughness properties are important.

- c) When a structural steel other than those listed above is approved and such steel is proposed for welded construction, the weldability of the steel and the procedure for welding it shall be established by qualification tests in accordance with the requirements of Section 8, Qualification, as directed by the DCES.
- d) Combinations of any of the steel base metals listed in Section 502.1 may be welded together. In joints involving combinations of base metals, welding preheat shall be in accordance with Table 708 *Minimum Preheat And Interpass Temperature* for the higher strength steel being welded.

503. STEEL FOR PINS, ROLLERS AND EXPANSION ROCKERS

The material furnished for pins and rollers shall conform to the requirements of §715-15 *Pins and Rollers* of the Standard specification as follows, unless otherwise specified in the Contract Documents:

- a) Pins and rollers designed for a minimum of 36 ksi (250 MPa) shall conform to ASTM A668 Class D.
- b) Pins and rollers designed for a minimum of 50 ksi (345 MPa) shall conform to ASTM A668 Class F.
- c) Any pin or roller greater than 12 inches (300 mm) in diameter shall be furnished in accordance with the requirements of ASTM A668 Class G.

504. BACKING, EXTENSION BARS, AND RUN OFF PLATES

504.1 Backing. Backing used for welding steels listed in Section 502.1 may conform to any of the specifications listed in that section, with the following provisos: 1) backing not exceeding $\frac{3}{8}$ inch [9 mm x 38 mm] x 1 $\frac{1}{2}$ inch, furnished as bar stock or cut from plate is exempt from CVN testing, 2) back up bars which are to be left in place on weathering steels shall be of matching chemistry and 3) when approved by the DCES, a ceramic backing may be used in limited applications.

504.2 Extension Bars and Run Off Plates. Extension bars and run-off plates for steels listed in Section 502.1 may conform to any of the specifications listed in that section, or a ceramic material, when approved by the DCES.

505. INTERNAL SOUNDNESS OF PLATES AND SHAPES

505.1 Laminar Defects at Edges and Ends.

- a) Detection of Defects. All plates and shapes shall be subject to a careful visual inspection of edges and ends for the presence of laminar discontinuities and inclusions. The Inspector shall also determine by visual inspection that the steel contains no detrimental discontinuities and that it meets the requirements of ASTM Designation A6 unless otherwise specified.
- b) Repair of Defects. Rejection or repair of laminar discontinuities discovered in the edges of plate up to 4 inches [100 mm] maximum thickness or shapes is described in Table 505, *Visual Inspection and Repair of Edges of Plates and Shapes*. Laminar defects in the edges of shapes discovered by visual examination will be subject to repair or replacement as determined by the DCES. Acceptance, rejection, or repair of steel greater than four inches thick that contains visible discontinuities in edges or ends will be determined under provisions established by the DCES.

505.2 Laminar Defects at Tension Groove Welds

- a) Detection of Defects. The following sequence will be used to determine if rejectable laminar defects are present at the boundary of tension groove welds:

- 1) If during visual inspection, laminar defects are discovered at any location in a plate or shape, the end two feet adjacent to the tension groove weld and the edge to be welded will be subject to magnetic particle inspection.
 - 2) If during the magnetic particle inspection any laminar defects are discovered, ultrasonic testing will be used to search the end 6 inches of the plate or shape adjacent to the tension groove weld.
 - 3) When ultrasonic testing is required, the test procedure described in Section 1708.4 shall be used to determine if the laminar defects are rejectable. This UT inspection shall be performed by the Contractor and witnessed by the Inspector.
 - 4) If the plate is found acceptable by ultrasonic testing, and it is found during magnetic particle inspection that the sum of laminar defect lengths at the boundary of the tension groove weld is less than 15% of the total length of the joint, the steel shall be acceptable for use adjacent to a tension groove weld without repair.
- b) Repair of Defects. When the above inspection procedures reveal rejectable defects at the boundary of a tension groove weld, one of the following methods of repair may be approved in lieu of replacement of the entire plate.
- 1) When the sum of the length of all laminar defects is between 15% and 30% of the length of the joint, and when the end 6 inches [150 mm] of the plate is not rejectable by ultrasonic testing, the defective portion of the end of the plate may be excavated by air carbon arc gouging and the laminated steel replaced by sound weld metal.

The cavity in the edge or end of the plate and any excavation from a plate surface shall have a minimum radius of ¼ inch [6 mm] at the root and the sides shall slope back to provide a minimum angle of 20° at the sides of the excavation and 45° at the ends. An approved welding procedure shall be used to fill the repair excavation and the excess weld metal shall be ground flush. At the completion of welding, the end six inches shall be retested by the ultrasonic test procedure described in this Manual to insure the complete removal of the laminar defects. The area repaired by welding shall also be inspected for weld defects by radiographic inspection.

The repair procedure shall be submitted to the DCES for approval prior to the initiation of repairs.

- 2) When the sum of the length of all laminar defects exceeds 30% of the length of the joint, the end portion of the plate may be removed and replaced to eliminate the defective portion of the plate. The replacement material may be obtained from stock if the heat identity is known and acceptable mill test reports are available. The minimum length of added plate shall be 5 feet [1.5 m] unless otherwise approved by the DCES. A longer plate may be required to insure an area free of laminations at the boundary of the additional tension groove weld. The additional butt weld resulting from the added plate shall be subject to radiographic inspection in addition to the originally detailed weld inspection required by the Specifications. The direction of rolling of the replacement plate shall be parallel to the length of the member. The repair procedure shall be submitted to the DCES for approval and shall be shown as a revision to the approved shop drawings prior to the final acceptance of the repair.

506. STRAIGHTENING MATERIAL PRIOR TO FABRICATION.

All deformed structural material shall be properly straightened prior to being laid out and worked in the shop. Sharp kinks and bends shall only be straightened with the approval of the DCES. Main material i.e.,

components of principal supporting members subject to calculated stress, shall not be bent cold without the approval of the DCES. Heat straightening shall be done in accordance with the provisions of Section 15, Heat Curving, Cambering, and Straightening.

507. DIRECTION OF ROLLING

All primary stress carrying material shall be ordered and prepared so that the direction of rolling is parallel to the direction of the main stress (compression or tension) in the member. This requirement shall apply to the following elements:

- a) Flange and web plates of all fabricated members including: stringers, girders, tub and box girders, towers, columns, arches, bents, rigid frames and truss members.
- b) Splice plates, coverplates, tie plates, truss and arch gusset plates and truss and arch hangers.
- c) Lateral connection plates welded to flanges and webs of stringers, girders or tub and box girders.

508. IDENTIFICATION OF MATERIAL

All primary stress carrying material shall be traceable to its Material Test Report (MTR) by its Heat Number. The Heat Number shall be transferred at the time of thermal cutting to each piece. The heat number shall be applied using low stress steel stamps. The Heat Number Log shall be given to the NYS inspector for review as soon as possible after assembly but prior to painting. Loss of traceability at any point in fabrication shall be cause for rejection.

**TABLE 505 - VISUAL INSPECTION AND REPAIR OF EDGES OF PLATES AND SHAPES
(4 inches AND UNDER IN THICKNESS)**

<i>Description of Discontinuity</i>	<i>Repair Required</i>
Any discontinuity 1 inch in length or less	None - need not be explored
Any discontinuity over 1 inch in length and 1/8 inch maximum depth	None - depth shall be explored by random spot grinding well faired in order not to create notches in the plate edge
Any discontinuity over 1" in length with depth over 1/8 inch but not greater than 1/4 inch	Remove by grinding or air carbon arc gouging followed by grinding. The excavation shall be well faired in order not to create notches in the plate edge If the removal of a discontinuity reduces the net cross section area of the plate by more than 5%, the resultant cavity shall be filled by welding** Aggregate length of welding shall not exceed 20% * of plate edge length being repaired
Any discontinuity over 1" in length with depth over 1/4 inch but not greater than 1 inch	Completely remove and weld. Aggregate length of welding shall not exceed 20%* of plate edge length being repaired **
Any discontinuity over 1 inch in length with depth greater than 1 inch	Subject to approval by the DCES. Gouge out to 1" and block off by welding. Aggregate length of welding shall not exceed 20% * of plate edge length being repaired.**
*Defects exceeding this length require the approval of the DCES before being repaired. **Repair welding of tension members will be subject to radiographic inspection.	

NOTES:

1. This specification applies only to edges which will not be joined by welds subject to calculated stress. This specification does not apply to any plate or shape that is subject to stress across its thickness (i.e., in "Z" direction).
2. Length of a defect is the visible long dimension on an edge. Depth is the distance that the defect extends into the plate or shape from the edge.
3. All manual welding shall be performed by qualified welders using low-hydrogen electrodes. Submerged Arc Welding and Flux Cored Arc Welding with external gas shielding may also be used with approved procedures. Cavities resulting from the removal of discontinuities shall be prepared prior to repair welding with a minimum radius of 1/4 inch and a minimum included angle of 20 degrees. When plate thickness is not sufficient for such preparation, repair welding will not be permitted.

Notes:

SECTION 6 PREPARATION OF BASE METALS

601. CUTTING – GENERAL

Steel and weld metal may be thermally cut provided a smooth and regular surface, free from cracks and notches is obtained. All thermally cut surfaces shall be produced using a mechanically guided torch unless otherwise approved by the DCES. Thermal cut surfaces produced by a manually guided torch, when allowed, shall be smoothed by machining or grinding.

In all thermal cutting, the cutting flame shall be adjusted and manipulated to avoid cutting beyond (inside) the prescribed lines. The roughness of thermal cut surfaces shall not exceed the American National Standards Institute surface roughness value of 1000 microinches for material up to 4 inches thick and 2000 microinches for material 4 inches to 8 inches thick, except, at the dead ends of members where there is no calculated stress, the roughness shall not exceed 2000 microinches. Roughness exceeding these values and occasional notches or gouges no more than ¼ inch deep on otherwise satisfactory surfaces shall be removed by machining or grinding. Cut surfaces and edges shall be free of slag. Correction of discontinuities shall be faired to the oxygen cut surfaces with a slope not exceeding 1 in 10.

Occasional notches or gouges that exceed ¼ inch shall be repaired by welding. The repair of notches or gouges over 7/16 inch deep shall be referred to the DCES prior to repair. Welding repairs shall be made by suitably preparing the discontinuity, welding with an approved process after preheating in accordance with Table 708, *Minimum Preheat And Interpass Temperature* and grinding the completed weld smooth and flush with the adjacent surface to produce a workmanlike finish. All welded repairs to main material subject to tensile stress shall be tested by ultrasonic or radiographic inspection as determined by the DCES.

602. THERMAL CUTTING OF A709 STEELS (50,000 psi minimum yield strength or higher)

The Contractor (Fabricator) shall take steps to insure that the flame cut edges of primary/main material are not hardened by the cutting process. This may be achieved by preheating, post heating or control of the burning (cutting) process. Flame cut edges found to have a Rockwell Hardness Value of C 30 or greater will be considered unacceptable. A portable Rockwell Hardness Tester shall be employed by the Quality Control Inspector to determine conformance with these requirements. Unacceptably hard surfaces shall be removed by grinding, machining, or approved heat treating procedures.

603. SURFACES AND EDGES TO BE WELDED

Surfaces and edges to be welded shall be smooth, uniform, and free from fins, tears, cracks and other discontinuities which would adversely affect the quality or strength of the weld. Surfaces to be welded and surfaces adjacent to a weld shall also be free of loose or thick scale, slag, rust, moisture, grease and other foreign material that will prevent proper welding or produce objectionable fumes. Mill scale that withstands vigorous wire brushing, a thin rust inhibitive coating, or antispatter compound may remain except that all mill scale shall be removed from the surfaces on which flange-to-web welds are to be made by any of the approved welding processes. This provision shall apply to all girders, stringers, beams, bridge columns, bents, towers, rigid frames, arches, truss chords and truss web members. The provision for removal of all mill scale prior to making web-to-flange welds shall not apply to secondary members, building columns or to members subjected to general blast cleaning prior to welding, where essentially all mill scale has been removed and no harmful rusting has occurred subsequent to blast cleaning, as determined by the Inspector.

No mill scale shall be permitted to remain in the boundary of a groove weld subject to tensile stresses resulting from the design loads.

Unless otherwise specified, edges of material thicker than specified in the following list shall be thermal cut to produce a satisfactory welding edge wherever a weld along the edge is to carry calculated stress:

Sheared edges of material thicker than.....	1/2 inch
Rolled edges of plates (other than Universal Mill Plates) thicker than.....	3/8 inch
Toes of angles or rolled shapes (other than Wide flange sections) thicker than.....	5/8 inch
Universal Mill plates or edges of flanges of Wide flange sections thicker than.....	1 inch

The form of edge preparation for butt joints shall conform to the requirements of AWS D1.5 Section 2 except as modified by Section 7A of this manual. Machining, air carbon arc gouging, oxygen cutting, chipping, or grinding may be used for joint preparation, back gouging, or the removal of defective work or material. All air carbon arc gouged surfaces shall be ground after gouging to remove any carbon pick-up.

604. FLANGE PLATES

All flange plates shall be furnished with thermal cut edges which have the corners chamfered at least 1/16 inch by grinding.

605. WEB PLATES

Web plates of built-up beams and girders, box girders and box arches shall be thermal cut to produce the prescribed camber. The fabricator shall cut sufficient extra camber into the webs to provide for all camber losses due to welding, cutting, heat curving, etc.

606. TRUSS MEMBERS

All plates in welded sections of truss web, arch and chord members shall have their longitudinal edges prepared by thermal cutting. Edges of plates not joined by welding shall have their corners chamfered at least 1/16 inch by grinding.

607. STIFFENERS AND CONNECTION PLATES

Stiffeners and connection plates welded transverse to girder webs and flanges may be furnished with sheared edges provided their thickness does not exceed 3/4 inch [19 mm]. Mill edge plate may be used provided its thickness does not exceed 1 inch [25 mm]. All other stiffeners and connection plates shall be furnished with thermal cut edges. All stiffeners and connection plates that are to be painted shall have their unwelded corners chamfered at least 1/16 inch by grinding. Stiffeners and connection plates shall be prepared with clipped corners (snipes) to provide clearance for the web to flange fillet welds. The dimension of the snipe in the vertical direction shall be 5 times the web thickness. In the horizontal direction, the snipe shall generally be 1 1/2 inch [38 mm].

608. LATERAL GUSSET PLATES

Gusset plates and other connections welded parallel to lines of stress in tension members shall have the sides parallel to the lines of stress thermal cut whenever their thickness exceeds 3/8 inch. Bolted lateral gusset plates may be furnished with sheared edges provided the thickness does not exceed 3/4 inch [19 mm]. All gusset plates that are to be painted shall have all of their corners chamfered at least 1/16 inch by grinding.

609. SPLICE PLATES AND GUSSET PLATES

Girder and stringer splice plates and truss gusset plates shall be furnished with thermal cut edges.

610. VACANT

611. BENDING OF STRUCTURAL STEEL PLATES

Unless otherwise approved by the DCES, there shall be no cold or low heat bending of material carrying primary stress. To facilitate bending, the steel shall be heated between 1100° and 1200° F over the entire area and cross section to be bent. Heating methods and equipment shall be as described in Section 15 *Heat Curving, Cambering, and Straightening*.

When flange plates or connection plates carrying primary stress are required to be bent to a radius of 2 feet [600 mm] or less, the area to be bent shall be heated for the full width of the flange and for a length of at least six times the thickness of the flange. No bending force shall be applied until this entire area is heated to a temperature between 1100° and 1200° F. After bending is complete, and the temperature of the plate has cooled to ambient temperature, all surfaces of the heated area shall be magnetic particle inspected in accordance with Section 18, *Magnetic Particle Inspection*.

612. MACHINING OF CONTACT SURFACES

612.1 Bearing Surfaces. The surface finish of bearing and base plates and other bearing surfaces which are to come in contact with each other or with concrete shall meet the American National Standard for Surface Roughness as defined in ANSI B46.1, Surface Roughness, Waviness and Lay, Part I.

Steel slabs or plates in contact with a concrete surface:	ANSI 2000
Heavy plates in contact as part of bearing assemblies which are welded:	ANSI 1000
Ends of compression members, bearing stiffeners and fillers in compression:	ANSI 500
Rollers and rockers:	ANSI 250
Pins, pin holes, rotating portion of top of rockers and rocker sockets in sole plates:	ANSI 125
Sliding bearing – steel to copper alloys or steel to stainless steel:	ANSI 125
Sliding bearing – stainless steel to polytetrafluoroethylene (PTFE):	ANSI 5 (No. 8 bright mirror finish)

Sliding bearings with a surface roughness greater than ANSI 60 shall be machined so that the lay of the cut is parallel to the direction of movement.

Machined surfaces shall be plane and true conforming accurately to the dimensions shown on the plans.

Machined surfaces designed to be flat shall be flat within 0.010 inch [0.25 mm].

Parts in bearing shall have uniform even contact with the adjacent bearing surface when assembled. The maximum gap between bearing surfaces shall be 0.040 inch [1 mm] unless a closer tolerance is specified. Base and sole plates that are plane and true need not be machined when their surface roughness does not exceed the values noted above, except that, sliding surfaces of base plates must be machined.

Surfaces of fabricated members shall not be machined until all fabrication on that particular assembly or subassembly is complete. Metal components that are to be heat treated shall be machined after heat treatment.

612.2 Abutting Joints. Abutting compression members shall be machined as specified above unless the Contract Documents indicate otherwise. Ends of abutting tension members shall be machined or

machine burned to an ANSI surface roughness value not exceeding 1000 microinches to secure close and neat but not contact fitting joints. When the design is based upon transmitting all stress through the fasteners, the Contract Documents may detail all joints open 1/4 inch [6 mm] maximum, in which case ends of members will be treated as abutting tension members regardless of direction of stress.

612.3 End Connection Angles. End connection angles of floor beams and stringers shall be flush with each other and accurately set as to position and length of member. In general, end connection angles shall not be finished unless required by the Contract Documents. However, faulty assembling and connecting may be cause for requiring them to be milled, in which case their thickness shall not be reduced by more than 1/16 inch [2 mm], nor shall their fastener bearing value be reduced below design requirements. End connection angles shall be milled after assembly to floor beams when called for on the Plans.

613. BOLT HOLES IN STEEL MEMBERS

613.1 General. The following methods of hole preparation may be used as indicated in Section 11 and shall be clearly shown on the shop drawings:

DA: Drill in Assembly: Holes marked DA shall be drilled full size from solid at assembly.

DT: Drill To Template in Assembly: Holes marked DT shall be core drilled full size using a steel template with hardened steel bushings. Prior to full size drilling, connecting parts shall be assembled and match marked.

DTU: Drill to Template Unassembled: Holes marked DTU shall be core drilled full size using a steel template with hardened bushings, unassembled.

CNC-MDT: Match Drill Template: Holes marked CNC-MDT shall have one ply drilled full size using CNC, while remaining plies to be core drilled full size from solid using first (full size) ply as a one time template only. Prior to full size drilling, connecting parts shall be assembled and match marked.

RA: Ream in Assembly: Holes marked RA shall be sub-punched or sub-drilled 1/4 inch undersize and reamed to full size with connecting parts assembled and match marked.

RTA: Ream to Template in Assembly: Holes marked RTA, on bridge rehabilitation projects, shall be sub-punched or sub-drilled 1/4 inch undersize, and reamed to full size in the field (using the existing steel component and its associated holes) as a one time template. Prior to reaming, connecting parts shall be assembled.

CNC: Computer Numerical Control Drilling: Holes marked CNC to be drilled full size unassembled by means of numerically controlled equipment.

Drill in Assembly: (DA) Drilled to Template: (DT) and Drilled to Template Unassembled: (DTU)

Holes drilled from the solid shall be 1/16 inch [2 mm] larger than the nominal diameter of the fastener.

Holes shall be accurately placed, perpendicular to the faying surface, cylindrical, and shall show no offset between adjacent plies.

Burrs on the surfaces shall be removed by a method that leaves the hole free of burrs inside and out. The method shall not dish-out (reduce its thickness) the metal in the vicinity of the hole.

Match Drill Template: (CNC-MDT)

Holes match drilled shall be $\frac{1}{16}$ inch [2 mm] larger than the nominal diameter of the fastener.

Holes shall be accurately placed, perpendicular to the faying surface, cylindrical, and shall show no offset between adjacent plies.

Burrs on the surfaces shall be removed by a method that leaves the hole free of burrs inside and out. The method shall not dish-out (reduce its thickness) the metal in the vicinity of the hole.

Twist drills, reamers and hand held drilling equipment will not be allowed for this method.

Ream in Assembly: (RA)

Before Reaming:

Holes which are to be reamed shall be sub punched or sub-drilled.

The size of the sub size holes shall be as follows:

- a) For bolts greater than $\frac{3}{4}$ inch [19 mm] diameter, the sub size hole shall be $\frac{3}{16}$ inch [5 mm] smaller than the nominal diameter of the fastener ($\frac{1}{4}$ inch [6 mm] smaller than the final hole diameter).
- b) For bolts of $\frac{3}{4}$ inch [19 mm] diameter or less, the sub size hole shall be $\frac{1}{16}$ inch [2 mm] less than the nominal diameter of the fastener ($\frac{1}{8}$ inch [3 mm] smaller than the final hole diameter).

For sub-punched holes, the diameter of the die shall not exceed the diameter of the punch by more than $\frac{1}{16}$ inch [2 mm]. The sub punched hole shall be clean cut, without torn or ragged edges.

Subsize holes shall be so accurately done that, after assembling the component parts of a member or an assembly of connecting members and before reaming, a cylindrical pin $\frac{1}{8}$ inch [3 mm] smaller than the nominal diameter of the punched hole may be passed through at least 75% of any group of contiguous holes in the same surface. If this requirement is not fulfilled, the pieces shall be rejected. If any such hole will not pass a pin $\frac{3}{16}$ inch [5 mm] smaller than the nominal diameter of the sub size hole, this shall be cause for rejection. The requirement for the fitting of subsize pins during assembly is to insure that when reaming is performed, all cold worked (punch sheared) material will be removed from surfaces of the hole and to provide the hole quality required by these specifications. For sub-punched holes, the depth of removal shall be $\frac{1}{16}$ inch [2 mm] minimum. If the accuracy of subpunched work will not guarantee this hole quality when reamed, the size of the sub punched hole shall be reduced so that reaming will remove all cold worked material.

During Reaming:

Reaming of fastener holes shall be done with twist drills or with tapered reamers. Reamers preferably shall not be guided by hand. No oil or grease shall be used as a lubricant unless all such material is removed by solvent cleaning before final assembly, painting and shipment. Any drift pinning done during assembly shall be only the minimum necessary to bring the parts into position, and not sufficient to enlarge the holes or distort the metal.

After Reaming:

After reaming is completed, the holes shall be $\frac{1}{16}$ inch [2 mm] larger than the nominal diameter of the fastener. Additionally, holes shall be perpendicular to the faying surface and 75% of any group of contiguous holes in the same surface shall show no elongation of the hole greater than $\frac{1}{32}$ inch [1 mm]. The remainder of the holes shall not be elongated greater than $\frac{1}{16}$ inch [2 mm].

Burrs resulting from reaming shall be removed.

Reamed or drilled parts shall not be interchanged.

Computer Numerical Control Drilling (CNC):

Method shall be reviewed by DCES for all main members. CNC shall follow check-fit assembly requirements and procedures described in Section 11.

Holes match drilled shall be $\frac{1}{16}$ inch [2 mm] larger than the nominal diameter of the fastener.

Holes shall be accurately placed, perpendicular to the faying surface, cylindrical, and shall show no offset between adjacent plies.

Burrs on the surfaces shall be removed by a method that leaves the hole free of burrs inside and out. The method shall not dish-out (reduce its thickness) the metal in the vicinity of the hole.

613.2 Bolt Holes in Primary Members:

Girders, Stringers, Floorbeams, Arches, Towers, Bents, and Rigid Frames

Holes shall be drilled in assembly using either: RA, DA, DT, CNC-MDT, or accomplished by a method such as CNC approved by DCES. This information shall be noted on the shop drawing: assembly drawings and numbered girder drawings. See Section 11 for assembly requirements.

The following ancillary components shall also have their holes made as noted above:

- a) Lateral connection plates that are welded to tension flanges of the members listed above.
- b) Hangers, connection plates, splice plates, tie plates, and gusset plates which support the members listed above.

Reaming or drilling shall be done after mating pieces are assembled to the control lines approved on the Shop Drawings and firmly bolted together. Reamed or drilled parts shall not be interchanged.

613.3 Bolt Holes in Primary Members: Trusses and Lift Bridges

Members include: top chord, bottom chord, verticals, diagonals, floorbeams, and floorbeam connection angles.

Holes shall be drilled in assembly using either: RA, DA, DT, CNC-MDT, or accomplished by a method approved by DCES.

This information shall be noted on the shop assembly drawings. See Section 11 for assembly requirements.

Reaming or drilling shall be done after mating pieces are assembled to the control lines approved on the Shop Drawings and firmly bolted together. Reamed or drilled parts shall not be interchanged.

Gusset plates or other parts attached to top and bottom chords, shall have holes: RA, DA, or drilled by a method approved by the DCES.

614. BOLT HOLES IN SECONDARY MEMBERS AND COMPONENTS

614.1 General. Secondary members and components are those members that are not described as primary stress carrying members in Sections 613.2 and 613.3 and do not support main members. Holes in secondary members may be made by any method described in Section 613.1 or they may be punched full size when the thickness of the steel does not exceed $\frac{3}{4}$ inch [19 mm]. For punched holes, the diameter of the die shall not exceed the diameter of the punch by more than $\frac{1}{16}$ inch [2 mm]. Holes must be clean cut without torn or ragged edges.

614.2 Size of Holes in Secondary Members. Standard size holes may be used in all plies of secondary members. Oversize holes may be used at locations described in Section 203.10. The diameter of oversize holes shall be $\frac{3}{16}$ inch [5 mm] larger than bolts $\frac{7}{8}$ inch [22 mm] and less in diameter, $\frac{1}{4}$ inch [6 mm] larger than bolts 1 inch [25 mm] in diameter, and $\frac{5}{16}$ inch [8 mm] larger than bolts $1\frac{1}{8}$ inch [29 mm] and greater in diameter.

615. PINS AND ROLLERS

615.1 General. The material furnished for pins and rollers shall conform to the requirements of Section 503 unless otherwise specified in the Contract Documents. Pins and rollers shall be accurately manufactured to the dimensions shown on the plans. The surface finish shall be as required by the Specifications. Pins larger than 9 inches [425 mm] in diameter shall have a hole not less than 2 inches [50 mm] in diameter bored longitudinally through their centers. The hole shall be bored before the pin is subjected to heat treatment. Boring shall be conducted in a manner that will prevent damage to the pin. Pins which contain interior defects shall be rejected. The minimum radius on any reentrant cut machined in a pin or roller shall be $\frac{1}{4}$ inch [6 mm].

615.2 Boring Pin Holes. Holes for pins shall be bored true to detail dimensions, smooth and straight, normal to the axis of the member and parallel with any other pin hole in the same member unless otherwise required. A finishing cut shall always be made. The length outside to outside of holes in tension members and inside to inside of holes in compression members shall not vary from detailed dimensions more than $\frac{1}{32}$ inch [1 mm]. Boring of holes in fabricated members shall be done after the riveting, bolting or welding is completed.

615.3 Pin Clearances. The diameter of the pin hole shall not exceed that of the pin by more than 0.020 inch [0.5 mm] for pins 5 inches [125 mm] or less in diameter, or 0.035 inch [0.9 mm] for larger pins.

615.4 Pin Threads. Pin threads shall make close fits in the nuts and shall meet the American National Standards Institute requirements for unified screw threads (ANSI B1.1) except that for diameters greater than 1½ inch [38 mm], pins shall be made with 6 threads per 1 inch [25 mm].

615.5 Pilot and Driving Nuts. Two pilot nuts and two driving nuts shall be furnished for each size of pin, unless otherwise specified.

616. BRONZE SURFACED EXPANSION BEARINGS

Bronze shall conform to ASTM B100, Copper Alloy No. 510 or 511, or ASTM B22, Copper Alloy No. 911 or 913 unless otherwise specified. Attachment shall be by fillet welds or a combination of fillet welds and plug welds or by brazing as approved by the DCES. If the bronze surface is plane and true within 0.010 inch [0.25 mm] after welding, there need be no machining of the bronze surface. Machining shall not reduce the bronze thickness to less than $\frac{3}{32}$ inch [2 mm] at any location.

SECTION 7
WELDING
Part A – Design of Welded Connections

The New York State Steel Construction Manual adopts AASHTO/AWS D1.5: Bridge Welding Code, Section 2, Design of Welded Connections, with the following modifications:

On page 5 of AASHTO/AWS D1.5: 2002 Bridge Welding Code delete Section 2.1.1, 2.1.2 and 2.1.3.

On page 5 of AASHTO/AWS D1.5M/D1.5: 2002, Bridge Welding Code, revise Section 2.1.6 (2) to read as follows:

(2) For all CJP groove welds where the stress in the weld is tension or compression parallel to the weld axis, providing shear on the effective weld area meets AASHTO design requirements as modified by NYSDOT specifications for all applications. The use of undermatched filler metal in CJP welds transverse to the direction of primary stress will not be allowed unless specifically approved by the DCES. When approved, for CJP groove welds in compression, undermatching up to 70 MPa [10 ksi] may be used. Weld sizes shall be based on the strength of filler metal that is required to be used, or the strength of filler metal that may be used. Weld sizes and weld metal strength levels shall be in conformance with AASHTO Design Specifications as modified by NYSDOT specifications. Design drawings shall show the weld size and, where required or allowed, the undermatching filler metal strength classification shall be shown. Shop drawings shall show the weld size and filler metal strength classification when undermatching filler metal is to be used. When no filler metal strength is shown, matching filler metal shall be used.

On page 6 of AASHTO/AWS D1.5M/D1.5: 2002, Bridge Welding Code, revise Section 2.3.2.3 as follows:

2.3.2.3 The minimum effective length of all fillet welds, including intermittent and tack welds, shall be at least four times the nominal size, or 40 mm [1-½ in.] whichever is greater.

On page 6 of AASHTO/AWS D1.5M/D1.5: 2002, Bridge Welding Code, add a NEW Section 2.3.5 as follows:

2.3.5 Seal Welds. Seal welding shall preferably be accomplished by a continuous weld combining the functions of sealing and strength. Seal welds should be detailed as fillet or groove welds on the shop drawings

On page 7 of AASHTO/AWS D1.5M/D1.5: 2002, Bridge Welding Code, add a NEW Section 2.7.2 as follows:

2.7.2 Joints may be designated prequalified when using one of the following processes: manual shielded metal arc (SMAW), submerged arc (SAW), flux cored arc welding (FCAW) with external gas shielding, or gas metal arc welding (GMAW).

On page 10 of AASHTO/AWS D1.5M/D1.5: 2002, Bridge Welding Code, add a NEW Section 2.9.8 as follows:

2.9.8 Plug and slot welds are not permitted in primary or secondary members. Plug and slot welds may be used in ancillary members such as handrail splices when approved by the DCES.

On page 10 of AASHTO/AWS D1.5M/D1.5: 2002, Bridge Welding Code, add NEW Sections 2.12.1.1 through 2.12.1.9 as follows:

2.12.1.1 The *As Detailed Tolerances* for all prequalified joints described in Figures 2.4 and 2.5 will not be allowed.

2.12.1.2 When flux cored arc welding (FCAW) is used with the prequalified joints described in Figures 2.4 and 2.5, external shielding gas must be used unless otherwise approved by the DCES.

2.12.1.3 The “f” dimension shall have the following minimum dimensions for all pre-qualified joints described in Figures 2.4 and 2.5:

Single Preps $f = \frac{1}{3}T$

Double Preps

For SMAW & FCAW $f = \frac{1}{8}$ " and $S1 = \frac{2}{3} (T1 - \frac{1}{8})$

For SAW $f = \frac{1}{4}$ " and $S1 = \frac{2}{3} (T1 - \frac{1}{4})$

2.12.1.4 For Joint Details TC-U4, TC-U5, TC-U8, and TC-U9 delete the joint detail showing prep of T2.

2.12.1.5 For Joint Detail B-U4a-GF delete “ $R = \frac{3}{16}$ and $a = 30$ ”.

2.12.1.6 For all Single U-Groove Joint Details add note 6 for all “C” (corner) joint designations.

2.12.1.7 Delete all Single J-Groove Butt Joints.

2.12.1.8 All joints with an **F** designation under the “Allowed Welding Positions” column shall not be allowed unless approved by the DCES.

2.12.1.9 For all joints in Figures 2.4 and 2.5 add the following note: Any deviation from the details shown shall be subject to approval of the DCES.

On page 44 of AASHTO/AWS D1.5M/D1.5: 2002, Bridge Welding Code, add a NEW Section 2.13.1.2 as follows:

2.13.1.2 Partial joint penetration groove welds made by any weld process in butt, corner and tee joints may not be used unless shown in the Contract documents or specifically approved by the DCES.

On page 44 of AASHTO/AWS D1.5M/D1.5: 2002, Bridge Welding Code, REVISE Section 2.14 (1) to read as follows:

(1) All PJP groove welds in butt joints except those conforming to 2.17.3, including PJP groove welds where the applied tensile stress is normal to the effective throat of the weld. NOTE: This does not prohibit the use of PJP tee and corner joints when detailed on the Plans.

On page 44 of AASHTO/AWS D1.5M/D1.5: 2002, Bridge Welding Code, REVISE Section 2.14 (6) to read as follows:

(6) All plug and slot welds in primary or secondary members.

SECTION 7
WELDING
Part B – Workmanship and Technique

704. GENERAL

The requirements of this section provide for welding of structural steels that have a minimum specified yield point not greater than 70 ksi. The steels to be welded are listed in Section 5, Base Metals. Higher strength steel or steels not listed in Section 5 will be subject to additional requirements as listed in the Contract Documents. When the Contractor proposes the use of a steel not listed in Section 5, additional requirements may be specified by the DCES during review and approval of the welding procedure specification.

All welders, welding operators and tackers shall be qualified by tests prescribed in Section 8, Qualification.

Section 4, General Fabrication Requirements, specifies fully automatic and semiautomatic welding for many applications. These requirements may preclude the use of specific welding processes in certain areas of the fabrication. All welding processes except manual shielded metal arc shall be qualified by a Procedure Qualification Report (PQR) test performed by the Contractor as required by Section 8, Qualification. A Welding Procedure Specification (WPS) shall be written based on acceptable PQR results.

All welding shall be performed in accordance with the provisions of a written WPS as shown in Figure 704. Prior to the start of welding, a WPS for each type of weld process and joint (i.e. fillet, PJP and CJP) shall be submitted and approved by the DCES. The welding procedure specifications shall be prominently displayed at the welding station. Joint welding procedures not prequalified shall be qualified by Welding Procedure Qualification Tests in accordance with the provisions of Section 2 of AWS D1.5 – 2002.

Welders shall be provided firm footing at all times. When it is necessary to weld from platforms above the ground, such platforms shall be rigidly braced to prevent movement of the platform during the welding operation.

All welding and thermal cutting equipment shall be designed and manufactured and shall be in suitable condition to enable qualified welders, welding operators, and tackers to follow the procedures and obtain the results required by these specifications.

Welding shall not be done when the ambient temperature is lower than 0°F, when surfaces are wet or exposed to rain, snow or high wind, or when welders or welding operators are exposed to inclement conditions. The reference to 0°F does not mean the ambient environmental temperature but the temperature in the immediate vicinity of the weld. The ambient environmental temperature may be below 0°F provided a heated structure or shelter around the area being welded maintains the air and base metal temperature adjacent to the weldment at 0°F or higher.

The sizes and lengths of welds shall be no less than those specified by the plans and shop drawings, nor shall they be substantially in excess of those requirements without approval of the DCES. The location of welds shall not be changed without prior approval.

BD 190 (4/81)

WELDING PROCEDURE SPECIFICATION

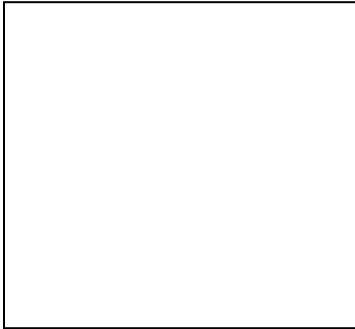

Material specification _____
 Welding process _____
 Manual, semi-automatic or automatic _____
 Position of welding _____
 Filler metal specification AWS _____
 Filler metal classification _____
 Electrode and manufacturer _____ FCM Lot # _____
 Flux and manufacturer _____ FCM Lot # _____
 Shielding gas _____ Dew point _____ Flow rate _____
 Single or multiple pass _____
 Single or multiple arc _____
 Welding current _____
 Polarity _____
 Welding progression _____
 Root treatment _____
 Preheat and interpass temperature _____
 Postheat treatment _____
 PQR# _____

WELDING PROCEDURE

Pass No.	Electrode Size	Welding parameters		Travel Speed	Joint Detail
		Amperes	Volts		

Sequence of weld passes shall be shown diagrammatically

Procedure no. _____ Fabricator or Erector _____
 Revision no. _____ Authorized by _____
 Date _____

FIGURE 704 – SAMPLE WELDING PROCEDURE SPECIFICATION

705. APPROVED WELDING PROCESSES

The following welding processes may be used for the fabrication of bridges, buildings and ancillary products:

- Manual Shielded Metal Arc Welding (SMAW)
- Submerged Arc Welding (SAW)
- Flux Cored Arc Welding-Gas Shielded (FCAW-G)
- Gas Metal Arc Welding (GMAW)

All SMAW shall be performed using low hydrogen electrodes as described in this Manual. When FCAW is used, carbon dioxide gas shielding shall be used unless otherwise approved by the DCES. When GMAW is used, only Spray or Pulse Spray transfer modes shall be used.

The contractor may propose alternative welding procedures to those mentioned above. It shall be solely at the State's discretion whether or not to evaluate or accept the proposal. If a proposed alternative procedure is accepted, the State reserves the right to limit locations where it may be used. The State also reserves the right to add qualification protocols as outlined in Section 8, and require added testing prior to acceptance. The extent of added qualification and testing required will be determined solely by the State, and shall be performed at no additional cost to the State.

706. FILLER METAL REQUIREMENTS

706.1 General. All welds shall be made using electrodes or electrodes with shielding media combinations that produce filler metal properties as specified in AWS D1.5, Table 4.1. The required filler CVN toughness for base metals having a yield stress of 50 ksi or lower shall be 20 ft-lbs @ -20°F. For base metals with a yield stress greater than 50 ksi, the required filler CVN toughness shall be 25 ft-lbs @ -20°F.

Partial penetration welds, fillet welds and complete joint penetration welds subject only to shear stresses may be produced using filler metals that have a yield stress less than the base metal provided the Charpy V-Notch toughness of the filler metal and the ductility of the filler metal meet all the requirements for complete joint penetration groove welds. The filler metal shall meet all stress requirements as determined by the DCES.

Under some conditions, filler metal with improved ductility is preferred to filler metal with yield stress that matches the base metal. Overmatching filler metal, i.e., where the filler metal is significantly stronger than the base metal, is undesirable. Overmatching filler metal can be one of the major contributors to lamellar tearing when weld residual stresses act upon the base metal in the short transverse, "z", direction. The DCES may disapprove welding electrodes, electrode flux combinations and grades of weld metal that will cause significant over matching.

All electrodes, wire and flux shall be packaged, dried and stored in accordance with the provisions of Sections 711 through 714. After filler metal has been removed from its original package or container, it shall be protected and stored so that its characteristics and welding properties are not affected.

706.2 Requirements for Weathering Steels. For ASTM A709 HPS 70W, welding shall be in accordance with the Guide Specification for Highway Bridge Fabrication with High Performance Steel, Third Edition, April 2011, except for the preheat requirements which shall be per Section 7 and Section 9 of the SCM as applicable or as approved by the DCES.

706.3 Manufacturer's Certification. When requested by the DCES or required by the Contract Documents, the Contractor or Fabricator shall furnish manufacturers' certifications that the electrodes or electrodes with shielding media combinations furnished meet the requirements of the Contract Documents. This certification provides only for the acceptance of the electrode and/or electrode flux

combination to the applicable AWS Classification. The approval to use the electrode or electrode with shielding media combinations shall be based on qualification in accordance with the provisions of Section 8, Qualification.

707. WELDING WEATHERING STEELS

Filler metal and electrodes shall meet the requirements of AWS D1.5 Table 4-2. Electrodes for HPS 70W materials shall be subject to approval by the DCES.

708. PREHEAT AND INTERPASS TEMPERATURE

708.1 General Requirements. All welding processes with the exception of electroslog and electrogas welding shall require that the steel be preheated and that interpass temperatures be maintained in accordance with Table 708. When welding a combination of base metals, the minimum preheat and interpass temperature shall be governed by the higher strength steel with the exception of welding to A709-50W which will govern.

When the base metal is below the temperature listed for the thickness and grade of steel being welded, it shall be preheated. For modification of preheat requirements for submerged arc welding with multiple electrodes, see Section 712.5. The preheat and interpass temperature shall be maintained so that the surfaces of the parts on which weld metal is deposited are at or above the minimum specified temperature for a distance equal to the thickness of the part being welded but not less than 3 inches both laterally and in advance of the welding, and in the thru thickness, "z", direction.

Preheat and interpass temperatures shall be sufficient to prevent crack formation. Temperatures above the minimum shown in Table 708 may be required for highly restrained welds. The maximum interpass temperature shall be specified on the Welding Procedure Qualification Record-BD 177 (12/80) and the Welding Procedure Specification-BD 190 (4/81).

Preheat and interpass temperatures combined with heat input during welding shall be such that the hardness of the heat affected zones does not exceed a Rockwell Hardness of C27.

All field welding shall be done with a preheat and interpass temperature of 250° F unless higher preheat and interpass temperatures are required by Table 708. Preheat requirements shall be waived for the welding of permanent metal forms, and stud shear connectors to portions of girder flanges subject only to compressive stress. The preheat for M.R and E.B. Bridge Bearings shall be 150°F and the welding passes shall be manipulated so that the temperature of the bearing material does not exceed 200°F. (see Standard Specifications 565-3.06).

Lateral gusset plates shall be welded to girder flanges using a minimum preheat and interpass temperature of 250° F, unless higher temperatures are required by Table 708.

Crack repair procedures shall provide for higher preheat temperatures, controlled interpass temperatures and post heating as approved by the DCES. The preheat requirement for the welding of transverse stiffeners to web plates of A709-50W (A588) steel up to ¾ inch in thickness may be reduced from the 100° F temperature required by Table 708 to 50° F provided welding is done by a fully automatic submerged arc process. The minimum welding heat input shall be 50 kilojoules per inch. When submerged arc welding equipment is used that welds both sides of a stiffener or a connection plate simultaneously, the total heat input from both welding arcs shall be 100 kilojoules per inch minimum.

708.2 Preheating for Tack Welding. There shall be no tack welding on steel that is not preheated to the minimum specified preheat and interpass temperature required by Table 708 unless the tack weld and the adjacent heat affected zones are completely remelted and incorporated in a subsequent submerged arc weld. When required by the DCES, the Contractor shall furnish macro etched specimens to demonstrate conformance with this requirement.

All temporary tack welds that are not remelted and incorporated into permanent welds shall be removed by grinding. The areas where tack welds are removed shall be magnetic particle inspected by the Contractor in accordance with the provisions of Section 18, Magnetic Particle Inspection. The QC Inspector may perform hardness tests to determine that areas harder than a Rockwell hardness of C27 are not allowed to remain in the work.

Crack repair procedures shall provide for higher preheat temperatures, controlled interpass temperatures and post heating as approved by the DCES.

The preheat requirement for the welding of transverse stiffeners to web plates of A709-50W (A588) steel up to ¾ inch in thickness may be reduced from the 100° F temperature required by Table 708 to 50° F provided welding is done by a fully automatic submerged arc process. The minimum welding heat input shall be 50 kilojoules per inch. When submerged arc welding equipment is used that welds both sides of a stiffener or a connection plate simultaneously, the total heat input from both welding arcs shall be 100 kilojoules per inch minimum.

TABLE 708 - MINIMUM PREHEAT AND INTERPASS TEMPERATURE

Thickness of Thickest Part at Point of Welding (inches)	ASTM A709-36, -50, A36 A53,A252, A500, A501, A572, A992	ASTM A709-50W, A588, A847 HPS 50W HPS 70W
To ¾, inclusive	50°F	100°F
Over ¾ to 1 ½, inclusive	70°F	200°F
Over 1 ½ to 2 ½, inclusive	150°F	300°F
Over 2 ½	225°F	350°F

709. HEAT INPUT REQUIREMENT FOR A709-50W (A588) AND A709-HPS70W STEELS

The minimum heat input during welding of A709-50W (A588) steel shall be 35 kilojoules per inch for material from ⅜ inch to ¾ inch in thickness and 50 kilojoules per inch for material over ¾ inch in thickness. The heat input for A709-HPS70W, regardless of material thickness, shall be a minimum of 40 kilojoules per inch and a maximum of 90 kilojoules per inch. The Contractor shall calculate the minimum and maximum welding heat inputs for various welding procedures and submit these values to the DCES for approval as part of the welding procedure specification.

710. STRESS RELIEF HEAT TREATMENT

Where required by the Contract Documents or approved as a part of a weld repair procedure welded assemblies shall be stress relieved by heat treating. Finish machining shall be done after stress relief. Stress relief heat treatment shall conform to the following requirements:

- a) The temperature of the furnace shall not exceed 600° F at the time the welded assembly is placed in it.
- b) Above 600° F, the rate of heating * shall not be more than 400° F per hour divided by the maximum metal thickness of the thicker part in inches, but in no case more than 400° F per hour.
- c) After a mean temperature range between 1100°F and 1200°F is reached, the temperature of the assembly shall be held within the specified limits for a time not less than specified in Table 710a, based on weld thickness. When the specified stress relief is for dimensional stability, the holding time shall not be less than specified in Table 710a based on the thickness of the thicker part. During the holding period there shall be no difference greater than 150°F between the highest and lowest temperature throughout the portion of the assembly being heated,
- d) Above 600°F cooling shall be done in a closed furnace or cooling chamber at a rate * no greater than 500°F per hour divided by the maximum metal thickness of the thicker part in inches, but in no case more than 500°F per hour. From 600°F, the assembly may be cooled in still air.
- e) When it is impractical to post heat to the temperature limitations stated in Table 710a, welded assemblies may be stress relieved at lower temperatures for longer periods of time as shown in Table 710b.

* The rates of heating and cooling need not be less than 100°F per hour. However, in all cases, consideration of closed chambers and complex structures may indicate reduced rates of heating and cooling to avoid structural damage due to excessive thermal gradients.

TABLE 710a – MINIMUM HOLDING TIME

¼ inch or less	Over ¼ inch through 2 inches	Over 2 inches
15 minutes	1 hour/inch	2 hours plus 15 minutes for each additional inch over 2

TABLE 710b – ALTERNATIVE STRESS-RELIEF HEAT TREATMENT

Decrease in temperature below minimum Specified temperature (°F)	Minimum holding time at Decreased temperature, (hours per inch of thickness)
50	2
100	3
150	5
200	10

711. REQUIREMENTS FOR MANUAL SHIELDED METAL ARC WELDING

711.1 Electrodes for Manual Shielded Metal Arc Welding. Electrodes for manual shielded metal arc welding (SMAW) shall conform to the requirements of the latest edition of AWS A5.1, Specification for Mild Steel Covered Arc Welding Electrodes, or to the requirements of AWS A5.5, Specification for Low Alloy Steel Covered Arc Welding Electrodes. Only classifications E7018, E7028, or E8018-C3 shall be used without the prior approval of the DCES.

All SMAW electrodes shall be furnished and remain in hermetically sealed containers until the electrodes are to be used or after opening the electrodes are immediately placed in a storage oven held continuously at a temperature of at least 250°F until used in the work.

E70XX electrodes not used within 4 hours and E80XX electrodes not used within 2 hours from the time they are removed from the sealed container or storage oven shall be redried for 2 hours minimum at a temperature between 450° F and 550° F, or shall be discarded and not used in the work. If the relative humidity is greater than 70%, the limits of 4 hours and 2 hours shall be reduced to 2 hours and 1 hour respectively.

Redrying of electrodes will only be permitted if the Contractor has the proper equipment for controlled drying at the temperatures specified above. Electrodes which have been wet shall not be redried or used under any condition. Electrodes redried once and then exposed to atmospheric conditions for a time greater than stated above shall be discarded and not used in the work.

711.2 Procedures for Manual Shielded Metal Arc Welding

711.2.1 General. The work shall be positioned for flat position welding whenever practical. The classification and size of electrodes, arc length, voltage, and amperage shall be suited to the thickness of the material, type of groove, welding positions, and other circumstances pertinent to the work. Welding current shall be within the range recommended by the electrode manufacturer.

711.2.2 Size of Electrodes. The maximum diameter of electrodes shall be as follows:

- a) 1/4 inch for all welds made in the flat position, except root passes.
- b) 1/4 inch for horizontal fillet welds.
- c) 3/16 inch for root passes of groove welds made in the flat position with backing and with an opening of 1/4 inch or more.
- d) 5/32 inch for welds made with low-hydrogen electrodes in the vertical and overhead positions.
- e) 3/16 inch for root passes of groove welds and for all other welds not included above.

711.2.3 Size of Weld Passes. The minimum size of a root pass shall be sufficient to prevent cracking. The maximum thickness of root passes in groove welds shall be 1/4 inch. The maximum size of single pass fillet welds and root passes of multiple pass fillet welds shall be:

- a) $\frac{3}{8}$ inch in the flat position.
- b) $\frac{5}{16}$ inch in the horizontal or overhead positions.
- c) $\frac{1}{2}$ inch in the vertical position.

The maximum thickness of layers subsequent to root passes of groove and fillet welds shall be:

- a) $\frac{1}{8}$ inch for subsequent layers of welds made in the flat position.
- b) $\frac{3}{16}$ inch for subsequent layers of welds made in the vertical, overhead, or horizontal positions.

711.2.4 Direction of Welding. The progression for all passes in vertical position welding shall be upward. However, when tubular products are welded, the progression of vertical welding may be upward or downward but only in the direction or directions for which the welder is qualified using the electrode classification and size approved by the DCES.

711.2.5 Gouging Root of Weld. Complete joint penetration groove welds made without the use of steel backing shall have the root gouged to sound weld metal and ground before welding is started from the second side.

711.2.6 Restrictions. E7028 electrodes shall not be permitted for use in the root pass of groove welds in any position.

711.2.7 Field Welding. All field welding shall be performed with either $\frac{5}{32}$ inch or $\frac{1}{8}$ inch diameter E7018 or E8018-C3 electrodes unless otherwise approved by the DCES.

712. REQUIREMENTS FOR SUBMERGED ARC WELDING

712.1 General. All welding procedures for submerged arc welding shall be qualified in accordance with the provisions of Section 8, Qualification. Submerged arc welding may be performed with one or more single electrodes, one or more parallel electrodes, or combinations of single and parallel electrodes. The spacing between arcs shall be such that the slag cover over the weld metal produced by a leading arc does not cool sufficiently to prevent the proper weld deposit of a following electrode. Submerged arc welding with multiple electrodes may be used for any groove or fillet weld pass.

The following paragraphs governing the use of submerged arc welding apply to any steel included in Section 5, Base Metals. Consideration shall be given to the additional heat input produced by simultaneous welding on two sides of a common member. Electrode spacing, orientation, and weld travel speed shall be regulated to prevent bridging (undesirable base metal melting beyond the weld) and attendant hot cracking.

The diameter of electrodes shall not exceed $\frac{1}{4}$ inch.

Surfaces on which submerged arc welds are to be deposited and adjacent faying surfaces shall be clean and free of moisture as specified in Section 6, Preparation of Base Metal.

All welds for bridges detailed as complete joint penetration groove welds and not required to be fused into steel backing shall have the root of the initial (first side) weld air carbon arc gouged to sound weld metal and ground before welding the second side.

When welds for buildings or welds designed to transmit only shear stresses in bridges require a specific root penetration, the Contractor shall make a sample joint and provide a macroetched cross section to demonstrate that the proposed welding procedure will obtain the required root penetration without back gouging. The DCES may accept a radiograph of a test joint or recorded evidence in lieu of the test specified in this paragraph. Nondestructive tests may be employed to assure penetration is achieved in the work.

Roots of groove welds and fillet welds may be backed by temporary steel bars meeting the requirements of Section 5, Base Metal, if necessary to prevent melting through. The DCES will consider joint design changes that make temporary steel backing unnecessary. Roots of groove and fillet welds may be sealed by means of root passes deposited with SMAW low hydrogen electrodes or by other approved welding processes. All temporary backing shall be removed and the surfaces finished flush unless otherwise approved by the DCES.

Neither the depth nor the maximum width in the cross section of weld metal deposited in each weld pass shall exceed the width of the surface of the weld pass (See Figure 712.1). This requirement may be waived only if the testing of a welding procedure has demonstrated to the satisfaction of the DCES that such welds are free from cracks. The welding procedure and the electrode flux combination used in the tests shall be the same as that used in construction.

Tack welds which will be incorporated in fillet welds $\frac{3}{8}$ inch or smaller or in the root of joints requiring specific root penetration shall be sufficiently small to insure that they do not produce objectionable changes in the appearance of the weld surface or result in a decrease in penetration. If it is anticipated that either situation may occur, they shall be removed or reduced in size in accordance with Section 726, Repairs, prior to welding.

Tack welds in the root of a joint with steel backing less than $\frac{5}{16}$ inch thick shall be removed or made continuous for the full length of the joint using low hydrogen electrodes.

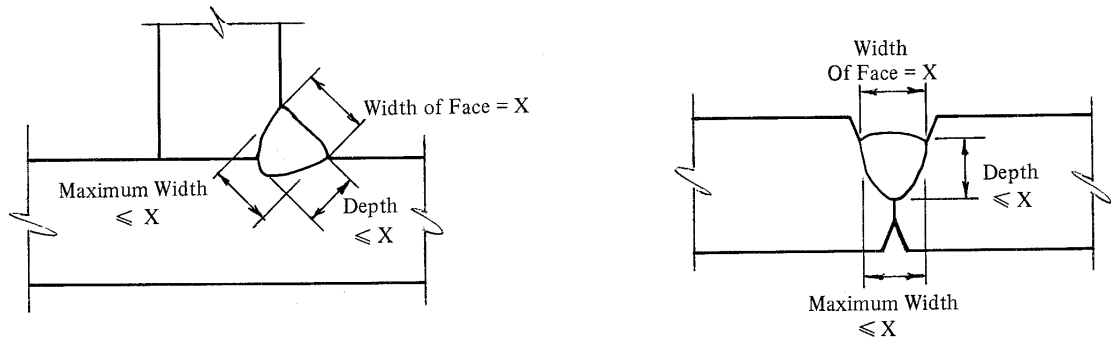

Figure 712.1 WELD PASS RATIO

712.2 Electrodes and Fluxes for Submerged Arc Welding. The bare electrodes and fluxes used in combination for submerged arc welding shall conform to the requirements of the latest edition of AWS A5.17, Specification for Bare Carbon Steel Electrodes and Fluxes for Submerged Arc Welding or to the requirements of the latest edition of AWS A5.23, Specification for Bare Low-Alloy Steel Electrodes and Fluxes for Submerged Arc Welding.

The classification shall be as listed in AWS D1.5.

A shop welded procedure qualification test described in Section 8, Qualification shall demonstrate that the electrode flux combination will produce the required weld metal properties as listed in AWS D1.5.

When weathering steels are used, chemical analysis of the deposited weld metal shall verify conformance with the requirements of AWS D1.5.

If required by Section 706.3, the Contractor shall furnish manufacturer's certifications or certified copies of the test results performed by the manufacturer that demonstrate the electrode and flux combination meets the requirements of the Contract Documents.

Flux used for submerged arc welding shall be dry and free of contamination from dirt, mill scale or other foreign matter. All flux shall be purchased in packages that can be stored, under normal conditions for at least 6 months without affecting its welding characteristics or weld properties.

Flux from damaged packages shall be discarded or shall be dried at a minimum temperature of 500° F for one hour before use. Flux shall be placed in the dispensing system immediately upon opening the package. If flux is used from an open package a minimum of 1 inch of the surface flux shall be discarded before the remainder is used. All flux in welding equipment, hoppers, tanks, etc. shall be replaced with new or freshly dried flux whenever welding operations have not been conducted for more than 48 hours. Flux that has been wet shall not be used.

Flux fused in welding shall not be reused. Flux that has not been melted during welding operations may be reused after recovery from the weldment surface only by vacuuming, use of catch pans or sweeping. Recovered flux shall be passed through an appropriate screen and over a suitable magnet to remove unwanted particles and materials before being returned to the flux supply system. Flux that is not reclaimed from the weldment surfaces within one (1) hour of being deposited of the weld shall be discarded. Fluxes shall not be recycled a sufficient number of times to permit segregation of the flux or loss of component sizes such that welding characteristics or weld properties may be modified. The percentage of new to recycled flux shall be a minimum of 33%.

712.3 Procedures for Submerged Arc Welding with a Single Electrode. Single electrode means one electrode connected exclusively to one power source which may consist of one or more power units.

All submerged arc welds except fillet welds shall be made in the flat position. Fillet welds may be made in either the flat or horizontal position, except that single pass fillet welds made in the horizontal position shall not exceed $5/16$ inch.

The thickness of weld layers, except root and surface layers, shall not exceed $1/4$ inch. When the root opening is $1/2$ inch or greater, a multiple pass, split-layer technique shall be used. The split-layer technique shall also be used in making multiple pass welds when the width of the layer exceeds $3/8$ inch.

The welding current, arc voltage, and travel speed shall be such that each pass shall have complete fusion with the adjacent base metal and weld metal and there will be no overlap or undue undercutting. The maximum welding current to be used when making any pass of a groove weld that has fusion to both faces of the groove shall be 600 amps, except that the final layer may be made using a higher current. The maximum current to be used when making fillet welds in the flat position shall be 1000 amps.

712.4 Procedures for Submerged Arc Welding with Parallel Electrodes. Parallel electrodes means two electrodes connected electrically in parallel exclusively to the same power source. Both electrodes are usually fed by means of a single electrode feeder. The welding current shall be the total for the two electrodes.

Submerged arc welds made with parallel electrodes, except fillet welds, shall be welded in the flat position. Fillet welds may be made in either the flat or horizontal position, except that single pass fillet welds made in the horizontal position shall not exceed $5/16$ inch.

The thickness of weld layers is not limited. Single or parallel electrodes may be used for the root pass of groove welds. Backing bars or root faces shall be of adequate thickness to prevent melting thru.

When the width of a surface in a groove on which a layer of weld metal is to be deposited exceeds $\frac{1}{2}$ inch, parallel electrodes shall be displaced laterally or a split layer technique used to assure adequate corner fusion. When the width of a previously deposited layer exceeds $\frac{5}{8}$ inch, a split layer technique with electrodes in tandem shall be used.

The welding current, arc voltage, travel speed, and relative location of electrodes shall be such that each pass will have complete fusion with the adjacent base metal and weld metal, and there will be no depressions or undue undercutting at the toe of the weld. Excessive concavity of initial passes shall be avoided to prevent cracking in the roots of joints under restraint.

The maximum welding current for making groove welds shall be:

- a) 700 amps for parallel electrodes when making the root layer in a groove having no root opening, and which does not fill the groove.
- b) 900 amps for parallel electrodes when making the root pass in a groove having steel backing.
- c) 1200 amps for parallel electrodes for all other passes except the final layer.
- d) For the final layer, there is no restriction on welding current.

The maximum welding current to be used in making a fillet weld shall be 1200 amps for parallel electrodes.

Preheat and interpass temperatures for parallel electrode submerged arc welding shall conform to the provisions of Table 708.

The DCES may approve reductions in preheat for certain applications of parallel electrode submerged arc welding provided acceptable weld and heat affected zone hardness test results are obtained during qualification testing and in verification testing during the work. The total welding heat input shall be computed based on all welding variables and the number of arcs operating simultaneously. The combination of preheat, interpass temperature and welding heat input shall be such that tests demonstrate that no portion of the heat affected zone has a Rockwell hardness greater than C25 or a Vickers hardness number greater than 266. Determination of the heat affected zone hardness shall be made on the initial macro etched cross sections of sample test welds and on the surface of weldments during the progress of the work. * Surfaces shall be ground to a finish of 60 microinches or smoother in areas that are to be hardness tested. Tests shall be made on the thicker metal in each weld joint at a rate of not less than one test per weldment, or one test each 50 feet of groove weld, each pair of fillet welds made simultaneously, or each fillet weld. Hardness testing may be reduced in frequency or discontinued after the procedure has been established to the satisfaction of the DCES.

No reduction of the preheat requirements listed in Table 708 will be permitted for fillet or groove welds $\frac{3}{8}$ inch and under in size.

*The Vickers hardness number shall be determined in accordance with the requirements of ASTM E92. Rockwell hardness numbers shall be determined in accordance with the provisions of ASTM E18.

712.5 Procedures for Submerged Arc Welding with Multiple Electrodes. Multiple electrodes are defined as the combination of two or more single or parallel electrode systems. Each of the component systems has its own independent power source and its own electrode feeder.

Submerged arc welds with multiple electrodes, except fillet welds, shall be made in the flat position. Fillet welds may be made in either the flat or horizontal position, except that single pass multiple electrode fillet welds made in the horizontal position shall not exceed $\frac{1}{2}$ inch.

The thickness of weld layers is not limited. A single or multiple electrode may be used to make the root pass of groove welds. Backing bars or root faces shall be of adequate thickness to prevent melting thru. When the width of a surface in a groove on which a layer of weld metal is to be deposited exceeds $\frac{1}{2}$ inch, a split layer technique shall be used to assure adequate corner fusion. When the width of a

previously deposited layer exceeds 1 inch, and only two electrodes are used, a split layer technique with electrodes in tandem shall be employed.

The welding current, arc voltage, travel speed and relative location of electrodes shall be such that each pass will have complete fusion with the adjacent base metal and weld metal and there will be no depressions or undue undercutting at the toe of the weld. Excessive concavity of initial passes shall be avoided to prevent cracking in roots of joints under restraint.

The maximum welding current when making a groove weld shall be:

- a) 700 amps for any single electrode or for parallel electrodes when making the root layer in a groove having no root opening and which does not fill the groove.
- b) 750 amps for any single electrode or 900 amps for parallel electrodes when making the root pass in a groove weld having steel backing.
- c) 1000 amps for any single electrode or 1200 amps for parallel electrodes for all other passes except the final layer.
- d) For the final layer, there is no restriction on welding current.

Welding procedures using currents higher than listed in c) above shall be subject to qualification testing as determined by the DCES. The maximum welding current to be used for making a fillet weld shall be 1000 amps for any single electrode or 1200 amps for parallel electrodes. Preheat and interpass temperatures for multiple electrode submerged arc welding shall conform to the provisions of Table 708.

The DCES may approve reductions in preheat for certain applications of multiple electrode submerged arc welding, provided acceptable weld and heat affected zone hardness test results are obtained during qualification testing and in verification testing during the work. The total welding heat input shall be computed based upon all welding variables and the number of arcs operating simultaneously. The combination of preheat, interpass temperature and welding heat input shall be such that tests demonstrate that no portion of the heat affected zone has a Rockwell hardness greater than C 25 or a Vickers hardness number greater than 266. Determination of the heat affected zone hardness shall be made on the initial macroetched cross sections of sample test welds and on the surface of weldments during the progress of the work. *Surfaces shall be ground to a finish of 60 microinches or smoother in areas that are to be hardness tested. Tests shall be made on the thicker metal in each weld joint at a rate of not less than one test per weldment, or one test each 50 feet of groove weld, each pair of fillet welds made simultaneously, or each fillet weld. Hardness testing may be reduced in frequency or discontinued after the procedure has been established to the satisfaction of the DCES.

No reduction of the preheat requirements listed in Table 708 *Minimum Preheat And Interpass Temperature* will be permitted for fillet welds or groove welds $\frac{3}{8}$ inch and under in size.

713. REQUIREMENTS FOR FLUX CORED AND GAS METAL ARC WELDING

713.1 Electrodes. Electrodes and shielding (when required) for FCAW and GMAW shall conform to the requirements of the latest edition of AWS A5.18, Specification for Carbon Steel Filler Metals and Rods, AWS A5.20, Specification for Carbon Steel Electrodes for Flux Cored Arc Welding or AWS A5.29, Specification for Low-Alloy Steel Electrodes for Flux Cored Arc Welding. The classification of the electrode shall meet the requirements of AWS D1.5.

The shielding gas or gas mixture used for GMAW or FCAW, when required, shall be of a welding grade having a dew point of -40°F or lower. The Contractor shall furnish the gas manufacturer's certification that the gas or gas mixture is suitable for the intended application and will meet the dew point requirement.

713.2 Procedures for FCAW and GMAW. A shop welded PQR test, as described in Section 8 Qualification, shall demonstrate that the electrode-shielding gas combination or the electrode will produce the required weld metal properties as listed in AWS D1.5.

The shielding for FCAW and GMAW shall be carbon dioxide gas unless otherwise approved by the DCES.

The electrodes shall be received in suitable containers to insure that they are dry and in suitable condition for use. The maximum electrode diameter shall be $\frac{5}{32}$ inch for welding in the flat and horizontal positions, $\frac{3}{32}$ inch for welding in the vertical position, and $\frac{5}{64}$ inch for welding in the overhead position.

The maximum size fillet weld to be made in one pass shall be $\frac{1}{2}$ inch for flat and vertical welding, $\frac{3}{8}$ inch for welding in the horizontal position, and $\frac{5}{16}$ inch for welding in the overhead position.

The thickness of weld layers, except root and surface layers, shall not exceed $\frac{1}{4}$ inch.

When the root opening of a groove weld is $\frac{1}{2}$ inch or greater, a multipass split layer technique shall be used. The split layer technique shall also be used in making all multiple pass welds when the width of the layer exceeds $\frac{5}{8}$ inch for flat, horizontal and overhead welding or 1 inch for vertical welding. The welding current, arc voltage, gas flow rate, mode of metal transfer, and travel speed shall be adjusted so that each pass will have complete fusion with adjacent base metal and weld metal and meet the requirements of this Manual.

The progression of all passes for vertical welding shall be upward. In tubular structures, the progression of passes for vertical welding may be upward or downward, but only in the direction for which the welder and welding process is qualified.

FCAW-G and GMAW shall not be done in a draft or wind unless the weld is protected by a shelter. The shelter shall be suitably constructed to reduce the velocity of the wind in the vicinity of the weld to a maximum of five miles per hour.

To prevent melting thru, roots of groove or fillet welds may be backed by steel bars if necessary as described in Section 712.1. Roots of groove or fillet welds may be sealed by means of root passes deposited by manual shielded metal arc welding using E 7018 electrodes.

714. EXTENSION BARS AND RUNOFF PLATES

Welds shall be terminated at the end of a joint in a manner that will insure sound welds. Whenever possible, this shall be done by the use of extension bars and runoff plates placed in a manner that will duplicate the joint detail being welded.

Extension bars and runoff plates used in bridge construction shall be removed upon completion of the weld joint. The ends of the weld shall be ground smooth and flush with the abutting parts.

Extension bars and runoff plates used in building construction shall be removed at the completion of welding unless otherwise approved by the Engineer. Extension bars and runoff plates shall conform to the requirements of Section 504.

715. GROOVE WELD BACKING

Unless otherwise approved by the DCES, only steel may be used as groove weld backing. DCES may approve the use of ceramic backing in limited applications. Groove welds made with the use of steel backing shall have the weld metal thoroughly fused to the backing. The steel backing shall be made continuous for the full length of the weld. All necessary joints in the steel backing shall be complete joint penetration groove welds meeting all the workmanship requirements of Section 7. Weld backing shall conform to the requirements of Section 504. The minimum thickness of the backing shall be $\frac{3}{8}$ inch.

715.1 Bridge Structures. On bridge structures, steel backing of welds transverse to the direction of computed stress shall be removed and the joints shall be ground flush. Steel backing of welds that are parallel to the direction of stress or not subject to computed stress need not be removed unless specified in the Contract Documents or ordered by the DCES.

When the steel backing of longitudinal welds in bridge structures is permitted to be externally attached to the base metal by welding, the welds shall be continuous for the length of the backing. Backing may be left in place on tee and corner welds unless otherwise specified.

715.2 Buildings and Tubular Structures. Steel backing of welds used in buildings or tubular structures need not be removed unless specified in the Contract Documents or ordered by the DCES.

716. TEMPORARY AND TACK WELDS

Temporary and tack welds shall be subject to the same quality requirements as final welds except:

- a) Preheat is not mandatory except when using FCAW and GMAW for single pass tack welds which are completely remelted with their attendant heat affected zones and incorporated into final submerged arc welds.
- b) Discontinuities such as undercut, unfilled craters and minor porosity need not be removed before the final submerged arc weld, if such welds are to be remelted.
- c) The minimum length of the tack welds shall be at least four times the nominal weld size, or 1 ½ inches, whichever is greater, unless otherwise approved by the DCES.
- d) The maximum length of the tack weld shall be 10 inches in every 5 foot of weld length unless otherwise approved by the DCES.

Tack welds which are incorporated into final welds shall be made with electrodes approved for use in the approved welding procedure specification.

Tack welds shall be thoroughly cleaned before final welding. Multiple pass tack welds shall have cascaded ends.

Tack welds larger than permitted in Section 712.1 shall be reduced in size by grinding before final welding is begun.

Tack welding of steel shall be done within the joint so that all tack welds will be remelted and incorporated within the final weld.

Temporary or tack welds which are not incorporated into the final weld shall be removed and the surface shall be finished flush with the original surface. The areas where the welds were removed shall be magnetic particle inspected by the Contractor in accordance with the provisions of Section 18, Magnetic Particle Inspection.

The Inspector shall perform hardness tests on the weld removal areas. Areas found to be harder than Rockwell hardness C 30 will not be accepted. Localized hard spots may be removed by grinding as approved by the DCES.

There shall be no temporary attachments by welding to tension areas of any structural steel unless approved by the DCES.

All temporary welds, when approved, shall meet all quality requirements of the specifications for permanent welds including preheat, interpass temperature, and minimum heat input controls. Temporary welds shall be removed and the surface finished flush as described in this Section.

Tack welds, when approved to attach permanent metal forms to compression areas of girder flanges, shall be subject to the above requirements, except that preheat is not mandatory. Tack welds will not be permitted on girder flanges, in areas subject to tension or reversal stress. Areas of tension or reversal stress will generally be shown on the plans. (See Section 203.4 for definition of stress reversal zone.)

717. CONTROL OF DISTORTION AND SHRINKAGE STRESSES

When assembling and joining parts of structures, built-up members, or welding reinforcing parts to members, the procedure and sequence shall minimize distortion and shrinkage stresses. All welds shall be deposited in a sequence that will balance the applied heat of welding and shrinkage stresses while the welding progresses. Complete welding of the first side of a groove weld preparation before welding the second side may cause unacceptable distortion.

The Contractor shall develop welding procedures which, in conjunction with the overall fabrication methods, will produce members and structures that meet the dimensional and quality requirements of the Contract Documents. These procedures and any revisions necessary in the course of the work shall be sent for information and comment to the DCES.

The direction of the general progression of welding on a member shall be from points where the parts are relatively fixed in position with respect to each other toward points where they have a greater relative freedom of movement. Joints expected to have significant shrinkage should usually be welded before joints expected to have less shrinkage. Joints should be welded with as little restraint as possible.

All shop splices in each component part of a cover plated beam or builtup member shall be made before the component part is welded to other parts of the member. Long girders may be made by shop splicing subsections made in accordance with this paragraph.

Welds made under conditions of severe external shrinkage restraint shall be welded continuously to completion or to a point that will insure freedom from cracking before the joint is allowed to cool below the minimum specified preheat and inter pass temperature.

Joint details may be modified to reduce total shrinkage and control distortion in accordance with Section 702.

718. PEENING

With approval of the DCES, peening will be permitted on intermediate weld layers of large multipass welds and repair welds to control shrinkage stresses and prevent cracking. No peening shall be done on the root or surface layer of the weld. The peening tool shall be rounded to a ¼ inch minimum radius at the striking end. The Contractor shall submit the peening procedure to the DCES for approval before beginning the work. Care shall be taken to prevent overlapping or cracking of the weld or base metal. No procedure or equipment will be permitted that will allow moisture, oil, or other materials to contaminate the weld joint. All peening energy shall be directed against the convex surface of the weld beads. No peening of base metal or of the fusion boundaries will be permitted. Peening may only be done when the weld is between 150°F minimum and 550°F maximum.

719. ARC STRIKES

Arc strikes outside the area of permanent welds shall be avoided. Blemishes caused by arc strikes shall be ground flush and smooth. The area shall be visually inspected and magnetic particle or dye penetrant tested to insure soundness. Cracks shall be reported to the DCES and repaired as described in Section 726. The QC Inspector shall perform hardness tests in arc strike areas. Areas found harder than a Rockwell hardness of C 30 shall be repaired as approved by the DCES.

720. CAULKING

Caulking is defined as the plastic deformation of weld and base metal surfaces by mechanical means to seal or obscure discontinuities. Caulking shall not be permitted.

721. WELD CLEANING

721.1 In Process Cleaning. All slag shall be removed and the weld and adjacent base metal shall be brushed clean before welding over previously deposited metal. This requirement shall apply not only to successive layers, but also to successive beads and to the crater area when welding is resumed after any interruption. The provisions of this section shall not restrict the welding of plug and slot welds, when required by the plans and performed in accordance with procedures approved by the DCES.

721.2 Cleaning of Completed Welds. Slag shall be removed from all completed welds, and the weld and the adjacent base metal shall be cleaned of all weld spatter, fume deposits and other surface contaminants. Welded joints that are to be painted shall not be painted until the work has been completed and accepted.

722. WELD PROFILES AND FILLET WELD SIZES

Unless an exception is specifically approved by the DCES, the maximum fillet weld size shall be limited to 5/8". If design considerations would mandate a larger fillet weld size, full penetration groove welds shall be used. The faces of fillet welds may be slightly convex, flat or slightly concave as shown in Figure 723 (A) & (B). Profiles shown in Figure 723 (C) shall not be allowed.

Fillet welds shall be permitted to underrun the nominal fillet size specified by 1/16 inch without correction provided the undersize portion of the fillet welds does not exceed 10% of the length of the weld. On web to flange welds of plate girders, no underrun is permitted at the ends for a length equal to the depth of the girder.

The maximum allowable oversize for fillet welds shall be 3/32" larger than the specified size. Corrections, when necessary, will be limited to reducing the weld size as described in Section 725.2 and/or correcting the distortion. The soundness of the weld and adjacent base metal shall be evaluated by magnetic particle testing after repairs are completed.

All butt welded joints subject to NDE inspection as described in Section 16 and/or Section 17 shall be ground smooth on all four sides (if applicable) before being tested.. Other joints may be finished leaving some

reinforcement provided all surface lines have been removed by grinding and reinforcement does not exceed the requirements of Table 723 *Weld Reinforcement*.

The finish grinding need not be parallel to the direction of stress in the joint provided the surface roughness is less than ANSI 125.

The reinforcement need not be equally distributed on each side of the joint provided it does not exceed the amount shown in Table 723 *Weld Reinforcement*. No weld reinforcement will be permitted on the side of a joint that is a faying surface, contact surface, or exposed web surface of a fascia girder. All butt welds not subject to radiographic inspection or grinding to produce flush surfaces shall be made with slight or minimum reinforcement and shall have none of the defects shown in Figure 723(E). The height of reinforcement shall not exceed $\frac{1}{8}$ inch on any side of a joint and shall have a gradual transition to the base metal surface. When located at the inter-section of a web butt (splice) weld and a compression flange, the final 1 inch of the web butt weld shall be ground.

Care shall be taken to insure that welds in shapes and plates are not ground below the ordered thickness. Small localized reductions in section thickness not to exceed 10% of the length of the weld will be permitted provided the reduction is not more than 5% of the ordered thickness of the thinner piece. General undergrinding shall not exceed 0.010 in. [0.25 mm] below the ordered thickness. Sections ground below these limits shall be rewelded and if the original weld joints calls for radiographic inspection, they shall be reradiographed.

Undercut shall not be greater than 0.010 inch deep when the weld is transverse to the direction of primary stress. Undercut shall not exceed $\frac{1}{32}$ inch deep for all other cases. The DCES may approve localized undercut greater than $\frac{1}{32}$ inch deep in parts not subjected to calculated stress.

Welds shall be free from overlap.

TABLE 723 - WELD REINFORCEMENT

Plate Thickness (inches)	Thickness of Reinforcement (inches)
To $\frac{3}{4}$, inclusive	none, grind flush
Over $\frac{3}{4}$ to 1, inclusive	$\frac{3}{64}$ each side or $\frac{3}{32}$ total
Over 1 to 2, inclusive	$\frac{1}{16}$ each side or $\frac{1}{8}$ total
Over 2 to 3, inclusive	$\frac{3}{32}$ each side or $\frac{3}{16}$ total
Over 3	$\frac{1}{8}$ each side or $\frac{1}{4}$ total

723. QUALITY OF WELDS (Bridges)

723.1 Visual Inspection. All welds shall be visually inspected. A weld shall be acceptable by visual inspection if:

- a) The weld has no cracks.
- b) Thorough fusion exists between adjacent layers and passes of weld metal and between weld metal and base metal.
- c) All craters are filled to the full cross section of the weld.
- d) Weld profiles are in accordance with the provisions of Section 722.
- e) Undercut is less than described in Section 722.
- f) Porosity does not exceed the provisions of Section 723.3.
- g) The size of fillet welds meets the requirements of Section 722.

Visual inspection of welding shall be performed before, during, and after completion of the welding. Final visual inspection of welds shall be performed after blast cleaning as noted in Section 13.

723.2 Other Nondestructive Inspection. Welds that are subject to nondestructive testing other than visual inspection of the weld in process, on the surface of the completed weld, or in the cross section of a milled end required by design, shall meet all the requirements for welds visually inspected as described above and shall also conform to the standards of acceptance described in Section 16, Radiographic Testing, Section 17, Ultrasonic Testing, Section 18, Magnetic Particle Inspection, or Section 19, Dye Penetrant Inspection, as provided in the Contract Documents. Testing may begin immediately after the completed welds have cooled to ambient temperatures unless otherwise specified.

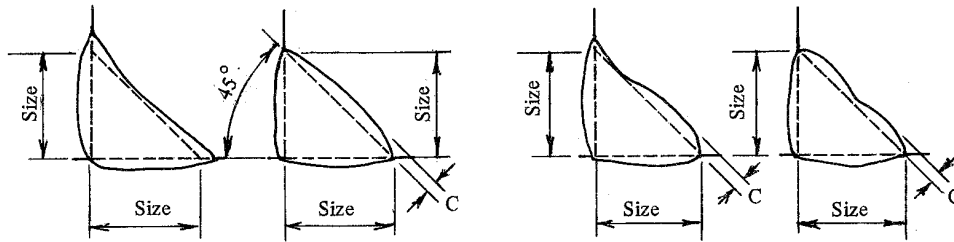

Note: Convexity, C, of a weld or individual bead shall not exceed 0.07 times the actual face width of the weld or individual bead, respectively, plus 0.06 inches.

(A) Desirable fillet weld profiles

(B) Acceptable fillet weld profiles

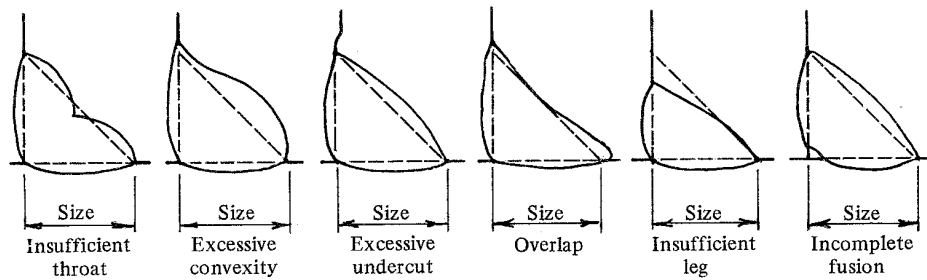

(C) Unacceptable fillet weld profiles

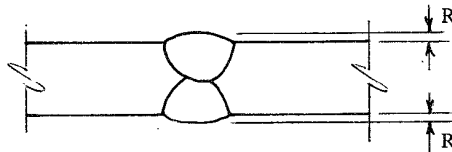

Note: Reinforcement R shall not exceed 1/8 inch.

(D) Acceptable butt weld profile

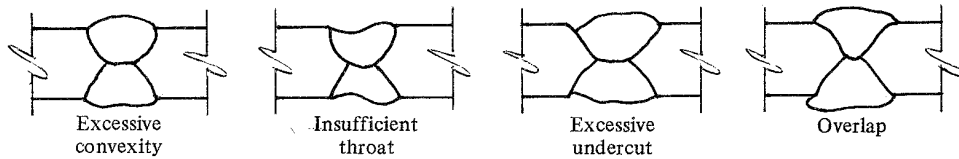

(E) Unacceptable butt weld profiles

FIGURE 723 – ACCEPTABLE AND UNACCEPTABLE WELD PROFILES

723.3 Limits of Porosity.

- a) Fillet Welds. The frequency of piping porosity in the surface of fillet welds shall not exceed one in four inches or six in four feet of weld length and the maximum diameter shall not exceed $\frac{3}{32}$ inch.

Since piping porosity does not have to extend to the surface of the weld to present a serious structural defect, a subsurface inspection for porosity shall be required by the Inspector whenever piping porosity $\frac{3}{32}$ inch or larger in diameter extends to the surface at intervals of 12 inches or less over a distance of four feet, or when the condition of electrodes, flux base metal, or the presence of weld cracking indicates that there may be a problem with piping or gross porosity. This sub-surface inspection shall be a visual inspection of 12 inch long sections of the fillet weld throat after it has been ground or removed by air carbon arc gouging to a depth of one-half the design throat. When viewed at the mid throat of the weld, the sum of the diameters of all porosity shall not exceed $\frac{3}{8}$ inch in any linear inch of weld or $\frac{3}{4}$ inch in any 12 inch length of weld.

- b) Groove Welds. Complete joint penetration groove welds in butt joints transverse to the direction of computed tensile stress shall have no piping porosity. For all other groove welds the frequency of piping porosity shall not exceed one in four inches or six in four feet of weld length and the maximum diameter shall not exceed $\frac{3}{32}$ inch.

Groove welds displaying piping porosity at the surface which exceeds the values permitted under paragraph a) above shall be excavated by air carbon arc gouging or grinding to one-half the depth of the groove preparation that was welded. When viewed at the mid groove depth, the sum of the diameters of all porosity shall not exceed $\frac{3}{16}$ inch in any linear inch of weld or $\frac{3}{8}$ inch in any 12 inch length of weld.

724. QUALITY OF WELDS (Buildings)

All welds shall be visually inspected. A weld subject only to visual inspection that meets the visual inspection requirements for bridge welds shall be acceptable.

In general, undercut twice the amount allowed in bridge welds will be permitted. The DCES may approve undercut greater than $\frac{1}{16}$ inch deep in members not subject to calculated stress or subject only to compressive stress.

Welds subject to radiographic testing shall meet the building quality requirements of Section 16. Welds subject to ultrasonic testing shall meet the minimum acceptance levels for welds in buildings as listed in Section 17. Welds subject to magnetic particle or dye penetrant testing shall conform to the requirements of Section 18 & 19 respectively.

Visual inspection of welding shall be performed before, during, and after completion of the welding. Other nondestructive testing of welds may begin immediately after the completed welds have cooled to ambient temperature unless otherwise specified.

725. REPAIRS

725.1 General. The removal of weld metal or portions of the base metal may be done by machining, grinding, chipping, or air carbon arc gouging. It shall be done in such a manner that the remaining weld metal or base metal is not nicked or undercut. Unacceptable portions of the weld shall be removed without substantial removal of the base metal.

Additional weld metal, to compensate for any deficiency in size, shall be deposited using an electrode preferably smaller than that used to make the original weld but not less than $\frac{5}{32}$ inch in diameter. The

surfaces shall be cleaned thoroughly before welding. Minimum preheat and interpass temperatures, and minimum welding heat input requirements shall be observed.

When air carbon arc gouging is used, it shall be followed by grinding to remove carbon pickup.

725.2 Written Repair Procedures. Written repair procedures shall be submitted on full size drawings * to fully describe the deficiency and the proposed method of repair. The drawings shall be prepared by the Contractor and submitted to the DCES for approval, when any of the following conditions exist:

- a) Defective base metal, including lamellar tears.
- b) Excessive number of weld defects listed in Section 724 in anyone member, as determined by the DCES.
- c) Any delayed or cold crack in weld or base metal.
- d) Any weld or base metal crack other than an occasional root pass crack that occurred before it was possible to make the next weld pass.
- e) Heat-shrink procedures used to increase the camber of welded plate girders. (See Section 1502.3). Repairs to electroslog or electrogas welds with internal defects.
- g) Revised design to compensate for deficiencies.
- h) Members repair welded or modified to correct fabrication errors in cutting, punching, drilling, fitting, etc.
- i) Members which must be cut apart and rewelded or modified in any way due to fit-up or welding errors.

* In lieu of full size drawings, the DCES may approve repair sketches that have been verified by our Inspector.

725.3 Methods of Repair. The Contractor shall have the option of either repairing an unacceptable weld, removing and replacing the entire weld when approved by the DCES, or replacing the entire weldment. The repaired or replaced weld or replaced weldment shall be tested by the method originally used. The same technique and quality acceptance criteria shall be applied.

If the Contractor elects to repair the weld, it shall be repaired as follows:

- a) Overlap or excessive convexity shall be repaired by removing excess weld metal by grinding.
- b) Excessive concavity of welds or craters, undersize welds, or undercutting shall be repaired by cleaning and depositing additional weld metal after heating to the minimum preheat temperature.
- c) Excessive weld porosity, excessive slag inclusions, incomplete fusion or overlap not correctable by grinding shall be repaired by removing defective portions and rewelding. *In lieu of full size drawings, the DCES may approve repair sketches. When ordered by the DCES, the Contractor shall reproduce approved repair sketches on full size drawings so that they may be filed with the As-Built Plans.
- d) Cracks in weld or base metal shall be repaired by the following procedure: Determine the extent of the crack by use of magnetic particle testing or other equally positive means approved by the DCES. Remove the crack and sound metal two inches beyond each end of the crack and reweld in accordance with the approved repair procedure.
- e) Members distorted by welding may be straightened by heat-shrink straightening procedures as described in Section 15.
- f) Where work performed subsequent to making a defective weld has rendered the weld inaccessible or has caused new conditions which would make the correction of the deficiency dangerous or ineffective, the original condition shall be restored by removing weld members, or both before making corrections, or the deficiency shall be compensated for by additional work done in accordance with a design revision approved by the DCES.

SECTION 7 WELDING

Part C – Stud Welding

The New York State Steel Construction Manual adopts AASHTO/AWS D1.5: Bridge Welding Code, Section 7, Stud Welding, with the following modifications:

On page 157 of AASHTO/AWS D1.5M/D1.5: 2002, add a NEW Section 7.5.4.3 as follows:

7.5.4.3 The installation of new shear studs to existing steel, such as Type A7, may require preheat. When required, preheat shall be done in accordance to the contract documents.

On page 158 of AASHTO/AWS D1.5M/D1.5: 2002, Bridge Welding Code, replace Section 7.5.5.6 as follows:

7.5.5.6 The fillet welds meet all the weld quality requirements of Sections 724 and 725 of the SCM.

On page 159 of AASHTO/AWS D1.5M/D1.5: 2002, Bridge Welding Code, replace Section 7.7.1 as follows:

7.7.1 QUALITY CONTROL

Shear Connectors. The first two stud shear connectors welded on each member, after being allowed to cool, shall be tested by bending to an angle of 30 degrees from their original axes by striking the studs with a two pound hammer. If failure occurs in the weld zone of either stud, the procedure shall be corrected and two more studs shall be welded to the member and tested. If either of the second two studs fail, additional welding shall be continued on separate plates of the same thickness as the member and in the same general position until two consecutive studs are tested and found to be satisfactory. Two consecutive studs shall then be welded to the member, tested and found to be satisfactory before any more production studs are welded to the member.

For members having less than 20 stud shear connectors, the stud welding procedure may be tested at the start of each day's production welding period in lieu of testing in accordance with the previous paragraph.

A new production period begins with the welding of a given size and type stud with a given welding procedure or with the beginning of each day's production.

Before use in production, each welding unit shall be used to weld two stud shear connectors to separate test material in the same general position (i.e., flat, vertical, overhead, sloping) and of a similar thickness. After being allowed to cool, they shall be bent as described above. If failure occurs, the procedure shall be corrected and two consecutive studs shall be welded to the test material, tested and found to be satisfactory before any production studs are welded to the member.

The foregoing testing shall be performed after any change in the welding procedure.

If failure occurs in the stud shank, an investigation shall be made to ascertain and correct the cause before more studs are welded.

Applications Other Than Shear Connectors. Before starting the welding operations or at the request of the EIC or Inspector, two stud connectors shall be welded to separate material in the same general position (i.e., flat, vertical, overhead, sloping) and of a thickness and material similar to the member. After being allowed to cool, the studs shall be bent to an angle of 30 degrees from their original axes by striking the studs with a two pound hammer. If failure occurs in the weld zone of either stud, the procedure shall be corrected and two more studs shall be welded and tested before any studs are welded to the member. The foregoing testing shall be performed after any change in the welding procedure.

If failure occurs in the stud shank, an investigation shall be made to ascertain and correct the cause before more studs are welded.

On page 159 of AASHTO/AWS D1.5M/D1.5: 2002, Bridge Welding Code, replace Section 7.7.3 as follows:

7.7.3 REPAIR PROCEDURES

Studs on which a full 360 degree flash is not obtained shall be replaced or, at the option of the stud welding contractor, be repaired by adding a $\frac{5}{16}$ inch fillet weld in place of the missing flash. All welding shall be performed using $\frac{5}{32}$ inch diameter E7018 electrodes. All welding procedures and preheat requirements shall be as described in this Manual. The repair weld shall extend at least $\frac{3}{8}$ inch beyond each end of the discontinuity being repaired. The repair weld shall be fused at all boundaries, have full throat throughout its length and all craters shall be filled.

If an unacceptable stud has been removed from a component subjected to tensile stresses, then the area from which the stud was removed shall be made smooth and flush. Where base metal has been pulled out in the course of stud removal, manual shielded metal arc welding with low hydrogen electrodes in accordance with the requirements of this manual shall be used to fill the pockets and the weld surface shall be ground flush.

In compression areas of members, if stud failures are confined to shanks or fusion zones of studs, a new stud may be welded adjacent to each unacceptable area in lieu of repair and replacement of the existing weld area. If metal is torn from the base metal of such areas, the repair provisions shall be the same as for tension areas except that when the depth of discontinuity is less than $\frac{1}{8}$ inch or 7% of the base metal thickness, the discontinuity may be faired by grinding in lieu of filling the unacceptable area with weld metal. Where a replacement stud is to be placed in the unacceptable area, the above repair shall be made prior to welding the replacement stud. Replacement shear connector studs shall be tested by bending to an angle of 15 degrees from their original axes. The areas of components exposed to view in completed structures shall be made smooth and flush where a stud has been removed. If studs are welded, without authorization, to areas of webs and flanges subject to calculated tensile stress, they shall be removed and the removal sites shall be repaired and tested as follows:

- 1) Oxygen cut $\frac{1}{8}$ inch above the base metal surface.
- 2) Grind flush.
- 3) Hardness test to determine that no remaining portion of the weld or base metal is harder than Rockwell hardness C27.
- 4) Stud removal sites in tension areas which require repair welding will be subject to nondestructive testing as determined by the DCES.

On page 160 of AASHTO/AWS D1.5M/D1.5: 2002, Bridge Welding Code, replace Section 7.8 as follows:

7.8 INSPECTION REQUIREMENTS

If visual inspection reveals any stud shear connector that does not show a full 360 degree flash, any stud that has been repaired by welding, or any stud in which the reduction in length due to welding is less than normal, that stud shall be struck with a two pound hammer and bent to an angle of 15 degrees from its original axis. For studs showing less than a 360 degree weld fillet, the direction of bending shall be opposite the missing weld fillet. Studs that crack in the weld, the base metal, or the shank under inspection or subsequent straightening shall be replaced. Non-fusion on the vertical leg of the flash and small-shrink figures are acceptable.*

For studs other than shear connectors, at least one stud in every 100 shall be bent to an angle of 15 degrees from its original axis by striking with a two pound hammer. If threaded, the stud shall be tested with a calibrated torque wrench to the value shown in Figure 7.3 of AWS for the diameter and thread of the stud, in a device similar to that shown. If the stud fails, the procedures shall be checked in accordance with 7.7.1 and two more of the existing studs shall be bent or torque-tested. If either of these two studs fail, all studs represented by the tests shall be torque-texted, bend-tested or rejected. For critical structural connections, the DCES shall designate the type and extent of additional inspection in the Contract.

Non-fusion on the vertical leg of the flash and small-shrink fissures are acceptable.*

The Inspector, where conditions warrant, may select a reasonable number of additional studs to be subjected to the tests specified above.

The bent stud shear connectors and concrete anchors that show no sign of failure shall be acceptable for use and left in the bent position if no portion of the stud is less than 1 inch from a proposed concrete surface. All required bending and straightening shall be done, without heating, before completion of the stud welding operation on the job, except as otherwise provided in the Contract.

If studs welded during the progress of the work are not in accordance with the provisions of this Manual, the Contractor shall make changes (such as welding procedure, welding equipment, and stud base) necessary to ensure that studs subsequently welded meet the requirements of this Manual.

*The expelled metal around the base of the stud is designated as flash in accordance with the definition of flash in AWS A3.0, Terms and Definitions. It is not a fillet weld such as those formed by conventional arc welding. The expelled metal, which is excess to the weld required for strength, is not detrimental, but, on the contrary, is essential to provide a good weld. The containment of this excess molten metal around a welded stud by the ferrule (arc shield) assists in securing sound fusion of the entire cross section of the stud base. The stud weld flash may have non-fusion in its vertical leg and overlap on its horizontal leg, and it may contain occasional small-shrink fissures or discontinuities that usually form at the top of the weld flash with essentially radial or longitudinal orientation, or both, to the axis of the stud. Such non-fusion on the vertical leg of the flash and small-shrink fissures are acceptable. The fillet weld profiles shown in Figure 723 do not apply to the flash of automatically timed stud welds

Notes:

SECTION 7 WELDING

Part D – Welding of Reinforcing Steel

735. GENERAL

Reinforcing steel shall not be subject to any welding unless specifically shown on the plans or approved by the DCES. Welding shall not be permitted where impact properties are a requirement of the design specification. All welding shall be performed in conformance with a welding procedure specification and joint detail approved by the DCES. Tack welding of reinforcing steel outside the approved weld joint and arc strikes are prohibited.

The American Welding Society, Structural Welding Code-Reinforcing Steel, AWS D1.4 may be used as a reference in preparing welding procedure specifications and joint details for approval.

736. BASE METAL

Reinforcing steel shall conform to requirements of the Standard Specification Reinforcing Steel for Concrete Structures. Other base metals shall conform to the requirements of Section 5, Base Metal, or shall be listed in the approved welding procedure specification.

737. WELD PROCESSES

All field welding of reinforcing steel shall be performed using the manual shielded metal arc welding (SMAW) process. Shop welding of reinforcing steel may be performed using the SMAW, flux cored arc welding (FCAW) process or gas metal arc welding (GMAW) processes in conformance with all applicable requirements of this manual.

738. FILLER METAL

When reinforcing steel is to be welded by the manual shielded metal arc process, E7018 electrodes shall be used unless otherwise specified. When matching filler metal strength is required for welding direct butt splices of A615, Grade 60 bars, the DCES may approve the use of E9018 electrodes. When welding is to be performed by the flux cored arc welding process, E7XT-1 or E7XT-5 electrodes shall be used.

739. PERMISSIBLE STRESSES

Base metal stresses shall be as specified in the applicable design specification. The permissible stresses for bevel and V -groove butt splices in tension or compression shall be the same as the corresponding allowable unit stresses for the base metal in the applicable reinforcing steel design specification, provided it does not exceed 20 ksi for E70XX weld metal or 25.6 ksi for E90XX weld metal. Shear stresses shall not exceed 0.3 times the minimum specified ultimate tensile strength for building welds or 0.27 times the minimum specified ultimate tensile strength for bridge welds. When Class E70 electrodes are used, the maximum shear stress for building and bridge welds shall be 21 ksi and 18.9 ksi respectively.

740. EFFECTIVE DESIGN DIMENSIONS

740.1 Direct Butt Splices. The effective weld area shall be the nominal cross sectional area of the bar being spliced. If different size bars are being spliced, the effective weld area shall be the nominal cross sectional area of the smaller of the two bars at the splice.

740.2 Flare-Bevel and Flare-V-Groove Welds. The effective weld area shall be the effective weld length multiplied by the effective weld throat thickness. The effective weld length of flare-bevel and flare- V-groove welds shall be the overall length of the full sized flare-bevel or flare- V-groove weld. No deduction in effective length shall be made for either the start or the crater of the weld if the weld is full size throughout its length.

The minimum effective weld length of a flare-bevel or a flare- V -groove weld shall not be less than two times the bar diameter for equal bars, or two times the smaller bar diameter for two unequal bars.

The effective throat of a flare-bevel or a flare- V -groove weld when filled flush to the solid section of the bar shall be 0.4 and 0.6 respectively of the radius of the bar as shown in Figure 740. Larger effective throats may be used provided the welding procedure for indirect butt splices is qualified by test as approved by the DCES. When bars of unequal diameter are joined, the effective throat shall be based on the radius of the smaller bar.

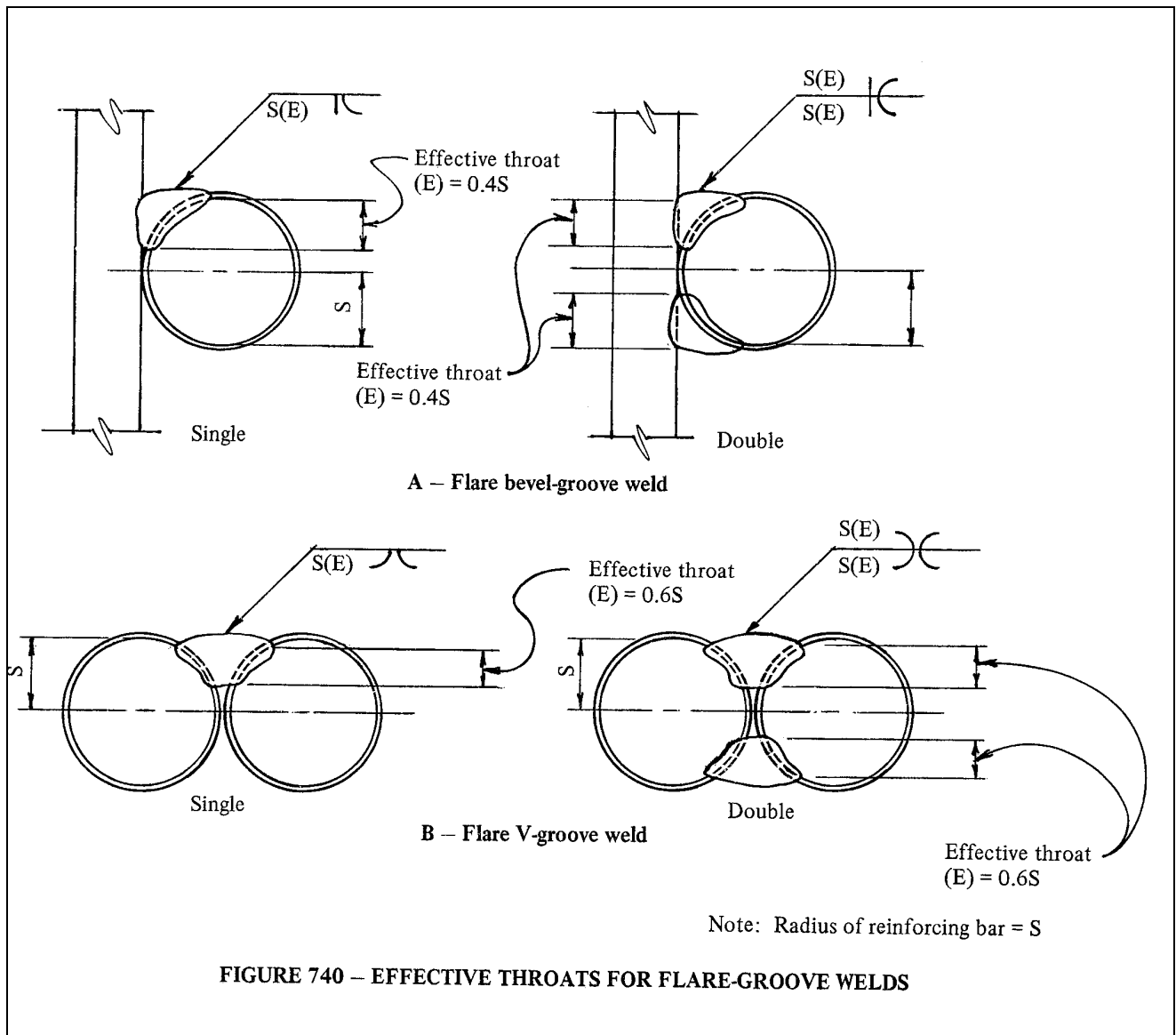

741. JOINT DETAILS

741.1 General. Joints shall be detailed as direct butt splices, indirect butt splices or lap welded splices. Welding symbols shall be as designated in AWS A2.4, Symbols for Welding and Nondestructive Testing. Special conditions shall be fully explained by added notes or details.

741.2 Direct Butt Splice Details. A direct butt splice is defined as a splice between two bars whose axes are approximately collinear with the bars being joined by a complete joint penetration groove weld made from both sides or from one side with backing.

A direct butt splice between two bars whose axes are in an approximately horizontal position shall be made preferably with either single- or double- V-groove welds with each bar beveled to provide a groove angle or angles of between 45° and 60° as shown in Figure 741.2 A and B. A direct butt splice between bars whose axes are in an approximately vertical position shall be made preferably with either single or double bevel groove welds with the end of the lower bar cut approximately 90° to the bar axis

and the upper bar beveled to a groove angle or angles of approximately 45° as shown in Figure 741.2 C and D. Direct butt splices in bars No.8 and smaller using a single-V-groove or single- bevel-groove shall be made with the appropriate backing as shown in Figure 741.2 E and F.

741.3 Indirect Butt Splice Details. An indirect butt splice is defined as a splice between two bars whose axes are approximately collinear, where the bars are welded to a common splice member by either single-or double-flare-bevel or flare-V-groove welds and the cross section of the bars remains unwelded. The splice member may be plate, angle, bar, or other shape as approved by the DCES. The cross sectional area of the splice member shall develop the strength of the bars being spliced. Double-flare-bevel-groove welds shall be used when the splice member is an angle, plate, or flat bar as shown in Figure 741.3 A and B. Double-flare- V -groove welds shall be used when the splice member is a round bar as shown in Figure 741.3 C. Single-flare-bevel and V-groove welds shall be used only when access is limited to one side of the joint.

741.4 Direct Lap Splice Details. A direct lap splice is defined as a splice between two bars whose axes are approximately parallel and approximately in the same plane, where bars in contact are welded together by either single-or double- flare- V-groove welds as shown in Figure 741.4. Double-flare- V -groove welds shall be used for direct lap welded splices unless the joint is accessible only from one side, in which case a single-flare-V-groove weld may be used.

741.5 Indirect Lap Splice Details. An indirect lap splice is defined as a splice between two bars whose axes are approximately parallel and approximately in the same plane, but separated laterally and welded to a common splice plate by single-or-double-flare-bevel-groove welds as shown in Figure 741.5. The cross sectional area of the splice plate shall develop at least the strength of the bars being spliced. The bars shall be substantially in contact with the splice plate as described in Section 744. This splice shall be designed considering the effects of eccentricity and provisions for restraint.

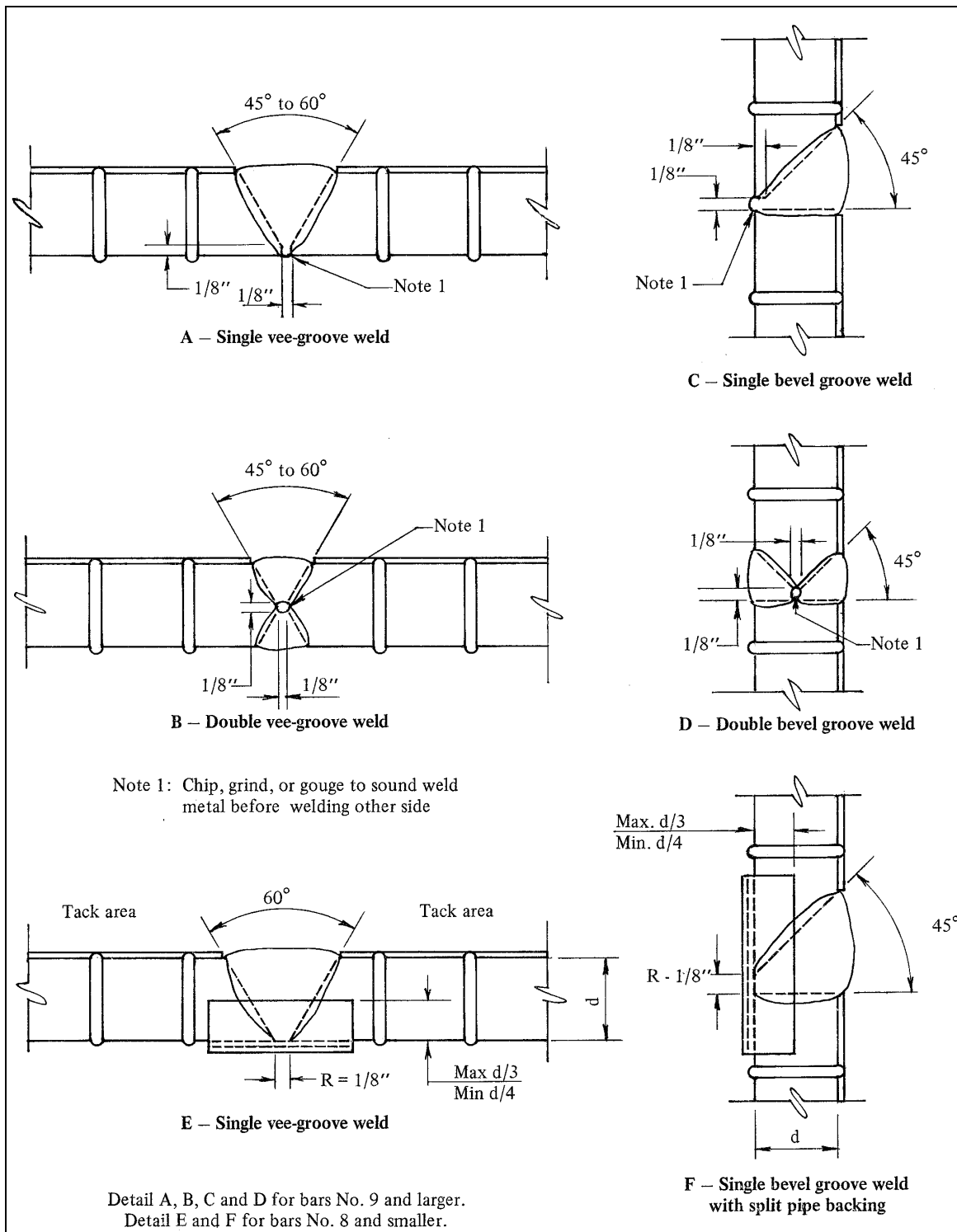
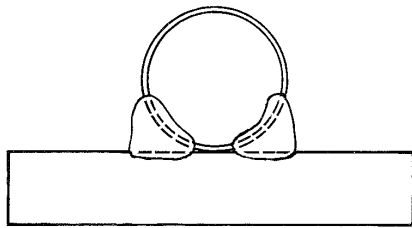
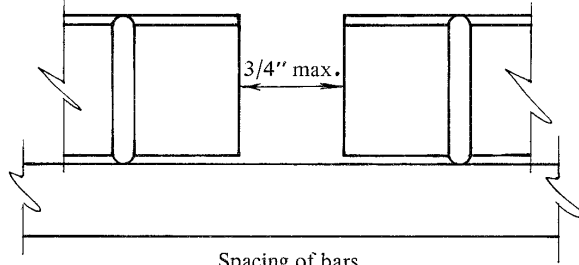

FIGURE 741.2 – DIRECT BUTT SPLICES



Double-flare-bevel-groove weld



Spacing of bars
(similar for detail B)

A – Indirect butt splice using a plate

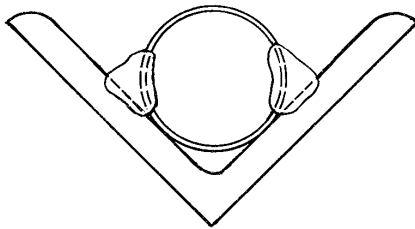

Flare-bevel-groove weld

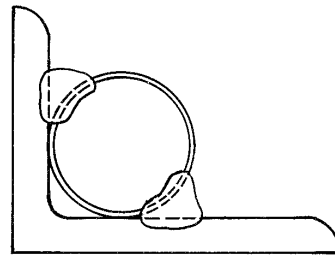

Flare-bevel-groove weld

B – Indirect butt splice using an angle

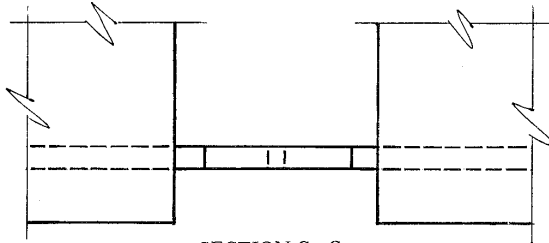

SECTION C - C

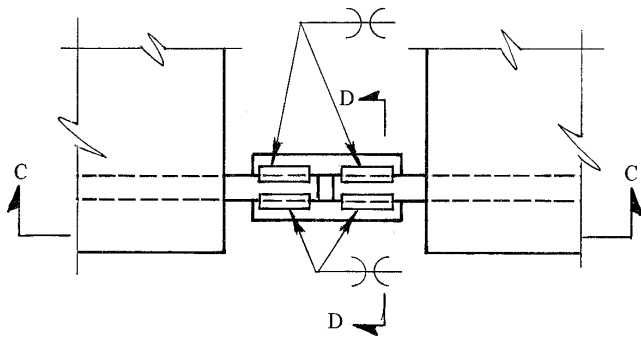

SECTION D - D
Double-flare-V-groove weld

C – Indirect butt splice using two bars

741.3 – INDIRECT BUTT SPLICES

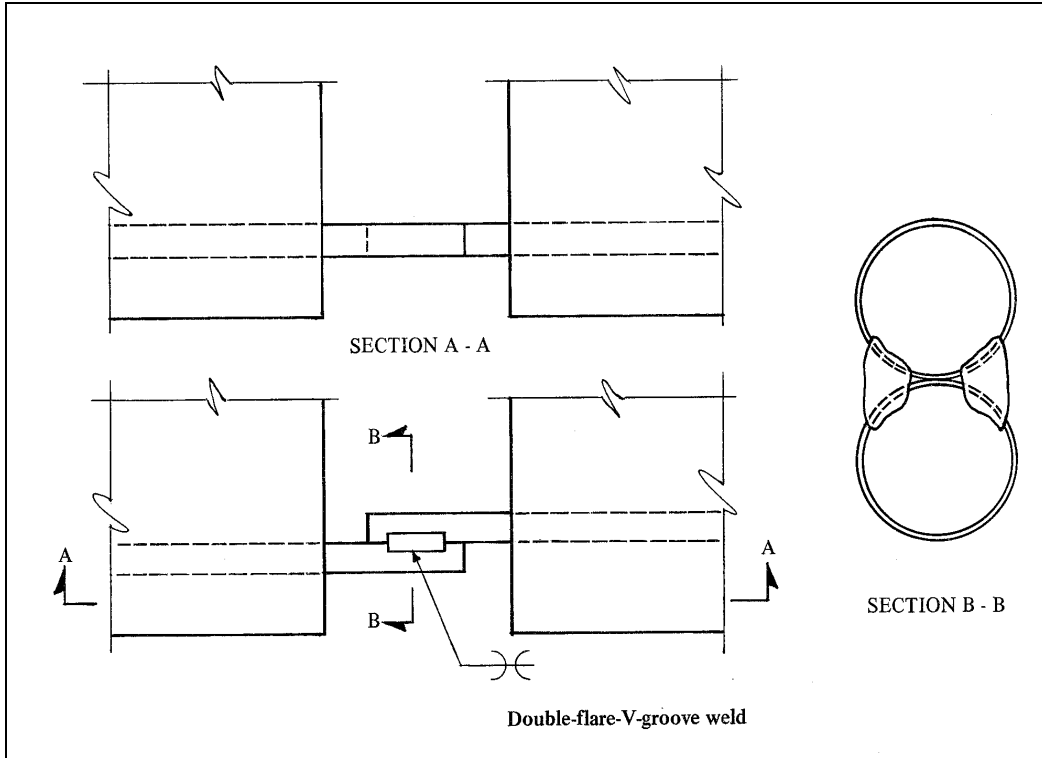

FIGURE 741.4 – DIRECT LAP SPLICE DETAILS

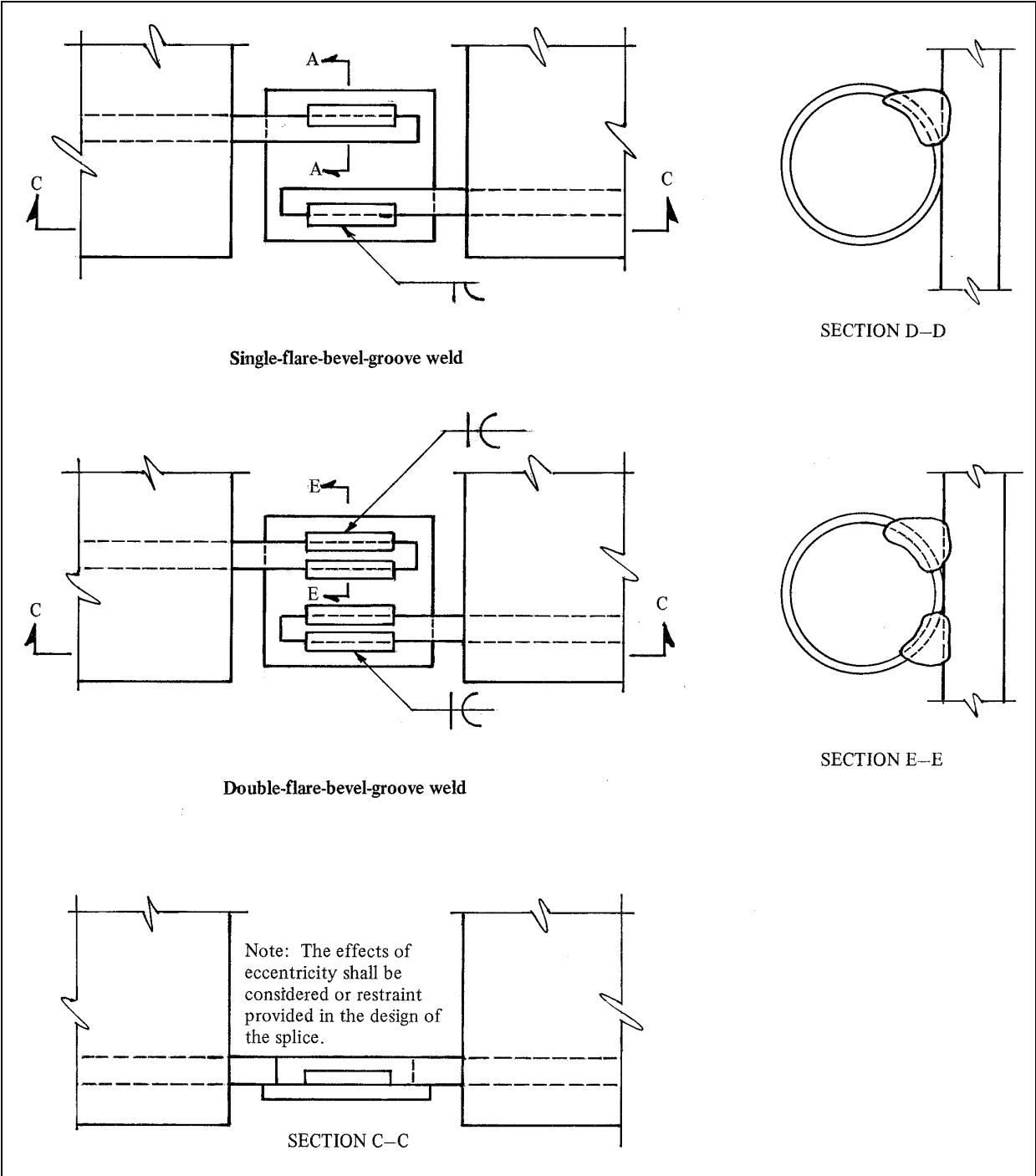

FIGURE 741.5 – INDIRECT LAP SPLICE

742. PREHEAT AND INTERPASS TEMPERATURES

Preheat and interpass temperatures shall be based on the carbon equivalent of the reinforcing steel bars and/or the splice material, whichever number is higher (See Table 742). The carbon equivalent number shall be calculated using the chemical composition as shown on the mill test report which represents the material to be welded. The following carbon equivalent formula shall be used:

$$CE = \%C + \% Mn/6 + \%Cu/40 + \%Ni/20 + \%Cr/10 - \%Mo/50 - \%V/10$$

If mill test reports are not available, chemical analysis may be made on bars representative of the bars to be welded. When the mill test report does not establish the value for Molybdenum (Mo) and Vanadium (V), the carbon equivalent shall be determined by using Carbon (C), Manganese (Mn), Copper (Cu), Nickel (Ni), and Chromium (Cr). If the chemical composition of the bars is not known, or not obtained, the carbon equivalent shall be assumed to be above 0.75 for that material.

TABLE 742 - MINIMUM PREHEAT AND INTERPASS TEMPERATURES

Carbon equivalent range, %	Size of reinforcing bar	Degrees F
0.40 max.	Up to 11 inclusive 14 and 18	50 50
0.41 – 0.45 inclusive	Up to 11 inclusive 14 and 18	50 100
0.46 – 0.55 inclusive	Up to 6 inclusive 7 to 11 inclusive 14 and 18	50 50 200
0.56 – 0.65 inclusive	Up to 6 inclusive 7 to 11 inclusive 14 and 18	100 200 300
0.66 – 0.75	Up to 6 inclusive 7 to 18 inclusive	300 400
above 0.75	Up to 18 inclusive	500

Notes:

- 1) When reinforcing steel is to be welded to main structural material, the preheat requirements of the structural material shall also be considered (see Table 708). The minimum preheat requirement to apply in this situation shall be the higher requirement of the two tables.
- 2) Welding shall not be done when the ambient temperature is lower than 0° F. When the base metal is below the temperature listed for the welding process being used and the size and carbon equivalent range of the bar being welded, it shall be preheated in such a manner that the cross section of the bar for not less than 6 in. on each side of the joint shall be at or above the specified minimum temperature. Preheat and interpass temperatures must be sufficient to prevent crack formation.
- 3) After welding is complete, bars shall be allowed to cool naturally to ambient temperature. Accelerated cooling is prohibited.
- 4) Where it is impractical to obtain chemical analysis, the carbon equivalent shall be assumed to be above 0.75.

743. PREPARATION OF MATERIAL

Surfaces to be welded shall be smooth, uniform, and free from fins, tears, cracks and other defects which would adversely affect the quality or strength of the weld. Surfaces to be welded and surfaces adjacent to a weld shall also be free from loose or thick scale, slag, rust, moisture, grease, paint, epoxy covering, zinc coating, or other foreign material that would prevent proper welding or produce objectionable fumes. Mill scale that withstands vigorous wire brushing, a thin rust inhibitive coating, or antisplatter compound may remain.

The ends of reinforcing bars in direct butt splices shall be trimmed back and shaped to form the welding groove by oxygen cutting, air carbon arc cutting, or by sawing. Roughness of the cut surface shall not be greater than 2000 microinches. Defects in cut surfaces may be repaired as described in Section 601.

744. ASSEMBLY

Joint details shall be arranged to provide the most favorable position for welding. Each joint shall have adequate clearance and accessibility for welding as required by the process being used. The members to be joined shall be aligned to minimize eccentricity.

Bars in direct butt splices shall not be offset at the joint by more than the following:

Bar sizes No.10 or smaller	1/8 inch
Bar sizes No.11 and No.14.....	3/16 inch
Bar size No. 18.....	1/4 inch

For indirect butt splices, the maximum gap between the bar and splice member shall not exceed one quarter of the bar diameter or more than 3/16 inch.

For direct lap splices, the maximum gap between the bars shall not exceed one quarter of the bar diameter or more than 1/4 inch with bar bars remaining in approximately the same plane.

For indirect lap splices, the maximum gap between the bar and the splice plate shall not exceed one quarter of the bar diameter or more than 3/16 inch.

Welding shall not be performed within two bar diameters of any portion of a bar that has been cold bent. Welding of crossing bars shall not be permitted during assembly of reinforcement unless approved by the DCES.

745. QUALITY OF WELDS

Fillet welds shall meet the profile requirements shown in Figure 745A, with no deficiencies as shown in Figure 745B.

Groove welds shall be made with some reinforcement unless otherwise provided. The reinforcement shall not exceed 1/8 inch in height measured from the main body of the bar and shall have gradual transition to the plane of the base metal surface as shown in Figure 745A, with none of the deficiencies shown in Figure 745B.

There shall be complete fusion between weld metal and base metal and between successive passes in the weld. Welds shall have no cracks in either the weld metal or the heat affected zone. All craters shall be filled to the full cross section of the weld. Welds shall be free of overlap. Undercutting deeper than 1/32 inch shall not be allowed regardless of the direction of stress except that at points where welds intersect the raised patterns (deformations), undercutting less than 1/16 inch deep shall be acceptable. The sum of diameters of piping porosity in flare-bevel-groove, flare- V -groove and fillet welds shall not exceed 3/8 inch in any linear

inch of weld and shall not exceed $\frac{9}{16}$ inch in any 6 inch length of weld. Welds that do not meet the quality requirements stated herein shall be repaired in accordance with the provisions of Section 726.

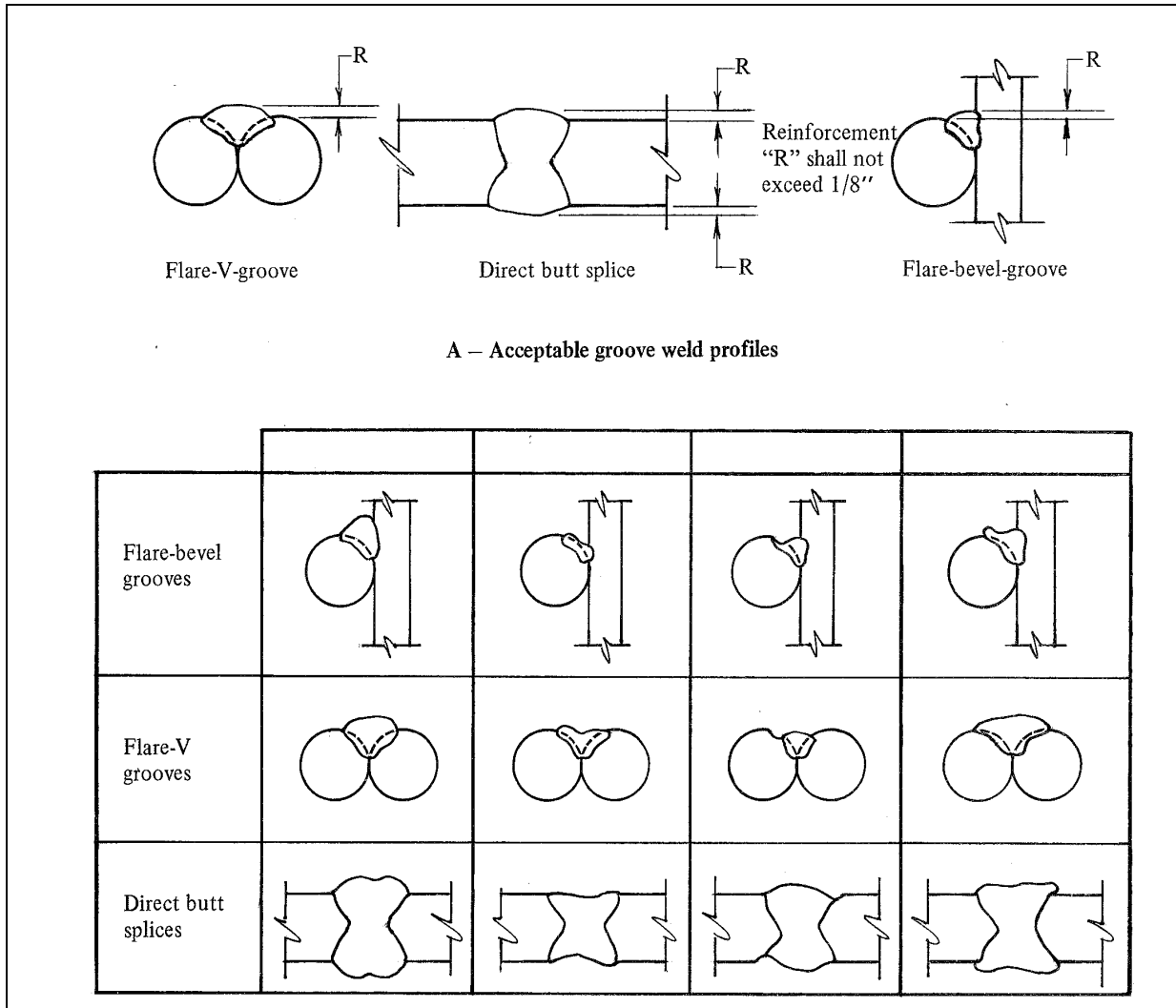

B – Unacceptable groove weld profiles

FIGURE 745 – ACCEPTABLE AND UNACCEPTABLE WELD PROFILES

746. QUALIFICATION

Welders shall be qualified in accordance with Section 8B of this manual. Additional reinforcing steel welding qualification tests may be ordered by the DCES

747. INSPECTION

The provisions of Section 3, Inspection, shall apply. Welds shall be accepted or rejected based upon visual inspection, unless otherwise stated in the Contract Documents. Inspection shall be performed before, during and after welding to insure compliance with this specification.

SECTION 8 QUALIFICATION

Part A – Welding Procedure Qualification

801. GENERAL

Approved welding procedures shall consist of approved joint welding details which are welded using approved Welding Procedure Specifications (WPS). The procedures for manual shielded metal arc welding shall be considered prequalified and exempt from procedure qualification testing when operated within the limits recommended by the electrode manufacturers. Welding shall be performed in accordance with the provisions of Section 7B, Welding. The DCES reserves the right to order a SMAW procedure qualification test when the joint welding procedure(s) or welding consumables, used or to be used, justify such a test. The test(s), if ordered, shall be as directed by the DCES. All other welding procedures shall be qualified by tests described herein.

The Contractor shall submit a proposed welding procedure to the DCES for review and approval. The welding parameters for this procedure shall be shown on a form similar to Figure 801a. This information will be used to determine the Procedure Qualification Record (PQR) test(s) required.

A complete PQR test shall be performed for each electrode, or electrode with shielding media combination on the test plate described in Figure 801b. Additional tests may be required as determined by the DCES.

A modified PQR test may be performed on the test plate described in Figure 801d for SAW, GMAW and FCAW if the proposed procedure includes an electrode, or electrode with shielding media combination which is on record with the DCES and has produced satisfactory test results using welding parameters within the limitation of variables described in Section 805.

When joint welding details to be used in the work are not prequalified under the provisions of Section 703, the joint details and welding procedure shall be subject to complete qualification testing using a test plate conforming to Figure 801b, but modified to duplicate the weld joint details and thickness. The number of weld passes and operating variables shall be identical to those to be used in the work. Approval of unusual details and unusual procedures for operating SMAW, SAW, FCAW or GMAW may be denied on the basis of concern for increased weld defects or diminished weld properties. Approval of such procedures may require nondestructive tests of production welds at the Contractor's expense. Tee and corner weld details and procedures shall be tested as butt welds as determined by the DCES. When the qualification test plate thickness is less than one inch to duplicate a production weld, the DCES may modify or delete specific test specimens.

The DCES may order modification of any of the above tests as necessary to establish the acceptability of the welding procedure specification.

Any deviation from the approved welding procedure, beyond the limits described in Section 805, Limitations of Variables, shall be cause for rejection unless approved by the DCES.

Any variation from the approved WPS, beyond the limits described in Section 805, Limitation of Variables, shall be cause for rejection.

All approved PQR's shall be subject to verification testing at intervals not exceeding five years. The modified procedure qualification test shall be used for requalification of SAW, GMAW and FCAW processes unless otherwise specified. The DCES may order additional qualification testing whenever there appear to be deficiencies in production welding.

Unless otherwise specified, fillet welding procedures shall be qualified by testing in a groove weld configuration as described in Figures 801b or 801d. These tests shall be performed using the fillet welding parameters (amps, volts, travel speed, etc.) listed in the fillet welding procedure specification. Care should be taken in all weld testing to avoid unnecessary build-up of interpass temperature which is not representative of actual conditions in the work. Unnecessary temperature build-up may adversely affect notch toughness test results.

**NEW YORK STATE
DEPARTMENT OF TRANSPORTATION ~
WELDING PROCEDURE QUALIFICATION RECORD**

Fabricator _____ Test Date _____

Process _____ Filler Metal Classification _____

Electrode(s) _____ Flux _____

(1) Diameter _____ Amps _____ Volts _____ Current & Polarity _____

(2) _____

(3) _____

Shielding Gas _____ Flow Rate _____ Dew Point _____

Travel Speed _____ Material Specification & Thickness _____

Preheat Temp. _____ Interpass Temp. _____

Heat Input _____ FCM G Yes G No

SPECIMEN	TEST RESULTS	
All Weld Metal Tension (AWMT)	(1)	(2)
	Tensile Strength (psi) _____	_____
	Yield Strength (psi) _____	_____
	Elongation in 2" (%) _____	_____
	Reduction in Area (%) _____	_____
Side Bends	1. _____ 2. _____ 3. _____ 4. _____	
Reduction Section Tension	Tensile Strength 1. _____ 2. _____	Location of Break 1. _____ 2. _____
Charpy Impact (Weld Metal)	(_____, _____, _____, _____, _____)	
	Avg. Ft. Lbs. ____ @ ____ °F	
	(_____, _____, _____, _____, _____)	
	Avg. Ft. Lbs. ____ @ ____ °F	
	ESW & EGW (_____, _____, _____, _____, _____, _____, _____, _____)	
	Avg. Ft. Lbs. ____ @ ____ °F	
Chemistry	C. _____ Mn. _____ P. _____ S. _____ Si. _____	
	Ni. _____ Cr. _____ Mo. _____ V. _____ Cu. _____	

REMARKS:

Test Witness: _____ Agency _____

Results Reviewed: _____ DOT Acceptance _____ Date _____

FIGURE 801a – SAMPLE WELDING PROCEDURE QUALIFICATION RECORD

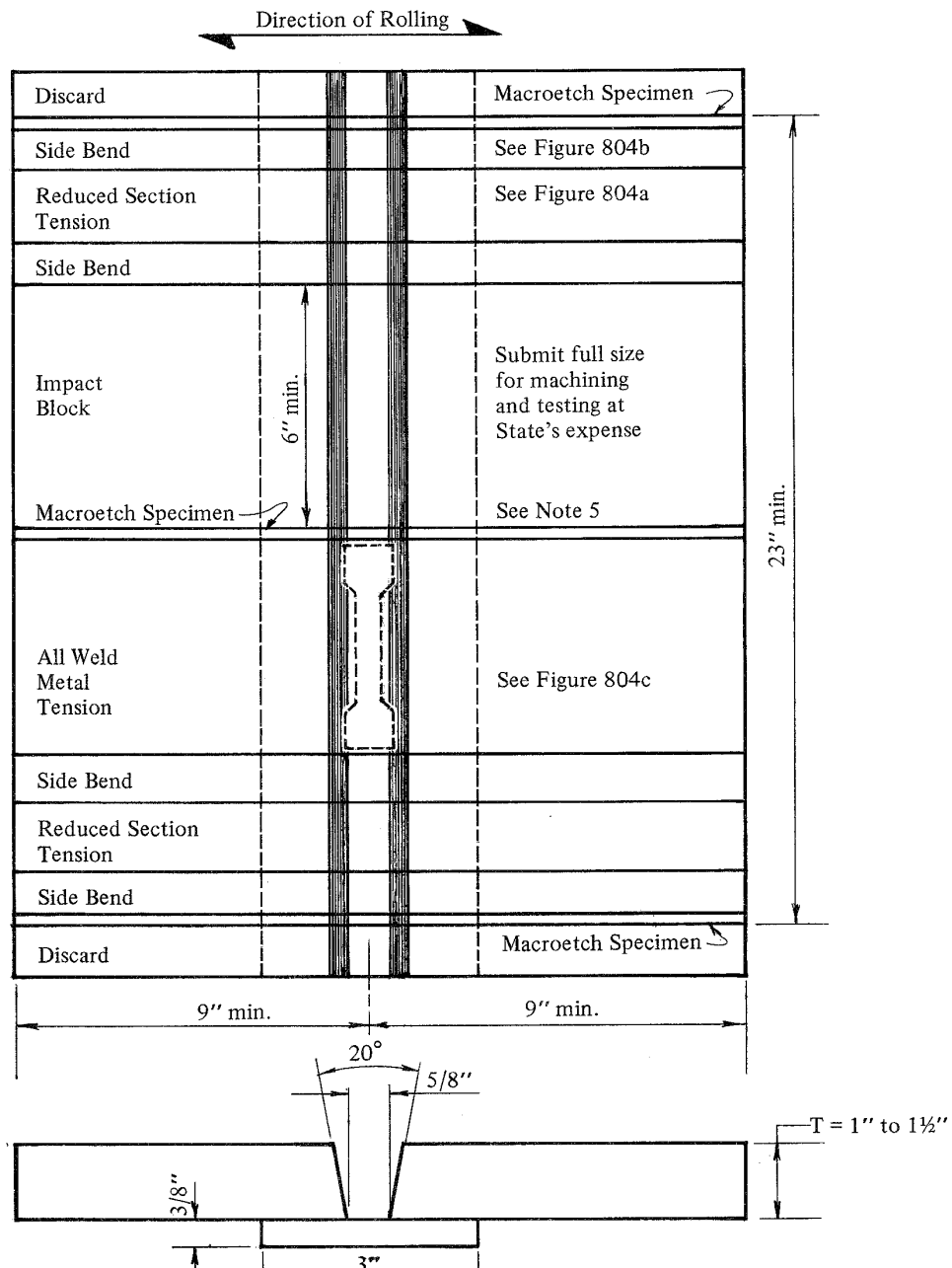

NOTES:

1. The type of steel used in this test shall be approved by the DCES.
2. Minimum preheat shall be in accordance with Table 708.
3. Welding shall be witnessed by a State representative.
4. Test specimens and the Welding Procedure Qualification Record showing all welding parameters used for the test shall be submitted to the DCES for testing and review.
5. When required, macroetch specimens 3/8" thick and "T" wide shall be removed for testing. At least one cut face of each specimen shall be polished and etched for macroscopic examination by the DCES.

FIGURE 801b – COMPLETE PQR TEST PLATE FOR SAW, GMAW & FCAW

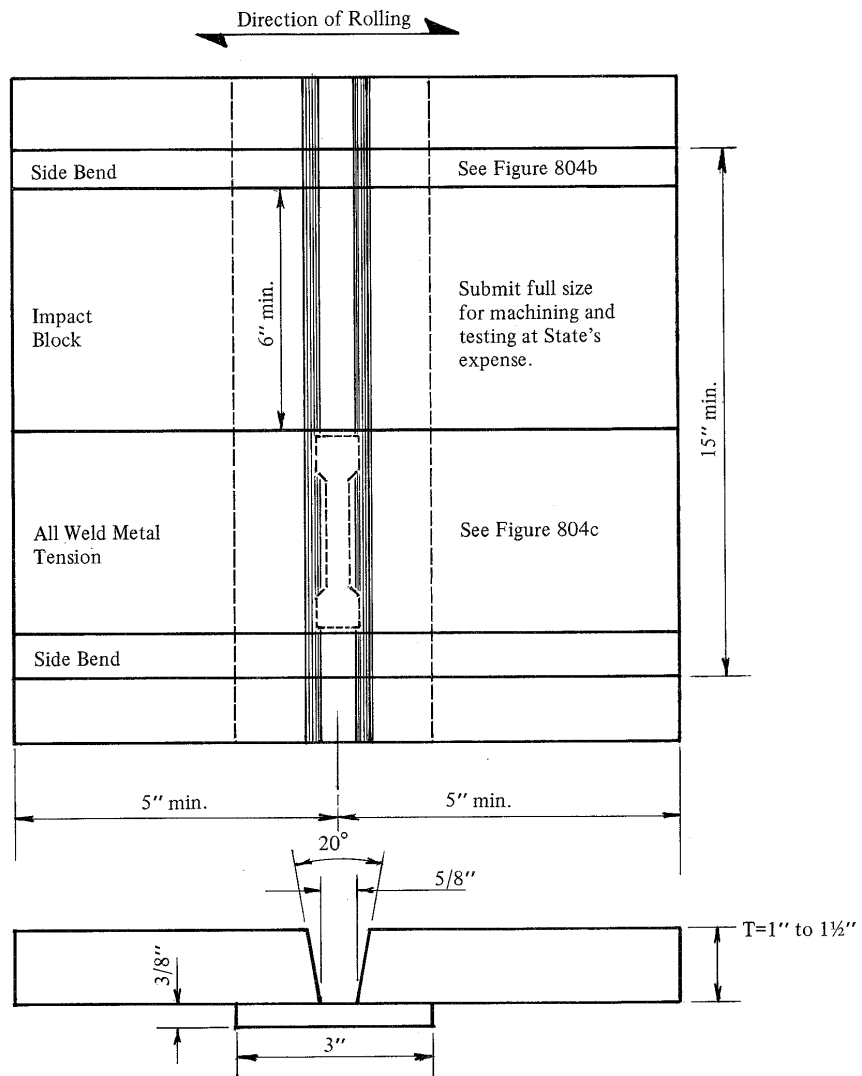

NOTES:

1. The type of steel used in this test shall be approved by the DCES.
2. Minimum preheat shall be in accordance with Table 708.
3. Welding and machining shall be witnessed by a State representative.
4. Test specimens and the Welding Procedure Qualification Record showing all welding parameters used for the test shall be submitted to the DCES for testing and review.

FIGURE 80ld – MODIFIED PQR TEST PLATE FOR SAW GMAW AND FCAW

802. BASE METAL AND ITS PREPARATION

The base metal and its preparation for welding shall comply with the approved WPS. For all types of welded joints the length of the weld and the dimensions of the base metal shall be in accordance with Figures 801b and 801d.

Qualification of a PQR established with a base metal listed in Section 5, Base Metals, having a minimum specified yield point of 70 ksi or less, shall qualify the procedure for welding any other base metal or combination of base metals listed in Section 5 which have a minimum specified yield point equal to or less than that of the base metal used in the test.

803. TEST POSITIONS

Submerged arc (SAW) and Gas Metal Arc (GMAW) welding tests shall be performed in the flat position using the test plates shown in Figures 801b or 801d, as determined by the DCES.

Flux cored arc (FCAW) welding tests shall be performed in the position to be used in the work as defined in Figure 810. Tests for the flat, vertical, and overhead positions shall be welded using the test plates shown in Figures 801b or 801d, as determined by the DCES. The test for the horizontal position shall be welded using a plate similar to Figure 801b or 801d, except the joint configuration shall be B-U4a-GF.

804. TEST SPECIMENS

The types of specimens outlined below are used to determine the mechanical properties, degree of soundness and chemical composition of welded joints made with specific weld procedure specifications.

- a) Reduced Section Tension Specimens to determine tensile strength (See Figure 804a).
- b) Side Bend Specimens to determine soundness (See Figure 804b).
- c) All Weld Metal Tension Specimen to determine mechanical properties (See Figure 804c).
- d) Charpy V-Notch Impact Specimens to determine toughness (See ASTM A370).
- e) Chemical Analysis to determine weathering properties (See ASTM A751).
- f) Radiographic Test to determine soundness. All PQR test plates shall be subject to radiographic testing as described in Section 16. Machining of test specimens shall not begin until radiographic tests has been submitted and approved by the DCES.
- g) Fillet Weld Macroetch Test to determine weld fusion, weld bead size, and layer depth. A fillet weld tee test as shown in Figure 804d shall be made when ordered by the DCES. The maximum size single pass fillet weld and the minimum size multiple pass fillet weld used in construction shall be tested. These two fillet weld tests may be combined in a single test plate. The test plate shall be cut perpendicular to the direction of welding at three locations. Specimens representing one face of each of the three cuts shall be polished and etched to clearly define the weld metal and heat affected zones. A clear protective coating shall be applied to prevent corrosion. The specimens shall be submitted to the DCES for examination.
- h) Groove Weld Macroetch Tests to determine weld fusion, weld bead size, layer depth and effective throat. When required by the DCES, the test weld(s) shall be cut perpendicular to the direction of welding and the cut surfaces shall be polished and etched to clearly define the weld metal and heat affected zones. A clear protective coating shall be applied to prevent corrosion. The specimens shall be submitted to the DCES for examination.

The impact block shall be full thickness with the weld reinforcement ground flush and shall measure 6 inches by 6 inches minimum.

When weathering steel is to be used, the chemistry of the weld metal shall be determined by chemical analysis of portions of Charpy V-Notch or all weld metal tension specimens after they have been mechanically tested.

The Contractor shall send the test plate to an Independent Testing Laboratory, and have that Laboratory perform the required testing at the Contractor's expense.

The Independent Laboratory must be currently accredited as a Material Testing Laboratory by one of the following:

1. AASHTO Accreditation Program (AAP)
2. Construction Materials Engineering Council's (CMEC's) ISO 17025 accreditation program
3. Laboratory Accreditation Bureau, L-A-B
4. National Cooperation for Laboratory Accreditation (NACLA)

The Contractor shall submit the name of the Testing Laboratory along with a copy of the applicable accreditation certification to the DCES, 15 work days prior to testing. The State may elect to send a NYSDOT representative to witness the testing.

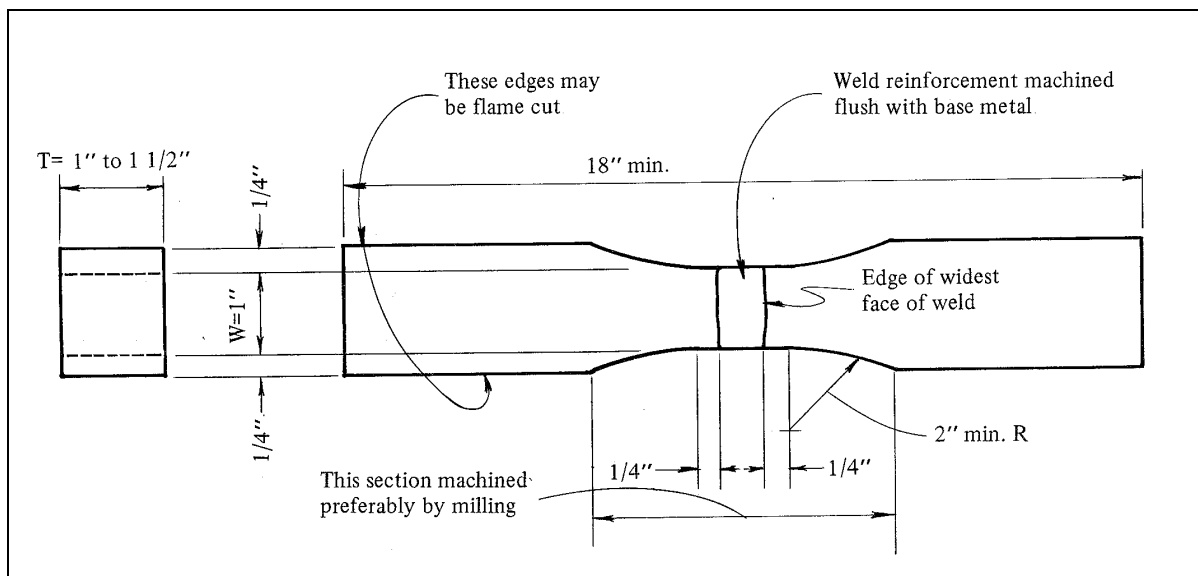

FIGURE 804a
REDUCED SECTION TENSION SPECIMEN

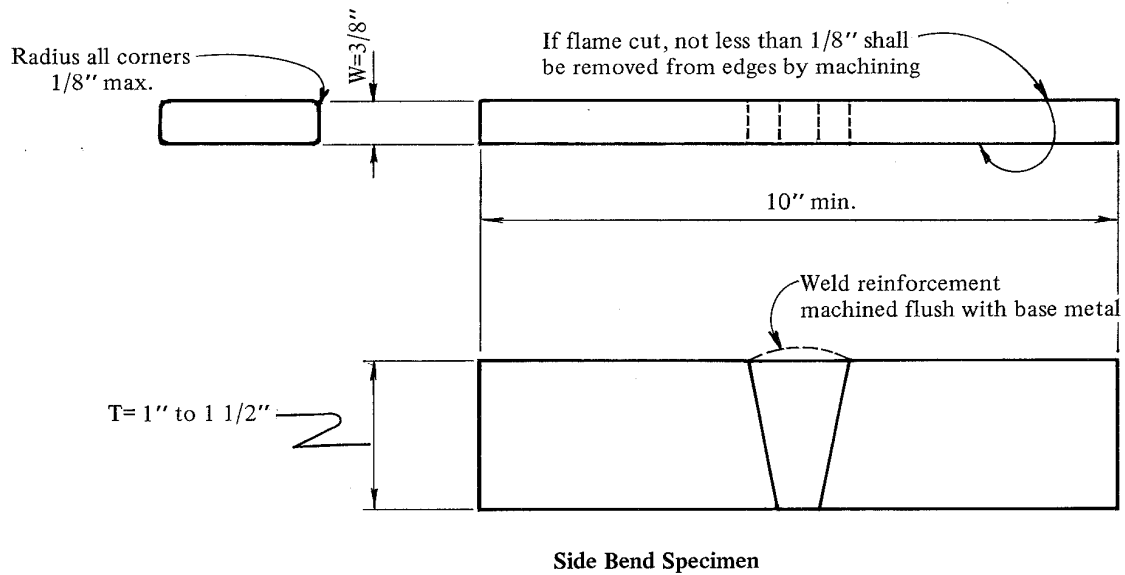
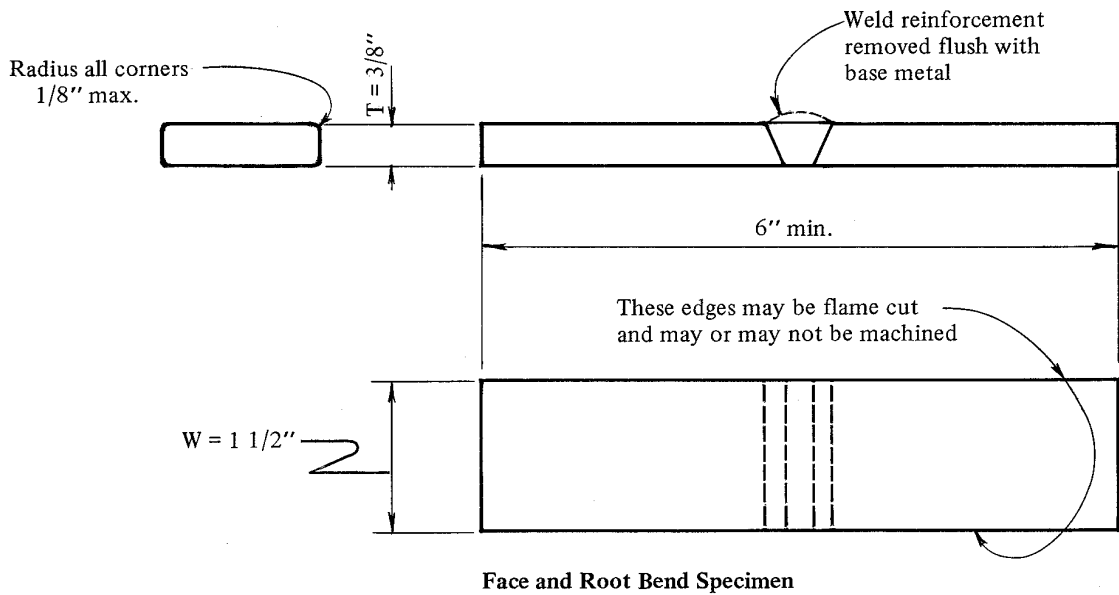
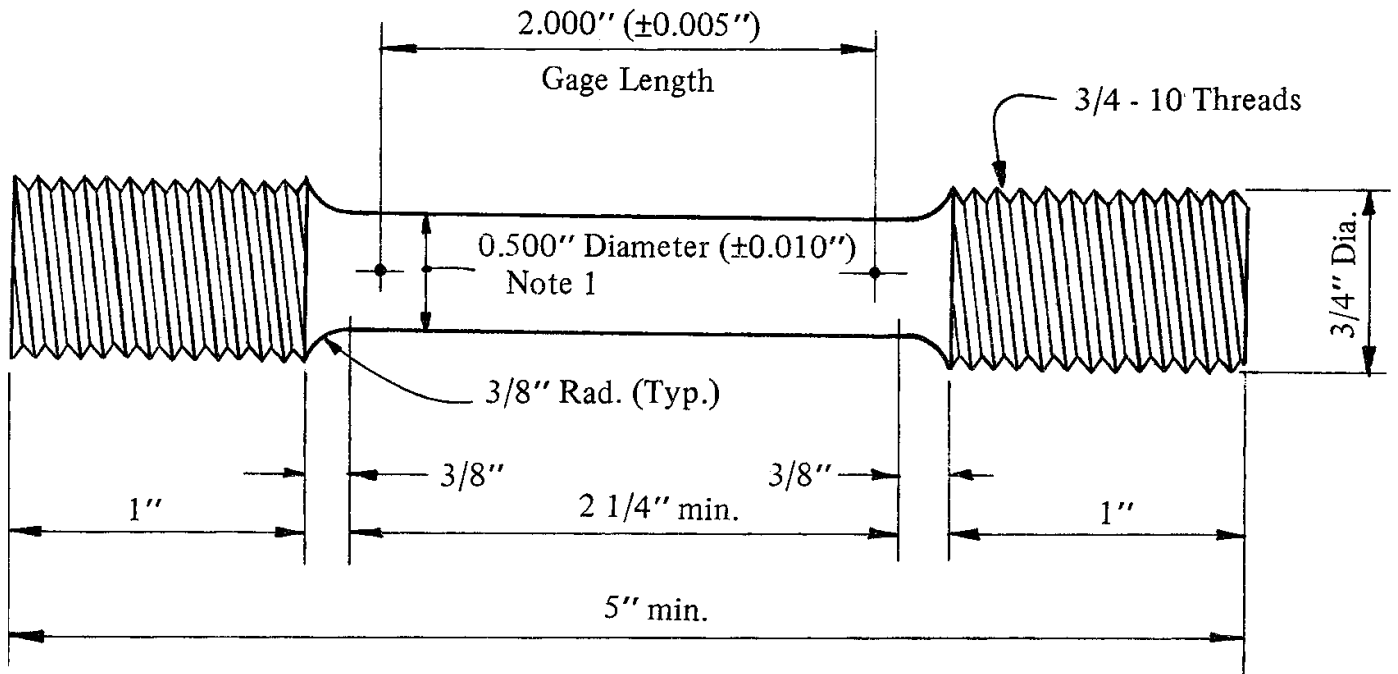

FIGURE 804b – BEND SPECIMENS



NOTES.

NOTES:

1. The reduced section may have a gradual taper from the ends toward the center with the ends not more than 0.005 inch larger in diameter than the center.
2. Specimen taken from the center of a weld.

FIGURE 804c - STANDARD ROUND ALL WELD METAL TENSION SPECIMEN

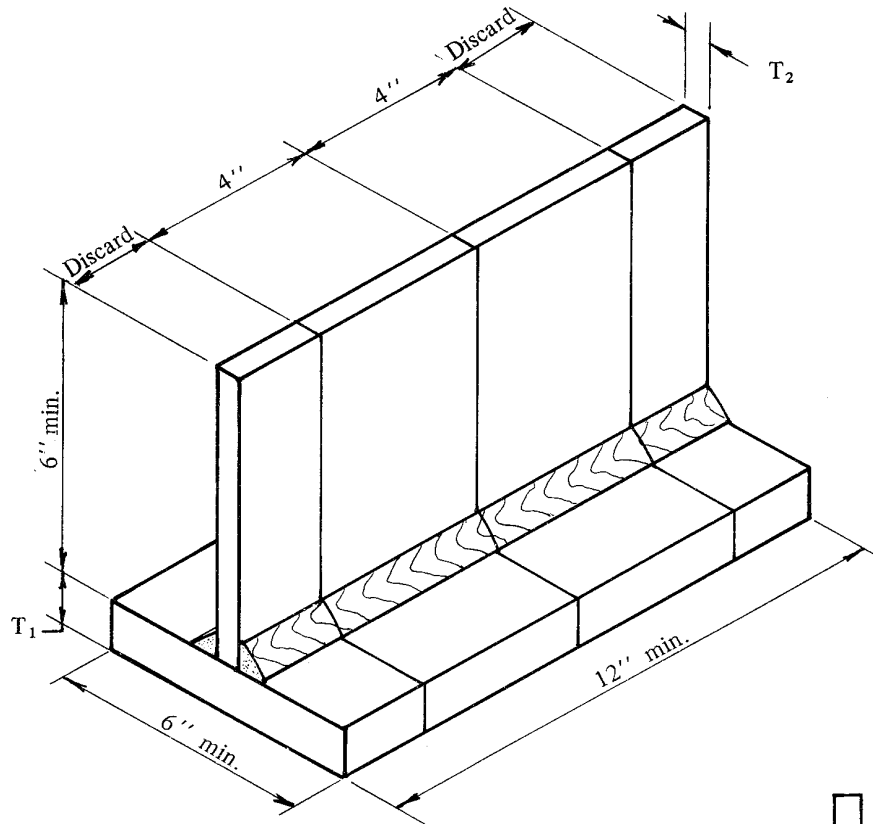

Weld size	T ₁ min.	T ₂ min.
3/16	1/2	3/16
1/4	3/4	1/4
5/16	1	5/16
3/8	1	3/8
1/2	1	1/2
5/8	1	5/8
3/4	1	3/4
> 3/4	1	1

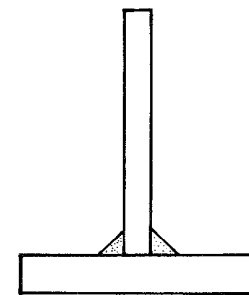

Macroetch Test Specimen

Notes:

1. Where the maximum plate thickness used in production is less than the value shown in the table, the maximum thickness of the production pieces may be substituted for T₁ and T₂.
2. At the contractor's option, the maximum single pass fillet welds may be welded on one side of the joint, and the minimum multiple pass fillet weld may be welded on the other side.

FIGURE 804d – FILLET WELD SOUNDNESS TEST FOR PROCEDURE QUALIFICATION

805. LIMITATION OF VARIABLES

The variables described below shall be considered essential changes in a welding procedure and shall require establishing a new procedure specification. The Complete Procedure Qualification Test shall be performed unless a Modified Procedure Qualification Test is approved under the provisions of Section 801.

When a combination of welding processes is used, the variables applicable to each process shall apply.

805.1 Submerged Arc Welding.

- a) A change in electrode or flux.
- b) A change increasing filler metal strength or toughness classification.
- c) A change in electrode diameter when using an alloy flux.
- d) A change in the number of electrodes used.
- e) A change in the type of current (ac or dc) or polarity.
- f) A change of more than 10% above or below the specified amperage for each electrode diameter used.
- g) A change of more than 7 % above or below the specified arc voltage for each diameter electrode used.
- h) A change of more than 15 % above or below the specified travel speed.
- i) A change of more than 10 %, or $\frac{1}{8}$ inch, whichever is greater, in the longitudinal spacing of the arcs.
- j) A change of more than 10 %, or $\frac{1}{16}$ inch, whichever is greater, in the lateral spacing of the arcs.
- k) A change of more than ± 10 degrees in the angular position of any parallel electrode.
- l) A change in the angle of electrodes in machine or automatic welding of more than
 - 1) ± 3 degrees in the direction of travel.
 - 2) ± 5 degrees normal to the direction of travel.
- m) For a specified groove, a change of more than ± 25 % in the specified number of passes. If the area of the groove is changed, it is permissible to change the number of passes in proportion to the area.
- n) A change in the type of joint.
- o) An increase in the diameter of the electrode used over that called for in the procedure specification.

805.2 Flux Cored and Gas Metal Arc Welding.

- a) A change in electrode or method of shielding.
- b) A change increasing filler metal strength level, when permitted, but not vice versa.
- c) An increase in the diameter of electrode.
- d) A change in the number of electrodes used.
- e) A change from a single gas to any other single gas or to a mixture of gases or a change in specified percentage composition of gas mixture, when permitted.
- f) A change of more than 10 % above or below the specified amperage for each size electrode used.
- g) A change of more than 7 % above or below the specified arc voltage for each size electrode used.
- h) A change of more than 10 % above or below the specified travel speed.
- i) An increase of 25 % or more or a decrease of 10 % or more in the rate of flow of shielding gas or mixture.
- j) For a specified groove, a change of more than ± 25 % in the specified number of passes. If the area of the groove is changed, it is permissible to change the number of passes in proportion to the area.
- k) A change in the position in which welding is performed as defined in Section 809.5a.
- l) A change in the type of joint.
- m) A change in type of welding current (ac or dc), polarity, or mode of metal transfer across the arc.

806. METHOD OF TESTING SPECIMENS

Specimens shall be tested in accordance with the following specifications:

- a) Reduced Section Tension SpecimenASTM A370
- b) Side Bend SpecimensASTM E190, E290
- c) All Weld Metal Tension SpecimenASTM A370
- d) Charpy V-Notch Impact SpecimenASTM A370
- e) Chemical Analysis.....ASTM A751
- f) Radiographic Test.....SCM Section 16
- g) Ultrasonic TestSCM Section 17
- h) Macroetch SpecimenASTM E340

807. TEST RESULTS

807.1 Reduced Section Tension Tests. The tensile strength shall not be less than the minimum specified tensile strength of the base metal.

807.2 Side Bend Tests. Side bend specimens shall be placed with the side showing the greater discontinuity, if any, directed toward the gap. The convex surface of the specimen shall be examined for the appearance of cracks or other open discontinuities. The specimen shall not have a crack or other open discontinuity exceeding 1/8 inch, measured in any direction. Cracks at the corners of the specimen shall not be considered except when they are longer than 1/4 inch, in which case the DCES may order additional bend tests and may determine that excessive cracking is cause for rejection of the specimen.

807.3 All Weld Metal Tension Test. Mechanical properties shall meet the requirements of AWS D1.5 for the electrode or electrode flux classification specified.

807.4 Charpy V-Notch Impact Test. Five specimens shall be tested to determine the minimum Charpy V-Notch Impact Value. The extreme lowest and highest value obtained with the five specimens shall be discarded and the average value for the remaining three specimens shall be as specified in AWS D1.5. If the energy value for more than one of the remaining three specimens is below the minimum average requirement, or if the energy value for one of the three specimens is less than two-thirds (2/3) of the specified minimum average requirement, a retest shall be made, and the energy value of all three retest specimens, after discarding the highest and lowest values, shall equal or exceed the specified minimum average requirement.

807.5 Chemical Analysis. Chemical analysis of filler metal used in weathering applications shall verify that the deposited weld meets the chemical requirements of any one of the electrode or electrode flux classifications shown in AWS D1.5.

807.6 Radiographic Test. The radiograph shall be evaluated in accordance with Section 1605.

807.7 Macroetch Specimen. The macroetch specimen shall meet the dimensional and quality requirements of Section 7, Welding.

808. RETESTS

808.1 General. If any specimen other than an impact specimen fails to meet the test requirements, two retests for that particular specimen may be performed provided the specimens are cut from the same procedure qualification plate. The results of both retests must meet the test requirements.

808.2 Impact Specimens. If the energy value for more than one of the three specimens is below the minimum average requirement or if the energy value for one of the three specimens is less than two-thirds of the specified minimum average requirement, a retest shall be made and the energy value

obtained from each of the three retest specimens shall equal or exceed the specified minimum average value.

808.3 Test Plates. If sufficient material is not available from the original qualification test weldment, a new test plate may be welded provided the parameters used in the retest are the same as those used to weld the original test plate. Any deviation from the original parameters other than those allowed under Section 805, Limitation of Variables, shall be cause to consider the new test plate as a separate qualification test.

SECTION 8 QUALIFICATION

Part B Welder, Welding Operator, and Tacker Qualification

809. GENERAL

Each welder, welding operator, and tacker who performs work on Contracts for the State must be qualified for each process and position used by tests described in this Section. The following job descriptions shall be used to determine the type of tests required:

- a) Welder - A person who performs a manual or semiautomatic welding operation.
- b) Welding Operator - A person who operates adaptive control, automatic, mechanized or robotic welding equipment.
- c) Tacker - A fitter, or someone under the direction of a fitter, who tack welds parts of a weldment to hold them in proper alignment until the final welds are made. Tackers shall be limited to performing work in the fabrication shop.

All qualification tests shall be witnessed by a State representative. At the completion of welding, the State representative shall die stamp the test plate number and identify the witnessing agency, i.e., D.O.T. Region No., or testing agency under contract to the State.

The base metal used for the test plates shall be structural steel of any weldable type that is internally sound and in good condition.

Qualification established by these procedures shall be considered as qualification to weld or tack weld any steel listed in Section 5, Base Metal.

A welder or welding operator who performs a successful procedure qualification test as described in Section 8A shall be considered qualified for that process and position.

A welder, welding operator, or tacker qualified with an approved electrode and shielding medium combination shall be considered qualified to weld or tack weld with any other approved electrode and shielding medium combination for the process used in the qualification test.

810. TEST POSITIONS

All welds shall be classified as being flat, horizontal, vertical, or overhead as described in Figure 810a with the exception of tubular welds which shall be done in accordance with AWS D1.1. Based on this classification, the test plates shall be positioned as described herein.

810.1 Groove Welds. Groove weld qualification test plates shall be oriented in one of the positions described below and in Figure 810b.

- a) Flat Position (1G). The test plates shall be placed in an approximately horizontal plane and the weld metal deposited from the upper side.
- b) Horizontal Position (2G). The test plates shall be placed in an approximately vertical plane with the welding groove approximately horizontal.
- c) Vertical Position (3G). The test plates shall be placed in an approximately vertical plane with the welding groove approximately vertical.

- d) Overhead Position (4G). The test plates shall be placed in an approximately horizontal plane and the weld metal deposited from the under side.

810.2 Fillet Welds. Fillet weld qualification test plates shall be oriented in one of the positions described below and in Figure 810c.

- a) Flat Position (1F). The test plates shall be placed so that each fillet weld is deposited with its longitudinal axis approximately horizontal and its throat approximately vertical.
- b) Horizontal Position (2F). The test plates shall be placed so that each fillet weld is deposited on the upper side of the horizontal surface and against the vertical surface.
- c) Vertical Position (3F). The test plates shall be placed in an approximately vertical plane with the welding preparation approximately vertical.
- d) Overhead position (4F). The test plates shall be placed in an approximately horizontal plane so that each fillet weld is deposited on the under side of the horizontal surface and against the vertical surface.

Tabulation of positions of groove welds			
Position	Diagram reference	Inclination of axis	Rotation of face
Flat	A	0° to 15°	150° to 210°
Horizontal	B	0° to 15°	80° to 150° 210° to 280°
Overhead	C	0° to 80°	0° to 80° 280° to 360°
Vertical	D E	15° to 80° 80° to 90°	80° to 280° 0° to 360°

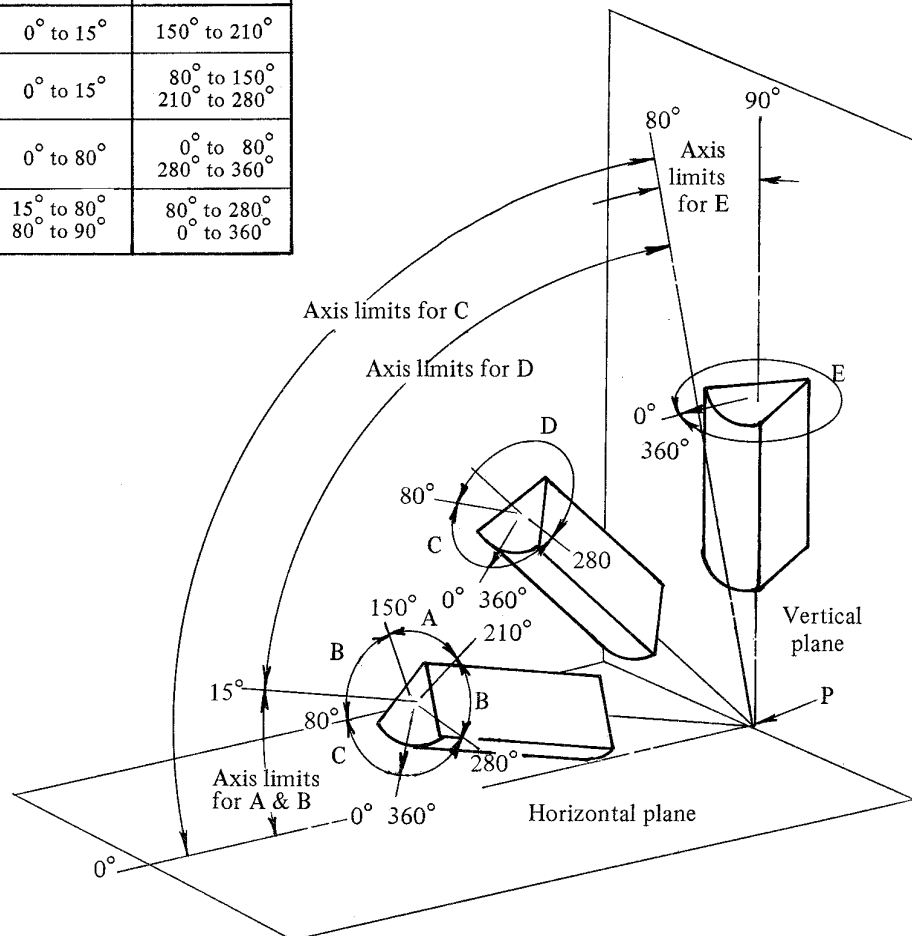

Notes:

1. The horizontal reference plane is always taken to lie below the weld under consideration.
2. The inclination of axis is measured from the horizontal reference plane toward the vertical reference plane.
3. The angle of rotation of the face is determined by a line perpendicular to the theoretical face of the weld which passes through the axis of the weld. The reference position (0°) of rotation of the face invariably points in the direction opposite to that in which the axis angle increases. When looking at point P, the angle of rotation of the face of the weld is measured in a clockwise direction from the reference position (0°).

FIGURE 810a – POSITIONS OF GROOVE WELDS

Tabulation of positions of fillet welds			
Position	Diagram reference	Inclination of axis	Rotation of face
Flat	A	0° to 15°	150° to 210°
Horizontal	B	0° to 15°	125° to 150° 210° to 235°
Overhead	C	0° to 80°	0° to 125° 235° to 360°
Vertical	D	15° to 80°	125° to 235°
	E	80° to 90°	0° to 360°

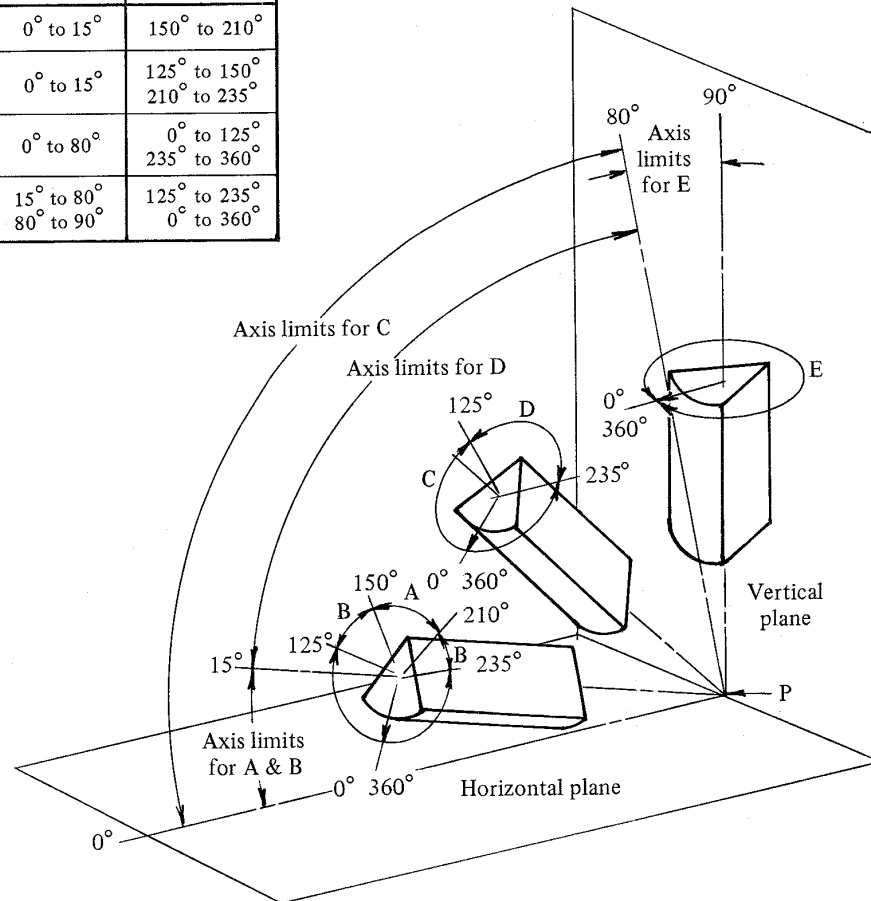

Notes:

1. The horizontal reference plane is always taken to lie below the weld under consideration.
2. The inclination of axis is measured from the horizontal reference plane toward the vertical reference plane.
3. The angle of rotation of the face is determined by a line perpendicular to the theoretical face of the weld which passes through the axis of the weld. The reference position (0°) of rotation of the face invariably points in the direction opposite to that in which the axis angle increases. When looking at point P, the angle of rotation of the face of the weld is measured in a clockwise direction from the reference position (0°).

FIGURE 810a (continued) - POSITIONS OF FILLET WELDS

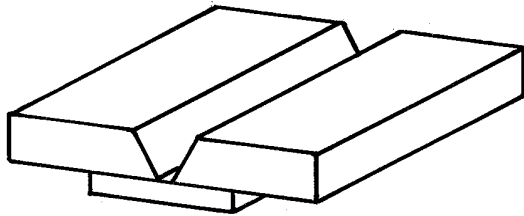

Flat Position (1G)

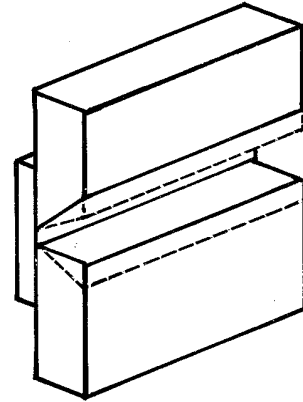

Horizontal Position (2G)

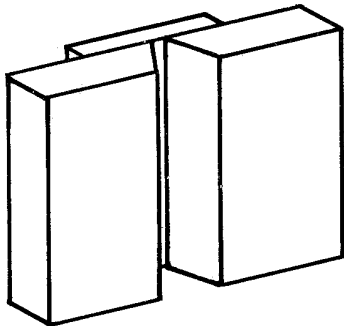

Vertical Position (3G)

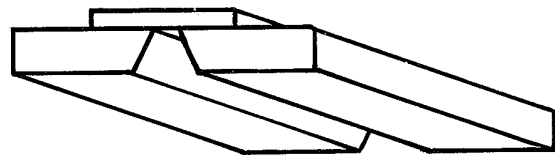

Overhead Position (4G)

NOTE: Test plates must remain in position until welding is complete. All welding shall be in the testing position.

FIGURE 810b – POSITIONS OF TEST PLATES FOR GROOVE WELDS

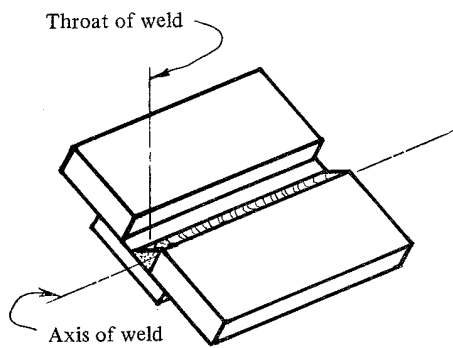

Flat Position (1F)
Axis of weld

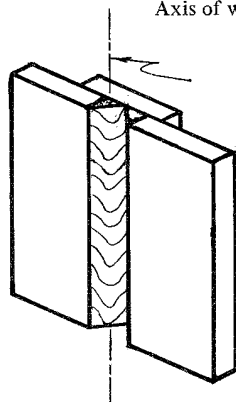

Vertical Position (3F)

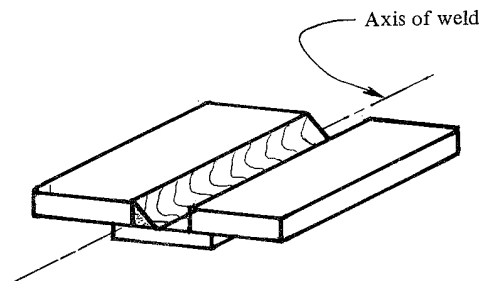

Horizontal Position (2F)

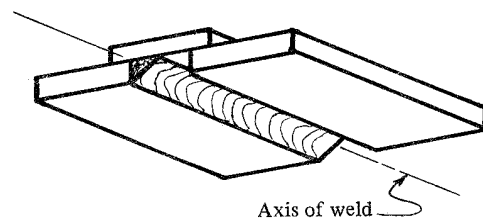

Overhead Position (4F)

FIGURE 810c - POSITIONS OF TEST PLATES FOR FILLET WELDS

811. WELDER QUALIFICATION

811.1 Welder's Classification. Welders shall be classified as shop or field welders based on the following description:

- a) Shop Welder - A person who is employed by the contractor/fabricator to perform welding at the fabrication plant. The shop welder must be qualified by tests conducted at the plant and witnessed by the Inspector.
- b) Field Welder - A person who is employed by the contractor/erector to perform welding in the field. The field welder must be qualified by tests conducted at approved locations and witnessed by representatives of the State.

811.2 Tests Required. Welder qualification tests for manual and semiautomatic welding (shop only) shall be performed using the applicable test plate as follows:

- a) Groove weld test plate as described in Figure 811.2a.
- b) Optional horizontal weld test plate as described in Figure 811.2b. (shop welders only)
- c) Fillet weld test plate as described in Figure 811.2c or if approved by the DCES, AWS D 1.5 Figure 5.22 may be used.

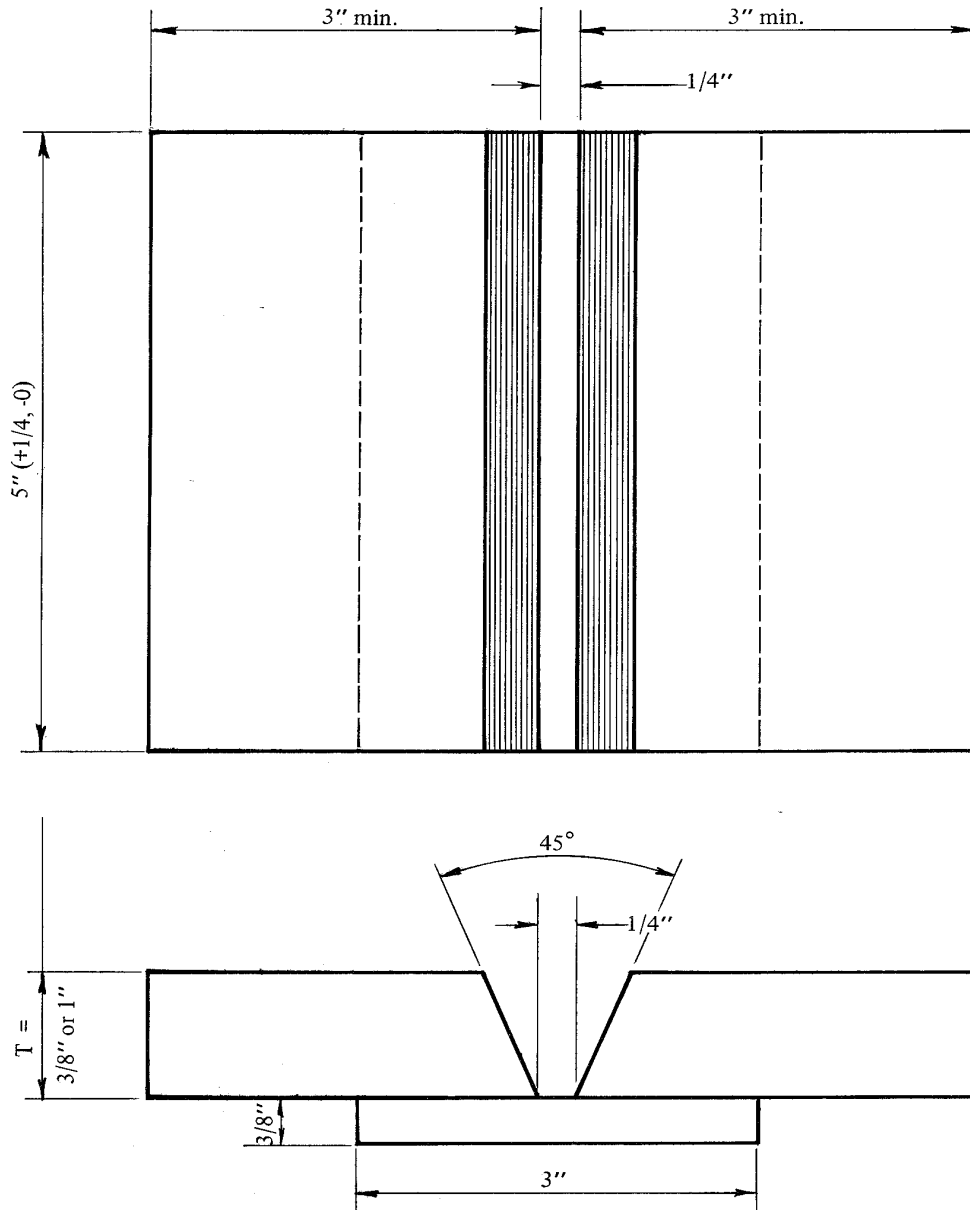

NOTES:

1. All plate surfaces within the area of the backing strip must be free of mill scale and surface depressions. This includes the top and bottom of the test plates and the backing strip.
2. After welding, the weld reinforcement shall be ground flush with the surface of the plate. Grinding on any other surface shall be cause for rejection. Do not remove the backing strip.
3. See Table 811.3 for type and position limitations.
4. T = 3/8 inch qualifies for limited thickness welding up to 3/4 inch (Shop only). T = 1 inch qualifies for unlimited thickness welding. Note: Recertification of Field welder's, as per Section 811.8 may be done on T = 3/8 inch

FIGURE 811.2a WELDER QUALIFICATION TEST PLATE – GROOVE WELDS

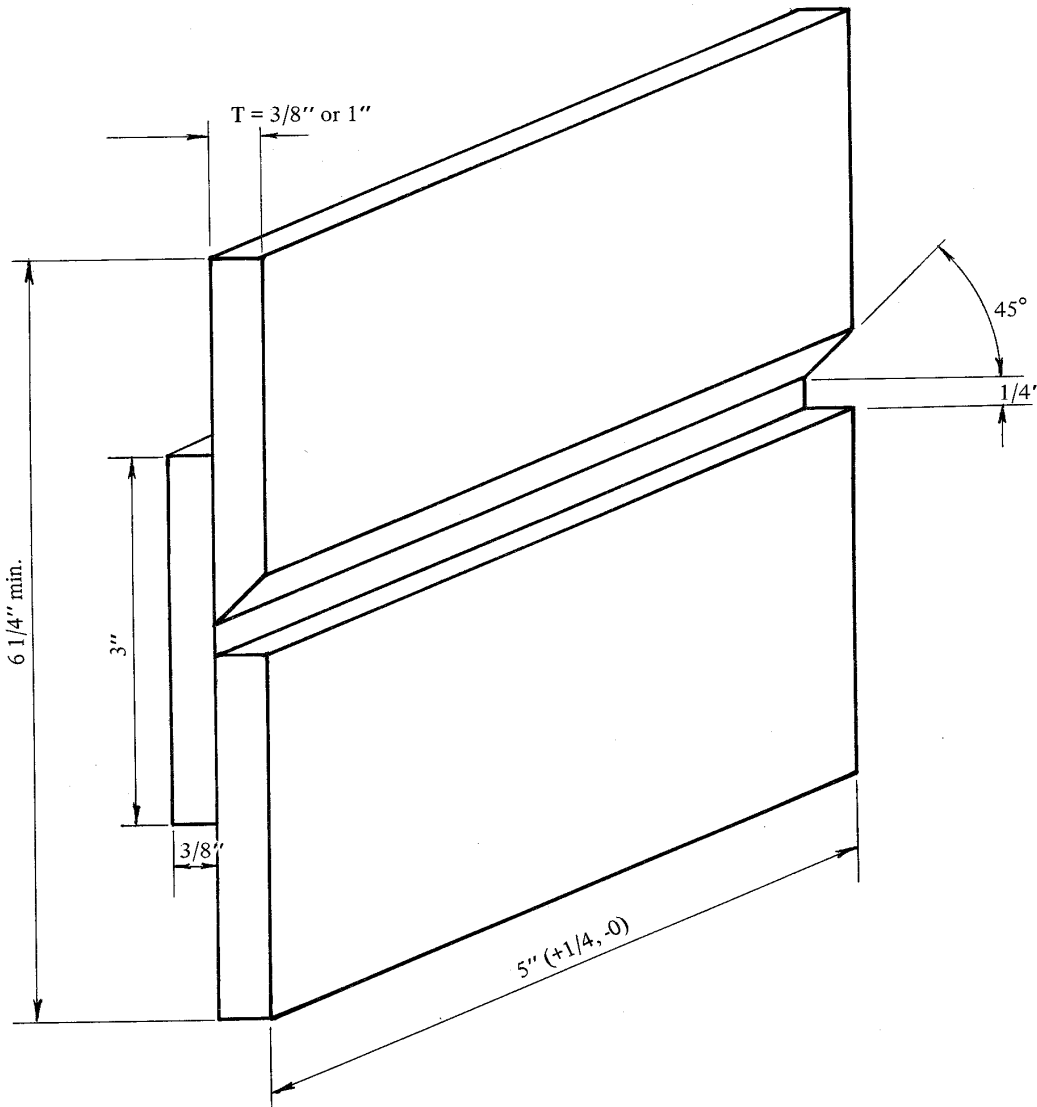

NOTES:

1. All plate surfaces within the area of the backing strip must be free of mill scale and surface depressions. This includes the top and bottom of the test plates and the backing strip.
2. After welding, the weld reinforcement shall be ground flush with the surface of the plate. Grinding on any other surface shall be cause for rejection. Do not remove the backing strip.
3. $T = \frac{3}{8}$ inch qualifies for limited thickness welding up to $\frac{3}{4}$ inch.
4. $T = 1$ inch qualifies for unlimited thickness welding.

FIGURE 811.2b-OPTIONAL WELDER QUALIFICATION TEST PLATE-HORIZONTAL POSITION FOR SHOP WELDERS ONLY

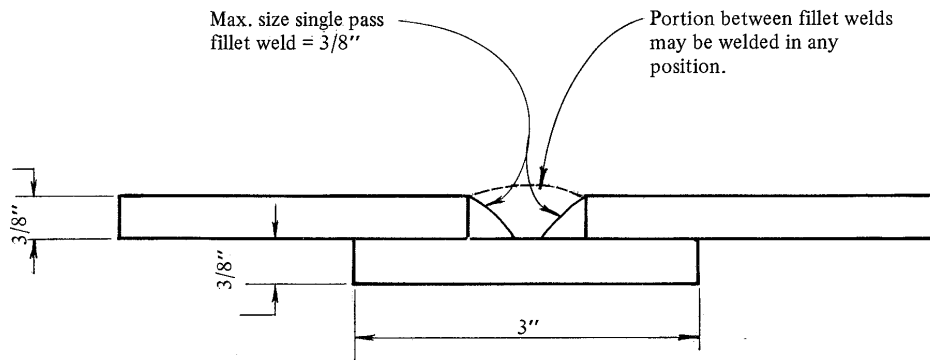
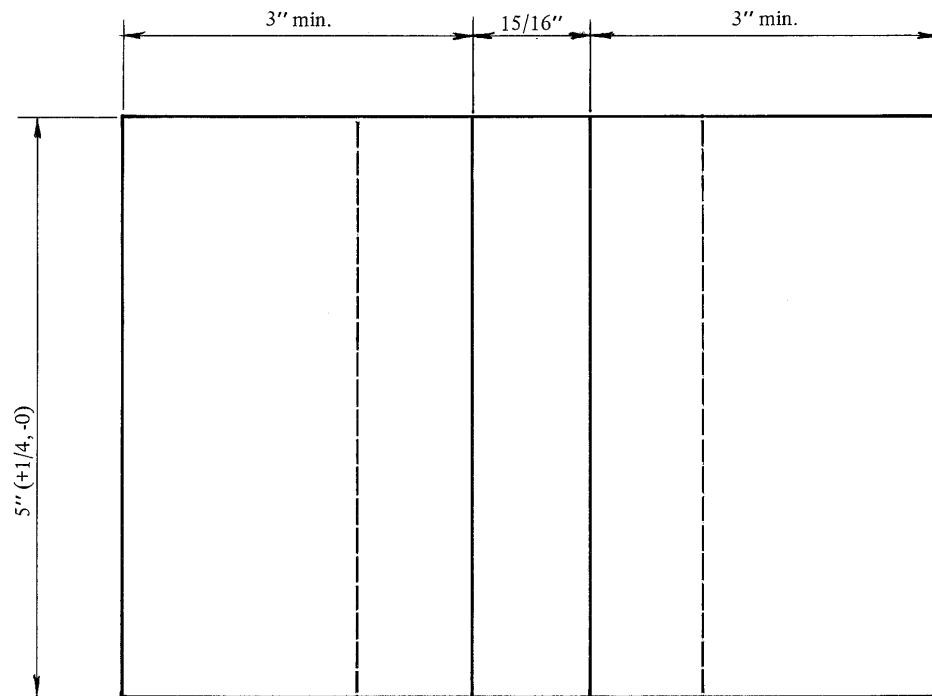

NOTES:

1. All plate surfaces within the area of the backing strip must be free of mill scale and surface depressions. This includes the top and bottom of the test plates and the backing strip.
2. After welding, the weld reinforcement shall be ground flush with the surface of the plate. Grinding on any other surface shall be cause for rejection. Do not remove the backing strip.
3. See Table 811.3 for type and position limitations.
4. Qualifies for unlimited thickness.

FIGURE 811.2c – WELDER QUALIFICATION TEST PLATE – FILLET WELDS

811.3 Position Qualified. The type and position of welds qualified by each test plate position shall be as described in Table 811.3.

TABLE 811.3 - WELDER QUALIFICATION - TYPE AND POSITION LIMITATIONS

Qualification Test		Type of Weld and Position Of Welding Qualified*	
Test Plate	Plate Position	Groove	Fillet
Figure 811.2a and b	1G, Flat 2G Horizontal 3G Vertical 4G Overhead 3G & 4G	F F, H F, H, V F, OH F, H, V, OH	F, H F, H F, H, V F, H, OH F, H, V, OH
Figure 811.2c	1F Flat 2F Horizontal 3F Vertical 4F Overhead 3F & 4F	- - - - -	F F, H F, H, V F, H, OH F, H, V, OH

*Positions of Welding: F = Flat, H = Horizontal, V = Vertical, OH = Overhead

811.4 Welding Procedure. All manual shielded metal arc welder qualification tests shall be performed using $\frac{1}{8}$ inch or $\frac{5}{32}$ inch diameter electrodes conforming to the requirements of the latest edition of AWS A5.1, "Specification for Carbon Steel Covered Arc Welding Electrodes" classification E7018 or AWS A5.5, "Specification for Low-Alloy Steel Covered Arc Welding Electrodes", classification E8018-C3. The welding parameters shall be in accordance with the manufacturer's recommendations.

Qualification of welders for all semiautomatic processes shall be performed using the parameters specified in the approved welding procedure.

All welding shall be performed in accordance with the provisions of this manual.

811.5 Preparation of Test Specimens. The weld reinforcement shall be ground flush with the surface of the test plate. Machining may be used to remove excess weld metal, but the final surface must be produced by grinding. No surface depressions (lines, gouges, nicks, etc.) may remain. The surface roughness shall not exceed 125 microinches.

The thickness of test plates and welds shall not be reduced by more than $\frac{1}{16}$ inch [2 mm] during the grinding process. Plates exceeding these requirements shall be rejected as unfit for testing.

No grinding, air carbon arc gouging, pneumatic chipping or machining of any type will be permitted between weld passes for any purpose. Weld cleaning may only be performed by means of a hand held, non-mechanical chipping hammer and/or wire brush during the weld test. In lieu of wire brush a mechanically powered wire wheel may be used. No grinding wheels will be permitted.

811.6 Method of Testing Specimens. Field welder test specimens shall be submitted, within one week of completion of the test, to the Department of Transportation, Bureau of Materials for radiographic testing in accordance with the provisions of Section 16.

The contractor may radiograph shop welder test specimens in accordance with the provisions of Section 16 and submit film and welder's qualification form signed by the State representative for review, or may submit the test specimens to the Bureau of Materials for testing as described above.

811.7 Test Results. The entire weld shall be radiographed. The area examined shall be in the center portion of the weld length, selected to avoid discontinuities associated with the start and stop of weld passes at the ends of the weld. Any three consecutive inches of the length of the test weld shall be evaluated in accordance with Section 1605 by the DCES.

The welded test plates shall conform to Section 724, Quality of Welds.

811.8 Retests. If a welder fails to meet the test requirements, a retest may be made consisting of two test plates for each type which was failed. In lieu of the above, a single retest may be performed if the welder provides written documentation of additional training.

All retest specimens must meet the requirements of the original test.

811.9 Period of Effectiveness

- a) Shop Welders. Shop welders shall be certified in the shop where the test was performed for a period of three years unless the individual is not engaged in welding by the process for which the welder has qualified for a period exceeding six months, or unless inspection of the work indicates a specific reason to question the welder's ability. Requalification of a welder whose certification has expired may be performed using $\frac{3}{8}$ inch or one inch thick test plates. If certification was withdrawn because of unsatisfactory workmanship, requalification must be performed using the original test.
- b) Field Welders. Field welders shall be certified by a Field Welder's Card for three years provided their work record is maintained as described on the certificate. The work record must be signed at least once every six months by either the Engineer-in-Charge, by a licensed professional engineer or by a Certified Welding Inspector (CWI) to verify that the welder has performed acceptable work. The certificate may be revoked at any time by the DCES if inspection of the work indicates specific reason to question the welder's ability. At the end of the three year period, the welder shall submit the work record to the Region for review. If found acceptable, the Region shall forward the request to the DCES. Based on DCES's review, a new certificate will be issued by the DCES providing the welder has maintained the work record properly. If the welder is not engaged in welding for which the welder has qualified for a period exceeding six months, or if the work record is not maintained, the welder shall not be allowed to weld on NYS projects. The welder shall perform a requalification test(s) using $\frac{3}{8}$ inch or one inch thick test plates for each position. If certification was withdrawn because of unsatisfactory workmanship, requalification must be performed using the original test.

811.10 Records

- a) Shop Welders. Records of test results for shop welders shall be kept by the fabricator or contractor and shall be available to representatives of the State upon request.
- b) Field Welders. Records of test results for field welders shall be kept by the DCES.

812. WELDING OPERATOR QUALIFICATION

812.1 Tests Required. The welding operator qualification tests for automatic welding processes shall be performed as follows:

- a) The qualification test plates for automatic submerged arc welding or automatic flux cored arc welding shall be as shown in Figure 812.1a. This test shall qualify the welding operator for making groove welds in the flat position and fillet welds in the flat and horizontal position on material of unlimited thickness with the process tested.

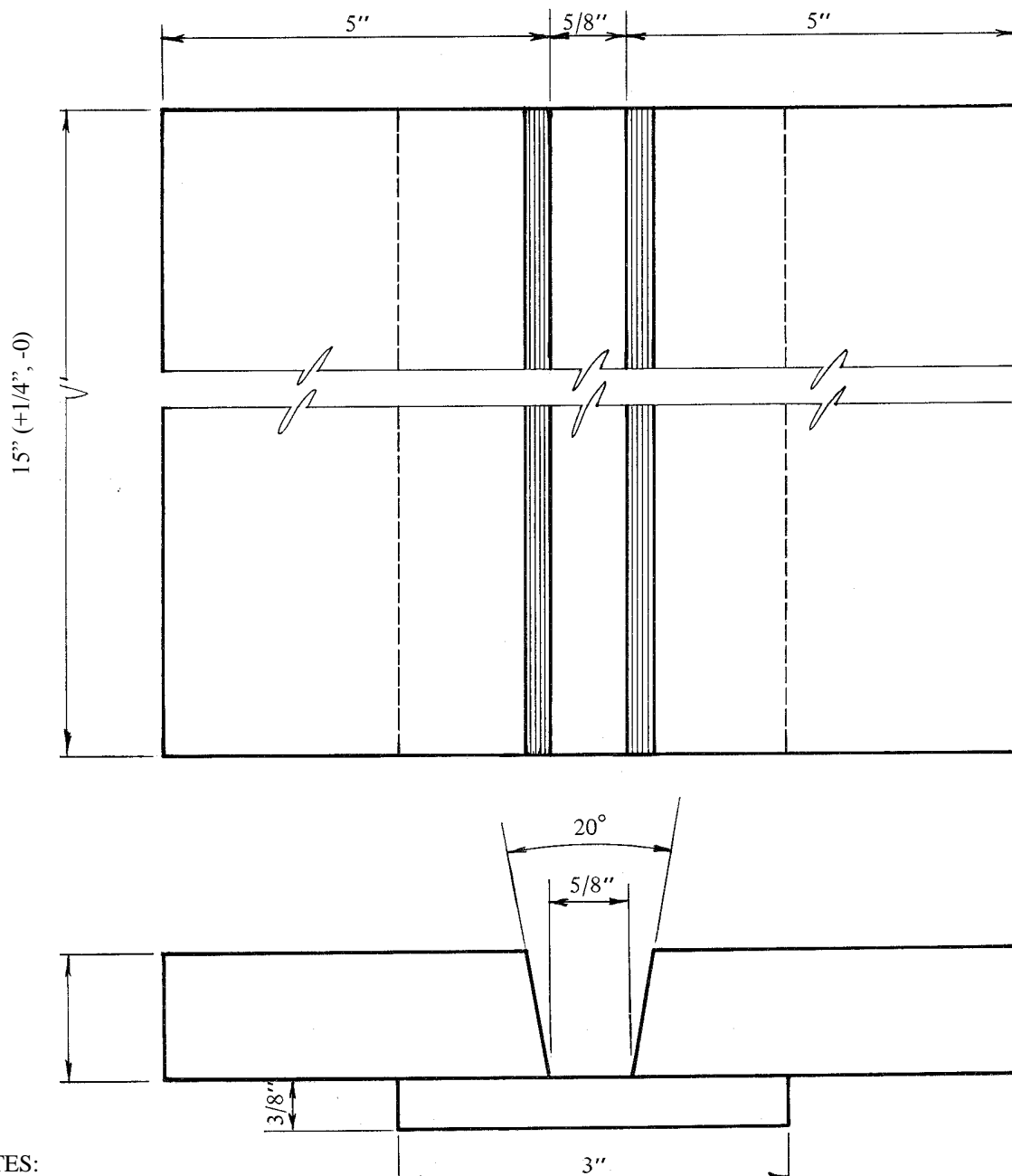

NOTES:

1. All plate surfaces within the area of the backing strip must be free of mill scale and surface depressions. This includes the top and bottom of the test plates and the backing strip.
2. After welding, the weld reinforcement shall be ground flush with the surface of the plate. Grinding on any other surface shall be cause for rejection. Do not remove the backing strip.
3. For flat position and material of unlimited thickness.

FIGURE 812.1a - WELDING OPERATOR QUALIFICATION TEST PLATE FOR AUTOMATIC SUBMERGED ARC AND AUTOMATIC FLUX CORED ARC WELDING

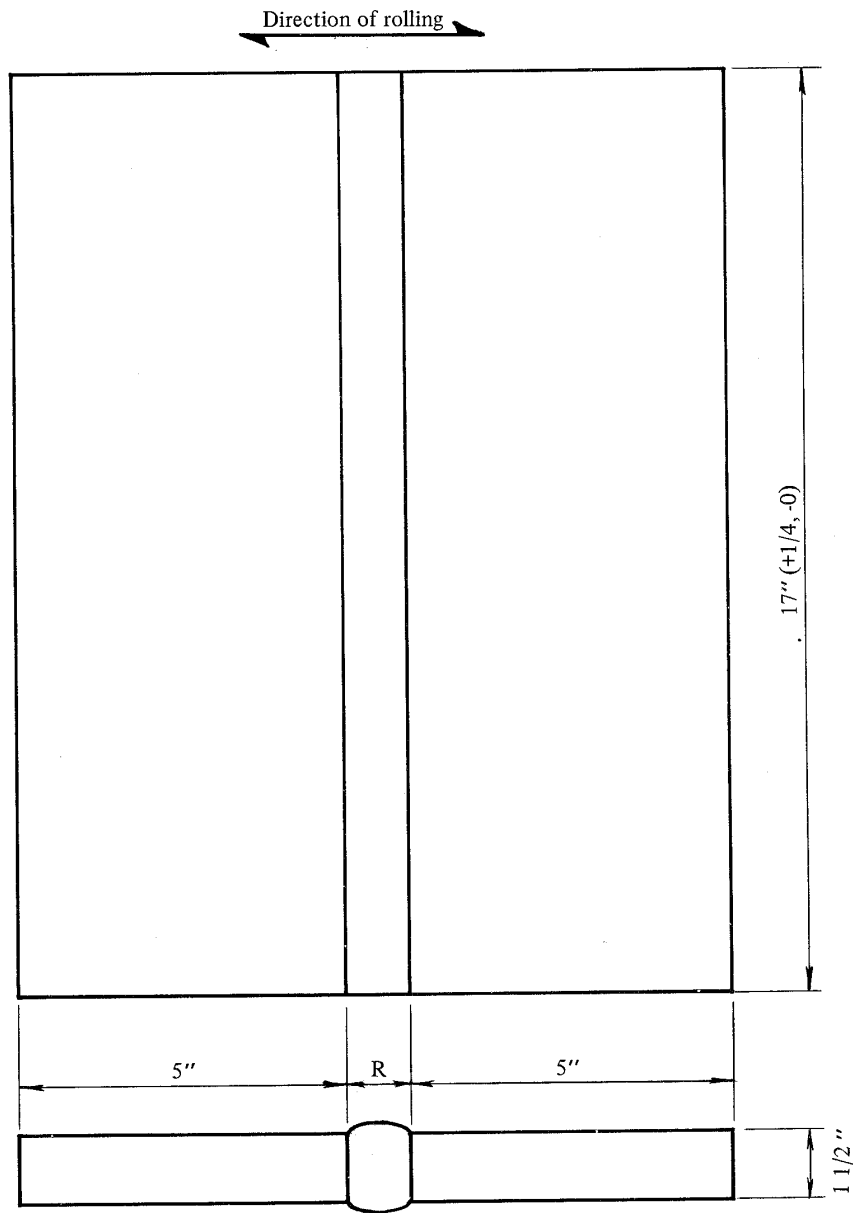

Root opening "R" established by procedure specification

**FIGURE 812.1b – WELDING OPERATOR QUALIFICATION TEST
PLATE FOR ELECTROSLAG AND ELECTROGAS WELDING**

812.2 Welding Procedure. Qualification of welding operators for automatic processes shall be performed using the parameters specified in the approved welding procedure.

All welding shall be performed in accordance with the provisions of this manual.

812.3 Preparation of Test Specimens. The weld reinforcement shall be ground flush with the surface of the test plate. Machining may be used to remove excess weld metal, but the final surface must be produced by grinding. No surface depressions (lines, gouges, nicks, etc.) may remain. The surface roughness shall not exceed 125 microinches.

The thickness of test plates and welds shall not be reduced by more than $1/16$ inch during the grinding process. Test plate exceeding these requirements shall be rejected as unfit for testing.

No grinding, air carbon arc gouging, pneumatic chipping or machining of any type will be permitted between weld passes for any purpose. Weld cleaning may only be performed by means of a hand held, non-mechanical chipping hammer and/or wire brush during the weld test.

812.4 Method of Testing Specimens. The test plate shall be radiographed by the Contractor or the State in accordance with the provisions of Section 16.

812.5 Test Results. The entire weld shall be radiographed. The area examined shall be in the center portion of the weld length, selected to avoid discontinuities associated with the start and stop of weld passes at the ends of the weld. Any 12 consecutive inches of the length of the test plate shall be evaluated in accordance with Section 1605 by the DCES.

The welded test plate shall conform to Section 724, Quality of Welds.

812.6 Retests. If a welding operator fails to meet the test requirements, a retest may be made consisting of two test plates for each type which failed. In lieu of the above, a single retest may be performed if the welder provides written documentation of additional training.

All retest specimens must meet the requirements of the original test.

812.7 Period of Effectiveness. Welding operators shall be certified for three years unless the individual is not engaged in welding for which the welder has qualified for a period exceeding six months, or unless inspection of the work indicates a specific reason to question the welding operator's ability. Requalification of a welding operator shall be performed using the test plate described for the original test.

812.8 Records. Records of test results shall be kept by the manufacturer or contractor and shall be available to representatives of the State upon request.

813. TACKER QUALIFICATION

813.1 Tests Required. The tacker qualification tests for manual and semiautomatic welding shall be performed as described in Figure 813.1. The tacker shall make a $1/4$ inch maximum size tack weld approximately 2 inches long.

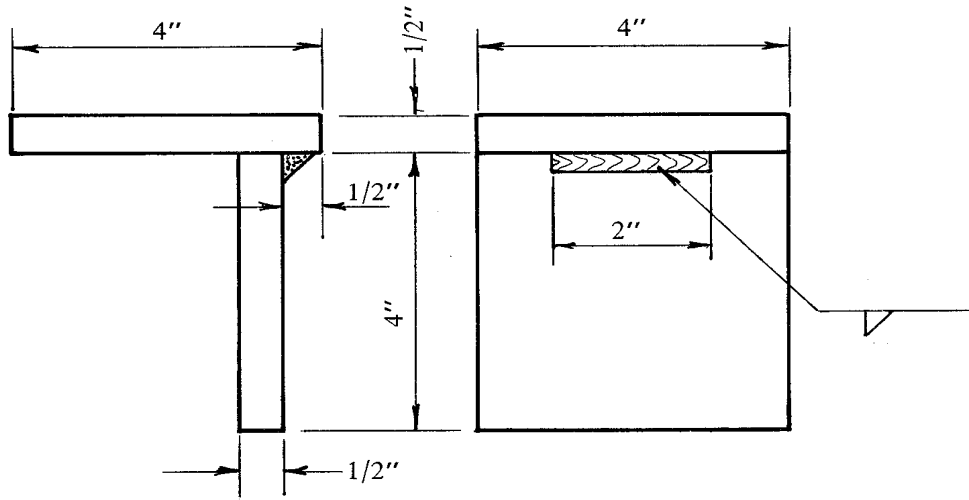

FIGURE 813.1 – FILLET WELD BREAK SPECIMEN

813.2 Positions Qualified. The positions qualified by each test plate position shown in Figure 813.2 shall be as described in Table 813.2.

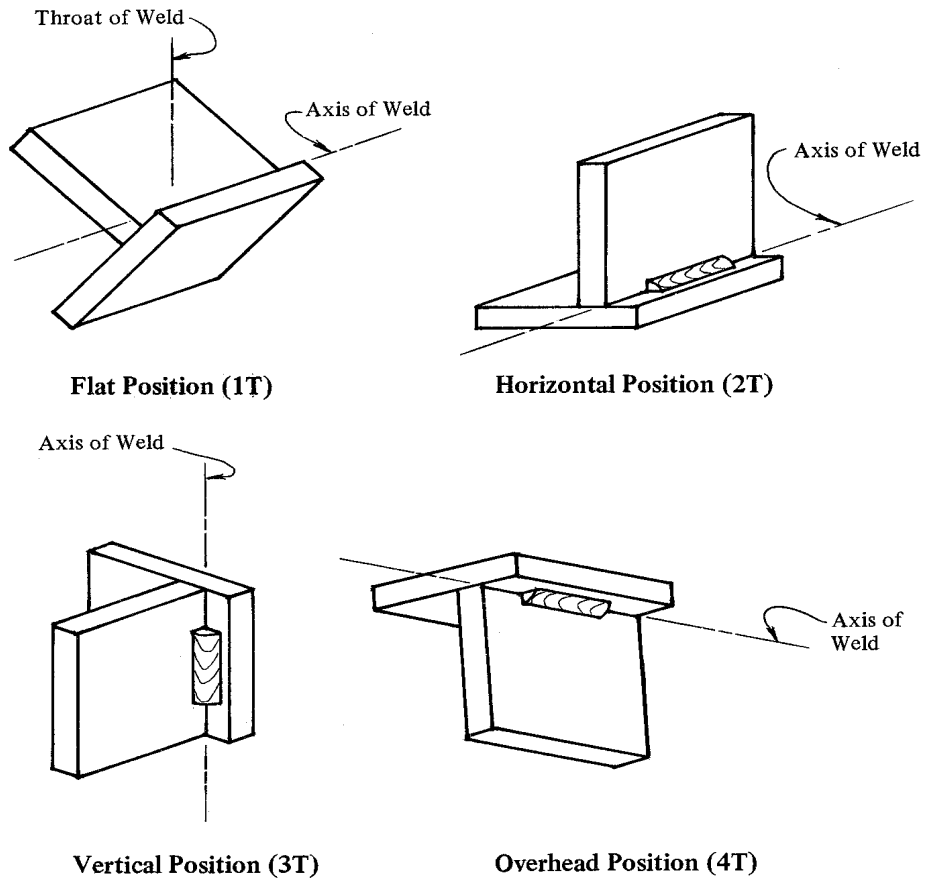

FIGURE 813.2- POSITION FOR TACKER TEST PLATES

813.2 – TACKER QUALIFICATION – POSITION LIMITATIONS

Test Position	Position Qualified*
1T Flat	F
2T Horizontal	F, H
3T Vertical	F, H, V
4T Overhead	F, H, OH
3T & 4T	F, H, V, OH

*Position of Welding: F = Flat, H = Horizontal,
V = Vertical, OH = Overhead

813.3 Welding Procedure. All manual shielded metal arc tacker qualification tests shall be performed using $\frac{5}{32}$ inch diameter electrodes conforming to the requirements of the latest edition of AWS A5.1, "Specification for Carbon Steel Covered Arc Welding Electrodes" classification E7018 or AWS A5.5, "Specification for Low-Alloy Steel Covered Arc Welding Electrodes", classification E 8018-C3. The welding parameters shall be in accordance with the manufacturer's recommendations.

Qualification of tackers using all semiautomatic processes shall be performed using the parameters specified in the approved welding procedure.

All tacking shall be performed in accordance with the provisions of this manual.

813.4 Method of Testing Specimens. A force shall be applied to the specimen as shown in Figure 813.4 until rupture occurs. The force may be applied by any convenient method. The surface of the weld and the fracture shall be examined visually for defects.

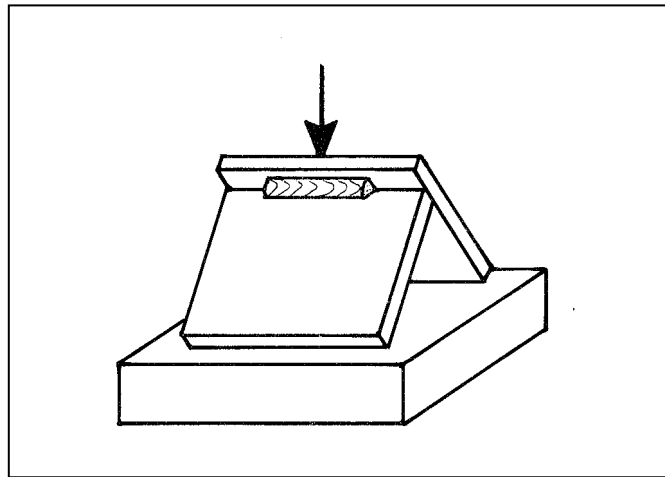

FIGURE 813.4 – METHOD OF RUPTURING TACKER TEST SPECIMEN

813.5 Test Results Required. A visual inspection of the specimen before the tack weld has been ruptured shall show that the tack weld has a reasonably uniform appearance, free of overlap, cracks, and excessive undercut. There shall be no porosity visible on the surface of the tack.

The fractured surface of the tack weld shall show fusion at the root, but not necessarily beyond, and shall exhibit no incomplete fusion to the base metal or any inclusion or porosity larger than $\frac{3}{32}$ inch in greatest dimension.

813.6 Retests. If the tacker fails to meet the test requirements, one retest may be made without additional training. If the tacker fails the retest, the tacker will be required to show evidence of additional training or practice prior to performing an additional test.

SECTION 9 FRACTURE CONTROL PLAN

901. GENERAL

Fracture critical members or member components (FCM's) are tension members, or tension components of members, whose failure would be expected to result in collapse of the structure.

Tension components of bridge members consist of components of tension members and those portions of flexural members that are subject to tensile stress. Members and components that are not subject to tensile stress under any condition of liveload shall not be defined as fracture critical.

Any attachment that is welded to a tension or reversal zone of a fracture critical member for more than 4 inches in the direction parallel to the tension stress shall be considered part of the tension component and therefore fracture critical.

All welds to FCM members shall be considered FCM welds. Welds to compression members or compression areas of bending members shall not be defined as fracture critical. FCM welds shall be identified on the shop drawings with the weld designation "FCW."

Examples of FCM's are the tie girders of a tied-arch bridge, steel pier cap beams, the girders of a two-girder bridge, the tension web and chord members of trusses, suspended span hangers and other nonredundant parts supporting the superstructure.

Fracture critical members shall be identified on the plans by appropriate notations to call the Contractor's attention to special testing and fabrication requirements.

All provisions of the SCM shall apply to fracture critical members except as modified by this section and special notes that may be placed in the Contract Documents to reflect special requirements of individual structures.

902. SHOP DRAWING REVIEW

Shop drawings shall be reviewed as described in Section 2. The shop drawings shall list material requirements and show necessary details to ensure conformance with this Section and other provisions of the Contract Documents, if any.

The shop drawing for each FCM which is repaired in accordance with Category III as described in Section 909.2 shall be revised to include a note referring to the approved repair procedure.

903. FABRICATOR QUALIFICATION

For fabrication of FCM, the structural steel fabricator shall have adequate personnel, organization, experience, procedures, knowledge, equipment and plant capable of producing quality workmanship. In addition, prior to fabrication, all steel fabricators must meet one of the following:

- AISC certified for steel bridge fabrication, with Fracture Critical Endorsement.
- Performed similar satisfactory fracture critical bridge fabrication for NYSDOT within the last 5 years.
- Approved by the DCES to perform fracture critical bridge fabrication.

Additional criteria contained in the contract documents may be required for the fabrication of extremely complicated structures, such as innovative and movable steel bridges.

904. BASE METAL REQUIREMENTS

904.1 General. All requirements of the Standard Specifications, Materials Section entitled Structural Steel, shall apply with modifications listed herein or in the Contract Documents.

Fracture critical plates and shapes shall be produced to be fully killed fine grain.

All FCM plates shall be rolled on a "sheared-mill" and furnished with thermal cut edges conforming with the requirements of Section 6, Preparation of Base Metals.

904.2 Toughness Requirements. Fracture critical plates and shapes shall be sampled and tested to determine the Charpy V-Notch (CVN) Impact Toughness in accordance with the requirements of ASTM A673. Sampling and testing shall be performed at the P Frequency, modified to include impact tests at each end of each plate ("PP" frequency). The CVN specimens shall be coded with the heat and plate number, and that code shall be recorded on the certified mill test report with the test results. If requested, the tested specimens shall be forwarded to the DCES for review. The impact test shall consist of three specimens taken from each test location. The average impact energy shall meet the minimum requirements of Table 904. If the energy value from more than one of three test specimens is below the specified minimum average, or, if the energy value for one specimen is less than or two-thirds ($\frac{2}{3}$) of the specified minimum, a retest of three additional specimens shall be made and the energy value from each specimen shall equal or exceed the specified minimum average. Longitudinal CVN tests shall be performed and reported for each shape or plate as-rolled or as-heat treated.

Heat treatment may be required to produce the toughness listed in Table 904 or specified in the Contract Documents. When not specified in the Contract Documents, the heat treatment, if any, necessary to produce the required CVN toughness, shall be the option of the Contractor.

Under special conditions, the DCES may specify CVN toughness values that, when tested at the lowest anticipated service temperature, are significantly greater than those listed in Table 904.

904.3 Blast Cleaning & Visual Inspection. All surfaces of fracture critical plates and shapes shall be blast cleaned and visual inspected by the QC and QA Inspector prior to the start of any work on the steel. Blast cleaning shall be performed in the shop to aid the inspection of surfaces for injurious defects and to facilitate welding. Blast cleaning shall conform to the requirements of the Steel Structures Painting Council Surface Preparation No.6 (SSPC-SP-6) - Commercial Blast Cleaning, as described in the Standard Specifications, Materials Section entitled Painting Metal Structures.

904.4 Repairs to Base Metal. There shall be no conditioning of fracture critical plates or shapes by welding at the mill. Repairs may be made by welding at the shop in the presence of the QA Inspector. All repair welding shall be performed in accordance with Section 909.

All repair welds shall be subject to nondestructive tests and shall meet the requirements for quality of welds as described in this manual.

905. WELDING PROCESSES

The Manual Shielded Metal Arc Welding, Submerged Arc Welding, and Flux Cored Arc Welding – Gas Shielded processes may be used for the fabrication of fracture critical members. The Gas Metal Arc Welding processes shall not be used for the fabrication of fracture critical members. Welding processes approved for use in the construction of FCM's shall be qualified by tests described in this section.

906. WELDING

906.1 General. The welding requirements of this manual shall apply as modified herein. Field welding shall not be permitted unless approved by the DCES.

**TABLE 904 - FCM TOUGHNESS REQUIREMENT
FOR BASE METAL**

ASTM Designation A709	Thickness	<i>Average Minimum Toughness and Test Temperature^a</i>
36	up to 4 inches	25 ft lbs at 40°F
50 ^b and 50W ^b	up to 2 inches over 2 to 4 inches	25 ft lbs at 40°F 30 ft lbs at 40°F
HPS50W ^c HPS70W ^c	up to 4 inches up to 4 inches	30 ft lbs at 10°F 35 ft lbs at -10°F
a) Minimum service temperature from -1°F to -30°F b) If the yield strength of the steel exceeds 65 ksi, the temperature for the CVN test for acceptability shall be reduced by 15°F for each increment of 10 ksi above 65 ksi. The yield strength is the value given in the certified mill test report. c) If the yield strength of the steel exceeds 85 ksi, the temperature for the CVN test for acceptability shall be reduced by 15°F for each increment of 10 ksi over 85 ksi. The yield strength is the value given on the certified mill test report (MTR).		

906.2 Preheat and Interpass Temperature. Preheat and interpass temperatures shall conform to the requirements of Section 708 except as modified in Table 906.2.

**TABLE 906.2 - MINIMUM PREHEAT AND
INTERPASS TEMPERATURE FOR
WELDING FRACTURE CRITICAL MEMBERS - (DEGREES F)**

Thickness of Thickest Part at Point of Welding(inches)	ASTM A709- 36 & 50	ASTM A709- 50W & 70W
To ¾, inclusive	100	100
Over ¾ to 1 ½	150	200
Over 1 ½ to 2 ½	200	300
Over 2 ½	300	350

906.3 Electrode and Electrode/Flux Requirements. All consumables shall be of a low hydrogen classification and shall conform to the AWS filler metal specification optional supplemental designator H4 or H8.

The diffusible hydrogen content of weld metal deposited by the SMAW, SAW, and FCAW-G processes shall be measured by tests performed by the electrode, or electrode/flux manufacturer. Tests shall be conducted to determine the diffusible hydrogen content of weld metal produced using the consumables to be used in the work. The manufacturer shall provide the Fabricator with a written description of the storage and operating requirements that must be followed to keep the diffusible hydrogen content of the deposited weld metal below an average of 4 milliliters per hundred grams for SMAW and 8 milliliters per hundred grams for SAW and FCAW-G when measured as an average of three tests. Diffusible hydrogen shall be performed under mercury or by the gas chromatograph method as specified in AWS A4.3 *Standard Methods for Determination of the Diffusible Hydrogen Content of Martensitic, Bainitic and Ferritic Steel Weld Metal Produced by Arc Welding*.

906.4 Storage of Electrodes. SMAW electrodes, when removed from the sealed container shall be stored in electrode ovens at 250° F until dispensed. Ovens shall be capable of maintaining temperature between 250°F and 550°F. If the temperature inside the oven falls below 225°F for a period of up to eight hours, or below 125°F for up to four hours, all electrodes shall be dried at a temperature of 450°F and 550°F for a minimum of four hours or shall not be used for FCM welds. After removal, E7018 and E8018-C3 electrodes shall not be exposed to the atmosphere for periods greater than 4 hours and 2 hours respectively. Electrodes exposed to the atmosphere for periods greater than those specified shall be dried or not used as noted above.

906.5 Storage of Wires and Fluxes. All submerged arc fluxes shall be baked at 550°F, with the exception of MIL800-H, MIL800-HPN_i, and 8500 which shall not be dried above 450°F, for two hours minimum and shall be stored at 250°F minimum after drying. The recycling of fluxes shall be controlled to avoid pickup of materials that may cause an increase in the hydrogen content of the deposited weld metal or otherwise interfere with the production of sound welds. The Fabricator shall submit a description of the flux recycling program to the DCES for approval. Fluxes left unused in the welding machine hopper(s) more than ten hours shall be replaced with flux that has been baked as described above. Open top hopper that have not been refilled or if welding has been suspended for six hours, the top 3/8 inch of flux shall be removed and discarded.

906.6 Requirements for Backing and Runoff Plates. Welds shall be terminated as per Section 714. For fracture critical members such as boxes made with CJP welds, the backing material that will remain shall be ordered to the same charpy value as the joined steel in conformance with Section 715. Groove Weld Backing.

907. WELDING PROCEDURE QUALIFICATION

907.1 General. The welding procedure shall be qualified not more than twelve months prior to use by tests described in Figure 907. The base metal shall be of the same ASTM specification as that to be used in the FCM. Qualification of a welding procedure shall be accomplished using welding consumables supplied under the same AWS specification and shall be produced by the same manufacturer as those to be used in the FCMs. All welding consumables that are produced in accordance with Section 12.6.1.1 of AWS D1.5-2002 are exempt for heat and/or lot testing, provided certification to that fact is forwarded to the DCES. For consumables not produced in accordance with Section 12.6.1.1, each heat and/or lot shall be pretested in accordance with the applicable AWS specification, and certified test results shall be furnished to the DCES. Lots and heats are as defined in the latest edition of AWS A5.01, Filler Metal Procurement Guidelines.

At the discretion of the DCES, the Department may accept evidence of previous qualification of a welding procedure provided the qualification tests were performed in accordance with the requirements of this section.

Weld joint details that conform in all respects to the provisions of Section 7A are considered prequalified.

907.2 Weld Metal Toughness. The toughness requirements specified herein are mandatory minimum values for qualifying the welding procedures used in all welding of fracture critical members. The minimum average Charpy V-Notch impact strength of weld metal joining all ASTM A709 steels shall be 25 foot-pounds when tested at minus 20° F.

907.3 Groove Welding Procedures. Qualification of groove welding procedures shall be based on the results of mechanical tests. A chemical analysis of the all-weld material shall be performed for unpainted weathering steels applications. One test shall be made with "T" equal to one inch for groove welding material up to 1½ inch thick and one test shall be made with "T" equal to the maximum groove thickness to be welded in construction, provided the maximum is equal to or greater than one and one-half inches, except that the maximum test plate thickness need not exceed two inches. Test specimens shall be removed and prepared for testing as described in Figure 907. All mechanical testing shall conform to the requirements of Section 806.

907.4 Fillet Welding Procedures. Qualification of fillet welding procedures shall be as described in Section 804.g Fillet Weld Macroetch Test. The thickness of the weld procedure test plates shall be 1 inch.

All weld passes used to make the fillet weld shall be made using weld procedure variables from the approved PQR that will produce the highest anticipated heat input to be used in the work, i.e., maximum amperage, maximum voltage and minimum travel speed.

908. QUALIFICATION OF WELDERS, WELDING OPERATORS, AND TACKERS

All welders, welding operators and tackers to be employed in the fabrication of fracture critical members shall be qualified by tests performed within six months prior to the start of fabrication, or shall be regularly requalified by testing on an annual basis provided there are no gaps in the welder's work experience that exceed six months as provided on Section 8B.

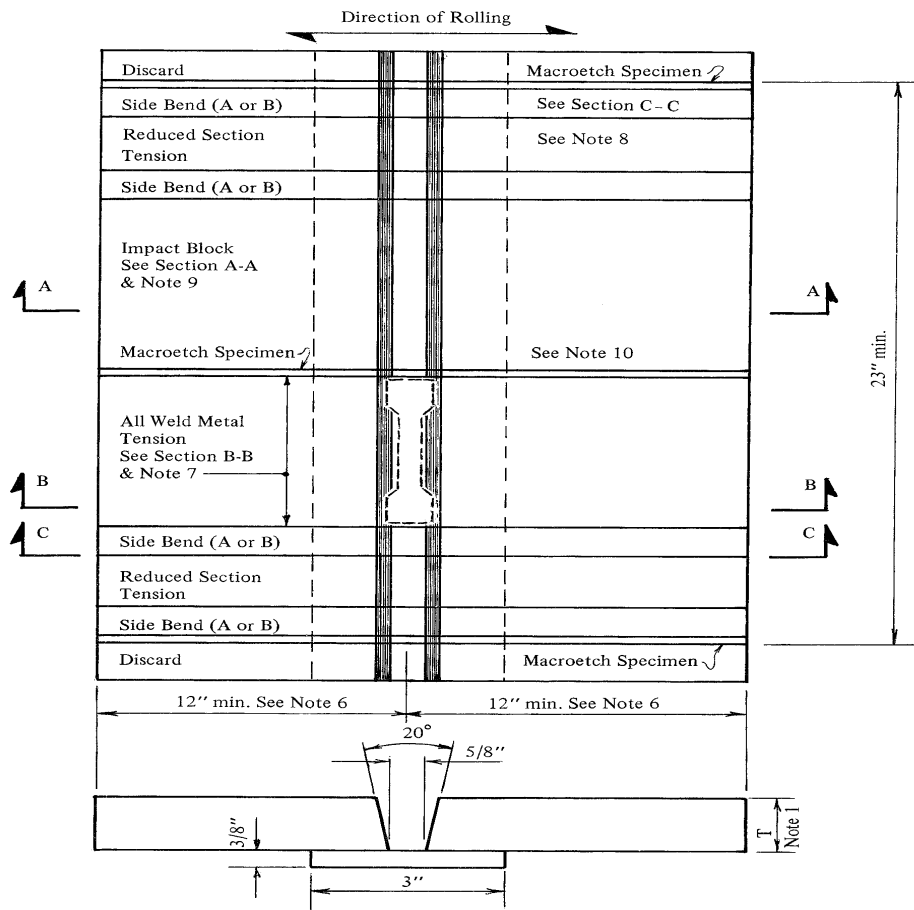
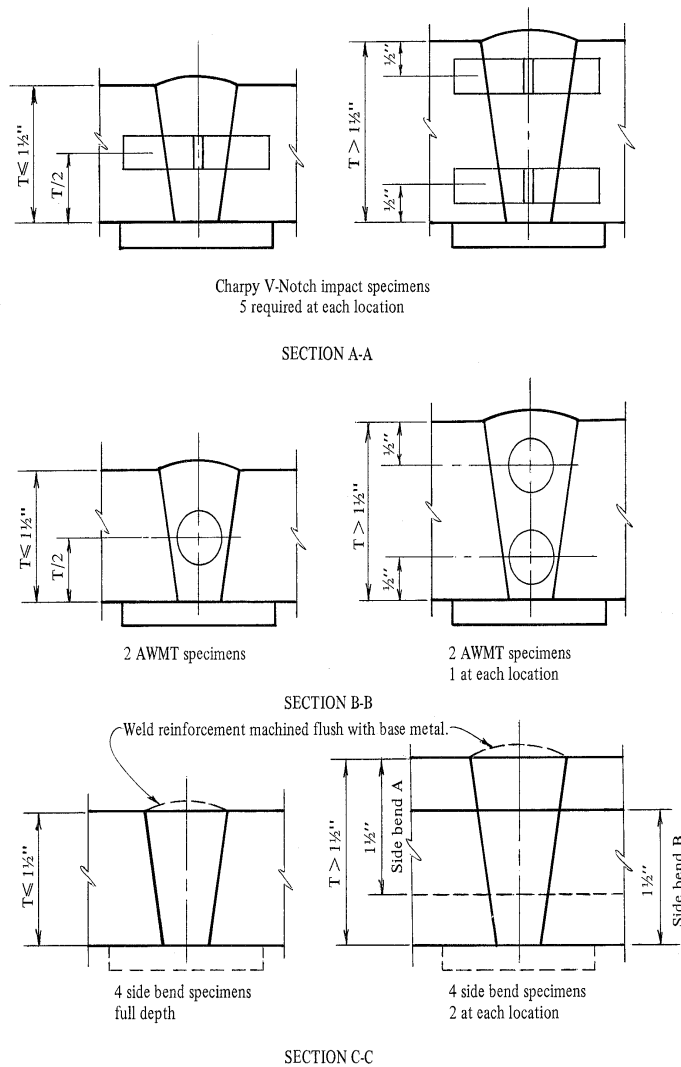

FIGURE 907 – PROCEDURE QUALIFICATION TEST PLATE (FCM)



NOTE: 1. For machined dimensions of test specimens, see Section 8A
2. Weld backing to be removed during specimen preparation

FIGURE 907 (continued)

NOTES:

1. See Sections 907.3 and 907.4 for required thickness "T" of test plates.
2. All test plate material shall have proper heat identity. The certified mill test reports shall demonstrate that test material is the same ASTM designation as the material specified for the fabrication of FCM's.
3. The minimum preheat and interpass temperatures shall be in accordance with Table 905.2.
4. Welding shall be witnessed by the Inspector.
5. Machined test specimens and the Welding Procedure Qualification Record listing all welding parameters used to make the test weld shall be submitted to the DCES as provided in Section 8A.
6. This dimension may be increased as required for testing the reduced section tension specimens, depending on the plate thickness and the requirements of the testing equipment.
7. This dimension must be increased to provide for 2 AWMT specimens when the test plate thickness is 1 1/2 inches or less.

8. The reduced section tension specimen shall be in accordance with Section 8A except that the thickness shall be equal to the test plate thickness.
9. Toughness testing shall be performed as described in Section 806. Only full size (10 mm x 10 mm) specimens shall be used.
10. Specimens shall be removed for macroetch testing. Specimens shall be 3/8 inch in width. At least one cut face of each specimen shall be polished and etched for macroscopic examination by the DCES.

909. REPAIR WELDING

909.1 General. Repair welding is defined as any welding, including removal of weld or base metal in preparation for welding, necessary to correct defects in materials or workmanship.

Repair welding may be performed using any of the welding procedures qualified for use in the fabrication of FCM's. All repair welding shall be subject to nondestructive tests as provided herein.

Weld repair of base metal at the producing mill shall not be permitted.

909.2 Types of Repairs. All repairs to base and weld metal shall be classified as one of the following three categories as determined by the DCES.

Category I repairs may be performed without documentation or prior approval of the DCES. These repairs shall include the following:

- a) Deposition of additional weld metal to compensate for insufficient weld throat.
- b) Deposition of additional weld metal to fill shallow excavations produced by grinding to remove small discontinuities.
- c) Repair of overlap.
- d) Repair of undercut.

Category II repairs shall be documented as described in Section 909.3. The Contractor may prepare repair procedures for Category II repairs and submit them to the DCES for preapproval. Preapproved procedures may be employed after the QA Inspector has verified that the discontinuity to be repaired is as described in the approved procedure. These repairs shall include the following:

- a) Repair of gouges in cut edges that are 7/16 inch deep or less.
- b) Repair of laminar discontinuities less than one inch deep, or with a depth of less than one-half the thickness of the plate cut edge, whichever is less, provided that the laminar discontinuity is not within 12 inches of a tension groove weld. There shall be no visible lamellar discontinuities at the boundaries of tension groove welds.
- c) Repair of base metal surfaces when ASTM A6 provides for repair welding.
- d) First time excavation and repair from one surface of groove and fillet welds which contain porosity, slag, or incomplete fusion, provided the excavations do not exceed the following limits:

<u>Length of Weld "L"</u>	<u>Total Length of Excavations</u>
Up to 1'-6"	"L" or 10", whichever is less
Over 1'-6" to 3'-0"	1'-0"
Over 3'-0" to 6'	1'-6"
Over 6'-0" to 12'-0"	2'-0"
Over 12'-0" to 24'-0"	3'-0"
Over 24'-0"	3'-0" or 10 percent, whichever is greater

The depth of groove weld excavations shall not exceed 65 percent of the effective throat of the weld detailed on the shop drawings. Excavations beyond this depth shall be treated as Category III repairs.

- e) Repair of "hot" or "restraint" cracks which are confined to root passes.
- f) Repair of cracks in the "dead end" of a member which initiated from residual stress and could not propagate due to the absence of applied stress.
- g) Deposition of weld metal up to $\frac{3}{8}$ inch or one quarter the material thickness, whichever is less, to correct for length, thickness or joint geometry.

Category III repairs shall be documented as described in Section 909.3. The Contractor shall prepare repair procedures on an individual basis and submit them to the DCES for approval before repair welding is begun. These repairs shall include the following:

- a) Repair of gouges in cut edges greater than $\frac{7}{16}$ inch deep.
- b) Repair of all laminar discontinuities other than Category II repairs.
- c) Repair of surface or internal defects in rolled, forged or cast products, other than Category II repairs.
- d) Repair of weld defects other than Category I or II repairs.
- e) Repair of all cracks, including base metal separations such as lamellar tears, other than Category II repairs.
- f) Dimensional corrections requiring weld removal and rewelding.
- g) Any weld correction to compensate for a fabrication error such as improper cutting, punching, drilling, machining, fitting, assembly, etc.

909.3 Repair Procedures. Repair procedures shall include full-size drawings in accordance with Section 2 to adequately describe the deficiency and proposed method of repair. Category III repair procedures shall detail the location of the discontinuity in the member. Repair procedures shall be in accordance with Section 726 except as modified below:

- a) The discontinuity shall be detailed as it appears from visual inspection and NDT.
- b) Preheat prior to air carbon arc gouging shall be shown. The minimum preheat shall be 150°F. Applied stresses shall be removed prior to initiating the repair.
- c) Preheat and interpass temperature shall be shown. ASTM A709 steels with thicknesses up to 1½ inches shall be heated to 250°F minimum. Thicknesses above 1½ inches shall be heated to 350°F minimum. Preheat and interpass temperatures shall be maintained without interruption until the repair is completed unless otherwise approved by the DCES.
- d) Postheat shall be employed and shall continue without interruption from the completion of repair welding to the end of the minimum specified postheat period. Postheat of the repair area shall be between 400°F and 500°F for one hour minimum for each inch of thickness of base material. If the repair is in an area where components are of unequal thickness, the largest thickness value will govern.
- e) Preheat, interpass temperature maintenance during repair, and post heat shall be contiguous operations.
- f) If stress relief heat treatment is required, it shall be completely described. Tests shall be performed to determine the effect of the heat treatment on both weld and base metal properties before the procedure is approved. Final acceptance NDT shall be performed after stress relief is complete.
- g) Repairs to tension butt welds shall be examined by ultrasonic and radiographic testing. Repairs to all other groove welds shall be examined by ultrasonic and/or radiographic testing as approved by the DCES. Fillet weld repairs shall be examined by magnetic particle testing. Radiographic testing may be performed as specified in Section 910 as soon as the weldment has cooled to ambient temperature. Final testing by ultrasonic or magnetic particle testing shall not be performed until the weldments have been cooled to ambient temperature for at least the elapsed time indicated as follows:

ASTM A709
 <2" 24 hrs.
 > 2" 48 hrs.

Approved repair procedures shall be retained as part of the Contract records. The Contractor shall provide one copy of each approved repair procedure to the QA Inspector for submission to the DCES with the Inspector's final inspection report.

910. RADIOGRAPHIC TESTING

Radiographic Inspection of FCM's or components of FCM's shall be performed in accordance with the provisions of Section 16 of this Manual, except that the thickness of the penetrameter and the essential hole shall be as specified in Table 910. A smaller essential hole and/or a thinner penetrameter than specified may be used.

In addition to the film identification required by Section 16, the letters "FCM" shall appear on each radiograph. The FCM images shall appear adjacent to the weld number and shall be obtained by placing lead letters on the steel on the source side prior to exposure. The minimum height of the lead letters shall be ⁵/₁₆ inch.

Radiographs shall be identified in the Radiographic Inspection Report by the designation "FCM" adjacent to the weld identification.

TABLE 910 - PENETRAMEETER REQUIREMENTS FOR FRACTURE CRITICAL MEMBERS*

Nominal material Thickness range (inches)	Penetrameter Identification	Penetrameter Thickness (inches)	Essential hole
Up to 0.375	7	.007	4T
Over 0.375 to 0.50	10	.010	4T
Over 0.50 to 0.625	12	.012	4T
Over 0.625 to 0.75	15	.015	4T
Over 0.75 to 0.875	17	.017	2T
Over 0.875 to 1.00	20	.020	2T
Over 1.00 to 1.25	25	.025	2T
Over 1.25 to 1.50	30	.030	2T
Over 1.50 to 2.00	35	.035	2T
Over 2.00 to 2.50	40	.040	2T
Over 2.50 to 3.00	45	.045	2T
Over 3.00 to 4.00	50	.050	2T
Over 4.00 to 6.00	60	.060	2T

*Fracture Critical Member or Component

911. ULTRASONIC TESTING

All Complete Joint Penetration Weld (CJP) in tension and 25% of all CJP weld or 25% of the total CJP weld on the piece (minimum of one complete joint) in compression joints, where the piece contains Fracture Critical welds, shall be ultrasonic tested (UT) in accordance with Section 17. The cost of these tests shall be included in the price bid for the structural steel.

The DCES reserves the right to ultrasonic test other welded joints. Such testing, when performed, shall be done by State representatives.

Discontinuities found in fracture critical members shall be recorded on the ultrasonic test report when their Indication Rating is +14 db or less.

912. MAGNETIC PARTICLE INSPECTION

When magnetic particle inspection of FCM's or components of FCM's is required, magnetization of the part to be inspected shall be accomplished using a yoke unless otherwise ordered by the DCES. All other provisions of Section 18, Magnetic Particle Inspection, shall apply.

913. DYE PENETRANT INSPECTION

Dye penetrant inspection of FCM's or components of FCM's, when required, shall be performed in accordance with Section 19, Dye Penetrant Inspection.

914. VISUAL INSPECTION

A careful visual inspection of all completed work, including an inch by inch detailed visual inspection of all welds, shall be performed by Quality Control and Quality Assurance inspectors to insure conformance with the Contract documents. A portable light source and magnifying glass shall be used as necessary to insure the accuracy of visual inspection.

SECTION 10 BOLTING

1000. GENERAL

This section covers NYSDOT's requirements for storage, handling, testing, installation, and inspection of bolted connections. Reference is made to the Research Council on Structural Connections (RCSC) document "Specifications for Structural Joints Using High-Strength Bolts", which is available online at:

<http://www.boltcouncil.org/files/2014RCSCSpecification-2014.pdf>

It is intended that this document be consistent with the RCSC specification, with NYSDOT-specific requirements and limitations added. In the event of a conflict, this document governs.

1001. HIGH STRENGTH BOLTS, NUTS & WASHERS - MATERIAL REQUIREMENTS

1001.1 General. High strength bolts shall conform to the provisions of the current ASTM Standard Specification for High-Strength Structural Bolts: F3125, Grade A325 or F3125, Grade A490. Use of Grade A490 bolts requires D.C.E.S. approval.

All bolts, nuts and washers shall be marked by the manufacturer as described in the applicable ASTM Standard Specification and in Figure 1001.1.

Rotational capacity tests are required for each project and shall be performed on all plain or galvanized (after galvanizing) bolt, nut, and washer assemblies. Each combination of bolt production lot, nut lot, and washer lot, shall be tested as an assembly, in accordance with FHWA Appendix A1-325. (See Appendix L.)

1001.2 New Structure Applications:

1001.2.1 Non-Weathering Steel Applications (Shop Painted) : The Contractor has the option of using either plain or hot dipped galvanized bolts, nuts and washers for steel applications that use organic zinc-rich primer paint systems. The option selected shall be used for all bolted connections on the structure, both shop and field installations. The option selected shall be clearly indicated on the shop and erection drawings.

Bolts shall be ASTM F3125, Grade A325, Type 1 (plain or hot dipped galvanized)

Nuts shall be A563, Grade DH (plain or hot dipped galvanized); or ASTM A194, Grade 2H (plain or hot dipped galvanized)

Washers shall be ASTM F436, Type 1 (plain or hot dipped galvanized)

1001.2.2 Weathering Steel Applications (Painted or Unpainted) : Bolts, nuts and washers to be used in weathering steel applications shall be corrosion resistant and shall display proper markings to indicate they are manufactured from weathering steel.

Bolts shall be Grade A325 Type 3 (plain) or Grade A490, Type 3 (plain)

Nuts shall be A563, Grade DH3 (plain)

Washers shall be F436 Type 3 (plain)

1001.2.3 Galvanized Steel Applications: Galvanized fasteners shall be used for all galvanized or metalized steel applications.

Bolts shall be Grade A325, (Type 1) (hot dipped galvanized)

Nuts shall be A563, Grade DH (hot dipped galvanized); or A194, Grade 2H (hot dipped galvanized)

Washers shall be F436 (hot dipped galvanized)

1001.3 Bridge Rehabilitation Applications

1001.3.1 Existing Non-Weathering Steel Structures.

Bolts shall be Grade A325, (Type 1) (plain)

Nuts shall be A563 Grade DH (plain) or A194 Grade 2H (plain)

Washers shall be F436, Type 1 (plain)

1001.3.2 Existing Weathering Steel Structures. See Section 1001.2.2.

1002. STORAGE AND HANDLING

Bolts shall be stored in the manufacturer's sealed containers at a location protected from the elements until ready for use. Containers must remain sealed until the beginning of the work shift. The number of containers opened and bolts removed shall be limited to the number needed to complete the bolting work for that particular shift. Upon opening the containers, the bolts shall be inspected for presence of lubricant, and be relubricated if they dried out during storage. Any bolts showing signs of corrosion shall be rejected and removed from the worksite. Wire brushing to remove rust will not be acceptable.

Any bolts that are left over at the end of the shift and that are not wet may be returned to the container, which will then be properly sealed and returned to a protected location. Unused bolts that are wet from rain or snow at the end of the shift must be properly dried and relubricated before being returned to storage.

1003. SAMPLING AND TESTING

Bolts to be used for primary member connections shall be sampled and submitted to the Department Laboratory, for testing, to ensure that they meet the physical, mechanical and chemical requirements of the specifications, and that the minimum tension values in Table 1003.1 can be attained. They shall also be inspected for proper markings prior to sampling and during the course of the work. Any lot containing improperly marked bolts, nuts and/or washers shall be rejected.

Two sample bolts and nuts shall be selected at random from each manufacturer's control lot. When Type 3 fasteners are required, two washers shall also be selected. Samples shall be submitted to the Department Laboratory for testing with a completed copy of Form BR 240. One Form BR 240 shall be submitted for each manufacturer's control lot. A manufacturer's control lot is defined as all fasteners of the same grade and size that are produced under the same production controls. Before sampling the fasteners, the Inspector shall examine the certified copies of test reports provided by the manufacturer, to ensure that the bolts, nuts, and washers were manufactured to specification requirements and are of domestic origin. Box 10 of the Form BR240 shall state "Melted and Manufactured in the USA." The manufacturer's control lot numbers on the test reports must match the lot numbers marked on the shipping containers. If these criteria are not met, the lot in question shall be rejected.

For lots containing less than 20 bolts, field examination in lieu of sampling is acceptable. Bolts shall be inspected prior to installation to determine that they have no unacceptable workmanship defects such as head bursts (open breaks in the flats or corners of the threads), seams, cracks, burned heads, etc., and that they do

not have incomplete or improper markings. Bolts having visible defects in material and workmanship or which are improperly marked shall be rejected.

If Direct Tension Indicators with dye release (DTIs) are to be used, a minimum of three from each production lot and bolt size shall be tested. Each test assembly shall consist of a bolt, a hardened washer under the head, and a DTI with the protrusions bearing against the washer. The bolt shall be turned in a Skidmore device until dye is released from all protrusions. The tension at which this occurs shall be recorded for each assembly. If any of the tension values are below the minimum values shown in Table 1003.1, the lot is to be rejected.

1004. INSTALLATION

Unless stated otherwise on the plans, all joints on highway bridges, railroad bridges, and overhead sign structures will be treated as slip-critical. Therefore, installation by calibrated wrench method, or use of twist-off bolts, is prohibited, since those methods cannot guarantee that the necessary tightness for slip-critical performance can be attained. The length of the bolts shall be such that the end of the bolt is flush or protrudes slightly above the nut face upon completion of the installation. [Any installation with a less than full engagement of the threads will be rejected.](#)

For connections with standard sized holes, washers shall be placed under the turned element. Washers shall be placed under both the head and the nut if any of the following apply:

- a) Oversized holes in one or both outer plies.
- b) Replacement of existing bolts or rivets.
- c) Connections between new and existing steel.
- d) Connections prepared by drilling from solid in the field.
- e) Use of Grade A490 bolts with base material yield stress below 40 ksi.

When the outer face of the joint has a slope that is greater than 1:20 with respect to a plane that is normal to the bolt axis, an ASTM F436 beveled washer shall be used to compensate for the lack of parallelism.

For horizontal installations, the bolt shall be installed with the nut shielded from the weather whenever feasible. For vertical installations, the bolt heads shall be up.

1004.1 Installation by Turn-of-nut method

Turn-of-nut installation is the preferred and default method unless field conditions preclude its use. Proper snugging, match-marking and final rotation procedures as outlined in the RCSC specifications and the following shall be employed.

Snug tight is the condition that exists when all of the plies in a connection have been pulled into firm contact by the bolts in the joint and all of the bolts in the joint have been tightened sufficiently to prevent the removal of the nuts without the use of a wrench. Snugging shall begin at the most rigid (or central) location of the joint and systematically proceed outward. The amount of torque needed to snug each bolt corresponds to the maximum effort that an ironworker with a spud wrench can exert, or approximately 150 ft-lbs. At all girder splices or other joints with more than 20 bolts, the 4 bolts that were snugged first will be checked for the snug-tight condition upon completion of initial snugging for the entire connection. If any bolts are loose, then the snugging operation will be repeated for all of the bolts in the joint.

After satisfactory completion of the snugging operation, all bolt shanks and nuts must be match-marked before any final rotation takes place, regardless of which element (head or nut) is turned. After proper match-marking, final rotation shall proceed, starting at the most rigid part of the joint and proceeding systematically outward. The amount of rotation shall correspond to Table 1004.1. If the head is the turned element, washers should be lubricated for ease of installation.

For bolt lengths greater than 12 diameters, at least three fastener assemblies shall be tested in a load indicating device (“Skidmore”), using the following procedure.

1. Tighten the assembly in the Skidmore until $25\% \pm 5\%$ of the required bolt tension in Table 1003.1 is attained.
2. Match-mark the nut and the bolt.
3. Perform final tightening until 1.05 to 1.1 times the required bolt tension is achieved, and record the results. The assembly that needed the most rotation to attain the proper bolt tension will be the governing case for the established required rotation.

1004.2 Installation using Direct Tension Indicators (DTIs)

The contractor may, with DCES approval, use dye release DTIs meeting the requirements of ASTM F959. DTI protrusions must bear against a hardened element such as a bolt head, nut, or washer. If the DTI is placed under the turned element, there shall be a hardened washer between the DTI and the turned element. If the DTI is used over an oversized hole, there shall also be a hardened washer between the DTI and the plate.

The snug tight condition will be achieved using the same methodology as for turn of nut installation. Similarly, for all girder splices or other joints with more than 20 bolts, the 4 bolts that were snugged first will be checked for the snug-tight condition upon completion of initial snugging for the entire connection. If any bolts are loose, then the snugging operation will be repeated for all of the bolts in the joint. After satisfactory completion of the snugging operation, final rotation shall proceed, starting at the most rigid part of the joint and proceeding systematically outward.

The state reserves the right to request that up to 5% of the bolts in a DTI connection be match-marked after snugging. The contractor shall inform the EIC as to the fraction of a turn that was performed to achieve full dye release.

1004.3 Bolt Reuse

For applications where a newly installed component needs to be removed and reinstalled, uncoated Grade A325 bolts may be reused **once** provided the nut can be manually engaged along the entire threaded length of the bolt. Galvanized A325 and any Grade A490 bolts may not be reused and must be discarded.

1005. INSPECTION

1005.1 Inspection of turn-of-nut installations

For turn-of-nut installation, the preferred inspection method is direct inspector observation of snug-tightening, match marking, and final tightening. Match marking shall consist of marking the protruding end of the bolt and the nut. Marking the nut and the plate is not acceptable. Any bolt installations that are not properly match-marked after snug-tightening and prior to final tightening shall be rejected.

Alternatively, bolt tension may be verified using an inspection torque wrench provided and operated by the Contractor. The inspection torque shall be determined daily by tightening a minimum of three bolts of each length and diameter in a calibration device capable of indicating bolt tension. An ASTM F436 washer shall be placed under the part being turned. Each of the bolts shall be tightened in the calibration device to the minimum required tension as listed in Table 1003.1. The turned element shall then be rotated an additional 5 degrees, and the corresponding torque shall be measured. The average value for the bolts tested shall be taken as the **minimum job inspection torque (MJIT)**.

A minimum of 10% of the bolts (at least two) per connection will be selected at random for testing. The MJIT will be applied to the bolts selected. If any are loose, they shall be tightened and reinspected. **All remaining bolts in the connection will then need to be checked.**

1005.2 Inspection of DTI installations

DTI installations will be inspected by visually checking for proper installation and observing the snugging operation. If any DTIs show more than a nominal amount of dye release after snugging, they shall be replaced. After snugging, final tightening will be observed and the final installation shall be visually examined for complete dye release for all DTIs.

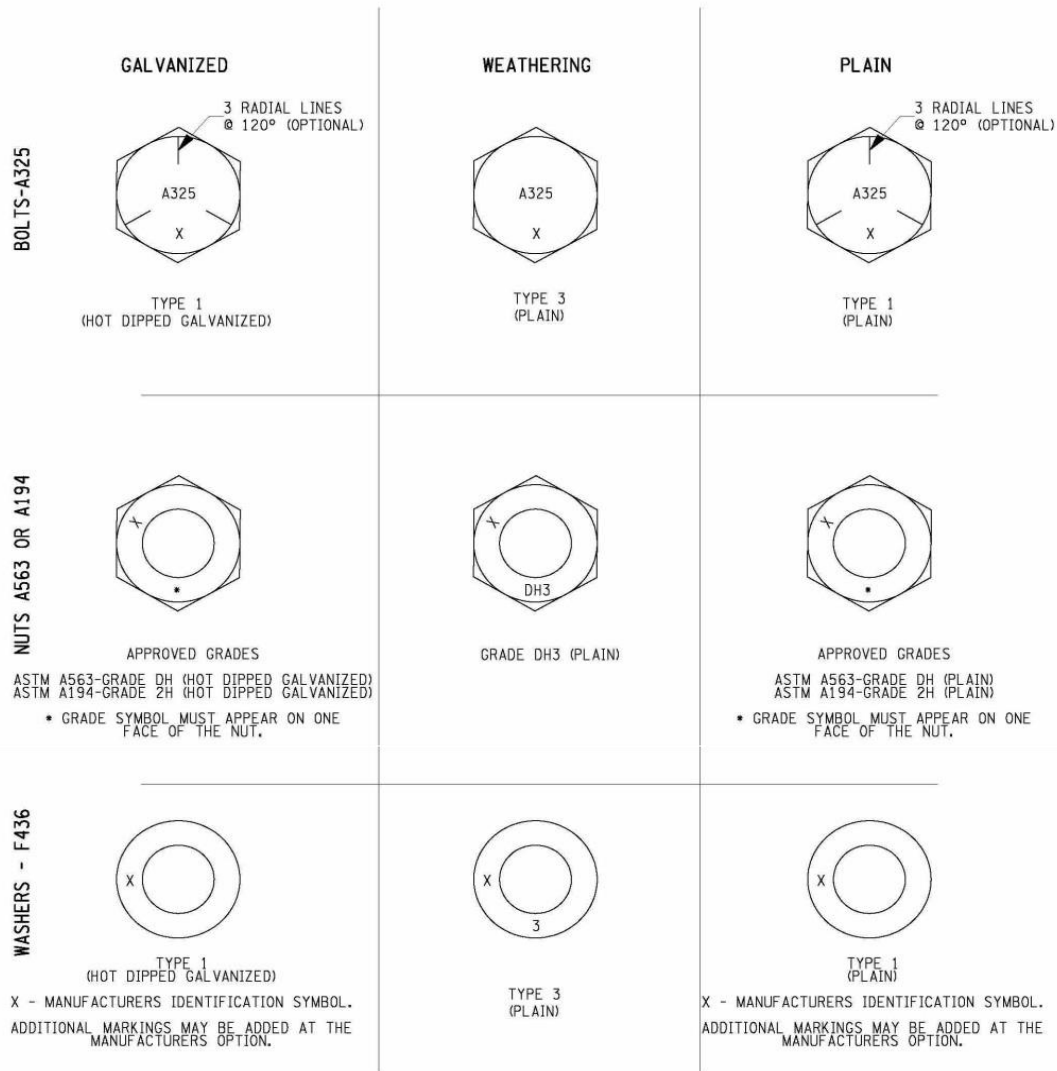

FIGURE 1001.1 – REQUIRED MARKING FOR HIGH STRENGTH FASTENERS

TABLE 1003.1 – MINIMUM BOLT TENSION

Bolt Diameter (inches)	Minimum Bolt Tension ^a in Thousands of Pounds (kips) A325 Bolts
1/2	12
5/8	19
3/4	28
7/8	39
1	51
1-1/8	64
1-1/4	81
1-3/8	97
1-1/2	118

^a Equal to 70 percent of specified minimum tensile strengths of bolts, rounded off to the nearest kip.

TABLE 1004.1 - NUT ROTATION FROM SNUG TIGHT CONDITION

Bolt Length (as measured from underside of head to extreme end of point)	Disposition of Outer Faces of Bolted Parts		
	Both faces normal to bolt axis	One face normal to bolt Axis and other face Sloped not more than 1:20 (bevel washer not used)	Both faces sloped not More than 1:20 from normal to bolt axis (bevel washer not used)
Up to and including 4 diameters	1/3 turn	1/2 turn	2/3 turn
Over 4 diameters but Not exceeding 8 Diameters	1/2 turn	2/3 turn	5/6 turn
Over 8 diameters but Not exceeding 12 diameters	2/3 turn	5/6 turn	1 turn

Nut rotation is relative to bolt, regardless of the element (nut or bolt) being turned. For bolts installed by 1/2 turn and less, the tolerance should be plus or minus 30°. For bolts installed by 2/3 turn and more, the tolerance should be plus or minus 45°.

For bolts lengths exceeding 12 diameters the required rotation must be determined by actual test in a suitable tension device simulating the actual conditions.

SECTION 11 SHOP ASSEMBLY

1101. ASSEMBLY OF SHOP WELDED CONNECTIONS

1101.1 Welded Joint Fit-up. Parts to be joined by fillet welds shall be brought into as close contact as practical. Except for the provisions of Section 12, the maximum gap between parts being joined shall be $\frac{3}{16}$ inch [5 mm] unless a modified welding procedure is approved by the DCES. If the separation is greater than $\frac{1}{16}$ inch [2mm], the weld size shall be increased by the amount of the separation or the Contractor shall demonstrate that the required throat thickness has been obtained.

The separation between faying surfaces of lap joints and of butt welds landing on a backing shall not exceed $\frac{1}{16}$ inch [2 mm]. The use of fillers is prohibited. Backing for skewed joints may require shaping, bending, or beveling to maintain this requirement.

Abutting parts to be joined by groove welds shall be carefully aligned. Where the parts are effectively restrained against bending due to eccentricity in alignment, an offset not exceeding 10 percent of the thickness of the thinner part joined, but in no case more than $\frac{1}{8}$ inch [3 mm], may be permitted as a departure from the theoretical alignment. In correcting misalignment in such cases, the parts shall not be drawn in to a greater slope than 1 in 24. Measurement of offset shall be based upon the center line of parts unless otherwise shown on the approved drawings.

Members to be welded shall be brought into correct alignment and held in position by bolts, clamps, wedges, guy lines, struts, other suitable devices or by tack welds until welding has been completed. Tack welding, when permitted shall conform to the requirements of this manual. The use of jigs and fixtures is recommended where practical. Suitable allowances shall be made for warpage and shrinkage.

Dimensions of the cross section of groove welded joints which vary from those shown on the detail drawings by more than the tolerances shown in AWS D1.5 Section 2 and modified by the SCM Section 7A shall be referred to the DCES for approval or correction.

1101.2 Assembly of Stiffeners. Intermediate stiffeners and connection plates shall be sniped at the corners and welded to the web and both flanges as detailed on the contract plans. The fillet welds connecting the stiffener or connection plate to the web shall be started at the end of the stiffener that is adjacent to the tension flange and progress toward the compression flange. At least 90 percent of the fillet welds shall extend to within $\frac{1}{4}$ inch [6 mm] of all sniped corners. The remaining percentage must start or stop within $\frac{1}{2}$ inch [12 mm] of the snipe. Care shall be taken to prevent the stiffener welds from intersecting the continuous flange to web welds. The maximum possible clearance between intersecting welds is desired. All fillet welds must have full throat and no unfilled craters at the beginning and end of the weld. Localized undercut of the stiffener at the point where the welding machine is started or stopped shall not require repair unless severe in the opinion of the Inspector.

Before welding, there shall be no gap between the web and the intermediate stiffeners, bearing stiffeners, or connection plates in excess of $\frac{3}{32}$ inch [2.4 mm].

Intermediate stiffeners and connection plates may be cut $\frac{1}{8}$ inch [3 mm] short and then assembled with the stiffener welded to both flanges. The weld size at the compression flange shall be increased to include the gap as required by Section 1101.1. Stiffeners shall not be driven in place with sufficient force to distort the flange, web or stiffener.

Tack welds used during stiffener assembly shall begin at least 3 inches [75 mm] from the snipe of the stiffener and shall have a minimum length of 1½ inch [38 mm]. This provision is made to prevent the starting and stopping of weld passes on tack welds. All tack welds shall be completely remelted and incorporated into the final weld.

1101.3 Attachment of Bearing Assemblies. At fixed bearing locations only, sole plates or bearing assemblies may be tack welded to the structural steel in the shop to facilitate shipment.

1102. SHOP ASSEMBLY OF FIELD WELDED CONNECTIONS

The Contractor shall be responsible for the proper preparation of groove joints to be welded in the field. The joints shall be prepared and assembled in the shop to insure that proper joint alignment and fit up is present at each joint when the correct camber is in the assembled pieces. The Contractor may, at its option, eliminate all shop assembly and joint preparation for field welding provided there is sufficient extra material at each joint to provide for machine thermal cutting or air carbon arc gouging of the joint preparation after assembly on the ground prior to erection at the site or assembly in the erected position under the proper conditions of support to provide for camber. All provisions of this manual concerning joint preparation, welding and inspection, shall apply. The members shall be free from twists, bends or other deformations.

1103. SHOP ASSEMBLY OF BOLTED CONNECTIONS

1103.1 General. Bolted parts shall fit solidly together when assembled and shall not be separated by gaskets or any other compressible material. Joint contact surfaces of primary stress carrying members shall be cleaned as described in Section 13. Other joint contact surfaces and the areas adjacent to the bolt holes shall be free of all scale except tight mill scale, burrs, dirt, paint, and other foreign material that may prevent solid seating of the parts.

Wire brushing is no longer recommended for galvanized faying surfaces.

Surfaces of metal to be in contact when assembled may be painted per Section 1303. Temporary protective coatings will be approved if completely removed before final assembly.

The component parts shall be assembled, drift pinned to prevent lateral movement, and firmly bolted to draw the parts into close contact before reaming or drilling is begun. Assembled parts shall be taken apart if necessary for the removal of cutting oil, burrs and shavings produced by the reaming or drilling operation.

Members shall be free from twists, bends or other deformations. Careful measurements shall be taken while the pieces are in assembly and before any reaming or drilling is performed to insure that the assembly conforms to the dimensions shown on the approved shop drawings within the dimensional tolerances described in Section 12.

Pieces to be connected by rivets or bolts shall not be subject to any welding unless such welding is shown on the plans or approved by the DCES.

1103.2 Support of Members During Assembly. All girders and beams are to be assembled in their cambered (no load) condition. When members are assembled, regardless of web orientation, they shall be supported at intervals of 20 ft. [6 m], or 20% of the span length, whichever is less. Curved girders with a horizontal radius less than 1000 feet [300 m] shall be shop assembled with their webs vertical. Trusses are to be assembled in their fully cambered (no load) position unless otherwise indicated in the contract documents. Trusses shall be supported during assembly at each panel point.

1103.3 Minimum Assembly & Hole Preparation Requirements

1103.3.1 Splices in Simply Supported Stringers and Girders

Assembly: Work shall be done with the full length of member assembled unless otherwise approved by the DCES.

Hole preparation: Holes in splices shall be: RA, DA, DT, CNC-MDT, with all connecting parts assembled, or CNC (DCES approved QC and verification plan required).

1103.3.2 Splices in Continuous Stringers and Girders

Assembly: Full or progressive component assembly as defined in Section 1103.4.1 or 1103.4.2.

Hole preparation: Holes in primary material splices shall be: RA, DA, DT, CNC-MDT, with all connecting parts assembled, or CNC (DCES approved QC and verification plan required).

1103.3.3 Connections in Railroad Thru Girders

Assembly: Special complete structure assembly as defined in Section 1103.4.5. Girders, floorbeams and knee braces shall be put into assembly unless specified otherwise in the Contract Plans.

Hole preparation: Holes in connections shall be: RA, DA, DT, CNC-MDT, with all connecting parts assembled; or CNC with 100% check fit & assembly.

1103.3.4 Connections in Trusses

Assembly: Full truss, progressive truss, or special complete structure assembly as in Sections 1103.4.3 or 1103.4.4. Bottom chords and floorbeams shall be put into assembly.

Hole preparation: Holes in primary material splices shall be: RA, DA, DT, CNC-MDT, with all connecting parts assembled.

1103.3.5 Splices and Connections in Arches

Assembly: Full, progressive or special complete structure assembly as in Sections 1103.4.1, 1103.4.2, or 1103.4.5. Floorbeams and arch ribs shall be put into assembly.

Column to arch connections shall be put into assembly and shall meet the requirements of section 1208, "Bearing at Points of Loading."

Hole preparation: Holes in primary material splices shall be: RA, DA, DT, CNC-MDT, with all connecting parts assembled.

1103.3.6 Splices and Connections in Viaduct Structures

Assembly: Transverse girders and continuous longitudinal stringers shall be put into assembly.

Hole preparation: Holes in primary material splices shall be: RA, DA, DT, CNC-MDT, with all connecting parts assembled, or CNC (when approved by DCES).

1103.3.7 Splices and Connections in Precision Structures (Bascule, Lift, Swing, and Suspension Bridges)

Assembly: Either "Special Complete Structure Assembly" for the entire structure, such as new truss lift bridge; or complete structure assembly of critical components, as in the bascule leafs of a lift bridge.

Hole preparation: Holes in primary material splices shall be: RA, DA, DT, CNC-MDT, with all connecting parts assembled.

1103.4 Assembly Requirements. All structural components shall be assembled in the shop with milled ends of compression members in full bearing unless otherwise specified, and then shall have their holes reamed or drilled from the solid with all connecting parts assembled.

1103.4.1 Full Component Assembly. Full component assembly shall consist of assembling all members of: each truss, arch rib, bent, tower face, continuous beam line, plate girder, or rigid frame, at one time. When stringers and girders are continuous because of their attachment to intermediate transverse structural steel supporting beams or girders regardless of cross section, these intermediate transverse beams or girders shall be part of the assembly.

1103.4.2 Progressive Component Assembly. In lieu of full component assembly, the fabricator may opt to perform progressive assembly on structural components with multiple members. Progressive assembly differs from full assembly in that members previously placed in assembly may be removed as other components are added. Assembly shall start at one end, and there shall be at least 150' of component length or three members in assembly at all times.

For example, take a girder length of 5 members labeled A through E, each being 80' long. An acceptable progressive assembly sequence would be A-B-C, remove A, and add D to get to B-C-D, then remove B and add E to get to C-D-E. To go from three assembly steps to two, it would be acceptable to go from sequence A-B-C-D to C-D-E. It is **not** acceptable to go from sequence A-B-C to C-D-E.

Progressive beam and girder assembly shall be done in accordance with the approved shop drawings; any change to the progression shall be clearly identified on revised shop assembly drawings submitted as per SCM section 202.8 Revisions.

Progressive: truss, arch rib, bent, tower face, and rigid frame assembly requires DCES approval.

The method of assembly must be clearly shown on the SA Shop Drawings.

1103.4.3 Full Chord Assembly. (Requires DCES Approval) Full chord assembly shall consist of assembling the full length of each chord of each truss or each leg of each bent or tower with geometric angles at the joints and then reaming, (RA); or drilling from the solid (DA); the field connection holes while the members are assembled. When this method of assembly is permitted, the Contractor shall have the option of reaming or drilling web members while assembled to the chords at proper geometric angles or reaming or drilling web members with properly located steel templates.

1103.4.4 Progressive Chord Assembly. (Requires DCES Approval) Progressive chord assembly may be employed at the Contractor's option when permitted. This method of assembly shall be the same as the described for full chord assembly except that the number of pieces and minimum assembled length specified for progressive truss and girder assembly shall apply.

1103.4.5 Special Complete Structure Assembly. Special complete structure assembly shall consist of assembling the entire structure including the floor system. This method of assembly will not be required unless specifically called for in the Contract Documents.

1103.5 Reaming to a Template. When reaming to a template is permitted, the templates shall be steel, ¼ inch [6 mm] minimum thickness, with hardened steel bushings. The template shall be accurately positioned from the working lines marked on the piece and inscribed on the template.

The finished holes shall meet the requirements of the Contract Documents and be aligned to insure proper camber in the completed assembly.

1103.6 Computer Numerically Controlled (CNC) Drilling. Structures may be fabricated unassembled with their individual components drilled using numerically controlled equipment, provided the Contractor's quality control and verification procedures are approved by the DCES, with the following exceptions:

- CNC shall not be used for splices in horizontally curved structures with radii ≤ 1200 feet [365 m]
- CNC shall not be used when multiple plies are framed in multiple directions.
- CNC shall not be used in framed connections with different web thicknesses.
- CNC shall not be used in framed beam connections with skewed bent plates.

Approval of the procedure will not relieve the Contractor of the responsibility to provide accurately matching holes in properly aligned pieces when assembled.

Numerically controlled drilling shall not create a need for fills to produce accurate fit.

All other connections which are drilled with numerically controlled equipment and are not shop assembled shall be checked for entering and fit of pieces by careful shop measurements made by the Contractor. The Contractor shall be responsible for the dimensions and fit of all pieces, whether shop assembled or not.

1103.6.1 Quality Control and Verification Measures of Line Elements Fabricated Using CNC:

A minimum of 40 percent of holes in the first 25 percent of the connections fabricated shall be shop assembled to verify the quality of the holes, the accuracy of alignment and fit of mating pieces. If satisfactory work is verified by accurately checking the first quarter of the work drilled, hole alignment verification may be reduced to a minimum of 10 percent of the remaining connections, selected at random.

If the holes are drilled CNC in the plates before piece fabrication, then overall camber and sweep (where applicable) shall be verified prior to shipment through full or progressive assembly in accordance with §§1103.4.1 or 1103.4.2. Connections for which hole alignment is not checked shall be pinned. If the holes are drilled CNC after piece fabrication, which includes stiffeners and connection plates, and all pieces are properly secured before drilling, then the assembly requirements may be modified as follows.

Where multiple girder lines have the same required camber, one girder line to be selected by NYSDOT or its designated inspector will require full or progressive assembly. This will be the proof girder. If the cambers for the proof girder meet tolerance as per Section 12, the remaining girders will not require assembly **provided** that their piece cambers are within 1/8" of the corresponding piece cambers of the proof girder. Check locations will be at piece quarter points, or span tenth points, whichever is less. If any location along a piece fails to meet the 1/8" match requirement, then the entire girder line shall be assembled full or progressive. For galvanized bridges, piece cambers shall be checked after galvanization.

If the proof girder does not meet tolerance, then the camber must be corrected to acceptable as per Section 15, and all remaining girders on the bridge shall be assembled full or progressive.

Application of this modified assembly procedure for CNC drilled components does not absolve the contractor from the responsibility of meeting all applicable tolerances in the field.

1103.6.2 Quality Control and Verification Measures of Multidimensional Framing Fabricated Using CNC:

Two options are available to verify the quality of holes, and the accuracy of alignment and fit of mating pieces:

- Option 1** Check Fit 100% of the structural connections with pins during full structure assembly.

Option 2 Provide a global coordinate reference system on the shop drawings, and follow the check fit procedure listed below.

The required percentage of connections to be checked using full size pins shall be as follows:

- Type 1 (For simple shear framed beam connections):
40% of the holes in 25% of the connections to be check fit.
- Type 2 (For moment connections, with framing in two directions):
40% of the holes in 50% of the connections to be check fit.
- Type 3 (For moment connections, with framing in three directions):
40% of the holes in 75% of the connections to be check fit.

Step wise reduction in pin fitting:

Only after successful fit is achieved, will a reduced percentage be allowed for the remainder of connections within an assembly. For example, if 75% of the Type -3- connections within a unit are successfully check fit, the NYSDOT shop inspector can reduce the percentage to 50% of the connections within the next unit of the assembly.

Coordinate check. Shop Inspector shall verify x, y and z coordinates during lay down.

1103.7 Abutting Joints. Bolted joints and splices in main stress carrying members shall have their abutting parts carefully aligned. Whenever joints are designed with an opening of less than $\frac{3}{8}$ inch [10 mm] between pieces to be joined, parts over $\frac{1}{2}$ inch [12 mm] in thickness shall have their surfaces parallel and shall have an offset no greater than $\frac{1}{16}$ inch [2 mm] from theoretical alignment prior to bolting up. For parts less than $\frac{1}{2}$ inch [12 mm] in thickness, the above offset may be increased to $\frac{1}{8}$ inch [3 mm] maximum. After all bolts are tightened to the specified tension, the parts shall be in contact so that the joint will develop the design friction capability and will prevent exposure of the bolt stem to the atmosphere.

If the design is based on transmitting all stress through the fasteners, the joints may be detailed open $\frac{1}{4}$ inch [6 mm] maximum unless otherwise provided in the Contract Documents. Joints designed with a nominal $\frac{1}{4}$ inch [6 mm] opening may be assembled with an accuracy of $\pm \frac{1}{8}$ inch [3 mm], i.e., $\frac{1}{8}$ inch [3 mm] minimum and $\frac{3}{8}$ inch [9 mm] maximum.

1103.8 End Connection Angles. End connection angles of floor beams and stringers shall be flush with each other and accurately set as to position and length of member. In general, end connection angles shall not be finished unless required by the Contract Documents. However, faulty assembling and connecting may be cause for requiring them to be milled, in which case their thickness shall not be reduced by more than $\frac{1}{16}$ inch [2 mm], nor shall their fastener bearing value be reduced below design requirements.

1103.9 Drifting of Holes. Any drift pinning done during assembly shall be only the minimum necessary to bring the parts into position, and not sufficient to enlarge the holes or distort the metal.

1103.10 Match-Marking. Connecting parts assembled in the shop for the purpose of reaming, drilling holes in field connections, as well as CNC Match Drill Templates (CNC-MDT) connections, shall be match-marked. A diagram showing the match marks shall be furnished to the Engineer, unless the connecting parts are shipped attached to the piece..

1103.11 Field Assembly in Lieu of Shop Assembly. The State will approve the elimination of shop assembly of continuous stringers and girders together with their attachments to transverse supporting beams provided the Contractor will perform exactly the same operation during field erection, i.e., ream

assembled or drill from the solid, and assume all additional costs incurred by doing this work in the field.

1104. ALIGNMENT OF MEMBERS DURING SHOP ASSEMBLY.

All steel required to be shop assembled for line camber and/or profile verification, reaming, drilling from the solid, or weld joint preparation shall be aligned so that the control points (bearing locations or support points) are within $\pm \frac{1}{8}$ inch [3 mm] from the locations shown on the approved shop drawings. This tolerance shall apply to the X, Y, and Z coordinates, i.e., in all three dimensions.

SECTION 12
DIMENSIONAL TOLERANCES FOR FABRICATED MEMBERS

1201. GENERAL

The provisions of this Section shall apply to all members, independent of cross section, whether straight or curved. Members heat-curved under the provisions of Section 15, Heat-Curving, Cambering and Straightening shall meet the dimensional tolerances of this section. Before welding, dimensions of shapes and plates shall conform to the tolerances described in ASTM Designation A6. After the start of any fabrication and after welding has been completed, all members shall conform to the dimensional tolerances of these specifications. All measurements shall be compared to the dimensions shown on the approved shop drawings.

1202. DEVIATION FROM DETAILED LENGTH

Members with ends milled for bearing and members with faced-end convection angles may deviate from the detailed length by $\pm [1/32 \text{ inch [1 mm]}]$ maximum. All other members may vary from the detailed length by $\pm [1/4 \text{ inch [6 mm]}]$ maximum, unless otherwise approved by the DCES.

1203. DEVIATION FROM DETAILED WIDTH.

The width of members (flanges, coverplates, etc.) may deviate from the detailed width by $\pm 1/8 \text{ inch [3 mm]}$. This does not apply to the areas allowed by Section 601 for ground gouge repairs.

1204. DEVIATION FROM SPECIFIED DEPTH

The maximum deviation from the specified depth of welded beams and girders, measured at the web centerline, shall not exceed the following:

For depths up to 36 inches, inclusive $\pm 1/8 \text{ inch}$
For depths over 36 inches to 72 inches, inclusive $\pm 3/16 \text{ inch}$
For depths over 72 inches $+ 5/16 \text{ inch, } -3/16 \text{ inch}$

1205. LOCATION OF WELDED BUTT JOINTS

Welded butt joints shall not be placed more than $1/2 \text{ inch}$ from the detailed location.

1206. INTERMEDIATE STIFFENERS

1206.1 Location. Intermediate stiffeners may vary $\pm 1/2 \text{ inch [12 mm]}$ from the detailed location.

1206.2 Deviation from Straightness and Fit of Intermediate Stiffeners. The deviation from straightness of intermediate stiffeners shall not exceed $1/2 \text{ inch}$ in the length of the stiffener. The edge of the stiffener that is welded to the web of the girder shall be straight and, when fit to the web, shall have no gaps in excess of $3/32 \text{ inch [2 mm]}$ between the web and the stiffener. Where tight fit of intermediate stiffeners is specified, a gap of up to $1/16 \text{ inch}$ between stiffener and flange is allowed.

1207. BEARING STIFFENERS

1207.1 Deviation from Straightness of Bearing Stiffeners. The out-of-straightness of bearing stiffeners shall not exceed $1/4 \text{ inch}$ for stiffeners up to 6 feet in length and $1/2 \text{ inch}$ for lengths over 6 feet.

The centerline of the attached stiffener shall lie within the dimensional boundaries of a perfectly straight stiffener of the same thickness. They shall fit to the web as described in Section 1206.2.

1207.2 Ends in Bearing. The bearing ends of bearing stiffeners shall be flush and square with the web and at least 10 percent of the area at the bearing end shall be in intimate contact with the flange. The remaining portion may have a gap not exceeding 0.040 inch.

1208. BEARING AT POINTS OF LOADING

The maximum gap between abutting parts at any bearing point shall be 0.040 inch. When mill to bear (MB) is specified at a point of bearing, the surfaces shall be plane and true within 0.010 inch.

1209. WARPAGE AND TILT OF FLANGES

The combined warpage and tilt of flanges of welded beams or girders shall be determined by measuring the offset at the toe of the flange from a line normal to the plane of the web, through the intersection of the centerline of web, with the outside surface of the flange plate. This offset shall not exceed 1/100 of the total width of the flange or ¼ inch, whichever is greater. This deviation does not apply to bearing areas at points of loading. At bearing points the flange shall be perpendicular to the web and shall be flat so that bearing will be achieved between abutting parts as required in Section 1208.

1210. WEB TO FLANGE OFFSET

The lateral deviation between centerline of web and centerline of flange of fabricated girders shall not exceed ¼ inch.

1211. DEVIATION FROM FLATNESS OF GIRDER WEBS

1211.1 Girders with Intermediate Stiffeners and/or Connection Plates. The maximum deviation from flatness of girder webs shall be determined by measuring offsets from a straight edge whose length is not less than the least dimension of any panel. The straight edge shall be placed in any position within the panel necessary to measure the maximum deviation of the web. A panel is defined as the web area bounded by flange plates or horizontal stiffeners and any two adjacent vertical stiffeners or connection plates, regardless of side to which attached.

The maximum deviation from web flatness shall be determined by applying the following formula to each panel:

$$\text{maximum deviation} = \frac{d}{100} \text{ where } d \text{ is the least panel dimension in inches.}$$

Table 1211.1 lists values obtained using the above formula.

TABLE 1211.1 - MAXIMUM DEVIATION FROM WEB FLATNESS FOR GIRDERS WITH INTERMEDIATE STIFFENERS AND/OR CONNECTION PLATES

Least Panel Dimension (in.)	12	18	25	31	37	44	50	56	62	69	75	81	87	94	100
Allowable Deviation (in.)	1/8	3/16	1/4	5/16	3/8	7/16	1/2	9/16	5/8	11/16	3/4	13/16	7/8	15/16	1

1211.2 Girders With No Full-Depth Web Attachments. The maximum deviation from web flatness of shafts (girders with no full-depth web attachments which may stiffen the web) shall be determined by applying the following formula:

$$\text{maximum deviation} = \frac{d}{150} \text{ where } d \text{ is the depth of the web in inches.}$$

Table 1211.2 lists values obtained using the above formula.

TABLE 1211.2 - MAXIMUM DEVIATION FROM WEB FLATNESS FOR GIRDERS WITHOUT INTERMEDIATE STIFFENERS, CONNECTION PLATES OR OTHER FULL DEPTH ATTACHMENTS THAT MAY STIFFEN THE WEB.

Depth of Web (in.)	19	28	37	47	56	66	75	84	94	103	113	122	131	141	150
Allowable Deviation (in.)	1/8	3/16	1/4	5/16	3/8	7/16	1/2	9/16	5/8	11/16	3/4	13/16	7/8	15/16	1

1211.3 Web Flatness at Bolted Ends. Webs of plate girders that are shop assembled and have shrinkage distortion at the bolted end in excess of the flatness requirements specified may be shipped to the project site for erection provided shop assembly has demonstrated that the splice material will straighten the web to acceptable tolerances when less than 25 percent of the required splice bolts were installed.

1212. DEVIATION FROM STRAIGHTNESS OF WELDED COLUMNS

a) Length of 45 feet and under:

$$\frac{1}{8} \text{ inch} \times \frac{\text{No. of feet of test length}}{10}, \text{ but not over } \frac{3}{8} \text{ inch}$$

b) Lengths over 45 feet:

$$\frac{3}{8} \text{ inch} + \frac{1}{8} \text{ inch} \times \frac{\text{No. of feet of total length} - 45}{10}$$

The above deviations do not apply to guide columns in vertical lift bridges. Guide columns shall be straight within the limits specified on the Plans or ordered by the DCES.

1213. DEVIATION FROM HORIZONTAL ALIGNMENT

Deviation from specified horizontal alignment (sweep) in curved beams and girders and deviation from straightness in beams and girders with no specified sweep shall not exceed the following:

a) $\pm \frac{1}{8} \text{ inch} \times \frac{\text{Total no. of feet between supports}}{10}$,

or

b) $\pm \frac{1}{8} \text{ inch} \times \frac{\text{No. of feet from the nearest end}}{10}$

If the top and bottom flange deviations are on opposite sides of the theoretical centerline, the total deviation (top flange plus bottom flange) shall not exceed either of the values computed by a) or b) above.

This maximum deviation may only be used when the member has sufficient lateral flexibility to permit the attachment of diaphragms, cross frames, lateral bracing, etc., without damaging the structural member or its attachments.

1214. DEVIATION FROM SPECIFIED CAMBER

1214.1 General. Camber measurements shall be made in the shop prior to shipment and in the field after erection to insure conformance with the Contract documents.

All camber measurements in the shop shall be made by the Fabricator in the presence of the NYS QA inspector. The camber of each single erection piece, after fabrication, shall be in accordance with the approved shop drawing and submitted to the DCES for review. When shop assembly is required, full line camber measurements shall also be made on the assembled members in accordance with the approved shop drawing and the results submitted to the DCES for review prior to drill the splices.

Final camber measurements shall be made by the Contractor after erection. The Contractor shall notify the Engineer-In-Charge in advance so that camber measurements may be witnessed. After erection, each member shall have all of the specified camber, less the dead load deflection of the steel, within the tolerance specified herein.

When members do not conform to these requirements, either in the shop or in the field, the DCES may order camber correction by the heat-shrink process submitted for approval to the DCES in accordance with Section 15. Negative camber deficiencies are unacceptable and may only be corrected by heat-shrink procedures approved by the DCES. Camber deviations that cannot be corrected by the heat-shrink technique without adversely affecting the structural steel, in the opinion of the DCES, shall be cause for rejection and replacement of the steel at no cost to the State.

1214.2 Deviation from Specified Camber of Single Erection Pieces.

a) Stringers, girders and floorbeams:

- 1) at bearing locations $\pm \frac{1}{8}$ " (3 mm)
- 2) at midpoint -0, + $\frac{3}{4}$ inch [19 mm]
- 3) at intermediate points -0, + $\frac{1}{8}$ inch x $\frac{\text{No. of feet from nearest end}}{10}$ or + $\frac{3}{4}$ inch, whichever is less

Note: The fabricator may elect not to check piece camber for stringers, girders and floorbeams when span assembly for these pieces is performed. Span assembly shall meet the piece camber requirements shown above.

b) Truss chord, web members and built-up hanger members:

$$\pm \frac{1}{8} \text{ inch} \times \frac{\text{No. of feet of total length}}{10}, \text{ or } \frac{3}{8} \text{ inch, whichever is less}$$

c) Arch members and rigid frames:

$$\pm \frac{1}{8} \text{ inch} \times \frac{\text{No. of feet of total length}}{10}, \text{ or } \frac{3}{4} \text{ inch, whichever is less}$$

Measurements to verify conformance with the above requirements shall be made with the member lying on its side in the no-load condition or, when blocked in the no-load position, as approved by the DCES.

1214.3 Deviation from Specified Camber in Assembly

-0, + $\frac{1}{8}$ x $\frac{\text{No. of feet of length from nearest support (bearing or pin)}}{10}$, or $\frac{3}{4}$ inch, whichever is less

1214.4 Deviation from Specified Camber of Erected Steel Bridge Superstructures.

a) cantilever sections

-0, + $\frac{1}{4}$ x $\frac{\text{No. of feet of length from nearest support (bearing or pin)}}{10}$, or $\frac{3}{4}$ inch, whichever is less

b) between substructure supports

-0, + $\frac{1}{4}$ x $\frac{\text{No. of feet of length from nearest support (bearing or pin)}}{10}$, or $1\frac{1}{2}$ inch, whichever is less

Unless otherwise specified, all measurements shall be taken when the steel erection is complete and the superstructure is subject to steel dead load stresses only.

1215. DEVIATION FROM VERTICAL ALIGNMENT OF GIRDER WEBS

The maximum deviation of girder webs from vertical at points of support shall be $\frac{1}{4}$ inch or $\frac{3}{32}$ inch/foot [6 mm/m] of web depth, not to exceed $\frac{3}{4}$ inch [19 mm]. The deviation of girder webs from vertical at mid-span locations may exceed the above requirements subject to the approval of the DCES.

1216. TOLERANCES FOR JOINT FIT-UP IN WELDED CONNECTIONS

See AWS D1.5 Figure 2.5 for PJP and Section 1101.1 for fillet welds.

Notes:

SECTION 13

CLEANING AND PROTECTIVE COATINGS

1301. PAINTED STEEL

When structural steel is required to be painted, cleaning and painting shall be in accordance with the appropriate bid item in the Contract Documents. The steel shall be cleaned with SSPC-SP1 (Solvent Cleaning) to remove any oil, grease, crayon markings, etc. and then blast cleaned to SSPC-SP10 (Near White Blast Cleaning) prior to final QA visual inspection. If the surface is allowed to deteriorate, an SSPC-SP10 blast shall be reestablished at no additional cost to the state. Generally, re-blasting of the surface prior to painting is not necessary provided it meets the time requirements of the Specification and the requirements for a SSPC-SP10 (Near White Blast Cleaning) surface preparation.

If, because of prolonged storage, delays in final field painting schedules, or for any other reason; the shop-applied protective coating deteriorates to the point where it is unacceptable, the Contractor shall restore the original protective coating to an acceptable condition at no additional cost to the State before continuing with field painting or other field coatings.

1302. UNPAINTED WEATHERING STEEL

When structural steel is not required to be painted, the steel shall be cleaned with SSPC-SP1 (Solvent Cleaning) to remove any oil, grease, dirt, paint, chalk, or crayon markings, etc., and then blast cleaned to SSPC-SP6 (Commercial Blast Cleaning) prior to final QA visual inspection.

After blasting and prior to shipment from the fabrication shop, all exterior areas of fascia steel shall be pressure washed with a stream of potable water to ensure uniform weathering. When washing is complete, the cleaned surfaces shall be free of chalk or crayon markings, dust, dirt, grease, and other debris.

1303. BOLTED SPLICES / CONNECTIONS

At the discretion of the Contractor/Fabricator, and as indicated on the approved shop drawings, contact (faying) surfaces of all bolted connections, of painted structures, shall be masked and unpainted or shall be primed with an approved organic-zinc rich primer meeting the NEPCOAT requirements of Slip B or Slip D, and which is on the NYSDOT Materials Bureau Approved List for Structural Steel Paint Class 1. Cleaning of the contact surfaces prior to painting shall be in accordance with Section 1301. The maximum dry film thickness for the primer shall be as noted on the Approved List.

Primed faying surfaces of all primed bolted connections shall be masked within 3 inches (75 mm) of all open holes prior to application of the intermediate and final coats of paint. Touch-up field painting of the intermediate and final coats shall be applied after assembly of the connection.

Faying surfaces of new painted or unpainted steel structures which have become fouled prior to assembly shall be cleaned in accordance with SSPC-SP1, (Solvent Cleaning) to remove oil, grease, dirt and other foreign material prior to final assembly.

Faying surfaces of existing painted or unpainted steel structures receiving new steel shall have the faying surfaces cleaned in accordance with SSPC-SP1 (Solvent Cleaning) to remove oil and grease and blast cleaned in accordance with SSPC-SP6 (Commercial Blast Cleaning) to remove temporary protective coatings, dirt, rust, paint, and other foreign material prior to erection.

It is not necessary to mask faying surfaces of metalized structures prior to metalizing. Faying surfaces of galvanized or metalized structures shall not be brushed or otherwise treated except to remove oil, grease,

dirt, or other foreign material. Clear coat over metalized surfaces shall **not** be applied to the faying surfaces.

1304. MACHINED SURFACES

Machine finished surfaces in sliding contact, including pins, pin holes, surfaces in sockets at the top of rocker bearings, etc, shall receive one coat of automotive grease as soon as machining is complete. Bronze plates in sliding contact shall also be coated with grease. The Contractor shall maintain all protective coatings to prevent corrosion. All protective coatings applied in the shop shall be removed immediately prior to erection of the superstructure. When the protective coating is removed, the parts shall be thoroughly cleaned and then coated with grease before erection of the superstructure. All other machine finished surfaces shall be painted as specified in the Contract documents. Method of paint removal shall not disturb the machine finish. (i.e. gouges, scratches, surface roughening, etc.)

1305. GALVANIZED COATINGS

When galvanizing is required, it shall conform to the requirements of §719-01 *Galvanized Coatings and Repair Methods* of the Standard Specifications. Welds that are to be galvanized shall be blast cleaned or otherwise treated to remove slag and any other material that will interfere with proper galvanizing.

SECTION 14 STORAGE, TRANSPORTATION & ERECTION

1401. STORAGE OF MATERIALS

Structural material shall be stored above the surface of the ground on platforms, skids, or other supports, and shall be protected as far as practical from surface deterioration and kept free from accumulations of dirt, oil, or other foreign matter. No material shall, at any time, be dropped, thrown, or dragged on the ground. Girders and beams shall be handled and stored with their webs vertical and shall be adequately shored, braced, and/or clamped to resist any lateral forces which might occur. Long members such as columns and chords shall be supported at a sufficient number of intermediate locations to insure that there is no damage from deflection. Permanent distortion resulting from improper handling or storage will be cause for rejection.

Any damage incurred during storage at the shop for any reason shall be corrected by the Fabricator prior to acceptance for shipment by the Inspector. All fabricated material stored by the Contractor at the jobsite or other approved location will be subject to inspection by the Engineer and any corrective action required as the result of damage during storage shall be performed by the Contractor.

Repairs to damaged structural steel shall be done in accordance with procedures approved by the DCES.

1402. TRANSPORTATION

1402.1 Marking for Shipping. Erection pieces with computed weights exceeding three tons shall have the lifting weight to the nearest one-half ton marked thereon. Bolts and rivets of one length, nuts and washers shall be packaged separately by diameter. Pins, small parts, and small packages of bolts, rivets, washers, and nuts shall be shipped in boxes, crates, kegs, or barrels. The gross weight of any package shall not exceed 300 pounds. A list and description of the contained material shall be plainly marked on the outside of each shipping container. Shipping containers for high strength fasteners shall have the manufacturer's control lot numbers marked on the outside.

The weight of all tools and erection material shall be kept separate.

1402.2 Shipping. All handling, loading, transportation, unloading and storage of structural material shall be conducted so that the metal and all protective coatings will be kept clean and free from injury.

Structural members shall be suitably supported and braced so that they will not be subjected to stresses in excess of those provided for in the design. Pieces assembled bolt to ship shall be wrench tight and shown that way on the approved drawings.

The method of shipment and requirements for transportation drawings shall conform to Section 206.

1403. ERECTION OF STRUCTURAL STEEL

1403.1 General. The Contractor's proposed structural steel erection procedure shall be described on erection drawings submitted to DCES for review. These drawings shall meet all provisions of Section 204, and when necessary, conform to the requirements of §105-09 *Work Affecting Railroads* of the Standard Specifications.

Pedestrians shall be protected at all times and no erection work shall be done over traffic on roadways, bikeways, waterways, and railroads. No erection work shall begin prior to the review of the erection procedure by the DCES and affected railroads and review of the work zone traffic control by

the Regional Director of Transportation. This review shall not be considered as relieving the Contractor of the responsibility for the safety of the method or equipment used, or for the responsibility of carrying out the work in accordance with the requirements of the Contract documents.

1403.2 Erector Requirements. The structural steel erector shall have adequate personnel, organization, experience, procedures, knowledge, and equipment capable of producing quality workmanship. Additional criteria contained in the contract documents may be required for the erection of extremely complicated structures, such as innovative and movable steel bridges.

Additional criteria contained in the contract documents may be required for the erection of extremely complicated structures, such as innovative and movable steel bridges.

1403.3 Falsework. Curved girders and long span straight girders shall be stabilized with falsework, temporary braces, or holding cranes until a sufficient number of adjacent girders are erected with all diaphragms and crossframes connected to provide the necessary lateral stability. All trusses shall be erected on falsework unless otherwise approved by the DCES. The falsework shall provide for proper camber and alignment and shall be properly designed, constructed, and maintained for the loads which will be imposed upon it. When erecting trusses, the falsework shall be left in place until all connections are bolted and accepted by the Engineer unless otherwise provided in the erection procedure. Care shall be taken in the use of falsework and other temporary supports to insure that the temporary elevation of structural steel provided by the falsework is consistent with the deflections that will occur as the structure is completed. Holding cranes, when allowed by the DCES, shall have a minimum working capacity of 50% of the load.

Bridge railings shall not be bolted or welded in their final position until the falsework has been removed. Deadmen are not allowed for stabilization.

1403.4 Field Connections. Bolting or welding procedures necessary to complete the erection of the structure shall be shown on the erection drawings. The procedures shall include the sequence and method for connecting main members and secondary members. For stringer and girder spans, the following minimum information shall be included in the notes, modified as necessary to conform to design and erection requirements for each structure:

Members erected on bearings or falsework shall have splices and field connections of main stress carrying members made with a minimum of 50% of the holes filled with approved high strength bolts and full size erection pins before the external support systems are released. At least one-half of this percentage shall be bolts, tightened to specification requirements. The bolts and pins shall be installed uniformly throughout the connection except that erection pins shall be used in the extreme corners of all main connections.

Members to be assembled on the ground before erection shall be blocked to their proper no load profile and 100% of the approved high strength bolts shall be installed and tightened to specification requirements before erecting the member. Blocking locations and elevations shall be shown on the erection drawings.

All diaphragms and crossframes shall be installed as the work progresses unless the Contractor shows by calculation and the DCES approves a lesser amount as sufficient to stabilize the member. All diaphragms between adjacent girders shall be connected before release of the crane or other lifting device unless modifications have been requested and approved consistent with Section 204. When applicable, the number and location of diaphragms and crossframes needed to insure lateral stability of the members during all phases of the erection procedure, including during the lifting and upon release of the member, shall be shown on the erection drawings.

Between the first two lines of straight girders, each diaphragm or cross frame to girder connection shall be made with at least 50% of the holes filled with approved high strength bolts. The bolts shall be tightened until there is no gap between the connected parts. After the first two lines are erected and stabilized, diaphragms or crossframes installed between subsequent lines of girders may have each of their connections made with a minimum of two approved high strength bolts installed in each connection unless a greater number of bolts is required for stability. The bolts shall be tightened until there is no gap between the connected parts.

Between all lines of curved girders, each diaphragm or crossframe to girder connection shall be made with at least 50% of the holes filled with approved high strength bolts. The bolts shall be tightened until there is no gap between the connected parts. Lateral bracing shall be installed with 50% of the bolts.

If surfaces which are to be connected by field bolting or field welding have been painted or become rusted or contaminated with any foreign material that would make these connecting procedures unacceptable, the Contractor shall clean the surfaces at no additional cost to the State. A tight coating of light rust will be permitted on faying surfaces of bolted joints. No rust will be permitted at the fusion boundaries of groove welds.

Bolting procedures shall be in conformance with Section 10.

Erection bolts shall be the same nominal diameter and shall conform to the same specification as the final bolts. Cylindrical erection pins shall be the same size as the hole.

1403.5 Repair of Damaged or Misaligned Steel. All damaged or misaligned structural steel shall be straightened or corrected by procedures approved by the DCES. The method of repair proposed by the Contractor shall be submitted on a standard shop drawing for approval of the DCES prior to beginning the work. Approval, when granted, shall not relieve the Contractor of the responsibility for the successful completion of the work.

1403.6 Field Reaming and Drifting of Holes on New Bridge Projects:

Members shall be subject to only light drifting to align holes. Any members subjected to drifting that results in distortion of the member or elongation of the holes will be rejected.

Main members and secondary members with oversize holes shall not be field reamed without approval of the DCES.

Secondary members which have holes punched full size may be subjected to limited field reaming when approved by the DCES. If approved, reaming shall not elongate holes by an amount greater than $\frac{1}{16}$ inch for 75% of the holes in any erection sub-assembly and $\frac{1}{8}$ inch for the remaining 25% of the holes in the erection sub-assembly, i.e., diaphragm, lateral brace, etc.

The DCES may approve additional reaming of secondary members provided adequate edge distances and fastener spacing are maintained and the next larger size fastener is used. The edge distances shall be considered the same for either a rolled or planed edge.

Field reaming producing results exceeding the limits previously described, will be cause for rejection of the member.

1403.7 Field Drilling, Reaming and Drifting of Holes on Bridge Rehabilitation Projects:

The method of preparing holes shall be clearly indicated on the shop drawings. If the Contractor proposes a method not included in this Section, DCES approval will be required.

1403.7.1 Field Drilling New Steel:

When bolt holes in new repair material are required to match an existing rivet/bolt pattern, they shall be prepared using one of the following methods:

1. The Contractor shall bring new repair steel out to the field blank (without pre-drilled holes). After assembly and alignment, holes in the existing steel shall be used as a one time template to field drill full size holes in the new steel.
2. The Contractor shall create an approximate pattern of existing rivet holes using field measurements and the existing contract plans. This pattern shall be used to drill ¼ inch subsize holes in the new steel in the shop. Thereafter, these holes shall be (RTA) reamed to full size in the field, using the existing steel component and its associated holes as a one time template.

1403.7.2 Field Drilling Existing Steel:

When new bolt holes are required in existing material, they shall be prepared in the field using one of the following methods:

1. Full size holes shall be drilled using holes in new material as a one time template. (CNC-MDT)
2. Full size holes shall be drilled using a steel template with hardened bushings. (DT)

The Contractor shall be provided one payment for each hole location designated to be field drilled regardless of the number of plies field drilled.

1403.7.3 Field Reaming and Drifting of Holes:

Field reaming and drifting of holes shall be required when holes in the existing plies do not line up.

After reaming, holes shall be perpendicular to the faying surface and 75% of the group of holes shall not be elongated greater than $\frac{1}{32}$ inch. The remaining 25% of the group shall not be elongated greater than $\frac{1}{16}$ inch. If any bolt hole, after reaming, is more than $\frac{1}{8}$ inch larger than the nominal size of the bolt indicated on the drawings, the next size bolt shall be used.

Should oversize bolts be required, the Engineer shall be notified for approval.

1403.8 Adjustment of Pin Nuts. All nuts on pins shall be properly tightened and locked as specified on the plans or approved by the DCES. The pins shall be aligned in the holes so that the members shall take full and even bearing upon them.

1404. REMOVAL OF RUST AND STAINS FROM CONCRETE

All rust and other stains shall be removed from concrete surfaces in accordance with the requirements of the Standard Specification entitled *Structural Concrete*. This requirement shall apply for cleaning all new concrete as well as for cleaning all existing concrete stained or damaged by the Contractor's operations. If the Contractor elects to reduce concrete staining and rusting of surfaces which must be cleaned, the Contractor may, at no additional cost to the State, spray unpainted portions of steel members with an approximately one mil thick coat of commercial lacquer that has been given a slight coloration that will denote its presence. This lacquer coating may remain on all surfaces which are to be imbedded in, or are to be in contact with, concrete. The lacquer must be removed from all contact surfaces of bolted connections, from within three inches of a welded joint, and from areas that will subsequently be covered by field painting.

1405. FIELD INSPECTION

All erection shall be subject to the inspection of the Engineer-in-Charge, who shall be given all facilities required for a thorough inspection of the work. Materials and workmanship subject to shop inspection are identified by the acceptance stamp of the Shop Inspector as described in Section 303.7. Materials and workmanship not required to be shop inspected shall be inspected by the Engineer. Certified copies of the results of tests conducted by the manufacturer shall be furnished to the Engineer in accordance with the requirements of the specification for that item.

1406. FIELD REPAIR

All repairs to structural steel shall be subject to approval by the DCES.

SECTION 15 HEAT CURVING, CAMBERING AND STRAIGHTENING

1501. HEAT CURVING ROLLED BEAMS AND WELDED PLATE GIRDERS

1501.1 General. Rolled beams and welded plate girders designed to be built with a specified horizontal curvature may be fabricated using heat curving procedures which conform to the following requirements and which are to be approved by the DCES provided that the Plans or Specifications do not require other methods of producing the required curvature.

Steels that are manufactured to a specified minimum yield point greater than 50,000 psi shall not be heat-curved, cambered or straightened without the written approval of the DCES.

Members required to be fabricated to a radius shorter than the minimum radius of curvature as described in this Section shall be fabricated as welded plate girders with the flanges oxygen cut to the required radius prior to assembly to the web.

Generally, members shall be heat curved at the fabricator's plant. Stringers and girders may be heat curved at the job site provided the Contractor bears all additional costs for field heat curving, including field inspection by an approved inspection agency, cleaning, and painting.

Heat Curving (Sweep) Reports shall be submitted to the DCES after acceptance by the State inspector.

1501.2 Minimum Radius of Curvature. Heat curving of beams and girders will be allowed when the horizontal radius of curvature measured to the centerline of the member web is greater than both values calculated by the following two equations, and greater than 150 ft [45.7 m] at any and all cross sections throughout the length of the member.

$$R = \frac{14 b D}{\sqrt{F_y P t}}, \quad R = \frac{7500 b}{F_y P}, \text{ where:}$$

F_y	=	specified minimum yield point in ksi of the member web.
P	=	ratio of the total cross section area to the cross sectional area of both flanges.
b	=	width of the widest flange in inches.
D	=	clear distance between flanges in inches.
t	=	web thickness in inches.
R	=	radius in inches.

In addition to the above, when the required radius of curvature is less than 1000 ft.[30.5 m], and the flange thickness exceeds 3 inches [75 mm], or the flange width exceeds 30 inches [762 mm], heat curving will not be allowed.

1501.3 Camber Increase for Dead Load Deflection Caused by Residual Stresses. To compensate for possible loss of camber of heat curved girders (camber losses of this nature are also known to occur in straight beams and girders but to a lesser degree) in service as residual stresses dissipate, the amount of camber in inches at the point of maximum deflection may be increased by the amount shown in the following formula:

$$\Delta \text{ increase} = \frac{0.02L^2 F_y}{E_y}, \text{ where:}$$

- F_y = specified minimum yield point in ksi of the girder flange.
- L = span length or distance between points of dead load contraflexure in inches.
- E = modulus of elasticity in ksi.
- y_o = the distance from the neutral axis of the steel member to the extreme outer fiber in inches (maximum distance for non symmetrical sections).

Any camber increase indicated by the formula shall be approved by the DCES who may multiply the formula result by a factor of 0.5 to 0.95 based upon experience with long term deflections.

Distribute Δ increase from the point of maximum deflection as a parabola. This distribution shall be between dead load points of contraflexure. Fifty percent of this camber increase may be included in the bridge profile because camber loss will not be complete until after several months of service. The remaining fifty percent of the camber increase may be included in the anticipated steel dead load deflection. This shall include all steel deflection prior to composite action between the steel superstructure members and any attached concrete designed to act as a composite section.

1501.4 Preparation for Heat Curving. Members shall be heat curved prior to completion of the following work unless otherwise approved by the DCES:

- a) Attachment of end bearing stiffeners.
- b) Attachment of lateral gusset plates.
- c) Attachment of longitudinal stiffeners.
- d) Welding of intermediate stiffeners and connection plates to the flanges.
- e) Shop or field painting.

When longitudinal stiffeners are required, they shall be heat curved or oxygen cut to the required radius prior to being welded to the curved girder.

1501.5 Support of Members for Heating. Members may be heat curved with the web in either the vertical or horizontal position.

When the radius is less than 1000 ft. [305 m], members must be heat curved with the web in the horizontal position, or preloaded to induce stress prior to heating.

When the member is heat curved with the web in the horizontal position, the member must be supported at its ends and at intermediate points as required to produce a uniform curvature in the member and compressive stresses in the upward projecting flange legs throughout the full length of the piece being curved. Intermediate safety catch blocks shall be maintained at mid-distance between supports of the member and not more than two inches below the flanges at all times during the heating process to catch the member in case of a sudden sag due to plastic flange buckling.

When the member is heat curved with the web in the vertical position, the member must be braced or supported in such a manner that the tendency of the member to deflect laterally during the heat curving process will not cause the member to overturn.

The method of supporting or loading shall be described on a sketch sheet and submitted to the DCES with copies of the design computations in accordance with Section 2.1.3.21. The method of support and computations for preloading shall be approved prior to beginning the work. Preload compressive stresses will be permitted up to a maximum of $0.55 \cdot F_y$. Preloading as specified herein will reduce the number of heating patterns required to produce the desired curvature.

Any method of handling, supporting, or loading that causes the member to distort permanently (yield without the application of heat) will result in rejection of the member. All nondestructive tests to

evaluate damage and any corrective work ordered by the State to compensate for overstressing shall be performed by the Contractor at no cost to the State.

1501.6 Heating Process and Equipment. Heating shall be performed using large, approximately 1 inch diameter, multiorifice (rosebud) torches using a multi-fuel (i.e. propane, propylene, map, natural gas, etc.) unless otherwise approved by the DCES. The torches and tips to be used will be subject to the approval of the DCES. Selection shall be made to promote heating efficiency and prevent unnecessary distortion.

Heating shall be confined to the patterns described herein and shall be conducted to bring the steel within the planned pattern to a temperature between 1,000° F [540° C] and 1,150° F [620° C] as rapidly as possible without overheating the steel.

Any heating procedure which causes a portion of the steel to be heated to a temperature greater than 1,250° F [675° C] shall be considered destructive heating. Destructive heating shall automatically cause the rejection of the steel. Steel rejected for destructive heating shall be investigated for reacceptance, repair, or replacement by tests ordered by the DCES. The cost of such tests and any necessary repair or replacement shall be borne by the Contractor.

1501.7 Location of Heating Patterns. Heating patterns shall be spaced uniformly along the full length of each flange to produce a circular (not parabolic) curvature. Sufficient heating patterns shall be used in each piece to eliminate unsightly chording effects. Heating patterns shall be adjusted to produce the necessary curvature, compensating for differences in flange thickness and width as necessary. Thicker and wider plates, in general, require wider heating patterns to produce the same amount of curvature. Care shall be taken when heating relatively thin, wide plates to guard against flange buckling.

1501.8 Heating Patterns and Method of Heating. Only truncated triangular heating patterns shall be used. The base of the triangle shall be the flange edge that will be concave after curving. The apex of the heating triangle shall be truncated to provide a [1 inch [25mm] width. The truncated end of the heating triangle shall be located as follows:

- a) When the required radius is 1000 ft. [30.5 m], or less, the truncated end of the heating triangle shall be located $\frac{1}{4}$ of the flange width but not more than 2 inches beyond the intersection of the web and flange.
- b) When the required radius is greater than 1000 ft. [30.5 m], the heating pattern may be as described above or may, at the fabricator's option, be modified to locate the truncated end of the heating triangle at the junction of web and flange.

Heating patterns shall be marked on the flange surfaces prior to heating. Heat shall be applied to the top and bottom flange at essentially the same location in the member. Beginning at the truncated end of the heating pattern, heating shall progress slowly toward the base of the pattern spreading with an included angle of 15 to 30 degrees. The base of the heating triangle shall not exceed 10 inches [250 mm] regardless of flange width and thickness. The heating torches shall not begin to progress toward the base of the heating pattern until the truncated end of the pattern is brought up to the specified temperature. Once heating begins to progress towards the base at the pattern, the heating torch(es) shall not be returned to the apex of the heating triangle. When the flange thickness exceeds 1¼ inch [32 mm], both surfaces of the flange shall be heated simultaneously. Heat shall not be applied to the inside flange surface until the heat being applied to the outside surface has progressed beyond the web and flange junction. When heating the inside flange surface, the truncated end of the heating triangle shall be just inside the junction of web and flange and the triangle shall share a common base with the heating pattern on the outside of the flange at that point.

The heating torches shall be manipulated to guard against general and surface overheating. When heating thick plates, it may be necessary to occasionally interrupt heating for periods of less than one minute to allow the heat to soak into the flange and avoid surface overheating.

1501.9 Heat Measurement. The Contractor shall provide the Inspector with temperature indicating crayons manufactured for 600° F, 1,000° F, 1,100° F and 1,250° F [315° C, 540° C, 590° C, and 675° C]. Heat measurements shall be made after the heating flame has been removed from the steel.

1501.10 Artificial Cooling. Quenching with water or water and air will not be permitted. Cooling with dry compressed air will be permitted after the steel has cooled to 600° F [315° C].

1501.11 Control of Web and Flange Distortion. Web distortion is the first indication that the heating process is not being conducted properly. Web or flange distortion in excess of that allowed by this manual will not be permitted. When intermediate stiffeners are placed on only one side of a girder web, temporary intermediate braces, i.e., wood blocks or posts, must be placed on the opposite side during heating to prevent rotation of the flange during the heating process. When heating the inside flange surface, the torches shall be directed to prevent applying heat directly to the web.

1501.12 Web Cutting for Heat Curved Welded Plate Girders. The fabricator shall cut sufficient extra camber into the webs of plate girders to provide for all camber losses during fabrication and heat curving. The heat curving process will in general not cause as much camber loss during fabrication as welding of the web to flanges and welding of stiffeners and connection plates to the compression flange.

1501.13 Rolled Beams with Cover Plates. When rolled beams are fabricated with cover plates, the cover plates may be attached before heat curving if the total thickness of one flange plus cover plate is less than 2 inches and the radius of curvature is greater than 1000 ft. [30.5 m]. When rolled beams with cover plates attached are heat curved, two torches shall be used regardless of flange and cover plate thickness, and the Contractor shall magnetic particle inspect the flange to cover plate fillet welds. This work shall be performed after all heating is complete and shall conform to the requirements of Section 18.

All other rolled beams with cover plates must be heat curved before the cover plates are attached. The cover plates shall be either heat curved or oxygen cut to the required radius before being welded to the curved beam.

1502. CAMBERING OF ROLLED BEAMS AND HEAT CAMBERING OF WELDED PLATE GIRDERS

1502.1 General. All provisions of Section 1501 shall apply except as modified by this Section. Heat cambering procedures shall be approved by the DCES prior to beginning the work. When heat cambering is approved, only deep vee heating patterns will be permitted.

Camber Reports for individual pieces and, if applicable, for line assembly shall be submitted to the DCES after acceptance by the NYS inspector.

1502.2 Cambering of Rolled Beams. Rolled beams not designated as fracture critical members, may be either heat or cold cambered to provide the required curvature. Cold cambering may not be performed on fracture critical rolled sections, such as floorbeams spaced more than 12' on center. For beams with excessive camber requirements (more than 1 ½" per 20' of length), cold cambering is prohibited.

For heat cambering, triangular heating patterns shall be spaced per approved procedure. The apex of the heating triangle shall be located in the web at a point not less than 75 percent of the depth of the member from the flange that will be concave after cambering. Heating shall begin at the apex of the heating pattern and progress slowly with a total included angle not exceeding 20 degrees towards the

base of the pattern and across the full width of the flange as described in Section 1501.8

The heating torch shall not be returned to the apex of the heating triangle after heating has progressed towards the base. Preloading may be performed as described in Section 1501.5. Heating patterns shall be centered on connection plates whenever possible.

When rolled beams are to be fabricated with cover plates, the rolled beams shall be cambered prior to the attachment of the cover plates.

All detail material such as connection plates, bearing stiffeners, and gusset plates shall be attached to the rolled beam after the beam has been cambered.

1502.3 Heat Cambering of Welded Plate Girders. Heat cambering of welded plate girders and any proposed preloading shall be approved by the DCES prior to beginning the work.

Heating will only be permitted in deep vee heating patterns centered on intermediate stiffeners and connection plates. In some cases, additional stiffeners may be required to provide sufficient heating sites. This provision is designed to prevent or reduce web distortion. The apex of the heating pattern shall be located in the web not less than 75 percent of the depth of the member from the flange that will be concave after cambering. The maximum included angle of the heating pattern shall be 10 degrees. The maximum width of the base of the heating pattern shall be 10 inches [250 mm]. Where shallow members or thin webs require heating patterns with a width substantially less than 10 inches [250 mm] at the junction of the web to flange, the heating pattern in the flange may extend beyond the limits of the heating pattern in the web by a maximum of one inch on each side provided the total width of pattern in the flange does not exceed 10 inches [250 mm].

1502.4 Support of Members for Heat Cambering. Members to be heat cambered shall be supported with the web vertical and with the flange which will be concave after cambering placed upwards. Supports shall be spaced to take the maximum advantage of dead load in the member before heat is applied. Members may be supported with the web horizontal if an approved preloading procedure is used.

1503. HEAT STRAIGHTENING DAMAGED STRUCTURAL STEEL

All heat straightening procedures shall be subject to prior approval by the DCES. Straightening procedures shall describe in detail the distortion to be corrected and all procedures for preloading, heating, cooling, verifying final dimensions, and nondestructive tests. All work shall be done in accordance with the SCM and witnessed by the State inspector at no cost to the State.

1504. REPAIRS

When a repair has been allowed by the DCES, the Fabricator shall submit the proposed Heat Repair Procedure to the DCES for approval. The repair procedure shall follow the requirements of Section 15 but may include the use of different size torches, heating patterns (strip, star), locations of heats, etc. to accommodate the type of repair.

The types of repairs shall include but are not limited to: correction of flange tilt, flange cupping, web buckles and distortion due to welding.

All repairs shall be done in accordance with the SCM and witnessed by the State inspector at no cost to the State.

Notes:

SECTION 16 RADIOGRAPHIC TESTING

1601. GENERAL

The procedures and standards set forth herein are to govern radiographic testing of groove welds in butt joints in plates, shapes, and bars by X-ray or gamma ray sources. The methodology shall conform to ASTM E94, "Standard Guide for Radiographic Testing," and ASTM E1032, "Standard Test Method for Radiographic Examination of Weldments," except as provided herein.

Any variation from the provisions of these specifications must have prior approval of the DCES, and shall be confirmed in writing. Such variations include, but are not limited to:

- a) Radiographic testing of fillet, tee, and corner welds,
- b) Changes in source-to-film distance,
- c) Unusual application of film,
- d) Unusual penetrometer applications including film side penetrameters and wire penetrameters,
- e) Radiographic testing of thicknesses greater than six inches and
- f) Film types, densities, and variations in exposure, development, and viewing techniques.

All radiographic inspection performed by State personnel, inspection agencies under contract to the State, Contractors or their agents working on State contracts shall conform to the requirements of this specification.

1602. EXTENT OF TESTING

1602.1 Butt Joints in Primary Tension Members. All butt joints in primary tension members shall be radiographed. This shall include all tension flange butt welds and the tension portion of web butt welds in stringers and girders. Joints to be radiographed shall also include tension butt welds in columns, bents, towers, rigid frames, arches, truss chords, truss web members, and longitudinal stiffener splice welds when attached to the tension areas of members.

Radiographic inspection will be used to determine the soundness of tension butt welds throughout their entire length unless otherwise specified.

1602.2 Web Splices. Tension areas of web splices in stringers and girders shall be interpreted to represent one third of the web butt joint, with a minimum length of 16 inches, beginning at the tension flange unless otherwise specified. When a web joint is subject to reversal of stress, the entire web (100%) and both flange joints shall be radiographed.

1602.3 Field Splices. Butt welded field splices in structural members shall be subject to 100 per- cent examination by radiographic inspection unless otherwise specified.

1602.4 Repairs. "Spot" inspection and "spot" radiography shall not be used except for the examination of localized repairs in welds previously rejected by radiographic tests. Repair radiographs shall represent a minimum length of weld equal to the repair excavation plus 3 inches each side.

1602.5 Radiographic Inspection of Welds Subject to Shear or Compression. Twenty-five percent of each butt joint in compression on each girder or at the Fabricator's option, twenty-five percent of the total butt joints in compression on each girder (with a minimum of one complete joint) shall be subject to radiographic inspection.

All compression and shear joints in a member shall be radiographed when any radiograph in a tension joint in the member has an accumulative discontinuity length which exceeds 10 percent of the length of the joint.

1602.5.1 Radiographic Inspection of Spiral Welded Pipe. The fabricator may opt for continuous radiographic inspection and documentation during production as per their established procedure, which will be subject to DCES approval. Alternatively, 25% of the weld length in each pipe may be radiograph or UT inspected as per the provisions of this section.

1602.6 Extension of Test Area. If defects are found in any area which is subject to partial examination, the area examined shall be extended to insure that the limits of the rejectable discontinuities have been discovered and repaired. If the extended area examined contains rejectable discontinuities, the complete weld shall be radiographed.

1603. FRAUDULENT RADIOGRAPHS

The State may order new and separate radiographic inspection of all butt welds in all structural steel fabricated for the State in a given shop when there is evidence, in the opinion of the DCES, that the Fabricator has submitted fraudulent radiographs or reports

1604. RADIOGRAPHIC PROCEDURE

1604.1 General. Radiographs shall be made using a single source of X- or gamma radiation. The radiographic sensitivity shall be judged based on penetrameter image. Radiographic technique and equipment shall provide sufficient sensitivity to clearly delineate the required penetrameters and the essential holes as described in Table 1604.1. Identifying letters and numbers shall show clearly in the radiograph. Radiography shall be performed in accordance with all applicable safety requirements.

All joints shall be prepared for radiography by grinding as described in Section 723 Quality of Welds (Bridges). Weld profiles shall be as described in Section 723 Quality of Welds (Bridges). Extension bars and run off plates shall be removed prior to radiographic inspection.

When joints are ground in accordance with the provisions of Section 723 Quality of Welds (Bridges), steel shims will not be required under the penetrameter.

TABLE 1604.1- PENETRATOR REQUIREMENTS

Nominal material Thickness range (inches)	Penetrator Identification	Penetrator Thickness	Essential Hole
Up to 0.375	12	0.012	4T
Over 0.375 to 0.625	15	0.015	4T
Over 0.625 to 0.75	17	0.017	4T
Over 0.75 to 1.00	20	0.020	4T
Over 1.00 to 1.25	25	0.025	4T
Over 1.25 to 1.50	30	0.030	2T
Over 1.50 to 2.00	35	0.035	2T
Over 2.00 to 2.5	40	0.040	2T
Over 2.5 to 3.00	45	0.045	2T
Over 3.00 to 4.00	50	0.050	2T
Over 4.00 to 6.00	60	0.060	2T

1604.2 Preparation for Exposure

1604.2.1 General. All film cassettes shall be loaded with two films of the same specification. Appropriate lead screens shall be used. A center screen is recommended when the steel thickness exceeds 1 ¼ inches [31 mm]. The loaded cassette shall be held in intimate contact with the steel by a process that will avoid film pressure marks. The back side of the cassette shall be protected from scatter radiation for its full length and width by a lead sheet.

1604.2.2 Film Type. Radiographic film shall be Type 1 or Type 2 as described in ASTM E94. Lead foil screens shall be used as described in ASTM E94. Fluorescent screens shall not be permitted.

1604.2.3 Film Size. When the joint thickness is less than 3 inches [75 mm], radiographs may be 4½ inches [110 mm] by 17 inches [430 mm] in size. When the length of the joint is such that more than one radiograph is required, one of the films may be shortened to 4 ½ inches [110 mm] by 10 inches [250 mm] if the Contractor elects to do so. When joint thicknesses are 3 inches [75 mm] or greater, the minimum film size shall be 7 inches [175 mm] by 17 inches [430 mm]. Larger radiographs may be required in areas where there have been excessive repairs or to radiograph joints with unusual dimensions. All repair radiographs shall be made using 4½ inches [110 mm] by 17 inches [430 mm] or larger film.

1604.2.4 Radiographic Sources. Gamma ray sources, regardless of size, shall be capable of meeting the geometric unsharpness requirement of ASME Section V, Article 2. X-ray units, 600 kvp maximum and Iridium 192 may be used as a source for all radiographic inspection provided they have adequate penetrating ability. Cobalt 60 may be used as a radiographic source only when the steel being radiographed is 3 inches [75 mm] or greater in thickness.

1604.2.5 Penetrators. Penetrators shall be manufactured from steel, preferably stainless steel, and shall conform to the dimensions shown in Figure 1604.2a. Each penetrator shall be manufactured with three holes, one of which shall be of a diameter equal to twice the penetrator thickness (2T). The diameter of the two remaining holes shall be selected by the manufacturer. They will ordinarily be equal to one times (1T) and four times (4T) the penetrator thickness. Penetrator designations 7 through 25 shall contain a 4T hole. For more detailed information, see ASTM E142.

The thickness of the penetrameter and the essential hole shall be as specified in Table 1604.1. A smaller essential hole and/or a thinner penetrameter may be used provided all other provisions for radiography are met.

Thickness shall be measured as T_1 and/or T_2 at the locations shown in Figures 1604.2b and 1604.2c. Penetrameters shall be placed on the source side, parallel to the weld joint, with the holes at the outer end as detailed in Figures 1604.2b and 1604.2c. The use of film side penetrameters shall be cause for rejection of the radiographs.

At least two penetrameters, one at each end of the joint or film, shall show clearly on each radiograph as shown in Figure 1604.2b. When a transition in thickness occurs at a welded joint, each film shall clearly show two penetrameters on the thinner plate and one penetrameter on the thicker plate as shown in Figure 1604.2c. Steel backing, when allowed, shall not be considered part of the weld thickness in penetrameter selection.

1604.2.6 Technique. Radiographs shall be made with a single source of radiation centered as near as practical with respect to the length and width of that portion of the weld being examined.

The source to subject distance shall not be less than the total length of film being exposed. In addition, the source to subject distance shall not be less than the amount shown in the following table nor such that the inspecting radiation shall penetrate any portion of the weld represented in the radiograph at an angle greater than $26\frac{1}{2}^\circ$ from a line normal to the weld surface, unless otherwise approved by the DCES:

Maximum thickness of weld under examination (T)	Minimum source to subject distance
> ¼" to 2", inclusive > 6 mm to 50 mm incl.	24" 600 mm
> 2" to 2 ½", inclusive > 50 mm to 60 mm	18" 450 mm
> 2 ½" > 60 mm	7T

Welded joints shall be radiographed and the film indexed by methods that will provide complete and continuous inspection of the joint within the limits specified to be examined. Joint limits shall show clearly in the radiographs. Short film, short screens, excessive undercut by scattered radiation, or any other process that obscures portions of the total weld length shall render the radiograph unacceptable. Films shall have sufficient length and shall be placed to produce at least ½ inch [12 mm] of film, exposed to direct radiation from the source, beyond each free edge where the weld is terminated.

Welds longer than 14 inches but less than 30 inches in length may be radiographed by overlapping film cassettes and making a single exposure, or by using single film cassettes and making separate exposures.

The method used shall provide complete and continuous inspection, produce radiographs of acceptable quality and meet the requirements of this Section.

To check for backscattered radiation, a lead symbol "B", ½ inch high and 1/16 inch thick, shall be attached to the back of each film cassette. If the "B" image appears on the radiograph, the radiograph shall be considered unacceptable.

In general, webs and flanges shall be radiographed before the member is assembled. When, because of some unusual situation, it is necessary to radiograph a member which has already been assembled (a tee conformation), the source shall be placed between the flanges and the film shall be placed against the outside flange surface such that both the flange edge and the web to flange welds are clearly delineated on the film. A similar technique shall be used for radiographing webs of members already assembled.

Edge blocks shall be used when radiographing welds in butt joints greater than $\frac{1}{2}$ inch (12mm) in thickness. The edge blocks shall have a length sufficient to extend beyond each side of the weld centerline for a minimum distance equal to the weld thickness but no less than 2 inches (50mm) and shall have a thickness equal to the thickness of the weld. The minimum width shall be equal to half the weld thickness but no less than 1 inch (25mm). The edge block shall be centered on the weld with a tight fit against the edge of the plate, allowing no more than a $\frac{1}{8}$ inch (3mm) gap. Gaps measured on the film exceeding this dimension shall be rejected and re-radiographed. Edge blocks shall be made of radiographically clean steel and the surface shall have a finish of ANSI 125 (3 μ m) or smoother. For details, see figure 6.2 of AWS D1.5.

Minimum penetrameter thickness	0.005 inch
Minimum diameter for IT hole	0.010 inch
Minimum diameter for 2T hole	0.020 inch
Minimum diameter for 4T hole	0.040 inch

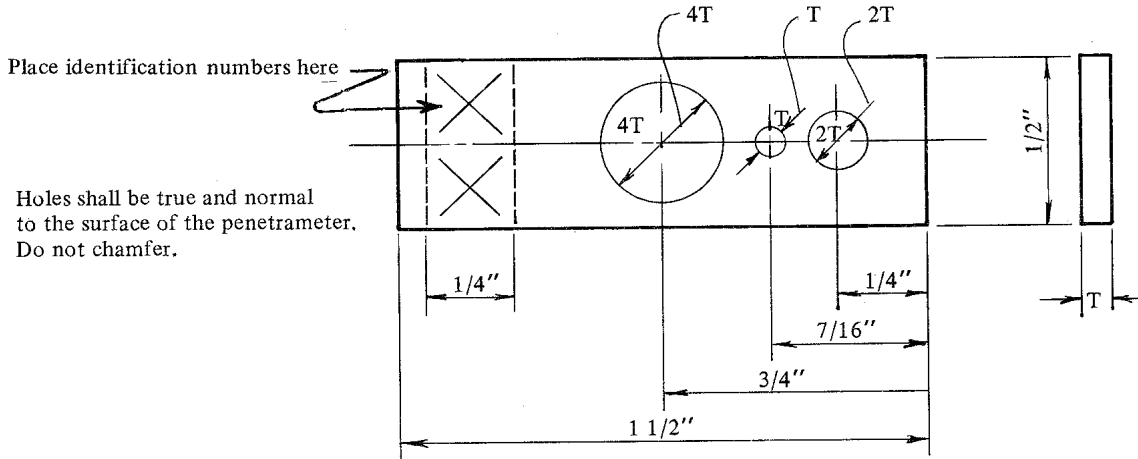

Design for penetrameter thickness from 0.005 inch and including 0.050 inch:
 From 0.005 inch through 0.012 inch, see ASTM E142, Table 1.
 From 0.012 inch through 0.030 inch, made in 0.0025 inch increments.
 From 0.020 inch through 0.050 inch, made in 0.005 inch increments.
 Penetrameter thicknesses between the increments indicated are permitted, provided they do not exceed the maximum thickness required.

FIGURE 1604.2a – PENETRAMEETER DESIGN

Place identification numbers here

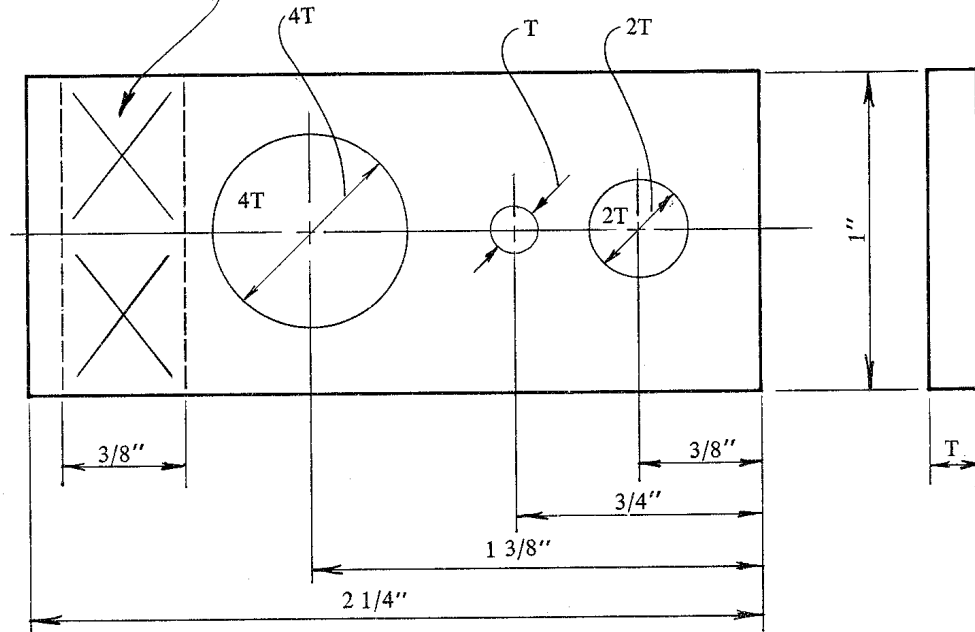

Design for penetrometer thickness from 0.060 inch to 0.160 inclusive made in 0.010 inch increments.

Note:

Tolerances on penetrometer thickness and hole diameter shall be $\pm 10\%$ or one half of the thickness increment between penetrometer sizes, whichever is smaller.

FIGURE 1604.2a- PENETRATOR DESIGN (continued)

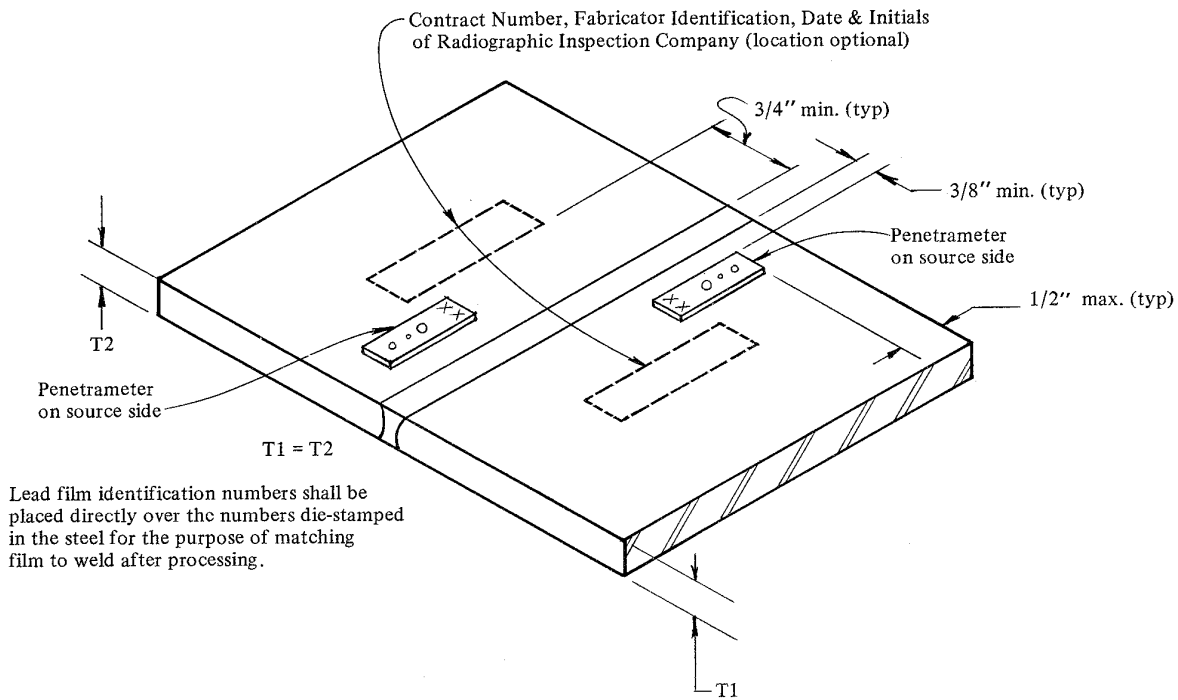

FIGURE 1604.2b –
RADIOGRAPH IDENTIFICATION AND PENETRAMETER LOCATIONS –EQUAL THICKNESS

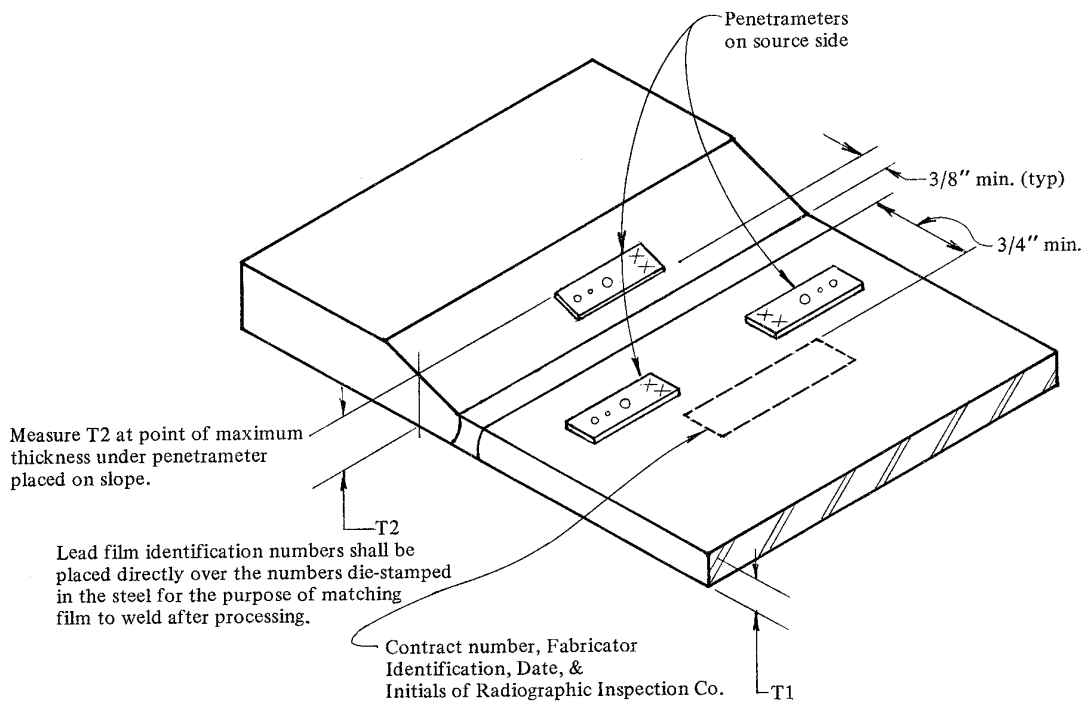

FIGURE 1604.2c –
RADIOGRAPH IDENTIFICATION AND PENETRAMETER LOCATIONS –UNEQUAL THICKNESS

1604.3 Quality of Radiographs. In general, the quality of the radiographs will be determined by the quality of the penetrometer images and freedom from film defects. All radiographs shall be free from mechanical, chemical, or other blemishes that may mask or be confused with the image of any discontinuity in the radiograph. Such blemishes include, but are not limited to:

- a) Fogging and cassette light leaks.
- b) Processing defects such as streaks, water marks, or chemical stains.
- c) Scratches, finger marks, crimps, dirtiness, static marks, smudges, or tears.
- d) Loss of detail due to poor screen to film contact.
- e) False indications due to defective screens or internal faults.

If any of the above blemishes are on the film but outside the area of interest, they shall be noted on the RT report. If any of the above blemishes are on the film in the area of interest, the weld shall be reshot.

1604.4 Density Limitations. Radiographs shall have an H&D density of 1.8 minimum for radiographs made with an X ray source and 2.0 minimum for radiographs made with a gamma ray source. The maximum density shall be 4.0. Densities within the range of 2.5 to 3.5 are preferred for single film viewing.

H&D (radiographic) density is a measure of film blackening, expressed as:

$$D = \log I_0 / I, \text{ where}$$

D = H&D (radiographic) density,

I_0 = light intensity incident on the film, and

I = light intensity transmitted through the film

When transitions in thickness are radiographed where the ratio of the thickness of the thicker section to the thinner section is 3 or greater, radiographs should be exposed to produce a density of 3.0 to 4.0 in the thinner section. When this is done, the minimum density requirements shall be waived in the thicker section. Except for this condition, densities outside the maximum and minimum limits listed above will be cause for rejection of the radiograph. Radiographic density shall not vary by more than 0.50 in any section of equal thickness shown in the radiograph.

1604.5 Film Identification. In order that films may be properly identified for examination, filing and actual physical matching with the steel when required, the following information shall appear on each film:

- a) New York State contract number.
- b) Initials of radiographic inspection company.
- c) Initials of fabricator and the fabricator's shop order number.
- d) Date.
- e) Erection mark.
- f) Weld number and an individual piece mark, in the event that there is a duplication of erection marks on the contract.
- g) Location letters.
- h) Penetrameters.

See Figure 1604.2b & c for details of film identification. All the information described above in this subsection shall appear on each film. The images appearing on the film shall be obtained by placing lead numbers and letters on the steel on the source side prior to exposure. The minimum height of numbers and letters shall be $\frac{5}{16}$ inch. The Contractor will be permitted to preprint the New York State contract number, the initials of the radiographic company, and the fabricator's initials on the radiographs by a direct light process provided that this information is not placed within $\frac{3}{4}$ inch of the edge of the weld. When the direct light preprinting technique is used, the remaining items of film identification listed above shall be produced on the radiograph by the use of lead numbers as

described. The fabricator's shop order number shall be placed on the radiograph by the use of lead numbers.

NOTE: Grease pencils and similar materials shall not be used to mark on radiographs. No identifying mark or notation shall be placed on a radiograph by any procedure that might interfere with the interpretation of the radiograph without prior approval of the DCES.

1604.6 Weld Identification. Individual welds are identified on the film and in the radiographic inspection report based upon weld numbers assigned prior to radiography by numbering the web and flange welds from left to right beginning from the marked end of the erection piece as shown on the shop drawing.

Each weld joint shall be permanently stamped with the identifying erection mark, weld number, piece mark when required, and location letters required by this specification as shown in Figure 1604.6. Low stress stamps, i.e., manufactured to produce impressions that are rounded at the bottom of the impression rather than sharp edged, shall be used.

The stamped numbers and letters shall be $\frac{3}{8}$ inch to $\frac{1}{2}$ inch high. Stamp shall be lightly struck to produce the minimum impression that can be clearly seen in the absence of paint and mill scale.

Lead location letters and weld numbers used to permanently identify the radiographs shall be placed directly over the impressions stamped in the steel prior to radiography. Spacing shall be somewhat random. Templates shall not be used. In general, when radiographs are viewed in register, only those films representing the same joint should have the location letters perfectly superimposed.

Care should be taken to insure that the stamped impressions are not lost during any repair welding or surface preparation that follows radiography. To help insure that the exact center of weld is not lost during the work, at least two center punch marks should be placed 1.00 foot from the center of the weld. These marks may be placed on one or both sides of the weld with one impression 2 inches to 3 inches from each end of the joint.

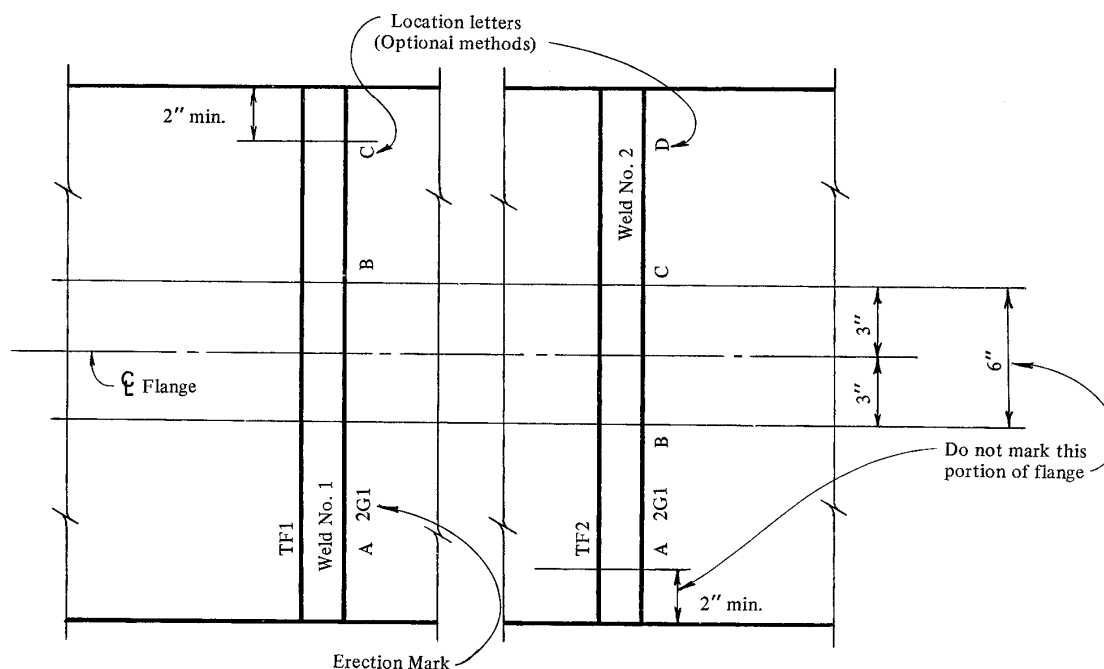

FIGURE 1604.6 – PERMANENT IDENTIFICATION OF BUTT JOINTS

1605. EXAMINATION, REPORT, AND DISPOSITION OF RADIOGRAPHS

1605.1 General. The contractor/fabricator shall provide a suitable variable intensity illuminator (viewer) with spot review or masked spot review capability. The viewer shall incorporate a means for adjusting the size of the spot under examination. The viewer shall have sufficient capacity to properly illuminate radiographs with an H&D density of 4.0. Film review shall be done in an area of subdued light.

1605.2 Standards of Acceptance. Welds subject to radiographic inspection shall have no cracks regardless of the direction of stress or type of structure. Porosity or fusion type discontinuities shall be evaluated by the following criteria.

1605.2.1 Tension Welds in Bridges. The greatest dimension of any porosity or fusion type discontinuity that is $\frac{1}{16}$ inch or larger in greatest dimension shall not exceed the size, "B-Dimension of Discontinuity" indicated in Figure 1605a for the effective throat thickness or weld size inspected. The distance from any porosity or fusion type discontinuity described above to another such discontinuity, to an edge, or to any intersecting weld shall not be less than "C-Minimum Clearance", for the size of discontinuity under examination. When two discontinuities can be measured as a single discontinuity from the extreme limits of the two discontinuities, including the space between them, and the combined length of discontinuity does not exceed the size, "B-Dimension of Discontinuity", for the effective throat thickness or weld size inspected, no repair shall be required.

The limitations given by Figure 1605a for a $\frac{1}{2}$ inch joint or weld throat thickness shall apply to all joints or weld throats of greater thickness. Unless otherwise restricted, the sum of the greatest dimension of porosity and fusion type discontinuities less than $\frac{1}{16}$ inch in greatest dimension shall not exceed $\frac{3}{8}$ inch in any linear inch of weld.

1605.2.2 Compression and Shear Welds in Bridges. The greatest dimension of any porosity or fusion type discontinuity that is $\frac{1}{8}$ inch or larger in greatest dimension shall not exceed the size, "B-Dimension of Discontinuity," indicated in Figure 1605b for the effective throat thickness or weld size inspected. The distance from any porosity or fusion type discontinuity described above to another such discontinuity, to an edge, or to any intersecting weld shall not be less than "C-Minimum Clearance", for the size of discontinuity under examination. When two such discontinuities can be measured as a single discontinuity from the extreme limits of the two discontinuities, including the space between them, and the combined length of discontinuity does not exceed the size, "B-Dimension of Discontinuity," for the effective throat thickness or weld size inspected, no repairs shall be required.

The limitations given by Figure 1605b for $1\frac{1}{2}$ inch joint or weld throat thickness shall apply to all joints or weld throats of greater thickness.

Unless otherwise restricted, the sum of the greatest dimension of porosity and fusion type discontinuities less than $\frac{1}{16}$ inch in greatest dimension shall not exceed $\frac{3}{8}$ inch in any linear inch of weld.

1605.2.3 Welds in Buildings. Porosity or fusion type discontinuities having a greatest dimension of $\frac{3}{32}$ inch or greater shall be unacceptable if they exceed the following limits:

- a) The greatest dimension of the discontinuity is larger than $\frac{2}{3}$ of the effective throat thickness or $\frac{2}{3}$ the weld size or $\frac{3}{4}$ inch.
- b) The discontinuity is closer than three times its greatest dimension to the end of a groove weld subject to tension.
- c) A group of such discontinuities in line when:
 - 1) The sum of the greatest dimensions of all such discontinuities is larger than the effective joint thickness or weld size in any length of six times the effective joint thickness or weld size. When the length of the weld being examined is less than six times the effective thickness or weld size, the permissible sum of the greatest dimensions shall be proportionally less than the effective throat thickness or weld size.
 - 2) The space between two such discontinuities which are adjacent is less than three times the greatest dimension of the larger of the discontinuities in the pair being considered. When two such discontinuities can be measured as a single discontinuity from the extreme limits of the two discontinuities, including the space between them, and the combined discontinuity is still accepted under the provisions specified above, no repair shall be required.
- d) Independent of the requirements of the above paragraphs, discontinuities having a greatest dimension of less than $\frac{3}{32}$ inch are considered unacceptable if the sum of their greatest dimensions exceeds $\frac{3}{8}$ inch in any linear inch of weld.

1605.2.4 Repair of Discontinuities. Welds shown by radiographic testing to have discontinuities prohibited by Sections 1605.2.1 thru 1605.2.3 shall be corrected in accordance with Section 726.

1605.3 Radiographic Reports and Submission of Radiographs. A separate radiographic report will be required for each erection piece. The radiographic report shall be prepared by the company providing radiographic inspection services and will be subject to the review and approval of the Inspector before transmittal to the DCES. Radiographic reports shall conform in general to the example shown in Figure 1605.3. The Radiographic Inspection Report described in Figure 1605.3 has been completed to show the testing and repair of a fairly complex weldment.

A schematic drawing of the complete erection piece shall appear at the top of the sheet and shall show all points of support for the member. The thickness and width or length of all joints shall be shown on the drawings. The required penetrometer designation shall be shown adjacent to the joint. The direction of lettering of web welds shall be shown. Each individual radiograph shall be listed as accepted or rejected. All visible discontinuities shall be explained. No films shall be forwarded to the

State as accepted that contain any indication that could be interpreted as a rejectable discontinuity. The explanation that this is a surface indication is only acceptable under unusual conditions. Surface marks, except the die stamp indications required by the specifications, shall be removed before the joint is radiographed.

All repair welds shall be identified in the report and in the radiograph by the letter "R" following the radiograph identification. The first repair shall be designated "R1," the second "R2," etc.

The radiographs for each erection piece and the radiographic inspection report describing the piece shall remain in the shop or at the site until the last joint in that member has been radiographed and accepted. The repair and acceptance of each joint shall be placed in logical order in the report. When the last joint in the piece is interpreted to be acceptable by the radiographer representing the fabricator, the film and report for that joint shall be submitted to the Inspector for review as required for each day's radiography.

When the Inspector accepts this final joint, one radiograph for each joint represented in the erection piece shall be presented to the Inspector with two copies of the completed radiographic inspection report for submission to the DCES. If the fabricator prefers to mail the radiographs and reports directly to the State after approval by the Inspector, this procedure is acceptable. Films and reports are to be forwarded to the DCES not later than two business days following the QA acceptance of the last joint in that erection piece.

The radiographic inspection report for the last erection piece requiring radiography on each shop order shall be clearly identified as the final report for that shop order.

The State will endeavor to review radiographs promptly as they are received. The State's review and disposition of radiographs and radiographic inspection reports is final. The DCES may reject radiographs and/or reports that have previously been accepted by a radiographic inspection company and approved by an Inspector representing the State. The State assumes no responsibility for the improper interpretation of radiographs or reports by others. Prompt review by the State is designed to prevent the discovery of defects after the steel has been shipped from the plant. However, should the steel be shipped and erected prior to the discovery of rejectable defects, all costs associated with the repair of such defects shall be the responsibility of the Contractor.

The final review provided by the State is designed to monitor the effectiveness of the work performed by the Contractor, radiographer and the shop inspector. At the fabricator option, they may submit a form with the radiographs listing the pieces that will be returned by the State after their review. If not, the radiographs may be considered acceptable unless otherwise notified by the State.

The Contractor (Fabricator) and the Inspector will be notified of all radiographs found unacceptable by the State. Unacceptable radiographs will be retained by the State, together with all subsequent repair radiographs. Radiographs required as a result of films or welds rejected by the DCES shall be submitted separate from other radiographs, and shall be accompanied by a letter that answers all questions raised in the State rejection notice.

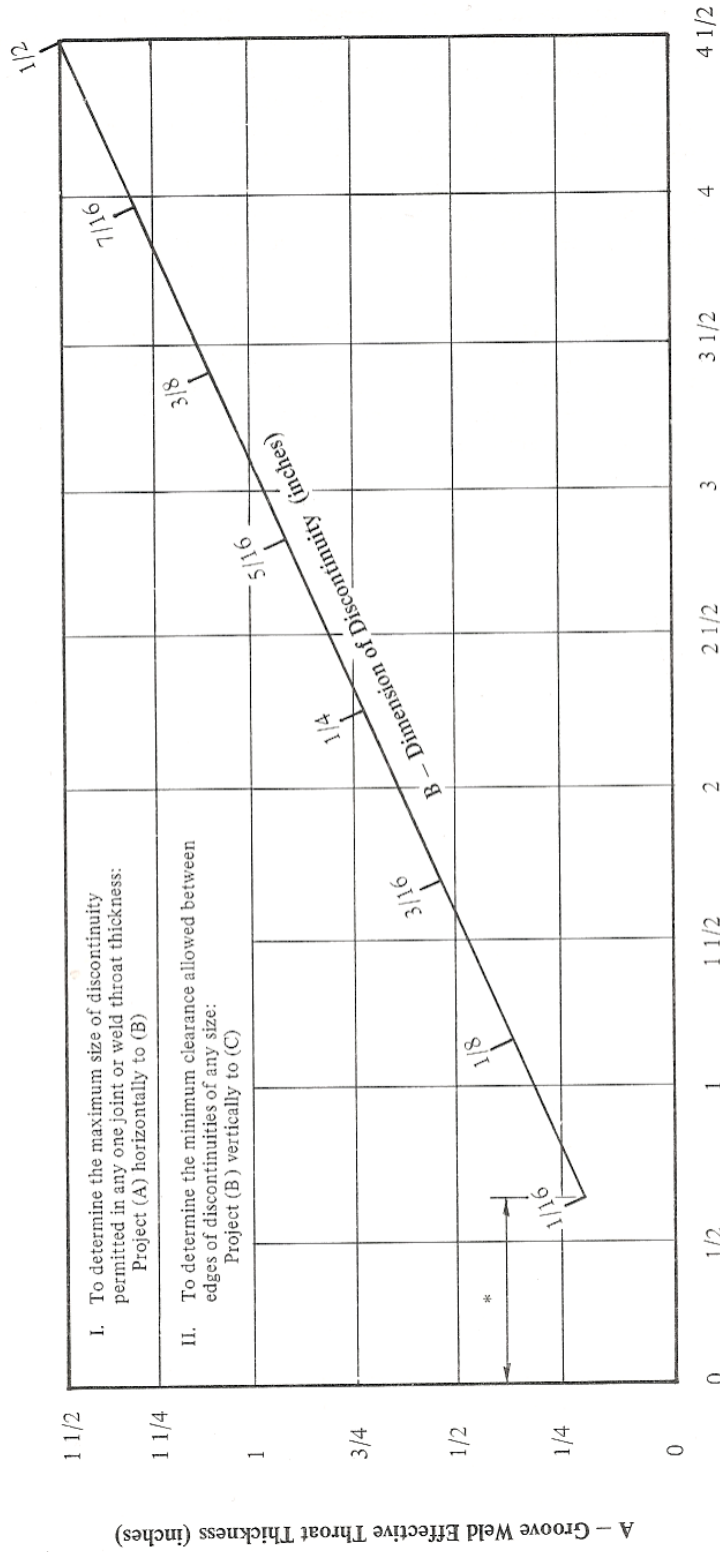

C - Minimum Clearance Measured Along the Longitudinal Axis of the Weld Between Edges of Porosity or Fusion-Type Discontinuities (inches)
(Larger or Adjacent Discontinuities Govern)

*Maximum discontinuity size shall be less than 1/16 inch in this area. Sum of discontinuities shall not exceed 3/16 inch within this distance from the edge or to any intersecting weld.

FIGURE 1605a - LIMITATIONS OF POROSITY AND FUSION TYPE DISCONTINUITIES IN TENSION WELDS - BRIDGES

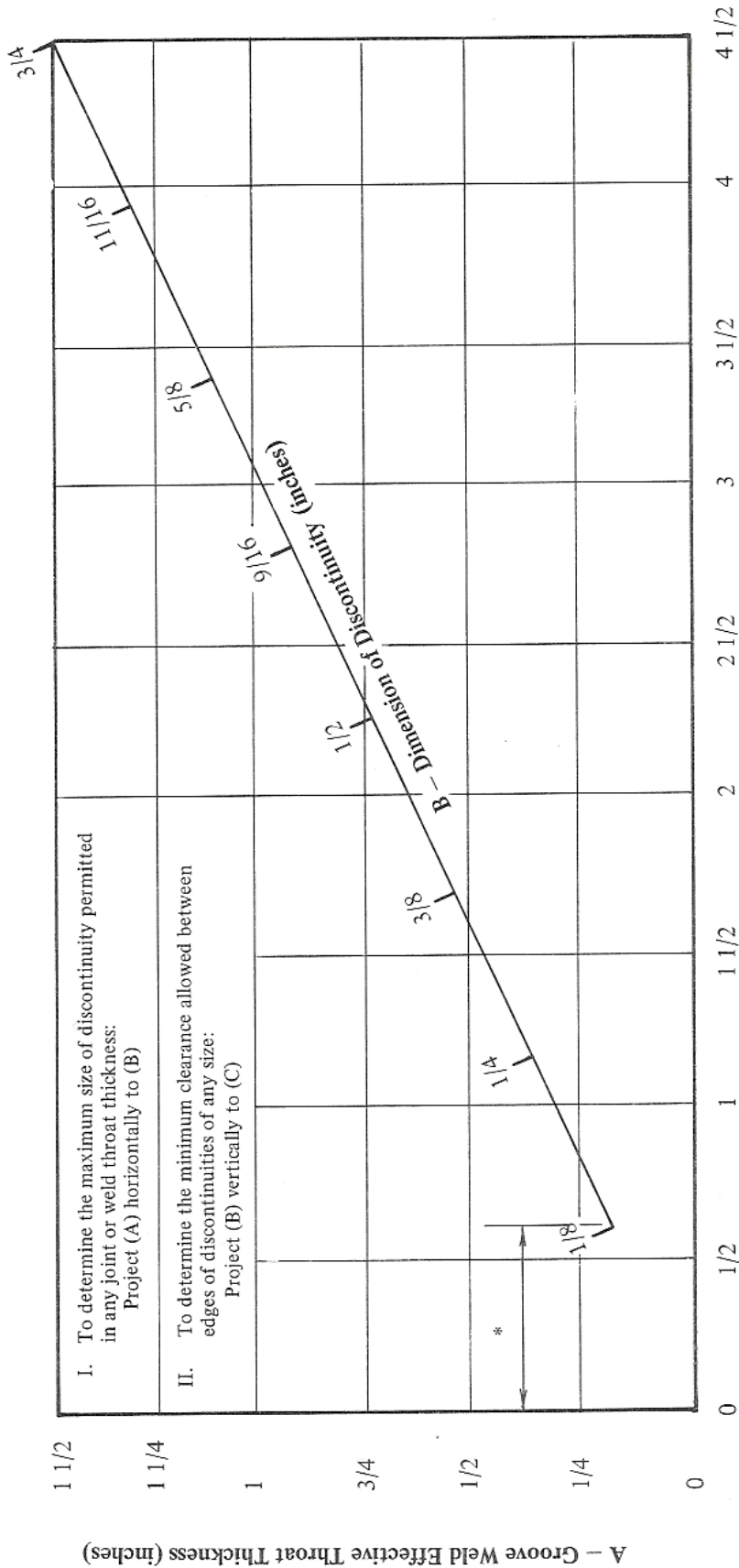

*The maximum size of discontinuities located within this distance from an edge or intersection of a weld shall be 1/8 inch, but a 1/8 inch discontinuity must be 1/4 inch or more away from the edge or intersection. The sum of discontinuities equal to or less than 1/8 inch in size and located within this distance from the edge or intersection shall not exceed 3/16 inch. Discontinuities 1/16 inch to less than 1/8 inch will not be restricted in other locations, unless they are separated by less than 2L (L being the length of the larger discontinuity) in which case the defects shall be measured as one length equal to the total length of the discontinuities and spaces and evaluated by this Figure.

FIGURE 1605b - LIMITATION OF POROSITY AND FUSION TYPE DISCONTINUITIES IN COMPRESSION WELDS-BRIDGES



RADIOGRAPHIC INSPECTION REPORT

Report _____

Sheet _____ of _____

Contract D Project Identification No. _____

Structure _____ County _____

Fabricating Shop _____ Shop Cont. No. _____ Shop Dwg. No. _____

Reported to: New York State Department of Transportation _____

WELD LOCATION AND IDENTIFICATION SKETCH

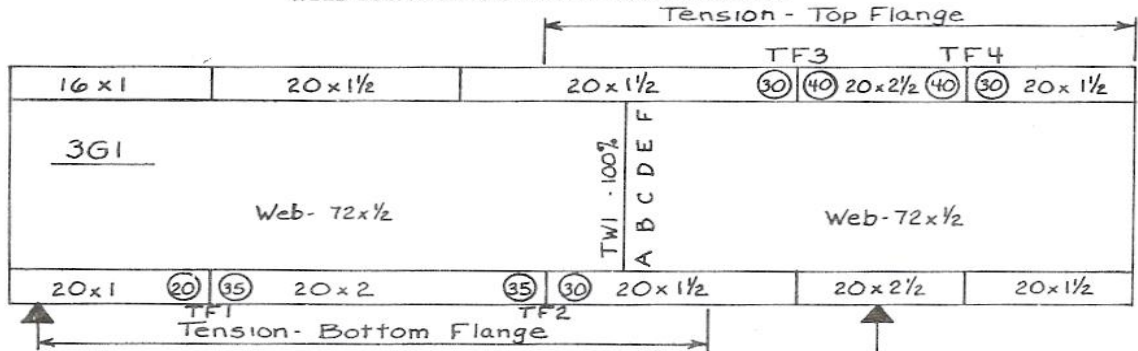

DATE	WELD IDENTIFICATION	AREA	INTERP.		REPAIRS		REMARKS
			ACC.	REJ.	ACC.	REJ.	
4-2-81	TF1	A-B	X				
4-2-81	"	B-C	X				
4-2-81	TF2	A-B		X			Slag - 1" from "A" edge
4-2-81	"	B-C	X				
4-2-81	TF3	A-B	X				
4-2-81	"	B-C		X			Porosity - Edge of plate
4-2-81	TF4	A-B	X				Slag - 1" from "A" within code
4-2-81	"	B-C	X				
4-4-81	TF2-R1	A-B			X		
4-4-81	TF3-R1	B-C				X	Porosity - Edge of plate
4-5-81	TF3-R2	B-C			X		
4-7-81	TW1	A-B	X				
4-7-81	"	B-C	X				
4-7-81	"	C-D	X				
4-7-81	"	D-E	X				
4-7-81	"	E-F	X				

Radiographer _____ Interpreter _____

QA Inspector _____ Date of Final Approval _____

FIGURE 1605.3 – SAMPLE RADIOGRAPHIC INSPECTION REPORT

SECTION 17 ULTRASONIC TESTING

1701. GENERAL

The procedures and standards set forth in this Section shall govern the ultrasonic testing of groove welds between the thicknesses of $\frac{5}{16}$ and 8* inches, inclusive, when such testing is required by the Contract Documents. Provision is also made for base metal soundness tests using straight beam search units.

Variations in testing procedures, equipment and acceptance standards not included in this Section may only be used with the approval of the DCES. Such variations include other thicknesses, weld geometries, search unit (transducer) sizes, frequencies, couplant, etc.

Electrogas and Electroslag welds shall be subject to radiographic inspection in addition to the ultrasonic tests required by the Contract Documents.

1702. EXTENT OF TESTING

Testing shall be performed where and as required by the Contract Documents or as noted in this and other Sections of this Manual. In addition, the following complete penetration welds shall be UT tested as noted:

- a) 100% of all corner and/or "T" joints in tension, and
- b) 25% of each corner and/or "T" joint in compression on each girder or at the Fabricator's option, 25% of the total "T" joints in compression on each girder (with a minimum of testing one complete joint)
- c) 100% of all HPS 70W full penetration joints in tension
- d) 25% of each HPS 70W full penetration joint in compression or at the Fabricator's option 25% of the total full penetration joints in compression on each girder with a minimum of one complete joint.

1703. PERSONNEL QUALIFICATION

Personnel performing ultrasonic testing shall be qualified by written and performance tests administered by the State unless otherwise approved by the DCES. See Appendix P for additional information on the UT Technician Program.

1704. ULTRASONIC EQUIPMENT

1704.1 General. The ultrasonic test instrument shall be the pulse echo type suitable for use with transducers oscillating at the frequency range from one to six megahertz (MHz). The presentation shall be an "A" scan rectified video trace.

Test instruments shall include internal stabilization so that after warm-up, no variation in response greater than ± 1 db occurs with a supply voltage change of 15 percent nominal or, in the case of battery charge, operating life. There shall be an alarm or meter to signal a drop in battery voltage prior to instrument shutoff due to battery exhaustion.

The test instrument shall have a calibrated gain control (attenuator) adjustable in discrete 1 or 2 db steps over a range of at least 60 db. The accuracy of the gain control settings shall be within plus or minus 1 db.

The dynamic range of the instrument's display shall be such that a difference of 1 db of amplitude can be easily detected on the display.

* In bridge construction, this specification only provides for testing in thicknesses of $\frac{5}{16}$ to 6 inches inclusive. Ultrasonic testing of welds in bridges, where the thickness exceeds 6 inches, will be subject to the provisions of a separate individual job specification.

1704.2 Straight Beam Search Units. Straight beam (longitudinal wave) search unit transducers shall have an active area of not less than $\frac{1}{2}$ square inch nor more than 1 square inch. The transducer shall be round or square. Transducer frequency shall be between 2 to 2.5 MHz. Transducers shall be capable of resolving the three reflections as described in Section 1711.1.

1704.3 Angle Beam Search Units. Angle beam (shear wave) search units shall consist of a transducer and an angle wedge. The unit may be comprised of two separate elements or may be an integral unit. The transducer frequency shall be between 2 and 2.5 MHz inclusive. The transducer crystal shall be square or rectangular in shape and may vary from $\frac{5}{8}$ to 1 inch in width and from $\frac{3}{8}$ to $\frac{3}{4}$ inch in height as described in Figure 1704.3a. The ratio of width to height shall be between 1.2 : 1.0 and 1.0 : 1.0.

The search unit shall produce a sound beam in the material being tested within plus or minus 2 degrees of the following proper angles: 70 degrees, 60 degrees, or 45 degrees, as described in Section 1711.2b.

Each search unit shall be marked to clearly indicate the frequency of the transducer, nominal angle of refraction, and index point. The index point location procedure is described in Section 1711.2a.

Maximum allowable internal reflections from the search unit shall be as described in Section 1712.3.

The dimensions of the search unit shall be such that the distance from the leading edge of the search unit to the index line shall not exceed 1 inch. The qualification procedure using the IIW reference block shall be in accordance with Section 1711.2f and as shown in Figure 1704.3b.

The combination of search unit and instrument shall resolve three holes in the resolution test block shown in Figure 1705a. The search unit position is described in Section 1711.2e.

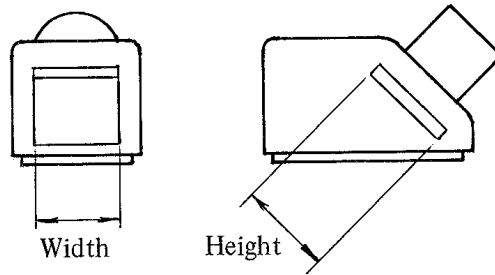

FIGURE 1704.3a – TRANSDUCER CRYSTAL

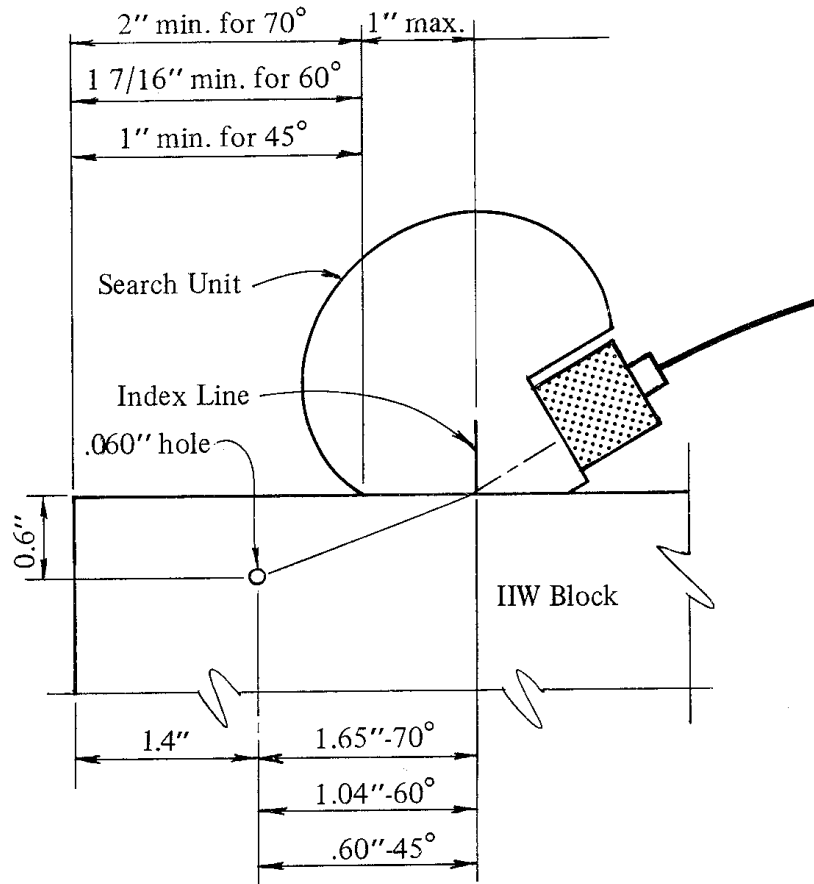

FIGURE 1704.3b – QUALIFICATION PROCEDURE OF SEARCH UNIT USING IIW REFERENCE BLOCK

1705. REFERENCE STANDARDS

The International Institute of Welding (IIW) ultrasonic reference block, shown in Figure 1705a, shall be the standard used for both distance and sensitivity calibration. More portable reference blocks of other designs may be used provided they meet the requirements of this specification and are referenced back to the IIW block. Approved designs are shown in Figure 1705b. See Figure 1711 for applications.

Differences between alternate calibration blocks and the IIW block shall be accounted for in determining the Reference Level and Defect Rating.

The use of a "corner" reflector for calibration purposes is prohibited.

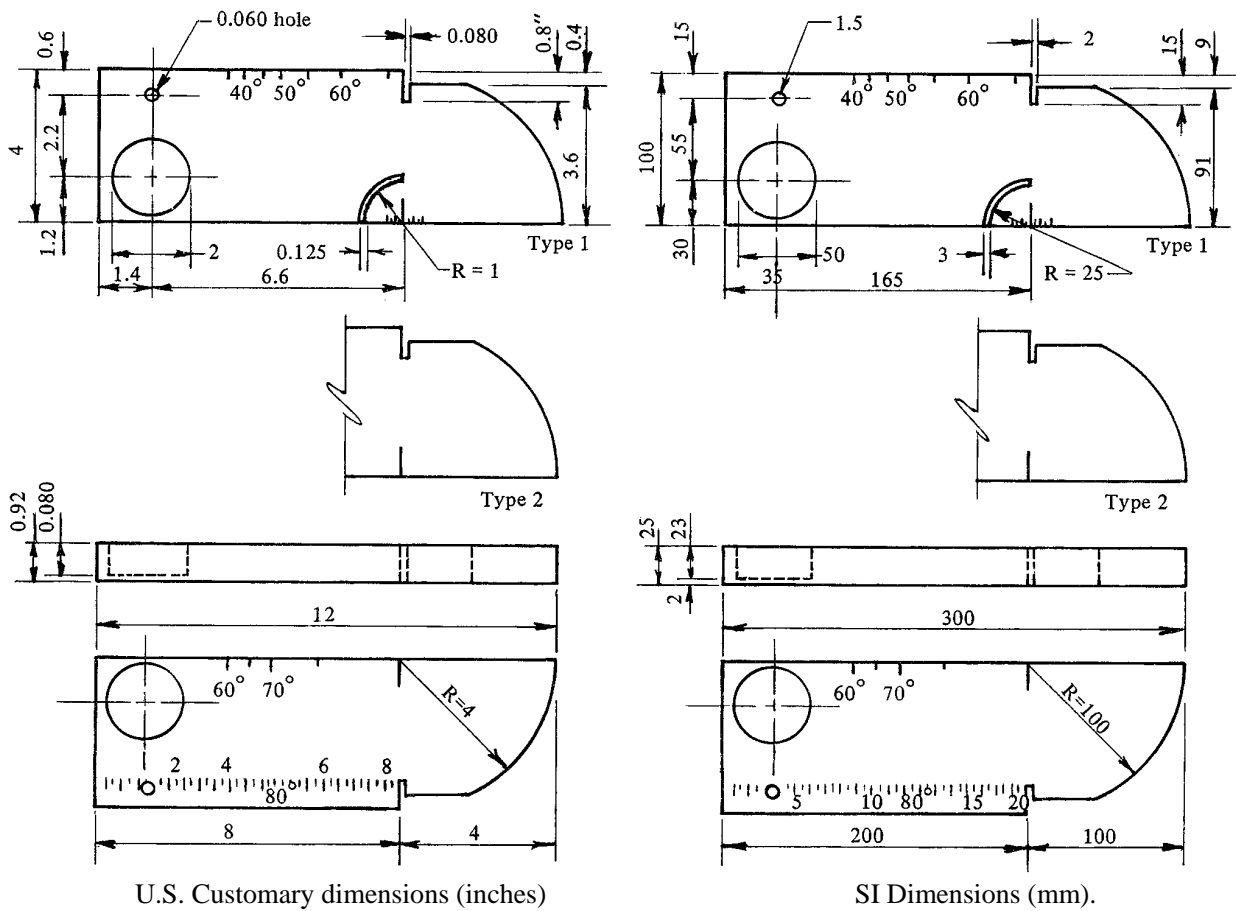

Notes:

1. All dimensions shown shall be accurate to within ± 0.005 inches.
2. Surfaces that transmit or reflect sound shall be machined to produce a surface roughness not greater than 125 microinches.
3. All material shall be ASTM A36 or acoustically equivalent.
4. All holes shall have a smooth internal finish and shall be drilled at 90 degrees to the material surface.
5. Degree lines and identification markings shall be indented into the material surface so that permanent orientation can be maintained.
6. Other IIW approved reference blocks with slightly different dimensions or distance calibration slot features are permissible.

**FIGURE 1705a – INTERNATIONAL INSTITUTE OF WELDING (IIW)
ULTRASONIC REFERENCE BLOCKS**

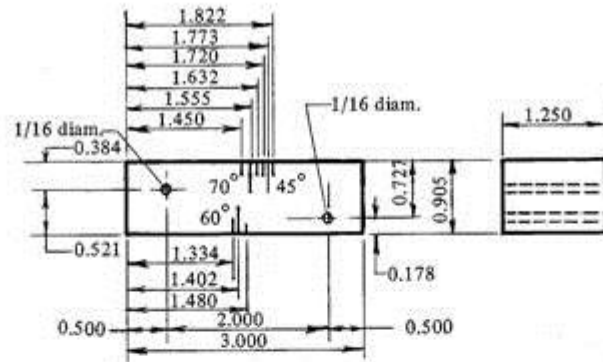

Type SC – Sensitivity calibration block

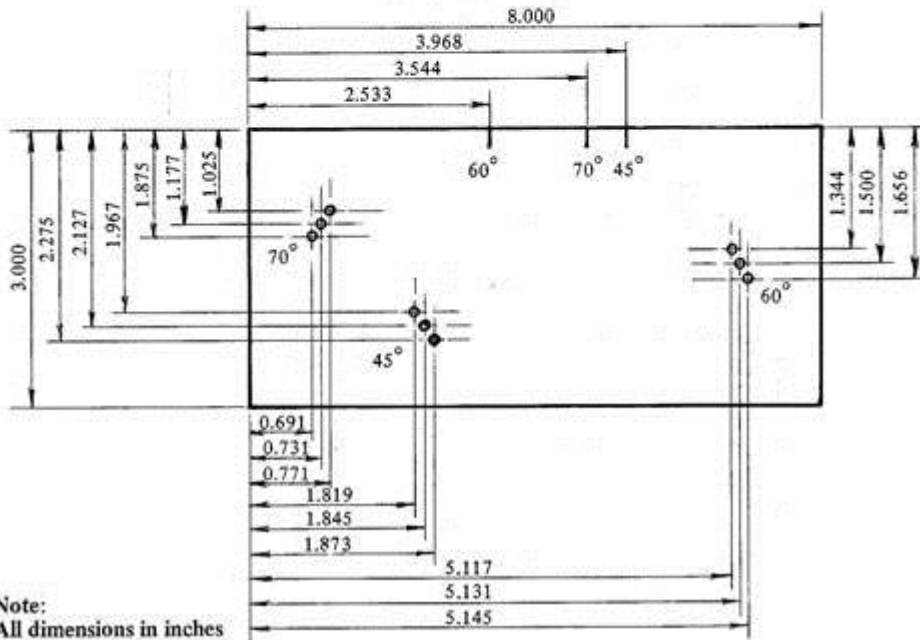

Note:
All dimensions in inches

All holes shall be 1/16 inch diameter

1. All dimensions shown shall be accurate to within ± 0.005 inches.
2. Surfaces that transmit or reflect sound shall be machined to produce a surface roughness not greater than 125 microinches.
3. All material shall be ASTM A36 or acoustically equivalent.
4. All holes shall have a smooth internal finish and shall be drilled at 90 degrees to the material surface.
5. Degree lines and identification markings shall be indented in the material surface so that permanent orientation can be maintained.
6. Other IIW approved reference blocks with slightly different dimensions or distance calibration slot features are permissible.

FIGURE 1705b (continued) - OTHER REFERENCE BLOCKS ~

1706. EQUIPMENT QUALIFICATION

1706.1 Horizontal Linearity. The horizontal linearity of the test instrument shall be requalified after each 40 hours of instrument use in each of the distance ranges that the instrument will be used. The qualification procedure shall be in accordance with Section 1712.1.

1706.2 Calibrated Gain Control. The instrument's gain control (attenuator) shall meet the requirements of Section 1704.1 and shall be checked for correct calibration at two month intervals in accordance with AWS D1.5.

1706.3 Certification. Each ultrasonic unit shall be certified for general operational performance at a minimum time interval of 12 months with a method approved by the instrument manufacturer.

1706.4 Internal Reflections. Maximum internal reflections from each search unit shall be verified at a maximum time interval of 40 hours of instrument use in accordance with Section 1712.3.

1706.5 Search Units. With the use of an approved calibration block, each angle beam search unit shall be checked after each eight hours of use to determine that the contact face is flat, that the sound entry point is correct, and that the beam angle is within the permitted plus or minus 2 degrees tolerance in accordance with Section 1711.2a. Search units which do not meet these requirements shall be corrected or replaced.

1707. CALIBRATION FOR TESTING

1707.1 General. Calibration for sensitivity and horizontal sweep (distance) shall be made by the ultrasonic operator just prior to and at the location of testing of each weld. All calibrations and tests shall be made with the reject (clipping or suppression) control turned off. Recalibration shall be made after a change of operators, each 30 minute maximum time interval, or when the electrical circuitry is disturbed in any way which includes the following:

- a) Transducer change
- b) Battery change
- c) Electrical outlet change
- d) Coaxial cable change

The sound path distance shall be measured as the distance to the point where the left side of the trace deflection breaks the base line.

1707.2 Calibration for Straight Beam Testing. Calibration for straight beam testing shall be performed as follows:

- a) Horizontal Sweep. The horizontal sweep shall be adjusted on an approved calibration block to represent the equivalent of at least two plate thicknesses on the CRT screen. The search unit position is described in Section 1711.1
- b) Sensitivity. The sensitivity shall be adjusted on the base metal at a location free of indications so that the first back reflection from the far side of the plate will be 50 to 75% of full screen height.

1707.3 Calibration for Angle Beam Testing. Calibration for angle beam testing shall be performed as follows:

- a) Horizontal Sweep. The horizontal sweep shall be adjusted on an approved calibration block to represent the actual sound path distance by using acceptable distance calibration blocks shown in figures 1705a and 1705b. The distance calibration shall be made using either the 5 inch scale or 10 inch scale on the CRT screen, whichever is appropriate, unless joint configuration or thickness prevents full examination of the weld at either of these settings, in which case the distance calibration shall be made using the 15 or 20 inch scale, as required. The search unit position is described in Section 1711.2c.
- b) Sensitivity. The sensitivity shall be adjusted by the use of the gain control (attenuator) so that a horizontal reference level trace deflection results on the CRT screen from the

maximum indication of the 0.06 inch diameter hole in the IIW block or from the equivalent reference reflector in other acceptable calibration blocks. The search unit position is described in Section 1711.2d. This basic sensitivity then becomes the zero reference level for discontinuity evaluation, and shall be recorded on the ultrasonic test reports under 'Reference Level,' "b," Figure 1709.

1708. TESTING PROCEDURES

1708.1 General. A line shall be marked on Face A of the weldment representing the X axis of the weld joint. The X axis shall be located as described in Table 1700A.

A "Y" accompanied with a weld identification number shall be clearly marked on Face A of the base metal adjacent to the weld at the left end or top of each weld that is ultrasonically tested.

This marking is used for the following purposes:

- a) Weld identification.
- b) Identification of Face A.
- c) Distance measurements and direction (+ or -) from the X axis.
- d) Location measurement from weld ends or edges to the closest edge of the discontinuity.

1708.2 Cleaning. All surfaces to which a search unit is applied shall be free of weld spatter, dirt, grease, oil (other than that used as a couplant), paint, and loose scale and shall have a contour permitting intimate coupling.

1708.3 Couplant. A couplant shall be used between the search unit and the test material. The couplant shall be either glycerin or cellulose gum and water mixture of suitable consistency. A wetting agent may be added if needed. Light machine oil may be used for couplant on calibration blocks. Tests shall verify that the couplant used during calibration produces the same sensitivity as the couplant used during testing. Any variation shall be compensated for as approved by the DCES.

1708.4 Testing with Straight Beam Search Units.

- a) Methods of Tests.
 - 1) Amplitude Method. The instrument shall be adjusted as described in Section 1707.2. The amplitude of the first back reflection shall be recorded as the reference level. No further adjustments of the instrument will be allowed. All discontinuities that produce an indication on the display which equal or exceed the reference level indication shall be rejected.
 - 2) Total Loss of Back Reflection Method. The instrument shall be adjusted as described in Section 1707.2. With no further adjustment to the instrument, the specified area of the base metal shall be searched for laminations. Any area found to exhibit total loss of back reflection shall be rejected. When the defect is located at the mid-thickness of the plate, total loss of back reflection shall be indicated on the screen when the multiple echoes from the defect are found to have a normal decay pattern.
- b) Lamination Test Prior to Weld Test. The entire base metal through which ultrasound must travel to test the weld shall be tested for laminar reflectors with a straight beam search unit conforming to the requirements of Section 1704.2 using the Amplitude Method. If any area of base metal is considered rejectable by this test and is located in a position that would interfere with the normal weld scanning procedure, the following alternate weld scanning procedure shall be used:
 - 1) Determine the area of the laminar reflector, its depth from the surface, and record the data in the ultrasonic test report.
 - 2) Grind both faces of the weld flush if necessary to attain full ultrasonic coverage.
 - 3) Using the applicable scanning pattern shown in Figure 1714, examine the inaccessible part of the weld by testing from both faces in order to attain full weld evaluation.
- c) Laminations Adjacent to Tension Groove Welds. If laminar defects are found by visual or nondestructive tests adjacent to tension groove welds, the base metal shall be tested for soundness in accordance with the following procedure:

- 1) The end 6 inches of the plate or shape adjacent to the tension groove weld shall be divided into two equal areas for testing. Each area shall be 3 inches wide in the direction of the length of the plate or shape, and shall extend for the full width of the section.
- 2) The instrument shall be calibrated in accordance with Section 1707.2 using a straight beam search unit conforming to the requirements of Section 1704.2. The scanning patterns shall overlap to insure 100% inspection. The end 6 inches of the plate or shape shall be tested by the Total Loss of Back Reflection Method. Any lamination found to be rejectable by this test shall cause the rejection of the steel for use adjacent to a tension groove weld.
- 3) If rejectable defects are not discovered by the Total Loss of Back Reflection Method, the end 3 inch wide strip adjacent to the tension groove weld shall be retested using the Amplitude Method. Any lamination found rejectable by this test shall cause rejection of the steel for use adjacent to a tension groove weld.
- 4) The steel shall be rejected for use adjacent to tension groove welds if the results of the magnetic particle inspection reveals defects in excess of the limits described in Section 505.2.

1708.5 Testing With Angle Beam Search Units.

- a) General. Welds shall be tested using an angle beam search unit conforming to the requirements of Section 1704.3 with the instrument calibrated in accordance with Section 1707.3 using the angle as shown in Table 1700A. Following calibration and during testing, the only instrument adjustment permitted is the sensitivity level adjustment with the calibrated gain control or attenuator. Sensitivity shall be increased from the reference level for weld scanning in accordance with Table 1700B for Bridges and Table 1700C for Buildings.
- b) Testing Angle and Scanning Procedure. The testing angle and scanning procedure shall be in accordance with the requirements of Table 1700A. Note that Table 1700A requires testing from Faces A and B under certain conditions. All butt welds shall be tested from each side of the weld axis. Corner and "T" welds shall be primarily tested from one side of the weld axis only. All welds shall be tested using the applicable scanning pattern or patterns shown in Figure 1714 as necessary to detect both longitudinal and transverse flaws.
- c) Indication Level. When a discontinuity indication appears on the screen, the maximum attainable indication from the discontinuity shall be adjusted to produce a horizontal reference level trace deflection on the CRT screen. This adjustment shall be made with the calibrated gain control or attenuator, and the instrument reading in decibels shall be used as the Indication Level, "a," for calculating the Indication Rating, "d," as shown on the test report.
- d) Attenuation Factor. The Attenuation Factor, "c," on the test report is attained by subtracting 1 inch from the sound path distance and multiplying the remainder by two. This factor shall be rounded out to the nearest db value. Fractional values less than ½ db shall be reduced to the lower db level and those of ½ or greater increased to the higher level.
- e) Indication Rating. The Indication Rating "d" in the UT Report represents the algebraic difference in decibels between the Indication Level and the Reference Level with correction for attenuation as indicated in the following expressions:

Instruments with gain in db:

$$a - b - c = d$$

Instruments with attenuation in db:

$$b - a - c = d$$

- f) Defect Length. The length of flaws shall be determined in accordance with the procedure described in Section 1713.2.
- g) Acceptance Criteria. Each weld discontinuity shall be accepted or rejected on the basis of its indication rating and its length, in accordance with Table 1700B for bridges (Tension), or Table 1700C for buildings (Compression), whichever is applicable. Complete joint penetration web to flange welds shall conform to the requirements of Table 1700B for tension areas and Table 1700C for compression areas.

- h) Defect Location. Each rejectable discontinuity shall be indicated on the weld by a mark directly over the discontinuity for its entire length. The depth from the surface and type of discontinuity shall be noted on nearby base metal.
- i) Repairs. Welds found unacceptable by ultrasonic testing shall be repaired by methods permitted by Section 726. Repaired areas shall be retested ultrasonically.

1709. PREPARATION AND DISPOSITION OF REPORTS

A report form which clearly identifies the work and the area of inspection shall be completed by the ultrasonic technician at the time of inspection. The report form for welds shall contain sufficient information to identify the weld, the inspector (signature), and the disposition of the weld. An example of such a form is shown in Figure 1709.

All rejectable discontinuities shall be recorded in the test report. Other discontinuities shall be recorded if the Indication Rating is + 10db or less for bridges, or + 6db or less for buildings. Repaired and retested welds shall be recorded on the original or a continuation of the original report form.

A full set of completed report forms of welds subject to ultrasonic testing by the Contractor/Fabricator, including any that show unacceptable quality prior to repair, shall be forwarded to the Metals Engineering Unit within 2 work days of the joint being accepted. The contractor's obligation to retain ultrasonic reports shall cease upon delivery of this full set of reports to the State.

1710. WITNESSING OF ULTRASONIC TESTS

All ultrasonic tests required by the Contract Documents that are not performed by State forces or by an inspection agency under contract to the State shall be witnessed by a representative of the State.

1711. CALIBRATION OF THE ULTRASONIC UNIT WITH THE IIW OR OTHER APPROVED REFERENCE BLOCKS (See Figure 1711

1711.1 Longitudinal Mode.

- a) Distance Calibration.
 - 1) Set the transducer in position G on the IIW block, position H on the DC block, or position M on the DSC block.
 - 2) Adjust instrument to produce indications at 1 inch (25.4 mm), 2 inches (50.8 mm), 3 inches (76.2 mm), 4 inches (101.4 mm), etc., on the display.
- b) Amplitude.
 - 1) Set the transducer in position G on the IIW block, position H on the DC block, or position M on the DSC block, or as described in Section 1707.2.
 - 2) Adjust the gain until the maximized indication from the first back reflection attains 50 to 75 percent screen height.
- c) Resolution. Set the transducer in position F on the IIW block. Transducer and instrument should resolve all three distances.
- d) Horizontal Linearity Qualification. The procedure shall be in accordance with Sections 1706.1 and 1712.1.
- e) Gain Control or Attenuation Qualification. The procedure shall be in accordance with AWS DI.5.

1711.2 Shear Wave Mode (Transverse)

- a) Sound Entry Point. Locate or check the transducer sound entry point (index point) by the following procedure:
 - 1) Set the transducer in position D on the IIW block, position J or L on the DSC block, or I on the DC block.
 - 2) Move the transducer until the signal from the radius is maximized. The point on the transducer which is in line with the line on the calibration block is indicative of the point of sound entry.
- b) Sound Path Angle. Check or determine the transducer sound path angle by the following procedure:
 - 1) Set the transducer in position B on the IIW block for angles 40 degrees through 60 degrees.
 - 2) Set the transducer in position C on the IIW block for angles 60 degrees through 70 degrees.
 - 3) Set the transducer in position K on the DSC block for angles 45 degrees through 70 degrees.
 - 4) Set the transducer in position N on the SC block for 70 degree angle.
 - 5) Set the transducer in position O on the SC block for 45 degree angle.
 - 6) Set the transducer in position P on the SC block for 60 degree angle.
 - 7) Move the transducer back and forth over the line indicative of the transducer angle until the signal from the radius is maximized. Compare the sound entry point on the transducer with the angle mark on the calibration block (tolerance ± 2 degrees).
- c) Distance Calibration Procedure.
 - 1) Set the transducer in position D on the IIW block for any angle.
 - 2) Adjust the instrument to attain indications on the display at 4 inches (101.4 mm) and 8 inches (203.2 mm) on the Type 2 block or 9 inches (228.6 mm) on the Type 1 block.
 - 3) Set the transducer in position J or L on the DSC block for any angle.
 - 4) Adjust the instrument to attain indications at 1 inch (25.4 mm), 5 inches (127 mm) and 9 inches (230 mm) on the display in the L position.
 - 5) Adjust the instrument to attain indications at 3 inches (76.2mm), and 7 inches (177.8) on the display in the L position.
 - 6) Set the transducer in position I on the DC block for any angle.
 - 7) Adjust the instrument to attain indications at 1 inch (25.4 mm), 2 inches (50.8 mm), 3 inches (76.2 mm), 4 inches (101.4 mm), etc. on the display.

- d) Amplitude or Sensitivity Calibration Procedure.
- 1) Set the transducer in position A on the IIW block for any angle.
 - 2) Adjust the maximized signal from the 0.06 inch hole to attain a horizontal reference line height indication.
 - 3) Set the transducer in position L on the DSC block for any angle.
 - 4) Adjust the maximized signal from the $\frac{1}{32}$ inch slot to attain a horizontal reference line height indication.
 - 5) Set the transducer on the SC block in position N for 70 degree angle, position O for 45 degree angle, or position P for 60 degree angle.
 - 6) Adjust the maximized signal from the $\frac{1}{16}$ inch hole to attain a horizontal reference line height indication.
 - 7) The decibel reading obtained in 2) shall be used as the "Reference Level" "b" reading on the Test Report sheet.
- e) Resolution.
- 1) Set the transducer on the resolution block, position Q for 70 degree angle, position R for 60 degree angle, or position S for 45 degree angle.
 - 2) Transducer and instrument shall resolve the three test holes, at least to the extent of distinguishing the peaks of the indications from the three holes when the instrument controls are set at normal test settings.
- f) Approach Distance of Search Unit. The minimum allowable distance, X, between the toe of the search unit and the edge of IIW block shall be as follows and as described in Figure 1704.3b.
- 1) for 70 degrees transducer, X = 2 inches.
 - 2) for 60 degree transducer, X = $1\frac{7}{16}$ inches.
 - 3) for 45 degree transducer, X = 1 inch.

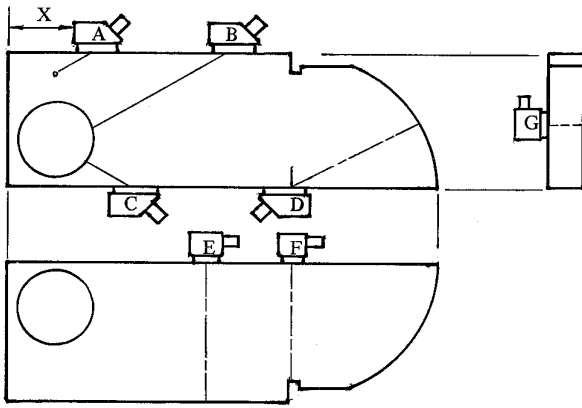

IIW block

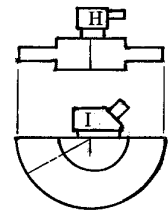

DC block

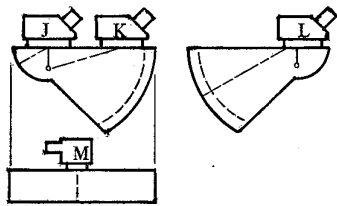

DSC block

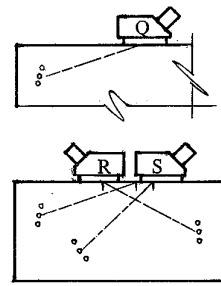

Resolution block

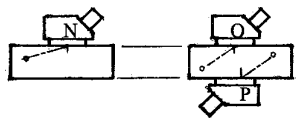

SC block

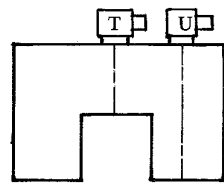

DS block

FIGURE 1711 – TRANSDUCER POSITIONS

1712. EQUIPMENT QUALIFICATION PROCEDURES

1712.1 Horizontal Linearity Procedure. Since this qualification procedure is performed with a straight beam search unit which produces a longitudinal wave with a sound velocity of almost double that of a shear wave, it is necessary to double the shear wave distance ranges to be used in applying this procedure. Example: The use of a 10 inch screen calibration in shear wave would require a 20 inch screen calibration for this qualification procedure. The following procedure shall be used for instrument certification:

- 1) Couple a straight beam search unit meeting the requirements of Section 1704.2 to the IIW, DSC, DC or DS block in Position G, H, M, T, or U, Figure 1711, as necessary to attain 5 back reflections in the range being certified.
- 2) Adjust the first and fifth back reflections to their proper locations with the use of the distance calibration and zero delay adjustments.
- 3) Each indication shall be adjusted to reference level with the gain or attenuation control.

Each intermediate trace deflection location shall be correct within $\pm 2\%$ of the screen width.

1712.2 Vertical Linearity Procedure. The vertical linearity of the test instrument shall be calibrated by a procedure approved by the DCES.

1712.3 Internal Reflections Procedure.

- 1) Calibrate the equipment in accordance with Section 1707.
- 2) Remove the search unit from the calibration block without changing any other equipment adjustments.
- 3) Increase the calibrated gain or attenuation 20 db more sensitive than reference level.
- 4) The display screen area beyond $\frac{1}{2}$ inch sound path and above the reference level height shall be free of any indication.

1713. FLAW SIZE EVALUATION PROCEDURES

1713.1 Straight Beam Testing. When the discontinuity is larger than the transducer, full loss of back reflections may be produced when probing directly over the flaw. The boundaries of the discontinuity shall be determined by locating the points on the steel at the center line of the search unit where the indication amplitude drops 6 db.

The approximate size of discontinuities which are smaller than the transducer shall be determined by beginning outside the discontinuity and moving the transducer toward the area of the discontinuity until an indication on the display begins to form. The leading edge of the search unit at this point is indicative of the edge of the discontinuity.

The ultrasonic equipment shall be calibrated in accordance with Section 1707.2 during the above tests.

1713.2 Angle Beam Testing. The length of a discontinuity shall be determined by locating the points on the steel, projected from the centerline of the search unit, where the indication amplitude drops or raises 6 db, and measuring between these points. Contiguous discontinuities with defect ratings that vary by more than six decibels shall be recorded as separate discontinuities. The measured length of each discontinuity shall be entered under "Indication Length" on the test report, Figure 1709-

When evaluating certain large cracks or other planar discontinuities, the test instrument may respond to individual facets of the flaw rather than accurately responding to all of the reflective area within the sound beam. Flaws that are found to be acceptable in accordance with Tables 1700B and 1700C, but produce a signal response of measurable amplitude when the search unit is moved forward and backward in accordance with scanning movement B, Figure 1714, shall be rejected by the ultrasonic technician and reported to the DCES for final determination.

1714. SCANNING PATTERNS

1714. SCANNING PATTERNS

Scanning patterns shall be as described in Figure 1714.

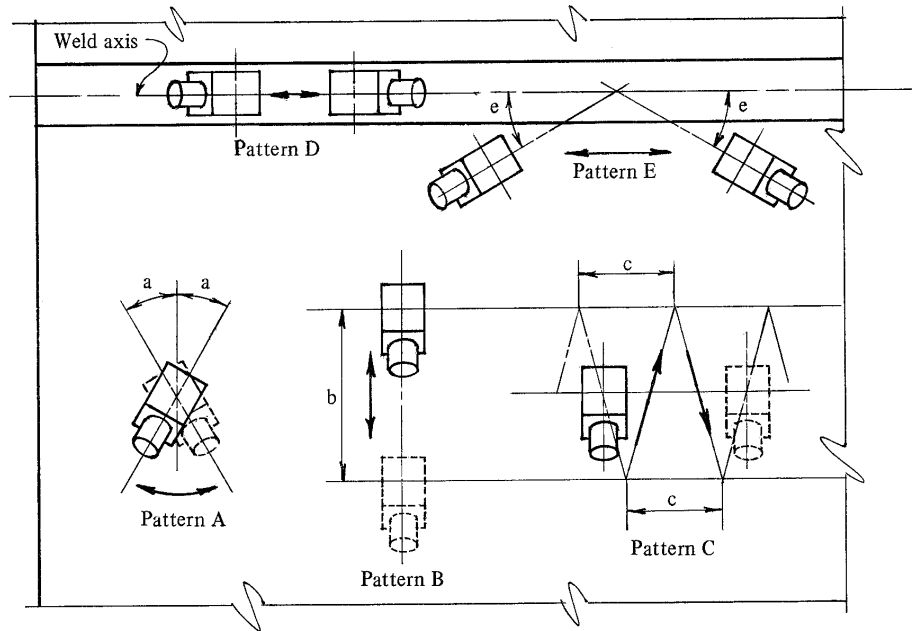

Notes:

1. Testing patterns are all symmetrical around the weld axis with the exception of pattern D which is conducted directly over the weld axis.
2. Testing from both sides of the weld axis is to be made wherever mechanically possible.

Plan View of Welded Plate

Scanning for Longitudinal Discontinuities.

- a) Scanning Pattern A. Rotation angle $a = 10$ degrees.
- b) Scanning Pattern B. Scanning distance b shall be such that the full section of weld being tested is covered.
- c) Scanning Pattern C. Progression distance c shall be approximately one-half the transducer width.

Note: Patterns A, B and C are combined into one scanning pattern.

Scanning for Transverse Discontinuities.

- a) Use scanning pattern D when weld reinforcement is ground flush.
- b) Use scanning pattern E when weld reinforcement is not ground flush. Scanning angle $e = 15$ degrees maximum.

Note: The scanning pattern is to be such that the full weld section is covered.

Electroslag or Electrode Gas Welds.

- a) The search unit rotation angle e shall be between 45 degrees and 60 degrees.

Note: The scanning pattern shall be such that the full weld section is covered. ~

FIGURE 1714 – SCANNING PATTERNS

TABLE 1700A PROCEDURE CHART

PROCEDURE CHART																							
Weld Type	Weld or Material Thickness																						
	5/16 to 1/2		>1/2 to 1		>1 to 1 1/2		>1 1/2 to 1 3/4		>1 3/4 to 2 1/2		>2 1/2 to 3 1/2		>3 1/2 to 4 1/2		>4 1/2 to 5		>5 to 6 1/2		>6 1/2 to 7		>7 to 8		
		*		*		*		*		*		*		*		*		*		*		*	
Butt	1a	0	1b	0	1c	F	2	F	2** or 3	F	2** or 3**	F	4	F	5** or 4**	F	6** or 5**	F	6** or 7	F	9**	F	
Tee	1d or 1e	0	1d or 1e	0	1c	F or XF	2	F or XF	2** or 3	F or XF	2** or 3**	F or XF	4	F or XF	5** or 4**	F or XF	6** or 5**	F or XF	6** or 7**	F or XF	-	-	
Corner	1d or 1e	0	1d or 1e	0	1c	F or XF	2	F or XF	2** or 3	F or XF	2** or 3**	F or XF	4	F or XF	5** or 4**	F or XF	6** or 5**	F or XF	6** or 7**	F or XF	-	-	
Electrogas & Electroslag	1a and RT	0	1b and RT	0	1c and RT	0	2 and RT	0	2** or 3 and RT	0	2** or 3** and RT	0	8** and RT	0	8** and RT	0	8** and RT	0	9** and RT	0	9** and RT	0	

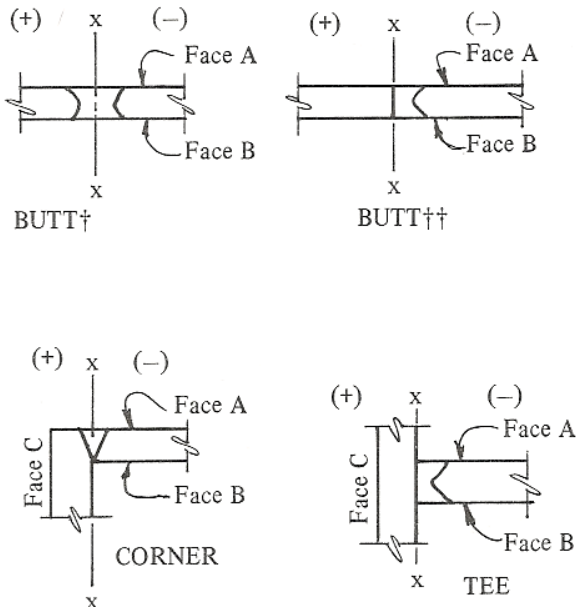

PROCEDURE LEGEND			
NO.	Area of Weld Thickness		
	TOP QUARTER	MIDDLE HALF	BOTTOM QUARTER
1a	70° I and II	70° I and II	70° I and II
1b	70° I and II	70° I and II	70°
1c	70° I and II	70°	70°
1d	70° I and II AB	70° I and II AB	70° I and II AB
1e	70° I, II and III	70° I, II and III	70° I, II and III
2	70° + 60° II	70°	70°
3	70° + 45° II	70°	70°
4	60° B	70°	60°
5	60° B	60°	60°
6	45° B	70°	45°
7	45° B	45°	45°
8	70° B	70° A B	70° A
9	70° GA+60° B	70° A B	60° A+70° GB

TABLE 1700A (continued)

LEGEND

- X Check from Face "c"
- G Grind Weld Face Flush
- O Not Required
- RT Radiographic Inspection
- I Examine weld in Leg I
- II Examine weld in Leg II
- III Examine weld in Leg III
- F Further evaluate fusion boundary indications with either 70°, 60° or 45° transducer, whichever sound path is nearest to being perpendicular to the suspected fusion surface.
- * Required only where reference level indication of defect is noted in fusion zone while searching at scanning level with primary procedure selected from first column.
- ** Use 15 or 20 inch screen distance calibration (the smaller value) as necessary to permit testing of the complete weld and adjacent heat-affected zones using the search unit required by the Procedure Legend.
- t Applies to single vee, double vee, single "U," double "u" and square groove welds.
- tt Applies to single bevel, double bevel, single "J" and double "J" groove welds.
- "A" Face The face of the material from which the initial scanning is done.
- "B" Face Opposite the "A" Face.
- "C" Face The face opposite the weld on the connecting member on Tee or Corner joints.

NOTES:

1. All examinations are to be made from Face "A" except as noted in the Procedure Legend and scanned from both sides of the weld on Face "A" or Face "A" and Face "B" as indicated, where physically possible.
2. Unless otherwise indicated by the Procedure Legend, all tests are to be performed in Leg I. Leg II is specified in some cases to avoid testing in the first inch of the sound path. Leg III may only be used when required by the Procedure Legend or approved by the DCES.
3. Face "A" on both connecting members at a butt weld must lie in a single plane. Should neither Face "A" nor Face "B" of a Butt Weld lie in a single plane, the testing procedure will be subject to the approval of the DCES.

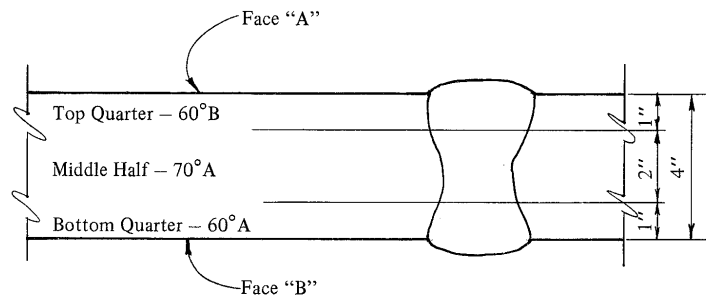

**EXAMPLE: Butt Weld in 4" Material
Procedure No. 4**

TABLE 1700B – HIGHWAY & RAILWAY BRIDGES (TENSION)
Ultrasonic acceptance-rejection criteria

Flaw severity class	Weld thickness and search unit angle										
	5/16 to 3/4	>3/4 to 1 1/2	> 1 1/2 to 2 1/2			> 2 1/2 to 4			> 4 to 8		
	70°	70°	70°	60° *	45° *	70°	60° *	45° *	70°	60° *	45° *
Class A	+10 & lower	+8 & lower	+5 & lower	+8 & lower	+10 & lower	+3 & lower	+6 & lower	+8 & lower	as determined by the DCES		
Class B	+11	+9	+6 +7	+9 +10	+11 +12	+4 +5	+7 +8	+9 +10	as determined by the DCES		
Class C	+12	+10	+8 +9	+11 +12	+13 +14	+6 +7 +8 +9	+9 +10 +11 +12	+11 +12 +13 +14	as determined by the DCES		
Class D	+13 & up	+11 & up	+10 & up	+13 & up	+15 & up	+10 & up	+13 & up	+15 & up	as determined by the DCES		

NOTES:

1. Class Band C flaws shall be separated by at least 2L, L being the length of the longer flaw, except that when two or more such flaws are not separated by at least 2L, but the combined length of flaws and their separation distance is equal to or less than the maximum allowable length under the provisions of Class B or C, the flaw shall be considered a single acceptable flaw.
2. Class Band C flaws shall not begin at a distance less than 2L from the end of the weld or from any intersection weld, L being the flaw length.
3. Flaws detected at "scanning level" in the root face area of complete penetration double vee, double "J", double "O", and double bevel groove weld joints shall be evaluated using an indication rating 4 db more sensitive than that described in this table, i.e., add +4 db to the values in this table.

Class A (large flaws)

Any indication in this category shall be rejected (regardless of length).

Class B (medium flaws)

Any indication in this category having a length greater than ¾ shall be rejected.

Class C (small flaws)

Any indication in this category having a length greater than 2 inches in the middle half or ¾ inch length in the top or bottom quarter of weld thickness shall be rejected.

Class D (minor flaws)

Any indication in this category shall be accepted regardless of length or location in the weld.

Scanning levels

Sound path, inches**	Above zero reference, db
To 2 ½	+20
> 2 ½ to 5	+25
> 5 to 10	+35
> 10 to 15	+45
> 15 to 20	+55

** This column refers to sound path distance and not material thickness.

*Flaws evaluated with 60° or 45° search units and rejected at the acceptance levels listed in the table, but which are acceptable at the minimum acceptance level listed for a 70° transducer shall also be evaluated with a 70°, 70°, & 45° or 70° & 60° search units, as necessary to evaluate the flaw with all three angles transducers. If this detailed testing reveals that the sound beam of the 60° or 45° search unit is striking the flaw at 90°±15° the acceptance level listed for a 70° transducer shall be used as the basis for acceptance, regardless of the angle of the search unit used to evaluate the flaw.

TABLE 1700C – BUILDINGS (COMPRESSION)
Ultrasonic acceptance-rejection criteria

Flaw severity class	Weld thickness and search unit angle										
	5/16 to 3/4	>3/4 to 1 1/2	>1 1/2 to 2 1/2			>2 1/2 to 4			>4 to 8		
	70°	70°	70°	60°*	45°*	70°	60°*	45°*	70°	60°*	45°*
Class A	+5 & lower	+2 & lower	-1 & lower	+2 & lower	+4 & lower	-3 & lower	0 & lower	+2 & lower	as determined by the DCES		
Class B	+6	+3	0 +1	+3 +4	+5 +6	-2 -1	+1 +2	+3 +4	as determined by the DCES		
Class C	+7	+4	+2 +3	+5 +6	+7 +8	0 +1	+3 +4	+5 +6	as determined by the DCES		
Class D	+8 & up	+5 & up	+4 & up	+7 & up	+9 & up	+2 & up	+5 & up	+7 & up	as determined by the DCES		

NOTES:

1. Class B and C flaws shall be separated by at least 2L, L being the length of the longer flaw, except that when two or more such flaws are not separated by at least 2L, but the combined length of flaws and their separation distance is equal to or less than the maximum allowable length under the provisions of Class B or C, the flaw shall be considered a single acceptable flaw.
2. Class Band C flaws shall not begin at a distance less than 2L from weld ends carrying primary tensile stress, L being the flaw length.
3. Flaws detected at "scanning level" in the root face area of complete penetration double vee, double "J", double "U", and double bevel groove weld joints shall be evaluated using an indication rating 4 db more sensitive than that described in this table, i.e., add + 4 db to the values in this table.
4. Electroslag or electrogas welds - Flaws detected at "scanning level" which exceed 2 inches in length shall be suspected as being piping porosity and shall be further evaluated with radiography.

Class A (large flaws)

Any indication in this category shall be rejected (regardless of length).

Class B (medium flaws)

Any indication in this category having a length greater than ¾ inch shall be rejected.

Class C (small flaws)

Any indication in this category having a length greater than 2 inches in the middle half or ¾ inch length in the top or bottom quarter of weld thickness shall be rejected.

Class D (minor flaws)

Any indication in this category shall be accepted regardless of length or location in the weld.

Scanning levels

Sound path, inches**	Above zero reference, db
To 2 ½	+14
> 2 ½ to 5	+19
> 5 to 10	+29
> 10 to 15	+39
> 15 to 20	+49

** This column refers to sound path distance and not material thickness.

*Flaws evaluated with 60° or 45° search units and rejected at the acceptance levels listed in the table, but which are acceptable at the minimum acceptance level listed for a 70° transducer shall also be evaluated with a 70°, 70° & 45° or 70° & 60° search units, as necessary to evaluate the flaw with all three angles transducers. If this detailed testing reveals that the sound beam of the 60° or 45° search unit is striking the flaw at 90° ± 15° the acceptance level listed for a 70° transducer shall be used as the basis for acceptance, regardless of the angle of the search unit used to evaluate the flaw.

SECTION 18 MAGNETIC PARTICLE INSPECTION

1801. GENERAL

The New York State Steel Construction Manual adopts AASHTO/AWS D1.5: Bridge Welding Code, Section 6.7.2, 6.7.2.1, 6.7.2.3, 6.7.3, 6.7.4, Nondestructive Testing (NDT), with the following modifications:

The procedures and standards set forth in this section shall be followed whenever magnetic particle inspection is required by the Contract Documents or ordered by the DCES. All magnetic particle inspection performed by State forces, inspection agencies under contract to the State, contractors or their agents shall conform to the requirements of this Specification. Variations in testing procedures or equipment shall require approval by the DCES.

Section 6.7.4 shall be repaired as per Section 725.

1802. TESTING PROCEDURES AND EQUIPMENT

All testing shall be performed in accordance with the provisions of ASTM Designation E709, *Standard Guide for Magnetic Particle Examination*, except as modified herein. Magnetization of the part to be inspected shall be accomplished using the yoke technique.

When magnetic particle testing is used, the procedure and techniques shall be in conformance with the dry powder magnetic particle testing of welds using the yoke method.

With the yoke technique, a longitudinal magnetic field is established in the part as a result of placing the poles in contact with the part and energizing the coil of the electromagnet. Only ferromagnetic materials can be tested by this technique.

1802.1 Yoke Technique. The yoke method shall be performed in conformance with ASTM E709, and the standard of acceptance shall be in conformance with Section 724, Quality of Welds (Bridges).

- (1) Testing shall be performed using half-wave rectified DC on approved materials with the exception of HPS 70W. For HPS 70W, the provisions of the AASHTO *Guide Specification for Highway Bridge Fabrication With HPS 70W Steel, 2nd Edition*, Appendix 'A', Section 4.03, and NYS *Specification - Item 11564.40---M, HPS Grade 485W [70W]*, requiring the use of AC shall apply.

(2) Electromagnetic yokes shall have lifting forces conforming to the following requirements:

Current Type	Yoke Pole Leg Spacing (YPS), mm [in.]	
	50 [2] ≤ YPS < 100 [4]	100 [4] ≤ YPS ≤ 150 [6]
AC	45 N [10 lb.]	Not Applicable
DC	135 N [30 lb.]	225 N [50 lb.]

From ASTM E 709 TABLE 3 – Minimum Yoke Lifting Force

1802.2 Pole Positioning. The poles shall be oriented in two directions approximately 90 degrees apart at each inspection point, to detect both longitudinal and transverse discontinuities. The pole positions shall overlap as the testing progresses to insure 100% inspection of the areas to be tested. Discontinuities are best detected when their major axis is normal to the magnetic lines of force. The yoke technique is most sensitive to discontinuities whose major axis is normal to a line drawn between the two poles.

The New York State Steel Construction Manual adopts AASHTO/AWS D1.5: Bridge Welding Code, Section 6.7.6.3, replacing Surface Condition.

1803. WITNESSING OF MAGNETIC PARTICLE TESTS

All magnetic particle inspection that is not performed by State forces or an inspection agency under contract to the State shall be witnessed by a representative of the State.

1804. PREPARATION AND DISPOSITION OF REPORTS

The test technician shall prepare a test report for each erection piece subject to inspection. All indications of discontinuities shall be recorded in the test report. The report shall contain the following information to identify the extent of the weld or base metal inspected:

- (a) Part Identification; including contract number, project identification number (PIN), county, fabricator’s shop order number and the erection mark
- (b) Examination procedure number (if applicable)
- (c) Date of examination
- (d) Technician’s name, certification level, and signature
- (e) Name and signature of the State representative who witnessed the examination, if required by Section 1803
- (f) Examination results
- (g) Equipment make and model
- (h) Yoke spacing and type of current used
- (i) Dry Powder particles (manufacturer’s name) and color

A complete set of test reports shall be delivered to the DCES upon completion of the work.

1805. STANDARDS OF ACCEPTANCE

Welds subject to magnetic particle inspection shall have no cracks. Porosity and fusion type defects shall be evaluated in accordance with the provisions of Sections 724 or 725 as applicable.

Notes:

SECTION 19

DYE PENETRANT INSPECTION

1901. GENERAL

The procedures and standards set forth in this Section shall be used whenever liquid (dye) penetrant inspection is required by the Contract Documents or ordered by the Engineer under the provisions of these Specifications. This inspection method is limited to the detection of discontinuities that are open to the Surface. Penetrant tests shall only be performed when the steel is between the temperature of 40° F to 125°F.

1902. TESTING PROCEDURES

All testing shall be performed in accordance with the provisions of ASTM Designation E165, *Standard Test Method for Liquid Penetrant Examination, Type II, Method C, Visible Solvent Removable Penetrant*; And ASTM Designation E1220, *Standard Test Method for Visible Penetrant Examination Using Solvent – Removable Process*.

The surface being inspected shall be cleaned in accordance with ASTM Designation E165. Surface irregularities that interfere with the interpretation of test results shall be removed by grinding. All welds shall be smoothed by grinding prior to testing.

1903. WITNESSING OF LIQUID (DYE) PENETRANT TESTS

All liquid (dye) penetrant inspection that is not performed by State employees or an inspection agency under contract to the State shall be witnessed by a representative of the State.

1904. PREPARATION AND DISPOSITION OF REPORTS

A test report shall be prepared for each erection piece subject to inspection. The report shall be prepared by the technician performing the test. The report shall contain sufficient information to identify the extent of the weld or base metal inspected, the name of the technician (signature), and the name of the State representative witnessing the work, if required by Section 1903. All indications of discontinuities shall be recorded in the test report. The contract number, project identification number (PIN), county, and date of test shall be listed on each report together with the fabricator's shop order number and the erection mark on the piece.

A complete set of test reports shall be delivered to the DCES upon completion of the work.

1905. STANDARDS OF ACCEPTANCE

Welds subject to liquid (dye) penetrant inspection shall have no cracks. Porosity and fusion-type defects shall be evaluated in accordance with the provisions of Sections 724 or 725 as applicable.

Notes:

APPENDIX A REPAIR OF UNACCEPTABLE FASTENER HOLES

A1. GENERAL

When mislocated or unacceptable holes are made in base metal, the DCES shall be notified and shall determine if repair will be permitted or replacement of the piece is required.

When the DCES determines that repair of the piece is permitted, the Contractor (Fabricator) shall submit a written repair proposal with drawings in accordance with the provisions of Section 205. The DCES shall review and approve the repair procedure before any work is done.

A2. PREPARATION OF HOLES FOR REPAIR

When a welded repair is approved by the DCES, the holes shall be prepared for welding in the following manner:

- 1) Insert a tightly fitted steel "slug" into the hole, to one-half the hole depth. The slug shall be of the same material as the base metal.
- 2) Beginning on the unfilled side of the hole, prepare an elongated, boat-shaped cavity down to and slightly into the slug. When repair welding is to be performed in the flat position, the sides of the cavity should slope back 10° minimum and the ends should slope back 45° minimum. The cavity may be made by grinding or air carbon arc gouging followed by grinding.
- 3) Completely fill the cavity with weld metal using an approved weld process and employing a stringer bead welding technique. Weaving or plug welding will not be permitted.
- 4) Backgouge to sound weld metal and prepare a similar cavity on the other side by the same method. Backgouging shall completely remove all remnants of the slug and extend into sound weld and base metal.
- 5) Fill this cavity with weld metal using the procedure described in 3) .

When two or more adjacent holes are to be repair welded, the repair cavity shall combine holes or repair holes singly as determined by the DCES.

When a piece with unacceptable holes is fixed in the vertical position, the repair shall be made so that the long axis of the cavity is horizontal and the top of the cavity shall slope upwards at 45° minimum.

A3. WELDING

Repair welding shall be done by processes and procedures which are approved by the DCES. Only the stringer bead technique will be approved. All welding shall be performed by welders or welding operators qualified in accordance with Section 8, Qualification. All welding shall utilize a minimum preheat and interpass temperature of 250°F. The DCES may specify higher preheat and interpass temperature and post heat as necessary.

Repair welding of unacceptable holes in Fracture Critical Members shall be considered Category III repairs and all provisions of the Fracture Control Plan shall apply.

A4. NONDESTRUCTIVE TESTING

All repair welds shall be ground flush and smooth as described in Section 723 prior to nondestructive testing.

Holes which are repair welded in main stress carrying material shall be radiographed and evaluated in accordance with Section 16 and Figure 1605a of this Manual.

Holes which are repair welded in secondary members shall be either radiographed or ultrasonic tested by a State certified technician. The choice of testing method and weld quality standard shall be as ordered by the DCES.

Repair welds in fracture critical members shall be radiographed and ultrasonic tested as required for FCM's.

If a new hole is to be made in close proximity to a repaired hole, the nondestructive testing shall be performed and the repair approved before the new hole is drilled.

APPENDIX B SAMPLE REPAIR DRAWING

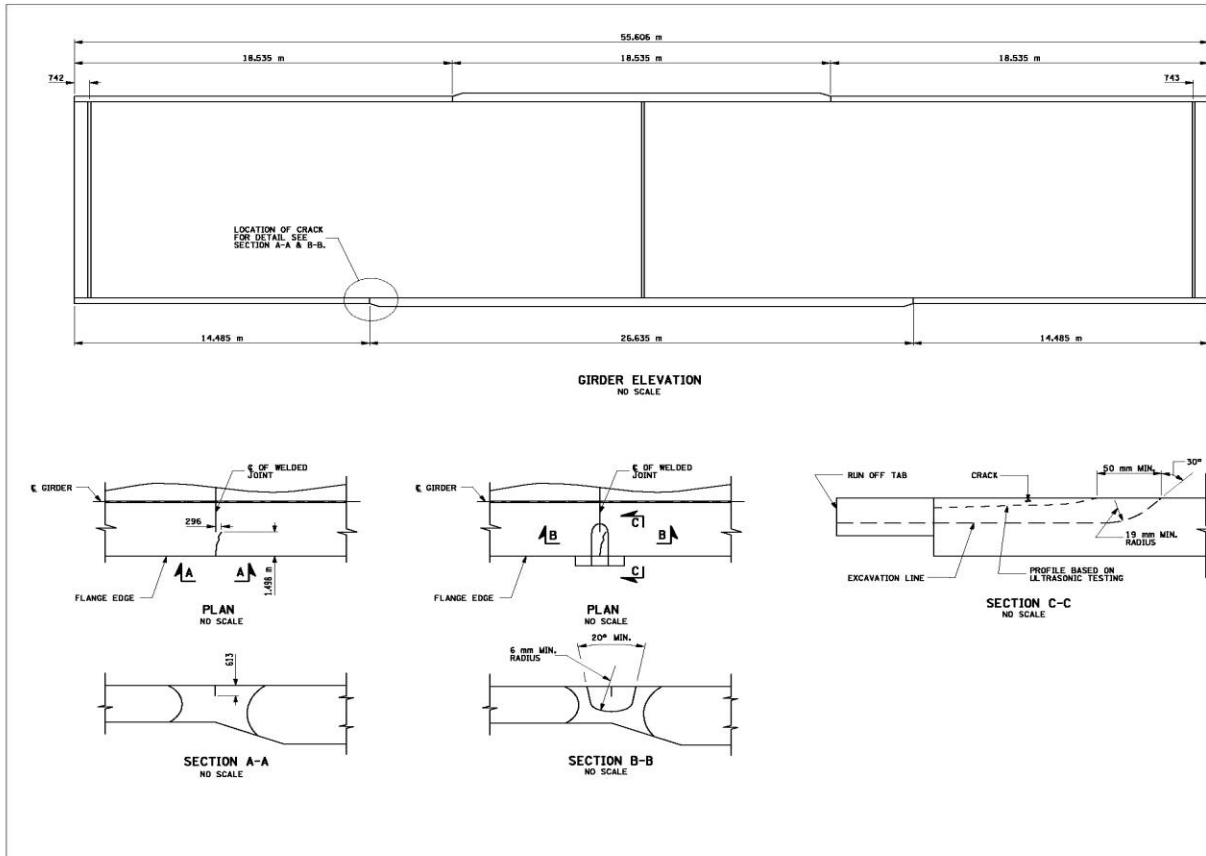

**APPENDIX B
SAMPLE REPAIR DRAWING**

NOTE:
THE CRACK WAS DISCOVERED DURING RADIOGRAPHIC INSPECTION. THE EXTENT AND SHAPE OF THE CRACK AS SHOWN IN DETAIL A WAS DETERMINED BY MAGNETIC PARTICLE AND ULTRASONIC TESTING IN ACCORDANCE WITH THE PROVISIONS OF THE NEW YORK STATE STEEL CONSTRUCTION MANUAL (SCM).

CATEGORY III REPAIR PROCEDURE

- 1) PREHEAT THE WORK AREA OF THE FLANGE PLATE TO 150°F MINIMUM. AFTER PREHEATING, AIR CARBON ARC GROUND AS SHOWN IN DETAIL B TO REMOVE THE CRACK.
- 2) GRIND THE SURFACE OF THE EXCAVATION TO REMOVE CARBON PICK-UP AND IRREGULARITIES.
- 3) PERFORM MAGNETIC PARTICLE INSPECTION OF THE EXCAVATION TO INSURE COMPLETE REMOVAL OF THE CRACK.
- 4) PREHEAT THE FLANGE REPAIR AREA TO 350°F MINIMUM AND MAINTAIN PREHEAT, INTERPASS TEMPERATURE, MAINTENANCE, AND POSTHEAT SHALL BE CONTIGUOUS OPERATIONS.
- 5) WELD THE EXCAVATION USING THE SUBMERGED ARC PROCESS IN ACCORDANCE WITH THE PROVISIONS OF THE APPROVED WELDING PROCEDURE SPECIFICATION.
- 6) REMOVE THE RUN-OFF TAB AND GRIND THE REPAIRED AREA FLUSH AND SMOOTH.
- 7) INCREASE THE HEATING TEMPERATURE TO BETWEEN 400°F AND 500°F. MAINTAIN THE POSTHEAT TEMPERATURE FOR 1 1/2 HOURS MINIMUM AFTER THIS TIME PERIOD, REDUCE AND THEN REMOVE THE HEAT SOURCE AND COVER THE WELDMENT SO THAT THE REPAIR WELD WILL COOL SLOWLY TO AMBIENT TEMPERATURE.
- 8) RADIOGRAPH THE REPAIRED AREA.
- 9) PERFORM ULTRASONIC INSPECTION AFTER THE REPAIRED AREA HAS COOLED TO AMBIENT TEMPERATURE FOR AT LEAST 24 HOURS.
- 10) ALL NOT SHALL BE DONE IN ACCORDANCE WITH THE PROVISIONS OF THE SCM.

DEFECT HAS BEEN EXAMINED PRIOR TO REPAIR AND APPEARS TO TO BE AS DESCRIBED.

QA INSPECTOR _____ DATE _____

REPAIR HAS BEEN COMPLETED, TESTED AND IS ACCEPTABLE.

QA INSPECTOR _____ DATE _____

N.Y.S. CONTRACT NO.	_____
SUOP ORDER NO.	_____
REF. REFERENCE NO.	_____
SECTION PIECE MARK	_____
BASE METAL SPEC.	_____
DEFECT DESCRIPTION	_____

Notes:

APPENDIX C
GUIDE FOR INDEPENDENT QUALITY ASSURANCE INSPECTORS

Table of Contents

C1.	Specifications and Documents	C2
C1.1.	Available Documentation	C2
C1.2.	Familiarization with Requirements	C2
C1.3.	Use of Shop Drawings	C2
C2.	Inspection Equipment	C3
C3.	Inspector Qualifications	C3
C3.1.	Fabrication Inspection Qualifications	C3
C3.2.	Minimum Inspection Experience	C4
C3.3.	Coatings Inspection Qualifications	C4
C3.4.	Training.....	C4
C4.	Records and Reporting	C4
C5.	General Instructions	C5
C5.1.	Responsibilities of the QAI.....	C5
C5.2.	Role of the QAI.....	C5
C5.3.	Interaction with the Fabricator Quality Control Inspector.....	C5
C5.4.	Interaction with the Engineer.....	C6
C5.5.	Interpretation of the Contract.....	C6
C5.6.	Fabrication Observation.....	C6
C5.7.	Nonconforming Materials and Workmanship.....	C6
C6.	Inspection Procedures	C7
C6.1.	Mill Test Reports	C7
C6.2.	Inspection of Raw Materials	C7
C6.3.	Material Cutting Inspection	C7
C6.4.	Fit-up and Welding Inspection.....	C8
C6.5.	Nondestructive Testing	C9
C6.6.	General Visual Inspection.....	C9
C6.7.	Dimensional Inspection	C10
C6.8.	Bolting Inspection.....	C10
C6.9.	Coating Inspection	C11
C6.10.	Fracture Critical Members	C11
C7.	Material Storage.....	C12
C8.	Loading and Shipping	C12
C9.	Final Acceptance.....	C12

C1. SPECIFICATIONS AND DOCUMENTS

C1.1 Quality Assurance Inspectors (QAIs) shall obtain, or have available the following documentation at the fabrication shop:

- applicable current standard specifications, supplements, special provisions, special specifications, and addenda
- approved shop drawings with current revisions
- fabricator's Quality Control Plan (QCP), which is to include the company's Non-Destructive Evaluation (NDE) written practice
- prefabrication meeting minutes, if any
- NYS Steel Construction Manual and applicable AASHTO/AWS D1.5, Bridge Welding Code
- applicable American Welding Society (AWS) D1.1, *Structural Welding Code*
- applicable provisions of the AREMA Manual for Railway Engineering, if required for the project
- AWS A2.4, *Symbols for Welding and Nondestructive Testing*
- AWS A3.0, *Standard Welding Terms and Definitions*
- applicable ASTM or AASHTO specifications
- applicable coating test methods
- applicable SSPC Specifications
- metrication conversion tables, if required
- Mill Test Reports (MTRs) for material used in fabrication
- list of qualified welders, welding operators, and tack welders
- approved welding procedure specifications (WPSs)
- approved welding procedure qualification records (PQRs)
- applicable pre-approved non-fracture critical material (FCM) repair procedures
- applicable approved repair procedures
- copy of written practice for NDE
- qualification documents for all certified welding inspectors (CWI) and NDE quality control (QC) personnel
- NDE reports for all work on this project that has been inspected and accepted by NDE
- Project record log sheets

C1.2 Familiarization with Requirements

The QAI shall become familiar with applicable portions of the Contract documents covering the work to be inspected. The QAI shall study the plans and specifications as well as the SCM before fabrication commences to provide ample opportunity to coordinate with the Engineer.

C1.3 Use of Shop Drawings

The QAI should become familiar with the shop drawings. The QAI shall coordinate with the Owner regarding any discrepancies between the plans and specifications and the shop drawings. Fabrication should proceed only with approved shop drawings. However, if the Fabricator elects to proceed prior to receipt of approved shop drawings (performing work at their own risk), notify the Owner and, if directed proceed with QA functions using non-approved shop drawings. Later, verify conformance of fabrication with the approved drawings. The shop must submit revisions to the shop drawings to the Owner for approval to reflect changes in details and provide a permanent record of the as-built condition. The QAI should ensure that fabrication is in conformance with the latest revisions. The inspector shall not place its acceptance stamp on the material nor sign a Form B&GC 4b prior to receipt of approved drawing revisions in the shop.

C2. INSPECTION EQUIPMENT

The QAI shall have/or have available the following equipment at the fabrication shop. Some equipment may not be applicable depending on the nature of fabrication:

Items marked with an asterisk may be supplied by the contractor.

- tape measure, 25 ft. (7 m), 1/32 in. or 1 mm increments
- magnifying glass
- metal tape measure, 100 ft (30 m), 1/8 in. or 0.01 ft. (5 mm) increments
- steel wire *
- pocket metal ruler(s), 1/32 in. or 1 mm increments
- straight edge *
- flashlight and spare batteries
- camera; QAI to photograph only raw and fabricated materials produced for the owner
- calipers *
- feeler gauges
- pit depth gauge*
- fillet weld gauges
- undercut gauge
- skewed fillet weld gauge
- bevel gauge
- micrometer
- mirror for examining restricted access areas (such as snipes)
- NDE tools, if applicable
- portable Rockwell C hardness tester
- surface roughness gauges for machine and flame cutting
(Ref. ANSI B41 or AWS C4.1-G)
- welding shield *
- temperature indicating crayons for 600, 1000, 1100 & 1250°F or surface pyrometer
- sling psychrometer
- thermometers for determining air, paint and metal surface temperatures
- blast profile comparator or replica tape for direct measurements and a permanent record
- wet film thickness gauge
- dry film thickness gauge
- tools for checking surface anomalies, coating adhesion, etc.
- surface profile comparator for media (sand, shot or grit) used and/or deformable replica
- tape and micrometer to check profile depth before coating
- 10X Lens
- approved acceptance stamp

C3. INSPECTOR QUALIFICATIONS

QAIs shall have the following minimum required knowledge, abilities, and experience:

C3.1 Fabrication Inspection Qualifications

A QAI performing welding inspection must be a Certified Welding Inspector (CWI) or equivalent, in accordance with the Bridge Welding Code. QAIs who are Certified Associate Welding Inspectors (CAWI) may work under the direct supervision of a CWI. QAIs who interpret and perform NDE must be certified in accordance with the applicable ASNT SNT-TC-1A requirements for each NDE method being used in accordance with the Bridge Welding Code.

C3.2 Minimum Inspection Experience.

A QAI performing welding inspection should have the following minimum inspection experience:

Project Type	Minimum Recommended Years of Experience*
Rolled beam bridges	1 year
Welded plate girders (I sections, box sections, etc.)	2 years
Complex structures, such as trusses, arches, cable-stayed bridges, and moveable bridges	3 years
Fracture critical members (FCM)	3 years

*Experience in rolled beam bridge inspection will not be counted towards the experience needed for plate girders, complex structures, or fracture-critical members.

Inspectors who have less experience than that specified above should work under the guidance of an inspector having those qualifications. QAIs must be proficient with the typical fabrication inspection procedures described in this document.

C3.3 Coatings Inspection Qualifications.

A QAI performing coatings inspection must be qualified to inspect coatings and coatings applications.

C3.4 Training

Documented training in materials preparation, coatings application, and inspection is suggested for the QC and QA coatings inspectors. Recommended training includes one or more of the following:

- American Institute of Steel Construction (AISC) – Application and Inspection of Sophisticated Coatings
- National Association of Corrosion Engineers (NACE) – International Coating Inspector training and Certification Program Session I: Coating Inspection Training
- Society for Protective Coatings (SSPC) – C-1 Fundamentals of Protective Coatings for Industrial Structures
- Other training programs that are considered acceptable by the DCES.

C4. RECORDS AND REPORTING

The QAI shall maintain neat and orderly records for each project. Documentation of the status of fabrication and acceptability of members shall be performed on the forms included in Appendix F.

In addition to completion of the necessary forms, the QAI shall maintain a narrative report for each project, as directed by the DCES. The narrative report should either be legibly handwritten in a permanently bound book, or be maintained in an electronic log with automatic date and time recording. Record the Fabricator's activity on the work inspected, including both positive and negative comments, information provided to the Fabricator and any agreements made. Make entries as soon as possible after the events or conversations.

Obtain copies of Fabricator generated records such as NDE reports, inspection reports, etc. for the project files and submission to the DCES as directed.

Furnish a written report on a weekly basis to the DCES as directed. Include those forms and documents required by the DCES. Number the reports consecutively until completion of the work, with the last report noted "final."

Make notes, letters, faxes, reports, and memoranda clear and brief, and keep them on file. Sign on-site correspondence as its originator.

The QAI should maintain verbal communication with the DCES or the DCES' representative as directed. The QAI shall also maintain good relations with the Fabricator's Quality Control Inspector (QCI). Ensure that both the DCES and QCI are timely apprised of the QAI's findings including nonconformances. Written documentation is not a substitute for appropriate dialogue with the Fabricator, but should provide a record of important discussions.

C5. GENERAL INSTRUCTIONS

C5.1 Responsibilities of the QAI

Verify that production quality and fabrication processes satisfy contract requirements, including the QCP. Verify that the fabricator has QCI performing inspection functions during all fabrication operations. Perform QA inspections in accordance with this manual and other instructions by the Engineer. Determine extent and frequency of inspection based on the Engineer's direction.

Check mill test reports to verify that the mechanical properties, chemical analysis, and BUY AMERICA provisions when required, conform to the requirements of the Contract Documents. Verify the heat identity of random plates and shapes. Verify the heat identity of all fracture critical material. Visually inspect surfaces and machined ends.

Do not direct the Fabricator's personnel. Do not provide suggestions on how to fabricate material. However, the QAI should advise the Fabricator if any operation would, in their opinion, result in noncompliance with the Contract. Direct all official communications to the Fabricator's quality control. Do not convey directives or personal judgments about overall shop quality or concerns about employee competence to production personnel.

Do not divulge a fabricator's proprietary information to another fabricator. Do not publish, copy or distribute any proprietary information, documents, or forms received from the Fabricator for any purpose other than the contractual needs of the Owner.

C5.2 Role of the QAI

Perform verification tests, measurements, inspection, or observations to assure that fabricated items conform to the Contract requirements. Although the QAI does not perform QC work, some QA activities may duplicate a portion of QC activity for verification.

If there are questions about a requirement or level of quality, contact the Engineer and, if directed, alert the Fabricator.

Conduct consistent inspections based on the Contract requirements while providing guidance to the Fabricator concerning interpretation of the plan details and specification mandates. Obtain assistance from the Engineer as needed.

Be familiar with the QCP to better understand the QC operations of the shop. Verify that the shop is conducting operations in accordance with their QCP.

C5.3 Interaction with the Fabricator Quality Control Inspector

Verify the effectiveness of the QCI's evaluation of the work.

Perform verification inspection after the QCI has completed inspection and testing in accordance with the QCP. However, serious problems noted at any time or stage of fabrication must be immediately pointed out to the QCI. Notify the Engineer if there are any unresolved problems.

Though QC inspection may include all aspects of fabrication, the QAI must not supersede QC, which is the responsibility of the Fabricator. If QC is not accomplishing its role, the Engineer and Fabricator must determine the necessary corrections.

C5.4 Interaction with the Engineer

If the Fabricator's inquiries involve design questions, material substitutions, alternate fabrication methods, or items that are beyond the authority of the QAI, refer them to the DCES.

C5.5 Interpretation of the Contract

Review Contract requirements. If conflicts arise regarding their interpretation or adequacy, seek guidance from the Engineer. Inform the QCI of the results of this discussion.

C5.6 Fabrication Observation

Establish a proactive pattern of regular and frequent observations during the progress of work to verify satisfactory workmanship without delaying production or missing critical operations.

Coordinate verifications with the QCI and accomplish them with minimal additional material handling by the Fabricator and with as little interference with the work in process as possible.

Though there are not designated points during fabrication when the suitability of materials must be checked, problems should be discovered and addressed as early as possible.

C5.7 Nonconforming Materials and Workmanship

A nonconformance is defined as a fabrication error or alteration in the work that does not meet project specifications. Some minor nonconformances can be remedied as provided for in this manual and project specifications. A typical example of this would include cosmetic weld repairs. Other nonconformances may be more serious and cannot be remedied through simple repair as allowed in the SCM. These types of nonconformances render the affected component unacceptable until such time as the issue is referred to the DCES for disposition. Typical examples of these nonconformances include, but are not limited to, mislocated holes, incorrect material, and final dimensions not in accordance with approved drawings, unauthorized welds, welding without approved welding procedures, and overheating of members. When in doubt regarding the proper disposition method, the QAI should obtain clarification from the DCES as necessary.

Bring all nonconformance issues to the attention of the Fabricator immediately upon discovery. However, do not direct corrective action. If the Fabricator fails to take corrective action, or continues to operate in an unacceptable manner, immediately notify the DCES. Verbal notification of nonconformance issues to the fabricator is sometimes sufficient; however serious specification noncompliance issues should always be conveyed in writing to the fabricator and the DCES.

For significant problems, the Fabricator must submit a written proposal concerning the issue, providing documentation of the situation and proposed actions to address the issue. The Fabricator may write directly to the DCES, Contractor, or both, as directed, and in all cases send a copy to the QAI.

When the DCES' approval is required for a repair, the inspector shall review and confirm the Fabricator's proposed methods of repair and description of the existing material conditions. Seek guidance from the DCES for clarification when necessary. Follow up to verify that all required corrections and applicable NDE have been accomplished. All nonconformances shall be properly resolved before the members can be considered for final acceptance.

C6. INSPECTION PROCEDURES

C6.1 Mill Test Reports

C6.1.1 Verify use of proper materials by reviewing a copy of the MTRs when the material arrives and by monitoring heat numbers during fabrication until the material is joined into a piece-marked item.

C6.1.2 Obtain MTRs from the Fabricator in accordance with Section 508.

C6.1.3 Verify the following information on MTRs:

- Product description (specifications, grade, H or P testing frequency)
- Chemistry
- Physical test results, including Charpy V-Notch when applicable
- Applicable “Buy America” certification requirements
- Heat number
- Certification signature (Quality Control Department and Notary, when required)

C6.1.4 Do not accept material if the Fabricator cannot furnish appropriate certifications to establish compliance with the required material properties and “Buy America” requirements.

C6.1.5 Maintain a record of heat number identification for main members.

C6.1.6 Accept structural steel based on MTRs.

C6.1.7 If the Department requires additional independent physical and/or chemical tests of the material’s properties, then these tests must be performed as soon as practical, and prior to fabrication. If the independent tests indicate noncompliance, do not allow use of the material unless an agreement is reached between the Department and Fabricator as to its acceptability. Bring such noncompliance to the attention of the QCI for evaluation and disposition.

C6.1.8 Verify compliance of MTRs with the requirements of the relevant ASTM or AASHTO specification.

C6.2 Inspection of Raw Materials

C6.2.1 Verify that the requirements of ASTM A 6 (AASHTO M 160) or ASTM A 20 as applicable, which cover the common requirements for hot-rolled plates, shapes, sheet piling and bars, are applied, as applicable, for material acceptance inspection and repairing certain surface defects.

C6.2.2 Check materials for surface defects and discontinuities, both initially and as material is being worked. Check rolled sections and steel castings for dimensions, straightness, twist, fins, scabs, and rolling defects, prior to fabrication.

C6.2.3 Grade of material shall be in accordance with the shop drawing / project requirements. No unauthorized substitutions of material (size or grade) are allowed without the DCES approval.

C6.3 Material Cutting Inspection

C6.3.1 Check that methods employed for material cutting are allowed by the contract documents specifications. Monitor steel plate during cutting for internal defects or other problems. Check that cutting methods do not produce unacceptable gouges or surface roughness. Check that internal defects or gouges are evaluated and repaired in accordance with the requirements of this manual. Verify that heat numbers are being transferred to cut members.

C6.3.2 Measure hardness on cut edges when required.

C6.4 Fit-up and Welding Inspection

C6.4.1 Review the consumable manufacturer's certificate of conformance maintained by the Fabricator for all consumables used and obtain copies for the project file.

C6.4.2 Monitor these criteria before welding begins:

- Approved shop drawings clearly indicate the details of welded joints by welding symbols or sketches. Missing or inappropriate weld details are unacceptable and shall be referred to the Fabricator and DCES for disposition. Approved drawings must be corrected and approved prior to final acceptance.
- Appropriate equipment in acceptable condition and periodically calibrated per QCP.
- Proper functioning of drying and baking ovens
- All welders, welding operators, and tack welders are qualified in accordance with the contract documents and this manual.
- Appropriate welding procedure specifications (WPS) for all detailed joints have been submitted and approved by the DCES.

C6.4.3 Monitor these consumable-handling criteria (randomly audit):

- Storage, condition, and exposure times of welding consumables
- Re-drying and recycling limits

C6.4.4 Monitor these criteria during welding operations (randomly audit):

- Joint details, including root face and opening, bevel angle, and alignment of parts are within appropriate welding code and WPS tolerances
- Proper application of extension tabs (run-on and run-off)
- Cleanliness of surfaces to be welded
- Proper condition and storage of welding consumables
- Size, quality and location of tack welds.
- The following of approved welding procedure specifications (WPSs) including amperage, voltage, speed of travel, electrode extension, shielding gas flow rate, and preheat, interpass, and/or post-heat temperatures within applicable welding code and WPS tolerances.
- Workmanship of individual welders
- Use of proper repair procedures for fabrication errors, including, when required, the DCES' approval
- Weld starts and stops, securing and removing run-on and run-off tabs, stopping short of snipes or plate edges, and ending without craters
- For stud welding, ensure test studs are being performed and materials are acceptable.
- Check that pieces, when assembled, will be stressed parallel to rolling direction

C6.4.5 Monitor these final weld quality criteria:

- Size, profile, and contour of fillet and groove welds
- Defects in welds or parent metal only as permitted by contract documents and code/specifications
- Accurate interpretation by QCIs for the acceptance or rejection of welds
- Cleaning and back-gouging of welds, including thorough removal of unsound metal and gouging contamination (copper, carbon). Check proper profile of back-gouged weld for compliance.
- Overgrinding of weld or adjacent base metal areas so as to reduce material/weld throat.
- Stud welds exhibit full 360 degree flash or arc welded studs are visually acceptable
- Verify that post heat, when required, is maintained at the required temperature for the specified minimum time. Determine that post heat is initiated immediately upon completion of welding.

- Observe removal of run-off plates and weld backing to insure that destructive procedures are not employed.
- Determine that grinding of surfaces and edges conforms to specification requirements and does not reduce weld and base metal thicknesses below acceptable limits.
- Observe (spot check) preparation for radiography and radiographic technique. Review radiographs and reports.
- Inspect preparation for repair welding, welding, and post heat when required.

C6.5 Nondestructive Testing

C6.5.1 Review and approve the personnel qualification documentation of those performing NDE for the Fabricator. Assure that all NDE is being scheduled by QCI so that QAI witnessing of the NDE operation is possible.

C6.5.2 Periodically witness NDE, review the test results, and verify that reports are complete and legible and completed in a timely manner.

C6.5.3 For radiographic testing (RT), conduct the following activities:

- Interpret test results in accordance with the contract documents.
- Verify that final edges may be properly interpreted. (If the plate will be cut after RT, the final edge may be within the plate on the RT film.)
- Verify proper application of edge blocks if necessary (plate edge is final edge in structure).
- Verify that each radiograph represents a unique section or piece by comparing punch marks or other approved methods of marking the work and corresponding marks on the film
- Verify that the entire specified area is tested.

C6.5.4 Periodically observe or conduct, if necessary, ultrasonic testing (UT) to verify the Fabricator's NDE results. The QAI will determine intervals for observation of verification testing unless otherwise directed by the DCES.

- Verify the calibration of equipment, including horizontal and vertical linearity checks.

C6.5.5 For magnetic particle testing (MT), conduct the following activities:

- Periodically observe the application and interpret the results of MT performed on primary members to verify that they satisfy requirements of this manual.
- On ancillary, secondary or miscellaneous items, periodically observe and interpret MT when required by the contract documents.
- Observe MT when needed to verify visual findings.
- Observe and interpret MT applied to evaluate removal of defects and welded shop repairs for base metal and deficient welds.
- Assure Section 18 compliance including assurance that proper lighting levels are maintained during testing.

C6.5.6 For liquid penetrant testing (PT), periodically observe technique and interpret results.

C6.6 General Visual Inspection

During fabrication the QAI should monitor and spot-check that the work performed by the fabricator meets the contract requirements, including, as a minimum, the following:

- Straightness
- No unauthorized corrections made by welding or manual thermal cutting
- Size and quality of punches and dies
- Proper setup and securing of drilling or reaming templates
- Bolt hole location, edge distance, and diameter
- Cylindrical and perpendicular bolt holes

- Absence of burrs, tears, and chips in bolt holes
- Thickness of plates, clearances, fitup accuracy, alignment of holes, and proper size of sections at field connections
- Shop assembly of girders or other parts required for reaming or drilling of field splice holes: positioning, securing, match marking members and splice plates, splice plate orientation (flange splice plates' rolling direction parallel to flanges),fills in assembly, and all plies in contact when assembled.
- Flatness of flanges at bearing area
- Bearing plates and bearing assemblies, including rockers and shoes for structural steel and expansion joints
- Proper surface finish and protection of machined surfaces
- Contact condition of milled bearing surfaces
- Camber blocking during girder assembly, prior to drilling and QAI acceptance for disassembly
- Records of final sweep or camber
- Inspection and installation of fasteners in the shop
- Location of stiffeners and connection plates
- Match-marking of assembled members
- Preparation of match-mark diagrams
- Control and use of heat and/or pressure to obtain or correct sweep and camber in accordance with shop's QCP, and avoidance of buckles, twists, kinks or other defects
- Legibility and position of erection and shipping marks
- No unacceptable twists, bends, kinks, or sweep in finished members
- Proper number of pieces
- Small parts properly packaged or otherwise secured against loss or damage in transit
- Loose pieces fastened in place for shipment
- Check cleaning of weathering steel and covering to prevent contamination of painted surfaces
- No cutting apart of welded members without the DCES approval

C6.7 Dimensional Inspection

C6.7.1 Observe laydowns and shop assembly

C6.7.2 Verify the Fabricator's geometry control methods and measurements. For full or partial shop assemblies, receive the QCI's signed reports of measurements for the Department's records. If requested by the Department, photographs should also be included in the QAI's report.

C6.8 Bolting Inspection

C6.8.1 Verify the acceptability of fastener components by reviewing MTRs and test reports (including rotational capacity test reports)

C6.8.2 If fasteners to be tested by the Department are sampled at the Fabricator's facility, witness and document sampling of components for fastener assemblies in accordance with the Department's practice.

C6.8.3 Verify that all fasteners are properly stored and segregated.

C6.8.4 When fasteners are installed in the shop, ensure that installation and verification testing procedures are properly followed.

C6.8.5 Witness the rotational capacity and verification testing for shop-installed high-strength fasteners.

C6.8.6 Assure current calibration and functionality of torque wrenches and bolt tension-indicating devices.

C6.9 Coating Inspection

C6.9.1 When shop sampling is performed:

- Coordinate coating sampling in the shop with the Fabricator.
- Conduct sampling as early as possible
- Witness sampling, including mixing or stirring if required for uniformity.
- Ensure that the required samples are delivered to the Owner in suitable containers.

C6.9.2 If sampling is not required, check the owner-maintained list of pre-test, pre-approved coatings to ensure that the actual batches or lots of the paint to be used are acceptable.

C6.9.3 If the paint manufacturer sends coating samples directly to the Department for testing and the batches are approved prior to shipment to the Fabricator or jobsite, verify that the batch numbers received correspond to the approved list, and, if applicable, that approval stamps are present.

C6.9.4 Prior to coating application, verify the following:

- Coating containers are properly marked with a batch number.
- Batches have been properly strained and mixed (note when pot life initiates).

C6.9.5 When sampling is required, do not accept coated girders until the Department's lab accepts the coating.

C6.9.6 For coating application inspection, verify the following:

- The shop is checking and documenting environmental conditions and coating is being applied and cured within acceptable conditions.
- Proper cleaning and surface preparation of base metal prior to application of coating in accordance with manufacturer and/or contract requirements.
- Adequate curing of each coat as demonstrated by the prescribed test and, when multi-coat systems are used, prior to the application of subsequent coats
- Thickness of coating, wet or dry, as specified for each system and type
- Sufficient drying of coating prior to loading for shipment
- Absence of dry spray, runs, sags and other defects
- Proper coating of inaccessible and limited access areas
- Proper treatment of faying surfaces

C6.10 Fracture Critical Members

C6.10.1 When fabrication is to occur on members designated as Fracture Critical Members (FCMs), the QAI shall become familiar with the requirements of the NYSSCM Section 9.

C6.10.2 Check that the base metal complies with the additional requirements for FCMs including fine-grain practice, prohibition of mill repairs, and toughness requirements.

C6.10.3 Check that the Fabricator has complied with the more stringent purchasing, storing, and handling requirements for consumables as required by the Fracture Control Plan.

C6.10.4 Check that the fabricator complies with the additional fabrication requirements of the Fracture Control Plan including preheating requirements, tack welding limitations, and straightening/cambering/ curving requirements.

C6.10.5 Confirm that repair welding conforms to the Fracture Control Plan. “Noncritical Repairs” may be preapproved by the DCES. “Critical Repairs” shall be approved by the DCES prior to beginning the repair and shall be documented giving details of the type of discontinuity, location, and extent of repair. Verify that all discontinuities to be repaired are covered by the repair procedure. All repair welding shall be monitored and inspected by the QCI and QAI.

C6.10.6 Confirm that the repair is properly made in accordance with the approved repair procedure including additional requirements such as proper preheat, postheat, and nondestructive testing.

C7. MATERIAL STORAGE

The project schedule may require that completed members be stored at the fabrication shop or other location for a period of time before shipment to the jobsite. Check that the completed members are stored in a manner that will not cause distortion or damage. Check that lifting devices do not damage the material or the coating. The fabricator is responsible to repair any storage damage prior to shipment to the project.

C8. LOADING AND SHIPPING

When all work is complete, conduct a final visual examination of the work.

The QCI will provide copies of reports covering the materials to be shipped. Verify that all data are correct.

Randomly observe handling and loading of the work to verify that the methods and supports used will prevent significant damage during shipping. Check that damage to coatings during the storage and loading process are properly repaired as appropriate.

C9. FINAL ACCEPTANCE

When fabrication is complete and the inspection results demonstrate that all contract documents have been satisfied, the materials are conditionally accepted. Confirm that all nonconformances have been properly resolved.

Affix the approval stamp or shipping tag on the fabricated piece (or a group of parts bundled or contained together), if required, during preparation of a member/component for shipping, indicating that a representative of the Owner has inspected and accepted the work. Presence of this stamp does not relieve the Contractor of responsibility for proper loading, shipping, final fit, and acceptable final condition of the member or component.

If the fabricator elects to ship material that does not meet the contract documents or has unresolved nonconformances, immediately contact the DCES to notify. Do not affix an approval stamp or tag to the fabricated component(s) and do not issue a B & GC 4b form.

If the material is being shipped to a secondary processor such as a galvanizer or coater, then final acceptance/stamping may occur at that location. Coordinate with the DCES to confirm the method for inspection at the secondary location.

Send signed copy of B & GC 4b to Regional Construction Engineer and one copy to the jobsite.

APPENDIX D TERMS AND DEFINITIONS

A

acceptable weld: A weld that meets all the requirements and the acceptance criteria prescribed in the welding specifications.

actual throat: The shortest distance between the weld root and the face of a fillet weld.

air carbon arc gouging: A process for metal removal where the metal is melted by an electric arc and blown clear of the removal area by compressed air. Inert gas may be approved by the DCES for special applications where compressed air is not readily available.

all weld metal tension specimen: A test specimen with the reduced section composed wholly of weld metal.

amplitude (UT): The vertical height of the trace deflection on the display of the ultrasonic flaw detector.

amplitude length rejection level (UT): The maximum length of discontinuity permitted by various indication ratings associated with weld size, as indicated in Tables 1700B and 1700C.

angle of bevel: See preferred term *bevel angle*.

arc blow: The deflection of an electric arc from its normal path because of magnetic forces.

arc length: The distance from the tip of the welding electrode to the adjacent surface of the weld pool.

arc strike: A discontinuity consisting of any localized remelted metal, heat-affected metal, or a change in the surface profile of any part of a weld or base metal resulting from an arc.

arc stud welding (SW): An arc welding process that uses an arc between a metal stud, or similar part, and the other workpiece. The process is used without filler metal, with or without shielding gas or flux, with or without partial shielding from a ceramic or graphite ferrule surrounding the stud, and with the application of pressure after the faying surfaces are sufficiently heated.

arc voltage: The voltage across the arc.

as-welded: The condition of weld metal, welded joints, and weldments after welding prior to any subsequent thermal, mechanical, or chemical treatments.

attenuation (UT): The loss in acoustic energy which occurs between any two points of travel. This loss may be due to absorption, reflection, etc. The attenuation factor for steel, using the shear wave pulse echo method of testing is 2 db per inch of sound path distance after the first inch.

attenuation (RT): The absorption of photons by the test material. This absorption is dependent upon the material thickness, density, and atomic nature.

automatic welding: Welding with equipment that requires only occasional or no observation of the welding, and no manual adjustment of the equipment controls.

axis of weld: See preferred term *weld axis*.

B

backgouging: The removal of weld metal and base metal from the weld root side of a welded joint to facilitate complete fusion and complete joint penetration.

backing: Material (steel or weld metal) placed at the root of a weld joint for the purpose of supporting molten weld metal.

backing pass: A weld pass made for a backing weld.

backing ring: Backing in the form of a ring, generally used in the welding of pipe.

backing strip: Backing in the form of a strip.

backing weld: Backing in the form of a weld.

bare electrode: A filler metal electrode that has been produced as a wire, strip, or bar with no coating or covering other than that incidental to its manufacture or preservation.

base metal: The metal or alloy to be welded or cut.

bevel: An angular type of edge preparation.

bevel angle: The angle formed between the prepared edge of a member and a plane perpendicular to the surface of the member.

blasting: A method of cleaning or surface roughening by a forcibly projected stream of sharp angular abrasive.

bolt to ship (BTS): Bolts marked 'BTS' shall be tightened wrench tight.

boxing: The continuation of a fillet weld around a corner of a member as an extension of the principal weld.

butt joint: A joint between two members aligned approximately in the same plane.

butt weld: A nonstandard term for a butt a weld in a butt joint. See *butt joint*.

C

caulking: Plastic deformation of weld and adjacent base metal surfaces by mechanical means to seal or obscure discontinuities.

chamfer: See preferred term *bevel*.

computer numerical control drilling (CNC): Holes marked CNC to be drilled full size unassembled by means of numerically controlled equipment.

match drill template (CNC-MDT): Holes marked CNC-MDT shall have one ply drilled full size using CNC, while remaining plies to be core drilled full size from solid using first (full size) ply as a one time template only. Prior to full size drilling, connecting parts shall be assembled and match marked.

cold crack: A crack which develops after solidification is complete. (Usually below 400° F).

complete fusion: Fusion over the entire fusion faces and between all adjoining weld beads.

complete joint penetration: A joint root condition in a groove weld in which weld metal extends through the joint thickness. (Joint penetration in which the weld completely fills the groove and is fused to the base metal throughout its total thickness).

complete joint penetration weld (CJP): A groove weld in which weld metal extends through the joint thickness.

complete penetration: See preferred term *complete joint penetration*.

concave fillet weld: A fillet weld having a concave face.

concavity: The maximum distance from the face of a concave fillet weld perpendicular to a line joining the weld toes.

consumable guide electroslag welding: See *electroslag welding*.

contact tube: A device that transfers current to a continuous electrode.

continuous weld: A weld which extends continuously from one end of a joint to the other. Where the joint is essentially circular, it extends completely around the joint.

convex fillet weld: A fillet weld having a convex face.

convexity: The maximum distance from the face of a convex fillet weld perpendicular to a line joining the weld toes.

core drill: A core drill uses a hollow bit to drill through steel. It is the preferred method of hole preparation for use on riveted bridge rehabilitation projects. Specifically, when field drilling new steel through existing rivet holes.

corner joint: A joint between two members located approximately at right angles to each other.

couplant (UT): A material (see Section 1708.3 for allowable couplants) used between the face of the ultrasonic search unit (transducer) and the test surface to permit or improve the transmission of the ultrasound between the search unit and the material under test.

crack: A fracture type discontinuity characterized by a sharp tip and high ratio of length and width to opening displacement. (See Appendix E)

crater: A depression in the weld face at the termination of a weld bead.

crater crack: See Appendix E.

D

Deputy Chief Engineer Structures (DCES): Deputy Chief Engineer Structures or an authorized representative. For projects not under the jurisdiction of the Department of Transportation, DCES shall mean the Building Commissioner, owner or owner's representative.

decibel (db) (UT): The logarithmic expression of a ratio of two amplitudes or intensities of acoustic energy.

decibel (db) rating (UT): See preferred term *indication rating*.

defect: A discontinuity or discontinuities which by nature or accumulated effect render a part or product unable to meet minimum applicable acceptance standards or specifications. This term designates rejectability.

defect level (UT): See preferred term *indication level*.

defect rating (UT): See preferred term *indication rating*

defective weld: A weld containing one or more rejectable discontinuities or defects.

delamination: See Appendix E.

deposited metal: Filler metal that has been added during a welding operation.

deposition rate: The weight of material deposited in a unit of time.

depth of bevel: The perpendicular distance from the base metal surface to the root edge or the beginning of the root face.

depth of fusion: The distance that fusion extends into the base metal or previous bead from the surface melted during welding.

dilution: The change in chemical composition of a welding filler metal caused by the admixture of the base metal or previously deposited weld metal in the deposited weld bead. It is normally measured by the percentage of base metal or previously deposited weld metal in the weld bead.

direct current electrode negative (DCEN): The arrangement of direct current arc welding leads in which the electrode is the negative pole and the workpiece is the positive pole of the welding arc.

direct current electrode positive (DCEP): The arrangement of direct current arc welding leads in which the electrode is the positive pole and the workpiece is the negative pole of the welding arc.

direct current reverse polarity: A nonstandard term for *direct current electrode positive*.

direct current straight polarity: A nonstandard term for *direct current electrode negative*

discontinuity: An interruption of the typical structure of a material, such as lack of homogeneity in its mechanical, metallurgical, or physical characteristics. A discontinuity is not necessarily a defect.

downhand: A nonstandard term for *flat position welding*.

drill in assembly (DA): Holes marked 'DA' shall be drilled full size from solid at assembly.

drill to template (DT): Holes marked 'DT' shall be core drilled full size using a template with hardened steel bushings. Prior to full size drilling, connecting parts shall be assembled and match marked.

direct tension indicators (DTI): DTI's are washer-shaped devices with 'bumps' on one face which are intended to flatten in a predictable manner such that Engineers can visually inspect bolts for proper tension in slip-critical or fully pre-tensioned bolted connections.

E

edge preparation: The preparation of the edges of the joint members by cutting, cleaning, plating, or other means.

effective throat: The minimum distance minus any convexity between the weld root and the face of a fillet weld.

electrode: A component of the welding circuit through which current is conducted to the arc, molten slag, or base metal.

electrode extension (SAW, FCAW, GMAW): The length of electrode extending beyond the end of the contact tube.

electrogas welding (EGW): An arc welding process which produces coalescence of metals by heating with an arc between a continuous filler metal (consumable) electrode and the workpiece. Molding shoe(s) are used to confine the molten metal for

vertical position welding. The electrodes may be either flux cored or solid. Shielding may or may not be obtained from an externally supplied gas or mixture.

electroslag welding (ESW): A welding process producing coalescence of metals with molten slag which melts the filler metal and the surfaces of the work to be welded. The molten weld pool is shielded by this slag which moves along the full cross section of the joint as welding progresses. The process is initiated by an arc which heats the slag. The arc is then extinguished and the conductive slag is maintained in a molten condition by its resistance to electric current passing between the electrode and the work. An alternate method uses a consumable guide, in which filler metal is supplied by an electrode and its guiding member.

F

face reinforcement: Weld reinforcement on the side of the joint from which welding was done.

faying surface: The mating surface of a member which is in contact or in close proximity with another member to which it is to be joined.

field weld: A weld made at a location other than a shop or the place of initial construction.

filler metal: The metal or alloy to be added in making a welded, brazed, or soldered joint.

fillet weld: A weld of approximately triangular cross section joining two surfaces approximately at right angles to each other in a lap joint, T-joint, or corner joint.

fillet weld break test: A test in which the specimen is loaded so that the weld root is in tension.

fillet weld leg: The distance from the root of the joint to the toe of the fillet weld.

finger tight: (FT) Same as HT. Bolt tightened manually by hand.

fissures: See Appendix E.

flare-bevel-groove weld: A weld in the groove formed by a member with a curved surface and another with a planar surface.

flare-V-groove weld: A weld in a groove formed by two members with curved surfaces.

flat welding position: The welding position used to weld from the upper side of the joint at a point where the weld axis is approximately horizontal, and the weld face lies in an approximately horizontal plane. See Sections 803 and 810.

flux: A material used to hinder or prevent the formation of oxides and other undesirable substances in molten metal and on solid metal surfaces, and to dissolve or otherwise facilitate the removal of such substances.

flux cored arc welding (FCAW): An arc welding process that uses an arc between a continuous filler metal electrode and the weld pool. The process is used with shielding gas from a flux contained within the tubular electrode, with or without additional shielding from an externally supplied gas, and with or without the application of pressure. (See Gas-shielded flux cored arc welding (FCAW-G) and Self-shielded flux cored arc welding (FCAW-S).

flux cored electrode: A composite tubular filler metal electrode consisting of a metal sheath and a core of various powdered materials, producing an extensive slag cover on the face of a weld bead. External shielding may be required.

fracture critical member (FCM): Fracture critical members are defined as tension members or tension components of non-redundant members whose failure would result in the collapse of the structure. Tension components include any member that is loaded axially in tension, or that portion of a flexural member that is subjected to tensile stress.

fusion: The melting together of filler metal and base metal, or the melting of base metal only, which results in coalescence. See *depth of fusion*.

fusion-type discontinuity: Signifies slag inclusion, incomplete fusion, incomplete joint penetration, and similar discontinuities associated with fusion.

fusion boundary: A nonstandard term for *weld interface*.

fusion zone: The area of base metal melted as determined on the cross section of a weld.

G

gas pocket: A nonstandard term for *porosity*.

gas-shielded flux cored arc welding (FCAW-G): A flux cored arc welding process variation in which shielding gas is supplied through the gas nozzle, in addition to that obtained from the flux within the electrode.

gouging: The forming of a bevel or groove by material removal. See *air carbon arc gouging*.

grind to fit (GF): Seventy-five percent of the projected bearing area shall be in contact within 0.01 inch (0.25 mm) with a permissible variation of $1/32$ inch (0.80 mm) for the remaining projected area.

groove angle: The total included angle of the groove between parts to be joined by a groove weld.

groove face: That surface of a joint member included in the groove.

groove radius: The radius used to form the shape of a J- or U- groove weld.

groove weld: A weld made in the groove between the workpieces.

groove weld size: The joint penetration of a groove weld.

groove weld throat: A nonstandard term for *groove weld size*.

H

hand tight (HT): Same as FT. Bolt tightened manually by hand.

H & D density: (Hurter & Driffield density) A method for measuring the degree of exposure of radiographs. The density is equal to the logarithm of the ratio of the light intensity incident on the film to the light intensity transmitted.

heat-affected zone (HAZ): That portion of the base metal whose mechanical properties or microstructure have been altered by the heat of welding, brazing, soldering, or thermal cutting.

heat-affected zone crack: See Appendix E.

heat input: The energy supplied by the welding arc to the workpiece.

heating torch: A device for directing the heating flame produced by the controlled combustion of fuel gases.

heat-shrink: A procedure for curving, straightening or cambering plates, beams, girders and other pieces or fabricated members by the controlled application of heat to specific locations in the piece. The dimensional change of the material results from the upset shortening of the steel in the heated area.

horizontal position: See *horizontal welding position*.

horizontal welding position, fillet weld: The welding position in which the weld is on the upper side of an approximately horizontal surface and against an approximately vertical surface.

horizontal welding position, groove weld: The welding position in which the weld face lies in an approximately vertical plane and the weld axis at the point of welding is approximately horizontal.

horizontal (zero) reference line (UT): A horizontal line near the center of the ultrasonic test instrument display to which all echoes are adjusted for db reading.

I

inadequate joint penetration: A nonstandard term for *incomplete joint penetration*.

inclusion: Entrapped foreign solid material, such as slag, flux, tungsten, or oxide.

incomplete fusion: A weld discontinuity in which fusion did not occur between weld metal and fusion faces or adjoining weld beads. See Appendix E.

incomplete joint penetration: A joint root condition in a groove weld in which weld metal does not extend through the joint thickness.

indication (UT): The signal displayed on the instrument display signifying the presence of a sound wave reflector in the part being tested.

indication level (UT): The calibrated gain or attenuation control reading obtained for a reference line height indication from a discontinuity.

indication rating (UT): The decibel (db) reading in relation to the zero reference level after having been corrected for sound attenuation.

intermittent weld: A weld in which the continuity is broken by recurring unwelded spaces.

interpass temperature, welding: In a multipass weld, the temperature (minimum or maximum as specified) of the weld area before the next pass is started.

J

joint: The junction of members or the edges of members that are to be joined or have been joined.

joint geometry: The shape and dimensions of a joint in cross section prior to welding.

joint penetration, groove weld: The distance the weld metal extends from the weld face into a joint, exclusive of reinforcement. See *groove weld size*.

joint root: That portion of a joint to be welded where the members approach closest to each other. In cross section, the joint root may be either a point, a line, or an area.

K

kerf: The width of the cut produced during a cutting process.

L

lack of fusion: A nonstandard term for *incomplete fusion*.

lamellar tearing: A subsurface terrace and step-like crack in the base metal with a basic orientation parallel to the wrought surface caused by tensile stresses in the through-thickness of the base metals weakened by the presence of small dispersed, planar shaped, nonmetallic inclusions parallel to the metal surface. See Appendix E.

lamination: A type of discontinuity with separation or weakness generally aligned parallel to the worked surface of a metal. See Appendix E.

land: A nonstandard term for *root face*.

lap joint: A joint between overlapping members in parallel planes.

laps: See Appendix E.

layer: A stratum of weld metal consisting of one or more weld beads.

leg (UT): The path the shear wave travels in a straight line before being reflected by the material being tested. See sketch for leg identification. Note: (Leg 1) + (Leg 2) = 1 V-Path

leg of fillet weld: See *fillet weld leg*.

linear discontinuity: A discontinuity with a length that is substantially greater than its width.

longitudinal crack: A crack with its major axis orientation approximately parallel to the weld axis. See Appendix E

M

machine welding: A nonstandard term when used for *mechanized welding*.

macro-etch test: A test in which a specimen is prepared with a fine finish, etched, and examined under low magnification.

manual welding: Welding with the torch, gun, or electrode holder held and manipulated by hand. Accessory equipment, such as part motion devices and manually controlled material feeders may be used.

mechanized welding: Welding with equipment that requires manual adjustment of the equipment controls in response to visual observation of the welding, with the torch, gun, or electrode holder held by a mechanical device. See also *automatic welding*, *manual welding*, and *semi-automatic welding*.

mechanized thermal cutting: See *mechanized welding*.

metal cored electrode: A composite tubular filler metal electrode consisting of a metal sheath and a core of various powdered materials, producing no more than slag islands on the face of a weld bead. External shielding may be required.

mill to bear (MB): One hundred percent of the projected bearing area shall be in contact.

N

node (UT): See preferred term *leg*.

nondestructive examination (NDE): The act of determining the suitability of some material or component for its intended purpose using techniques that do not affect its serviceability.

O

overhead welding position: The position in which welding is performed from the underside of the joint. See Sections 803 and 810.

overlap: The protrusion of weld metal beyond the weld toe or weld root. See Appendix E.

oxygen cutting (OC): A group of thermal cutting processes that severs or removes metal by means of the chemical reaction between oxygen and the base metal at elevated temperature. The necessary temperature is maintained by the heat of an oxyfuel gas flame, or other source.

P

parallel electrode: Two electrodes connected electrically in parallel and exclusively to the same power source. Both electrodes are usually fed by means of a single electrode feeder. Welding current, when specified, is the total for the two electrodes.

partial joint penetration weld (PJP): A joint root condition in a groove weld in which incomplete joint penetration exists. See *complete joint penetration weld, incomplete joint penetration*.

pass: See preferred term *weld pass*.

peening: The mechanical working of metals using impact blows.

penetrameter (IQI): A radiographic image quality indicator (IQI). See Section 1604.2.5 for a description of the required penetrameters.

penetration: A nonstandard term when used for *depth of fusion, joint penetration, or root penetration*.

plasma arc cutting (PAC): An arc cutting process that uses a constricted arc and removes the molten metal with a high-velocity jet of ionized gas issuing from the constricting orifice.

pipng porosity: See Appendix E.

plug weld: A weld made in a circular hole in one member of a joint fusing that member to another member. The walls of the hole may not be parallel and the hole may be partially or completely filled with weld metal. A fillet welded hole or a spot weld should not be construed as conforming to this definition.

porosity: Cavity type discontinuities formed by gas entrapment during solidification. See Appendix E.

positioned weld: A weld made in a joint which has been so placed as to facilitate making the weld.

postweld heat treatment: Any heat treatment subsequent to welding.

preheat: The heat applied to the base metal or substrate to attain and maintain preheat temperature.

preheat temperature (thermal cutting): The temperature of the base metal in the volume surrounding the point of thermal cutting immediately before thermal cutting is started.

preheat temperature (welding): The temperature of the base metal in the volume surrounding the point of welding immediately before welding is started. In a multipass weld, it is also the temperature immediately before the second pass and subsequent passes are started.

prequalified welding procedure specification: A welding procedure specification that complies with the stipulated conditions of a particular welding code or specification and is therefore acceptable for use under that code or specification without a requirement for qualification testing.

primary members: Primary members are defined as: Structural elements that are designed to carry live load and act as primary load paths. Examples include: truss chords, girders, floor beams, stringers, arches, towers, bents, rigid frames, and tub and curved girder diaphragms. Additionally, lateral connection plates welded to the members listed above; and hangers, connection plates, and gusset plates which support the members listed above are also primary members.

procedure qualification: The demonstration that welds made by a specific procedure can meet the prescribed standards. See *welding procedure qualification record (WPQR)*.

Q

qualification: See preferred terms *procedure qualification* or *welder performance qualification*.

R

ream in assembly (RA): Holes marked 'RA' shall be sub-punched or sub-drilled 1/4" undersize and reamed to full size with connecting parts assembled and match marked

reference level (UT): The decibel (db) reading obtained for a horizontal reference line height indication from a reference reflector.

reference reflector (UT): The reflector of known geometry contained in the IIW Reference Block or other approved blocks.

reinforcement of weld: See preferred term *weld reinforcement*.

rejectable discontinuity: See preferred term *defect*.

residual stress: Stress present in a joint member or material that is free of external forces or thermal gradients. Stress arises in fusion welding because the weld metal contracts on cooling from the solidus to room temperature.

resolution (UT): The ability of ultrasonic equipment to distinguish separate indications from closely spaced reflectors.

reverse polarity: A nonstandard term for *direct current electrode positive (DCEP)*.

root crack: See Appendix E.

root face: That portion of the groove face within the joint root.

root opening: A separation at the joint root between the workpieces.

root pass: A weld deposit that extends into or includes part or all of the root of the joint.

root penetration: The distance the weld metal extends into the joint root.

root reinforcement: Weld reinforcement opposite the side from which welding was done.

rotational capacity tested bolts (RTC)

S

scanning level (UT): The (db) setting used during scanning, as described in Tables 1700 B & C. (Sensitivity + Additional db for metal path).

secondary members: Secondary members are defined as those structural elements which do not carry primary stress or act as primary load paths.

seal weld: Any weld designed primarily to provide a specific degree of tightness against leakage.

self-shielded flux cored arc welding (FCAW-S): A flux cored arc welding process variation in which shielding gas is obtained exclusively from the flux within the electrode.

semiautomatic welding: Manual welding with equipment that automatically controls one or more of the welding conditions. See also *automatic welding*, *manual welding*, and *mechanized welding*.

shielded metal arc welding (SMAW): An arc welding process with an arc between a covered electrode and a weld pool. The process is used with shielding from the decomposition of the electrode covering, without the application of pressure, and with filler metal from the electrode.

shielding gas: Protective gas used to prevent or reduce atmospheric contamination.

shrinkage stress: A nonstandard term when used for *residual stress*.

single electrode: One electrode connected exclusively to one power source which may consist of one or more power units.

size of weld: See preferred term *weld size*.

slag: A nonmetallic product resulting from the mutual dissolution of flux and nonmetallic impurities in some welding and brazing processes.

slag inclusion: Oxides and other nonmetallic solids entrapped in weld metal or between weld metal and base metal. Slag inclusions generally result from the failure to remove slag between beads and layers of multipass welds, from improper manipulation of the electrode or from failure to provide a proper contour on which each weld bead is deposited.

slot weld: A weld made in an elongated hole in one member of a joint fusing that member to another member. The hole may be open at one end. A fillet welded slot is not to be construed as conforming to this definition.

spatter: The metal particles expelled during fusion welding that do not form part of the weld.

spray transfer, arc welding: Metal transfer in which molten metal from a consumable electrode is propelled axially across the arc in small droplets.

snug tight (ST): Same as WT. Snug tight is defined as the tightness attained by a few impacts of an impact wrench or the full effort of an ironworker using an ordinary spud wrench to bring the connected plies into firm contact.

sound beam distance (UT): See preferred term *sound path distance*.

sound path distance (UT): The distance between the search unit, test material interface, and the reflector as measured along the centerline of the sound beam.

stickout, gas metal arc welding (GMAW) and gas-shielded flux cored arc welding (FCAW-G): The length of unmelted electrode extending beyond the end of the gas nozzle.

straight polarity: A nonstandard term for *direct current electrode negative (DCEN)*.

stress-corrosion cracking: Failure of metals by cracking under combined action of corrosion and stress, residual or applied.

stress relief heat treatment: Uniform heating of a structure or a portion thereof to a sufficient temperature to relieve the major portion of the residual stresses, followed by uniform cooling.

stringer bead: A type of weld bead made without appreciable weaving motion. See also *weave bead*.

stud (shear connector) base: The stud (shear connector) tip at the welding end, including flux and container, and $\frac{1}{8}$ inch of the body of the stud adjacent to the tip.

stud welding: A nonstandard term for *arc stud welding*.

submerged arc welding (SAW): An arc welding process that uses an arc or arcs between a bare metal electrode or electrodes and the weld pool. The arc and molten metal are shielded by a blanket of granular flux on the workpieces. The process is used without pressure and with filler metal from the electrode and sometimes from a supplemental source (welding rod, flux, or metal granules).

surface preparation: The operations necessary to produce a desired or specified surface condition.

T

tack weld: A weld made to hold parts of a weldment in proper alignment until the final welds are made.

tacker: A nonstandard term for *tack welder*.

tack welder: A fitter, or someone under the direction of a fitter, who tack welds part of a weldment to hold them in proper alignment until the final welds are made.

tandem: Refers to a geometrical arrangement of electrodes in which a line through the arcs is parallel to the direction of welding..

tee joint: A joint between two members located approximately at right angles to each other in the form of a 'T'.

temporary weld: A weld made to attach a piece or pieces to a weldment for temporary use in handling, shipping, or working on the weldment.

tension control bolt / twist-off-type tension-control bolt. (TCB): Tension control bolt-nut-washer assemblies are capable of developing a minimum predetermined tension when installed by applying torque to the nut, while at the same time applying a counter torque to separate the spline end from the body of the bolt using an appropriate spline drive installation tool. This bolt type is NOT allowed by NYSDOT.

theoretical throat (design throat): The distance from the beginning of the joint perpendicular to the hypotenuse of the largest right triangle that can be inscribed within the cross section of a fillet weld. This dimension is based on the assumption that the root opening is equal to zero.

thermal cutting (TC): A group of cutting processes that severs or removes metal by localized melting, burning, or vaporizing of the workpieces. See *plasma arc cutting* and *oxygen cutting*.

thermal stress: Stress resulting from non-uniform temperature distribution

throat crack: See Appendix E.

tight fit: Fifty percent of the projected bearing area shall be in contact within 0.02 inch (0.5 mm) with a permissible variation of $\frac{1}{16}$ inch (1.6 mm) for the remaining 50 percent of the projected area.

toe crack: See Appendix E.

transverse crack: A crack with its major axis oriented approximately perpendicular to the weld axis. See Appendix E.

U

underbead crack: A crack in the heat-affected zone (HAZ) generally not extending to the surface of the base metal. See Appendix E.

undercut: A groove melted into the base metal adjacent to the weld toe or weld root and left unfilled by weld metal. See Appendix E.

underfill: A condition in which the weld face or root surface extends below the adjacent surface of the base metal. See Appendix E.

uphill: Welding with an upward progression.

V

vee path (UT): The distance a shear wave sound beam travels from the search unit test material interface to the other face of the test material and back to the original surface

vertical position: The position of welding in which the axis, at the point of welding, is approximately vertical, and the weld face lies in an approximately vertical plane. See Sections 803 and 810.

vertical up: A nonstandard term for uphill.

W

weathering steel: Steel with a chemical composition such that its oxidation product (rust) acts as a protective coating and the steel is designated by the Contract Documents to remain unpainted.

weave bead: A type of weld bead made with transverse oscillation.

weld: A localized coalescence of metals produced by either heating to suitable temperatures, with or without the application of pressure or by the application of pressure alone, and with or without the use of filler metal.

weldability: The capacity of a metal to be welded under the imposed fabrication conditions into a specific, suitably designed structure and to perform satisfactorily in the intended service.

weld axis: A line through the length of the weld, perpendicular to and at the geometric center of its cross section.

weld bead: A weld deposit resulting from a pass.

welder: One who performs a manual or semiautomatic welding operation. (Sometimes erroneously used to denote a welding machine).

welder certification: Written verification that a welder has produced welds meeting prescribed standards.

welder performance qualification: The demonstration of a welder's ability to produce welds meeting prescribed standards.

welding: A joining process that produces coalescence of materials by heating them to the welding temperature, with or without the application of pressure or by the application of pressure alone, and with or without the use of filler metal.

welding current: The current in the welding circuit during the making of a weld.

welding machine: Equipment used to perform the welding operation.

welding operator: One who operates adaptive control, automatic, mechanized, or robotic welding equipment.

welding procedure: The detailed methods and practices including all joint welding procedures involved in the production of a weldment. See also *welding procedure specification*.

welding procedure qualification record (WPQR): A document providing the actual welding variables used to produce an acceptable test weldment and the results of tests conducted on the weldment for the purposes of qualifying a welding procedure specification.

welding procedure specification (WPS): A document providing in detail the required variables for a specific application to assure repeatability by properly trained welders and welding operators.

welding process: See *welding*

weld interface: The interface between weld metal and base metal in a fusion weld.

weld metal: The portion of a fusion weld which has been completely melted during welding.

weld pass: A single progression of welding along a joint. The result of a pass is a weld bead or layer.

weld reinforcement: Weld metal in excess of the quantity required to fill a joint.

welding sequence: The order of making the welds in a weldment.

weld size:

groove weld: The joint penetration (depth of bevel plus the root penetration when specified). The size of a groove weld and its joint penetration are one and the same.

fillet weld: For equal leg fillet welds, the leg length of the largest isosceles right triangle that can be inscribed within the fillet weld cross section. For unequal leg fillet welds, the length of the largest right triangle that can be inscribed within the fillet weld cross section.

NOTE: When one member makes an angle with the other member greater than 105 degrees, the leg length (size) is of less significance than the effective throat which is the controlling factor for the strength of a weld.

welding technique: The details of a welding procedure that are controlled by the welder or welding operator.

weldment: An assembly whose component parts are joined by welding.

weld throat: See actual throat, effective throat, and theoretical throat.

weld toe: The junction of the weld face and the base metal.

wire feed speed: The rate at which wire is consumed in arc cutting, thermal spraying, or welding.

workpiece: The part that is welded, brazed, soldered, thermal cut, or thermal sprayed.

wrench tight (WT): Same as ST. The wrench tightened condition is the tightness that is attained with a few impacts of an impact wrench, or the full effort of an ironworker using an ordinary spud wrench to bring the connected plies into firm contact.

Notes:

APPENDIX E

DESCRIPTION OF COMMON WELD AND BASE METAL DISCONTINUITIES

E1. GENERAL

This appendix describes discontinuities which may or may not be classified as defects under the provisions of this Manual. Except for cracks, discontinuities are rejectable only if they exceed the specification requirements for type, size, distribution or location. All cracks are rejectable discontinuities under the provisions of this Manual. Discontinuities may be found in the base metal, weld metal, or heat-affected zones in butt, tee, corner and lap joint configurations. The following section present a fairly comprehensive list of discontinuities which may be encountered in fabrication.

E2. LIST OF DISCONTINUITIES

The most common types of discontinuities found in butt, tee, corner and lap joints are listed in Table E1 and shown in Figures E1 thru E6.

Weld and base metal discontinuities of specific types are more common when certain welding processes and joint details are used. High restraint and limited access to portions of a weld joint preparation may lead to a higher than normal incidence of weld and base metal discontinuities.

Each general type of discontinuity is discussed in detail in this appendix. The Steel Construction Manual and the AWS Structural Welding Code use the term "fusion type discontinuity" as an all encompassing term to describe slag inclusions, incomplete fusion, inadequate joint penetration and similar generally elongated discontinuities in weld fusion.

Since the Manual requires all complete joint penetration welds without backing to be back gouged to sound-metal before welding from the second side, inadequate joint penetration is technically impossible if all provisions of the Manual are met. Many codes consider fusion discontinuities less critical than cracks. The Manual reflects our agreement with this provision. Some codes specifically prohibit not only cracks, but also any area of incomplete fusion or inadequate joint penetration. The Manual does not prohibit incomplete fusion or inadequate joint penetration, per se, even though these discontinuities are planar defects that, in a fracture analysis, will perform in a manner similar to cracks. Incomplete fusion and inadequate joint penetration defects are treated as fusion discontinuities since they generally do not have the flaw tip acuity of a crack and because routine-nondestructive tests generally cannot distinguish between the various types of fusion defects.

Specific joint types and welding procedures may have an effect on the type, location and incidence of discontinuities. The conditions that may effect the formation of discontinuities are described in the following subsections.

- 1) **Porosity.** Porosity is created when gas is entrapped in solidifying metal. The discontinuity formed is generally spherical but may be elongated. When there are gas discontinuities in ingots that are reduced to wrought products, gas voids in the ingot will appear as laminations in the finished product. This appendix will only discuss porosity as a weld discontinuity. Unless porosity is gross (large and/or extensive), it is not as critical a flaw as sharp, planar discontinuities that intensify stress. Porosity is a sign that the welding process is not being properly controlled or that the base metal is contaminated or of variable composition. Porosity is not caused exclusively by hydrogen, but the presence of porosity indicates that there is a possibility of hydrogen in the weld and heat affected zone that may lead to cracking.

- a) **Uniformly Scattered Porosity.** Uniformly scattered porosity is scattered pores distributed throughout a single weld pass or throughout several passes of a multiple pass weld. Whenever uniformly scattered porosity is encountered, the cause is generally faulty welding technique or materials. Porosity will only be present in a weld if the technique used, materials or the conditions of the weld joint preparation lead to gas formation and entrapment. If the weld cools slowly enough to allow gas to pass to the surface before solidification, there will be no porosity in the weld.
 - b) **Cluster Porosity.** Cluster porosity is a localized grouping of pores that usually results from improper initiation or termination of the welding arc.
 - c) **Linear Porosity.** Linear porosity is porosity (pores) aligned along a joint boundary, the root of the weld, or an interbead boundary. Linear porosity is caused by contamination that leads to gas evolution at particular locations within the weld.
 - d) **Piping Porosity.** Piping porosity is a term for elongated (cylindrical) gas discontinuities. Piping porosity in fillet welds extends from the root of the weld towards the surface of the weld. When one or two pores are seen in the surface of the weld, careful excavation will generally show that there are many subsurface piping porosity discontinuities interspersed among the exposed pores. Much of the piping porosity found in welds does not extend all the way to the surface. Piping porosity in electroslag and electrogas welds can become very extensive in number and length. Pores as long as twenty inches have been measured in some welds.
- 2) **Inclusions.**
- a) **Nonmetallic Slag.** Slag inclusions result from nonmetallic, solid material being entrapped in weld metal, between weld passes, or between weld and base metal. Slag inclusions can be found in welds made by most arc welding procedures. In general, slag inclusions result from faulty welding technique, failure to clean properly between weld passes, and conditions that lead to limited access for welding within the joint. If allowed, molten slag will flow to the top of the Weld. Sharp notches in joint boundaries or between weld passes often cause slag to be entrapped under the molten weld metal.
 - b) **Metallic Tungsten.** Tungsten inclusions are only found in welds made by the gas tungsten arc welding process. Since this process is not used under the provisions of this Manual, the discontinuity is listed for interest only. Tungsten inclusions may be found in aluminum welds made by the gas tungsten arc welding process. A non-consumable tungsten electrode is used to establish a welding arc between the electrode and the base metal. If the tungsten electrode is dipped into the molten metal, or if the current is set to high, tungsten droplets maybe transferred from the electrode to the molten metal. Tungsten inclusions appear as light marks or areas in radiographs because the inspecting radiation has a higher absorption rate in tungsten than it does in steel or aluminum.
- 3) **Incomplete Fusion.** Incomplete fusion may result from improper welding techniques, improper preparation of materials for welding, or improper joint design. Deficiencies causing incomplete fusion include insufficient welding heat, improper electrode manipulation, or lack of access to all boundaries of the weld joint that are to be fused during welding. On rare occasions, weld metal may fail to fuse to the base metal even though the prepared joint surface has been melted beyond the original interface. Tightly adhering oxides will interfere with complete fusion, even when there is access for welding and proper welding procedures are used.

- 4) **Inadequate Joint Penetration.** Inadequate joint penetration is penetration of the welding arc that is less than required. Technically, this discontinuity may only be present when the welding procedure specification requires penetration of the weld metal beyond the original joint boundaries and the weld deposit fails to penetrate the areas of weld joints that depend upon penetration for fusion. Inadequate joint penetration may result from insufficient welding heat, improper electrode manipulation or guidance, or improper joint design which requires melting of more base metal than the arc can penetrate. Some welding procedures have much greater penetrating ability than others. This manual requires that all complete joint penetration groove welds without backing be back gouged to sound metal before welding from the second side so that there is no possibility of inadequate joint penetration at the root of the weld. In bridge construction, weld joint designs calling for specific root penetration to produce complete joint penetration groove welds are not used.
- 5) **Undercut.** Undercut considered to be a defect is generally the result of either an improper welding technique, excessive welding heat or both. It is generally located at the junction of the weld and base metal at the toe of fillet welds or at the fusion line of groove welds. Undercut may also be encountered at the root of groove welds made from one side only. Undercut creates a mechanical notch at the fusion boundary of the weld. All welds have some undercut if examined carefully. Undercut is not considered a weld defect until the degree of undercutting exceeds the amount allowed by the Contract Documents. Some undercut produces a sharp notch defect. Other undercutting may be more rounded. Some undercut may only be seen in metallographic tests where etched weld cross sections are examined under magnification. The sharper and deeper the notch created by undercutting, the more serious the defect.
- 6) **Underfill.** Underfill is the depression on the face of the weld extending below the surface of the adjacent base metal. Underfill results from the failure of the welder or welding operator to completely fill the weld joint as required by the welding procedure specification.
- 7) **Overlap.** Overlap is a sharp surface connected discontinuity that forms a severe mechanical notch when the weld metal protrudes or flows beyond the toe or face of the weld without fusion. It can occur as a result of failure to control the welding process, improper selection of welding materials, or improper preparation of the base metal prior to welding. Tightly adhering oxides on the base metal may interfere with fusion and overlap may result.
- 8) **Laminations.** Laminations are planar discontinuities elongated in the rolling direction. They are most commonly found near the mid-thickness of wrought products. Laminations may be completely internal and detectable only by nondestructive tests, or they may extend to an edge or end where they are visible at the surface. Laminations may be discovered when cutting or machining exposes internal laminations. Laminations are formed when gas voids (porosity), non-metallics, or the ingot shrinkage cavity are rolled flat. Laminations generally run parallel to the surface of rolled products and are most commonly found in shapes and plates. Some laminations are partially roll-forge welded along their interface by the high temperature and pressure of the rolling or forging operation. The soundness of the roll-forged weld depends upon the presence or absence of oxides or non-metallics on the surfaces of the original voids. Laminations that are partially or completely roll-forge welded may conduct sound across the interface and therefore may not be accurately evaluated by ultrasonic tests. Metals containing laminations generally cannot be relied upon to transmit tensile stresses in the thru-thickness direction. Laminations may be a source of gas voids and cracks in adjacent butt welds.
- 9) **Delamination.** Delamination is the separation of a partially or completely roll-forge welded lamination under stress. The stress may be residual stress from welding or applied stress. Delaminations may be found visually at the edges or ends of pieces or may be discovered by ultrasonic tests.
- 10) **Seams and Laps.** Seams and laps are longitudinal base metal discontinuities that may be found in rolled products. When seams and laps are located parallel to the principal stress, they are generally not considered critical defects. When seams or laps are perpendicular to the applied or residual stresses,

they will often propagate as cracks. Seams and laps are surface connected discontinuities that result from cracks in the surface of the ingot or mechanical deformations resulting from the manufacturing process. These discontinuities are modified during rolling so that the bottom of a seam is generally not as sharp as the original ingot or slab crack. They may be masked by mill scale or the surface texture of the finished product. Welding over seams and laps can lead to cracking.

- 11) **Lamellar Tears.** Lamellar tears are generally terrace-like separations in the base metal adjacent to the heat affected zone, typically caused by thermally induced shrinkage stresses resulting from welding. Lamellar tearing is a form of fracture resulting from high stress in the short-transverse (thru thickness) direction which may extend over long distances. The tears are roughly parallel to the surface of the rolled product and generally initiate in regions of the base metal having a high incidence of coplanar, stringer-like non-metallic inclusions and/or in areas of the base metal subject to high residual stress. The fracture usually propagates from one lamellar plane to another by shear along lines that are roughly normal to the rolled surface.
- 12) **Cracks.** Cracks occur in weld and base metal when localized stresses exceed the ultimate strength of the material. Cracking is generally associated with stress amplification near discontinuities in welds and base metal, or near mechanical notches associated with weldment design. High residual stresses are generally present and hydrogen embrittlement is often a contributor to crack formation. Welding related cracks are generally brittle in nature, exhibiting little plastic deformation at the crack boundaries.

Cracks can be classified as either hot cracks or cold cracks. Hot cracks develop at elevated temperatures. They commonly form upon solidification of the metal at temperatures near the melting point. Hot cracks propagate along grain boundaries. Cold cracks develop after solidification is complete. Cold cracks, sometimes called delayed cracks or hydrogen cracks, can form hours and even months after the completion of welding, and are commonly associated with hydrogen embrittlement. Cold cracks propagate both between and through the grains. Cracks maybe termed longitudinal or, transverse depending upon their orientation.

- a) **Longitudinal Cracks.** When a crack is parallel to the axis of the weld, it is called a longitudinal crack regardless of whether it is along the centerline of the weld metal, or in the heat affected zone of the base metal. Longitudinal cracks in submerged arc welds, made by automatic welding procedures, are often associated with high welding speeds and sometimes aggravated by segregation of weld metal constituents and/or extensive porosity that does not show on the surface of the weld. Longitudinal cracks in small welds between heavy sections are often the result of high cooling rates and high restraint.
- b) **Transverse Cracks.** Transverse cracks are perpendicular to the axis of the weld. They may be in weld metal, base metal, or both. Transverse cracks may be limited in size and contained completely within the weld, or may propagate from the weld metal into the adjacent heat affected zone and into the unaffected base metal. Transverse cracks initiating in weld metal are commonly the result of longitudinal shrinkage stresses acting upon excessively hard (brittle) weld metal. Transverse cracks initiating in the heat affected zone are generally hydrogen cracks.
- c) **Crater Cracks.** Crater cracks are cracks that form in the crater or depression that is formed by improper termination of the welding arc. Crater cracks are shallow hot cracks that usually form a multi-pointed star-like cluster, although they may have other shapes.
- d) **Throat Cracks.** Throat cracks are longitudinal cracks that are generally located in the center of the weld bead. They are generally, but not always, hot cracks.
- e) **Toe Cracks.** Toe cracks are generally cold cracks. They initiate or propagate from the toe of the weld where restraint stresses are highest. Toe cracks initiate approximately normal to the base

metal surface and propagate to various depths in the base metal depending upon the residual stress and toughness of the base metal.

- f) **Root Cracks.** Root cracks are generally longitudinal cracks in the root of the weld. Root cracks are generally hot cracks.
- g) **Underbead and Heat Affected Zone Cracks.** Underbead and heat affected zone cracks are almost always cold cracks that form in the heat affected zone. They are generally short cracks, but may join to form much larger continuous cracks. Underbead and heat affected zone cracks generally align themselves with weld boundaries that concentrate residual stresses. Underbead cracking and all other hydrogen cracks can become a serious problem when three elements are present; a susceptible microstructure, high residual stress and hydrogen.
- h) **Fissures.** The term fissure is used to describe small to moderate size separations along prior austenite grain boundaries. This discontinuity is commonly found in electroslag and electrogas welds. Fissures occur in other welds, but they are easier to detect in electroslag welds because of the much larger prior austenite grain size. When electroslag welds are subject to high restraint, and hydrogen is present, fissuring may become a major problem. Fissuring in electroslag and electrogas welds is generally restricted to the center portion of the weld that is subject to high tensile residual stress resulting from solidification. Fissures can be either hot or cold cracks, although cold cracking is more common. The term microfissure is used for cracks that are so small that magnification must be used to detect the separation. The term macrofissure is used when the separation is large enough to be seen with the unaided eye.

Table E1 – COMMON TYPES OF DISCONTINUITIES

Type of discontinuity	Location	Remarks
1) Porosity a) Uniformly scattered b) Cluster c) Linear d) Piping	W	Weld only, as discussed herein. (Porosity is also commonly found in castings.)
2) Inclusions a) Non-metallic slag b) Metallic tungsten	W	
3) Incomplete fusion (also called lack of fusion)	W	Found at joint boundaries or between passes.
4) Inadequate joint penetration (also called lack of joint penetration)	W	Found at root of weld preparation.
5) Undercut	BM	Found at junction of weld and base metal at surface.
6) Underfill	W	Found at outer surface of joint preparation.
7) Overlap	W	Found at junction of weld and base metal at surface.
8) Laminations	BM	Found in base metal, generally near mid-thickness of section.
9) Delamination	BM	Found in base metal, generally near mid-thickness of section.
10) Seams and Laps	BM	Found at base metal surface. Almost always longitudinal.
11) Lamellar tears	BM	Found in base metal near weld HAZ.
12) Cracks a) Longitudinal b) Transverse c) Crater d) Throat e) Toe f) Root g) Underbead and Heat Affected Zone h) Fissures	W,HAZ,BM W,HAZ,BM W W HAZ W HAZ W	Found in weld or base metal adjacent to weld fusion boundary. Found in weld (may propagate from weld into HAZ and base metal). Found in weld at point where arc is terminated. Found at weld axis. Found at junction between face of weld and base metal. Found in weld metal at root. Found in base metal in HAZ (may propagate into unaffected base metal) Found in weld metal
W-weld BM-base metal HAZ-heat affected zone		

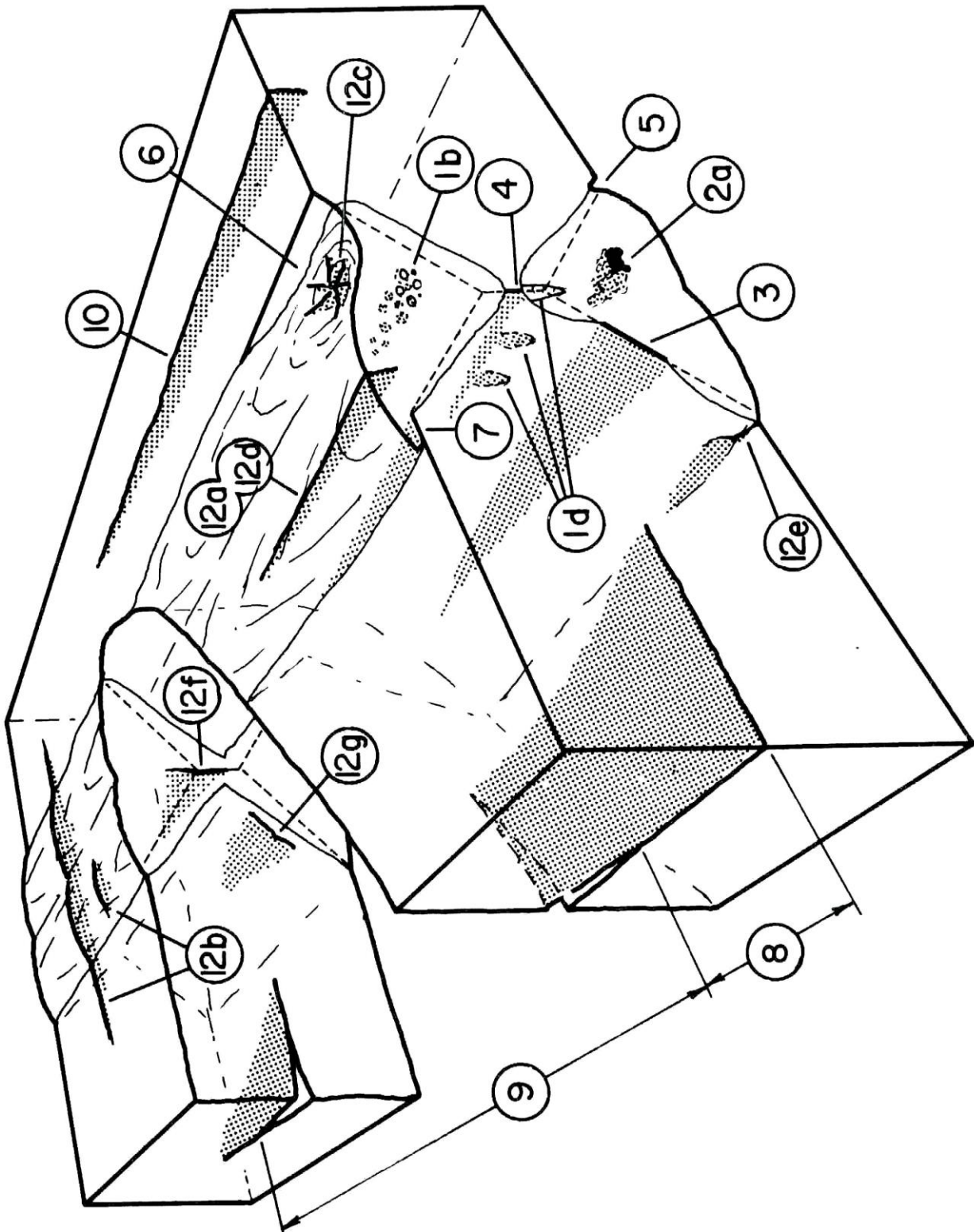

FIGURE E 1 – WELD IN BUTT JOINT

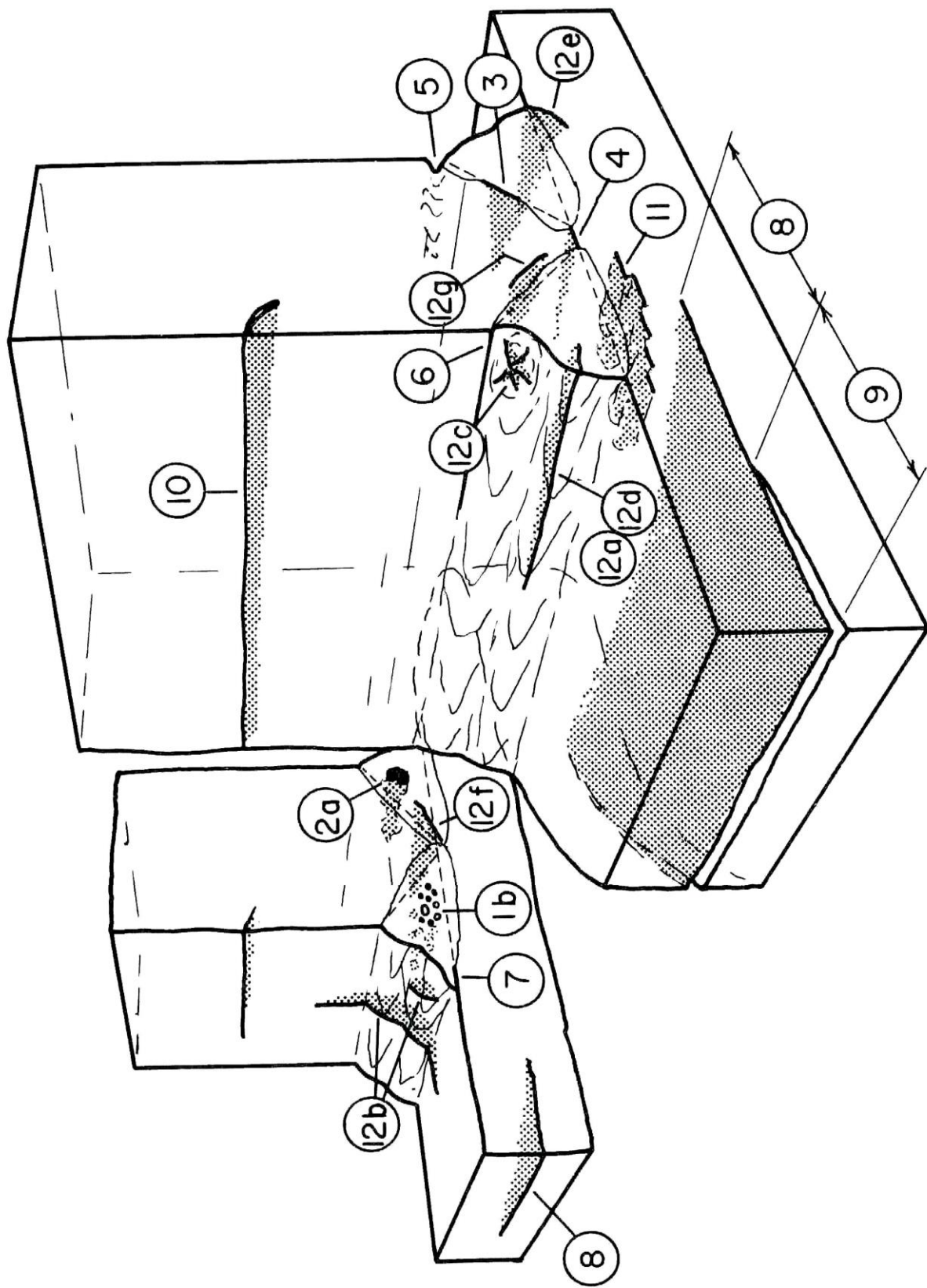

FIGURE E 3 - WELD IN TEE JOINT

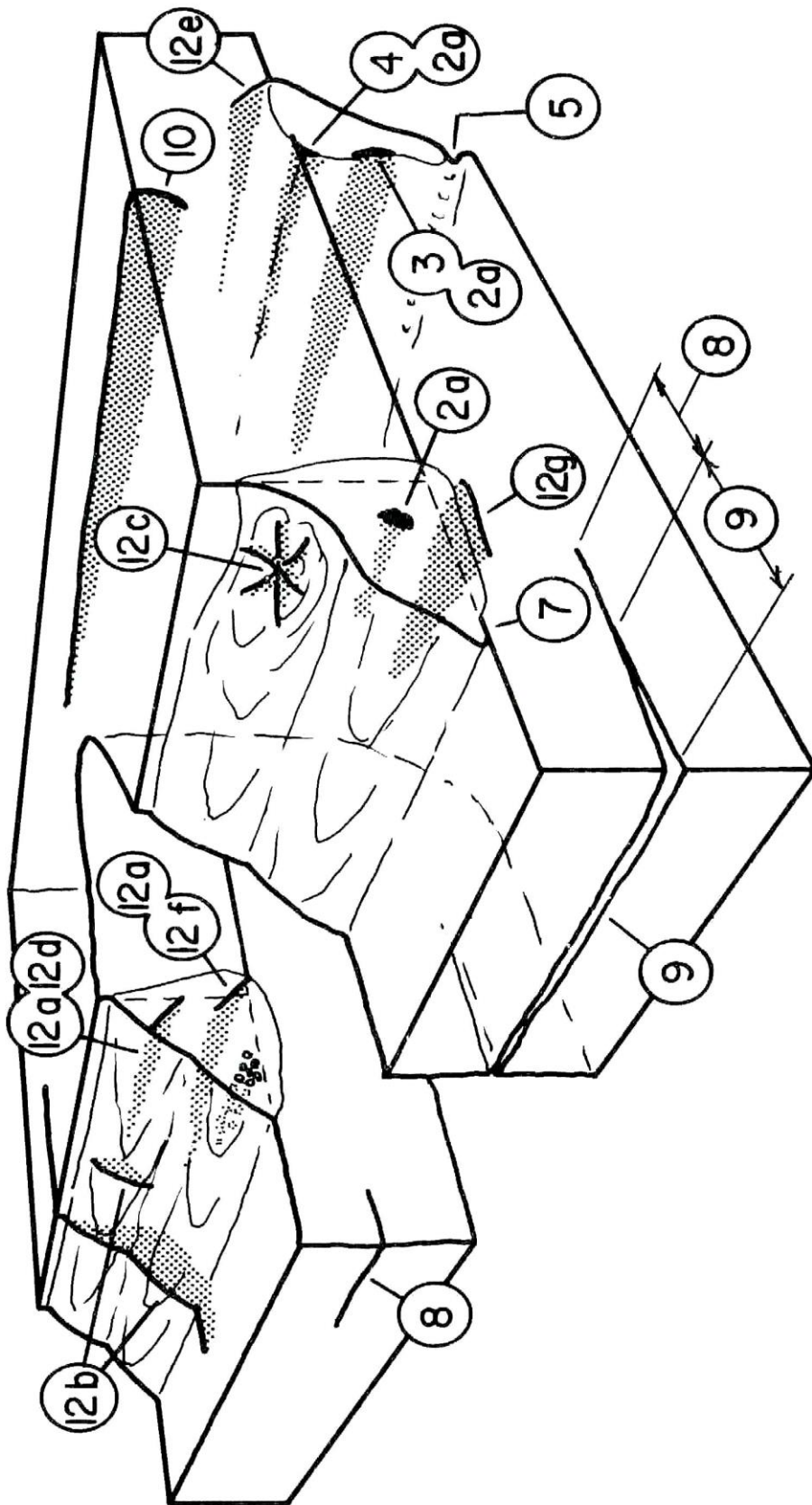

FIGURE E 4 – WELD IN LAP JOINT

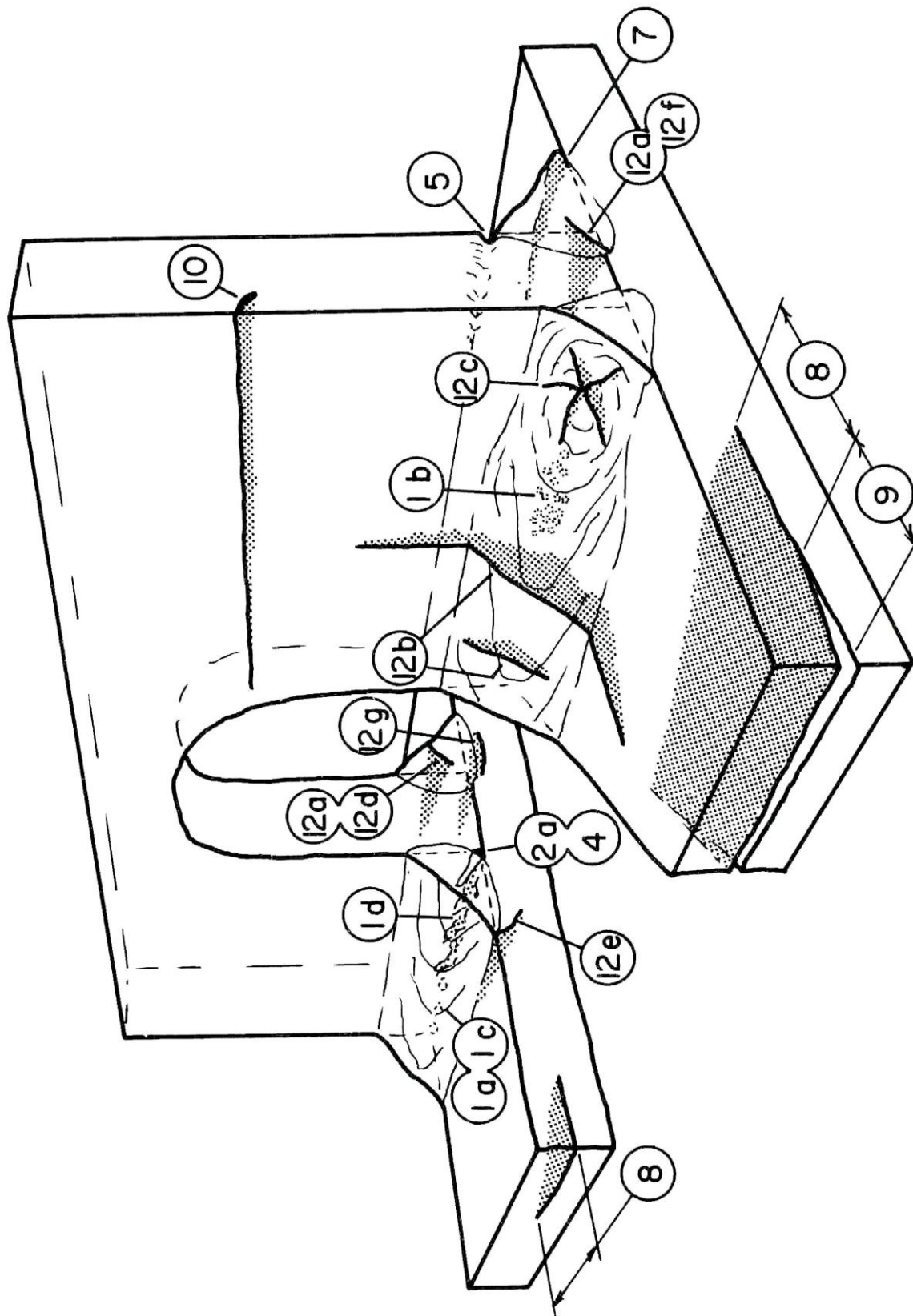

FIGURE E 5 – SINGLE PASS FILLET WELD IN A TEE JOINT

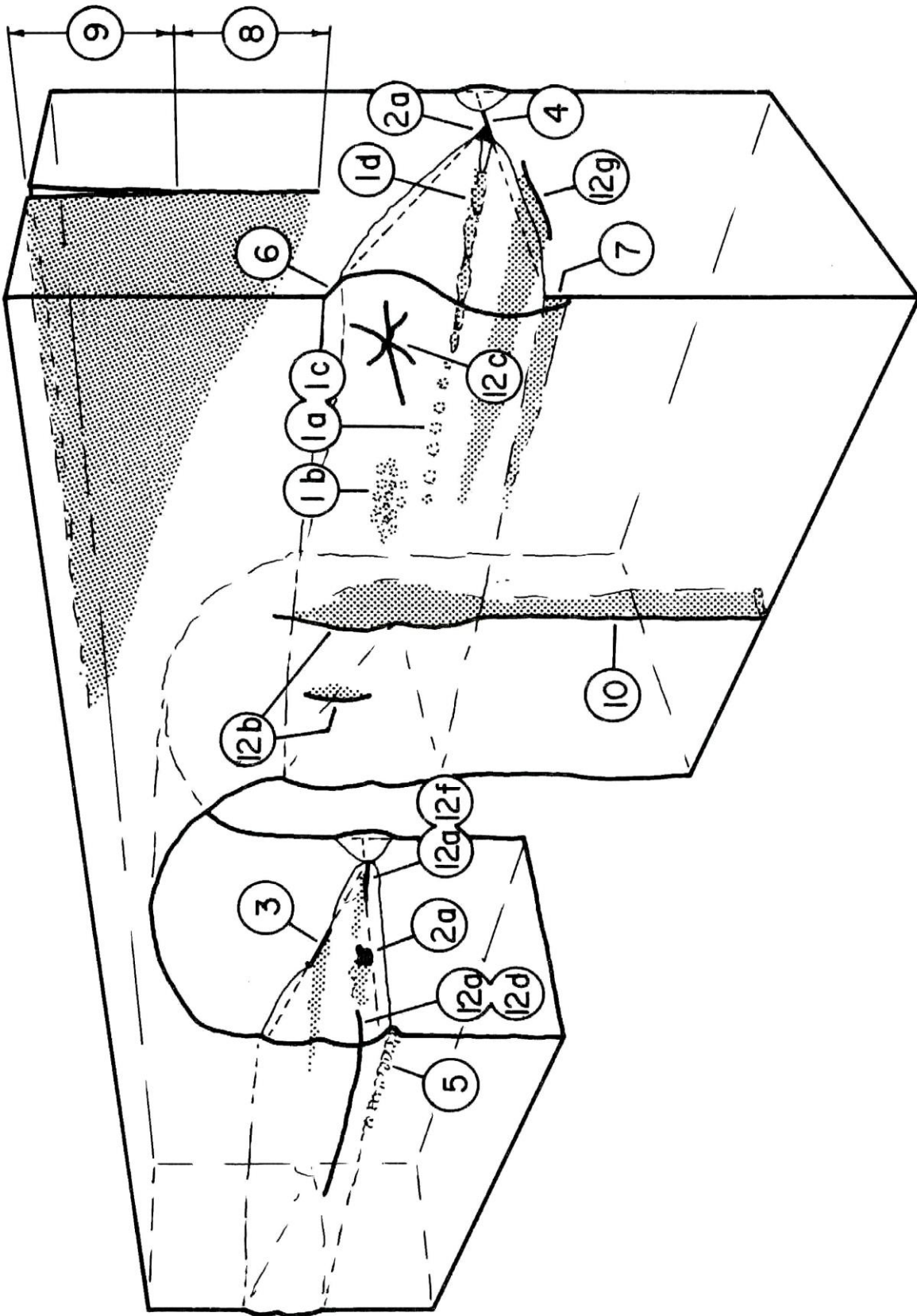

FIGURE E 6 - SINGLE VEE GROOVE WELD IN BUTT JOINT

Notes:

APPENDIX F SUGGESTED FORMS

OFFICE OF STRUCTURES METALS ENGINEERING ROUTING TRANSMITTAL For Items Requiring Drawing Approval According to the Steel Construction Manual				
From: _____				
Address: _____				
City, State, Zip: _____				
Date: _____				
To: New York State Dept. of Transportation		Contract (D)# _____	PIN: _____	
Office of Structures		Job Description: _____		
50 Wolf Rd. POD 4-3		County: _____		
Albany, NY				
Attn: Paul Rimmer – Metals Engineering				
We are sending you the following shop drawings for Item No.: _____				
_____ Preliminary Review & Approval				
_____ Hard Copy Submission: Two (2) copies				
_____ Electronic Submission: Files submitted by electronic transfer				
_____ Signature Review & Approval				
_____ Hard Copy Submission: One (1) copy				
_____ Electronic Submission: Files submitted by electronic transfer				
_____ Distribution of Signature Approved Shop Drawings				
_____ Hard Copy Submission: One paper print of Signature Approved Shop Drawings				
_____ Electronic Submission: One paper print of Signature Approved Shop Drawings				
_____ Microfilm Aperture Card Submission (Triplicate)				
SHOP ORDER #	DWG#	DESCRIPTION	REVISION #	
Remarks: Contact person and phone no. _____				
Routing Sequence	Date Rec.	Date Ret.	Approval or Action	Approver Name
1) Fabricator				
2) M.O. Struct.				
cc: Regional Construction Engineer EIC Contractor				

Figure F-1 Routing Transmittal

TO:		DATE submitted:	CONTRACTOR	DETAILER
------------	--	------------------------	-------------------	-----------------

			RFI NO.	RFI NO.
ATTN:		D# NUMBER	PROJECT NAME:	COUNTY
	CONTRACTOR:	PIN #	BIN #	
	FABRICATOR:	Structure Name, Span or Group of Spans		
	Contractor Address:	SUBJECT:		
	Phone No. Fax No.			
	Fabricator Address:	REQUEST FOR INFORMATION		
	Phone No. Fax No.			
QUESTION:				
POTENTIAL RESOLUTION PROPOSED:				
COPY				
RESPONSE			DATE:	
Respondent's Name				
Phone			E-mail	
COPIES TO:				

Total Pages:

Figure F-2 Request for Information

GIRDER HEAT NUMBER RECORD

CONTRACT:	PROJECT ID. NO.:
STRUCTURE:	COUNTY:
FAB. SHOP:	SHOP ORDER NO:
REPORTED BY:	SHOP DWG. NO:

Piece Mark	Top Flange	Web	Bottom Flange

Remarks:

Figure F-6 Girder Heat Number Record

STRINGER STATUS RECORD

CONTRACT:	PROJECT ID. NO.:
STRUCTURE:	COUNTY:
FAB. SHOP:	SHOP ORDER NO:
REPORTED BY:	SHOP DWG. NO:

Piece Mark									
Approved Drawing									
Welders Qualifications									
Approved Weld Procedure									
Mill Certs									
	Init.	Date	Init.	Date	Init.	Date	Init.	Date	Init.
Heat Camber									
Cover Plate Fit T/B									
Cover Plate Welded T/B									
Weld Dimensions Checked									
NDT	Radiography								
	Mag. Particle								
	Ultrasonic								
	Length Check								
	Web Flatness								
Flange Tilt									
Camber Check									
Sweep Check									
Blast Clean									
Pick Up Repairs									
Paint	1 st Coat								
	2 nd Coat								
	3 rd Coat								
Final Approval									
Shipment									
Weight (lb.)									

Figure F-7 Stringer Status Record

GIRDER STATUS RECORD

CONTRACT:	PROJECT ID. NO.:
STRUCTURE:	COUNTY:
FAB. SHOP:	SHOP ORDER NO:
REPORTED BY:	SHOP DWG. NO:

Piece Mark										
Approved Drawing										
Welders Qualifications										
Approved Weld Procedure										
Mill Certs										
	Init.	Date	Init.	Date	Init.	Date	Init.	Date	Init.	Date
Top Flange Cut										
Top Flange Welded										
Top Flange RT										
Bottom Flange Cut										
Bottom Flange Welded										
Bottom Flange RT										
Web Cut										
Web Welded										
Web RT										
Web to Flange Fit										
Web to Flange Welded										
Stiffeners Fit										
Stiffeners Welded										
Fit Others										
Weld Others										
Weld Dimension Checked										
Bearing Area Flatness										
NDT	Mag. Particle									
	Ultrasonic									
Length Check										
Web Flatness										
Flange Tilt										
Camber Check										
Sweep Check										
Blast Clean										
Pick Up Repairs										
Paint	1 st Coat									
	2 nd Coat									
	3 rd Coat									
Final Approval										
Shipment										
Weight (lb.)										

Figure F-8 Girder Status Record

CAMBER REPORT

CONTRACT:	PROJECT ID. NO.:
STRUCTURE:	COUNTY:
FAB. SHOP:	SHOP ORDER NO:
REPORTED BY:	SHOP DWG. NO:

MEASUREMENT LOCATION AND IDENTIFICATION SKETCH:

Camber										
Req.										
Act.										
+ or -										

Camber										
Req.										
Act.										
+ or -										

Camber										
Req.										
Act.										
+ or -										

Camber										
Req.										
Act.										
+ or -										

Figure F-9 Camber Report

SWEEP REPORT

CONTRACT:	PROJECT ID. NO.:
STRUCTURE:	COUNTY:
FAB. SHOP:	SHOP ORDER NO:
REPORTED BY:	SHOP DWG. NO:

Top Flange

Distance From Left	Required Sweep	Sweep Before Heat Correction	Final Sweep	Heat Location (from left)

Bottom Flange

Distance From Left	Required Sweep	Sweep Before Heat Correction	Final Sweep	Heat Location (from left)

Figure F-10 Sweep Report

NDT INSPECTION RECORD

CONTRACT:			PROJECT ID. NO.:			
STRUCTURE:			COUNTY:			
FAB. SHOP:			SHOP ORDER NO:			
REPORTED BY:			SHOP DWG. NO:			
Date	Piece Mark	NDT Type	OBSERVATIONS	Accepted	ASNT Operators	Witnessed By

Figure F-11 NDT Inspection Record

SIGN STRUCTURE AND POLE STATUS RECORD

CONTRACT:	PROJECT ID. NO.:
STRUCTURE:	COUNTY:
FAB. SHOP:	SHOP ORDER NO:
REPORTED BY:	SHOP DWG. NO:

Item Type Piece Mark Approved Dwg.										
	Init.	Date	Init.	Date	Init.	Date	Init.	Date	Init.	Date
Welders Qualifications										
Approved WPS										
Mill Certs										
Cutting										
Drilling										
Welding Complete										
Weld Dimensions Checked										
NDT	Dye Penetrant									
	Magnetic Particle									
	Radiographic									
Ultrasonic										
Galvanizing										
Storage										
Final Approval										
Shipping										
Weight (lb.)										

Remarks:

Figure F-13 Sign Structure and Pole Status Record

SECONDARY AND MISCELLANEOUS ITEMS STATUS RECORD

CONTRACT:	PROJECT ID. NO.:
STRUCTURE:	COUNTY:
FAB. SHOP:	SHOP ORDER NO:
REPORTED BY:	SHOP DWG. NO:

Item								
Type								
Piece Mark								
Quantity								
Approved Drawing								
	Init.	Date	Init.	Date	Init.	Date	Init.	Date
Mill Certs								
Material Cut								
Holes Drilled								
Assembly/Weld Complete								
Blast Clean								
Paint/Galvanizing Complete								
Final Check								
Shipping								
Weight (lb.)								

Remarks:

Figure F-14 Secondary and Miscellaneous Status Record

EXPANSION JOINT STATUS RECORD

CONTRACT:	PROJECT ID. NO.:
STRUCTURE:	COUNTY:
FAB. SHOP:	SHOP ORDER NO:
REPORTED BY:	SHOP DWG. NO:

	Type										
	Piece Mark	Init.	Date	Init.	Date	Init.	Date	Init.	Date	Init.	Date
	Approved Dwgs.										
	Welders Quals.										
	Approved WPS.										
	Mill Certs										
Cutting	Angles										
	Divisor										
	Pedestals										
	Curb Parapet										
	Welding Complete										
	Stud Welding Complete										
	Bend Test										
Dimension Check	Length										
	Elevation										
	Lug Depth										
	Pedestals										
	Contours										
Seal	Certs										
	(Car Seal #)										
	Sample										
	Approved										
	Blast Clean										
	Installation of Seal										
	Depth of Seal										
	Joint Opening										
	Cleaning of Seal										
	Final Approval										
	Shipping										
	Weight (lb.)										

Figure F-15 Expansion Joint Status Record

Notes:

APPENDIX G
ITEMS REQUIRING ARCHIVING:

	Approving Authority
Exodermic Bridge Deck:	
Exodermic Bridge Deck Using Lightweight HPS Concrete, Item xx557.40	D.C.E.S
Exodermic Bridge Sidewalk With Class DP Concrete, Item xx557.41	D.C.E.S
Precast Exodermic Bridge Deck Panels, Item xx557.42	D.C.E.S
Inverset:	
Precast Precompressed Concrete/Steel Composite Superstructure, Item 563.88	D.C.E.S
Structural Steel:	
Bridge Hanger Assemblies, Item xx564.02	D.C.E.S
Structural Steel Type (1-16), Item 564.05XX	D.C.E.S
Structural Steel Replacement, Item 564.10	E.I.C.
Cable Restrainer Assembly, Item xx564.22	D.C.E.S
High Performance Steel, Item xx564.40 & xx564.41	D.C.E.S
End Bolting Partial Length Cover Plates, Item xx564.47nn	D.C.E.S
Structural Steel, Item 564.51	D.C.E.S
Structural Steel Replacement, Item 564.70	E.I.C.
Prefabricated Pedestrian Superstructures:	
Prefabricated Pedestrian Superstructures, Item xx564.80nn	D.C.E.S
Steel Frame Pedestrian Superstructure, Item xx564.0501	D.C.E.S
Bearings:	
Steel Rocker Bearings, Items 565.1121 & 565.1221	D.C.E.S
Steel Sliding Bearings, Items 565.1321 & 565.1421	D.C.E.S
Multi-rotational Bearings, Items 565.152n & 565.172n	E.I.C.
Base Isolation Bearing Systems, Item 16565.64	E.I.C.
Joints:	
Modular Expansion Joint Systems, Item 566.nn	D.C.E.S
Armored Joint Systems with Compression Seal, Item 567.nn	E.I.C.
Grating:	
Open Steel Floor, Item 596.01	D.C.E.S
Sign Structures:	
Single Arm Cantilever Sign Structure, Item 644.41xxyy	D.C.E.S
Trussed Arm Cantilever Sign Structure, Item 644.42xxyy	D.C.E.S
Single Span Sign Structure, Item 644.43xxyy	D.C.E.S
Non-Standard Sign Structure, Item 644.44nn	D.C.E.S
Miscellaneous Metals:	
Miscellaneous Metals, Item 656.01	D.C.E.S
Timber:	
Timber Bridge Railing, Item 597.10	D.C.E.S
Timber Pedestrian Bridge Superstructure, Item 08594.0701	D.C.E.S
Glulam Timber Bridge Deck, Item 04594.10	D.C.E.

**APPENDIX H
APERTURE CARDS**

VACANT

APPENDIX I ELECTRONIC SUBMISSIONS

The first sheet of all electronic submissions must include a comprehensive index of drawings.

PROJECTWISE FOLDER HIERARCHY

Region

 D Number

 Structures Construction

 Steel Fabricator #1

 BIN number & Shop Order number

 Metals Engineering Folder

 BIN number & Shop Order number

 Metals Engineering Folder

 Steel Fabricator #2

 BIN number & Shop Order number

 Metals Engineering Folder

 BIN number & Shop Order number

 Metals Engineering Folder

 Shop Inspection Folder

Preferred File Naming Nomenclature

Use single letter designations for Preliminary Approval (P), and Signature Approval (S), submissions.

(P) Gives Fabricator permission to fabricate.

(S) Gives Fabricator permission to ship the steel

(REV) Revision Number

 Use letter designation prior to signature approval.

 Use number designation after signature approval.

Examples for numbered drawings:

 For projects with less than 100 numbered drawings:

 P 01AB.tif

 P 01AB REVA.tif

 S 01AB.tif

 S 01AB REV1.tif

 For projects with over 100 numbered drawings

 P 001AB.tif

 P 001AB REVA.tif

 S 001AB.tif

 S 001AB REV1.tif

Example for lettered drawings:

 P E01AB.tif

 S E01AB.tif

Large Projects (IE: More than one shop order number per BIN)

 Structures Construction// High Steel Structures// BIN #// Various shop order numbers.

.....
Below find agreement with construction:

FILE AND DOCUMENT NAME FORMAT

In ProjectWise each file has a file name, a document name, and a description associated with it. File names and document names should be identical. The file/document name for each file associated with a contract shall begin with the contract D number or on a contract with multiple structures the BIN number of the structure which the file pertains to.

The following format shall be used:

D or BIN number_XXX_yyy_zzz_ddd_a##.ext

Files from Design will have the project PIN number in place of the contract D number

where:

'D' is the construction contract 'D' number which may be used once it has been assigned

'BIN' is the BIN number for the structure which file pertains to

'xxx' indicates the category name (see table below)

'yyy' indicates the document sub category name (if necessary)

'zzz' designates the document secondary sub category name (if necessary)

'ddd' is reserved for a descriptive name if needed (such as the subject of a letter, or dtm name)

'a##' is reserved for Revision Number, or Amendment Numbers (if necessary)

'ext' is the file extension native to the software used to create the file.

APPENDIX J
FILE NAMING CONVENTION FOR STEEL SHOP DRAWING

Steel Shop Drawing designations shall follow the guidelines provided in Section 1.2 of the AASHTO/NSBA Steel Bridge Collaboration G 1.3-2002:

Type of Drawing:

Prefix	Content Description:
I	Index of drawings (required for all electronic submissions)
WS	Worksheets
GN	General shop notes and typical details
G	Girder diagrams
WC	Web camber details
FS	Flange splicing details
FW	Field work sheets (used to obtain field dimensions and/or show required fieldwork, including field reaming and drilling)
HC	Horizontal curve diagrams
SB	Sub-assemblies
SD	Sub-assemblies
E	Erection Framing Plans Note: these are not erection procedure plans.
SA	Shop assembly diagrams
ND	Numbered Drawings Details of girders, cross frames, stringers, diaphragms, etc.
X	Girder Job Standards
Z	Stringer Job Standards
M	Cross Frame Job Standards

FILE NAMING CONVENTION FOR ERECTION DRAWINGS

EP Erection Procedure

FILE NAMING CONVENTION FOR TRANSPORTATION DRAWINGS

SP Shipping procedures (detailed procedure to ship unique pieces)

Notes:

APPENDIX K

VACANT

Notes:

APPENDIX L
FHWA Appendix A1 – A325

Procedure for Performing Rotational Capacity Test

Long Bolts in Tension Calibrator

Equipment Required

1. Calibrated bolt tension measuring device of the size required for the bolts to be tested.
2. Calibrated torque wrench and spud wrenches.
3. Spacers with holes $\frac{1}{16}$ larger than bolt to be tested or nominal diameter washers.
4. Steel section to mount the tension calibrator.

Procedure:

A Rotational Capacity Test Consists of 2 Assemblies.

1. Measure the bolt length, the distance from the end of the bolt to the washer face at the bolt head to shank interface.
2. Install the bolt in the tension calibrator with the required spacers or washers so that the bolt stick-out is flush with the nut to a maximum of three threads. This will typically provide three to five threads within the grip, the distance between the bolt head and the inside face of the nut. This same stick-out requirement applies during installation.
3. Tighten the fastener assembly using a spud wrench to the tensions listed below -0 / +2 kips.

Bolt Dia. (in.)	1/2	5/8	3/4	7/8	1	1 1/8	1 1/4	1 3/8	1 1/2
Initial Tension (kips)	1	2	3	4	5	6	7	9	10

4. Match mark the bolt, nut and face plate of the calibrator.
5. Using the calibrated torque wrench, tighten the fastener assembly to at least the minimum installation tension listed below and record both the tension and torque. Torque shall be read with the nut rotating. The torque value from the test shall not exceed $T = .25 PD$. $P =$ tension in pounds. $D =$ Dia. (in.)/12 = bolt diameter in feet.

Bolt Dia. (in.)	1/2	5/8	3/4	7/8	1	1 1/8	1 1/4	1 3/8	1 1/2
Tension (kips)	12	19	28	39	51	56	71	85	103

6. Further tighten the bolt to the rotation listed below. The rotation is measured from the initial marking in step 4.

Bolt Length (from step 1)	4X bolt dia. Or less	Greater than 4 dia. But no more than 8 dia.	Greater than 8 bolt dia.
Required Rotation	2/3	1	1 1/6

- Record the tension at the completion of the rotation in Step 6. The tension shall equal or exceed 1.15 x the minimum installation tension. The minimum required values are listed in the table below.

Bolt Dia (in.)	1/2	5/8	3/4	7/8	1	1 1/8	1 1/4	1 3/8	1 1/2
Tension (kips)	14	22	32	45	59	64	82	98	118

- Loosen and remove the nut. There shall be no signs of thread shear failure, stripping or torsional failure. The nut shall turn, with your fingers, on the bolt threads to the position it was in during the test. The nut does not need to run the full length of the threads. If you cannot turn the nut with your fingers it is considered thread failure.

Failure:

The following constitute a failure of the rotational capacity test.

- Exceeding the maximum allowable torque in the torque/tension comparison.
- Failure to achieve the required rotation.
- Failure to achieve the required tension at the required rotation.
- Thread failure.

Failure of any one of these items on either assembly constitutes a failure of the rotational capacity test. When a failure occurs, the subject lot of fasteners is rejected. The contractor is given the option to clean and re-lubricate as necessary and then retest the fastener assemblies.

APPENDIX M

METRIC TABLES

M1 METRIC/ ENGLISH BOLT SUBSTITUTION TABLE

EQUIVALENT BOLT SIZES		HOLE DIAM (MM)	METRIC – ASTM GRADE SPECIFIED					
			F - 568 CLASS 8.8	F-588 CLASS 8.8.3	F - 568 CLASS 9.8	F - 568 CLASS 10.9	A - 325M TYPE 1 OR 2	A - 325M TYPE 3
METRIC (MM)	ENGLISH (INCHES)		ENGLISH BOLT SUBSTITUTION - ASTM GRADE					
M16	5/8	18			N O T			
M20	3/4	22			R	A - 354 GRADE BD	A - 325 TYPE 1 OR 3	
M22	7/8	24	A 325 TYPE 1 OR 3		E			A - 325 TYPE 3
M24	1	27		A - 325 TYPE 3	Q	OR		
M27	1 1/8	30	A 449 TYPE 1		U	A - 490 TYPES 1 OR 3	OR	
M30	1 1/4	34			I		A - 449 TYPE 1	
M36	1 1/2	40			R E D			

* ZINC COATED AS PER ASTM A153

** PLAIN OR ZINC COATED

WASHERS SHALL BE F-436 WITH SAME FINISH (PLAIN OR ZINC COATED) AS THE BOLT.

Unless otherwise shown in the contract documents, appropriate English (inch) bolt and nut substitutions will be allowed in accordance with these tables.

ENGLISH BOLT	APPROPRIATE NUTS
A-325 TYPE 1	A 563 - C,C3, D, DH*, DH3 A 194-2,2H*
A-325 TYPE 3	A 563-C, DH3
A-449 TYPE 1 DIAM < 1.5"	A 563 GRADE DH* HEAVY HEX A 563 GRADE DH** HEAVY HEX
A-354 GRADE BD	A 563 GRADE DH or DH3 or A194 GRADE 2H
A-490 TYPE 1	

No substitution will be allowed for any A325M bolts supplied under §715-14 and used for structural connections on bridges, unless approved by the DCES.

**TABLE 505M - VISUAL INSPECTION AND REPAIR OF EDGES OF PLATES AND SHAPES
(100 mm AND UNDER IN THICKNESS)**

<i>Description of Discontinuity</i>	<i>Repair Required</i>
Any discontinuity 25 mm in length or less	None - need not be explored
Any discontinuity over 25 mm in length and 3 mm maximum depth	None - depth shall be explored by random spot grinding well faired in order not to create notches in the plate edge
Any discontinuity over 25 mm in length with depth over 3 mm but not greater than 6 mm	Remove by grinding or air carbon arc gouging followed by grinding. The excavation shall be well faired in order not to create notches in the plate edge If the removal of a discontinuity reduces the net cross section area of the plate by more than 5%, the resultant cavity shall be filled by welding** Aggregate length of welding shall not exceed 20% * of plate edge length being repaired
Any discontinuity over 25 mm in length with depth over 6 mm but not greater than 25 mm	Completely remove and weld. Aggregate length of welding shall not exceed 20%* of plate edge length being repaired **
Any discontinuity over 25 mm in length with depth greater than 25 mm	Subject to approval by the DCES. Gouge out to 25 mm and block off by welding. Aggregate length of welding shall not exceed 20% * of plate edge length being repaired.**
*Defects exceeding this length require the approval of the DCES before being repaired. **Repair welding of tension members will be subject to radiographic inspection.	

NOTES:

1. This specification applies only to edges which will not be joined by welds subject to calculated stress. This specification does not apply to any plate or shape that is subject to stress across its thickness (i.e., in "Z" direction).
2. Length of a defect is the visible long dimension on an edge. Depth is the distance that the defect extends into the plate or shape from the edge.
3. All manual welding shall be performed by qualified welders using low-hydrogen electrodes. Submerged Arc Welding and Flux Cored Arc Welding with external gas shielding may also be used with approved procedures. Cavities resulting from the removal of discontinuities shall be prepared prior to repair welding with a minimum radius of 6 mm and a minimum included angle of 20 degrees. When plate thickness is not sufficient for such preparation, repair welding will not be permitted.

TABLE 708M - MINIMUM PREHEAT AND INTERPASS TEMPERATURE

Thickness of Thickest Part at Point of Welding (mm)	ASTM A709-36, -50,-HPS70W, A36,A53,A252, A500 A501, A572, A992	ASTM A709-50W, A588, A847
To 19, inclusive	10°C	38°C
Over 19 to 38, inclusive	21°C	95°C
Over 38 to 64, inclusive	65°C	149°C
Over 64	107°C	176°C

TABLE 710aM – MINIMUM HOLDING TIME

6 mm or less	Over 6 mm through 50 mm	Over 50 mm
15 minutes	1 hour/ 25 mm	2 hours plus 15 minutes for each additional 25 mm over 50 mm

TABLE 710bM – ALTERNATIVE STRESS-RELIEF HEAT TREATMENT

Decrease in temperature below minimum Specified temperature (°C)	Minimum holding time at Decreased temperature, (hours per 25 mm of thickness)
10	2
38	3
65	5
93	10

TABLE 723M - WELD REINFORCEMENT

Plate Thickness (mm)	Thickness of Reinforcement (inches)
To 19, inclusive	none, grind flush
Over 19 to 25, inclusive	1 each side or 2 total
Over 25 to 50, inclusive	2 each side or 3 total
Over 50 to 75, inclusive	2 each side or 5 total
Over 75	3 each side or 6 total

**TABLE 742M - MINIMUM PREHEAT
AND INTERPASS TEMPERATURES**

Carbon equivalent range, %	Size of reinforcing bar	Degrees C
0.40 max.	Up to 11 inclusive 14 and 18	10 10
0.41 – 0.45 inclusive	Up to 11 inclusive 14 and 18	10 38
0.46 – 0.55 inclusive	Up to 6 inclusive 7 to 11 inclusive 14 and 18	10 10 95
0.56 – 0.65 inclusive	Up to 6 inclusive 7 to 11 inclusive 14 and 18	38 93 149
0.66 – 0.75	Up to 6 inclusive 7 to 18 inclusive	149 204
above 0.75	Up to 18 inclusive	260

Notes:

- 1) When reinforcing steel is to be welded to main structural material, the preheat requirements of the structural material shall also be considered (see Table 708). The minimum preheat requirement to apply in this situation shall be the higher requirement of the two tables.
- 2) Welding shall not be done when the ambient temperature is lower than 0° F. When the base metal is below the temperature listed for the welding process being used and the size and carbon equivalent range of the bar being welded, it shall be preheated in such a manner that the cross section of the bar for not less than 6 in. on each side of the joint shall be at or above the specified minimum temperature. Preheat and interpass temperatures must be sufficient to prevent crack formation.
- 3) After welding is complete, bars shall be allowed to cool naturally to ambient temperature. Accelerated cooling is prohibited.
- 4) Where it is impractical to obtain chemical analysis, the carbon equivalent shall be assumed to be above 0.75.

**TABLE 904M - FCM TOUGHNESS REQUIREMENT
FOR BASE METAL**

ASTM Designation A709	Thickness	<i>Average Minimum Toughness and Test Temperature^a</i>
36	up to 100 mm	34 Nm at 4°C
50 ^b and 50W ^b	up to 50 mm	35 Nm at 4°C
	over 50 mm to 100 mm	41 Nm at 4°C
HPS50W ^c	up to 100 mm	41 Nm at -12°C
HPS70W ^c	up to 100 mm	47 Nm at -23°C
<p>a) Minimum service temperature from -18°C to -34°C</p> <p>b) If the yield strength of the steel exceeds 448 MPa, the temperature for the CVN test for acceptability shall be reduced by -9°C for each increment of 69 MPa above 448 MPa. The yield strength is the value given in the certified mill test report.</p> <p>c) If the yield strength of the steel exceeds 586 MPa, the temperature for the CVN test for acceptability shall be reduced by -9°C for each increment of 69 MPa over 448 MPa. The yield strength is the value given on the certified mill test report (MTR).</p>		

**TABLE 906.2M - MINIMUM PREHEAT AND
INTERPASS TEMPERATURE FOR
WELDING FRACTURE CRITICAL MEMBERS - (DEGREES C)**

Thickness of Thickest Part at Point of Welding(mm)	ASTM A709- 36 & 50	ASTM A709- 50W & 70W
To 19, inclusive	38	38
Over 19 to 38	65	93
Over 38 to 64	93	149
Over 64	149	176

**TABLE 910M - PENETRATOR REQUIREMENTS
FOR FRACTURE CRITICAL MEMBERS***

Nominal material Thickness range (mm)	Penetrator Identification	Penetrator Thickness (mm)	Essential hole
Up to 10	7	.180	4T
Over 10 to 13	10	.250	4T
Over 13 to 16	12	.305	4T
Over 16 to 19	15	.380	4T
Over 19 to 22	17	.430	2T
Over 22 to 25	20	.510	2T
Over 25 to 32	25	.635	2T
Over 32 to 38	30	.760	2T
Over 38 to 50	35	.890	2T
Over 50 to 64	40	1.00	2T
Over 64 to 75	45	1.140	2T
Over 75 to 100	50	1.270	2T
Over 100 to 150	60	1.520	2T
*Fracture Critical Member or Component			

TABLE 1001.5aM - BOLT TENSION

Bolt Diameter (mm)	Minimum Bolt Tension ^a in Thousands of Pounds (kN) A325 Bolts
13	53
16	85
19	125
22	173
25	227
29	249
32	316
35	378
38	458
^a Equal to 70 percent of specified minimum tensile strengths of bolts, rounded off to the nearest kip.	

TABLE 1211.1M - MAXIMUM DEVIATION FROM WEB FLATNESS FOR GIRDERS WITH INTERMEDIATE STIFFENERS AND/OR CONNECTION PLATES

Least Panel Dimension (mm)	305	457	635	787	940	1,118	1,270	1,422	1,575	1,753	1,905	2,057	2,210	2,388	2,540
Allowable Deviation (mm)	3	5	6	8	10	11	13	14	16	17	19	21	22	24	25

TABLE 1211.2M - MAXIMUM DEVIATION FROM WEB FLATNESS FOR GIRDERS WITHOUT INTERMEDIATE STIFFENERS, CONNECTION PLATES OR OTHER FULL DEPTH ATTACHMENTS THAT MAY STIFFEN THE WEB.

Depth of Web (mm)	483	711	940	1,194	1,422	1,676	1,905	2,134	2,388	2,616	2,870	3,099	3,327	3,581	3,810
Allowable Deviation (mm)	3	5	6	8	10	11	13	14	16	17	19	21	22	24	25

TABLE 1604.1M- PENETRAMEETER REQUIREMENTS

Nominal material Thickness range (mm)	Penetrameter Identification	Penetrameter Thickness	Essential Hole
Up to 10	12	.305	4T
Over 10 to 16	15	.380	4T
Over 16 to 19	17	.430	4T
Over 19 to 25	20	.510	4T
Over 25 to 32	25	.635	4T
Over 32 to 38	30	.760	2T
Over 38 to 50	35	.890	2T
Over 50 to 64	40	1.00	2T
Over 64 to 75	45	1.140	2T
Over 75 to 100	50	1.270	2T
Over 100 to 150	60	1.520	2T

TABLE 1700A M PROCEDURE CHART

PROCEDURE CHART													
Weld Type	Weld or Material Thickness												
	5/16 to 1/2	>1/2 to 1	>1 to 1 1/2	>1 1/2 to 1 3/4	>1 3/4 to 2 1/2	>2 1/2 to 3 1/2	>3 1/2 to 4 1/2	>4 1/2 to 5	>5 to 6 1/2	>6 1/2 to 7	>7 to 8		
	*	*	*	*	*	*	*	*	*	*	*	*	*
Butt	1a 0	1b 0	1c F	2 F	2** or 3 F	2** or 3** F	4 F	5** or 4** F	6** or 5** F	6** or 7 F	9** F		
Tee	1d or 1e 0	1d or 1e 0	1c F or XF	2 F or XF	2** F or XF	2** F or XF	4 F or XF	5** F or XF	6** F or XF	6** F or XF	7** F or XF	-	-
Corner	1d or 1e 0	1d or 1e 0	1c F or XF	2 F or XF	2** F or XF	2** F or XF	4 F or XF	5** F or XF	6** F or XF	6** F or XF	7** F or XF	-	-
Electrogas & Electroslag	1a and RT 0	1b and RT 0	1c and RT 0	2 and RT 0	2** or 3 and RT 0	2** or 3** and RT 0	8** and RT 0	8** and RT 0	8** and RT 0	9** and RT 0	9** and RT 0		

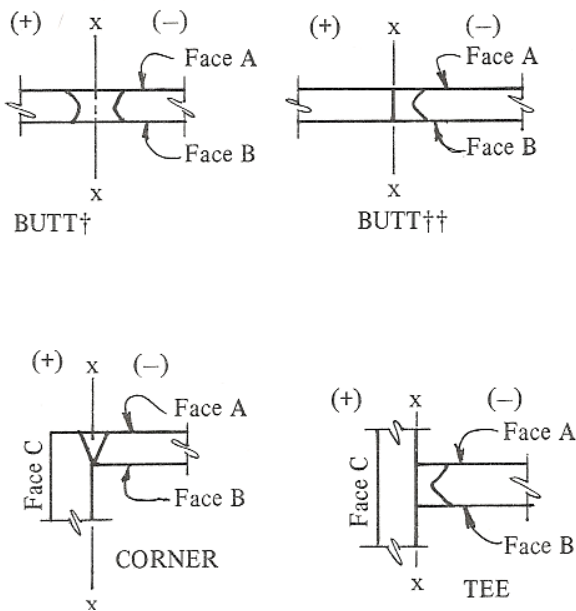

PROCEDURE LEGEND			
NO.	Area of Weld Thickness		
	TOP QUARTER	MIDDLE HALF	BOTTOM QUARTER
1a	70° I and II	70° I and II	70° I and II
1b	70° I and II	70° I and II	70°
1c	70° I and II	70°	70°
1d	70° I and II AB	70° I and II AB	70° I and II AB
1e	70° I, II and III	70° I, II and III	70° I, II and III
2	70° + 60° II	70°	70°
3	70° + 45° II	70°	70°
4	60° B	70°	60°
5	60° B	60°	60°
6	45° B	70°	45°
7	45° B	45°	45°
8	70° B	70° A B	70° A
9	70° GA+60° B	70° A B	60° A+70° GB

**TABLE 1700B M – HIGHWAY & RAILWAY BRIDGES (TENSION)
Ultrasonic Acceptance-Rejection Criteria**

Flaw severity class	Weld thickness and search unit angle										
	5/16 to 3/4	> 3/4 to 1 1/2	> 1 1/2 to 2 1/2			> 2 1/2 to 4			> 4 to 8		
	70°	70°	70°	60° *	45° *	70°	60° *	45° *	70°	60° *	45° *
Class A	+10 & lower	+8 & lower	+5 & lower	+8 & lower	+10 & lower	+3 & lower	+6 & lower	+8 & lower	as determined by the DCES		
Class B	+11	+9	+6 +7	+9 +10	+11 +12	+4 +5	+7 +8	+9 +10	as determined by the DCES		
Class C	+12	+10	+8 +9	+11 +12	+13 +14	+6 +7 +8 +9	+9 +10 +11 +12	+11 +12 +13 +14	as determined by the DCES		
Class D	+13 & up	+11 & up	+10 & up	+13 & up	+15 & up	+10 & up	+13 & up	+15 & up	as determined by the DCES		

NOTES:

1. Class Band C flaws shall be separated by at least 2L, L being the length of the longer flaw, except that when two or more such flaws are not separated by at least 2L, but the combined length of flaws and their separation distance is equal to or less than the maximum allowable length under the provisions of Class B or C, the flaw shall be considered a single acceptable flaw.
2. Class Band C flaws shall not begin at a distance less than 2L from the end of the weld or from any intersection weld, L being the flaw length.
3. Flaws detected at "scanning level" in the root face area of complete penetration double vee, double "J", double "O", and double bevel groove weld joints shall be evaluated using an indication rating 4 db more sensitive than that described in this table, i.e., add +4 db to the values in this table.

Class A (large flaws)

Any indication in this category shall be rejected (regardless of length).

Class B (medium flaws)

Any indication in this category having a length greater than 3/4 shall be rejected.

Class C (small flaws)

Any indication in this category having a length greater than 2 inches in the middle half or 3/4 inch length in the top or bottom quarter of weld thickness shall be rejected.

Class D (minor flaws)

Any indication in this category shall be accepted regardless of length or location in the weld.

Scanning levels

Sound path, mm**	Above zero reference, db
To 64	+20
> 64 to 125	+25
> 125 to 250	+35
> 250 to 380	+45
> 380 to 510	+55

** This column refers to sound path distance and not material thickness.

*Flaws evaluated with 60° or 45° search units and rejected at the acceptance levels listed in the table, but which are acceptable at the minimum acceptance level listed for a 70° transducer shall also be evaluated with a 70°, 70°, & 45° or 70° & 60° search units, as necessary to evaluate the flaw with all three angles transducers. If this detailed testing reveals that the sound beam of the 60° or 45° search unit is striking the flaw at 90°±15° the acceptance level listed for a 70° transducer shall be used as the basis for acceptance, regardless of the angle of the search unit used to evaluate the flaw.

**TABLE 1700C M – BUILDINGS (COMPRESSION)
Ultrasonic Acceptance-Rejection Criteria**

Flaw severity class	Weld thickness and search unit angle										
	5/16 to 3/4	>3/4 to 1 1/2	>1 1/2 to 2 1/2			>2 1/2 to 4			>4 to 8		
	70°	70°	70°	60°*	45°*	70°	60°*	45°*	70°	60°*	45°*
Class A	+5 & lower	+2 & lower	-1 & lower	+2 & lower	+4 & lower	-3 & lower	0 & lower	+2 & lower	as determined by the DCES		
Class B	+6	+3	0 +1	+3 +4	+5 +6	-2 -1	+1 +2	+3 +4	as determined by the DCES		
Class C	+7	+4	+2 +3	+5 +6	+7 +8	0 +1	+3 +4	+5 +6	as determined by the DCES		
Class D	+8 & up	+5 & up	+4 & up	+7 & up	+9 & up	+2 & up	+5 & up	+7 & up	as determined by the DCES		

NOTES:

1. Class B and C flaws shall be separated by at least 2L, L being the length of the longer flaw, except that when two or more such flaws are not separated by at least 2L, but the combined length of flaws and their separation distance is equal to or less than the maximum allowable length under the provisions of Class B or C, the flaw shall be considered a single acceptable flaw.
2. Class Band C flaws shall not begin at a distance less than 2L from weld ends carrying primary tensile stress, L being the flaw length.
3. Flaws detected at "scanning level" in the root face area of complete penetration double vee, double "J", double "U", and double bevel groove weld joints shall be evaluated using an indication rating 4 db more sensitive than that described in this table, i.e., add + 4 db to the values in this table.
4. Electroslag or electrogas welds - Flaws detected at "scanning level" which exceed 2 inches in length shall be suspected as being piping porosity and shall be further evaluated with radiography.

Class A (large flaws)

Any indication in this category shall be rejected (regardless of length).

Class B (medium flaws)

Any indication in this category having a length greater than ¾ inch shall be rejected.

Class C (small flaws)

Any indication in this category having a length greater than 2 inches in the middle half or ¾ inch length in the top or bottom quarter of weld thickness shall be rejected.

Class D (minor flaws)

Any indication in this category shall be accepted regardless of length or location in the weld.

Scanning levels

Sound path, mm**	Above zero reference, db
To 64	+14
> 64 to 125	+19
> 125 to 250	+29
> 250 to 380	+39
> 380 to 510	+49

** This column refers to sound path distance and not material thickness.

*Flaws evaluated with 60° or 45° search units and rejected at the acceptance levels listed in the table, but which are acceptable at the minimum acceptance level listed for a 70° transducer shall also be evaluated with a 70°, 70° & 45° or 70° & 60° search units, as necessary to evaluate the flaw with all three angles transducers. If this detailed testing reveals that the sound beam of the 60° or 45° search unit is striking the flaw at 90° ± 15° the acceptance level listed for a 70° transducer shall be used as the basis for acceptance, regardless of the angle of the search unit used to evaluate the flaw.

Notes:

APPENDIX N

VACANT

Notes:

APPENDIX O

VACANT

Notes:

APPENDIX P
NYSDOT ULTRASONIC TESTING TECHNICIAN PROGRAM

P1 GENERAL.

The NYSDOT Ultrasonic Testing Technician Program is administered by the Metals Engineering Unit of the Office of Structures, Albany, NY. Personnel performing ultrasonic testing on NYS DOT structures shall be certified under this program. A listing of NYS DOT Certified Ultrasonic Testing Technicians is available on the NYS DOT web page.

P2 TESTING PROGRAM.

P2.1 Test format.

- Part I – Closed book written, tests general UT theory and SCM Section 17.
- Part II – Open book written, tests ability to interpret provisions of SCM Section 17.
- Part III – Practical exam, tests ability to operate UT equipment and to evaluate a test weld.

P2.2 Grading.

Parts I and II are worth 25% each, Part III is worth 50%. A minimum grade of 70% is required to proceed to the next part of the exam. An overall grade of 80% is required to become certified.

P2.3 Retesting.

A candidate may retake the certification test 30 days after a first failure. If there is a second failure, the candidate must wait 1 year and provide documentation of additional ultrasonic testing training prior to scheduling an exam.

P2.4 Scheduling a Test.

Candidates interested in obtaining an Ultrasonic Testing Technician certification from NYSDOT should contact: The Metals Engineering Unit
Att: UT Program
50 Wolf Road, POD 4-3
Albany, NY 12322
Telephone: (518) 457-2436

P3 CERTIFICATION.

Certification is valid for 5 years provided the technician maintains a work record that indicates a minimum of twelve days of service each year.

P4 RECERTIFICATION.

Recertification at five years is awarded when an adequate work record is maintained or by reexamination. A 30 day grace period is allowed between the expiration date and recertification.

P5 DECERTIFICATION.

The NYS DOT certification is not valid if the minimum work record service is not attained. The DCES may revoke a certification at any time if it is determined that the Certified Ultrasonic Testing Technician is not performing to a level established by this program.

Notes: