

# Sustainable Development Framework

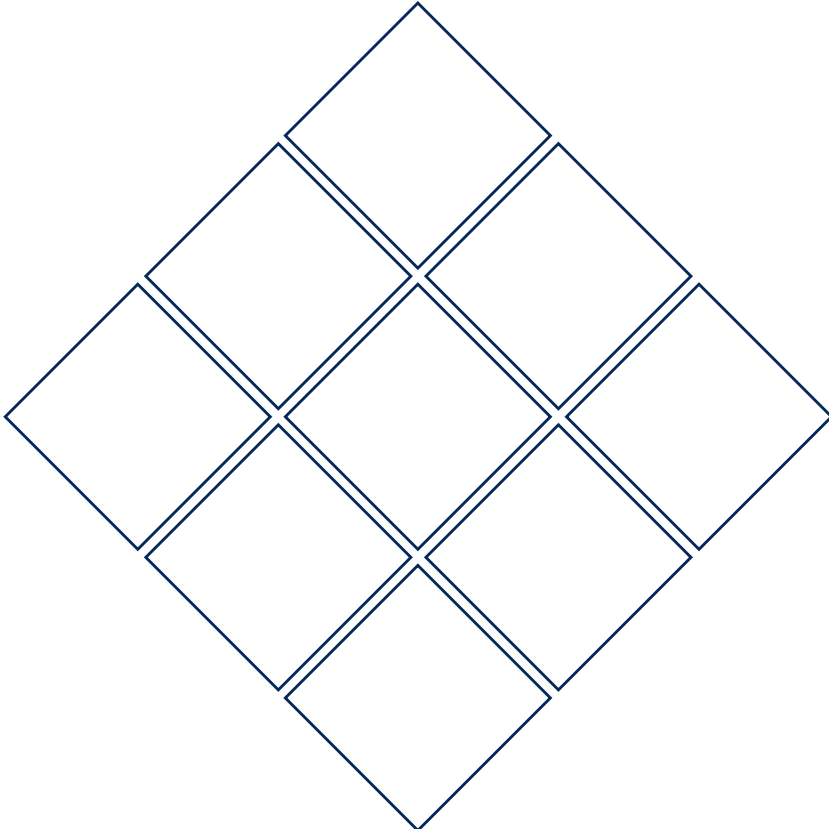

# Sustainable Development Framework

We care about building a better London – and that’s why sustainability is embedded into everything we do.

That means:

.....

Promoting Vibrant and Diverse Communities

.....

Creating Healthy Places for People and Planet

.....

Supporting and Developing Local Economies

.....

## Foreword

Transport for London (TfL) has a legacy of city building. For more than 150 years, London's transport network has shaped how the city has grown and evolved, becoming an iconic part of the capital's identity. Meanwhile TfL and its predecessors have enabled the sensitive transformation of historic neighbourhoods and the creation of entirely new communities.

In 2016 an exciting new chapter of the story was opened when we embarked on a bold programme of transformation for our vacant and underused spaces across the city. To lead this once-in-a-generation opportunity, TfL Property Development was established. Its mission is to champion good design, making London's neighbourhoods healthier and greener, more liveable and prosperous, more resilient and better connected – in other words, more sustainable.

Every development leaves a lasting impression, be it small infill sites or regeneration masterplans. It is therefore essential that sustainability is at the heart of every project we do.

The TfL Sustainable Development Framework (SDF) is our approach to delivering social impact, driving economic development, and embodying environmental stewardship in all our projects.

It sits alongside our Design Principles, Community Engagement Handbook, Heritage Best Practice Note and our Design Review Protocol to help us reinforce the quality and excellence of our work.

By sharing what we have done and learnt so far, we hope to use our broad portfolio of projects to lead the sector in delivering sustainable development for all Londoners.

This SDF is based on nearly three years of developing, piloting and collaborating. Our next step is to engage with our partners and stakeholders to finalise the detailed guidance that will support the Framework. It tackles not just the climate emergency, but also balancing a host of wider environmental, social, and economic issues. We are keen to continue to work with our partners and stakeholders to keep improving it.

We hope that through this Framework we can help inspire change, inform new approaches across the sector, and ultimately contribute to a stronger and more resilient London.

Graeme Craig

Director of Commercial Development  
Transport for London  
2021

## Table of Contents

Foreword	p. 4
Introduction	p. 6
Our Approach to Sustainability	p. 7
Building a Better London	p. 8
Supporting TfL Programmes	p. 9
The London Recovery Programme	p. 10
Structure of the Framework	p. 11
<b>Part 1</b>	
The Sustainable Development Framework (SDF)	p. 12
Developing the SDF	p. 13
How to Use the SDF	p. 14
An Introduction to the Indicators	p. 15
The Nine Dimensions	p. 16
1 Vibrant Places [VP]	p. 19
2 Social Cohesion [SC]	p. 21
3 Liveable Communities [LC]	p. 23
4 Health and Wellbeing [HW]	p. 26
5 Climate and Ecological Resilience [CR]	p. 29
6 High Performance Buildings [HPB]	p. 32
7 Financial Sustainability [FS]	p. 38
8 Local Prosperity [LP]	p. 40
9 Neighbourhood Investment [NI]	p. 43
<b>Part 2</b>	
The Sustainable Development Framework in Action	p. 45
How the Indicators Work	p. 47
Applying the Indicators	p. 48
<b>Summary</b>	
Conclusion	p. 58
Next Steps	p. 59
Endorsements and Credits	p. 60

# Introduction

## Our Approach to Sustainability

Five overarching principles guide our mission to build a more sustainable London:

- 1 Build a Better London: As the stewards of London's property estate, everything we do must embody the vision for London set out by the Mayor, TfL, and the London Recovery Programme.
- 2 Deliver Real Results: Whether we lease, manage, or develop new assets we apply rigorous methods and commit to delivering measurable results. We endeavor to work collaboratively with our partners and supply chain to ensure our projects deliver sustainability on the ground.
- 3 Think Long Term: We respect our role as public stewards and act in the long-term interests of Londoners. This means ensuring our developments are designed and built to safeguard the capital's future as a sustainable, inclusive, and economically resilient city.
- 4 Take a Holistic View: While acknowledging the huge importance of carbon reduction, the Sustainable Development Framework goes further, exploring a much wider definition of sustainability. Our approach is about promoting vibrant and diverse communities, developing local economies, and creating healthy places that are good for people and the planet. By bringing together these interlinked aspects of the built environment together, we hope we can create a sustainable solution that is greater than the sum of its parts.
- 5 Respond to Local Context: Development has a significant impact on local communities. To ensure that impact is a positive one, it is important to consider local opportunities and challenges. We therefore assess the context of each site individually to address local needs and priorities.

These principles are the foundation on which the SDF was built.

## Building a Better London

Our approach to sustainability fits in the wider context of helping TfL build a better London.

Our mission at TfL Property Development, as part of Commercial Development, is to build a better London, and as part of Transport for London and the wider Greater London Authority (GLA), to deliver the Mayor's policies and priorities for the capital.

Our core mandate is set out in the Mayor's Transport Strategy, which identifies three key themes:

- Healthy streets and healthy people
- A good public transport experience
- New homes and jobs

These complement the overarching New London Plan (2021) and sit alongside the Mayor's London Environment Strategy, London Housing Strategy, and London Economic Development Strategy.



## Supporting TfL Programmes

In addition to delivering wider Mayoral ambitions, TfL Property Development also directly supports a number of important programmes across TfL:

- Sustainability Report: This document sets out TfL's approach to sustainability. Using the three pillars of Society, Economy and Environment, the report includes all the related outputs and benefits we deliver through our activities. Our SDF aligns with this sustainability approach to ensure we continue to build a better and more sustainable city for Londoners.
- Long term revenue: The move from a funding model that has proved vulnerable due to its dependence on fares, to one that is more sustainable, diverse and long-term. This includes the delivery of high-quality and sustainable property developments which help generate revenue for TfL.
- Transport Capital Programmes: The critical ongoing investment in our world-class transport system. From replacing Underground trains and electrifying the bus network, to improving active travel and ensuring step-free access. Our activities support these programmes by delivering on-site transport improvements and providing vital revenue.
- Corporate Environment Plan: Our programme directly contributes to TfL's ambitions for making London more environmentally sustainable. The strategy's key themes of addressing the climate emergency, improving air quality, enhancing green infrastructure, using sustainable resources, and embedding best environmental practices are reflected in our approach to property development and its wider impacts.

## The London Recovery Programme

The London Recovery Board was set up in 2020 to guide the capital as it emerges from the coronavirus pandemic. As a member TfL has a critical role to play in restoring confidence in the city, minimising the impact on London's communities, and building back the city's economy and society.

Meeting that challenge involves a series of missions:

- 1 A Green New Deal: Tackle the climate and ecological emergencies and improve air quality by doubling the size of London's green economy by 2030 to accelerate job creation for all.
- 2 A Robust Safety Net: By 2025, every Londoner is able to access the support they need to prevent financial hardship.
- 3 High Streets for All: Deliver enhanced public spaces and exciting new uses for underused high street buildings in every borough by 2025, working with London's diverse communities.
- 4 A New Deal for Young People: By 2024 all young people in need are entitled to a personal mentor and all young Londoners have access to quality local youth activities.
- 5 Helping Londoners into Good Work: Support Londoners into good jobs with a focus on sectors key to London's recovery.
- 6 Mental Health and Wellbeing: By 2025 London will have a quarter of a million wellbeing ambassadors, supporting Londoners where they live, work and play.
- 7 Digital Access for All: Every Londoner to have access to good connectivity, basic digital skills and the device or support they need to be online by 2025.
- 8 Healthy Food, Healthy Weight: By 2025 every Londoner lives in a healthy food neighbourhood.
- 9 Building Strong Communities: By 2025, all Londoners will have access to a community hub ensuring they can volunteer, get support and build strong community networks.

Our property developments are a part of this picture, and we hope they can positively shape the recovery of London's neighbourhoods by building on these missions.

## Structure of the Framework

Performance-focused and metric driven, the SDF covers all aspects of social impact, economic prosperity and environmental stewardship.

The Framework is designed to be applied to any form of development, from small sites to large regeneration master plans, from housing projects to mixed-use and commercial schemes.

The handbook is set out in two parts:

Part 1 introduces the SDF, giving an overview of its structure, content and purpose and outlining the nine Dimensions that make up the SDF (see right);

Part 2 offers a step-by-step demonstration of the SDF in action, showing where and how it can be applied throughout the RIBA Stages of Work.

We are also developing a series of supporting Technical Guidance documents that provide the technical detail needed to implement the SDF in practice. Whilst currently undergoing consultation, once complete these will be available to download directly from the [TfL website](#).



Part I

# The TfL Sustainable Development Framework (SDF)

## Developing the SDF

To begin to address our aspiration of becoming a leader in sustainable development we looked to established leaders in both the public and private sectors for inspiration.

We found that those who deliver excellence in sustainability consistently adopt a performance-focused approach. They show that by using quantitative targets and performance metrics, it is possible to create specific, measurable, comparable and relevant ways to assess sustainability that translate ambition into delivery.

We have fine-tuned this approach in two significant ways to respond to the specific challenge of developing our land.

First, we have expanded out from the focus on the performance of buildings, giving equal weight to environmental, social and economic impacts. By thinking about sustainability holistically, we have applied metrics that look at the wider picture and create a more balanced outcome.

Second, we needed a system that could accommodate the diversity of our different sites and allow us to respond to local context. Consequently, instead of a 'one-size-fits-all' approach, we have created a Framework that is flexible enough to align with the specific needs of a site.

To ensure the SDF lives up to its ambitions, we have carefully and iteratively tested and piloted the SDF on over 20 housing, commercial and regeneration projects.

We are also treating the SDF as a living document. We are continuing to test, balance and refine it on our projects, and alongside best practice research and industry standards.

Through collaboration we have developed the Framework described in this handbook. Our next step is to engage with our development partners, local authorities, industry experts and the GLA to refine our detailed Technical Guidance. The combination of the two elements will bring the SDF to life, making it an open source tool that can positively impact London's ability to build sustainably.

## How to Use the SDF

The Framework is structured around nine Dimensions of sustainability, grouped under the three core categories that directly represent our mission.

The category of 'promoting vibrant and diverse communities' is broken down into the Dimensions of 'vibrant places', 'social cohesion' and 'liveable communities'. Under the category of 'creating healthy places for people and planet' are the Dimensions of 'health and wellbeing', 'climate resilience' and 'high-performance buildings'. And finally 'supporting and developing local economies' covers 'financial sustainability', 'local prosperity' and 'neighbourhood investment'.

Each Dimension contains between 4 and 29 sustainability Indicators (97 in total) that measure a particular process or outcome. These are all related to the UN's Sustainable Development Goals.

Which Indicators are relevant at which stage will depend upon the project type and the stage it is at. We envisage that a standard project might refer to between 60 and 80 Indicators during its development.

### 3 Categories

#### 9 Dimensions

#### 97 Key Performance Indicators (KPIs)

#### Evaluation 'Good Practice'

#### Evaluation 'Leading Practice'

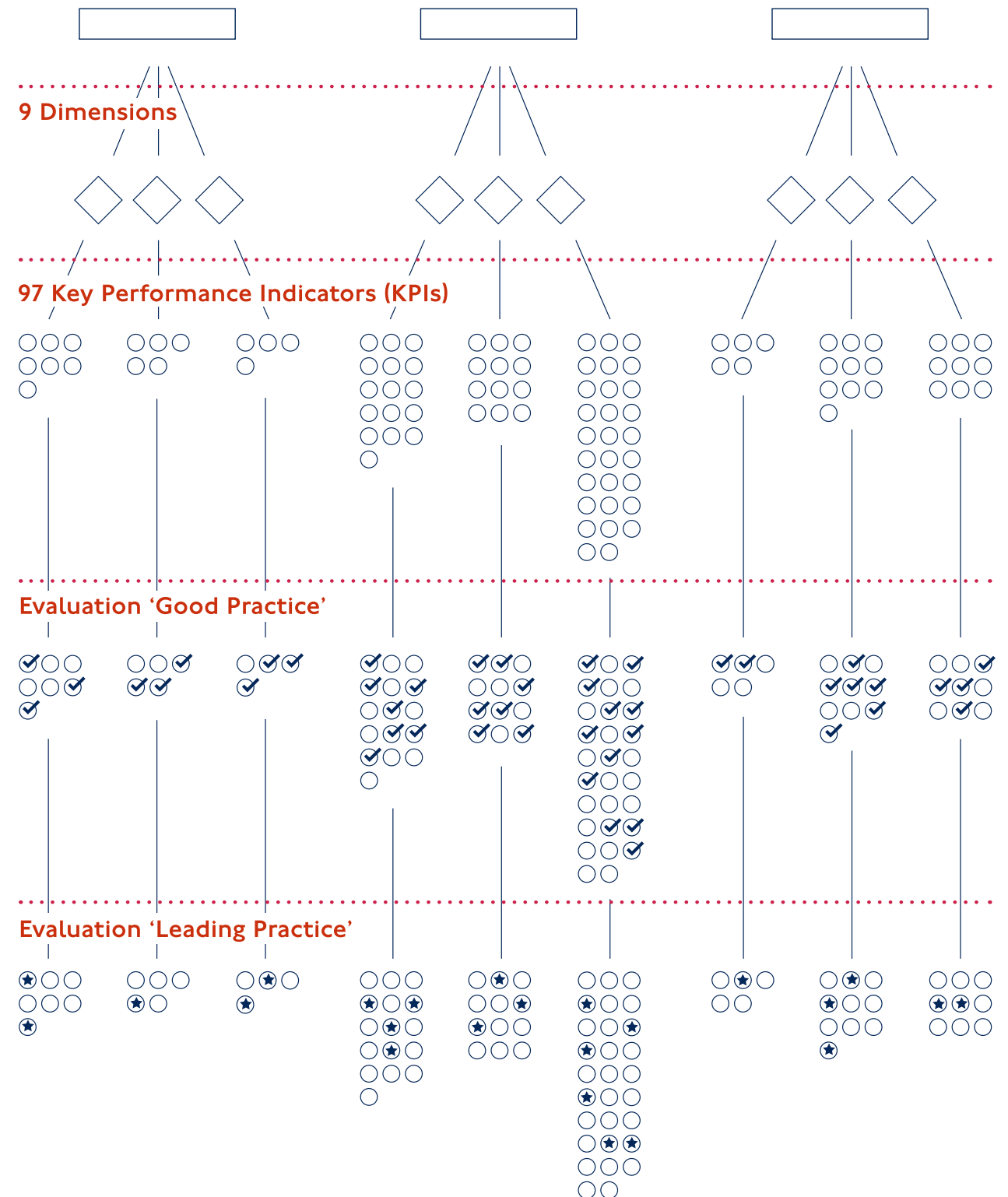

## An Introduction to the Indicators

Each Indicator has been carefully benchmarked against policy, existing guidance and example projects to create performance bands ranging from ‘Good Practice’ to ‘Leading Practice’. The expectation is that our own projects will sit within these performance bands for each Indicator.

Good Practice is, where applicable, generally aligned with current policy requirements. It is set at a high standard but one that most projects should be able to achieve with good planning early on and engagement from the full project team.

Leading Practice, meanwhile, provides a target that will stretch projects to strive for true industry leadership.



For a project to truly contribute to a sustainable London, it must work holistically, performing well against all Dimensions, both individually and collectively.

How and when to apply the Indicators is covered in more detail in [Part 2: the SDF in Action](#).

Ongoing development There are currently a small number of Indicators which are under review as we gather data or refine the detail. These have been included here to show the breadth of the Framework, and will be updated in due course.

In the next stages we will also publish detailed Technical Guidance documents for each Dimension that complement this handbook. These will provide further information on the Indicator, including how it is calculated, a step by step process for implementing it through the RIBA Work Stages, and links to policy and further reading.

## Key

LPI	Apprenticeships	Measures the number ...
ID	Indicator	What it does
The alphanumeric code of the Indicator	The name of the Indicator	A very brief summary of the process or outcome targeted by the Indicator
<input type="checkbox"/> Residential <input checked="" type="checkbox"/> Commercial <input checked="" type="checkbox"/> Masterplan	 3-6	# Numerical
Applies to	RIBA Stage	Metric
What type of development Indicator applies to	The RIBA stage at which the Indicator is applicable	The way the Indicator is measured
Number of Apprenticeships		
Unit	Range	
The individual unit into which the Indicator can be broken down	The relationship between Good and Leading practice for each Indicator	

## The Nine Dimensions





The SDF Dimensions are:

Promoting Vibrant and Diverse Communities

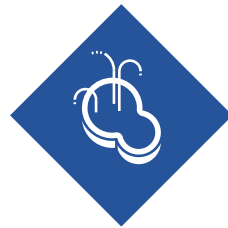

#1  
Vibrant  
Places



#2  
Social  
Cohesion



#3  
Liveable  
Communities

Creating Healthy Places for People and Planet

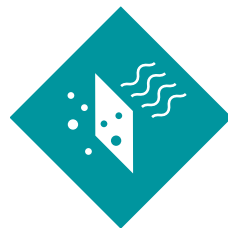

#4  
Health and  
Wellbeing



#5  
Climate and  
Ecological Resilience



#6  
High Performance  
Buildings

Supporting and Developing Local Economies

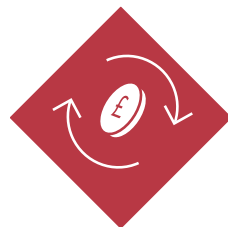

#7  
Financial  
Sustainability



#8  
Local  
Prosperity

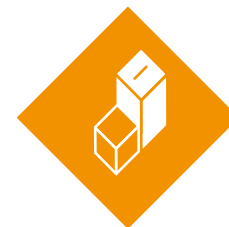

#9  
Neighbourhood  
Investment

The following sections give an overview of each Dimension, supported by example projects from our portfolio. There is also a summary table showing the Indicators that make up each Dimension.

**#1—3**  
**Promoting Vibrant and**  
**Diverse Communities**

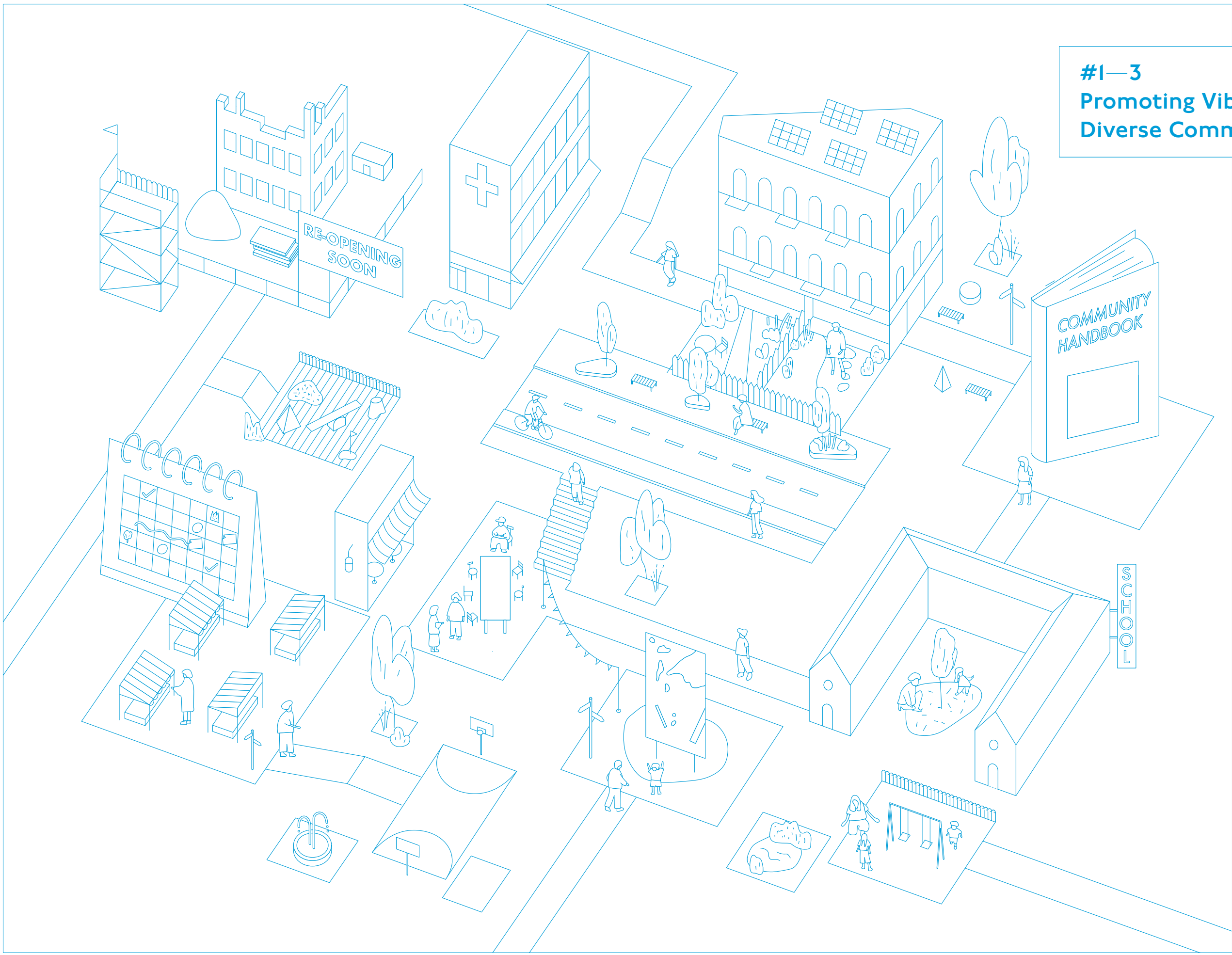



## Dimension #1 Vibrant Places [VP]

The Vibrant Places Dimension articulates the value of good public realm and building design to the city, its streets and people. It is about creating dynamic, inclusive and accessible places that make a positive contribution to neighbourhoods: attractive, people-friendly streets that feel safe and don't pose barriers to children or the physically impaired.

While many of the areas covered by this Dimension are already well understood, we have combined qualitative and quantitative measures to ensure that the starting points for design are about prioritising vibrancy, interest and legibility.

At the core of this Dimension are existing Indicators such as Healthy Streets. To ensure the focus is on genuinely inclusive people-friendly places, we have also developed and drawn on a range of additional Indicators.

Our approach has led to a set of Indicators that:

- Create high quality places that are greener, healthier, and more attractive for living, working, playing, and doing business;
- Deliver public realm that is accessible to everyone regardless of ability, age, gender, or income; and
- Contribute to dynamic neighbourhoods through engaging facades and active frontages, which provide interest and add value to the streetscape.

At the heart of this Dimension is a holistic emphasis on place – the facades, streets and spaces that are the backdrop to everyday life, creating places where people can flourish.

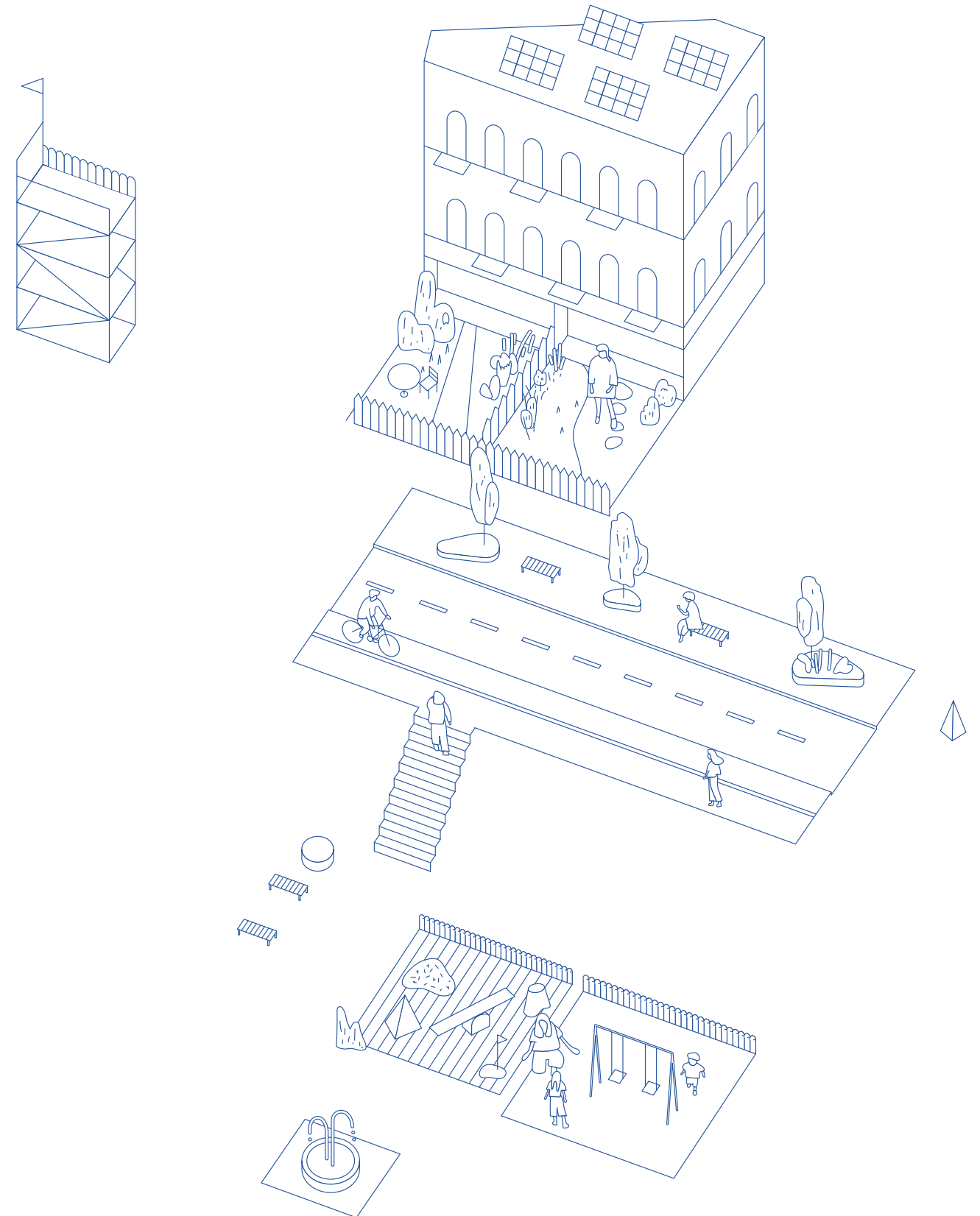



# Vibrant Places Indicators

ID	Indicator	What it does	Applies to	RIBA Stages	Metric	Unit	Range	✓ Good practice ★ Leading practice
VP 1	Healthy Streets	Uses TfL's 'Healthy Streets Check for Designers' to assess and improve a streetscape in line with the ten principles of the Healthy Streets Approach	<input checked="" type="checkbox"/> Residential <input checked="" type="checkbox"/> Commercial <input checked="" type="checkbox"/> Masterplan	○ ● ● ● ● ● ● ● 1-7	% Percentage	Percentage score of assessed street(s)	0 <span style="float:right">85% ★</span> 65% ✓ 100%	
VP 2	Access & Inclusion	Supports making streets, public spaces and developments inclusive and accessible to everyone	<input checked="" type="checkbox"/> Residential <input checked="" type="checkbox"/> Commercial <input checked="" type="checkbox"/> Masterplan	● ● ● ● ● ● ● ● 0-7	✓ Workstage Involvement	Appointment of access consultant to be embedded in team for project duration and POE	0 <span style="float:right">7 ★</span> 6 ✓	
VP 3	Child Friendly Design	Scores a project on the basis of how child-friendly it is on a micro and macro scale	<input checked="" type="checkbox"/> Residential <input checked="" type="checkbox"/> Commercial <input checked="" type="checkbox"/> Masterplan	○ ● ● ● ● ● ● ○ 1-6	○ Points	Maximum 60 points – Traffic Light Scoring System	1 <span style="float:right">48 ★</span> 36 ✓ 60	
VP 4	Playspace for Teenagers	Encourages playspace for teenagers of all genders	<input checked="" type="checkbox"/> Residential <input type="checkbox"/> Commercial <input checked="" type="checkbox"/> Masterplan	○ ● ● ○ ○ ● ● ● 1-2, 5-7	○ Points	Provision / POE and remedial work	● <span style="float:right">POE ★</span> ✓ Implementation	
VP 5	Age Friendly Design	Assesses designs against the University of Stirling's 'Dementia Design Audit Tool'	<input checked="" type="checkbox"/> Residential <input checked="" type="checkbox"/> Commercial <input checked="" type="checkbox"/> Masterplan	○ ● ● ● ● ○ ○ ● 1-4, 7	% Percentage	Aggregate percentage score on applicable checklists	0 <span style="float:right">80% ★</span> 60% ✓ 100%	
VP 6	Active Frontages	Promotes active facades for buildings at ground-floor level	<input checked="" type="checkbox"/> Residential <input checked="" type="checkbox"/> Commercial <input checked="" type="checkbox"/> Masterplan	○ ● ● ● ● ● ● ○ 1-6	∶ Ratio	Proportion of active ground floor by linear metre	0.00 <span style="float:right">0.80 ★</span> ✓ 0.50 1.00	
VP 7	Secure Developments	Supports consultation with crime prevention and operational security specialists throughout the design, construction and completion of a project	<input checked="" type="checkbox"/> Residential <input checked="" type="checkbox"/> Commercial <input checked="" type="checkbox"/> Masterplan	○ ● ● ● ● ● ● ○ 1-6	✓ Workstage Involvement	Appointment of Crime Reduction Specialist for project duration and POE	0 <span style="float:right">7 ★</span> 6 ✓	

## Dimension #2 Social Cohesion [SC]

The Social Cohesion Dimension focuses on how our projects can engage communities and bring them together. It goes beyond our responsibility to be transparent and open about our work by setting out beneficial ways of engaging before, during and after a project's construction. The result should be residents and communities who feel a greater sense of local pride and belonging, with spaces and activities planned for them.

Engagement should focus on people affected by a project, especially those without the necessary assets or formal political power to directly control what happens. This Dimension helps ensure their voices are represented and their perspectives understood. Supported by our Community Engagement Handbook, it aims to make the engagement process more transparent, impactful, and inclusive.

Of the many benefits stemming from a good engagement programme, we have crafted the Indicators to make sure we are:

- Communicating proactively and regularly;
- Listening to local concerns and addressing difficult issues;
- Building quality relationships with stakeholders that can continue long after the project is complete;
- Benefitting from local knowledge and expertise;
- Building trust and strengthening connections within the community.

Fundamentally we are promoting engagement that is creative, inclusive, sensitive, and planned to take place at every stage of the project. In doing so, we hope the way we manage the potentially disruptive process of change will ultimately strengthen social bonds and help make communities more integrated and inclusive.

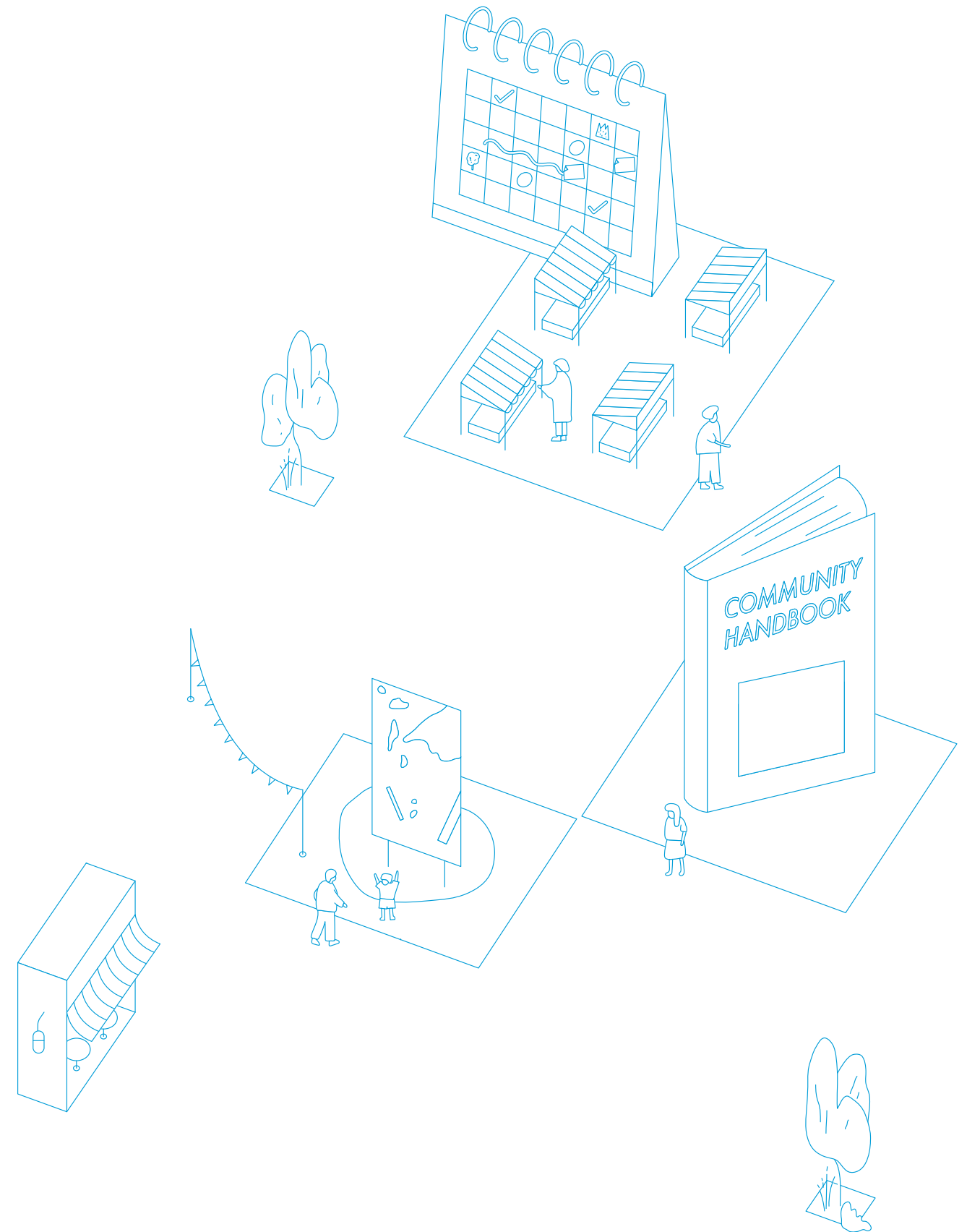



## Social Cohesion Indicators

ID	Indicator	What it does	Applies to	RIBA Stages	Metric	Unit	Range	✓ Good practice ★ Leading practice
SC1	Community Engagement before and during planning	Encourages meaningful engagement with local communities up to a planning submission	<input checked="" type="checkbox"/> Residential <input checked="" type="checkbox"/> Commercial <input checked="" type="checkbox"/> Masterplan	●●●○○○○○ 0–2	% Percentage	Percentage	Percentage of best practices implemented	0 <span style="float: right;">80% ★</span> 0 ✓ 50% 100%
SC2	Community Engagement after planning	Encourages meaningful engagement with local communities after the planning submission and during construction	<input checked="" type="checkbox"/> Residential <input checked="" type="checkbox"/> Commercial <input checked="" type="checkbox"/> Masterplan	○○○●●●●○ 3–6	% Percentage	Percentage	Percentage of best practices implemented	0 <span style="float: right;">80% ★</span> 0 ✓ 50% 100%
SC3	Engagement with Seldom Heard Groups	Encourages meaningful engagement with seldom heard groups	<input checked="" type="checkbox"/> Residential <input checked="" type="checkbox"/> Commercial <input checked="" type="checkbox"/> Masterplan	●●●●●○○○ 0–5	% Percentage	Percentage	Percentage of best practices implemented	0 <span style="float: right;">80% ★</span> 0 ✓ 50% 100%
SC4	Active Public Spaces	Promotes the designation of a part of the site for public use	<input checked="" type="checkbox"/> Residential <input checked="" type="checkbox"/> Commercial <input checked="" type="checkbox"/> Masterplan	○●●●●●●● 1–7	% Percentage	Percentage	Percentage of publicly accessible site area for active public use	
SC5	Active Community Programming	Measures the time that planned activities take place on the public space provided by the new development	<input checked="" type="checkbox"/> Residential <input checked="" type="checkbox"/> Commercial <input checked="" type="checkbox"/> Masterplan	○●●●○○●● 1–3, 6–7	% Percentage	Percentage	Percentage of available time each year that public space is used by the public	



## Dimension #3 Liveable Communities [LC]

In this Dimension we set out the ways in which our development will improve the liveability of London’s neighbourhoods. These elements range from genuinely affordable homes to the spaces and places that people meet in and includes the services that support everyday life.

New development can alter or disrupts the current balance of community infrastructure. The Indicators here help us understand the current situation and enhance it through the changes brought about by a project.

Our Indicators cover a deliberate range to help us balance targets around the delivery of homes alongside local responses that enhance nearby amenities.

In this way our development processes:

- Balance targets for the delivery of new homes with enhancements to local amenities;
- Measure the number of genuinely affordable homes we are building;
- Improve routes through a neighbourhood or link it to nearby amenities; and
- Activate underused spaces by providing opportunities for short-term uses.

For us, community infrastructure is a delicate thing; every site will require a different approach based on research and engagement. The strong links to the Social Cohesion Dimension allow us to be responsive to this challenge. It means that a community facility is more than just a building – it is a space that plays a part in the civic life of our city, and contributes to the quality of life in London.

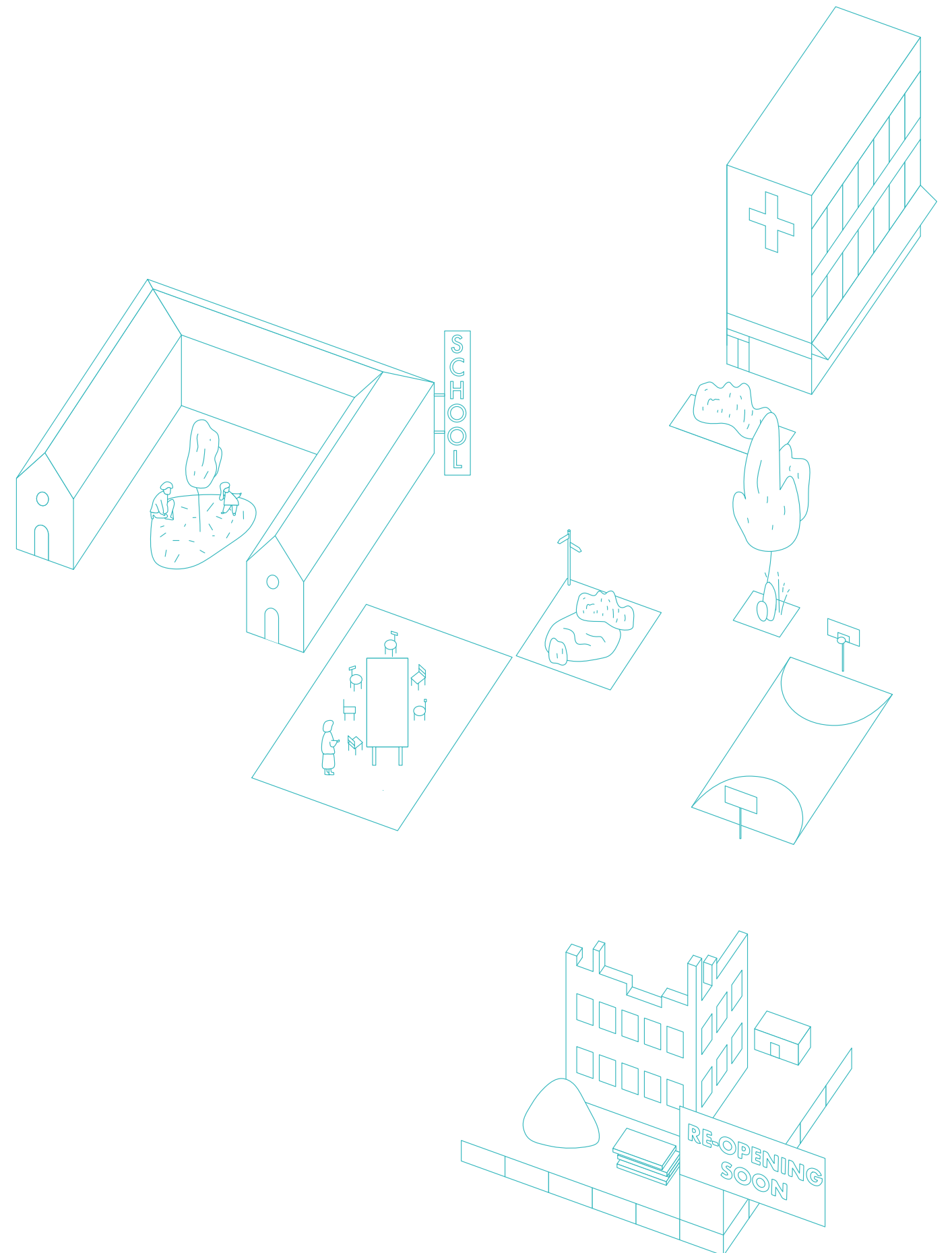



## Liveable Communities Indicators

ID	Indicator	What it does	Applies to	RIBA Stages	Metric	Unit	Range	✓ Good practice ★ Leading practice
LC1	Meanwhile	Supports provision of opportunities for short-term uses of vacant or underused spaces	<input checked="" type="checkbox"/> Residential <input checked="" type="checkbox"/> Commercial <input checked="" type="checkbox"/> Masterplan	○ ● ● ● ○ ● ● ○ I-2, 4, 6	○ Points	Feasibility study (1) / meanwhile space (2) / permanent (3)	● ✓ 1	● 3 ★ 3
LC2	New Routes and Links	Supports creation of new routes and links between the new development and the existing neighbourhood	<input checked="" type="checkbox"/> Residential <input checked="" type="checkbox"/> Commercial <input checked="" type="checkbox"/> Masterplan	○ ● ● ○ ○ ● ○ ○ I-2, 5	○ Points	New Route or Link (1) / improved PTAL (2)	● ✓ 1	★ 2 ●
LC3	New Local Amenities	Encourages providing new local amenities as part of the development	<input checked="" type="checkbox"/> Residential <input checked="" type="checkbox"/> Commercial <input checked="" type="checkbox"/> Masterplan	○ ● ● ○ ○ ○ ● ○ I-2, 6	✓ ✕ Pass / Fail	Provision	✕ Fail: not provided ✓ Pass: provided	
LC4	Affordable Homes	Measures how much affordable housing a development delivers	<input checked="" type="checkbox"/> Residential <input type="checkbox"/> Commercial <input checked="" type="checkbox"/> Masterplan	○ ● ● ● ● ● ○ ○ I-5	% Percentage	Percentage of habitable rooms	exceeding policy ★ meeting policy ✓	



**#4—6**  
**Creating Healthy Places**  
**for People and Planet**

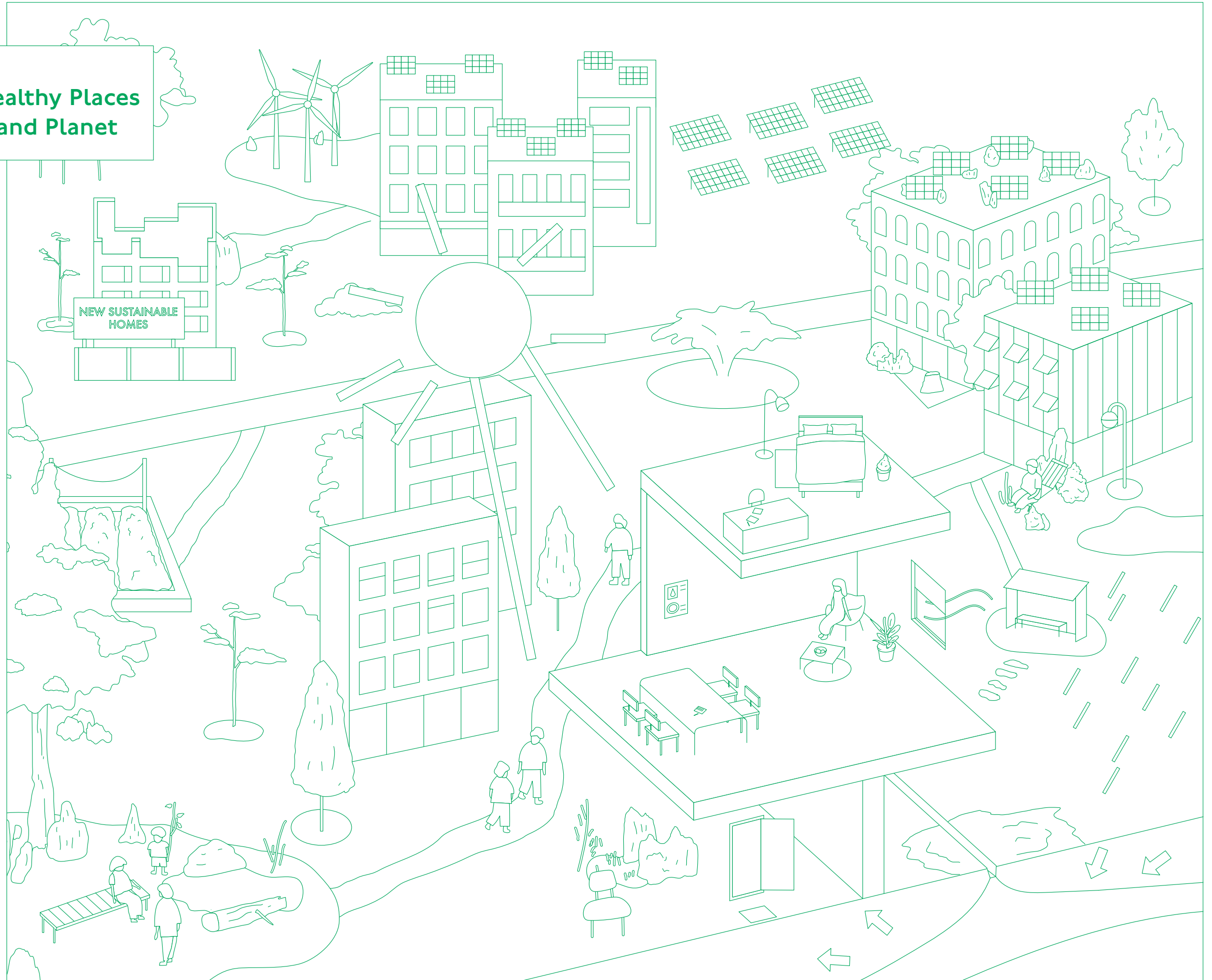

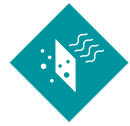

## Dimension #4 Health and Wellbeing [HW]

The Health and Wellbeing Dimension is concerned with the impacts of our developments on the health and wellbeing not just of their occupants but the local community in general. It therefore puts significant emphasis on finding ways to reduce exposure to harmful pollution across London, minimising disruption during the construction process and tackling health inequality.

For the development, this Dimension emphasises the need for high quality internal spaces to improve people's health, wellbeing and productivity. This is a holistic approach that addresses psychological and physical factors both during construction and in occupation.

Our Indicators here are well supported by industry guidance and techniques, with a particular focus on issues associated with transport-oriented development, such as noise, vibration, and air quality.

Our Indicators:

- Seek to improve local air quality through the buildings themselves and by encouraging sustainable methods of travel;
- Give occupants the ability to control their indoor environments for maximum comfort;
- Promote attributes such as natural light that have a positive effect on mental and physical health; and
- Minimise the potentially harmful impacts of construction on health and wellbeing.

The increased need for homes and workplaces that support health and wellbeing is well documented, as are the benefits of designing with these principles in mind. This Dimension sets objectives that translate those principles into real environments that have a positive effect on mental and physical wellbeing throughout the lifecycle of a project.

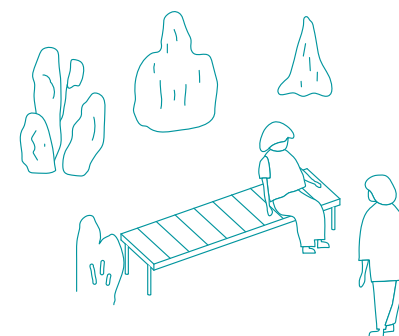
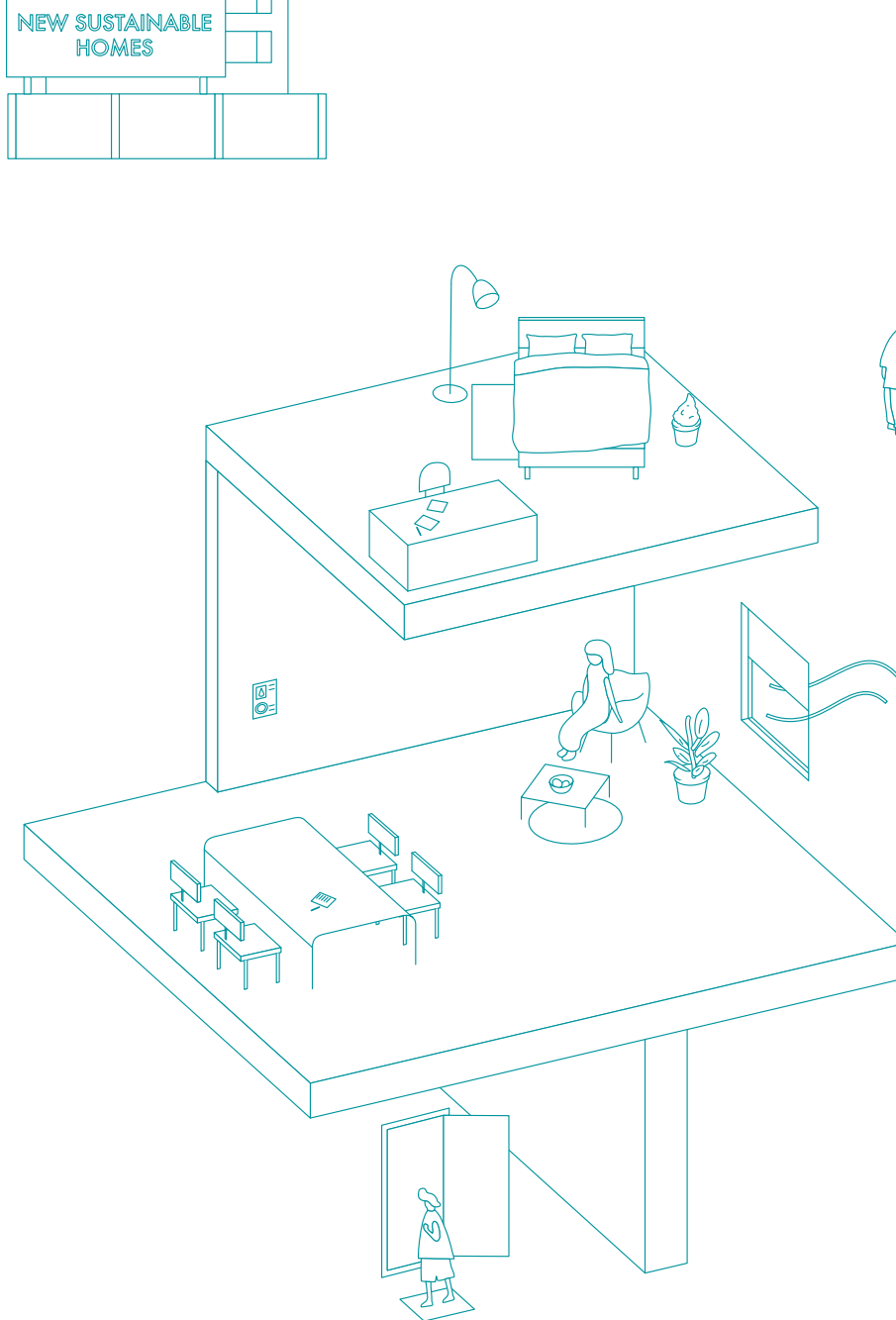
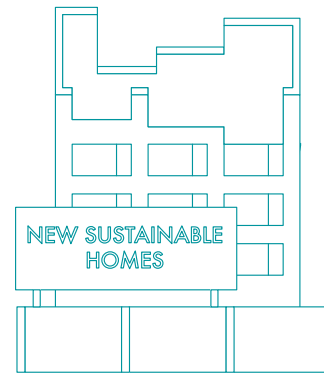

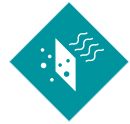

# Health and Wellbeing Indicators

ID	Indicator	What it does	Applies to	RIBA Stages	Metric	Unit	Range	✓ Good practice ★ Leading practice
HW1	Outdoor Air Quality – Transport Residential	Aims to use residential transport strategies that reduce pollution and improve air quality, for example by encouraging cycling, walking and use of public transport	<input checked="" type="checkbox"/> Residential <input type="checkbox"/> Commercial <input type="checkbox"/> Masterplan	●○○●○○●○○ 0, 2, 5, 7	% Percentage	Percentage of improvement on AQN Benchmark	✓ 0% <span style="float: right;">85% ★</span> 100%	
HW2	Outdoor Air Quality – Transport Commercial	Aims to reduce pollution caused by commercial traffic and improve air quality in the area	<input type="checkbox"/> Residential <input checked="" type="checkbox"/> Commercial <input checked="" type="checkbox"/> Masterplan	●○○●○○●○○ 0, 2, 5, 7	% Percentage	Percentage of improvement on AQN Benchmark	✓ 0% <span style="float: right;">85% ★</span> 100%	
HW3	Outdoor Air Quality – Buildings	Aims to improve the external air quality of an area long term by eliminating combustion plant systems	<input checked="" type="checkbox"/> Residential <input checked="" type="checkbox"/> Commercial <input checked="" type="checkbox"/> Masterplan	●○○●○○●○○ 0, 2, 5, 7	% Percentage	Percentage of improvement on AQN Benchmark	✓ 0% <span style="float: right;">100% ★</span> 100%	
HW4	Thermal Comfort – Homes DSY1	Conducts a thermal analysis against the adaptive criteria requirements for CIBSE DSY 1 2020s weather files (a moderately warm summer)	<input checked="" type="checkbox"/> Residential <input type="checkbox"/> Commercial <input type="checkbox"/> Masterplan	○●●●○○○○○ 1-3	% Percentage	Compliance with CIBSE TM59 under DSY 1	0 <span style="float: right;">100% ✓ ★</span> 100%	
HW5	Thermal Comfort – Homes DSY2	Conducts a thermal analysis against the adaptive criteria requirements for CIBSE DSY 2 2020s weather files (a short, intense warm spell)	<input checked="" type="checkbox"/> Residential <input type="checkbox"/> Commercial <input type="checkbox"/> Masterplan	○●●●○○○○○ 1-3	% Percentage	Compliance with CIBSE TM59 under DSY 2	0 <span style="float: right;">100% ★</span> 100%	
HW6	Thermal Comfort – Homes DSY3	Conducts a thermal analysis against the adaptive criteria requirements for CIBSE DSY 3 2020s weather files (a long, less intense warm spell)	<input checked="" type="checkbox"/> Residential <input type="checkbox"/> Commercial <input type="checkbox"/> Masterplan	○●●●○○○○○ 1-3	% Percentage	Compliance with CIBSE TM59 under DSY 3	0 <span style="float: right;">100% ★</span> 100%	
HW7	Thermal Comfort – Commercial	Ensures the building can provide an appropriate level of thermal comfort for its users according to BREEAM criteria	<input type="checkbox"/> Residential <input checked="" type="checkbox"/> Commercial <input checked="" type="checkbox"/> Masterplan	●●●●●○○● 0-4, 7	○ Points	Number of Credits – BREEAM Hea 04	1 <span style="margin-left: 100px;">2</span> <span style="float: right;">3</span> ✓ 2 3	3 ★

ID	Indicator	What it does	Applies to	RIBA Stages	Metric	Unit	Range	✓ Good practice ★ Leading practice
HW 8	Indoor Air Quality – Residential	Aims to minimise indoor air pollutants emitted by a building and its materials, using HQM criteria	<input checked="" type="checkbox"/> Residential <input type="checkbox"/> Commercial <input type="checkbox"/> Masterplan	●●●●●●○ 0–6	○ Points	Number of Credits – HQM 4.1	●●●●●●●●●●●●   6 12	12 ★
HW 9	Indoor Air Quality – Commercial	Considers air pollution early in the design process to allow a mitigation strategy to be put in place	<input type="checkbox"/> Residential <input checked="" type="checkbox"/> Commercial <input checked="" type="checkbox"/> Masterplan	●●●●●●●● 0–7	○ Points	Number of Credits – BREEAM Hea 02	●●●●●●●●   4 5	5 ★
HW 10	Noise and Vibration – Residential	Aims to minimise noise disturbance by both reducing noise sources and improving sound insulation	<input checked="" type="checkbox"/> Residential <input type="checkbox"/> Commercial <input type="checkbox"/> Masterplan	○●●●●●●○ 1–6	○ Points	Number of Credits – HQM 4.3 and HQM 4.4	●●●●●●●●●●●●●●   9 13	13 ★
HW 11	Acoustic Performance – Commercial	Promotes BREEAM best practice acoustic performance levels appropriate for the use of the spaces	<input type="checkbox"/> Residential <input checked="" type="checkbox"/> Commercial <input checked="" type="checkbox"/> Masterplan	○●●●●●○ 1–5	○ Points	Number of Credits – BREEAM Hea 05	●●●●●●●●   2 3	3 ★
HW 12	Daylight, Sunlight and Overshadowing	Promotes access to daylight in residential developments to improve wellbeing and reduce energy use	<input checked="" type="checkbox"/> Residential <input type="checkbox"/> Commercial <input type="checkbox"/> Masterplan	○●●●●●○ 1–5	○ Points	Number of GLA criteria met	●●●●●●●●   3 3	3 ✓ ★
HW 13	Access to Daylight – Commercial	Promotes access to daylight in commercial developments as part of best practice in visual performance and comfort	<input type="checkbox"/> Residential <input checked="" type="checkbox"/> Commercial <input checked="" type="checkbox"/> Masterplan	○●●●●○○○ 1–3	○ Points	Number of Credits – BREEAM Hea 01 – Daylighting	●●●●●●●●   1 2	2 ★
HW 14	Views of Sky – Commercial	Promotes access to external views in commercial developments to break the monotony of the indoor environment	<input type="checkbox"/> Residential <input checked="" type="checkbox"/> Commercial <input checked="" type="checkbox"/> Masterplan	●●●●●○○○ 0–4	○ Points	Number of Credits – BREEAM Hea 01	●●●●●●●●   1	1 ✓ ★
HW 15	Access to Nature	Encourages integration of nature and natural elements both inside and outside of commercial buildings	<input type="checkbox"/> Residential <input checked="" type="checkbox"/> Commercial <input checked="" type="checkbox"/> Masterplan	●●●●●○○○ 0–4	○ Points	Number of Credits – WELL v2 M 09	●●●●●●●●   1 2	2 ★
HW 16	Considerate Constructors Scheme	Measures performance of the construction site against the Considerate Constructors Scheme (CCS)	<input checked="" type="checkbox"/> Residential <input checked="" type="checkbox"/> Commercial <input checked="" type="checkbox"/> Masterplan	○●●●●○○○ 1–5	○ Points	CCS Score	●●●●●●●●●●●●●●●●   40 45 50	45 ★



## Dimension #5 Climate and Ecological Resilience [CR]

How can our developments respond to the environmental impacts of a changing climate? Guiding this Dimension is the dual focus of mitigating the effects of the climate and ecological emergency on London’s green spaces and water systems, and making sure developments improve biodiversity and access to green spaces. Reducing the risk of flooding, keeping buildings and streets cool, and increased planting are therefore central to this Dimension.

We cover areas from biodiversity and urban greening to the impact of construction on ecological systems. This Dimension takes a long-term view of development and emphasises how spaces can be made resilient. While this Dimension largely addresses external spaces, it should be read in conjunction with Dimensions #6 (High-Performance Buildings) and #4 (Health and Wellbeing), which deal more closely with the buildings themselves.

The Indicators in this Dimension focus on the ways new development can benefit local microclimates by:

- Reducing the impacts of anticipated climate change on our public realm;
- Supporting increases in biodiversity and the amount of vegetation on our land;
- Making sure our choices – from planting to drainage and paving – will be resilient to climate change;
- Protecting resources as much as we can during the construction process; and
- Sustainably managing water to futureproof London against flooding and water shortages.



An important part of this Dimension is the way it frames the landscaping of a project as an active part of the city. By highlighting this planted and paved infrastructure as a part of development we will be raising awareness and understanding of the role nature has in creating healthy environments.





## Climate and Ecological Resilience Indicators

ID	Indicator	What it does	Applies to	RIBA Stages	Metric	Unit	Range	✓ Good practice ★ Leading practice
CR1	Urban Greening – Residential	Evaluates the quantity and quality of the vegetated surfaces in a residential development	<input checked="" type="checkbox"/> Residential <input type="checkbox"/> Commercial <input checked="" type="checkbox"/> Masterplan	○ ● ● ● ● ● ● ● 1-7	# Numerical	Ratio of urban greening	0.00 — 1.00 ✓ 0.40	★ 0.50
CR2	Urban Greening – Commercial	Evaluates the quantity and quality of the vegetated surfaces in a commercial development	<input type="checkbox"/> Residential <input checked="" type="checkbox"/> Commercial <input checked="" type="checkbox"/> Masterplan	○ ● ● ● ● ● ● ● 1-7	# Numerical	Ratio of urban greening	0.00 — 1.00 ✓ 0.30	★ 0.40
CR3	Minimising Flood Risk and Maximising Flood Resilience – Residential	Promotes design features in residential developments that manage rainfall and reduce the risk of flooding for occupants and neighbours.	<input checked="" type="checkbox"/> Residential <input type="checkbox"/> Commercial <input checked="" type="checkbox"/> Masterplan	○ ● ● ● ● ● ● ● 1-7	○ Points	No. of HQM points under HQM 3.1 & 3.2	1 — 38 17 + 8 ✓	38 ★
CR4	Minimising Flood Risk and Maximising Flood Resilience – Commercial	Encourages commercial developments to avoid, reduce and delay the discharge of rainwater into public sewers and watercourses	<input type="checkbox"/> Residential <input checked="" type="checkbox"/> Commercial <input checked="" type="checkbox"/> Masterplan	○ ● ● ● ○ ○ ● ● ● 1-3, 6-7	○ Points	no. of BREEAM POL 03 credits	1 — 5 ✓ 3	5 ★
CR5	Sustainable Drainage	Assesses how well rainfall is dealt with at source	<input checked="" type="checkbox"/> Residential <input checked="" type="checkbox"/> Commercial <input checked="" type="checkbox"/> Masterplan	○ ● ● ● ● ● ● ● 1-7	% Percentage	Percentage of rainwater discharged via stages 1-3 of the London Plan hierarchy	0 — 100% ✓ 50%	100% ★
CR6	Biodiversity	Calculates the amount of habitat retained, created or enhanced by development	<input checked="" type="checkbox"/> Residential <input checked="" type="checkbox"/> Commercial <input checked="" type="checkbox"/> Masterplan	○ ● ● ● ● ● ● ● 1-7	% Percentage	Percentage change in biodiversity	0 — 100% ✓ 10%	100% ★
CR7	Soils Protection	Establishes good practice in the protection of inherited carbon in soils, the sustainable use of soils in development and the capture of carbon through site substrate	<input checked="" type="checkbox"/> Residential <input checked="" type="checkbox"/> Commercial <input checked="" type="checkbox"/> Masterplan	○ ● ● ○ ● ● ● ○ 1-2, 4-6	○ Points	No. of good practice actions		

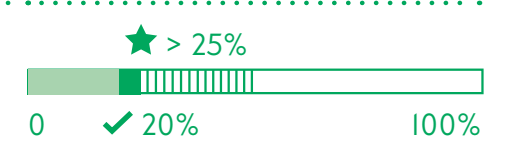
ID	Indicator	What it does	Applies to	RIBA Stages	Metric	Unit	Range	<input checked="" type="checkbox"/> Good practice <input checked="" type="checkbox"/> Leading practice
CR8	Landscape Future-Proofing	Measures the degree to which landscaped areas are more resilient to the effects of climate change	<input checked="" type="checkbox"/> Residential <input checked="" type="checkbox"/> Commercial <input type="checkbox"/> Masterplan	○ ● ● ● ● ● ● ● 1-7	○ Points	Points for planning and establishment	 1 8 18	18 ★
CR9	Construction Impacts on Ecology – Residential	Aims to avoid, or limit as far as possible, any negative impacts on the ecology of the site in residential developments	<input checked="" type="checkbox"/> Residential <input type="checkbox"/> Commercial <input checked="" type="checkbox"/> Masterplan	○ ● ● ○ ● ● ○ ○ 1-2, 4-5	○ Points	HQM Credits	 0 6+6 ✓ 16	7 + 9 ★
CR10	Construction Impacts on Ecology – Commercial	Aims to avoid, or limit as far as possible, any negative impacts on the ecology of the site in commercial developments	<input type="checkbox"/> Residential <input checked="" type="checkbox"/> Commercial <input checked="" type="checkbox"/> Masterplan	○ ● ● ○ ● ○ ● ○ 1-2, 4, 6	○ Points	BREEAM Credits	 0 4 ✓ 6	6 ★
CR11	Tree Canopy Cover	Calculates how much of the site area will be covered by trees roughly 20 years after completion	<input checked="" type="checkbox"/> Residential <input checked="" type="checkbox"/> Commercial <input checked="" type="checkbox"/> Masterplan	○ ● ● ● ● ● ● ● 1-7	% Percentage	m <sup>2</sup> of canopy cover	 0 ✓ 20% 100%	★ > 25%
CR12	Tree Planting	Records the number of trees planted	<input checked="" type="checkbox"/> Residential <input checked="" type="checkbox"/> Commercial <input checked="" type="checkbox"/> Masterplan	○ ○ ○ ○ ● ○ ● ○ ○ 4, 6	# Numerical	No. of trees planted	Reporting	



## Dimension #6 High Performance Buildings [HPB]

As the name suggests, the aim of this Dimension is to make the environmental performance of our buildings exceptional.

Several areas of the lifecycle of a building are underrepresented in current policy and standard industry practice; this Dimension seeks to address this, at the same time as emphasising how we might holistically reduce carbon emissions as part of the fight against climate change. To reduce energy and water use, buildings might incorporate smart technologies and green energy generators.

Many of the Indicators within this Dimension work together to ensure we achieve net zero carbon by 2030 – not just in terms of design intent, but in practice and operation. They also seek to minimise what can often be a large gap between the theoretical performance of a building and its performance in practice.

For us, a High Performance Building is one that:

- Allows us to achieve net zero carbon by 2030 at the latest;
- Is considerate of resources such as water and energy, and minimises waste;
- Promotes circular economy principles and the use of sustainable and responsible materials;
- Adapts to future demands and where possible generates its own energy; and
- Is easy to operate and performs as designed, in ways that can be monitored in the long term.

These highly quantitative Indicators provide us with a clear path to net-zero emissions and help ensure our buildings perform at the highest level in practice.

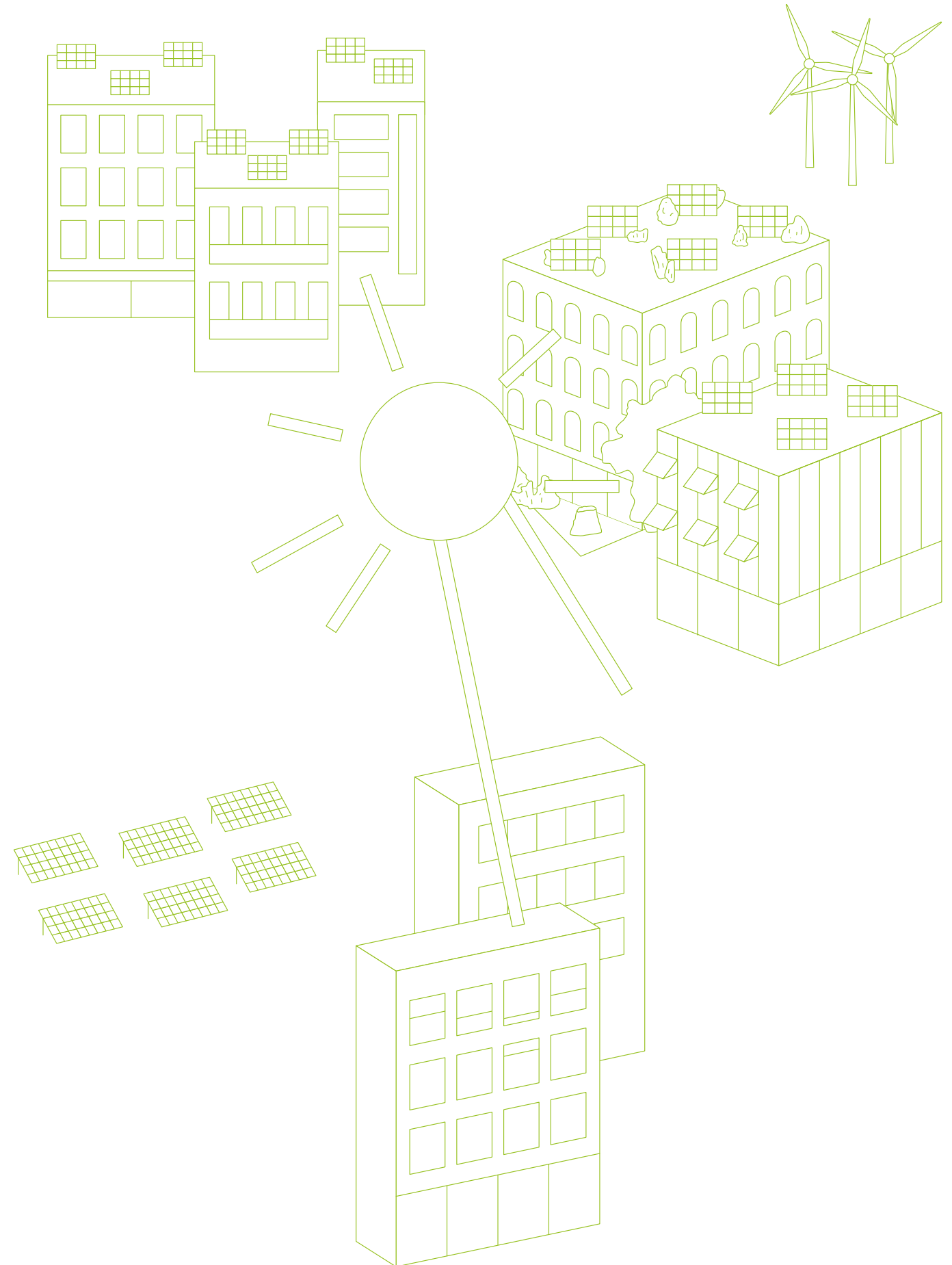





## High Performance Buildings Indicators

ID	Indicator	What it does	Applies to	RIBA Stages	Metric	Unit	Range	✓ Good practice ★ Leading practice
HPB1	Embodied Carbon Intensity – Residential	Calculates the amount of upfront embodied carbon in a building, taking into account the emissions associated with the materials used	<input checked="" type="checkbox"/> Residential <input type="checkbox"/> Commercial <input checked="" type="checkbox"/> Masterplan	○ ● ● ● ● ● ● ● ● 1-7	# Numerical	Embodied Carbon Intensity (kg CO <sup>2</sup> e / m <sup>2</sup> )	★ 300 kg 250 650 kg ✓ 1000	
HPB2	Embodied Carbon Intensity – Commercial	Calculates the amount of upfront embodied carbon in a building, taking into account the emissions associated with the materials used	<input type="checkbox"/> Residential <input checked="" type="checkbox"/> Commercial <input checked="" type="checkbox"/> Masterplan	○ ● ● ● ● ● ● ● ● 1-7	# Numerical	Embodied Carbon Intensity (kg CO <sup>2</sup> e / m <sup>2</sup> )	★ 350 kg 250 750 kg ✓ 1000	
HPB3	Embodied Carbon Offset	Calculates the proportion of any remaining carbon emissions not already included in other KPIs that are offset	<input checked="" type="checkbox"/> Residential <input checked="" type="checkbox"/> Commercial <input checked="" type="checkbox"/> Masterplan	○ ● ● ● ● ● ● ● ● 1-7	% Percentage	Percentage of Remaining Emissions Offset		
HPB4	Recycled Materials	Calculates the percentage of construction materials that are recycled	<input checked="" type="checkbox"/> Residential <input checked="" type="checkbox"/> Commercial <input checked="" type="checkbox"/> Masterplan	○ ● ● ● ● ● ● ● ● 1-7	% Percentage	Materials percentage recycled content, by value	★ 30% 0 ✓ 20% 100%	
HPB5	Responsible Sourcing – Residential	Encourages the use of construction products from supply chains that follow sustainable development principles	<input checked="" type="checkbox"/> Residential <input type="checkbox"/> Commercial <input checked="" type="checkbox"/> Masterplan	○ ● ● ● ● ● ● ● ● 1-7	○ Points	Number of Credits – HQM 6.1	25 ★ 1 ✓ 13 25	
HPB6	Responsible Sourcing – Commercial	Encourages the use of construction products from supply chains that follow sustainable development principles	<input type="checkbox"/> Residential <input checked="" type="checkbox"/> Commercial <input checked="" type="checkbox"/> Masterplan	○ ● ● ● ● ● ● ● ● 1-7	○ Points	Number of Credits – BREEAM Mat 03	5 ★ 1 ✓ 3 5	
HPB7	Operational Energy Use – Residential	Measures the total annual energy consumption of a building, including from heating, hot water, cooling, ventilation, lighting, equipment, appliances and cooking	<input checked="" type="checkbox"/> Residential <input type="checkbox"/> Commercial <input checked="" type="checkbox"/> Masterplan	○ ● ● ● ● ● ● ● ● 1-7	# Numerical	Metered Energy Use Intensity (kWh/m <sup>2</sup> GIA/yr)	★ 35 kWh 20 ✓ 70 kWh 180	
HPB8	Operational Energy Use – Commercial	Measures the total annual energy consumption of a building, including from heating, hot water, cooling, ventilation, lighting, equipment, appliances and cooking	<input type="checkbox"/> Residential <input checked="" type="checkbox"/> Commercial <input checked="" type="checkbox"/> Masterplan	○ ● ● ● ● ● ● ● ● 1-7	# Numerical	Metered Energy Use Intensity (kWh/m <sup>2</sup> GIA/yr)	★ 55 kWh 40 ✓ 110 kWh 215	

ID	Indicator	What it does	Applies to	RIBA Stages	Metric	Unit	Range	✓ Good practice ★ Leading practice
HPB9	Regulated Emissions – Energy Efficiency – Be Lean Residential	Aids reduction of regulated carbon emissions by promoting passive design and energy efficiency measures	<input checked="" type="checkbox"/> Residential <input type="checkbox"/> Commercial <input checked="" type="checkbox"/> Masterplan	○●●●●●●● 1–7	% Percentage	Percent reduction – Be Lean Stage of GLA Energy Hierarchy	-100% <span style="float:right">-30% ★</span> <span style="float:right">-10% ✓</span>	
HPB10	Regulated Emissions – Energy Efficiency – Be Lean Commercial	Aids reduction of regulated carbon emissions by promoting passive design and energy efficiency measures	<input type="checkbox"/> Residential <input checked="" type="checkbox"/> Commercial <input checked="" type="checkbox"/> Masterplan	○●●●●●●● 1–7	% Percentage	Percent reduction – Be Lean Stage of GLA Energy Hierarchy	-100% <span style="float:right">-35% ★</span> <span style="float:right">-15% ✓</span>	
HPB11	Regulated Emissions – Green Energy – Be Green Residential	Encourages production, storage and use of renewable energy on site in residential schemes	<input checked="" type="checkbox"/> Residential <input type="checkbox"/> Commercial <input checked="" type="checkbox"/> Masterplan	○○●●●○●● 2–4, 6–7	% Percentage	Percent reduction – Be Green Stage of GLA Energy Hierarchy	-100% <span style="float:right">★ -75%</span> <span style="float:right">-50% ✓</span> 0	
HPB12	Regulated Emissions – Green Energy – Be Green Commercial	Encourages production, storage and use of renewable energy on site in residential schemes	<input type="checkbox"/> Residential <input checked="" type="checkbox"/> Commercial <input checked="" type="checkbox"/> Masterplan	○○●●●○●● 2–4, 6–7	% Percentage	Percent reduction – Be Green Stage of GLA Energy Hierarchy	-100% <span style="float:right">★ -55%</span> <span style="float:right">-40% ✓</span> 0	
HPB13	Regulated Emissions – Monitoring – Be Seen best practices	Requires energy consumption to be estimated at both the planning and as-built stages, then monitored when the development is in use	<input checked="" type="checkbox"/> Residential <input checked="" type="checkbox"/> Commercial <input checked="" type="checkbox"/> Masterplan	○●●●●○●● 1–4, 6–7	○ Points	Pass/Fail – ‘Be Seen’ Energy Monitoring Requirements	● ● ● ○ ○ ○ ✓ Pass <span style="float:right">★ Pass + 2</span> 6	
HPB14	Regulated Emissions – Operational Net Zero	Measures operational carbon offset payment to Local Authority to achieve operational net zero	<input checked="" type="checkbox"/> Residential <input checked="" type="checkbox"/> Commercial <input checked="" type="checkbox"/> Masterplan	○●●●●○●● 1–4, 6–7	£ Financial	Financial Contribution	✓ ★ Pass	

ID	Indicator	What it does	Applies to	RIBA Stages	Metric	Unit	Range	✓ Good practice ★ Leading practice
HPB15	Bio-Solar Roof Area	Maximises the area of rooftop space that combines biodiverse roof with photovoltaic panels	<input checked="" type="checkbox"/> Residential <input checked="" type="checkbox"/> Commercial <input checked="" type="checkbox"/> Masterplan	○●●●●●●● 1-7	% Percentage	Percentage of Available Area	0 <span style="float:right">100%</span> 	100% ✓ ★
HPB16	Green Energy	Measures energy supplied by external sources (rather than on-site renewable generation), and the proportion of this that is procured through Power Purchase Agreements (PPAs) and Green Tariffs	<input checked="" type="checkbox"/> Residential <input checked="" type="checkbox"/> Commercial <input checked="" type="checkbox"/> Masterplan	○●●●●○●● 1-4, 6-7	% Percentage	Percentage of Remaining Energy met through PPA's and Green Tariffs	0 <span style="float:right">100%</span> 	100% communal and tenant areas covered ★ ✓ All communal areas covered
HPB17	Water Efficiency – Residential	Examines measures taken to reduce mains water usage	<input checked="" type="checkbox"/> Residential <input type="checkbox"/> Commercial <input type="checkbox"/> Masterplan	○●●●●●●● 1-7	○ Points	Number of Credits – HQM 8.1	●●●●●●●● 1 <span style="float:right">17</span> ✓ 8	17 ★
HPB18	Water Efficiency – Commercial	Examines measures taken to reduce unnecessary use of fresh drinking water and promotes water recycling systems	<input type="checkbox"/> Residential <input checked="" type="checkbox"/> Commercial <input checked="" type="checkbox"/> Masterplan	○●●●●●●● 1-7	○ Points	Number of Credits – BREEAM Wat 01	●●●●●●●● 1 <span style="float:right">6</span> ✓ 3	6 ★
HPB19	Smart Building Technologies – Residential	Supports the building of homes that cater for new technology and digital lifestyles	<input checked="" type="checkbox"/> Residential <input type="checkbox"/> Commercial <input type="checkbox"/> Masterplan	○●●●●●●● 1-7	○ Points	Number of Credits – HQM 11.3	●●●●●●●● 1 <span style="float:right">8</span> ✓ 3	6 ★
HPB20	Smart Building Technologies – Commercial	Calculates the number of relevant smart building technologies used in a building	<input type="checkbox"/> Residential <input checked="" type="checkbox"/> Commercial <input checked="" type="checkbox"/> Masterplan	○●●●●●●● 1-7	% Percentage	Percentage of Applicable Smart Ready Services Incorporated	0 <span style="float:right">100%</span> 	100% ✓ ★
HPB21	Responsible Construction Practices – Residential	Promotes environmentally and socially considerate and accountable management of construction sites in residential schemes	<input checked="" type="checkbox"/> Residential <input type="checkbox"/> Commercial <input checked="" type="checkbox"/> Masterplan	○●●●●●●● 1-7	○ Points	Number of Credits – HQM 10.1 + 10.2 + 10.3	●●●●●●●● 1 <span style="float:right">15</span> 10 ✓	15 ★
HPB22	Responsible Construction Practices – Commercial	Promotes environmentally and socially considerate and accountable management of construction sites in residential schemes	<input type="checkbox"/> Residential <input checked="" type="checkbox"/> Commercial <input checked="" type="checkbox"/> Masterplan	○●●●●●●● 1-7	○ Points	Number of Credits – BREEAM Man 03	●●●●●●●● 1 <span style="float:right">7</span> ✓ 4	7 ★

ID	Indicator	What it does	Applies to	RIBA Stages	Metric	Unit	Range	✓ Good practice ★ Leading practice
HPB 23	Construction Waste – Residential	Encourages environmentally responsible management of construction waste	<input checked="" type="checkbox"/> Residential <input type="checkbox"/> Commercial <input checked="" type="checkbox"/> Masterplan	 1-7	 Points	Number of Credits – HQM 10.4	 1 ✓ 10 16	16 ★
HPB 24	Construction Waste – Commercial	Encourages environmentally responsible management of construction waste	<input type="checkbox"/> Residential <input checked="" type="checkbox"/> Commercial <input checked="" type="checkbox"/> Masterplan	 1-7	 Points	Number of Credits – BREEAM Wst 01	 1 ✓ 4 7	7 ★
HPB 25	Operational Recycling and Composting – Residential	Aims to reduce the amount of domestic waste going to landfill by ensuring suitable areas for residents to dispose of recyclable waste	<input checked="" type="checkbox"/> Residential <input type="checkbox"/> Commercial <input checked="" type="checkbox"/> Masterplan	 1-7	 Points	Number of Credits – HQM 7.3	 1 ✓ 7 10	10 ★
HPB 26	Operational Recycling and Composting – Commercial	Aims to reduce the amount of commercial waste going to landfill by ensuring suitable areas for occupants to dispose of recyclable waste	<input type="checkbox"/> Residential <input checked="" type="checkbox"/> Commercial <input checked="" type="checkbox"/> Masterplan	 1-7	 Points	Number of Credits – BREEAM Wst 03	 1 ✓ ★ 1	1 ★
HPB 27	Post Occupancy Evaluation – Residential	Evaluates performance of homes once occupied, and the everyday experience of residents	<input checked="" type="checkbox"/> Residential <input type="checkbox"/> Commercial <input type="checkbox"/> Masterplan	 1-7	 Points	Number of Credits – HQM 11.4	 1 ✓ 5 10	10 ★
HPB 28	Post Occupancy Evaluation – Commercial	Evaluates experience of occupants once the building is completed, including any support given	<input type="checkbox"/> Residential <input checked="" type="checkbox"/> Commercial <input type="checkbox"/> Masterplan	 1-7	 Points	Number of Credits – BREEAM Man 05	 1 ✓ 2 3	3 ★
HPB 29	Sustainable Operations Management	Aims to ensure buildings perform as intended in operation, and that deficiencies are resolved where feasible	<input type="checkbox"/> Residential <input checked="" type="checkbox"/> Commercial <input type="checkbox"/> Masterplan	 5-7	 Practices	Number of practices met	 1 ✓ 2 4	4 ★

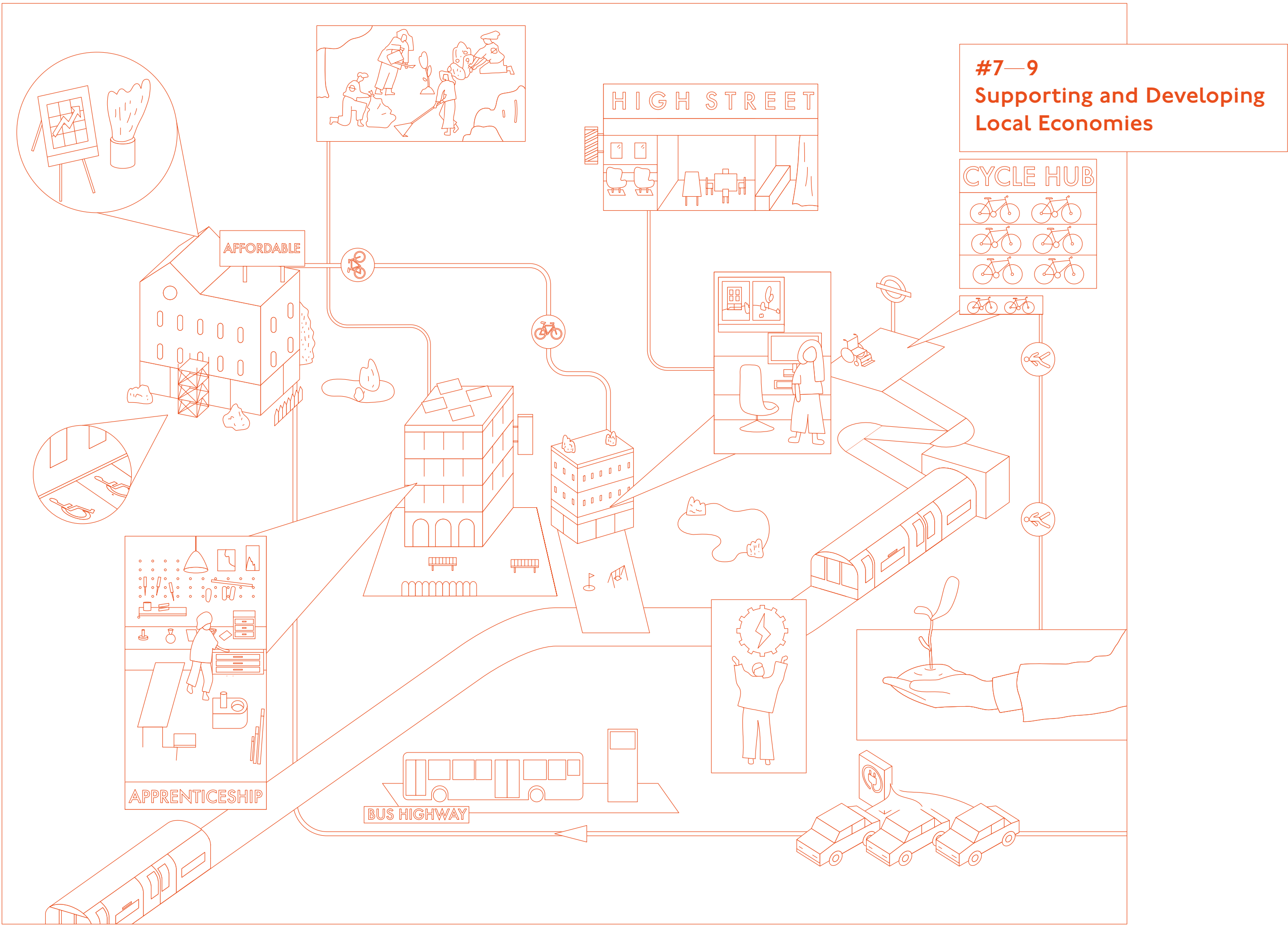

**#7—9**  
**Supporting and Developing**  
**Local Economies**

CYCLE HUB

Icon of a person in a wheelchair.

APPRENTICESHIP

BUS HIGHWAY

HIGH STREET



## Dimension #7 Financial Sustainability [FS]

Financial Sustainability is about recognising that, if considered holistically, financial returns and sustainability can go hand in hand. By making this explicit in the SDF, we can understand and embed the commercial implications of being more sustainable, and open up the conversation around sustainability in the broadest sense.

It is also one of our core objectives to provide a steady, increasing and sustainable stream of revenue that can be invested in London’s transport network, improving it for the benefit of all Londoners.

In line with this thinking, we have developed a set of Indicators that both acknowledge the need for financial returns and help us mobilise sustainability as a means of enhancing them.

They include:

- Use of Green Finance to reduce the cost of capital;
- Deployment of Green Leases to capture sustainability-related operational benefits; and
- Capturing the financial implications of sustainability – positive and negative – in our financial appraisals and decision-making and capital allocation.

Applying these Indicators allows us to understand the impact of sustainable measures on our financial returns. With this knowledge we are able to maximise the overall performance of projects while ensuring they remain viable, and deliver more robust financial returns for investment in London’s transport system.

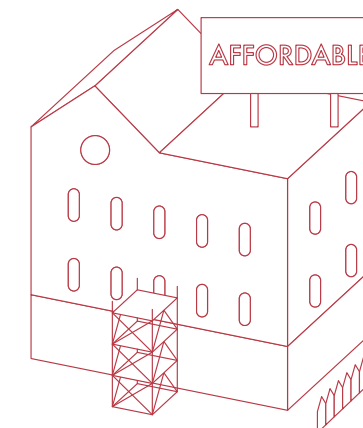
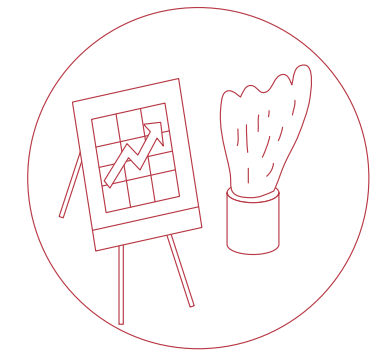
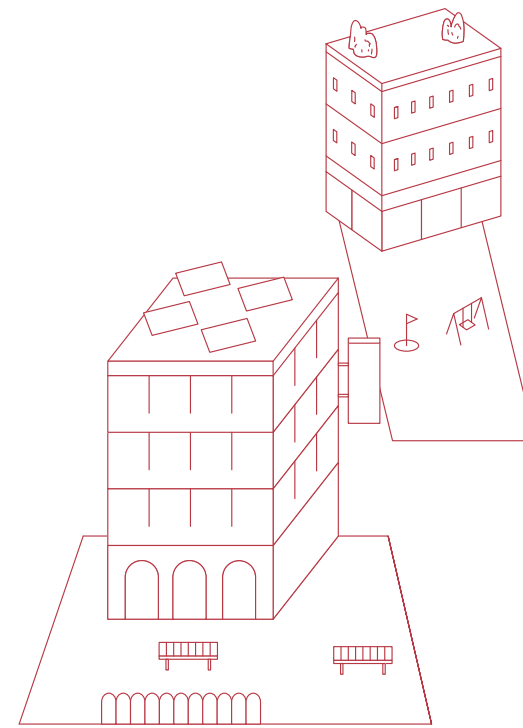



## Financial Sustainability Indicators

ID	Indicator	What it does	Applies to	RIBA Stages	Metric	Unit	Range	<input checked="" type="checkbox"/> Good practice <input checked="" type="checkbox"/> Leading practice
FS1	Internal Rate of Return	Measures the return on investment achieved by a development project and the associated financial benefit to TfL	<input checked="" type="checkbox"/> Residential <input checked="" type="checkbox"/> Commercial <input checked="" type="checkbox"/> Masterplan	 0–7	% Percentage	Percentage of IRR	Confidential	
FS2	Return on Equity	Measures the return on investment achieved by a development project and the associated financial benefit to TfL	<input checked="" type="checkbox"/> Residential <input checked="" type="checkbox"/> Commercial <input checked="" type="checkbox"/> Masterplan	 0–7	% Percentage	Percentage of return on equity	Confidential	
FS3	Green Finance	Encourages the uptake of green debt, which may lead to preferential rates or terms	<input checked="" type="checkbox"/> Residential <input checked="" type="checkbox"/> Commercial <input checked="" type="checkbox"/> Masterplan	 3–5	% Percentage	Percentage of overall project debt	 0 ✓ 20% 100%	100% ★
FS4	Green Leases	Encourages sustainable tenant behaviour and allows the landlord / developer to generate a return on their investment in enhanced energy efficiency	<input type="checkbox"/> Residential <input checked="" type="checkbox"/> Commercial <input type="checkbox"/> Masterplan	 5–7	% Percentage	Percentage of rent roll that is on a green lease	 0 ✓ 40% 100%	100% ★
FS5	Hypothecated Value to TfL	Captures and illustrates the financial value provided to TfL (and where relevant, the wider community) by the project	<input checked="" type="checkbox"/> Residential <input checked="" type="checkbox"/> Commercial <input checked="" type="checkbox"/> Masterplan	 0–7	£ Financial	Hypothecated value in pounds	Reporting	

**Dimension #8**  
**Local Prosperity [LP]**

The Local Prosperity Dimension looks at ways that projects can create economic opportunities for all of London – from small businesses and start-ups to cultural organisations and creative industry. Ultimately this should increase prosperity at a local level, supporting successful high streets, better local amenities, and more attractive public realm.

Promoting economic opportunity and growth is critical in building a better London. To us, the prosperity created through development needs to be shared by local communities; viewed holistically (see Dimension #7), this helps us build a more sustainable, resilient, and high-performance business.

In line with this philosophy, the Local Prosperity Dimension contains a wide range of Indicators that target and reinforce a project’s contribution to the economic health of London’s communities.

It contains Indicators that:

- Facilitate routes to skilled employment for all Londoners, regardless of background, ethnicity, gender, ability, or other protected characteristics;
- Yield long-term and high-quality job prospects for local people that are fair and inclusive;
- Create a home for businesses and organisations that struggle to find affordable space in London;
- Support the resilience and growth of local businesses, SMEs, entrepreneurs, social enterprise, and creative industry;

In developing and applying these Indicators, our projects can drive inclusive economic growth in local neighbourhoods. The end result: a London that is more equitable, resilient, and prosperous for all.

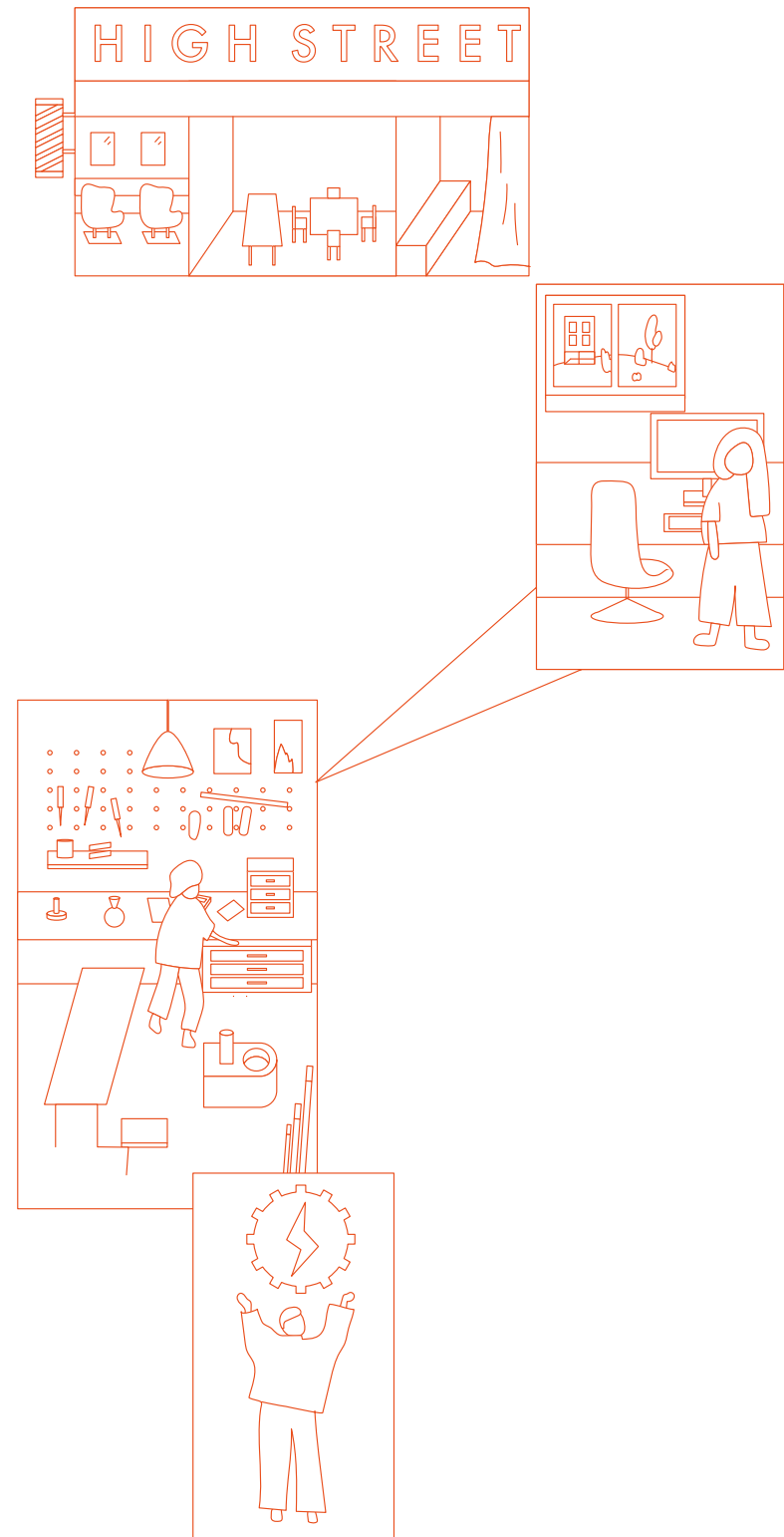





## Local Prosperity Indicators

ID	Indicator	What it does	Applies to	RIBA Stages	Metric	Unit	Range	✓ Good practice ★ Leading practice
LP1	Apprenticeships	Encourages recruitment of traditional apprentices, degree apprentices or shared apprentices to the project workforce	<input checked="" type="checkbox"/> Residential <input checked="" type="checkbox"/> Commercial <input checked="" type="checkbox"/> Masterplan	○○●●●●○ 2–6	# Numerical	No. of apprenticeships by contract value	0 ✓ > In line with industry benchmarks	★ Good + 10%
LP2	Apprenticeship Diversity – Disabilities	Measures the level of diversity in the workforce that is trained through a project’s apprenticeship programmes	<input checked="" type="checkbox"/> Residential <input checked="" type="checkbox"/> Commercial <input checked="" type="checkbox"/> Masterplan	○○○●●●○ 3–6	% Percentage	Percentage representation of key under-represented groups	✓ 5% 100%	★ 10%
LP3	Apprenticeship Diversity – Gender	Encourages greater representation of women on any apprenticeship schemes	<input checked="" type="checkbox"/> Residential <input checked="" type="checkbox"/> Commercial <input checked="" type="checkbox"/> Masterplan	○○○●●●○ 3–6	% Percentage	Percentage representation of key under-represented groups	0 ✓ 20% 100%	★ 30%
LP4	Apprenticeship Diversity – Ethnicity	Encourages greater representation of ethnic minority groups on any apprenticeship schemes	<input checked="" type="checkbox"/> Residential <input checked="" type="checkbox"/> Commercial <input checked="" type="checkbox"/> Masterplan	○○○●●●○ 3–6	% Percentage	Percentage representation of key under-represented groups	0 ✓ 30% 100%	★ 40%
LP5	Work Placements	Calculates number of meaningful work experience opportunities created	<input checked="" type="checkbox"/> Residential <input checked="" type="checkbox"/> Commercial <input checked="" type="checkbox"/> Masterplan	○○○●●●○ 3–6	# Numerical	No. of work placements by contract value	0 ✓ > In line with industry benchmarks	★ Good + 10%
LP6	Local Jobs Created during Construction	Calculates number of new and sustainable jobs created locally during construction	<input checked="" type="checkbox"/> Residential <input checked="" type="checkbox"/> Commercial <input checked="" type="checkbox"/> Masterplan	○○○●●●○ 3–6	# Numerical	No. of local jobs created by contract value	0 ✓ > In line with industry benchmarks	★ Good + 10%
LP7	Supporting Local Commerce	Provides business support to local commerce	<input type="checkbox"/> Residential <input checked="" type="checkbox"/> Commercial <input checked="" type="checkbox"/> Masterplan	●●●○●●●● 0–2, 4–7	○ Points	No. of support measures	1 ✓ 2 ● 4+	4 ★ 4+

ID	Indicator	What it does	Applies to	RIBA Stages	Metric	Unit	Range	✓ Good practice ★ Leading practice
LP8	Supporting SMEs and Social Enterprise	Provides workspace for local start-ups, SMEs and social enterprise	<input type="checkbox"/> Residential <input checked="" type="checkbox"/> Commercial <input checked="" type="checkbox"/> Masterplan	● ○ ● ○ ○ ● ● ● 0, 2, 5-7	○ Points	Type of provision	● ✓ 1	2 ★ ● 2
LP9	Supporting Creativity and Culture	Includes workspace for creative and cultural production and consumption	<input type="checkbox"/> Residential <input checked="" type="checkbox"/> Commercial <input checked="" type="checkbox"/> Masterplan	○ ○ ● ● ● ● ● ● 2-7	○ Points	Measures in place	● ✓ 1	2 ★ ● 2
LP10	Fair Employment Practices	Measures the proportion of organisations procured throughout the development process who have fair and inclusive employment and workplace development practices in place	<input checked="" type="checkbox"/> Residential <input checked="" type="checkbox"/> Commercial <input checked="" type="checkbox"/> Masterplan	○ ● ○ ○ ● ● ○ ● 1, 4-5, 7	★ Foundation Achievement Excellence	GLA Good Work Standard	✓ Foundation ★ Excellence	



## Dimension #9 Neighbourhood Investment [NI]

Through this Dimension we can use property development as a catalyst for making London’s neighbourhoods more environmentally, socially, and economically sustainable.

We are already in a strong position to build on our legacy of investing in better and more sustainable transport. At the same time, projects can invest in neighbourhoods in many more ways; this Dimension seeks to ensure that these investments have a wide impact in the areas of everyday life where it is needed most. This could mean investing in cycle hubs, electric car clubs, step-free access to stations, or encouraging active travel and healthy lifestyles.

To that end, the Neighbourhood Investment Dimension contains Indicators that help to:

- Support car-free living or the transition to electric vehicles;
- Direct investment to suitable transport network upgrades, including accessibility;
- Deliver improvements to cycling and pedestrian infrastructure;

The application of these Indicators helps us direct investment in a way that genuinely contributes to London’s neighbourhoods, directing funds to the right places, for the right purposes. Through this Dimension we are able to respond to local opportunities and deliver maximum impact for London.

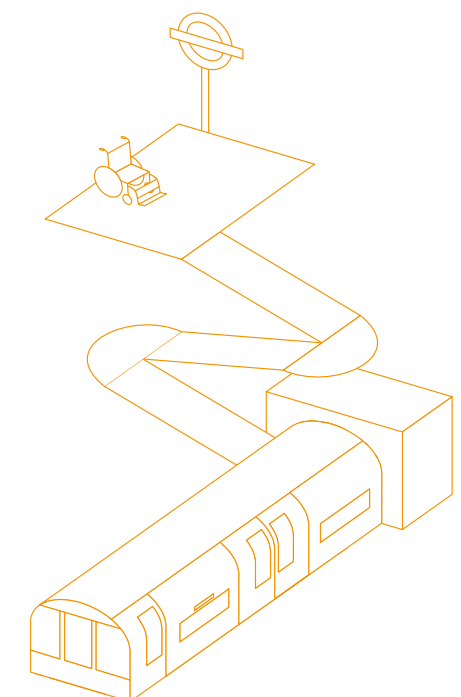
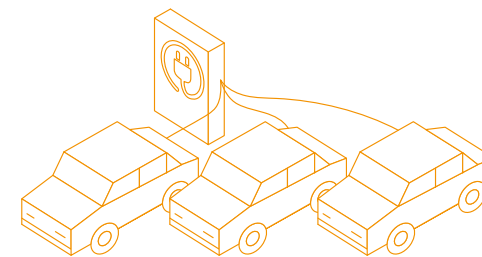
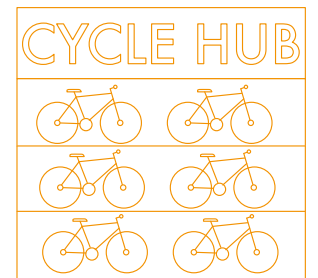
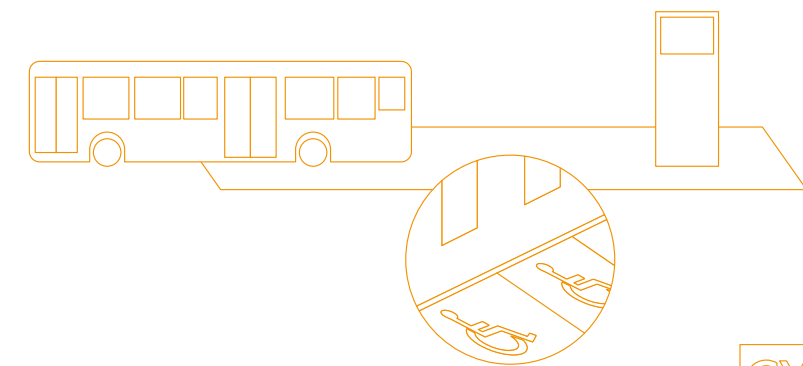
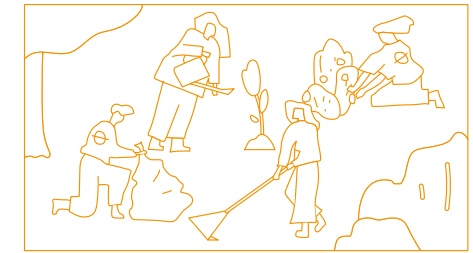



## Neighbourhood Investment Indicators

ID	Indicator	What it does	Applies to	RIBA Stages	Metric	Unit	Range	✓ Good practice ★ Leading practice
NI1	Investment in TfL Transport Infrastructure	Assesses whether new development will generate investment in London Underground and Surface infrastructure	<input checked="" type="checkbox"/> Residential <input checked="" type="checkbox"/> Commercial <input checked="" type="checkbox"/> Masterplan	●●●○●○●○ 0–2, 4, 6	 Impact	Impact on LUL & Surface Infrastructure	✓ Mitigation ★ Improvement	
NI2	Active Travel Transport Infrastructure	Assesses whether new development will generate investment into active travel infrastructure	<input checked="" type="checkbox"/> Residential <input checked="" type="checkbox"/> Commercial <input checked="" type="checkbox"/> Masterplan	●●●○●○●○ 0–2, 4, 6	 Impact	Impact on Active Travel Infrastructure	✓ Mitigation ★ Improvement	
NI3	Station Cycle Parking Provision	Encourages provision of cycle parking at stations	<input checked="" type="checkbox"/> Residential <input checked="" type="checkbox"/> Commercial <input checked="" type="checkbox"/> Masterplan	○●●○○○○●○ 1–2, 6	 Type	Type of provision	✓ On-street cycle parking ★ Secure Cycle Hubs	
NI4	Electric Vehicle (EV) Charging	Encourages provision of Electric Vehicle (EV) charging	<input checked="" type="checkbox"/> Residential <input checked="" type="checkbox"/> Commercial <input checked="" type="checkbox"/> Masterplan	○●●●●●○○○ 1–5	% Percentage	Percentage of spaces with an active provision	0  100% ★ ✓ 20%	
NI5	Electric Car Share	Encourages provision of car parking spaces dedicated to (electric) car club providers for use by residents	<input checked="" type="checkbox"/> Residential <input type="checkbox"/> Commercial <input checked="" type="checkbox"/> Masterplan	○●●○○●●●○ 1–2, 4–6	# Numerical	Number of spaces	✓ 1 electric car club space for residents ★ Good + provision for ECCS for local community based on demand identified by car club provider	
NI6	Car Free Living	Discourages general car parking provision, with the exception of Blue Badge spaces	<input checked="" type="checkbox"/> Residential <input type="checkbox"/> Commercial <input checked="" type="checkbox"/> Masterplan	○●●○○●○○○ 1–2, 4, 6	# Numerical	Car parking spaces per unit	✓ London Plan Standard ★ Car Free Development	
NI7	Blue Badge Spaces	Designates the number of Blue Badge spaces needed	<input checked="" type="checkbox"/> Residential <input checked="" type="checkbox"/> Commercial <input checked="" type="checkbox"/> Masterplan	○●●○○○○●○ 1–2, 6	✓ ✗ Pass / Fail	Number of Blue Badge parking spaces	✓ ★ London Plan Standard or existing blue badge spaces	
NI8	Community Initiatives Grants	Encourages grants for new and existing community initiatives that benefit the neighbourhood	<input checked="" type="checkbox"/> Residential <input checked="" type="checkbox"/> Commercial <input checked="" type="checkbox"/> Masterplan	○●●○○○○●○ 1–2, 6	£ Financial	£ invested for every £10,000 of GDV	0  > ★ £2+ ✓ £1	
NI9	Community Volunteering (R)	Measures proportion of staff hours dedicated to volunteering	<input checked="" type="checkbox"/> Residential <input checked="" type="checkbox"/> Commercial <input checked="" type="checkbox"/> Masterplan	○●●○○○○●○ 1–2, 6	 Hours	Hours per project	Reporting	

Part 2

# The Sustainable Development Framework in Action

Part 2 of the Handbook looks more closely at the management and delivery of the SDF, showing how the Indicators can be used in parallel with the RIBA Stages of Work. It helps those who will be managing projects understand how the SDF can deliver more sustainable outcomes.

More detailed information on the individual Indicators is currently being refined into Technical Guidance documents that will accompany this Handbook.

These documents will include an overview of the Indicator, the ways in which it adds value to a project, and a methodology that explains how it is calculated. Alongside this will be a step by step guide showing how to implement the Indicator through the RIBA Work Stages. Finally there will be links to further reading and policy resources.

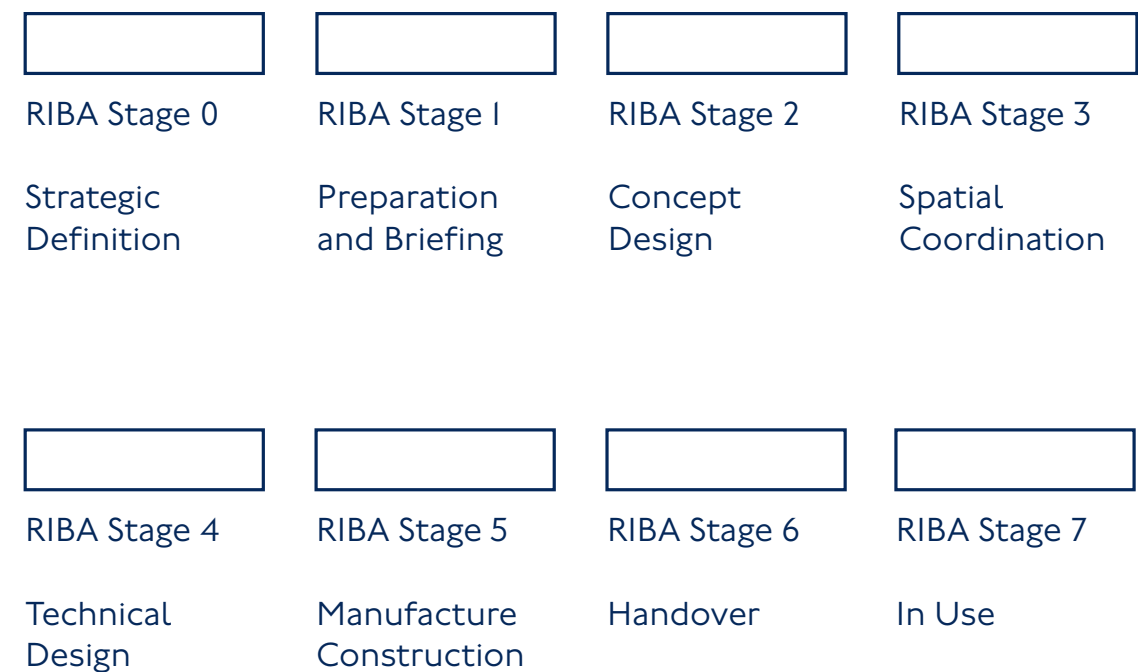

## How the Indicators Work

The SDF contains approximately 100 Indicators spanning all nine Dimensions of sustainability. These Indicators vary in type, to be selected from according to the nature of the development (eg commercial or residential).

Throughout the lifecycle of a project, performance data for relevant Indicators – projected or actual – should be collected and recorded. The raw data is entered into an SDF scorecard system, where it is translated into informative, comparable and reportable scores.

Each Indicator is scored out of 100, where 50 is 'Good Practice', and 100 is considered 'Leading Practice'.

By referring to these scores, and comparing them to our Good Practice and Leading Practice benchmarks, managers can see at a glance how well a project is performing. They will be able to tell a project's strengths and weaknesses and identify opportunities for improvement.

This data should be collected regularly so that decisions can be made based on their impact across the whole Framework.

Scores can also help to:

- Clarify how certain strategies or interventions impact the project's overall sustainability;
- Identify cases where improving or reducing the performance of one Indicator affects the performance of another.

In general, we estimate that a single project would monitor 60-80 Indicators during its lifetime.

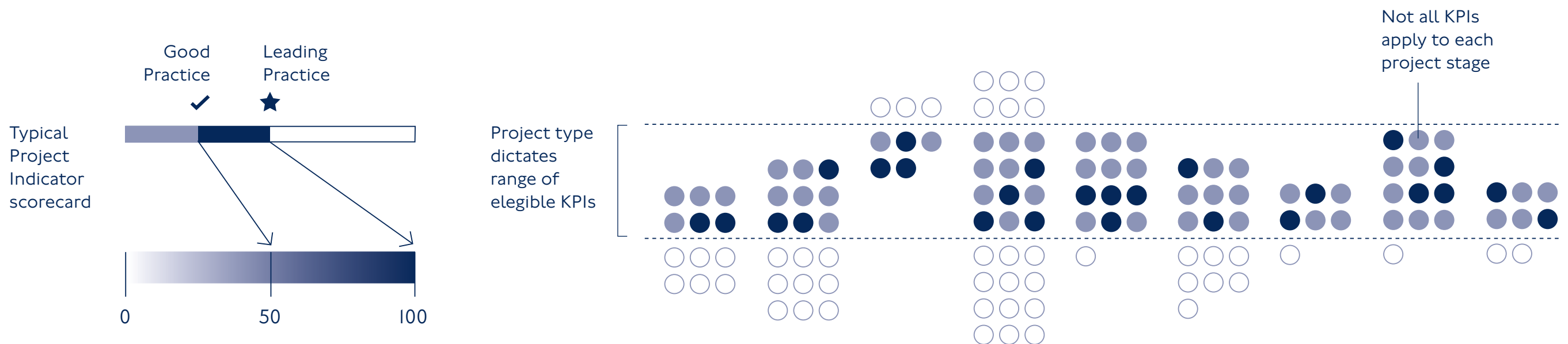

## Applying the Indicators

As a development progresses through the RIBA Stages of Work, different sorts of activities will be required, feeding into each other.

What these activities are, what data they need to input, the expected outputs and at what RIBA Stage these should take place are all illustrated over the coming pages.

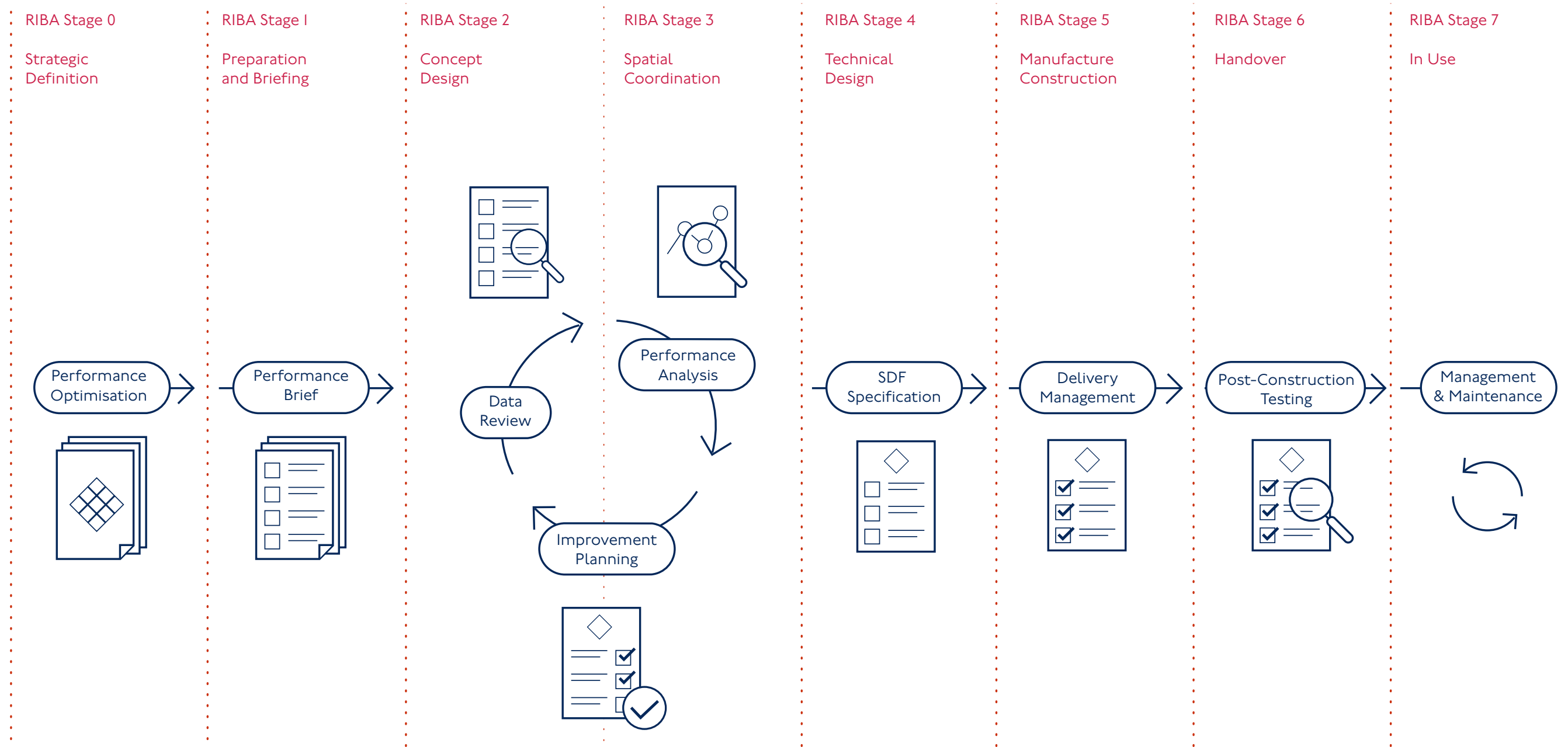



# Performance Optimisation

At RIBA Stages 0 and I, the primary activity is the production of an Optimisation Brief covering each of the nine Dimensions (set out on pages 16–44). The aim is to gain an understanding of the opportunities and constraints of a site and use them to help develop a context-specific roadmap that optimises sustainability.

Use the Framework to help identify and adjust strategies, interventions and design tactics that will deliver the best overall outcome balanced across the nine Dimensions.

**When:**

- At RIBA Stages 0-I
- Useful to include in procurement exercises for consultants and/or development partners

**Benefits:**

- Sustainability performance is optimised in a way that is commercially viable
- SMART outcomes defined for the design team

RIBA Stage 0 Strategic Definition



**Input:**

Instruction to proceed

**Main function:**

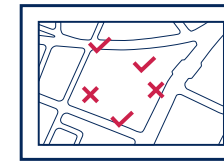

Assess the site for sustainability-related opportunities and challenges



Identify applicable indicators and set out relevant policy and local context

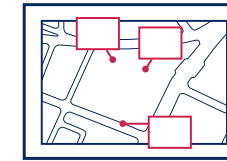

Undertake relevant baselining exercises

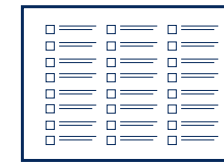

Develop a series of principles for site-specific implementation of the SDF

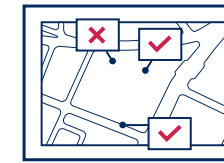

Identify 'Good Practices' and 'Leading Practices' to delivering against indicator targets

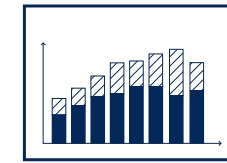

Complete a high-level cost benefit analysis to test the feasibility of these practices



Set the sustainability brief for the incoming project team with clear actions and objectives

**Output:**

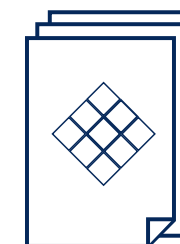

An Optimisation Brief (covering all Dimensions)

# Performance Brief

At the next stage, the project team should review the Optimisation Brief and translate this into a clear Performance Brief, which could include a Project Sustainability Charter and a Project Scorecard Template.

The viability of the Optimisation Brief should be considered alongside the priorities of the local community and any relevant local planning policy or planning officer input. Key priorities can then be set for the project and the relevant Indicators identified. The project vision for delivering the SDF can be drawn up, though this may be amended as the project progresses and improvements are identified.

When:

- Once the Optimisation Brief has been created and the project team appointed, usually during RIBA Stage I

Benefits:

- Establishes ambitious yet feasible targets
- Clarifies ambitions, priorities and objectives for the project team

RIBA Stage I Preparation and Briefing

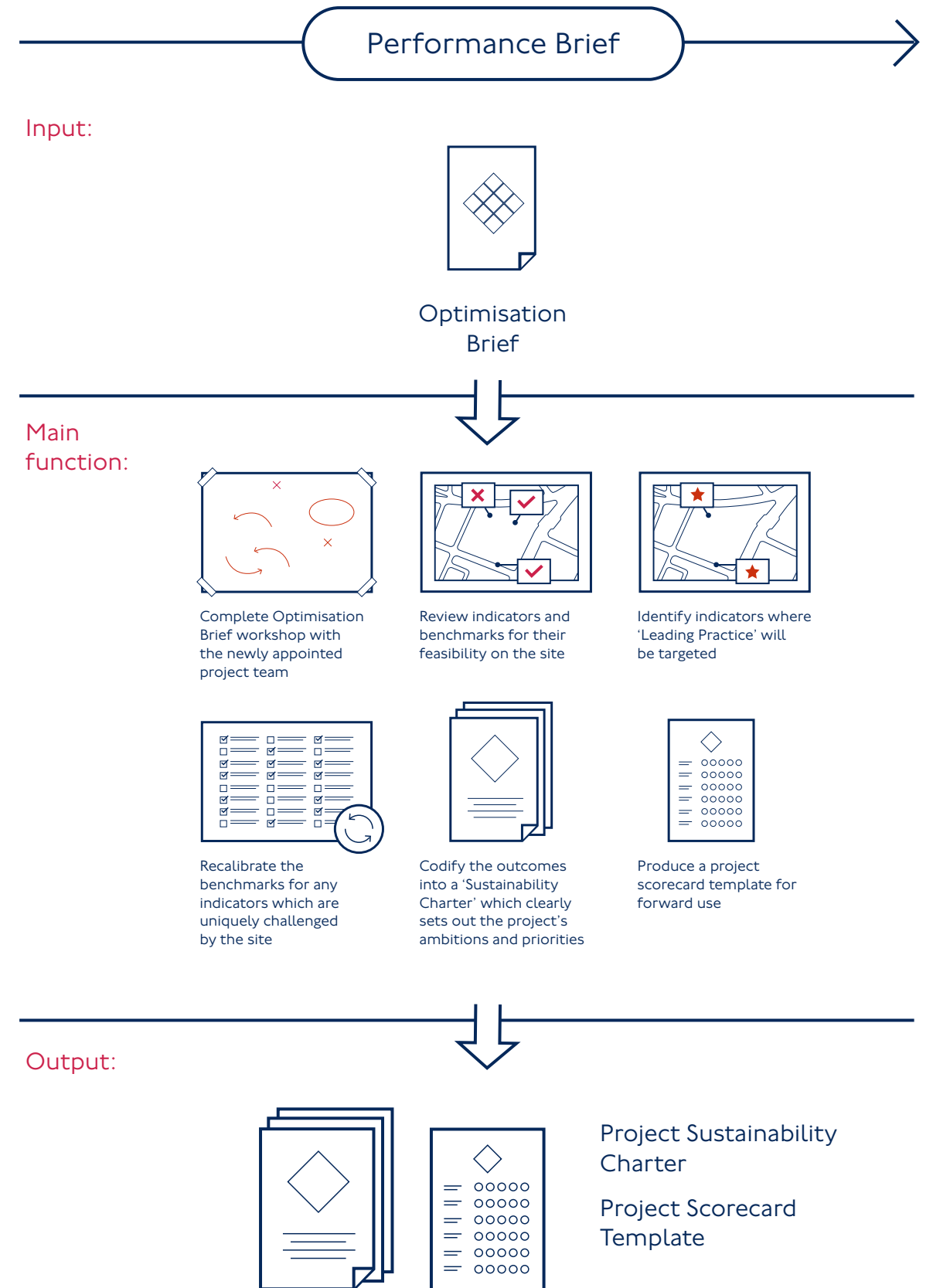

## Ongoing Performance Improvement

Leading up to a planning application, and through detailed design, a cycle of activities works iteratively to keep reviewing and improving the project's performance.

### a) Data review

First, project performance data will be collected from specialist consultants by the SDF analyst and entered into a central database.

### b) Performance analysis

The resulting Project Scorecard becomes a visual performance dashboard, which can be analysed to highlight areas of excellence and underperformance. Indicators requiring improvement are logged in an Action Tracker.

### c) Improvement planning

The overall project dashboard and the SDF Action Tracker shape an Improvement Plan. Key recommendations are identified and responsibilities assigned for actions to be taken over the following four weeks.

The process is repeated each month as improvements are made and then re-assessed. After several successive iterations, a Project Action Plan will begin to take shape.

### When:

- Every four weeks, from RIBA Stage 2 to RIBA Stage 4
- May continue with a light touch until RIBA Stage 6 to incorporate Indicators that apply to later project stages

### Benefits:

- Data collection quantifies, captures and centralises the project's sustainability performance data
- Scores can be further analysed, investigated and improved
- Areas of excellence can be identified and publicised
- Dashboards provide insight for benchmarking and governance

## RIBA Stage 2 & 3 Concept Design & Spatial Coordination

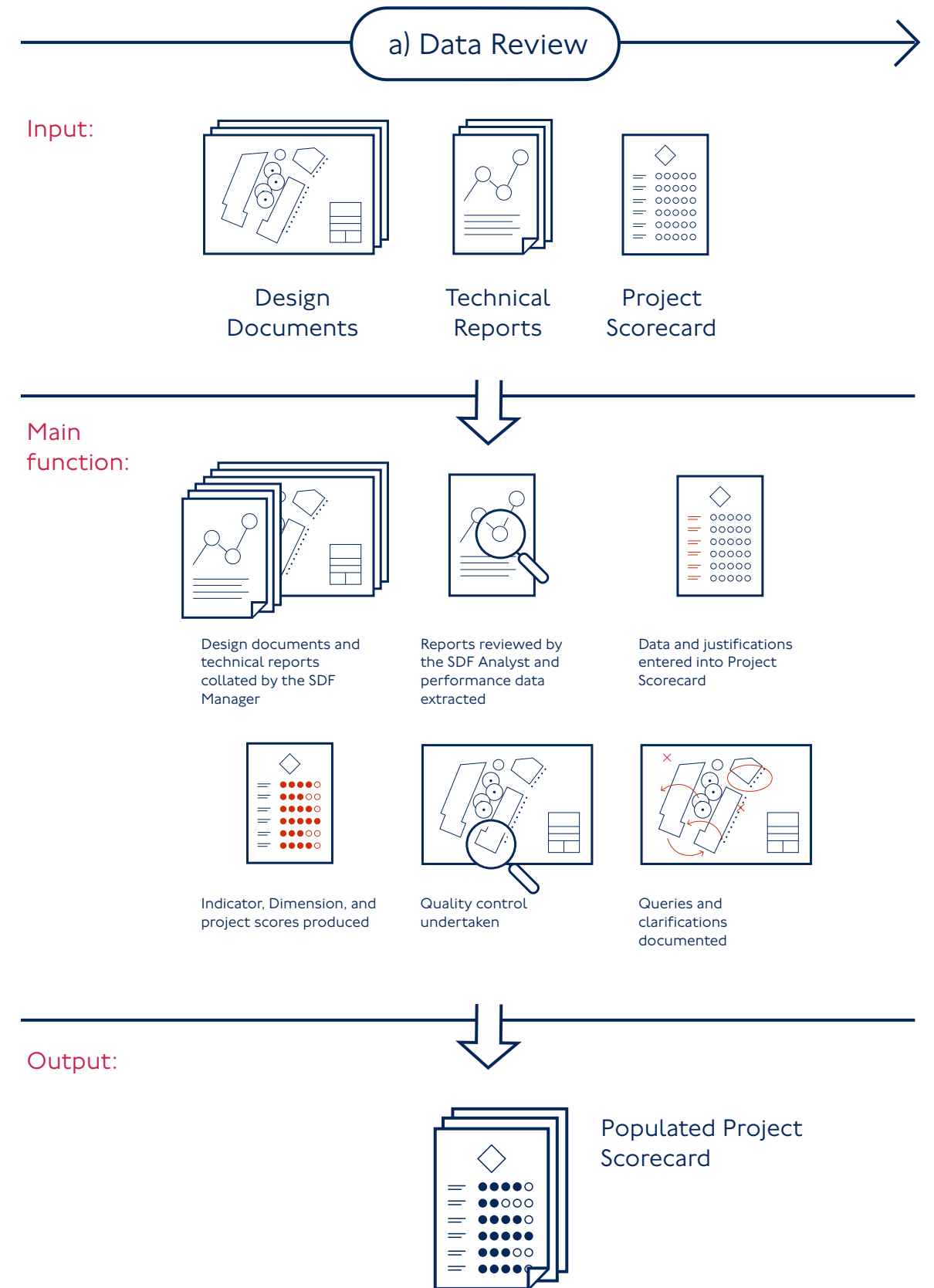

RIBA Stage 2 & 3 Concept Design & Spatial Coordination

b) Performance Analysis

Input:



Project Scorecard

Main function:

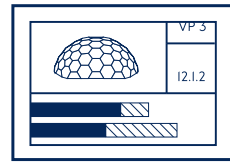

Data and scores converted into dashboards



Analysis to identify areas of excellence and associated messaging

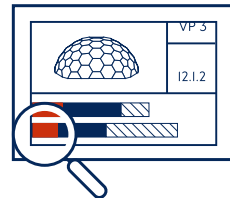

Analysis to identify areas of underperformance and any critical failures

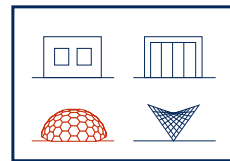

Comparison of project performance to industry standards and other TfL projects



Reports to leadership and governance groups

Output:

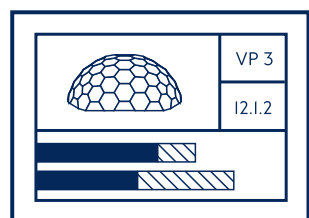

Project SDF Dashboard

RIBA Stage 2 & 3 Concept Design & Spatial Coordination

c) Improvement Planning

Input:

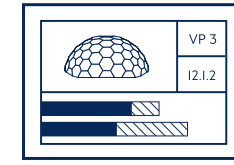

Project SDF Dashboard



SDF Action Tracker

Main function:

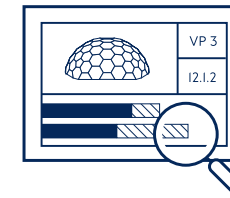

Review outputs of performance analysis and select indicators for further assessment



Undertake options appraisal to identify strategies for improving performance



Set out recommended strategies and associated actions for consideration by the project team

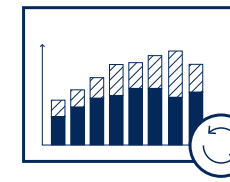

Set out costs, benefits, and projected performance for recommendations



Project team to review and agree strategies and actions to be taken forward

Output:



Project SDF Action Plan

# Sustainable Development Framework Tender Checklist

As part of the preparation of tender documentation for selecting a contractor, a checklist of all of the relevant Indicators should be embedded into the Invitations to Tender (ITTs) and the employer's requirements.

**When:**

- During the detailed design stages after planning approval has been gained
- Feeds into procurement documents for contractors and construction delivery partners

**Benefits:**

- Sets clear requirements on sustainability performance and reporting for the supply chain
- Encodes the SDF into procurements and contracts
- Bidders can be scored on their ability to help deliver the SDF

RIBA Stage 4 Technical Design

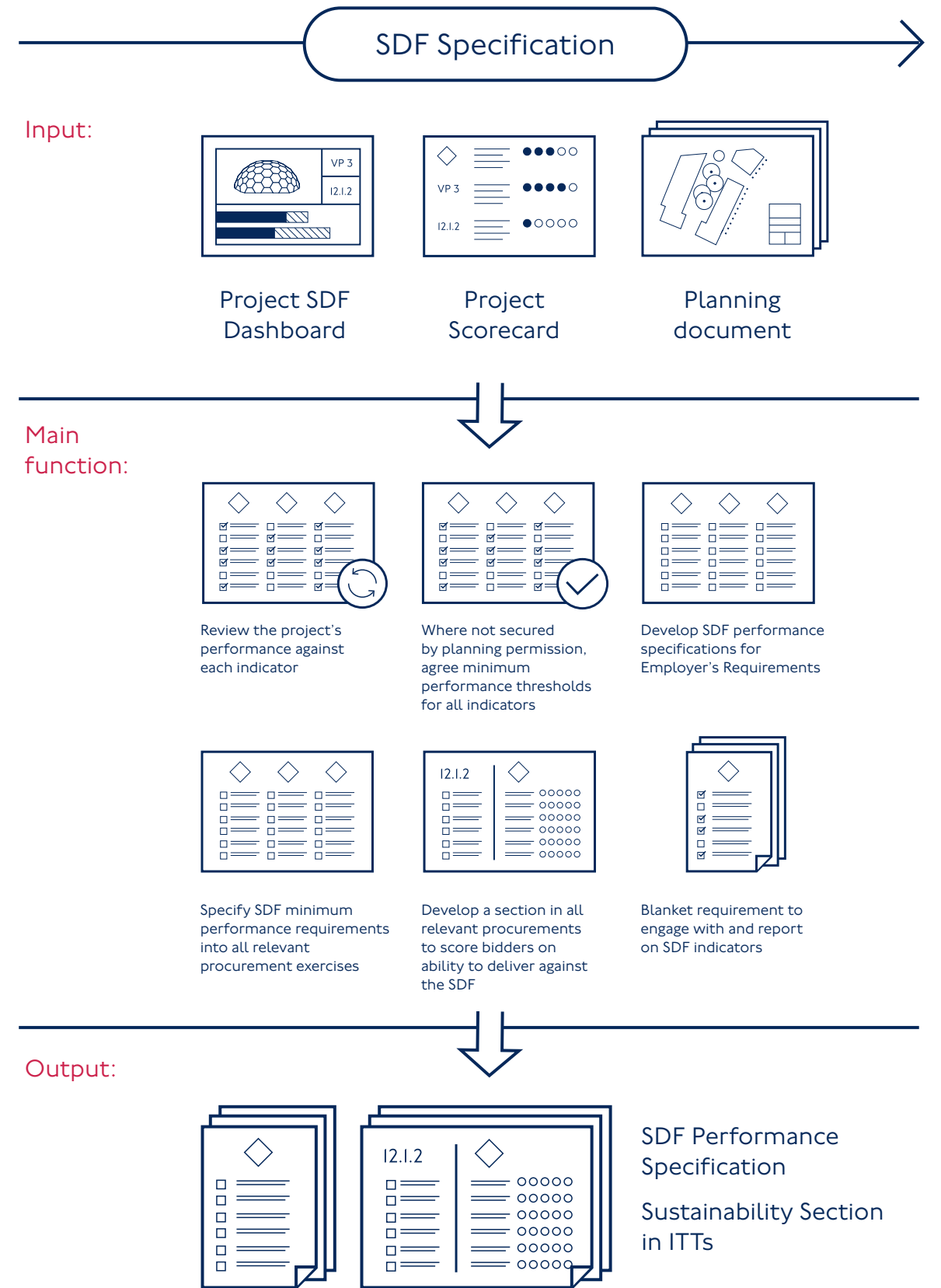

## Delivery Management

Throughout the Construction Stage of a project there is a quality control process to ensure the Project Specification that has been drawn up during previous Stages is delivered in practice. This should be done in partnership with the contractor team so that a Construction Scorecard can be produced. A range of quality control measures will help minimise the gap between design intent and performance.

**When:**

- Site visits and progress meetings are a good time to include performance monitoring for all Indicators during RIBA Stage 5

**Benefits:**

- Ensures intended performance is achieved on site
- Provides detailed monitoring of contractor performance against construction-related indicators

RIBA Stage 5 Manufacturing and Construction

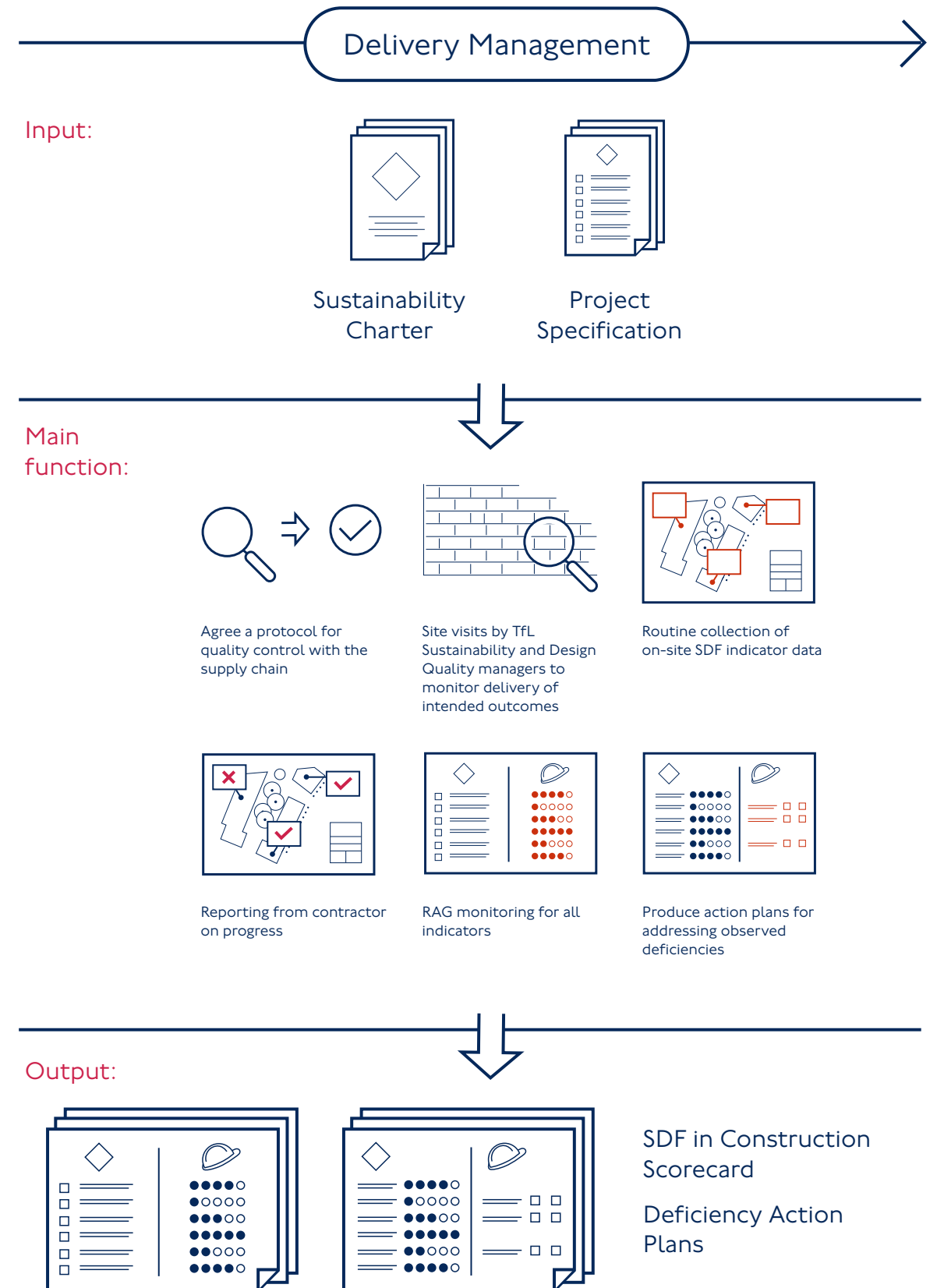

## Post-construction Testing

As the Building Contract is concluded, post-construction testing is carried out. The finished development is scored against the Indicator performance agreed in the contract. A performance gap report is produced and, if necessary, remedial work is undertaken to address any deficiencies. A In-Occupancy plan is also produced to guide continued sustainability performance once the building is in use.

When:

- As part of the handover process during RIBA Stage 6

Benefits:

- Minimises the performance gap where possible
- Provides valuable data about the feasibility of achieving the design intent
- Establishes a protocol for embedding the SDF into the operation of the development

RIBA Stage 6 Handover

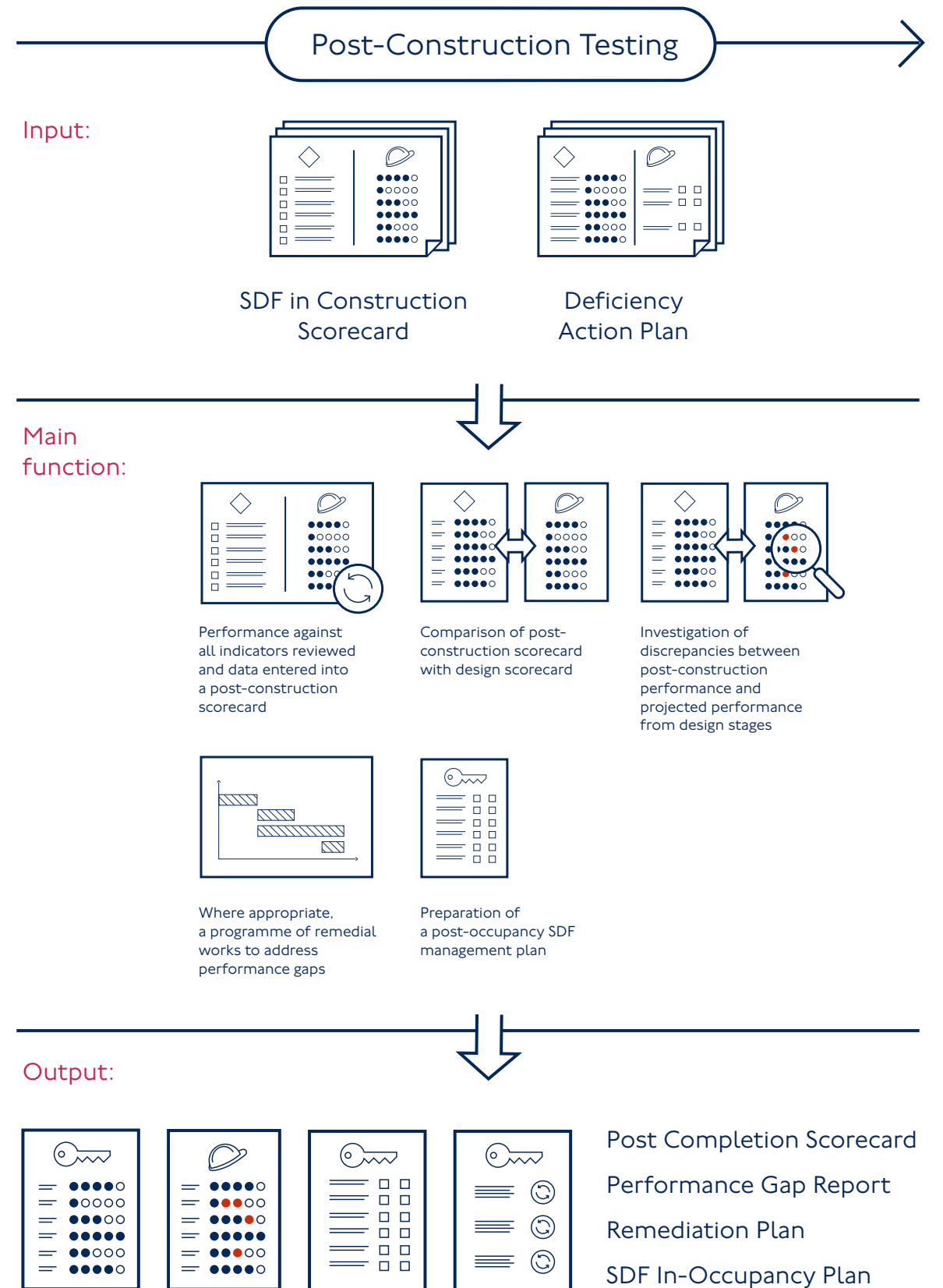

## Management and Maintenance

For a scheme to be truly sustainable, it is essential that the SDF Indicators are upheld not just in the design and construction of a development, but once it is in use. A Stakeholder Engagement Plan and Maintenance Programme are recommended. Periodically the operational performance of a building will need to be assessed to ensure targets are maintained or improved upon.

Through this process, the holistic principles of sustainable development underpinning the Framework are implemented throughout the operational life of a project.

**When:**

- Throughout the lifetime of the building

**Benefits:**

- Lessons can be learned from performance gaps
- Valuable benchmark data can be collected
- Stakeholders are able to maintain and improve the project's sustainability performance

RIBA Stage 7 In Use

### SDF Management and Maintenance

Input:

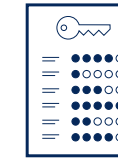

SDF In-Occupancy Plan

Post-Completion Scorecard

Main function:

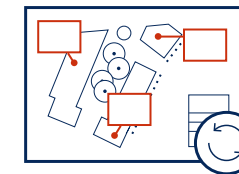

Periodic collection and reporting of in-use performance data for relevant SDF indicators

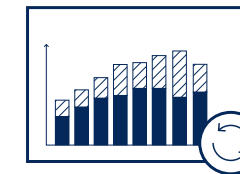

Trend analysis considering changes in performance over time

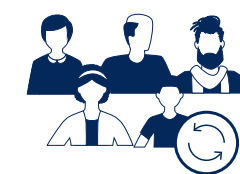

Engagement with stakeholders (e.g. tenants, managing agents) to promote sustainable operations



Analysis of performance to identify opportunities for in-use optimisation

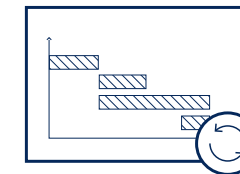

Develop maintenance programme to avoid deterioration in performance

Output:

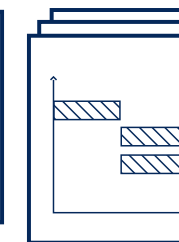

Operational Performance Report

Stakeholder Engagement Plan

Maintenance Programme



# Summary

This Handbook has given an overview of how the SDF can be used to push developments to optimise their sustainability. It does this by respecting our five overarching principles (page 7) of building a better London, delivering real results, thinking long term, taking a holistic view and responding to local context.

The strength of the SDF is its ability to find synergies that would ordinarily go unseen or opportunities that could otherwise be overlooked. It does this by giving projects the tools to measure and balance performance across all facets of sustainability and throughout every stage of its delivery. To make the most of this, we recommend that the Framework should be built into a project as early as possible.

Our intention is that this Handbook and the forthcoming technical guidance be an open source document to be accessed and used by anyone. We are looking forward to all of our partners across the industry being able to own and continue to help us develop this Framework.

The SDF will constantly evolve and improve in line with experience, policy, technology and culture. Targets will be updated and new Indicators added to ensure it continues to deliver, and remains a living document.

By doing this we hope that we can build on our legacy of shaping London's neighbourhoods by inspiring and facilitating change across the property industry. Let's work together to make London's neighbourhoods healthier, greener, and better places to live. Let's build a sustainable city for the future.

## Next Steps

Technical Guidance documents are being produced for each of the nine Dimensions, and once these are complete they will be available through the TfL website. These will help project managers to implement the Indicators in practice.

The Handbook will be updated periodically as we continue to improve how we develop our sites sustainably.

In the coming year we will be developing an adaptation of this SDF so that it can be applied more comprehensively to existing built assets. This document will be built to support TfL Commercial Development's work across the existing estate – from railway viaduct arches to historic commercial premises – and will make our approach to sustainable development adaptable to all building types.

## Contact

To be kept updated or if you need support on how to implement the TfL Sustainable Development Framework, contact us at:

[sdf@tfl.gov.uk](mailto:sdf@tfl.gov.uk)

Sustainable Development Team  
TfL Commercial Development  
Palestra  
197 Blackfriars Road  
London SE1 8JZ

## Credits

We would like to recognise the following TfL staff, who directed and supported the creation and roll-out of the SDF:

SDF Leads:

**Derek Wilson**

Head of Sustainability,  
TfL Commercial Development

Derek served as the Strategic Lead on the SDF and was responsible for the framework's concept, structure, methodology and implementation.

**Lucy Atlee**

Design and Sustainability Manager,  
TfL Commercial Development

Lucy served as Technical Lead on the SDF, and was responsible for developing the Framework's Indicators and technical guidance, in addition to leading internal consultation.

**Tom Sykes**

Design & Quality Team Lead,  
TfL Commercial Development

Tom served as the Chair of the SDF Working Group and Editor of the SDF. He was responsible for coordinating internal engagement and producing the Handbook and Guidance Documents.

SDF Working Group:

**Scott Anderson**  
**Patricia Cazes-Potgieter**  
**Jonathan Cornelius**  
**Peter Elliott**  
**Steve Lugg**  
**Darren Smilie**  
**Ben Tate**

**Quinten Babcock**  
**Mary Brown**  
**Caroline Cameron**  
**Lee Campbell**  
**Anjna Farmah**  
**Sharon Giffen**  
**Alex Gilbert**  
**Richard Groves**  
**Emma Hatch**  
**Puja Jain**  
**Siobhan Jared**  
**Alexandra Jezeph**  
**Laura Miller**  
**Martin Mohamad**  
**Rosanna Sterry**  
**Sergio Valsamis**  
**Sandy Walker**

## Other Contributors

We would like to thank the following individuals, who provided technical expertise and helped to review the SDF's Indicators and guidance:

**Tim Aldham** GLA  
**Philippa Bancroft** GLA  
**Ben Bost** TfL  
**Matt Christie** GLA  
**Alejandro Colsa** GLA  
**Katherine Drayson** TfL  
**Matthew Galvin** TfL  
**Siwan Hayward** TfL  
**Sam Longman** TfL  
**Francis McIlroy** TfL  
**Arjun Nanu** TfL  
**Olu Oluwole** TfL  
**Tim Rudin** TfL  
**Michelle Ryan** TfL  
**Charles Snead** TfL  
**John Strutton** TfL  
**Simone West** TfL  
**Jonathan Woolmer** TfL

## TfL Sustainable Development Advisory Panel

The SDF was supported and informed by a panel of expert advisors, who have volunteered their time and energy to help TfL create a best-in-class approach to sustainable development. The panel includes:

**Stephen Howlett CBE DL** Chair of the Panel  
**Clara Bagenal-George** Chair, LETI  
**Ashley Bateson** Head of Sustainability and Partner, Hoare Lea  
**Lee Bishop** Major Developments Director, Taylor Wimpey  
**Christopher Choa** Founder, Outcomist  
**Fiona Fletcher-Smith** CEO, L&Q  
**Charlotte Hopkinson** Head of Sustainability, Grainger Plc  
**Mark Jenkinson** Managing Director, Crystal Associates  
**Anne Kavanagh** CIO, Patrizia  
**Stuart Robinson** Chair, HS2 Development Board  
**Sowmya Parthasarathy** Urban Design Leader, Arup  
**Chris Trott** Head of Sustainability & Senior Partner, Foster + Partners  
**Sara Turnbull** Founder, Workwild  
**Jane Wakiwaka** Head of Sustainability, The Crown Estate

## Collaborators

We would like to thank the consultants and suppliers who collaborated with us on the SDF and associated guidance:

### Lead Consultants:



### Indicator Authors



### Supporting Consultants



## Industry Partners

We would like to thank the following companies for their instrumental role in supporting the development of the SDF:



## Organisations

We would like to thank the following organisations for their collaboration, support, and thought leadership:



Illustrations:  
Gilbert Leung

Design:  
Objectif

Copy editor:  
Jessica Cargill Thompson

© Transport for London, 2021