

THE OFFICIAL ASE STUDY GUIDE

# ASE Automobile Tests



ALSO INCLUDES LIGHT VEHICLE/CNG, EXHAUST SYSTEMS, & AUTO SERVICE CONSULTANT TESTS



National Institute for  
**AUTOMOTIVE  
SERVICE  
EXCELLENCE**

---

# ASE AUTOMOBILE TESTS

## *Table of Contents*

<b>Overview .....</b>	<b>3–8</b>
<b><i>Automobile Tests</i> .....</b>	<b>9–64</b>
• Engine Repair (A1).....	9
• Automatic Transmission/Transaxle (A2).....	15
• Manual Drive Train and Axles (A3).....	20
• Suspension and Steering (A4) .....	26
• Brakes (A5).....	33
• Electrical/Electronic Systems (A6).....	40
• Heating and Air Conditioning (A7) .....	46
• Engine Performance (A8).....	51
• Light Vehicle Diesel Engines (A9).....	58
<b><i>Service Consultant Test</i>.....</b>	<b>65–69</b>
• Automobile Service Consultant (C1).....	65
<b><i>Alternate Fuels Test</i> .....</b>	<b>70–74</b>
• Compressed Natural Gas Vehicle (F1) .....	70
<b><i>Specialty Tests</i>.....</b>	<b>75–79</b>
• Exhaust Systems (X1).....	75
<b><i>Test Prep &amp; Training</i>.....</b>	<b>80</b>

---

# OVERVIEW

## Introduction

The Official ASE Study Guide for Automobile Tests is designed to help technicians prepare for the ASE certification tests. This guide contains detailed information about these tests which cover technology found in most of today's automobiles, sport utility vehicles, and light trucks. The task list for each test, found in the following pages, should help you review your technical knowledge. Your focus should be on less familiar topics. This should make it easier to select additional reference materials that will help you prepare for your test(s).

ASE's voluntary certification helps technicians prove their abilities to themselves, to their employers, and to their customers. By passing the tests and submitting appropriate work experience, you will earn the most valuable credential available to automotive technicians. Because the tests are challenging, you'll have the satisfaction of knowing you are among the elite in your profession. What's more, these credentials are recognized throughout the U.S.

Certified technicians promote customer trust and improve the image of the industry. And trust and professionalism are the first steps to a better, more prosperous business. ASE encourages you to take the tests and to join the proven pros who wear the ASE Blue Seal of Excellence®.

## How Do I Become Certified?

There are nine tests in the Automobile Technician certification series. If you pass one or more test(s) and have at least two years of hands-on working experience in automotive repair (appropriate training may substitute for up to one year of experience), you will become certified as an ASE Automobile Technician.

If you pass tests A1 through A8 and meet the experience requirement, you will earn certification as a Master Automobile Technician. Note: Test A9 is not required for Master Automobile Technician status.

Your test results will be emailed to you immediately following your testing appointment. Results will not be given over the phone nor will they be released to anyone without your written permission. If you fail a test, you must wait 30 days from the test date before you can purchase it again.

## OVERVIEW (CONTINUED)

Certification credentials are valid for five years. Recertification ensures certified technicians are seen as up-to-date in their profession. If you have been certified in an area for almost five years, it is time to register for the corresponding recertification test. Most recertification tests are about half the length of the initial certification tests.

### Automobile & Other Tests

This Study Guide contains Test Specifications, Task Lists, and sample questions for the following ASE tests:

- Automobile Tests: Engine Repair (Test A1); Automatic Transmission/Transaxle (Test A2); Manual Drive Train and Axles (Test A3); Suspension and Steering (Test A4); Brakes (Test A5); Electrical/Electronic Systems (Test A6); Heating and Air Conditioning (Test A7); Engine Performance (Test A8); and Light Vehicle Diesel Engines (Test A9)
- Service Consultant Test: Automobile Service Consultant (Test C1)
- Alternate Fuels Test: Compressed Natural Gas Vehicle (Test F1)
- Specialty Tests: Exhaust Systems (Test X1)

Some of these tests are prerequisites for the Advanced Level tests. You must have passed test A8 before you can take the Advanced Engine Performance Specialist (L1) Test. To take the Light Duty Hybrid/Electric Vehicle Specialist (L3) Test, you must have passed both the A6 and A8 tests.

You must hold current certification in both A4 and A5 to register for test X1 (regular or recertification). When you pass X1, you will be certified as an Undercar Specialist.

ASE also offers certification in Medium/Heavy Truck, Truck Equipment, School Bus, Transit Bus, Maintenance & Light Repair, Collision Repair/Refinish, Parts Specialist, and Advanced Level specialties. Separate Study Guides are available for those test series.

For full information on ASE testing as well as downloadable Study Guides and other test preparation resources, visit [www.ase.com](http://www.ase.com).

### Who Writes the Questions?

Working professionals from the service industry with expertise in the test topic write the questions, which are entirely job-related. The questions are designed to test knowledge of the skills that you need to know in servicing automobiles; theoretical knowledge is not covered.

## OVERVIEW (CONTINUED)

### How Long are the Tests?

ASE Tests 2022		Certification Tests		Recertification Tests	
	Name	Number of questions	Testing time	Number of questions	Testing time
<b>Automobile / Light Truck Tests †</b>					
<b>A1</b>	Engine Repair	60*	1 1/4 hrs	25	30 mins
<b>A2</b>	Automatic Transmission / Transaxle	60*	1 1/4 hrs	25	30 mins
<b>A3</b>	Manual Drive Train and Axles	50*	1 hr	20	30 mins
<b>A4</b>	Suspension and Steering	50*	1 hr	20	30 mins
<b>A5</b>	Brakes	55*	1 1/4 hrs	23	30 mins
<b>A6</b>	Electrical / Electronic Systems	60*	1 1/2 hrs	25	45 mins
<b>A7</b>	Heating and Air Conditioning	60*	1 1/4 hrs	25	30 mins
<b>A8</b>	Engine Performance	60*	1 1/4 hrs	25	45 mins
<b>A9</b>	Light Vehicle Diesel Engines	60*	1 1/4 hrs	25	30 mins
<b>Service Consultant Test</b>					
<b>C1</b>	Automobile Service Consultant	60*	1 1/4 hrs	23	30 mins
<b>Alternate Fuels Test</b>					
<b>F1</b>	Compressed Natural Gas Vehicles	65*	1 1/2 hrs	28	45 mins
<b>Specialty Test</b>					
<b>X1</b>	Exhaust Systems	50*	1 hr	20	30 mins

\* Certification tests contain 10 additional research questions that are not counted for score. However, since you don't know which questions count, you should answer every question. You must have previously passed the certification test to be eligible for the shorter recertification test.

† In Automobile tests (A1-9), click on the "Leer en español" button to call up a side-by-side Spanish/English rendering of the question and answer options. No special registration process is needed. You can find more information on this option at [www.ase.com/spanish](http://www.ase.com/spanish).

Each question has its roots in an ASE “item-writing” workshop where working technicians, service representatives from automobile manufacturers (domestic and import), aftermarket parts and equipment manufacturers and technical educators meet to share ideas and translate them into test questions. Each question written must survive review by all members of the group. The questions are written to mirror practical problems relevant to the diagnosis and repair performed by technicians in their day-to-day work.

After being written, all questions are pre-tested and quality-checked on a national sample of technicians. Those questions meeting ASE standards of quality and accuracy are then included in the scored sections of the tests; those that do not are redrafted or discarded altogether.

## How Do I Prepare for the ASE Tests?

The most important thing you can do is become familiar with test content and question formats.

The Test Specifications in this booklet describe the content covered by each test. The Task Lists detail the actual work performed by technicians in each specialty area. Together, these are the blueprint for writing and assembling the ASE tests.

Each question on the test relates to a particular task or set of tasks in the task list. Therefore, review the task list, thinking about whether you know how to perform each task listed.

All questions are multiple-choice. The sample questions in this Study Guide are examples of the five types of questions on the test. Note there are different instructions for some question types.

Read each question carefully so that you understand exactly what is being asked. Each question tests a specific diagnostic or repair problem and has only one correct answer.

To summarize, we suggest the following steps be taken:

- Step 1.** Carefully read the Test Specifications for each test you will attempt.
- Step 2.** Study the Task List for each area.
- Step 3.** Go over the sample questions to become familiar with each question type. This is very important!
- Step 4.** Review steps 1 through 3 and identify the skill areas where you need additional study.

## Getting Started

### Bring--

- ✓ Admission Ticket
- ✓ Current Government Issued Photo ID

### Leave in locker--

- ✓ Books
- ✓ Calculator
- ✓ Coat
- ✓ Cell Phone
- ✓ Smart Devices
- ✓ Wallet
- ✓ Keys

Registration information is available at [www.ase.com](http://www.ase.com). This site shows testing locations and provides other important information, including an electronic version of all ASE Study Guides.

While on the ASE website, take a moment to create your own myASE account (if you do not already have one), which allows you to register for tests, make test appointments, and have direct access to your personal ASE certification information. Should you have questions that the website does not answer, you can reach our helpful customer service staff at [contactus@ase.com](mailto:contactus@ase.com) or 800-390-6789.

## At the Test Center—Some Tips

Try to be well rested on exam day. Allow extra time to find parking and the Test Center office. Late arrivals may be turned away by Test Center staff. If you cannot take a test because you are late, you will forfeit your test fees.

Bring your Admission Ticket and unexpired, government-issued photo ID with you. Books, notes, calculators, and electronic devices (including cell phones) are not permitted in the test room. You will be assigned a locker to store personal items. Most test centers have airport-level security procedures for all candidates, so be prepared for “wandering” or other security checks.

You will receive scratch paper and pencils, and for some advanced level tests, a printed reference booklet. Each test appointment begins with a short tutorial on the operation of the testing platform. You may also preview the platform online at [www.ase.com/asedemo](http://www.ase.com/asedemo) before you arrive at the Test Center. If Spanish is your first language, you can use the "Leer en español" button to see a split-screen, Spanish/English rendering of questions and answer options in certain tests (A1-9, G1).

Each test has a time limit, as listed in the chart on page 5. After you start your test, the computer screen will continuously display the amount of time left. If you finish early, you can either review your answers or end the test and continue to

## OVERVIEW (CONTINUED)

the next test (if you are taking more than one). Once you submit a test for scoring, you cannot go back and review it. If you are taking several tests and need a short break, take it between tests. Take your break when you reach the screen that asks if you are taking additional tests. Do not take a break during a test as the test clock will continue to run.

If a question is difficult, mark the answer that you think is correct and flag the question using the on-screen button. Then go on to the next question. When you have finished the test, you may have time to go back to the flagged questions. Your score is based on the number of correct answers, so you should try to answer every question.

When you finish your last test, you will be given a short customer satisfaction survey. After you complete the survey, inform the staff and leave. When you check your email, your test results will be waiting for you! If you need a paper copy right away, ask the staff to print your results before you leave the test center.

## Test Content and Sample Questions

To help you prepare, each section begins with the Test Specifications, which will list the main categories covered and the number of test questions, as well as the percentage of the test devoted to each topic.

The Task List describes the work activities a technician should be able to perform. This list was developed by working technicians and technical experts from across the country and will provide a valuable checklist telling you what you should know for the test.

The number of tasks listed does not equal the number of questions. Although every question relates to at least one listed task, some tasks may not appear on the test. Some complex tasks may be covered by several questions. Some questions may cover multiple simple tasks. The main goal of the list is to describe what is done on the job; any task on the list **may be** covered on the test.

Sample questions follow the Task List. Although these specific questions will not appear on tests, they are in the same format as actual test questions. The ASE tests employ several types of multiple-choice questions. Note that some questions have special instructions, which will appear with similar questions on the ASE tests. ■

## TEST SPECIFICATIONS AND TASK LIST ENGINE REPAIR (TEST A1)

Content Area	Questions in Test	Percentage of Test
A. General Engine Diagnosis	15	30%
B. Cylinder Head and Valve Train Diagnosis and Repair	10	20%
C. Engine Block Diagnosis and Repair	10	20%
D. Lubrication and Cooling Systems Diagnosis and Repair	8	16%
E. Fuel, Electrical, Ignition, and Exhaust Systems Inspection and Service	7	14%
<b>Total</b>	<b>50</b>	<b>100%</b>

### A. General Engine Diagnosis (15 questions)

1. Verify customer concern and/or road test vehicle; determine needed action.
2. Determine if no-cranking, cranks but will not start, or hard starting condition is an engine mechanical problem, or is caused by another vehicle subsystem.
3. Inspect engine assembly for fuel, oil, coolant and other leaks; determine needed action.
4. Isolate engine noises and vibrations; determine needed action.
5. Diagnose the cause of excessive oil consumption, coolant consumption, unusual engine exhaust color and odor; determine needed action.
6. Perform engine manifold vacuum or pressure tests; determine needed action.
7. Perform cylinder power balance tests; determine needed action.
8. Perform cylinder compression tests; determine needed action.
9. Perform cylinder leakage/leak-down tests; determine needed action.
10. Research system operation using technical information to determine service procedures and specifications.

### B. Cylinder Head and Valve Train Diagnosis and Repair (10 questions)

1. Remove cylinder heads, disassemble, clean, and prepare for inspection.
2. Visually inspect cylinder heads for cracks, warpage, corrosion, leakage, and the condition of passages; determine needed repairs.
3. Inspect and repair damaged threads where allowed; install core and gallery plugs.
4. Inspect, test, and verify valve springs for squareness, pressure, and free height comparison; replace as needed.
5. Inspect valve spring retainers, rotators, valve locks, and valve lock grooves.
6. Replace valve stem seals.
7. Inspect valve guides for wear; check valve stem-to-guide clearance; determine needed repairs.
8. Inspect valves and valve seats; determine needed repairs.
9. Check valve spring installed (assembled) height and valve stem height; determine needed repairs.



---

## A1 TASK LIST (CONTINUED)

10. Inspect pushrods, rocker arms, rocker arm pivots, and rocker arm shafts for wear, bending, cracks, looseness, and blocked oil passages; repair or replace as required.
11. Inspect hydraulic or mechanical lifters/lash adjusters; replace as needed.
12. Adjust valves on engines with mechanical or hydraulic lifters.
13. Inspect camshaft drive gear train components (includes gear, chain and belt systems); repair or replace as needed.
14. Inspect and measure camshaft journals and lobes; measure camshaft lift; determine needed repairs.
15. Inspect and measure camshaft bore for wear, damage, out-of-round, and alignment; determine needed repairs.
16. Inspect valve timing; time camshaft(s) to crankshaft.
17. Inspect cylinder head mating surface condition and finish, reassemble and install gasket(s) and cylinder head(s); replace/torque bolts according to manufacturers' procedures.
18. Inspect overhead camshaft variable valve timing components; repair or replace as needed.
19. Inspect variable valve lift components; repair or replace as needed.

### C. Engine Block Diagnosis and Repair (10 questions)

1. Remove and disassemble engine block; clean, identify selective parts, mark location and orientation, and prepare components for inspection and reassembly.
2. Visually inspect engine block for cracks, corrosion, the condition of passages, core and gallery plug hole condition, surface warpage, and surface finish and condition; inspect piston oil cooling nozzle/jets for damage, proper alignment and restrictions; determine needed action.
3. Inspect and repair damaged threads where allowed; install core and gallery plugs.
4. Clean and inspect cylinder walls; measure cylinder bore; determine needed action.
5. Inspect crankshaft for endplay, journal damage, keyway damage, visual surface cracks, thrust flange and sealing surface condition; check oil passage condition; measure journal wear; check crankshaft reluctor ring/tone wheel (where applicable); determine needed action.
6. Inspect main bearing wear patterns; inspect and measure main bearing bores and cap alignment; mark caps for location and direction; clean and inspect crankshaft girdle (bed plate/ladder) where applicable.
7. Install main bearings and crankshaft; check bearing clearances and endplay; inspect, replace and torque bolts according to manufacturer's procedures.
8. Inspect camshaft bearings for excessive wear and alignment; replace bearings if necessary; install camshaft, timing chain and gears; check endplay.
9. Inspect auxiliary (balance, intermediate, idler, counterbalance or silencer) shaft(s), drive(s)/gear(s), chain(s), and support bearings for damage and wear; time balance shaft to crankshaft; determine needed action.
10. Inspect, measure, service or replace pistons and piston/wrist pins; identify piston and bearing wear patterns caused by connecting rod alignment concerns; determine needed action.
11. Inspect connecting rods and bearings for damage, bore condition, and pin fit; mark caps for location and direction; determine needed action.
12. Inspect, measure, and install or replace piston rings; assemble piston and connecting rod; install piston/rod assembly; check bearing clearance and sideplay; install connecting rod bearings; inspect, replace and torque fasteners according to manufacturer's procedures.

---

## A1 TASK LIST (CONTINUED)

13. Inspect, reinstall or replace crankshaft vibration damper/harmonic balancer.
14. Inspect crankshaft flange and flywheel mating surfaces; inspect and replace crankshaft pilot bearing/bushing (if applicable); inspect flywheel/flexplate and flywheel ring gear for cracks and wear (includes dual-mass flywheel); measure flywheel runout; determine needed action.
15. Inspect and replace pans and covers.
16. Assemble the engine using gaskets, seals, formed-in-place (tube-applied) sealants, and thread sealers according to manufacturers' specifications; reinstall engine; prime lubrication system as needed.
17. Inspect in-block camshaft variable valve timing components; repair or replace as needed.
18. Inspect cylinder deactivation system; determine needed action.

### D. Lubrication and Cooling Systems Diagnosis and Repair (8 questions)

1. Diagnose engine lubrication system problems; perform oil pressure tests; perform engine oil dye test; determine needed action.
2. Disassemble and inspect oil pump (includes gears, rotors, housing, pick-up assembly and variable displacement components); measure oil pump clearance; inspect pressure relief devices, control systems, and pump drive (includes belt/chain drive); determine needed action.
3. Inspect, flush, and test internal and external engine oil coolers; determine needed action.
4. Change engine oil and filter(s) using proper type, viscosity, and rating per manufacturer's specifications.
5. Perform cooling system pressure tests; perform coolant dye test; determine needed action.
6. Inspect and test radiator, heater core, pressure cap, and coolant recovery system; replace as required.
7. Inspect, reinstall or replace, and adjust drive belt(s), tensioner(s), and pulleys.
8. Inspect and replace engine cooling system and heater system hoses, pipes, fittings and valves.
9. Inspect, test, reinstall or replace thermostat, coolant by-pass, and thermostat housing (including electronically controlled thermostats).
10. Inspect and replace water pump(s) (including electrical water pumps).
11. Inspect and test coolant; drain, flush, and refill cooling system with recommended coolant; bleed air as required.
12. Inspect and test fan (both electrical and mechanical), fan clutch, fan shroud, air dams, and cooling fan electrical circuits; repair or replace as required.
13. Verify proper operation of engine related warning indicators.

### E. Fuel, Electrical, Ignition, and Exhaust Systems Inspection and Service (7 questions)

1. Inspect, clean or replace fuel injection system components (including gasoline direct injection/GDI), intake manifold, and gaskets.
2. Inspect, service or replace air filters, filter housings, and intake ductwork.
3. Inspect turbocharger/supercharger systems; determine needed action.
4. Test engine cranking system; determine needed repairs.
5. Inspect and test positive crankcase ventilation (PCV) system components; replace as needed.
6. Inspect and test ignition system components; replace as needed.
7. Inspect and diagnose exhaust system; determine needed repairs. ■

## SAMPLE QUESTIONS ENGINE REPAIR (TEST A1)

1. An engine makes a knocking noise with the transmission in DRIVE. The knocking noise is not heard in PARK or NEUTRAL. Which of these could be the cause?
  - (A) Excessive main bearing clearance
  - (B) Low oil pressure
  - \* (C) A cracked flexplate
  - (D) A broken piston ring
  
2. An engine is overheating and has white smoke coming from the tail pipe. The cooling system is pressure tested and will not hold pressure. This could be caused by:
  - \* (A) a blown head gasket.
  - (B) a restricted piston oil nozzle.
  - (C) a stuck-open thermostat.
  - (D) an incorrect PCV valve.
  
3. An engine compression test identifies that one cylinder has low compression. During a leak down test of the cylinder, excessive leakage is observed and air is heard coming out of the tail pipe. Which of these could be the cause?
  - (A) Broken piston rings
  - (B) A blown head gasket
  - (C) A leaking exhaust manifold gasket
  - \* (D) An exhaust valve not seating

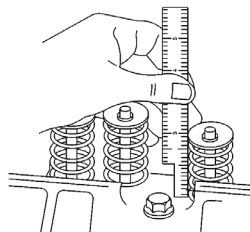

4. A technician is reassembling a cylinder head. In the illustration shown, which of these is the technician measuring?
  - (A) Installed stem height
  - (B) Valve spring squareness
  - \* (C) Installed spring height
  - (D) Valve spring pressure

## A1 SAMPLE QUESTIONS (CONTINUED)

5. An engine produces blue smoke when accelerating from a stop. Technician A says that worn exhaust valve guides could be the cause. Technician B says that worn exhaust valve seats could be the cause. Who is right?
  - (A) A only
  - (B) B only
  - (C) Both A and B
  - \* (D) Neither A nor B

6. To determine piston-to-cylinder wall clearance, the diameter of the piston shown should be measured at:
  - (A) W.
  - (B) X.
  - \* (C) Y.
  - (D) Z.

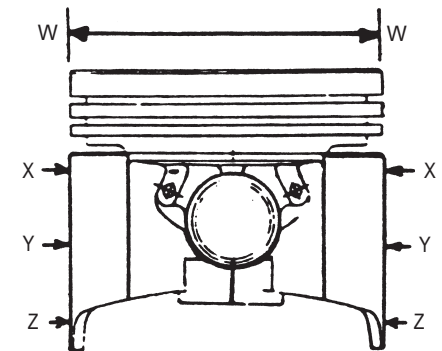

7. Technician A says that the setup shown can be used to check cylinder taper. Technician B says that the setup shown can be used to check cylinder out-of-round. Who is right?
  - (A) A only
  - (B) B only
  - \* (C) Both A and B
  - (D) Neither A nor B

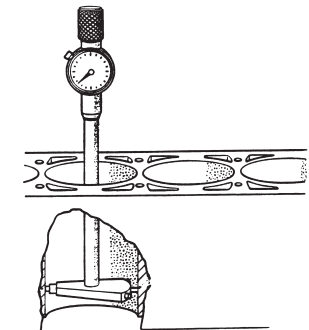

## A1 SAMPLE QUESTIONS (CONTINUED)

8. An engine overheats at higher rpms and returns to normal temperature at lower rpms. Which of these could be the cause?
- (A) A stuck-on cooling fan relay
  - \* (B) A worn water pump belt tensioner
  - (C) A restricted heater core
  - (D) An incorrect coolant concentration
9. A fuel-injected engine has low fuel pressure at the fuel rail test port. This could be caused by a:
- \* (A) restricted fuel filter.
  - (B) restricted fuel injector.
  - (C) stuck-closed fuel pressure regulator.
  - (D) shorted fuel injector.

***This question contains the word EXCEPT. Read the question carefully before choosing your answer.***

10. An engine with a variable valve timing (VVT) system has stored a VVT performance DTC. Any of these could be the cause EXCEPT a:
- \* (A) stuck-open oil filter bypass valve.
  - (B) restricted oil control solenoid screen.
  - (C) sticking camshaft actuator/phaser.
  - (D) restricted oil pump pickup screen.

## TEST SPECIFICATIONS AND TASK LIST AUTOMATIC TRANSMISSION/TRANSAXLE (TEST A2)

Content Area	Questions in Test	Percentage of Test
A. General Transmission/Transaxle Diagnosis	25	50%
1. Mechanical/Hydraulic Systems (11)		
2. Electronic Systems (14)		
B. In-Vehicle Transmission/Transaxle Maintenance and Repair	12	24%
C. Off-Vehicle Transmission/Transaxle Repair	13	26%
1. Removal and Installation (4)		
2. Disassembly and Assembly (5)		
3. Friction and Reaction Units (4)		
<b>Total</b>	<b>50</b>	<b>100%</b>

### A. General Transmission/Transaxle Diagnosis (25 questions)

#### 1. Mechanical/Hydraulic Systems (11 questions)

1. Road test the vehicle to verify mechanical/hydraulic system problems based on driver's concern; research vehicle service history; determine necessary action.
2. Diagnose noise, vibration, harshness, and shift quality problems; determine necessary action.
3. Diagnose fluid loss, type, level, and condition problems; determine necessary action.
4. Perform pressure tests; determine necessary action.
5. Diagnose torque converter stator/one-way clutch failure; determine necessary action.
6. Perform torque converter clutch (lock-up converter) mechanical/hydraulic system tests; determine necessary action.

#### 2. Electronic Systems (14 questions)

1. Road test the vehicle to verify electronic system problems based on driver's concern; research vehicle service history; determine necessary action.
2. Diagnose pressure concerns on transmissions equipped with electronic pressure control; determine necessary action.
3. Perform torque converter clutch (lock up converter) electronic system tests; determine necessary action.
4. Diagnose electronic transmission control systems using appropriate test equipment, service information, technical service bulletins, and schematics; diagnose problems in electrical/electronic circuits (including data communications); determine necessary action.



---

## A2 TASK LIST (CONTINUED)

5. Verify proper operation of charging system; check battery, connections, and power/ground circuits.
6. Differentiate between engine performance, or other vehicle systems, and transmission/transaxle related problems; determine necessary action.
7. Diagnose shift quality concerns resulting from problems in the electronic transmission control system; determine necessary action.

### B. In-Vehicle Transmission/Transaxle Maintenance and Repair (12 questions)

1. Inspect, adjust, and replace manual valve shift linkage and transmission range sensor/switch (inhibitor/neutral safety switch).
2. Inspect and replace external seals and gaskets.
3. Inspect and replace driveshaft yoke, drive axle joints, bushings, and seals.
4. Check condition and operation of engine cooling system; inspect transmission cooler, lines and fittings.
5. Inspect valve body mating surfaces, bores, valves, springs, sleeves, retainers, brackets, check balls, screens, spacer plates, and gaskets; replace as necessary.
6. Torque valve body fasteners to specification using the proper sequence.
7. Inspect accumulator and servo bores, pistons, seals, pins/pin bores, springs, and retainers; repair or replace as necessary.
8. Inspect, test, adjust, repair, or replace electrical/electronic components and circuits including control modules, solenoids, sensors, relays, terminals, connectors, switches, and harnesses; inspect, test, and verify control module inputs, outputs, and data communications.
9. Inspect, replace, and/or align power train mounts.
10. Replace fluid and filter(s); verify proper fluid level and type (for transmissions with, or without, a dipstick).

### C. Off-Vehicle Transmission/Transaxle Repair (13 questions)

#### 1. Removal and Installation (4 questions)

1. Remove and install transmission/transaxle; inspect engine core plugs, rear crankshaft seal, transmission dowel pins, dowel pin holes, and mating surfaces.
2. Inspect converter flex (drive) plate, converter attaching bolts, converter pilot, crankshaft pilot bore, converter pump drive surfaces.
3. Install torque converter and establish correct converter-to-pump engagement; inspect converter free movement for pilot engagement during transmission installation.
4. Inspect, test, flush or replace transmission fluid cooler.
5. Inspect brackets, wiring harnesses, fuel lines, heat shields, inspection covers, vents, cooler lines, and related components for proper routing and installation.
6. Perform module or component coding and/or programming (including adaptive learning reset); road test to confirm proper operation.

#### 2. Disassembly and Assembly (5 questions)

1. Disassemble, clean, and inspect transmission case, sub-assemblies, mating surfaces, and thread condition.
2. Inspect and measure fluid pump components; replace as necessary.
3. Check bearing preload; inspect, measure, and adjust as needed.

---

## A2 TASK LIST (CONTINUED)

4. Check end play; inspect, measure, and adjust as needed.
5. Inspect shafts; replace as necessary.
6. Inspect fluid delivery circuit, including seal rings, ring grooves, sealing surface areas, feed pipes, orifices, and encapsulated check valves (balls).
7. Inspect and/or measure bushings, thrust washers, and bearings; replace as necessary.
8. Inspect and measure components of the planetary gear assembly; replace as necessary.
9. Inspect case bores, passages, bushings, vents, mating surfaces, and dowel pins; repair or replace as necessary.
10. Inspect valve body mating surfaces, bores, valves, solenoids, springs, sleeves, retainers, brackets, check balls, screens, spacer plates, and gaskets; replace as necessary.
11. Inspect transmission/transaxle drive chains, sprockets, belts, pulleys/sheaves, gears, bearings, and bushings; replace as necessary.
12. Inspect and measure transaxle final drive components; repair, replace and/or adjust as necessary.
13. Assemble after repair.

#### 3. Friction and Reaction Units (4 questions)

1. Inspect components of the hydraulic clutch pack assembly; replace as necessary.
2. Measure clutch pack clearance; adjust as necessary.
3. Air test the operation of clutch and servo assemblies.
4. Inspect components of one way clutch assemblies; replace as necessary.
5. Inspect bands and drums ( housings/cylinders); replace and/or adjust as necessary. ■

## SAMPLE QUESTIONS

### AUTOMATIC TRANSMISSION/TRANSAXLE (TEST A2)

1. An automatic transmission does not hold in PARK.  
Technician A says that misadjusted shift linkage could be the cause.  
Technician B says that a roller clutch installed backwards could be the cause.  
Who is right?  
\* (A) A only  
(B) B only  
(C) Both A and B  
(D) Neither A nor B
2. A vehicle with an automatic transaxle and a properly tuned engine accelerates poorly from a stop. Acceleration is normal above 35 mph. Which of these could be the cause?  
(A) A worn front pump  
\* (B) A failed torque converter  
(C) A worn planetary gear set  
(D) A low fluid level
3. The transmission slips when cold. Which of these could be the cause?  
(A) A shorted low/reverse pressure switch  
(B) Line pressure is at maximum in 1st gear  
(C) A disconnected line pressure sensor  
\* (D) Low line pressure
4. The automatic transaxle upshifts harshly during normal acceleration. The cause could be a failed:  
(A) oxygen sensor.  
(B) idle air control valve.  
\* (C) throttle position sensor.  
(D) intake air temperature sensor.

## A2 SAMPLE QUESTIONS (CONTINUED)

5. With the transmission pan removed, the best way to pin-point an oil pressure leak is to:

- (A) check the filter pick-up tube seal.
- (B) check the line pressure.
- (C) remove and check the valve body.
- \* (D) perform an air pressure test.

6. The tool in the setup shown is being used to remove the:

- \* (A) stator support bushing.
- (B) stator support seal.
- (C) pump body torque converter support bushing.
- (D) pump body torque converter seal.

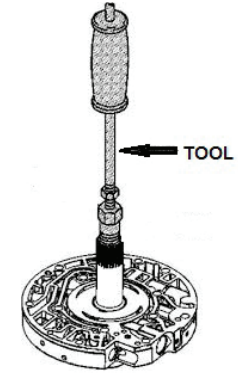

7. A vehicle with an OBD II computer system has stored transmission trouble codes. After repairs are completed, the trouble codes should be cleared by:

- (A) disconnecting the battery.
- (B) disconnecting the TCM.
- \* (C) using a scan tool.
- (D) removing the TCM fuse.

***This question contains the word EXCEPT. Read the question carefully before choosing your answer.***

8. Too much automatic transmission shaft endplay could be caused by any of these EXCEPT a worn:

- \* (A) clutch.
- (B) selective washer.
- (C) transmission case.
- (D) planetary carrier.

# TEST SPECIFICATIONS AND TASK LIST

## MANUAL DRIVE TRAIN AND AXLES (TEST A3)

Content Area	Questions in Test	Percentage of Test
A. Clutch Diagnosis and Repair	6	16%
B. Transmission Diagnosis and Repair	7	17%
C. Transaxle Diagnosis and Repair	7	17%
D. Drive Shaft/Half-Shaft and Universal Joint/Constant Velocity (CV) Joint Diagnosis and Repair (Front and Rear Wheel Drive)	5	13%
E. Drive Axle Diagnosis and Repair	7	17%
F. Four-Wheel Drive/All-Wheel Drive Component Diagnosis and Repair	8	20%
<b>Total</b>	<b>40</b>	<b>100%</b>

### A. Clutch Diagnosis and Repair (6 questions)

1. Diagnose clutch noise, binding, slippage, pulsation, chatter, pedal feel/effort, and release problems; determine needed repairs.
2. Inspect, adjust, and replace clutch pedal linkage, brackets, bushings, pivots, springs, and electrical switches/sensors.
3. Inspect, adjust, replace, and bleed hydraulic clutch slave/release cylinder, master cylinder, lines, hoses, delay valve(s) and accumulator/ddamper; clean and flush hydraulic system; refill with proper fluid.
4. Inspect, adjust, and replace release (throw-out) bearing, bearing retainer, lever, and pivot.
5. Inspect, adjust and replace clutch disc and pressure plate assembly; inspect input shaft pilot and splines.
6. Inspect pilot bearing/bushing inner and outer bores; inspect and replace pilot bearing/bushing.
7. Inspect and measure flywheel and ring gear; inspect dual-mass flywheel where required; repair or replace as necessary.
8. Inspect engine block, clutch (bell) housing, transmission case mating surfaces, and alignment dowels; inspect engine core plugs, rear main engine seal, and other sources of fluid contamination; determine needed repairs.
9. Measure flywheel runout and crankshaft endplay; determine needed repairs.
10. Inspect, replace, and align powertrain mounts.

## A3 TASK LIST (CONTINUED)

### B. Transmission Diagnosis and Repair (7 questions)

1. Diagnose transmission noise, difficult shifting, gear clash, jumping out of gear, fluid condition and type, and fluid leakage problems; determine needed repairs.
2. Inspect, adjust, lubricate and replace transmission external shift assemblies, linkages, brackets, bushings/grommets, cables, pivots, and levers.
3. Inspect and replace transmission gaskets, sealants, seals, and fasteners; inspect sealing surfaces.
4. Remove and replace transmission; inspect transmission mounts.
5. Disassemble and clean transmission components; reassemble transmission.
6. Inspect, repair, and/or replace transmission shift cover and internal shift forks, bushings, bearings, levers, shafts, sleeves, detent mechanisms, interlocks, and springs.
7. Inspect and replace input (clutch) shaft, bearings, and retainers.
8. Inspect and replace output (main) shaft, gears, thrust washers, bearings, and retainers/snap rings; measure clearance and endplay.
9. Inspect and replace synchronizer hub, sleeve, keys (inserts), springs, and blocking (synchronizing) rings/mechanisms; measure blocking ring clearance.
10. Inspect and replace countershaft, counter (cluster) gear, bearings, thrust washers, and retainers/snap rings.
11. Inspect and replace reverse idler gear, shaft, bearings/bushings, thrust washers, and retainers/snap rings.
12. Measure and adjust bearing preload or endplay (shim/spacer selection procedure).
13. Inspect, repair, and replace extension housing and transmission case mating surfaces, bores, dowels, bushings, and vents.
14. Inspect, test, replace and calibrate transmission sensors, actuators, and switches.
15. Inspect, test, and repair lubrication system, pumps, coolers and plumbing..
16. Check transmission fluid level; refill with proper fluid.
17. Inspect, test, adjust, repair or replace electrical/electronic components and circuits including control modules, solenoids, sensors, relays, terminals, connectors, switches, and harnesses; inspect, test, and verify control module inputs, outputs, and data communications.

### C. Transaxle Diagnosis and Repair (7 questions)

1. Diagnose transaxle noise, difficult shifting, gear clash, jumping out of gear, fluid condition and type, and fluid leakage problems; determine needed repairs.
2. Inspect, adjust, lubricate and replace transaxle external shift assemblies, linkages, brackets, bushings/grommets, cables, pivots, and levers.
3. Inspect and replace transaxle gaskets, sealants, seals, and fasteners; inspect sealing surfaces.
4. Remove and replace transaxle; inspect, replace, and align transaxle mounts and subframe/cradle assembly.
5. Disassemble and clean transaxle components; reassemble transaxle.
6. Inspect, repair, and/or replace transaxle shift cover and internal shift forks, levers, bushings, shafts, sleeves, detent mechanisms, interlocks, and springs.
7. Inspect and replace input (clutch) shaft and output (main) shaft, gears, thrust washers, bearings, and retainers/snap rings.

### A3 TASK LIST (CONTINUED)

8. Inspect and replace synchronizer hub, sleeve, keys (inserts), springs, and blocking (synchronizing) rings; measure blocking ring clearance.
9. Inspect and replace reverse idler gear, shaft, bearings/bushings, thrust washers, and retainers/snap rings.
10. Inspect, repair, and/or replace transaxle case mating surfaces, bores, dowels, bushings, bearings, and vents.
11. Inspect, test, and replace transaxle sensors, actuators, and switches.
12. Diagnose differential assembly noise and wear; determine needed repairs.
13. Remove and replace differential final drive assembly.
14. Inspect, measure, adjust and replace differential pinion (spider) gears, shaft, side gears, thrust washers, side bearings, and case/carrier.
15. Diagnose limited slip differential noise, slippage, and chatter problems; determine needed repairs.
16. Measure and adjust shaft and differential bearing preload and endplay (shim/spacer selection procedure).
17. Inspect, test, and repair lubrication system, pumps, coolers, and plumbing.
18. Check transaxle fluid level; refill with proper fluid.
19. Inspect, test, adjust, repair or replace electrical/electronic components and circuits including control modules, solenoids, sensors, relays, terminals, connectors, switches, and harnesses; inspect, test, and verify control module inputs, outputs, and data communications.

#### D. Drive Shaft/Half-Shaft and Universal Joint/Constant Velocity (CV) Joint Diagnosis and Repair (Front and Rear Wheel Drive) (5 questions)

1. Diagnose drive/half shaft and universal/CV joint noise and vibration problems; determine needed repairs.
2. Inspect, service, and replace shafts, slip joints, yokes, boots, and universal/CV/flexible disc joints; verify proper phasing.
3. Inspect, service, and replace center support and intermediate shaft bearings.
4. Check drive/propeller shaft balance; determine needed action.
5. Measure drive shaft runout.
6. Measure and adjust drive shaft working angles.
7. Diagnose, inspect, service, and replace wheel bearings, seals, and hubs.

#### E. Drive Axle Diagnosis and Repair (7 questions)

##### ► Ring and Pinion Gears

1. Diagnose noise, vibration, and fluid leakage problems; determine needed repairs.
2. Inspect and replace companion flange, yoke, and pinion seal; measure companion flange runout.
3. Measure ring gear runout; determine needed repairs.
4. Inspect and replace ring and pinion gear set, collapsible spacers/crush sleeves, shims, and bearings.
5. Measure and adjust drive pinion depth.
6. Measure and adjust drive pinion bearing preload (collapsible spacer/crush sleeves or shim type).

### A3 TASK LIST (CONTINUED)

7. Measure and adjust differential (side) bearing preload, and ring and pinion backlash (threaded adjuster or shim type).
8. Perform ring and pinion tooth contact pattern checks; determine needed adjustments.

##### ► Differential Case/Carrier Assembly

9. Diagnose differential assembly noise and vibration problems; determine needed repairs.
10. Remove and replace differential assembly.
11. Inspect, measure, adjust, and replace differential pinion (spider) gears, shaft, side gears, thrust washers, side bearings, and case/carrier.
12. Measure differential case/carrier runout; determine needed repairs.

##### ► Limited Slip/Locking Differential

13. Diagnose limited slip differential noise, slippage, and chatter problems; determine needed repairs.
14. Inspect, drain, and refill with proper lubricant.
15. Inspect, adjust, repair or replace limited slip or locking assembly components.
16. Inspect, test, replace, and calibrate sensors, control modules, actuators, and switches.

##### ► Axle Shafts and Housing

17. Diagnose rear axle shaft noise, vibration, and fluid leakage problems; determine needed repairs.
18. Inspect and replace rear axle shaft wheel studs.
19. Remove, inspect, adjust, and/or replace rear axle shafts, splines, seals, bearings, and retainers.
20. Measure rear axle flange runout and shaft endplay; determine needed repairs.
21. Inspect axle housing and vent.

#### F. Four-Wheel Drive/All-Wheel Drive Component Diagnosis and Repair (8 questions)

1. Diagnose drive systems noise, vibration, leakage and steering problems; determine needed repairs.
2. Inspect, repair, replace, adjust, and calibrate transfer case manual shifting mechanisms, bushings, mounts, levers, and brackets.
3. Remove and replace transfer case.
4. Disassemble transfer case; clean and inspect internal transfer case components; determine needed repairs.
5. Reassemble transfer case.
6. Check transfer case fluid level; drain and refill with proper fluid; reset service parameters as required.
7. Inspect, service, and replace drive/propeller shaft and universal/CV joints.
8. Inspect, service, and replace drive axle universal/CV joints and drive/half-shafts.
9. Inspect, service, and replace wheel bearings, seals, and hubs.
10. Check transfer case, axle seals, and all vents.
11. Diagnose drive system actuation and engagement concerns; repair or replace components as necessary (including: viscous, hydraulic, magnetic, mechanical, vacuum, and electrical/electronic); calibrate/initialize as necessary.
12. Inspect tires for condition and matching circumference; verify proper size for vehicle application. ■

## SAMPLE QUESTIONS

### MANUAL DRIVE TRAIN AND AXLES (TEST A3)

1. Excessive brass filings are found in the fluid of a manual transmission. Which of these could be the cause?

(A) Loose main shaft bearings  
 (B) Loose countershaft bearings  
 \* (C) Worn blocker rings  
 (D) Broken input shaft gear teeth

2. A manual transaxle makes a clunking noise on acceleration and on deceleration.

Technician A says that a loose differential case pinion shaft could be the cause.

Technician B says that a worn clutch release bearing could be the cause.

Who is right?

\* (A) A only  
 (B) B only  
 (C) Both A and B  
 (D) Neither A nor B

3. A front-wheel drive vehicle has a vibration only when cornering. Which of these could be the cause?

(A) An out-of-balance tire  
 \* (B) A worn CV joint  
 (C) A worn ring gear  
 (D) An out-of-balance axle shaft

4. Using the illustration shown, the technician is measuring pinion bearing:

(A) backlash.  
 (B) runout.  
 \* (C) preload.  
 (D) depth.

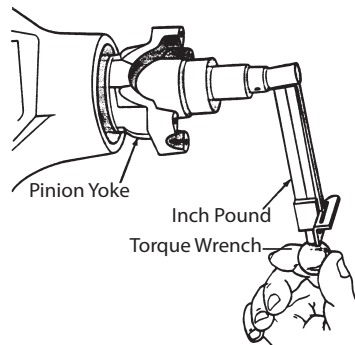

## A3 SAMPLE QUESTIONS (CONTINUED)

5. Which of these is the technician measuring in the illustration shown?

\* (A) Side gear clearance  
 (B) Ring gear runout  
 (C) Pinion depth  
 (D) Bearing preload

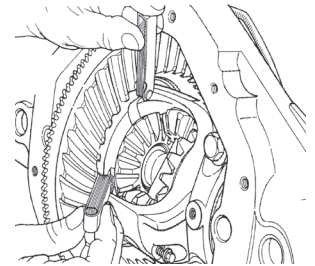

6. A four-wheel drive vehicle vibrates while the front axle is engaged. Technician A says that a failed rear axle shaft bearing could be the cause.

Technician B says that different front and rear tire diameters could be the cause.

Who is right?

(A) A only  
 \* (B) B only  
 (C) Both A and B  
 (D) Neither A nor B

7. A clutch chatters during engagement following a clutch replacement. Which of these could be the cause?

(A) An incorrect throw-out bearing  
 (B) A bent release fork  
 (C) Stiff clutch linkage  
 \* (D) Poor flywheel surface finish

***This question contains the word EXCEPT. Read the question carefully before choosing your answer.***

8. The clutch does not release fully when the pedal is pushed to the floor. Any of these could be the cause EXCEPT:

\* (A) weak pressure plate springs.  
 (B) too much free pedal travel.  
 (C) a warped clutch disc.  
 (D) a seized pilot bearing.



# TEST SPECIFICATIONS AND TASK LIST

## SUSPENSION AND STEERING (TEST A4)

Content Area	Questions in Test	Percentage of Test
A. Steering Systems Diagnosis and Repair	12	30%
B. Suspension Systems Diagnosis and Repair	12	30%
C. Wheel Alignment Diagnosis, Adjustment, and Repair	11	28%
D. Wheel and Tire Diagnosis and Service	5	12%
<b>Total</b>	<b>40</b>	<b>100%</b>

### A. Steering Systems Diagnosis and Repair (12 questions)

#### ► Steering Columns

1. Diagnose steering column noises and steering effort concerns (including manual and electronic tilt and telescoping mechanisms); determine needed action.
2. Inspect and replace steering column, steering shaft U-joint(s), flexible coupling(s), collapsible columns, intermediate shafts, and steering wheels (including steering wheels and columns equipped with airbags and/or other steering wheel/column mounted controls, sensors, and components).
3. Disable, enable, and properly handle airbag system components during vehicle service following manufacturers' procedures.
4. Diagnose, inspect, adjust, repair or replace components (including motors, sensors, switches, actuators, harnesses, and control units) of steering column-mounted, electronically controlled, hydraulically and/or electrically assisted steering systems; initialize systems as required.

#### ► Steering Units

5. Diagnose steering gear (non-rack and pinion type) noises, binding, vibration, freeplay, steering effort, steering pull (lead), and leakage concerns; determine needed action.
6. Diagnose rack and pinion steering gear noises, binding, vibration, freeplay, steering effort, steering pull (lead), and leakage concerns; determine needed action.
7. Inspect power steering fluid level and condition; determine fluid type and adjust fluid level in accordance with vehicle manufacturers' recommendations.
8. Inspect, adjust, align, and replace power steering pump belt(s), tensioners, and pulleys.

## A4 TASK LIST (CONTINUED)

9. Diagnose power steering pump noises, vibration, and fluid leakage; determine needed action.
10. Remove and replace power steering pump; inspect pump mounting and attaching brackets; remove and replace power steering pump pulley; transfer related components.
11. Perform power steering system pressure and flow tests; determine needed action.
12. Inspect and replace power steering hoses, fittings, O-rings, coolers, and filters.
13. Inspect steering gear (non-rack and pinion type) seals and gaskets; remove and replace steering gear.
14. Remove and replace rack and pinion steering gear; inspect mounting services; inspect and replace mounting bushings and brackets.
15. Adjust steering gear (non-rack and pinion type) worm bearing preload and sector lash.
16. Adjust rack and pinion steering gear.
17. Inspect and replace rack and pinion steering gear bellows/boots.
18. Flush, fill, and bleed power steering system.
19. Diagnose, inspect, repair or replace components of variable-assist and/or variable-ratio steering systems.
20. Diagnose, inspect, adjust, repair or replace components (including motors, sensors, switches, actuators, harnesses, and control units) of rack-mounted, electronically controlled, hydraulically and/or electrically assisted steering systems; initialize systems as required.

#### ► Steering Linkage

21. Inspect and adjust (where applicable) front and rear steering linkage geometry.
22. Inspect and replace pitman arm.
23. Inspect and replace center link (relay rod/drag link/intermediate rod).
24. Inspect, adjust (where applicable), and replace idler arm and mountings.
25. Inspect, replace, and adjust tie rods, tie rod sleeves/adjusters, clamps, and tie rod ends.
26. Inspect and replace steering linkage damper(s).

### B. Suspension Systems Diagnosis and Repair (12 questions)

#### ► Front Suspensions

1. Diagnose front suspension system noises, handling, ride height and ride quality concerns; determine needed action.
2. Inspect and replace upper and lower control arms, bushings, hardware, and shafts.
3. Inspect and replace rebound and jounce bumpers/bump stops.
4. Inspect, adjust, and replace track bar, strut rods/radius arms, and related mounts/bushings.
5. Inspect and replace upper and lower ball joints.
6. Inspect solid front axle assembly for damage and misalignment.
7. Inspect and replace front steering knuckle/spindle assemblies and steering arms.
8. Inspect and replace front suspension system coil springs and spring insulators (silencers).
9. Inspect and replace front strut(s), strut bearing(s) and strut mount(s).



---

## A4 TASK LIST (CONTINUED)

10. Inspect, replace, and adjust front suspension system torsion bars and mounts.
11. Inspect and replace front stabilizer bar (sway bar), bushings, brackets, and links.
12. Inspect and replace shock absorbers, mounts, and bushings.
13. Diagnose, service and/or replace front wheel bearings and/or hub assemblies.
14. Diagnose, inspect, adjust, repair or replace components (including sensors, switches, actuators, harnesses, and control units) of electrically/hydraulically/pneumatically controlled suspension systems (including primary and supplemental suspension and ride control systems); initialize as needed.
15. Inspect and repair front subframe/cradle/crossmember mountings, bushings, brackets, and bolts.

### ► Rear Suspensions

16. Diagnose rear suspension system noises, handling, ride height and ride quality concerns; determine needed action.
17. Inspect and replace rear suspension system coil springs and spring insulators (silencers).
18. Inspect and replace rear suspension system lateral links/arms (track bars), control (trailing) arms, stabilizer bars (sway bars), bushings, and mounts.
19. Inspect and replace rear suspension system leaf spring(s), leaf spring insulators (silencers), shackles, brackets, bushings, center pins/bolts, U-bolts, and mounts.
20. Inspect and replace rear rebound and jounce bumpers/bump stops.
21. Inspect and replace rear strut and/or upper strut mount.
22. Inspect non-independent rear axle assembly for damage and misalignment.
23. Inspect and replace rear ball joints and tie rod/toe link assemblies.
24. Inspect and replace rear knuckle/spindle assembly.
25. Inspect and replace shock absorbers, mounts, and bushings.
26. Diagnose, service, and/or replace rear wheel bearings and/or hub assemblies.
27. Diagnose, inspect, adjust, repair or replace components (including sensors, switches, actuators, harnesses, and control units) of electrically/hydraulically/pneumatically controlled suspension systems (including primary and supplemental suspension and ride control systems).
28. Inspect and repair rear subframe/cradle/crossmember mountings, bushings, brackets, and bolts.

### C. Wheel Alignment Diagnosis, Adjustment, and Repair (11 questions)

1. Diagnose vehicle wander, drift, pull, hard steering, bump steer, memory steer, torque steer, and steering return concerns; determine needed action.
2. Measure vehicle ride height; determine needed action.
3. Measure front and rear wheel camber; determine needed action.
4. Adjust front and/or rear wheel camber on suspension systems with a camber adjustment.
5. Measure caster; determine needed action.
6. Adjust caster on suspension systems with a caster adjustment.
7. Measure and adjust front wheel toe.
8. Center the steering wheel.
9. Measure toe-out-on-turns (turning radius/angle); determine needed action.
10. Measure SAI/KPI (steering axis inclination/king pin inclination); determine needed action.
11. Measure included angle; determine needed action.

---

## A4 TASK LIST (CONTINUED)

12. Measure rear wheel toe; determine needed action.
13. Measure thrust angle; determine needed action.
14. Measure wheelbase setback/offset; determine needed action.
15. Check front and/or rear subframe/cradle/crossmember alignment; determine needed action.
16. Perform electronic control module calibration/recalibration; perform initialization or relearn procedure as required.
17. Diagnose wheel alignment problems caused by damaged component mounting locations; determine needed action.

### D. Wheel and Tire Diagnosis and Service (5 questions)

1. Diagnose tire wear patterns; determine needed action.
2. Inspect tire condition, size, and application (load and speed ratings).
3. Measure and adjust tire air pressure.
4. Diagnose wheel/tire vibration, shimmy, and noise concerns; determine needed action.
5. Rotate tires/wheels and torque fasteners according to manufacturers' recommendations.
6. Diagnose problems with radial and lateral runout of wheel assembly; measure wheel, tire, axle flange, and hub runout (radial and lateral); determine needed action.
7. Diagnose tire pull (lead) problems; determine needed action.
8. Dismount and mount tire on wheel.
9. Balance wheel and tire assembly.
10. Test and diagnose indirect/direct tire pressure monitoring systems (TPMS); determine needed action; perform system initialization/relearn as required. ■

# SAMPLE QUESTIONS

## SUSPENSION AND STEERING (TEST A4)

- While traveling at highway speed, a vibration is felt in the steering wheel and the front end of the vehicle vibrates up and down. Which of these could be the cause?
  - (A) A leaking power steering rack
  - \* (B) Static out-of-balance of the front tires
  - (C) A binding ball joint
  - (D) Incorrect thrust angle
- The front end of a vehicle dives excessively while braking. Which of these could be the cause?
  - (A) Worn stabilizer bar bushings
  - (B) Worn power steering rack bushings
  - (C) A bent steering arm
  - \* (D) Weak springs

	SPECIFICATION	ACTUAL LEFT	ACTUAL RIGHT
<b>CASTER - FRONT</b>	0.00° +/- 0.25°	+0.25°	+0.00°
<b>CAMBER - FRONT</b>	0.50° +/- 0.50°	+0.50°	-0.75°
<b>CAMBER - REAR</b>	0.00° +/- 0.50°	0.00°	0.00°
<b>TOTAL TOE - FRONT</b>	0" +/- 1/32"	-1/8"	+1/16"
<b>TOTAL TOE - REAR</b>	0" +/- 1/32"	0"	0"

- A vehicle with the alignment readings shown has wear on the inside edge of the right front tire tread and pulls to the left. The cause could be incorrect:
  - (A) front caster.
  - \* (B) front camber.
  - (C) front toe.
  - (D) rear toe.

## A4 SAMPLE QUESTIONS (CONTINUED)

- A vehicle with rack and pinion steering has a shimmy. Technician A says that worn rack-to-frame mounting bushings could be the cause. Technician B says that a binding steering shaft U-joint could be the cause. Who is right?
  - \* (A) A only
  - (B) B only
  - (C) Both A and B
  - (D) Neither A nor B
- During a wheel alignment, a technician finds the toe-out-on-turns (turning radius) to be incorrect. The cause could be a bent:
  - (A) pitman arm.
  - (B) tie rod.
  - (C) idler arm.
  - \* (D) steering arm.
- A vehicle pulls to the right during braking. Technician A says that a worn control arm/strut rod bushing could be the cause. Technician B says that a bent right wheel could be the cause. Who is right?
  - \* (A) A only
  - (B) B only
  - (C) Both A and B
  - (D) Neither A nor B

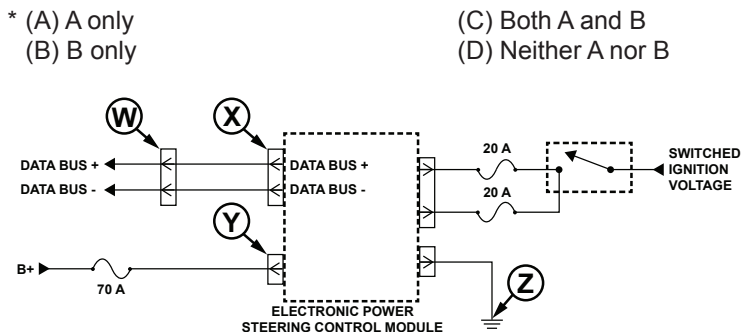

- A vehicle with the circuit shown has a stored "Electronic Power Steering Motor - Circuit Voltage Below Threshold" DTC. Which of these could be the cause?
  - (A) The data bus connector at W is open.
  - (B) The data bus wires are shorted together at X.
  - \* (C) There is high resistance in the connector at Y.
  - (D) There is an open circuit at Z.

## A4 SAMPLE QUESTIONS (CONTINUED)

8. A pressure test is being performed on a vehicle with power steering. The pressure readings taken when the wheels are at the right and left stops are below specification. The readings are normal when the tester shutoff valve is closed. Which of these could be the cause?

- \* (A) A failed steering gear
- (B) A failed power steering pump
- (C) A loose serpentine belt
- (D) A binding ball joint

9. Ball joint wear is being checked in the suspension shown.

Technician A says that the jack can be placed at X to perform the test.

Technician B says that the jack can be placed at Y to perform the test.

Who is right?

- (A) A only
- \* (B) B only
- (C) Both A and B
- (D) Neither A nor B

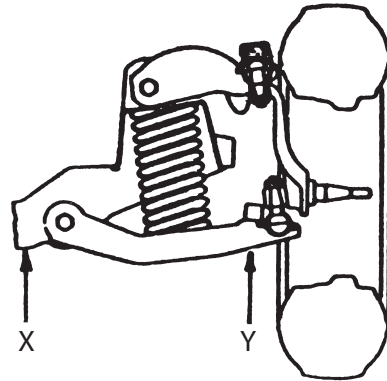

***This question contains the word EXCEPT. Read the question carefully before choosing your answer.***

10. Any of these could cause tire wear if not within manufacturer's specs EXCEPT:

- \* (A) caster.
- (B) wheel balance.
- (C) toe.
- (D) camber.

## TEST SPECIFICATIONS AND TASK LIST BRAKES (TEST A5)

Content Area	Questions in Test	Percentage of Test
A. Hydraulic, Power Assist, and Parking Brake Systems Diagnosis and Repair	19	43%
B. Drum Brake Diagnosis and Repair	5	11%
C. Disc Brake Diagnosis and Repair	11	24%
D. Electronic Brake Control Systems: Antilock Brake System (ABS), Traction Control System (TCS), and Electronic Stability Control System (ESC) Diagnosis and Repair	10	22%
<b>Total</b>	<b>45</b>	<b>100%</b>

### A. Hydraulic, Power Assist and Parking Brake Systems Diagnosis and Repair (19 questions)

#### ► Master Cylinder

1. Diagnose poor stopping, dragging, high or low pedal, and hard or spongy pedal caused by the master cylinder; determine needed repairs.
2. Measure and adjust master cylinder pushrod length.
3. Check master cylinder for failures by pressing brake pedal; determine needed repairs.
4. Diagnose the cause of master cylinder external fluid leakage.
5. Remove and replace master cylinder; bench bleed and install master cylinder; verify master cylinder function.

#### ► Lines and Hoses

6. Diagnose poor stopping, pulling or dragging caused by problems in the lines and hoses; determine needed repairs.
7. Inspect brake lines and fittings for leaks, dents, kinks, rust, cracks or wear; inspect for loose fittings and supports; determine needed repairs.
8. Inspect flexible brake hoses for leaks, kinks, cracks, bulging, wear or corrosion; inspect for loose fittings and supports; determine needed repairs.
9. Replace brake lines, hoses, fittings and supports; fabricate brake lines using proper material and flaring procedures (double flare and ISO types).
10. Inspect brake lines and hoses for proper routing and support.

---

## A5 TASK LIST (CONTINUED)

### ► Valves and Switches

11. Diagnose poor stopping, pulling or dragging caused by problems in the hydraulic system valve(s); determine needed repairs.
12. Inspect, test and replace metering, proportioning, pressure differential and combination valves.
13. Inspect, test, replace and adjust load or height sensing-type proportioning valve(s).
14. Inspect, test and replace brake system warning lights, indicators, switches, sensors and circuits; test, adjust and repair or replace brake stop light/brake pedal position switch sensor, lamps and related circuits.

### ► Bleeding, Flushing and Leak Testing

15. Diagnose poor stopping, pulling, dragging or incorrect pedal travel caused by problems in the brake fluid; determine needed repairs.
16. Bleed and/or flush hydraulic system using manual, pressure, vacuum or gravity method(s).
17. Pressure test brake hydraulic system.
18. Select, handle, store and install proper brake fluids (including silicone fluids). Fill master cylinder to proper level.

### ► Power Assist Units

19. Inspect and test brake pedal linkage for binding, looseness and adjustment; determine needed repairs.
20. Test pedal free travel with and without engine running to check power booster operation.
21. Check vacuum supply (manifold or auxiliary pump) to vacuum-type power booster.
22. Diagnose vacuum-type power booster unit for vacuum leaks and proper operation; inspect the check valve for proper operation; repair, adjust or replace parts as necessary.
23. Diagnose hydro-boost system for leaks and proper operation; repair or replace parts as necessary; refill and bleed system following manufacturers' specifications.
24. Diagnose electronic brake servo/brake simulator system for proper operation; determine needed repairs.

### ► Parking Brake

25. Diagnose parking brake system operation (including electronic parking brakes); inspect cables and parts for wear, rust and corrosion; clean or replace parts as necessary; lubricate assembly.
26. Adjust parking brake assembly; check operation.
27. Test the parking brake indicator light, switch and wiring.
28. Retract integral and/or electronic parking brake caliper piston(s) according to manufacturers' specifications.
29. Adjust calipers with integrated parking brakes according to manufacturers' recommendations.

### B. Drum Brake Diagnosis and Repair (5 questions)

1. Diagnose poor stopping, pulling, dragging or incorrect pedal travel caused by drum brake hydraulic problems; determine needed repairs.

---

## A5 TASK LIST (CONTINUED)

2. Diagnose poor stopping, noise, pulling, grabbing, dragging, pedal pulsation or incorrect pedal travel caused by drum brake mechanical problems; determine needed repairs.
3. Remove, clean, inspect and measure brake drums; follow manufacturers' recommendations in determining need to machine or replace.
4. Machine drums according to manufacturers' procedures and specifications.
5. Using proper safety procedures, remove, clean and inspect mechanical brake components, such as: shoes/linings, springs, pins, self-adjusters, levers, clips, brake backing (support) plates and other related brake hardware; determine needed repairs.
6. Lubricate brake shoe support pads on backing (support) plate, self-adjuster mechanisms and other brake hardware.
7. Inspect wheel cylinder(s) for leakage, operation and mounting; remove and replace wheel cylinder(s); bleed system.
8. Following manufacturers' specifications, install brake shoes and related hardware.
9. Preadjust brake shoes and parking brake before installing brake drums or drum/hub assemblies and wheel bearings.
10. Reinstall wheel, torque lug nuts, and make final checks and adjustments.
11. Diagnose wheel bearing noises and vibration problems; determine needed repairs.
12. Remove, clean, inspect, repack wheel bearings or replace wheel bearings and races; replace seals; replace hub and bearing assemblies; adjust wheel/hub bearings according to manufacturers' specifications.

### C. Disc Brake Diagnosis and Repair (11 questions)

1. Diagnose poor stopping, pulling, dragging or incorrect pedal travel caused by disc brake hydraulic problems; determine needed repairs.
2. Diagnose poor stopping, noise, pulling, grabbing, dragging, pedal pulsation or incorrect pedal travel caused by disc brake mechanical problems; determine needed repairs.
3. Retract brake caliper piston(s) according to manufacturers' recommendations.
4. Remove caliper assembly from mountings; inspect for leaks and damage to caliper housing.
5. Clean and inspect caliper mountings, slides/pins and threads for wear and damage.
6. Remove, clean and inspect pads and retaining hardware; determine needed repairs, adjustments and replacements.
7. Clean caliper assembly; inspect external parts for wear, rust, scoring and damage; replace any damaged or worn parts; determine the need to repair or replace caliper assembly.
8. Clean, inspect and measure rotor with a dial indicator and a micrometer; follow manufacturers' recommendations in determining the need to index, machine or replace the rotor.
9. Remove and replace rotor.
10. Machine rotor, using on-car or off-car method, according to manufacturers' procedures and specifications.
11. Install pads, calipers and related attaching hardware; lubricate components following manufacturers' procedures and specifications; bleed system and inspect for leaks.
12. Reinstall wheel, torque lug nuts, and make final checks and adjustments.

## A5 TASK LIST (CONTINUED)

- Road test vehicle and burnish/break-in pads according to manufacturer's recommendations.
- Diagnose wheel bearing noises and vibration problems; determine needed repairs.
- Remove, clean, inspect, repack wheel bearings or replace wheel bearings and races; replace seals; replace hub and bearing assemblies; adjust wheel/hub bearings according to manufacturers' specifications.
- Distinguish between brake component vibration and tire/wheel vibration; determine needed repairs.

### D. Electronic Brake Control Systems: Antilock Brake System (ABS), Traction Control System (TCS), and Electronic Stability Control System (ESC) Diagnosis and Repair (10 questions)

- Follow manufacturers' service and safety precautions when inspecting, testing and servicing electronic brake control system hydraulic, electrical, and mechanical components.
- Diagnose increased stopping distance, wheel lock-up, false activation, pedal feel, pedal travel, pedal pulsation and noise concerns associated with the electronic brake control system; determine needed repairs.
- Observe electronic brake control system indicator/light(s) at start-up and during road test; determine if further diagnosis is needed.
- Diagnose electronic brake control system, electronic control(s), components and circuits (with or without DTCs) using on-board diagnosis and/or recommended test equipment such as: scan tool, digital multimeter (DMM), digital storage oscilloscope (DSO); determine needed repairs.
- Bleed and/or flush the electronic brake control hydraulic system following manufacturers' procedures.
- Remove and install electronic brake control system components following manufacturers' procedures and specifications; perform module set-up/initialization.
- Test, diagnose and service electronic brake control system sensors (speed, yaw, steering angle, brake pedal position, etc.) and circuits following manufacturers' recommended procedures (includes output signal, resistance, amperage, shorts to voltage/ground and frequency data.).
- Diagnose electronic brake control system braking concerns caused by vehicle modifications (wheel/tire size, curb height, final drive ratio, etc.) and other vehicle mechanical and electrical/electronic modifications (communication, security, radio, etc.).
- Repair wiring harness and connectors following manufacturers' procedures.
- Diagnose brake problems resulting from failures of interrelated systems (for example: electronic stability control, antilock brake, traction control, collision avoidance/mitigation).
- Clear diagnostic trouble codes (DTCs) and verify the repair. ■

## SAMPLE QUESTIONS BRAKES (TEST A5)

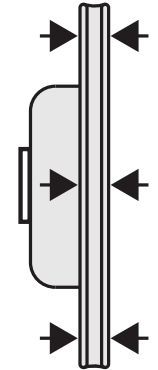

- Which of these could happen if the measurements in the set-up shown varied from manufacturer's specifications?
  - Noisy brake operation
  - Brake grab or pull
  - \* Pulsating brake pedal
  - (D) Low brake pedal
- The brake pedal on a vehicle with power-assisted disc/drum brakes moves slowly to the floor during braking. Which of these could be the cause?
  - \* (A) An internal master cylinder leak
  - (B) A leaking power brake booster diaphragm
  - (C) A leaking brake booster check valve
  - (D) An internal leak in the combination valve
- On a vehicle with disc/drum brakes, the front brakes grab quickly when light pedal pressure is applied. This could be caused by a failed:
  - (A) proportioning valve.
  - (B) pressure differential valve.
  - \* (C) metering valve.
  - (D) residual check valve.

### A5 SAMPLE QUESTIONS (CONTINUED)

4. On a vehicle with single piston, floating caliper disc brakes, the brake pad against the piston is badly worn. The other brake pad is only slightly worn.

Technician A says that too much rotor runout could be the cause.

Technician B says that a frozen caliper piston could be the cause.

Who is right?

- (A) A only  
(B) B only  
(C) Both A and B  
\* (D) Neither A nor B

5. When the brakes are applied, a vibration comes from the front of a vehicle with a disc/drum system. Which of these could be the cause?

- (A) Unequal tire pressure  
(B) Binding caliper slides  
\* (C) Excessive rotor runout  
(D) A frozen caliper piston

6. A front disc brake rotor is slightly below minimum thickness specification after machining. The technician should:

- (A) reuse the rotor.  
\* (B) replace the rotor.  
(C) apply a non-directional finish to the rotor.  
(D) machine the other front rotor to the same thickness.

7. A hydraulic brake line is leaking. Which of these is the correct repair?

- (A) Cut out the bad section and replace with new steel tubing using compression fittings.  
(B) Replace the leaking line with double-flared seamless aluminum tubing.  
(C) Cut out the bad section and replace with single-flared steel tubing using flare nuts and unions.  
\* (D) Replace the leaking line with double-flared steel tubing.

### A5 SAMPLE QUESTIONS (CONTINUED)

8. The set-up shown is used to check:

- (A) rotor parallelism.  
(B) wheel bearing adjustment.  
\* (C) rotor lateral runout.  
(D) rotor face wear.

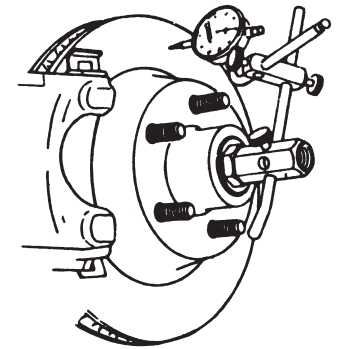

9. The drag on a vehicle's drum brakes increases after each application until they lock up. Bleeding the system restores normal operation for a short time; then drag increases until the brakes lock up again. Which of these could be the cause?

- \* (A) A failed master cylinder  
(B) A seized wheel caliper  
(C) Incorrect brake shoe adjustment  
(D) Weak brake shoe return springs

10. With the brakes applied, the pedal moves down slightly when the engine is started on a vehicle with power brakes.

Technician A says that a leaking power brake booster diaphragm could be the cause.

Technician B says that a stuck-closed brake booster vacuum check valve could be the cause.

Who is right?

- (A) A only  
(B) B only  
(C) Both A and B  
\* (D) Neither A nor B



# TEST SPECIFICATIONS AND TASK LIST

## ELECTRICAL/ELECTRONIC SYSTEMS (TEST A6)

Content Area	Questions in Test	Percentage of Test
A. General Electrical/Electronic System Diagnosis	13	26%
B. Battery and Starting System Diagnosis and Repair	9	18%
C. Charging System Diagnosis and Repair	5	10%
D. Lighting Systems Diagnosis and Repair	6	12%
E. Instrument Cluster and Driver Information Systems Diagnosis and Repair	6	12%
F. Body Electrical Systems Diagnosis and Repair	11	22%
<b>Total</b>	<b>50</b>	<b>100%</b>

### A. General Electrical/Electronic System Diagnosis (13 questions)

1. Check voltages and voltage drops in electrical/electronic circuits; interpret readings and determine needed repairs.
2. Check current flow in electrical/electronic circuits; interpret readings and determine needed repairs.
3. Check continuity and resistances in electrical/electronic circuits and components; interpret readings and determine needed repairs.
4. Check electronic circuit waveforms; interpret readings and determine needed repairs.
5. Use scan tool data, bidirectional controls, and/or diagnostic trouble codes (DTCs) to diagnose electronic systems; interpret readings and determine necessary action.
6. Find shorts, grounds, opens, and resistance problems in electrical/electronic circuits; determine needed repairs.
7. Measure and diagnose the cause(s) of abnormal key-off battery drain (parasitic draw); determine needed repairs.
8. Inspect, test, and replace fusible links, circuit breakers, fuses, diodes, and current limiting devices.
9. Read and interpret electrical schematic diagrams and symbols.
10. Research applicable vehicle and service information, such as vehicle service history, sevice precautions, technical service bulletins, and service campaigns/recalls.
11. Diagnose failures in the data bus communications network; determine needed repairs.
12. Remove and replace control modules; program, reprogram, code, initialize, and/or configure as needed.

## A6 TASK LIST (CONTINUED)

### B. Battery and Starting System Diagnosis and Repair (9 questions)

1. Perform battery state-of-charge test; determine needed service.
2. Perform battery tests (load and capacitance); determine needed service.
3. Follow manufacturer's procedure to restore (or maintain if applicable) electronic memory functions.
4. Perform battery charge in accordance with manufacturer's recommendations.
5. Inspect, clean, repair and/or replace battery(ies), battery cables, connectors, clamps, hold-downs, trays, and vent tubes.
6. Jump-start a vehicle using jumper cables, a booster battery or auxiliary power supply.
7. Perform starter current draw test; determine needed repairs.
8. Perform starter circuit voltage drop tests; determine needed repairs.
9. Inspect, test, repair and/or replace starter, relays, solenoids, modules, switches, connectors, and wires of starter circuits.
10. Differentiate between electrical and engine mechanical problems that cause a slow crank, no-crank, extended cranking, or a cranking noise condition.

### C. Charging System Diagnosis and Repair (5 questions)

1. Diagnose charging system problems that cause a no-charge, a low charge, or an overcharge condition; determine needed repairs.
2. Inspect, reinstall and/or replace pulleys, tensioners and drive belts; adjust belts and check alignment.
3. Perform charging system voltage output test; determine needed repairs.
4. Perform charging system current output test; determine needed repairs.
5. Inspect and test generator (alternator) control components including sensors, regulators, and modules; determine needed repairs.
6. Perform charging circuit voltage drop tests; determine needed repairs.
7. Inspect, test, repair and/or replace connectors, terminals, and wires of charging system circuits.
8. Remove, inspect, and replace generator (alternator).

### D. Lighting Systems Diagnosis and Repair (6 questions)

1. Diagnose the cause of brighter than normal, intermittent, dim, continuous or no operation of exterior lighting; determine needed repairs.
2. Inspect, replace, aim and/or level headlight assemblies and auxiliary light assemblies (fog lights/driving lights), including high-intensity discharge (HID) and LED systems.
3. Inspect, test, repair and/or replace switches, relays, bulbs, LEDs, sockets, connectors, terminals, wires, and control modules of exterior lighting.
4. Diagnose the cause of turn signal and/or hazard light system malfunctions; determine needed repairs.
5. Inspect, test, repair and/or replace switches, flasher units, bulbs, sockets, connectors, terminals, wires, and control modules of turn signal and hazard light circuits.
6. Diagnose the cause of intermittent, dim, continuous or no operation of interior lighting circuits (such as: courtesy, dome, map, vanity, glove box, cargo, trunk, hood, instrument, and accent lighting); determine needed repairs.
7. Inspect, test, repair and/or replace switches, relays, bulbs, sockets, connectors, terminals, wires, and control modules of interior lighting circuits (such as: courtesy, dome, map, vanity, glove box, cargo, trunk, hood, instrument, and accent lighting).

## A6 TASK LIST (CONTINUED)

8. Inspect, test, repair and/or replace trailer wiring harness, relays, connectors, and control modules (including brake control).

### E. Instrument Cluster and Driver Information Systems Diagnosis and Repair (6 questions)

1. Diagnose the cause of intermittent, dim, no lights, continuous operation, or no brightness control of instrument lighting circuits; determine needed repairs.
2. Inspect, test, repair and/or replace switches, relays, bulbs, LEDs, sockets, connectors, terminals, wires, and control modules of instrument lighting circuits.
3. Diagnose the cause of high, low, intermittent, or no readings on electronic instrument cluster gauges; determine needed repairs.
4. Diagnose the cause of constant, intermittent, or no operation of warning lights, indicator lights, audible warning devices, and other driver information systems; determine needed repairs.
5. Inspect, test, repair and/or replace bulbs, sockets, connectors, terminals, switches, relays, sensors, timers, wires, gauges, sending units, electronic components, and control modules of electronic instrument clusters and driver information system circuits.

### F. Body Electrical Systems Diagnosis and Repair (11 questions)

1. Diagnose operation of comfort and convenience accessories and related circuits (such as: power windows, power seats, adjustable pedal height, power locks, trunk locks, remote start, moon roof, sunroof, sun shade, keyless entry, voice activation, phone pairing technology, wireless connectivity, steering wheel controls, camera systems, park assist, cruise control, and automated exterior lighting); determine needed repairs.
2. Inspect, test, repair and/or replace components, connectors, terminals, and wiring of comfort and convenience accessories.
3. Diagnose operation of heated and cooled accessories and related circuits (such as: heated/cooled seats, heated steering wheel, heated mirror, heated glass, and heated/cooled cup holders); determine needed repairs.
4. Inspect, test, repair and/or replace components, connectors, terminals, and wiring of heated and cooled accessories.
5. Diagnose operation of security/anti-theft systems and related circuits (such as: theft deterrent, door locks, keyless entry, remote start, and starter/fuel disable); determine needed repairs.
6. Inspect, test, repair and/or replace components, connectors, terminals, and wiring of security/anti-theft systems.
7. Diagnose operation of entertainment/infotainment and related circuits (such as: radio, DVD, navigation, amplifiers, speakers, antennas, and voice-activated accessories); determine needed repairs.
8. Inspect, test, repair and/or replace components, connectors, terminals, and wiring of entertainment/infotainment systems.
9. Diagnose operation of safety systems and related circuits (such as: supplemental restraint systems, wipers, washers, horn, speed control, collision avoidance, telematics, heads-up display, park assist, and camera systems); determine needed repairs.
10. Inspect, test, repair and/or replace components, connectors, terminals, and wiring of safety systems. ■

## SAMPLE QUESTIONS ELECTRICAL/ELECTRONIC SYSTEMS (TEST A6)

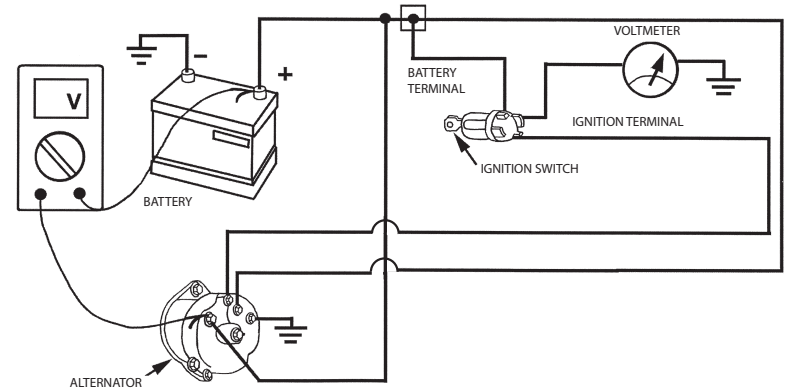

1. In the charging system shown, with the engine running, the digital multimeter (DMM) will display:  
(A) charging output voltage.  
(B) regulator operating voltage.  
\* (C) charging circuit voltage drop  
(D) ignition switch voltage drop.
2. The oil pressure light stays on whenever the engine is running. The oil pressure has been checked and is at specification. Technician A says that a ground in the circuit between the indicator light and the pressure switch could be the cause. Technician B says that an open in the pressure switch could be the cause. Who is right?  
\* (A) A only  
(B) B only  
(C) Both A and B  
(D) Neither A nor B
3. The passenger side power window operates properly when using the passenger side control switch, but the window will operate in the DOWN position only when using the driver's side master control switch. Which of these could be the cause?  
(A) A pinched wire from the passenger side control switch to the window motor  
(B) An open wire to the driver's side window motor  
(C) A grounded power wire to the power window circuit breaker  
\* (D) An open circuit in the driver's side master control switch

## A6 SAMPLE QUESTIONS (CONTINUED)

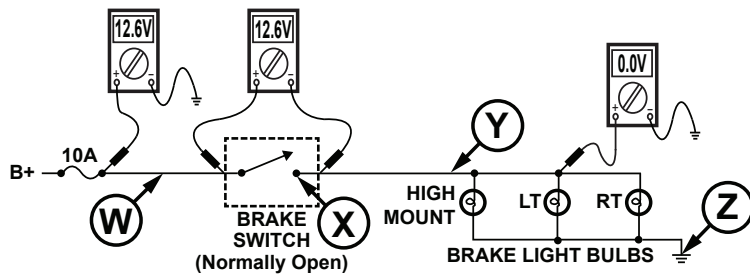

4. The brake lights are not working on the vehicle with the circuit shown. With the brake pedal pressed, the technician observes the DMM readings shown. Which of these could be the cause?
- (A) High resistance at W  
 \* (B) An open circuit at X  
 (C) A short-to-ground at Y  
 (D) An open circuit at Z
5. Technician A says that if a fusible link in the alternator charging circuit is replaced with system sized wire, the circuit will be unprotected.
- Technician B says that if a fusible link in the alternator charging circuit is replaced with system sized wire, the battery will overcharge.

Who is right?

- \* (A) A only  
 (B) B only  
 (C) Both A and B  
 (D) Neither A nor B
6. A starter solenoid clicks but the starter does not crank the engine.
- Technician A says that burned solenoid contacts could be the cause.
- Technician B says that a poor battery cable connection could be the cause.
- Who is right?
- (A) A only  
 (B) B only  
 \* (C) Both A and B  
 (D) Neither A nor B

## A6 SAMPLE QUESTIONS (CONTINUED)

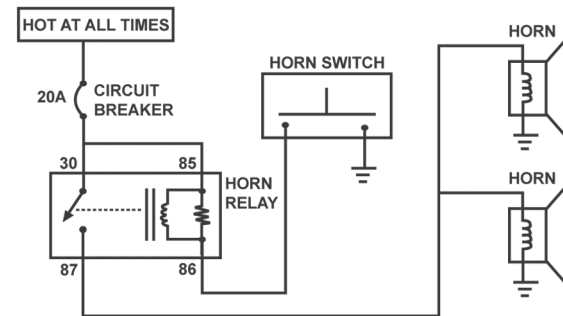

7. The horns in the circuit shown operate only when a jumper wire is connected between terminals 30 and 87 of the horn relay.
- Technician A says that a failed horn relay could be the cause.
- Technician B says that a short-to-ground in the circuit between the horn relay and the horn switch could be the cause.
- Who is right?
- \* (A) A only  
 (B) B only  
 (C) Both A and B  
 (D) Neither A nor B
8. Which of these digital multimeter (DMM) readings indicates a current flow of 3 amps in a circuit?
- (A) 300 microamps  
 (B) 3.0 milliamps  
 \* (C) 3000 milliamps  
 (D) 0.3 amps

***This question contains the word EXCEPT. Read the question carefully before choosing your answer.***

9. Any of these could cause high starter current draw EXCEPT:
- (A) worn starter bushings.  
 \* (B) a failed starter relay.  
 (C) grounded field coils.  
 (D) a seized A/C compressor.

# TEST SPECIFICATIONS AND TASK LIST

## HEATING AND AIR CONDITIONING (TEST A7)

**Note: ASE HVAC certifications (A7, T7, H7 or S7) do not provide the necessary credentials to satisfy EPA requirements for Section 609 refrigerant management. The ASE Refrigerant Recovery and Recycling Review and Quiz program meets Section 609 requirements and can be taken online and in print. Details are at [www.ase.com/cfc](http://www.ase.com/cfc).**

Content Area	Questions in Test	Percentage of Test
A. Heating, Ventilation, A/C (HVAC) and Engine Cooling System Service, Diagnosis, and Repair	21	42%
B. Refrigeration System Component Diagnosis and Repair	10	20%
C. Operating Systems and Related Controls Diagnosis and Repair	19	38%
<b>Total</b>	<b>50</b>	<b>100%</b>

### A. Heating, Ventilation, A/C (HVAC) and Engine Cooling System Service, Diagnosis, and Repair (21 questions)

1. Identify system type and conduct performance test on the A/C system; determine needed repairs.
2. Diagnose A/C system problems indicated by system pressures and/or temperature readings; determine needed repairs.
3. Diagnose A/C system problems indicated by sight, sound, smell, and touch procedures; determine needed repairs.
4. Leak test A/C system; determine needed repairs.
5. Identify A/C system refrigerant and existing charge amount; recover refrigerant.
6. Evacuate A/C system.
7. Inspect A/C system components for contamination; determine needed repairs.
8. Charge A/C system with refrigerant.
9. Identify A/C system lubricant type and capacity; replenish lubricant if necessary.
10. Inspect and replace passenger compartment (cabin air, pollen) filter.
11. Disarm and enable the airbag system for vehicle service following manufacturers' recommended procedures.
12. Read diagnostic trouble codes (DTCs) and interpret scan tool data stream.
13. Read and interpret technical literature (service publications, bulletins, recalls, and information including wiring schematics).
14. Use a scan tool, digital multimeter (DMM), or digital storage oscilloscope (DSO) to test HVAC system sensors, actuators, circuits, and control modules; determine needed repairs.
15. Verify proper operation of certified equipment.

## A7 TASK LIST (CONTINUED)

16. Recycle or properly dispose of refrigerant.
17. Label and store refrigerant.
18. Test refrigerant cylinders for non-condensable gases; identify refrigerant.
19. Identify the procedures and equipment necessary to service, diagnose, and repair A/C systems in hybrid/electric vehicles.
20. Diagnose the cause of temperature control problems in the heater/ventilation system; determine needed repairs.
21. Diagnose window fogging problems; determine needed repairs.
22. Perform engine cooling system tests (flow, pressure, electrolysis, concentration, and contamination); determine needed repairs.
23. Inspect and replace engine coolant hoses and pipes.
24. Inspect, test, and replace radiator, pressure cap, coolant recovery system, and water pump.
25. Inspect, test, and replace thermostat, thermostat by pass, and housing.
26. Identify, inspect, recover coolant; flush and refill system with proper coolant; bleed system as necessary.
27. Inspect, test, and replace fan (both electrical and mechanical), fan clutch, fan belts, fan shroud, and air dams.
28. Inspect, test, and replace heater coolant control valve (manual, vacuum, and electrical types), and auxiliary coolant pump.
29. Inspect, flush, and replace heater core.

### B. Refrigeration System Component Diagnosis and Repair (10 questions)

#### ► Compressor and Clutch

1. Diagnose A/C system problems that cause the protection devices (pressure, thermal, and electronic controls) to interrupt system operation; determine needed repairs.
2. Inspect, test, and replace A/C system pressure, thermal, and electronic protection devices.
3. Inspect, adjust, and replace A/C compressor drive belts, pulleys, and tensioners.
4. Inspect, test, service, and replace A/C compressor clutch components or assembly.
5. Identify required lubricant type; inspect and correct level in A/C compressor.
6. Inspect, test, service or replace A/C compressor, mounting, and fasteners.

#### ► Evaporator, Condenser, and Related Components

7. Inspect, repair, or replace A/C system mufflers, hoses, lines, filters, fittings, and seals.
8. Inspect A/C condenser for proper air flow.
9. Inspect, test, and clean or replace A/C system condenser; check mountings and air seals.
10. Inspect and replace receiver/drier, accumulator/drier, or desiccant.
11. Inspect, test, and replace expansion valve(s).
12. Inspect and replace orifice tube(s).
13. Inspect A/C evaporator for proper air flow.
14. Inspect, test, clean, or replace evaporator(s).
15. Inspect, clean and repair evaporator housing, and water drain.
16. Inspect, test, and replace evaporator pressure/temperature control systems and devices.
17. Identify, inspect, and replace A/C system service valves and valve caps.
18. Inspect and replace A/C system high pressure relief device.

## A7 TASK LIST (CONTINUED)

### C. Operating Systems and Related Controls Diagnosis and Repair (19 questions)

#### ► Electrical

1. Diagnose the cause of failures in the electrical control system of heating, ventilating, and A/C (HVAC) systems; determine needed repairs.
2. Inspect, test, repair, and replace HVAC heater blower motors, blower motor speed controls, resistors, switches, relays/modules, wiring, and protection devices.
3. Inspect, test, repair, and replace A/C compressor clutch coil, relay/ modules, wiring, sensors, switches, diodes, and protection devices.
4. Inspect, test, repair, and replace A/C-related powertrain control systems and components.
5. Inspect, test, repair, and replace load sensitive A/C compressor cut-off systems.
6. Inspect, test, repair, and replace engine cooling/condenser fan motors, relays/ modules, switches, sensors, wiring, and protection devices.
7. Inspect, test, adjust, repair and replace climate control system electric actuator motors, relays/ modules, switches, sensors, wiring, and protection devices (including dual/multi-zone systems).
8. Inspect, test, service, or replace HVAC panel assemblies.

#### ► Vacuum/Mechanical

9. Diagnose the cause of failures of the heating, ventilating, and A/C (HVAC) vacuum and mechanical control systems; determine needed repairs.
10. Inspect, test, service, or replace HVAC control panel assemblies.
11. Inspect, test, adjust, and replace HVAC control cables and linkages.
12. Inspect, test, and replace HVAC vacuum system actuators (diaphragms/motors), hoses, reservoir, check valve, and restrictors.
13. Inspect, test, adjust, repair, or replace HVAC ducts, doors, and outlets (including dual/multi-zone systems).

#### ► Automatic and Semi-Automatic Heating, Ventilating, and A/C Systems

14. Diagnose temperature control system problems; determine needed repairs (including dual/multi-zone systems).
15. Diagnose blower system problems; determine needed repairs (including dual/multi-zone systems).
16. Diagnose air distribution system problems; determine needed repairs (including dual/multi-zone systems).
17. Diagnose compressor clutch control system; determine needed repairs.
18. Inspect, test, or replace climate and blower control sensors.
19. Inspect, test, and replace door actuator(s).
20. Inspect, test, and replace heater coolant control valve and controls.
21. Inspect, test, and replace electric and vacuum motors, solenoids, and switches.
22. Inspect, test, or replace Automatic Temperature Control (ATC) control panel and/or climate control computer/module; program, code, or initialize as required.
23. Check and adjust calibration of Automatic Temperature Control (ATC) system.
24. Diagnose data communication issues, including diagnostic trouble codes (DTCs) that affect climate control system operation. ■

## SAMPLE QUESTIONS

### HEATING AND AIR CONDITIONING (TEST A7)

1. Prior to recovery, an unknown refrigerant is identified. The technician should:  
(A) discharge it into the atmosphere.  
\* (B) recover it and treat it as contaminated.  
(C) recover it and recycle it as R-12.  
(D) recover it and recycle it as R-134a.
2. A vehicle with automatic temperature control blows hot air on HIGH fan speed from the dash vents with the temperature set to 72° F. Which of these could be the cause?  
(A) A shorted blower motor resistor  
(B) A restricted receiver/drier  
(C) A weak serpentine belt tensioner  
\* (D) An open duct temperature sensor

3. Technician A says that evacuating an A/C system will remove air and moisture from the system.

Technician B says that evacuating an A/C system will remove dirt particles from the system.

Who is right?

- \* (A) A only  
(B) B only  
(C) Both A and B  
(D) Neither A nor B

4. The blower motor in the schematic shown works only with the blower switch in the # 4 position. This could be caused by a failed:

- (A) blower motor.  
(B) blower motor ground.  
(C) blower motor relay.  
\* (D) blower motor resistor.

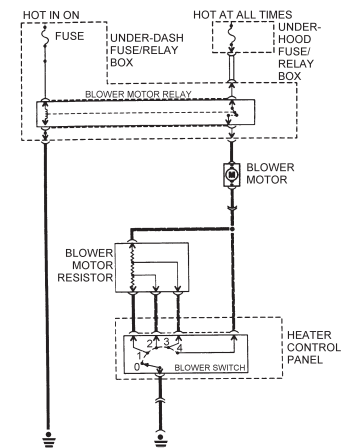



## A7 SAMPLE QUESTIONS (CONTINUED)

5. To charge an A/C system while it is running, the refrigerant should be added to:
- (A) the high side only.
  - \* (B) the low side only.
  - (C) both the high and the low sides.
  - (D) either the high or the low side.
6. With the A/C system operating at an ambient (outside) temperature of 85° F, the low pressure gauge reads 5 psi and the high pressure gauge reads 105 psi. What do these readings indicate?
- (A) Normal operation
  - \* (B) Low refrigerant level
  - (C) A restriction in the high side
  - (D) Broken compressor reed valves
7. With a DMM connected between the battery negative terminal and the A/C clutch coil positive terminal, the DMM measures 14.2 volts, but the A/C clutch will not engage.
- Technician A says that a failed clutch coil could be the cause.
- Technician B says that a failed clutch coil diode could be the cause.
- Who is right?
- \* (A) A only
  - (B) B only
  - (C) Both A and B
  - (D) Neither A nor B

***This question contains the word EXCEPT. Read the question carefully before choosing your answer.***

8. The high-side pressure in an A/C system is above specs. Any of these could be the cause EXCEPT:
- (A) an overcharge of refrigerant.
  - (B) a restricted air flow across the condenser.
  - (C) a plugged expansion valve.
  - \* (D) a broken compressor reed valve.

## TEST SPECIFICATIONS AND TASK LIST ENGINE PERFORMANCE (TEST A8)

Content Area	Questions in Test	Percentage of Test
A. General Diagnosis	12	24%
B. Ignition System Diagnosis and Repair	8	16%
C. Fuel, Air Induction and Exhaust Systems Diagnosis and Repair	9	18%
D. Emission Control Systems Diagnosis and Repair	8	16%
1. Positive Crankcase Ventilation (1)		
2. Exhaust Gas Recirculation (2)		
3. Secondary Air Injection (AIR) and Catalytic Converter (2)		
4. Evaporative Emissions Controls (3)		
E. Computerized Engine Controls Diagnosis and Repair	13	26%
<b>Total</b>	<b>50</b>	<b>100%</b>

### A. General Diagnosis (12 questions)

1. Verify driver's complaint, perform visual inspection, and/or road test vehicle; determine needed action.
2. Research applicable vehicle and service information, such as engine management system operation, vehicle service history, service precautions, technical service bulletins, and service campaigns/recalls.
3. Diagnose noises and/or vibration problems related to engine performance; determine needed action.
4. Diagnose the cause of unusual exhaust color, odor, and sound; determine needed action.
5. Perform engine manifold vacuum or pressure tests; determine needed action.
6. Perform cylinder power balance test; determine needed action.
7. Perform cylinder cranking, relative, and running compression tests; interpret test results; determine needed action.
8. Perform cylinder leakage/leak-down test; determine needed action.
9. Diagnose engine mechanical, electrical, electronic, fuel, and ignition problems with an oscilloscope, engine analyzer, and/or scan tool; determine needed action.



---

## A8 TASK LIST (CONTINUED)

10. Prepare and inspect vehicle for HC, CO, NO<sub>x</sub>, CO<sub>2</sub>, and O<sub>2</sub> exhaust gas analysis; perform test and interpret exhaust gas readings.
11. Verify valve adjustment on engines with mechanical or hydraulic lifters.
12. Verify camshaft timing; verify operation of camshaft timing components, including engines equipped with variable valve timing; determine needed action.
13. Diagnose emissions or driveability problems caused by oil related issues, such as incorrect pressure, poor quality, incorrect level, or incorrect type used for the application.
14. Verify engine operating temperature, check coolant level and condition, perform cooling system pressure test; determine needed action.
15. Inspect and test mechanically/hydraulically/electronically operated fans, fan clutch, fan shroud/ducting, and fan control devices; determine needed action.
16. Read and interpret electrical schematic diagrams and symbols.
17. Test and diagnose emissions or driveability problems caused by battery condition, connections, or excessive key-off battery drain; determine needed action.
18. Perform starter current draw test; determine needed action.
19. Perform starter and charging circuit voltage drop tests; determine needed action.
20. Test and diagnose engine performance problems resulting from charging system failures; determine needed action.
21. Inspect, adjust, and replace alternator (generator) drive belts, pulleys, clutches, tensioners and/or fans.
22. Inspect, test, and repair or replace system components, connectors and wires in the starter and charging control circuits.

### B. Ignition System Diagnosis and Repair (8 questions)

1. Diagnose ignition system related problems such as no-starting, hard starting, engine misfire, poor driveability, spark knock, power loss, poor mileage, and emissions problems; determine root cause; determine needed action.
2. Interpret ignition system related diagnostic trouble codes (DTCs); determine needed action.
3. Inspect, test, repair, or replace ignition primary circuit wiring and components.
4. Inspect, test, service, repair or replace ignition system secondary circuit wiring and components.
5. Inspect, test, and replace ignition coil(s).
6. Inspect, test, and replace ignition system sensors; adjust as necessary.
7. Inspect, test, and/or replace ignition control module (ICM) and/or powertrain/engine control module (PCM/ECM); reprogram/initialize as needed.

### C. Fuel, Air Induction and Exhaust System Diagnosis and Repair (9 questions)

*NOTE: Fuel Injection system diagnosis and repair will include vehicles equipped with either multiport or gasoline direct injection (GDI) systems. These systems may be either speed density (based on rpm and MAP) or mass airflow (MAF). When appropriate, the fuel system type will be identified in the ASE test question.*

1. Diagnose fuel system related problems, including hot or cold no-starting, hard starting, poor driveability, incorrect idle speed, poor idle, flooding, hesitation, surging, engine misfire, power loss, stalling, poor mileage, and emissions problems; determine root cause; determine needed action.

---

## A8 TASK LIST (CONTINUED)

2. Interpret fuel or induction system related diagnostic trouble codes (DTCs); analyze fuel trim and other scan tool data; determine needed action.
3. Inspect fuel tank, filler neck, and gas cap; inspect and replace fuel lines, fittings, and hoses; determine needed action.
4. Inspect, test, and replace fuel pump(s) and/or fuel pump assembly; inspect, service, and replace fuel filters.
5. Inspect and test fuel pump control circuits and components; determine needed action.
6. Inspect, test, and repair or replace fuel pressure regulation system and components of fuel injection systems; check fuel for contaminants and quality; perform fuel pressure/volume test.
7. Inspect, test, service and/or replace throttle assembly; make related adjustments and/or perform initialization or relearn procedure as required.
8. Inspect, test, clean, and replace fuel injectors and fuel rails.
9. Inspect, service, and repair or replace air filtration system components.
10. Inspect throttle assembly, air induction system, intake manifold and gaskets for air/vacuum leaks, restrictions and/or unmetered air.
11. Remove, clean, inspect, test, and repair or replace fuel system vacuum and electrical components and connections.
12. Inspect, service, and replace exhaust manifold, exhaust pipes, oxygen sensors, air/fuel ratio sensors, mufflers, catalytic converters, resonators, tailpipes, and heat shields.
13. Test for exhaust system restriction or leaks; determine needed action.
14. Inspect, test, clean and repair or replace turbocharger or supercharger and system components.

### D. Emission Control Systems Diagnosis and Repair (8 questions)

#### 1. Positive Crankcase Ventilation (1 question)

1. Test and diagnose emissions or driveability problems caused by positive crankcase ventilation (PCV) system.
2. Inspect, service, and replace positive crankcase ventilation (PCV) filter/breather cap, valve, oil separator tubes, orifice/metering device, and hoses.

#### 2. Exhaust Gas Recirculation (2 questions)

1. Test and diagnose driveability problems caused by the exhaust gas recirculation (EGR) system.
2. Interpret exhaust gas recirculation (EGR) related scan tool data and diagnostic trouble codes (DTCs); determine needed action.
3. Inspect, test, service, and replace components of the EGR system, including EGR valve, tubing, passages, vacuum/pressure controls, filters, hoses, electrical/electronic sensors, controls, solenoids and wiring of exhaust gas recirculation (EGR) systems.

#### 3. Secondary Air Injection (AIR) and Catalytic Converter (2 questions)

1. Test and diagnose emissions or driveability problems caused by the secondary air injection or catalytic converter systems.
2. Interpret secondary air injection system related scan tool data and diagnostic trouble codes (DTCs); determine needed action.
3. Inspect, test, service, and replace mechanical components and electrical/electronic components and circuits of secondary air injection systems.

## A8 TASK LIST (CONTINUED)

4. Inspect catalytic converter. Interpret catalytic converter related diagnostic trouble codes (DTCs); analyze related scan tool data to determine root cause of DTCs; determine needed action.

### 4. Evaporative Emissions Controls (3 questions)

1. Test and diagnose emissions or driveability problems caused by the evaporative emissions control (EVAP) system.
2. Interpret evaporative emissions-related scan tool data and diagnostic trouble codes (DTCs); determine needed action.
3. Inspect, test, and replace canister, lines/hoses, filters, mechanical and electrical components of the evaporative emissions control (EVAP) system.

### E. Computerized Engine Controls Diagnosis and Repair (13 questions)

1. Retrieve and record diagnostic trouble codes (DTCs), OBD II monitor status and freeze frame data.
2. Diagnose the causes of emissions or driveability problems with stored or active diagnostic trouble codes (DTCs).
3. Diagnose the causes of emissions or driveability problems without diagnostic trouble codes (DTCs).
4. Use a scan tool, digital multimeter (DMM), or digital storage oscilloscope (DSO) to inspect or test computerized engine control system sensors, actuators, circuits, and powertrain/engine control module (PCM/ECM); determine needed action.
5. Measure and interpret voltage, voltage drop, amperage, and resistance using digital multimeter (DMM) readings.
6. Test, remove, inspect, clean, service, and repair or replace power and ground distribution circuits and connections.
7. Inspect, test, and/or replace the powertrain/engine control module (PCM/ECM); reprogram/initialize as needed.
8. Diagnose driveability and emissions problems resulting from failures of interrelated systems (for example: cruise control, security alarms/theft deterrent, torque management, traction controls, A/C, non-OEM installed accessories).
9. Clear diagnostic trouble codes (DTCs), run all OBD II monitors, and verify the repair. ■

## SAMPLE QUESTIONS ENGINE PERFORMANCE (TEST A8)

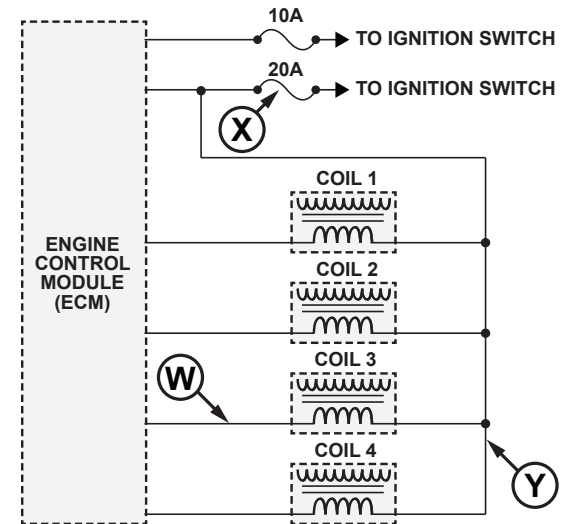

1. An engine equipped with the ignition system shown idles smoothly but misfires on acceleration. Which of these could be the cause?

- \* (A) High resistance at W
- (B) An open fuse at X
- (C) A short-to-ground at Y
- (D) An open crankshaft position sensor circuit

2. While the engine is running, a technician pulls the PCV valve out of the valve cover and plugs the valve opening. There are no changes in engine operation.

Technician A says that the PCV valve could be stuck in the open position.

Technician B says that the hose between the intake manifold and the PCV valve could be plugged.

Who is right?

- (A) A only
- (B) B only
- (C) Both A and B
- (D) Neither A nor B

A8 SAMPLE QUESTIONS (CONTINUED)

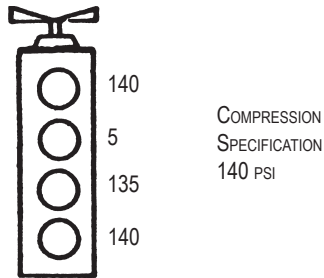

3. After the compression readings shown in the illustration were taken, a wet compression test was made. The second set of readings was almost the same as the first. Technician A says that a burned valve could cause these readings. Technician B says that a broken piston ring could cause these readings. Who is right?

\* (A) A only (C) Both A and B  
(B) B only (D) Neither A nor B

4. Blue smoke comes from the exhaust pipe of a vehicle. Technician A says that blocked cylinder head oil return passages could be the cause. Technician B says that a stuck-open engine thermostat could be the cause. Who is right?

\* (A) A only (C) Both A and B  
(B) B only (D) Neither A nor B

5. A vehicle is being diagnosed for poor fuel economy. Engine tests show a rich exhaust gas mixture. Technician A says that a failed oxygen (O<sub>2</sub>) sensor could be the cause. Technician B says that a failed engine coolant temperature sensor could be the cause. Who is right?

(A) A only \* (C) Both A and B  
(B) B only (D) Neither A nor B

A8 SAMPLE QUESTIONS (CONTINUED)

6. A vacuum gauge is connected to the intake manifold of an engine. With the engine running at 2,000 rpm, the pointer on the gauge fluctuates rapidly between 10 and 22 in.Hg. The cause could be:

(A) a leaking intake manifold gasket.  
(B) worn piston rings.  
(C) worn valve guides.  
\* (D) a broken valve spring.

7. The technician finds no spark and no injector pulses on a vehicle that will not start. The cause could be a failed:

(A) mass airflow sensor (MAF).  
\* (B) crankshaft position (CKP) sensor.  
(C) throttle position sensor (TPS).  
(D) fuel pump (FP) module.

8. An engine with a return-type electronic fuel injection (EFI) system has high fuel pressure at idle. Which of these could be the cause?

\* (A) Low manifold vacuum  
(B) A leaking fuel pump check valve  
(C) A plugged fuel injector  
(D) High manifold vacuum

9. Which of these could cause a catalytic converter to overheat?

(A) A broken air pump drive belt  
(B) A plugged canister purge vacuum hose  
(C) A stuck-closed EGR valve  
\* (D) A disconnected spark plug wire

***This question contains the word EXCEPT. Read the question carefully before choosing your answer.***

10. Any of these could cause an "Exhaust Gas Recirculation (EGR) - Insufficient Flow Detected" DTC EXCEPT:

(A) an exhaust leak.  
\* (B) a stuck-open EGR valve.  
(C) a restricted EGR port.  
(D) an electrically open EGR solenoid.

# TEST SPECIFICATIONS AND TASK LIST

## LIGHT VEHICLE DIESEL ENGINES (TEST A9)

Content Area	Questions in Test	Percentage of Test
A. General Diagnosis	9	18%
B. Cylinder Head and Valve Train Diagnosis and Repair	5	10%
C. Engine Block Diagnosis and Repair	5	10%
D. Lubrication and Cooling Systems Diagnosis and Repair	6	12%
E. Air Induction and Exhaust Systems Diagnosis and Repair	12	24%
F. Fuel System Diagnosis and Repair	13	26%
<b>Total</b>	<b>50</b>	<b>100%</b>

### A. General Diagnosis (9 questions)

1. Verify the complaint, and road/dyno test vehicle; review driver/customer concerns/expectations and vehicle service history (if available); determine further diagnosis.
2. Record vehicle identification number (VIN). Identify engine model, calibration and serial numbers to research applicable vehicle and service information, service precautions, and technical service bulletins; determine needed actions.
3. Perform scan tool check and visual inspection for physical damage and missing, modified, or tampered components; determine needed actions.
4. Check and record electronic diagnostic codes, freeze frame and/or operational data; monitor scan tool data; determine further diagnosis.
5. Clear diagnostic trouble codes (DTCs) and verify the repair.
6. Inspect engine assembly and compartment for fuel, oil, coolant, exhaust, or other leaks; determine needed repairs.
7. Inspect engine compartment wiring harness, connectors, seals, and locks; check for proper routing and condition; determine needed repairs.
8. Listen for and isolate engine noises; determine needed repairs.
9. Isolate and diagnose engine related vibration problems; determine needed actions.
10. Check engine exhaust for abnormal odor and/or smoke color and volume; determine further diagnosis.
11. Check fuel for contamination, quantity, quality, and consumption; determine needed actions.
12. Perform crankcase pressure test; determine further diagnosis.
13. Diagnose surging, rough operation, misfiring, low power, slow deceleration, slow acceleration, and shutdown problems; determine needed actions.
14. Check cooling system for freeze point, level, contamination, condition, temperature, pressure, circulation, and fan operation; determine needed repairs.

### A9 TASK LIST (CONTINUED)

15. Check lubrication system for contamination, oil level, temperature, pressure, filtration, and oil consumption; take oil sample and obtain oil analysis if needed; determine needed repairs.
16. Diagnose no-cranking, cranks but fails to start, hard starting, and starts but does not continue to run problems; determine needed actions.
17. Diagnose engine problems caused by battery condition, connections, or excessive key-off battery drain; determine needed repairs.
18. Diagnose engine problems resulting from an electrical undercharge, overcharge, or a no-charge condition; determine needed action.

### B. Cylinder Head and Valve Train Diagnosis and Repair (5 questions)

1. Remove, inspect, disassemble, and clean cylinder head assembly(s).
2. Inspect threaded holes, studs, and bolts for serviceability; service/replace as needed.
3. Measure cylinder head thickness, and check mating surfaces for flatness, corrosion, warpage and surface finish; inspect for cracks/damage; check condition of passages; inspect core and gallery plugs; determine serviceability and needed repairs.
4. Inspect valves, guides, seats, springs, retainers, rotators, locks and seals; determine serviceability and needed repairs.
5. Inspect and/or replace injector sleeves, glow plug sleeves, and seals; pressure test to verify repair (if applicable); measure injector tip, nozzle, or prechamber protrusion where specified by manufacturer.
6. Inspect, and/or replace valve bridges (crossheads) and guides; adjust bridges (crossheads) if applicable.
7. Reassemble, check, and determine required cylinder head gasket thickness; install cylinder head assembly and gasket as specified by the manufacturer.
8. Inspect pushrods, rocker arms, rocker arm shafts, electronic components, wiring harness, seals; repair/replace as needed.
9. Inspect, install, and adjust cam followers, lash adjusters and retainers; adjust valve clearance if applicable.
10. Inspect, measure, and replace/reinstall overhead camshaft and bearings; measure and adjust endplay.
11. Inspect and time drive gear train components (includes gear, chain, and belt systems).

### C. Engine Block Diagnosis and Repair (5 questions)

1. Remove, inspect, service, and install pans, covers, ventilation systems, gaskets, seals, and wear rings.
2. Disassemble, clean and inspect engine block for cracks; check mating surfaces and related components for damage or warpage and surface finish; check deck height; check condition of passages, core, and gallery plugs; inspect threaded holes, studs, dowel pins and bolts for serviceability; service/replace as needed.
3. Inspect and measure cylinder walls for wear and damage; determine needed service.
4. Inspect in-block camshaft bearings for wear and damage; replace as needed.
5. Inspect, measure, and replace/reinstall in-block camshaft; measure and correct end play; inspect, replace/reinstall, and adjust cam followers (if applicable).
6. Clean and inspect crankshaft and journals for surface finish, cracks, and damage; check condition of oil passages; check passage plugs; measure journal diameters; check mounting surfaces; determine needed service.

---

## A9 TASK LIST (CONTINUED)

7. Determine the proper select-fit components such as pistons, connecting rod and main bearings.
8. Inspect and replace main bearings; check cap fit and bearing clearances; check and correct crankshaft end play.
9. Inspect, replace, verify, and adjust the drive gear train components (includes gear, chain, and belt systems).
10. Inspect, measure, or replace pistons, pins, and retainers.
11. Measure piston-to-cylinder wall clearance.
12. Identify piston, connecting rod bearing, and main bearing wear patterns that indicate connecting rod and crankshaft alignment or bearing bore problems; check bearing bore and bushing condition; determine needed repairs.
13. Check ring-to-groove fit and end gaps; install rings on pistons; assemble pistons and connecting rods and install in block; check piston height/protrusion; check liner height/protrusion (if applicable); replace rod bearings and check clearances; check condition, position, and clearance of piston cooling jets (nozzles).
14. Inspect crankshaft vibration damper; determine needed repairs.
15. Inspect flywheel/flexplate and/or dual-mass flywheel (including ring gear) and mounting surfaces for cracks, wear, and runout; determine needed repairs.

### D. Lubrication and Cooling Systems Diagnosis and Repair (6 questions)

1. Verify base engine oil pressure and check operation of pressure sensor/switch and pressure gauge; verify engine oil temperature and check operation of temperature sensor.
2. Inspect, measure, repair/replace oil pump, housing, drives, pipes, and screens; check drive gear clearance.
3. Inspect, repair/replace oil pressure regulator assembly including: housing, bore, spring, regulator valve(s), oil filter by-pass valve(s), and anti-drain back valve.
4. Inspect, clean, test, and reinstall/replace oil cooler, by-pass valve, lines, and hoses.
5. Inspect turbocharger lubrication and cooling systems; repair/replace as needed.
6. Change engine oil and filters using proper type, viscosity, and rating per manufacturer specifications.
7. Inspect and reinstall/replace pulleys, tensioners, and drive belts; adjust drive belts and check alignment.
8. Verify coolant temperature; check operation of temperature and level sensors, switches, and temperature gauge.
9. Inspect and replace thermostat(s), by-pass(es), housing(s), and seal(s).
10. Flush and refill cooling system; following manufacturer's specification, add proper coolant type; bleed air from system.
11. Inspect and replace water pump(s), housing(s), hoses, and idler pulley(s) or drive gear.
12. Inspect radiator(s), pressure cap(s), and tank(s); pressure test cooling system and radiator cap(s); determine needed repairs.
13. Inspect and repair/replace cooling fan, fan hub, fan clutch, controls, and shroud(s).

---

## A9 TASK LIST (CONTINUED)

### E. Air Induction and Exhaust Systems Diagnosis and Repair (12 questions)

1. Inspect and service/replace air induction piping, air cleaner, and element; determine needed actions.
2. Perform intake manifold pressure tests; inspect, test, clean, and/or replace charge air cooler and piping system; determine needed actions.
3. Inspect test, and replace turbocharger(s) (including variable ratio/geometry VGT), pneumatic, hydraulic, vacuum, and electronic controls and actuators; inspect, test, and replace wastegate and wastegate controls.
4. Inspect, test, and replace intake manifold(s), variable intake manifold(s), gaskets, actuators, temperature and pressure sensors, and connections.
5. Perform exhaust back pressure and temperature tests; determine needed actions.
6. Inspect and repair/replace exhaust manifold(s), gaskets, piping, mufflers, and mounting hardware.
7. Inspect, test, and repair/replace preheater/inlet air heater and/or glow plug system and controls.
8. Inspect, test, and replace exhaust aftertreatment system components and controls, including diesel oxidation catalyst (DOC), selective catalyst reduction (SCR), diesel exhaust fluid (DEF), diesel particulate filter (DPF); check regeneration system operation.
9. Inspect, test, service, and replace EGR system components including EGR valve(s), EGR cooler by-pass valve(s), EGR cooler(s), piping, electronic sensors, actuators, controls, and wiring.
10. Inspect, test, and replace airflow control (throttle) valve(s) and controls.
11. Inspect, test, and replace crankcase ventilation system components, including sensors, filters, valves, and piping.

### F. Fuel System Diagnosis and Repair (13 questions)

1. Inspect, clean, test, and repair/replace fuel system tanks, vents, caps, mounts, valves, single/dual supply and return lines, and fittings.
2. Inspect, clean, test, and repair/replace fuel transfer and/or supply pump, sensors, strainers, fuel/water separators/indicators, filters, heaters, coolers, ECM cooling plates (if applicable), and mounting hardware.
3. Check fuel system for air; determine needed repairs; prime and bleed fuel system; check and repair/replace primer pump.
4. Inspect, test, and repair/replace low fuel pressure regulator supply and return systems, including low pressure switches.
5. Inspect and reinstall/replace high-pressure injection lines, fittings, transfer tubes, seals, and mounting hardware.
6. Inspect, adjust, and repair/replace electronic throttle and PTO control devices, circuits, and sensors.
7. Perform on-engine inspections, tests, and replace high pressure common rail fuel system components and electronic controls.
8. Perform on-engine inspections and tests; replace hydraulic electronic unit injector(s) (HEUI) components and electronic controls.
9. Perform on-engine inspections and tests; replace pump-line-nozzle fuel system (PLN-E) components and electronic controls.



10. Perform on-engine inspections and tests; replace electronic unit injector(s) (EUI) components and electronic controls.
11. Inspect and replace electrical connector terminals, pins, harnesses, seals, and locks.
12. Connect diagnostic scan tool to vehicle/engine; access, verify and update software calibration settings, injector calibration codes; perform control module re-learn procedures as needed.
13. Use a diagnostic scan tool to inspect and test electronic engine control system, sensors, actuators, electronic control modules, and circuits; determine further diagnosis.
14. Measure and interpret voltage, voltage drop, amperage, and resistance readings using a digital multimeter (DMM) or appropriate test equipment.
15. Diagnose engine problems resulting from failures of interrelated systems (for example: cruise control, security alarms/theft deterrent, transmission controls, exhaust aftertreatment systems, electronic stability control, or non-OEM installed accessories). ■

## SAMPLE QUESTIONS

### LIGHT VEHICLE DIESEL ENGINES (TEST A9)

1. An electronic diesel engine has an active diagnostic trouble code (DTC) for "Cylinder #3 Misfire" detected. This could be caused by:
  - \* (A) low compression in the #3 cylinder.
  - (B) an open #3 cylinder glow plug.
  - (C) a shorted #3 cylinder glow plug.
  - (D) an incorrect fuel cetane rating.
  
2. A vehicle has low power under load. Which of these could be the cause?
  - \* (A) A leaking charge air cooler
  - (B) A leak in the turbocharger inlet piping
  - (C) Using an off road grade of fuel
  - (D) An open in the mass airflow sensor circuit
  
3. A vehicle equipped with a HEUI fuel system is hard to start at engine temperatures lower than 35° F (1.7° C).  
 Technician A says that worn injectors could be the cause.  
 Technician B says that an open glow plug could be the cause.  
 Who is right?
  - \* (A) A only
  - (B) B only
  - (C) Both A and B
  - (D) Neither A nor B
  
4. Technician A says that the vanes in a variable geometry turbo (VGT) system are closed at wide open throttle (WOT).  
 Technician B says that sticking vanes in a variable geometry turbo (VGT) system can be determined by observing the MAF sensor voltage readings on a scan tool.  
 Who is right?
  - (A) A only
  - (B) B only
  - (C) Both A and B
  - \* (D) Neither A nor B



## A9 SAMPLE QUESTIONS (CONTINUED)

5. An electronic fuel injector on a diesel engine with a high-pressure common rail injection system is being replaced. The information at point Y in the illustration shown indicates the injector:

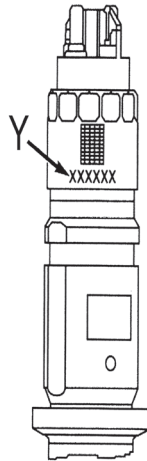

- (A) bar code.
- (B) maximum pressure rating.
- (C) opening pressure.
- \* (D) calibration coding.

***This question contains the word EXCEPT. Read the question carefully before choosing your answer.***

6. A diesel engine has a serious vibration at idle. Any of these could be the cause EXCEPT:
- (A) a broken motor mount.
  - (B) misfiring cylinders.
  - (C) an incorrect idle speed.
  - \* (D) a stuck-closed EGR valve.
7. A high pressure common rail (HPCR) equipped diesel engine is being diagnosed for a crank/no-start concern. During testing, a manual gauge is installed and low fuel rail pressure is observed. Which of these could be the cause?
- (A) A restricted injector tip
  - (B) An open injector control circuit
  - (C) An open fuel rail pressure sensor circuit
  - \* (D) A failed fuel rail pressure control valve

## TEST SPECIFICATIONS AND TASK LIST AUTOMOBILE SERVICE CONSULTANT (TEST C1)

Content Area	Questions in Test	Percentage of Test
A. Communications	23	46%
B. Product Knowledge	18	36%
C. Shop Operations	9	18%
<b>Total</b>	<b>50</b>	<b>100%</b>

### A. Communications (23 questions)

#### ► Customer Relations

1. Demonstrate professional telephone skills.
2. Obtain, confirm, and document pertinent vehicle/customer contact information.
3. Communicate with customer and document customer concern/request.
4. Demonstrate professional greeting skills/acknowledgement.
5. Discuss alternative transportation options.
6. Promote procedures, benefits, and capabilities of service facility.
7. Review vehicle service history.
8. Identify and communicate recommended service and maintenance needs.
9. Establish vehicle status/completion expectations.
10. Confirm accuracy of the repair order and obtain repair/service authorization.
11. Identify customer type (first time, warranty, repeat repair, fleet, etc.) and source of payment as necessary.
12. Present professional image.
13. Perform customer follow-up.
14. Explain and confirm invoice accuracy, understanding of work performed or declined charges, and warranties.
15. Handle customer complaints.

#### ► Sales Skills

16. Provide and explain estimates.
17. Identify and prioritize vehicle needs and/or service recommendations.
18. Address original concerns with customer.
19. Communicate the value of related and additional services.
20. Communicate product/service features and benefits.
21. Overcome objections/finalize sale.

---

## C1 TASK LIST (CONTINUED)

### B. Product Knowledge (18 questions)

#### ► Engine Systems (Includes Computer Controls, Mechanical, Cooling, Fuel, Ignition, Exhaust, Emissions Control, and Starting/Charging)

1. Identify major components and location.
2. Identify the basic function of major components.
3. Identify related items

#### ► Drive Train Systems (Includes Computer Controls, Manual Transmission/Transaxles, Automatic Transmission/Transaxles, and Drive Train Components)

4. Identify major components and location.
5. Identify component function.
6. Identify related items.

#### ► Chassis Systems (Includes Computer Controls, Frames, Brakes, ABS, Traction Control, Suspension, Steering, Wheels, Tires, and TPMS)

7. Identify major components and location.
8. Identify component function.
9. Identify related items.

#### ► Body Systems (Includes Computer Controls, Body Components, Glass, Heating and Air Conditioning, Electrical, Restraint and Accessories)

10. Identify major components and location.
11. Identify component function.
12. Identify related items.

#### ► Services/Maintenance Intervals

13. Understand the elements of a maintenance procedure.
14. Identify and communicate related maintenance, reset and follow up procedures.
15. Locate and interpret maintenance schedule information.

#### ► Warranty, Service Contracts, Service Bulletins, and Campaigns/Recalls

16. Demonstrate knowledge of warranty policies, procedures, and parameters.
17. Locate and use reference information for warranties, service contracts, service bulletins, and campaigns/recalls.
18. Demonstrate general knowledge of service contracts, technical service bulletins, campaigns and recalls.
19. Determine the application of warranty, service contracts, and campaigns/recalls.

#### ► Vehicle Identification

20. Locate and utilize vehicle ID number (VIN).
21. Locate production date.
22. Locate and utilize component identification data.
23. Identify body styles.

### C. Shop Operations (9 questions)

1. Manage work flow.
2. Demonstrate knowledge of sublet procedures.
3. Maintain customer appointment log.

---

## C1 TASK LIST (CONTINUED)

4. Address repeat repairs/comebacks.
5. Manage after hours vehicles.

#### ► Internal Relations

6. Effectively communicate customer service concern/request.
7. Understand the technician's diagnosis and service recommendations.
8. Verify availability of parts.
9. Establish completion expectations.
10. Monitor repair/service progress.
11. Document information about recommended services performed or declined.
12. Communicate with shop personnel about shop production/efficiency and repair/service quality.
13. Maintain open lines of communication within the organization. ■

---

## SAMPLE QUESTIONS

### AUTOMOBILE SERVICE CONSULTANT (TEST C1)

1. A customer is concerned about brake noise on their vehicle. The service consultant should:
  - (A) explain that brake noise is common on all vehicles.
  - (B) ask the customer to imitate the noise.
  - \* (C) explain that a technician will need to evaluate the vehicle.
  - (D) give the customer an average price for a brake job.
  
2. A customer comes in for a 30,000 mile service. While completing the service, the technician notes that the vehicle will soon need the front brake pads replaced. Which of these is the best way to address this need with the customer?
  - (A) Note the technician's comments on the customer's repair order.
  - (B) Input the technician's comments in the dealership's database for review at the next service
  - \* (C) Call the customer and offer to complete the repair explaining why it is needed.
  - (D) Address the need when the customer arrives to pick up their vehicle.
  
3. The service consultant is talking to a customer on the telephone when another customer comes to the service desk. How should the service consultant proceed?
  - (A) Acknowledge the new customer after finishing the phone call.
  - \* (B) Acknowledge the new customer while continuing the phone call.
  - (C) Ask the customer to call back later.
  - (D) Put the caller on hold and help the new customer.
  
4. Which of these should a service consultant do when a customer objects to a recommended service or repair?
  - \* (A) Ask additional questions to determine the cause of their objection.
  - (B) Discount the repair to satisfy the customer.
  - (C) Offer less expensive parts to reduce the cost.
  - (D) Offer to review how the technician diagnosed the vehicle.

---

### C1 SAMPLE QUESTIONS (CONTINUED)

5. Which of these functions is performed by the engine timing belt?
    - (A) It connects the pistons to the crankshaft.
    - (B) It can be used to adjust spark timing.
    - \* (C) It drives the camshaft.
    - (D) It controls engine rpm.
  
  6. A vehicle's ABS light remains on while driving. Service Consultant A says that while the light is ON, the ABS system will still function. Service Consultant B says that while the light is ON, the mechanical brake system will still function. Who is right?
    - (A) A only
    - \* (B) B only
    - (C) Both A and B
    - (D) Neither A nor B
  
  7. Which of these represents a sublet procedure?
    - (A) On-car brake rotor machining
    - (B) Sending the customer to a glass specialist
    - (C) Installing a remanufactured transmission
    - \* (D) Sending a flywheel to be resurfaced
- This question contains the word EXCEPT. Read the question carefully before choosing your answer.***
8. Any of these are acceptable sources to consult for a specific vehicle maintenance schedule EXCEPT:
    - (A) vehicle owner's manual.
    - (B) shop reference manuals.
    - \* (C) vehicle's emission label.
    - (D) electronic information system.

# TEST SPECIFICATIONS AND TASK LIST

## COMPRESSED NATURAL GAS VEHICLE (TEST F1)

Content Area	Questions in Test	Percentage of Test
A. Pre-Service Vehicle Inspection	5	9%
B. CNG System Equipment Inspection	8	15%
C. Leak Testing and Repairs	6	11%
D. Emissions and Performance Verification	11	20%
E. System Diagnosis, Maintenance, and Repair	16	29%
F. General Cylinder Safety and Maintenance	9	16%
<b>Total</b>	<b>55</b>	<b>100%</b>

**Note:** All CNG vehicle testing, service, and repair should be performed using vehicle and component manufacturer's guidelines and current NFPA 52 and/or local safety standards.

### A. Pre-Service Vehicle Inspection (5 questions)

1. Inspect vehicle integrity including serviceability, alterations, and applicable emissions and safety standards..
2. Analyze vehicle/system performance; determine needed actions.
3. Inspect CNG cylinder(s) condition and expiration/end-of-life date; inspect CNG cylinder(s) shields/covers and determine needed actions.
4. Inspect for proper mounting of compressed natural gas cylinders and fuel system components.
5. Inspect for location, condition and compliance of venting system(s).

### B. CNG System Equipment Inspection (8 questions)

1. Inspect fuel storage cylinders and system components.
2. Inspect fuel storage system brackets, isolators, reinforcements, and fasteners.
3. Inspect regulator assembly(ies) and coolant lines.
4. Inspect underhood fuel delivery system components.
5. Inspect system wiring.
6. Inspect electrical and electronic components.
7. Inspect fuel system gauges.
8. Inspect fuel lines, clamps, filters, and fittings.
9. Inspect valves, pressure-relief devices, venting systems, lines, fittings, and fasteners.
10. Inspect fuel fill receptacle(s) and check valve(s).
11. Verify/inspect required labels.

## F1 TASK LIST (CONTINUED)

12. Complete system documentation as required.
13. Inspect defueling receptacle as required.

### C. Leak Testing and Repairs (6 questions)

1. Check for low- and high-pressure system leaks; repair as needed.
2. Pressurize cylinders with CNG.
3. Check for coolant leaks; repair as needed.
4. Check venting system integrity; repair as needed.

### D. Emissions and Performance Verification (11 questions)

1. Check regulator(s) pressure(s); determine needed repair.
2. Verify control module(s) (ECM/PCM) calibration.
3. Check operation of electronic components.
4. Check operation of fuel gauge; determine needed repairs.
5. Perform emission tests; make repairs and document where applicable.
6. Road test vehicle for acceptable driveability; check starting/restarting abilities.
7. Check manual and automatic fuel changeover operation (bi-fuel vehicles).
8. Check fuel system for abnormal noises.
9. Verify gaseous fuel management operation.

### E. System Diagnosis, Maintenance, and Repair (16 questions)

**Note:** The following tasks apply to both bi-fuel and dedicated CNG vehicles.

1. Interpret and verify operational complaint; determine needed repair.
2. Visually inspect gaseous fuel system components; determine needed repairs.
3. Retrieve and interpret Diagnostic Trouble Codes (DTC) using appropriate diagnostic equipment/scan tool.
4. Diagnose driveability and emissions problems related to the ignition system; determine needed repairs.
5. Diagnose driveability and emissions problems related to fuel and air induction systems and exhaust systems; determine needed repairs.
6. Diagnose driveability and emissions problems related to electronic engine controls; determine needed repairs.
7. Check vacuum/electrical/electronic component operation; determine needed repairs.
8. Check gaseous fuel delivery system pressures and component operation; determine needed repairs.
9. Remove and/or replace fuel lines, manual and electrical valves, fittings, and pressure relief devices.
10. Defuel CNG system.
11. Check for signs of fuel contamination; inspect, replace and/or service fuel system filters as required.

### F. General Cylinder Safety and Maintenance (9 questions)

1. Visually inspect fuel storage cylinder(s), shields, and mounting.
2. Remove and replace cylinders; defuel according to recommended procedures; replace shields, brackets, and hardware as required.
3. Handle and store cylinders in accordance with recommended procedures.

---

## F1 TASK LIST (CONTINUED)

4. Interpret cylinder label information; determine necessary action.
5. Inspect pressure relief devices (PRD) and related hardware; determine necessary action.
6. Inspect condition and operation of cylinders/tank valves; determine necessary action.
7. Decommission cylinders according to recommended procedures. ■

---

## SAMPLE QUESTIONS

### COMPRESSED NATURAL GAS VEHICLE (TEST F1)

1. The ignition firing voltage on a bi-fuel vehicle is being checked. During testing, a technician observes the voltage is higher when operating on CNG as compared to operating on gasoline. Which of these could be the cause?
  - \* (A) The air/fuel mixture is leaner when operating on CNG.
  - (B) The air/fuel mixture is richer when operating on CNG.
  - (C) The air/fuel mixture is leaner when operating on gasoline.
  - (D) The air/fuel mixture is richer when operating on gasoline.
2. Which of these should be used to check the fuel line connections after a compressed natural gas system repair?
  - (A) Nitrogen
  - (B) Propane
  - \* (C) Non-ammonia soap
  - (D) Carbon dioxide
3. After installing a new CNG fuel tank, the technician finds that the vehicle will not accept fuel. Which of these could be the cause?
  - (A) A pinched O-ring on the receptacle line
  - \* (B) A failure to open the manual lock-down valve(s)
  - (C) An open circuit on the in-tank solenoid valve
  - (D) A short-to-ground in the solenoid wiring harness
4. A hoop-wrapped Type-2 cylinder shows evidence of stress corrosion cracking. What should the technician do?
  - (A) Nothing, stress corrosion cracking is normal
  - (B) Repair the area using an approved coating
  - (C) Note the damage on the inspection form
  - \* (D) Remove the cylinder from service

F1 SAMPLE QUESTIONS (CONTINUED)

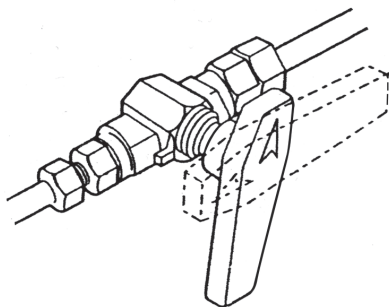

5. A bi-fuel vehicle with the valve shown is in for a routine coalescent filter change. Technician A says that the valve should be closed to stop gasoline flow to the engine. Technician B says that the valve should be closed to stop CNG flow from the tank. Who is right?
- (A) A only
  - \* (B) B only
  - (C) Both A and B
  - (D) Neither A nor B

***This question contains the word EXCEPT. Read the question carefully before choosing your answer.***

6. A dedicated CNG vehicle has a no-start condition. All of these could be the cause EXCEPT:
- (A) no ignition source.
  - \* (B) high-ethanol gasoline.
  - (C) no fuel pressure.
  - (D) low battery voltage.

## TEST SPECIFICATIONS AND TASK LIST EXHAUST SYSTEMS (TEST X1)

Content Area	Questions in Test	Percentage of Test
A. Exhaust System Inspection and Repair	11	28%
1. Inspection (6)		
2. Repair (5)		
B. Emissions Systems Diagnosis	8	20%
C. Exhaust System Fabrication	6	15%
1. Pipe Bending (3)		
2. Welding and Cutting (3)		
D. Exhaust System Installation	8	20%
E. Exhaust System Repair Regulations	7	18%
<b>Total</b>	<b>40</b>	<b>100%</b>

### A. Exhaust System Inspection and Repair (11 questions)

#### 1. Inspection (6 questions)

1. Inspect all exhaust system components for noises, rattles, missing parts, configuration, routing and integrity by visual, audible, and thump testing; determine needed repair.
2. Inspect exhaust system for leaks, restrictions, and overheating by visual, audible, back pressure, vacuum, and temperature testing; determine needed repair.
3. Inspect exhaust subsystems [air injection reactor (AIR), exhaust gas recirculation (EGR), oxygen sensor(s) (O2S/HO2S), air/fuel ratio (AFR) sensor(s), turbochargers] and mounting hardware; determine needed repair.
4. Identify emission systems configuration using the emissions label; visually inspect exhaust system for evidence of tampering (missing/modified and/or improperly installed components); determine needed repair.
5. Inspect exhaust system electrical components; determine needed repair.
6. Inspect engine/transmission mount condition and alignment; determine needed repair.

#### 2. Repair (5 questions)

1. Repair or replace failed or damaged mufflers, pipes, and related components.
2. Repair or replace damaged catalytic converters.
3. Repair or replace exhaust manifolds.



---

## X1 TASK LIST (CONTINUED)

4. Repair or replace exhaust system mounting hardware and related installation components.
5. Repair or replace exhaust subsystems [air injection reactor (AIR), exhaust gas recirculation (EGR), oxygen sensor (O2S/HO2S), air/fuel ratio (AFR) sensor(s), turbochargers] and mounting hardware.

### B. Emissions Systems Diagnosis (8 questions)

1. Identify failed catalytic converter(s); determine cause of failure; determine needed repair.
2. Identify failed air injection reactor (AIR) system; determine cause of failure; determine needed repair.
3. Identify failed exhaust gas recirculation (EGR) system; determine cause of failure; determine needed repair.
4. Identify failed air/fuel ratio (AFR) sensor(s) and oxygen sensor(s)(O2S/HO2S) component(s) and circuitry; determine cause of failure; determine needed repair.
5. Inspect emission systems for evidence of tampering (missing/modified and/or improperly installed component) based on the configuration identified on the emission label; determine needed repair.

### C. Exhaust System Fabrication (6 questions)

#### 1. Pipe Bending (3 questions)

1. Determine bending method (program card, pattern/copy, or custom).
2. Determine center of bends, rotation of pipe, depth of bends, and pipe diameter(s); perform bending operation.
3. Perform end-forming/flaring and hardware installation operations.
4. Determine the cause of pipe material failures that occur during bending operations.

#### 2. Welding and Cutting (3 questions)

1. Select appropriate welding method (gas or MIG); perform welding operation; verify integrity of weld.
2. Set up and adjust welding equipment to repair application; observe applicable personnel, vehicle, and equipment safety procedures.
3. Select appropriate cutting method (gas or mechanical); perform cutting operation.
4. Set up and adjust cutting equipment to repair application; observe applicable personnel, vehicle, and equipment safety procedures.

### D. Exhaust System Installation (8 questions)

1. Identify exhaust system configuration and options according to manufacturer's specifications (routing, single/dual, etc).
2. Select components according to accepted standards regarding material, type, design, and size.
3. Install appropriate exhaust system components (mufflers, resonators, catalytic converters, pipes, and manifolds).
4. Install appropriate exhaust system hardware (clamps, hangers, gaskets, flanges, fasteners, and heat shields).
5. Inspect system for proper exhaust component clearance and routing.

---

## X1 TASK LIST (CONTINUED)

6. Inspect system for proper exhaust component-to-component connection sealing.
7. Install exhaust subsystem components [air injection reactor (AIR), exhaust gas recirculation (EGR) valve, oxygen sensor(s) (O2S/HO2S), air/fuel ratio (AFR) sensor(s)].

### E. Exhaust System Repair Regulations (7 questions)

*Note: Federal EPA law establishes minimum compliance requirements for emission systems repair. States and local municipalities may institute requirements that exceed the Federal EPA requirements. Knowledge of the Federal EPA requirements will be addressed in the following tasks.*

1. Comply with warranty and diagnostic requirements regarding permissible catalytic converter installations.
2. Comply with requirements regarding prohibited catalytic converter installations.
3. Comply with requirements regarding record keeping.
4. Comply with requirements regarding catalytic converter replacement, location, and type.
5. Comply with requirements regarding replacement of air injection reactor (AIR), exhaust gas recirculations (EGR), oxygen sensor (O2S/HO2S), air/fuel ratio (AFR) sensor, and turbocharger systems.
6. Comply with requirements regarding exhaust system configuration. ■

---

## SAMPLE QUESTIONS

### EXHAUST SYSTEMS (TEST X1)

1. Which of these could cause an exhaust manifold gasket to fail?  
(A) A failed AIR pump  
\* (B) A restricted exhaust system  
(C) An inoperative converter  
(D) A failed EGR valve
2. Which of these repairs should be made on a vehicle with a cracked catalytic converter flange?  
\* (A) Repair or replace the flange.  
(B) Replace the converter with a test pipe.  
(C) Replace the lead pipe.  
(D) Seal and clamp the connection.
3. A visual inspection of a vehicle's catalytic converter reveals that the substrate (brick) has melted.  
Technician A says that a failed air/fuel ratio (AFR) sensor could be the cause.  
Technician B says that a misfiring spark plug could be the cause.  
Who is right?  
(A) A only  
(B) B only  
\* (C) Both A and B  
(D) Neither A nor B
4. To fit a 2 1/4" (57 mm) diameter pipe to fit over another 2 1/4" (57 mm) diameter pipe, a technician should expand the pipe to:  
(A) 2 3/8" (60 mm) OD.  
(B) 2 1/8" (54 mm) OD.  
(C) 2 1/2" (64 mm) ID.  
\* (D) 2 1/4" (57 mm) ID.

---

## X1 SAMPLE QUESTIONS (CONTINUED)

5. When performing a "converter-back" exhaust system installation, a technician should:  
(A) replace all hangers.  
\* (B) check for proper clearances.  
(C) weld each connection.  
(D) test for proper backpressure.
6. Technician A says that a broken transmission mount could cause the exhaust system to become misaligned.  
Technician B says that a broken engine mount could cause the exhaust system to become misaligned.  
Who is right?  
(A) A only  
(B) B only  
\* (C) Both A and B  
(D) Neither A nor B
7. Which of these is an illegal procedure to perform on a catalytic converter equipped vehicle?  
\* (A) Install a test pipe in place of the converter.  
(B) Install a muffler before the converter.  
(C) Install a converter bolted directly to the exhaust manifold.  
(D) Install a three-way converter in place of a two-way converter.
8. The flex pipe, located between the exhaust manifold and the catalytic converter, is broken. A flex pipe should be used as a replacement because it:  
(A) strengthens the exhaust systems.  
(B) quiets the exhaust system.  
(C) helps to heat the converter.  
\* (D) allows for engine movement.

---

## TEST PREP & TRAINING

Taking an ASE certification test doesn't have to be a high stress challenge. The ASE website contains test preparation and training information tailored to your specific needs. Visit [www.ase.com](http://www.ase.com) and use the "Test Prep & Training" tab. We've loaded this section of our website with plenty of information to help boost both your knowledge and your confidence—two of your most important tools as a test-taker.

### ***Official ASE Practice Tests***

The easy way to try your hand at taking ASE-style certification exams, without the stress and high stakes of the real thing. [www.ase.com/practice](http://www.ase.com/practice)

### ***Test Taking Tips***

An easy, self-guided introduction to taking your ASE certification test, including examples of the types of questions you'll see and proven tips for success. [www.ase.com/testingtips](http://www.ase.com/testingtips)

### ***Study Guides***

Free, step-by-step guides to help you understand what's involved in each test—including sample questions and suggestions for further preparation. [www.ase.com/studyguides](http://www.ase.com/studyguides)

### ***ASE Testing Demo***

Are you new to ASE testing or has it been a few years? The demonstration at [www.ase.com/asedemo](http://www.ase.com/asedemo) will show you how the test platform works, so you'll feel right at home with the testing format.

### ***In-service Training Providers***

You can choose from a variety of training programs, both instructor-led and self-directed, that have been evaluated through a quality-assurance process and verified as ASE accredited training providers.

### ***Community Colleges and Technical Training Schools***

Get instructor-led, hands-on training at schools accredited by the ASE Education Foundation.

### ***ATMC for more training options***

The ASE Training Managers Council is a professional organization of individuals responsible for the development and delivery of training in the auto and truck industries. The ATMC administers the ASE Accredited Training Provider of Continuing Automotive Service Education program. A list of ASE accredited training providers can be found at [www.atmc.org](http://www.atmc.org).

### ***Other test prep and training programs***

Many test-takers have used aftermarket test prep and training programs and found them helpful. Please note that ASE has neither reviewed nor approved the content of these programs and providers.



COPYRIGHT © 2021 by  
National Institute for  
AUTOMOTIVE SERVICE EXCELLENCE  
All rights reserved



National Institute for  
**AUTOMOTIVE SERVICE EXCELLENCE**  
1503 Edwards Ferry Road, NE  
Suite 401  
Leesburg, VA 20176

*To contact us:*

**703-669-6600**

***www.ase.com***