



Enriching Lives

TAMPER PROOF KINETIC AIR VALVE

AS PER IS : 14845



KIRLOSKAR BROTHERS LIMITED

A Kirloskar Group Company

TAMPER PROOF KINETIC AIR VALVE

Widely accepted by Municipal Corporations, Irrigation Authorities, Water Supply Authorities, National Thermal Power Corporation, Nuclear Power Corporation and Industrial users.

Designed as per latest editions of IS specifications.

Applications :

- Kinetic Air Valves are commonly used in air venting / air admission services in water pipelines. Designed to operate with the floats inside, Kirloskar Tamper Proof Kinetic Air Valve offers reliable service over a longer period of time
- Turbid or clear water
- Sewage

Operating Principles :

- To Release air when the main is being filled and to close and remain closed when the pipe is full to prevent loss of water
- Open and admit air while the main is being emptied
- Release air accumulated under pressure during normal working conditions in the pipe, again without loss of water. In Kinetic Air Valve, this operation is effected automatically by means of a float working in conjunction with an orifice of appropriate type for the duty

Why Tamper Proof Kinetic Air Valve ?

- Performance of Kinetic Air Valve gets severely affected by tampering the valve with an external mechanism
- Conventional Kinetic Air Valves have been found misused by people on many occasions by tampering the valves to collect water for daily use. This leads to any continuous leakage through valve and a wastage of water. Also there is no control on valve performance after tampering
- Kinetic Air Valves are commonly found tampered:
 - By pressing the float from Large Orifice, water comes out due to high internal pressure
 - By loosening/ removing the cowl and inserting rod or other similar objects
 - By removing high pressure Air Release orifice
- KBL has conducted a detailed study of the Kinetic Air Valves installed at various locations to identify the causes of performance failure. KBL took inputs from that study and site observations for designing a new Tamper Proof Kinetic Air Valve with added features

Design Features :

- Tamper Proof design of Cowl
- Tamper Proof design for Bolting
- Tamper Proof design of High Pressure Orifice Cover and Orifice
- Has aesthetically elegant design
- Is ideally suited for turbid / clear water and for sewage application
- Eliminates wastage of water and ensures proper use of natural resource
- Reliable performance of valve
- Longer service life
- Easy maintenance
- Clean Environment

Salient Features :

- Kirloskar Tamper Proof Kinetic Air Valve is a combination of a small and a large orifice air valve
- A separate conventional isolating Sluice Valve is provided for inspection / maintenance of the air Valve without closing the main line
- Non clogging and self sealing float for trouble free operation
- Perfect guide for small orifice float and guide ribs with minimum clearance for large orifice float for smooth movement without wobble during operation
- Suitably shaped and precisely finished small orifice to enhance small orifice float life
- Specially designed cowl to prevent unauthorized access to the large orifice float
- Innovative design of high pressure cover and orifice
- Provision of Tamper Proof hexagonal cap screws

Material of Construction

Scope	Body, Cowl, HP Cover, LP Cover	HP - Orifice Plug	Float for HP - Chamber	Float for LP - Chamber	LP Seat ring
Standard	CI IS 210 Gr FG 260	Bronze IS 318 GR LTB2	SS AISI 304	SS AISI 304	Natural Rubber
Optional	SG Iron IS : 1865, 2% Ni Cast Iron, ASTM A 439 Type D2, Cast Steel IS : 1030/ ASTM A 216 Gr WCB SS CF8 / CF8M / Duplex	SS AISI 304 SS AISI 316	SS AISI 316	SS AISI 316	EPDM BUNA-N Neoprene

Note :1. For special material of construction ,Contact Design Office.

2. Protective coating for Body / Cowl / Cover as per requirement.

3. HP - High Pressure, LP - Low Pressure.

End Connection

Scope	Flange Drilling Standard
Standard Supply	IS : 1538 Table 4 and 6
Optional	BSEN 1092-2 PN 10, PN 16
	BS:10-Table D / E / F
	IS : 1538 Table 5
	ANSI B 16.1 / 16.5
	DIN 2532 (ND 10)
	IS: 6392

General Outline Drawing and Cut View :

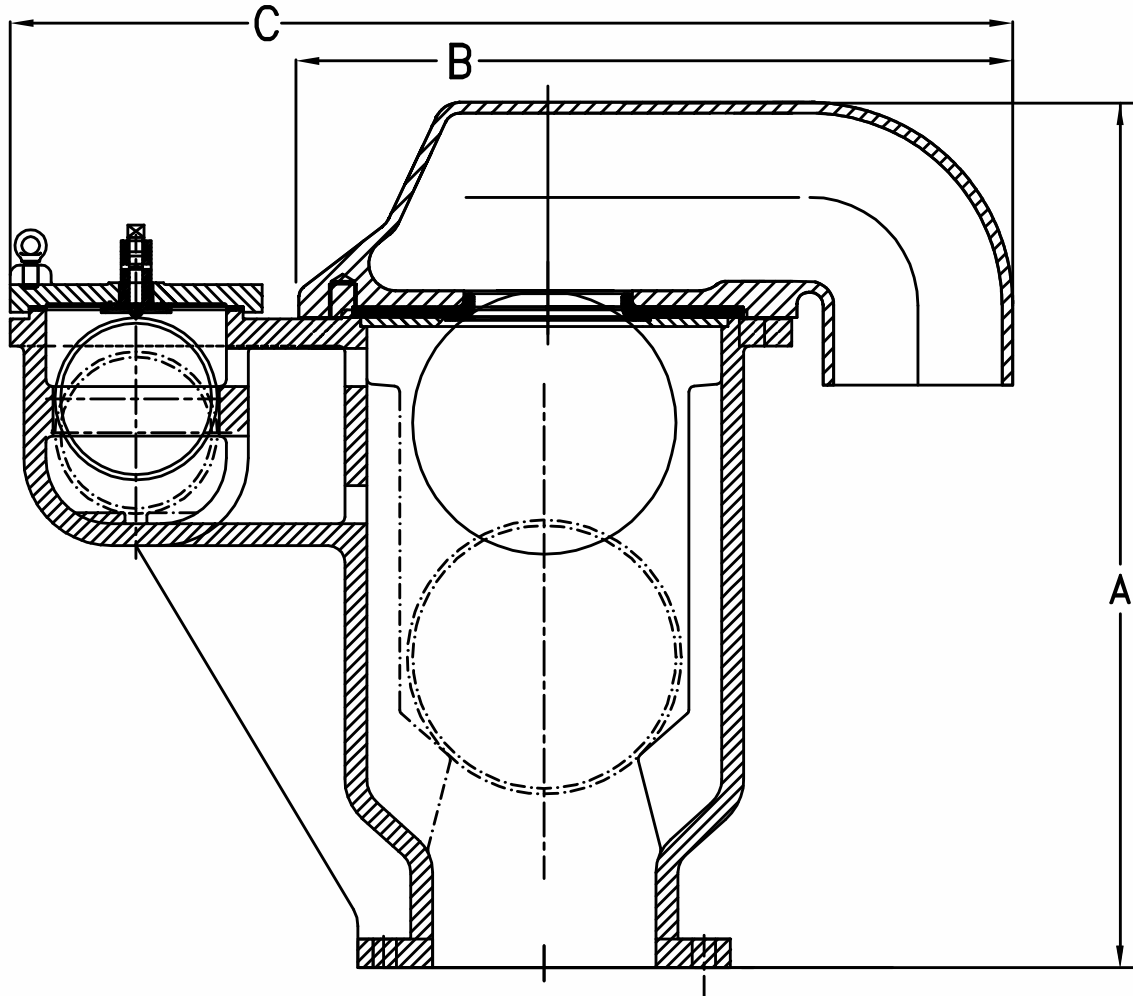

General Outline Dimensions :

Valve Size	A Min	B Min	C Min	Suitable for Main Size
50	280	211	352	125 to 200
80	305	236	373	225 to 350
100	360	280	424	400 to 500
150	487	450	674	600 to 900
200	700	506	739	1000 to 1200
250	700	570	820	1000 to 1200

Note : 1. All dimensions are in 'mm' otherwise stated.

2. For pipeline sizes above 1200 mm, Air Valve sizes may be decided by the customer based on Surge Analysis study.

3. Larger size Air Valve requirement can be met by equivalent Cluster Arrangement using smaller sizes.

Technical Specifications :

Design and Manufacturing Standard	Testing Standard	Size Range	Pressure Rating
IS:14845	IS:14845	50 mm to 250 mm	IS:14845 PN 1.0, PN 1.6

Note :1. For Higher Pressure Rating Contact Design Office

Hydrostatic Test Pressures : IS : 14845

Scope	Size Range	Manufacturing Standard and Pressure Rating (MPa)	Hydrostatic test Pressures Kg/Cm2 (MPa)	
			Body	Seat
Standard Supply	50 -250 mm	IS : 14845 PN 1.0	15.29 (1.5)	10.19 (1.0)
	50 -250 mm	IS : 14845 PN 1.6	24.47 (2.4)	16.31 (1.6)
Optional	For Higher Pressure ratings can be supplied on case to case basis			

OUR GLOBAL PRESENCE



ABOUT KBL

Kirloskar Brothers Limited (KBL) is a world class pump manufacturing company with expertise in engineering and manufacture of systems for fluid management. Established in 1888 and incorporated in 1920, KBL is the flagship company of the \$ 2.1 billion Kirloskar Group. KBL, a market leader, provides complete fluid management solutions for large infrastructure projects in the areas of water supply, power plants, irrigation, oil & gas and marine & defence. We engineer and manufacture industrial, agriculture and domestic pumps, valves and hydro turbines.

In 2003, KBL acquired SPP Pumps, United Kingdom and established SPP INC, Atlanta, USA, as a wholly owned subsidiary of SPP, UK to expand its international presence. In 2007, Kirloskar Brothers International B.V., The Netherlands and Kirloskar Brothers (Thailand) Ltd., a wholly owned subsidiary in Thailand, were incorporated. In 2008, KBL incorporated Kirloskar Brothers Europe B.V. (Kirloskar Pompen B.V. since June 2014), a joint venture between Kirloskar International B.V. and Industrial Pump Group, The Netherlands. In 2010, KBL further consolidated its global position by acquiring Braybar Pumps, South Africa. SPP MENA was established in Egypt in 2012. In 2014, KBL acquired SyncroFlo Inc., the largest independent fabricator of commercial and municipal domestic water booster pumps.

To further strengthen its global position, in 2015, Kirloskar Pompen B.V. acquired Rodelta Pumps International, The Netherlands.

KBL has joint venture cooperation with Ebara, Japan since 1988 for the manufacture of API 610 standard pumps. Kirloskar Corrocoat Private Limited is a joint venture cooperation with Corrocoat, UK since 2006. KBL acquired The Kolhapur Steel Limited in 2007 and Hematic Motors in 2010.

KBL has eight manufacturing facilities in India at Kirloskarvadi, Dewas, Kondhapuri, Shirwal, Sanand, Kaniyur, Kolhapur and Karad. In addition, KBL has global manufacturing and packaging facilities in Egypt, South Africa, Thailand, The Netherlands, United Arab Emirates, United Kingdom and United States of America. KBL has 12,700 channel partners in India and 80 overseas and is supported by best-in-class network of Authorised Centres and Authorised Refurbishment Centres across the country.

All the manufacturing facilities at KBL are certified for ISO 9001, ISO 14001, ISO 50001, BS OHSAS 18001 and SA8000. In addition, the Kirloskarvadi plant is also certified for N & NPT Stamp. KBL's corporate office in Pune is certified for ISO 9001 & Sa8000.

The factories deploy Total Quality Management tools using European Foundation for Quality Management (EFQM) model. The Kirloskarvadi plant of KBL is a state-of-the-art integrated manufacturing facility having Asia's largest hydraulic research centre with testing facility upto 5000 kW and 50,000 m³/hr.

KBL is the ninth pump manufacturing company in the world to be accredited with the N and NPT certification by American Society of Mechanical Engineers (ASME).

Pumps | Valves | Hydro Turbines | Turnkey Projects

Water Resource Management | Irrigation | Power | Industry | Oil & Gas | Marine & Defence | Building & Construction | Distribution (Small Pumps) | Valves | Customer Service & Spares

KIRLOSKAR BROTHERS LIMITED

A Kirloskar Group Company

Registered Office: Udyog Bhavan, Tilak Road , Pune 411002. Tel: +91(20)24440770, Global Headquarters: "Yamuna", Survey No. 98/(3.7), Baner, Pune 411045. Tel: +91(20)27214444, Email: marketing@kbl.co.in, Website: www.kirloskarpumps.com, CIN No.: L29113PN1920PLC000670

OUR COMPANIES



United Kingdom



U.S.A.



South Africa



India



The Netherlands

Kirloskar Brothers Limited reserve the right to make alteration from time to time and such our products / equipments may differ from that detail in this publication. For latest information you may get in touch with our Regional Sales Offices.