

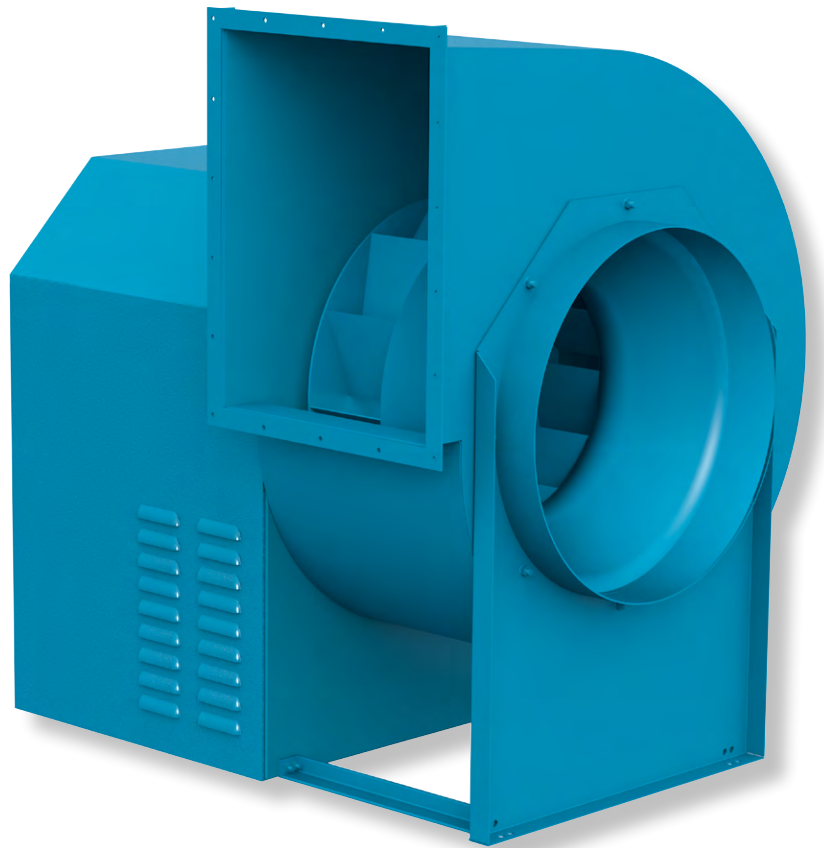

INDUSTRIAL PROCESS AND  
COMMERCIAL VENTILATION SYSTEMS

## UTILITY SETS

DCV | BCV | BCVR | BCVSH  
BAV | DDF | FCV



Model DCV



Now Available with



see page 10



Most DCV fans are available for listing under UL 705, UL 762 or UL Emergency Smoke Control Systems.

Twin City Fan & Blower certifies that the Model DCV fans shown herein are licensed to bear the AMCA Seal. The ratings shown are based on tests and procedures performed in accordance with AMCA Publication 211 and AMCA Publication 311 and comply with the requirements of the AMCA Certified Ratings Program. See Fan Selector Program for sound ratings.

The AMCA Certified Ratings Seal applies to air and sound performance for Model DCV sizes 90, 105, 122, 135, 150, 165, 182, and 200. The AMCA Certified Ratings Seal applies to Fan Efficiency Grade for Model DCV Sizes 150, 165, 182 & 200.

Twin City Fan & Blower certifies that the Model FCV fans shown herein on pages 23-25 are licensed to bear the AMCA Seal. The ratings shown are based on tests and procedures performed in accordance with AMCA Publication 211 and comply with the requirements of the AMCA Certified Ratings Program. See Fan Selector Program for sound ratings.

Twin City Fan & Blower certifies that the Model BCV, BCVR, BCVSH and BAV fans shown herein are licensed to bear the AMCA Seal. The ratings shown are based on tests and procedures performed in accordance with AMCA Publication 211 and AMCA Publication 311 and comply with the requirements of the AMCA Certified Ratings Program. See Fan Selector Program for sound ratings.

## OVERVIEW

### Utility Sets

Twin City Fan's line of utility ventilating sets is one of the most comprehensive in the industry. Utility sets are an excellent choice for general exhaust and supply requirements of commercial and light industrial applications. They are suitable for indoor usage and outdoor usage, with the addition of a weather cover to enclose the motor and drives. Class I and Class II fan housings are continuously welded steel construction and are rotatable to the seven standard discharge positions. Class L fans are lock seam galvanized steel construction and are rotatable to five standard discharge positions.

#### Typical Applications Include

Data Center Exhaust, General HVAC, Elevator Shaft Exhaust/Pressurization, Restroom Exhaust, Stairwell Pressurization, Industrial Ovens, Vehicle Exhaust Generator Room Ventilation, Swimming Pool Exhaust, Kitchen Exhaust, Dishwasher Exhaust, Elevator Shaft Exhaust/Pressurization, Emergency Smoke Exhaust, Stairwell Pressurization

#### Arrangements

Available in Arrangement 4 (Direct Drive) & Arrangement 10 (Belt Driven) configurations

#### Wheel Types

Flat-Bladed Backward Inclined, Airfoil, Forward Curved

#### Standard Construction

Class L, I & II

#### Optional Construction

High Temperature, Special Materials, Spark Resistant, UL 705, UL 762, UL Smoke & Heat, Seismic

#### Certifications

AMCA Sound/Air and FEG, UL 705 Listed for Electrical, UL 762 Listed for Grease-Laden Air, UL Listed for Smoke Control Systems, OSHPD Seismic - OSP-0195-10



For complete product performance, drawings and available accessories, download our Fan Selector program at [tcf.com](http://tcf.com).

## OVERVIEW

### Models

#### General HVAC Fans

##### **DCV (Direct Drive)**

Backward inclined wheel  
10.5" to 20" wheel diameters  
Airflow to 8,200 CFM  
Static pressure to 2.5" w.g.



##### **BCV (Belt Driven)**

Backward inclined wheel  
10.5" to 60" wheel diameters  
Airflow to 78,660 CFM  
Static pressure to 8" w.g.



##### **BAV (Belt Driven)**

Backward inclined airfoil wheel  
12.25" to 36.5" wheel diameters  
Airflow to 32,100 CFM  
Static pressure to 8" w.g.



##### **DDF (Direct Drive)**

Forward curved wheel  
6" to 10.5" wheel diameters  
Airflow to 2,100 CFM  
Static pressure to 1.75" w.g.

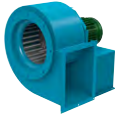

##### **FCV (Belt Driven)**

Forward curved wheel  
7.5" to 36.5" wheel diameters  
Airflow to 29,100 CFM  
Static pressure to 5" w.g.



#### Kitchen & Restaurant Fans

##### **BCVSR (Belt Driven)**

Backward inclined wheel  
10.5" to 36.5" wheel diameters  
Airflow to 29,100 CFM  
Static pressure to 8" w.g.  
Temperatures up to 300°F

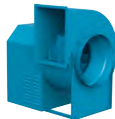

#### Smoke & Heat Applications

##### **BCVSH (Belt Driven)**

Backward inclined wheel  
12.25" to 60" wheel diameters  
Airflow to 78,660 CFM  
Static pressure to 8" w.g.



#### Temperature Rating

500°F for 4 Hours  
1000°F for 15 Minutes



General HVAC  
Supply and Exhaust



Smoke & Heat (Emergency Smoke Control)  
and Restaurant Exhaust



Model DCV

## DCV (Direct Drive)

Direct Drive model featuring a flat bladed backward inclined wheel. Utilized in applications requiring high CFM at low and medium pressures. Model DCV can handle clean air streams.

10.5" to 20" wheel diameters  
Airflow to 8,200 CFM  
Static pressure to 2.5" w.g.

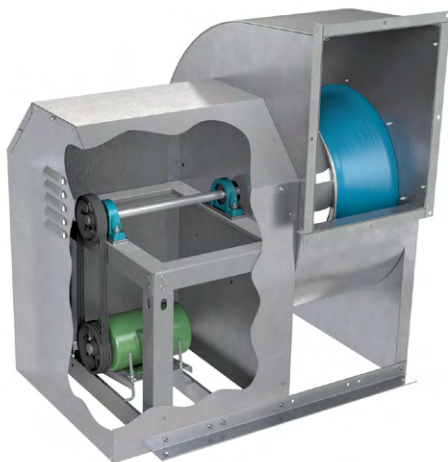

Model BCV  
Class L

## BCV (Belt Driven)

Belt driven model featuring a flat bladed backward inclined wheel. Utilized in applications requiring high CFM at low to medium pressures. Model BCV can handle clean air or corrosive airstreams.

10.5" to 60" wheel diameters  
Airflow to 78,660 CFM  
Static pressure to 8" w.g.

## BCVR (Belt Driven - Kitchen Exhaust)

BCVR packages include V-belt drives, motor, UL weather cover, bolted access door, drain connection, backplate fins, UL 762 labels and nameplate. For UL 762, grease pans, disconnect switches, stacks or fan platforms are not included. Fans must be installed per local codes and NFPA 96.

10.5" to 36.5" wheel diameters  
Airflow to 29,100 CFM  
Static pressure to 8" w.g.  
Temperatures up to 300°F

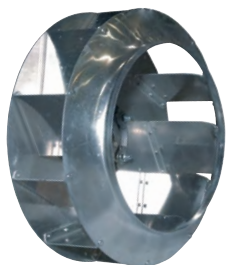

Wheels for DCV & BCV Class L & Class I sizes 122 through 270 are constructed of riveted aluminum. For operating temperatures over 250°F, a welded steel wheel is provided.



Wheels for BCV Class L & Class I sizes 300 through 365, as well as all BCV Class II sizes, are constructed of welded steel.

## BCVSH (Belt Driven - Smoke & Heat)

BCVSH fans come standard with V-belt drives with a minimum of two belts, motor, UL weather cover, backplate fins, shaft seal, shaft cooler, high temperature grease, insulated drive stand and UL Emergency Smoke Control Systems labels and nameplate. Fans must be installed per local codes and NFPA 96.

12.25" to 60" wheel diameters  
Airflow to 78,660 CFM  
Static pressure to 8" w.g.

### Temperature Rating

500°F for 4 Hours  
1000°F for 15 Minutes

## BAV (Belt Driven)

Belt driven model featuring a backward inclined airfoil wheel. Slightly higher efficiencies than the BCV, but recommended for clear air applications only. Airflow capacity from 690 to 32,100 CFM and static pressures to 8" w.g.

Wheels for BAV sizes 245 and smaller are constructed of aluminum using extruded aluminum blades. For sizes 270 and larger, a welded steel wheel is provided.

12.25" to 36.5" wheel diameters  
Airflow to 32,100 CFM  
Static pressure to 8" w.g.

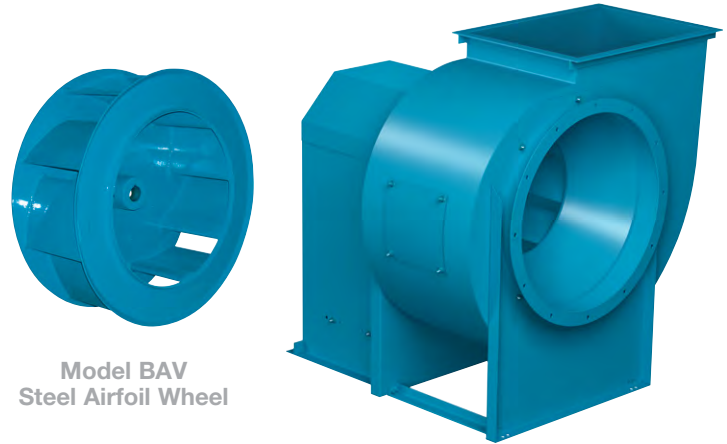

Model BAV  
Steel Airfoil Wheel

## DDF (Direct Drive)

DDF fans are ideal for applications where general ventilation or exhaust is required in small areas such as washrooms, restaurant counters, exhaust hoods and similar environments. All DDF fans are equipped with riveted steel wheels.

6" to 10.5" wheel diameters  
Airflow to 2,100 CFM  
Static pressure to 1.75" w.g.

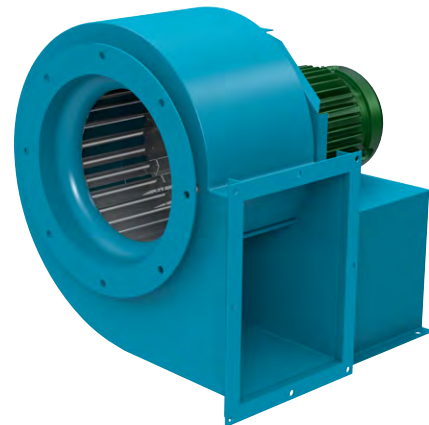

Model DDF

## FCV (Belt Driven)

Belt driven model featuring a forward curved wheel. Ideal for high volume, low pressure applications. Also suitable for certain high temperature requirements. All FCV fans are equipped with riveted steel wheels.

7.5" to 36.5" wheel diameters  
Airflow to 29,100 CFM  
Static pressure to 5" w.g.

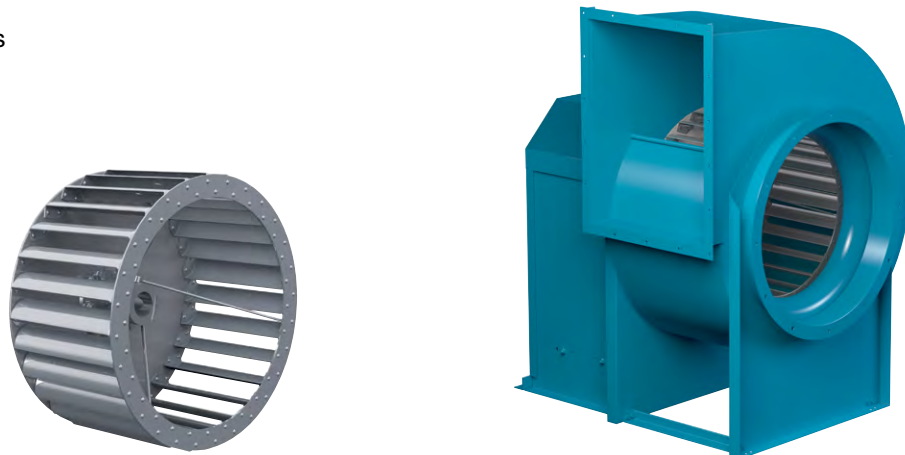

Model FCV

Models DDF & FCV  
Forward Curved  
Riveted Steel Wheel



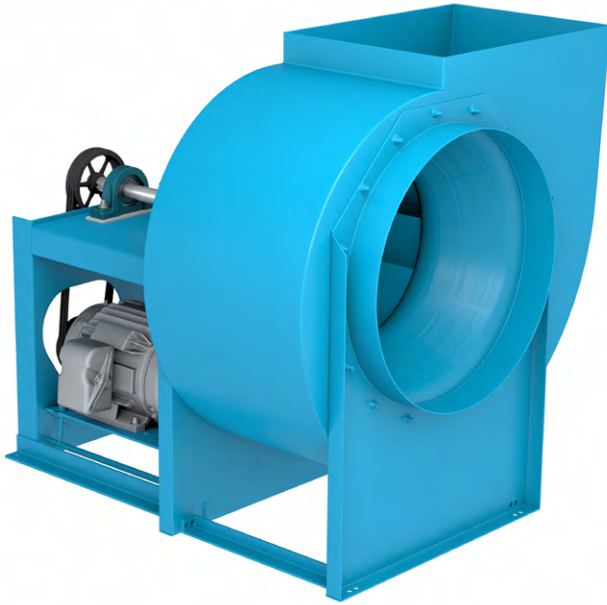

Model BCV  
Class I



Model BCV  
Class II

## Class L, I and II Construction

### Inlet Cone

Deep spun cone, aerodynamically designed for smooth air entry into the wheel.

### Motor/Bearing Pedestal

Large open motor compartment allows complete access to motor and motor base for quick and easy servicing and belt tension adjustment.

### Motor

Available in various sizes, voltages, enclosures and efficiencies to meet the needs of any application.

### Drive

Adjustable or fixed pitch, 1.2 or 1.5 service factor V-belt drives with cast iron sheaves, and V-belts designed to be oil and heat resistant, and to dissipate static electricity.

### Bearings

Heavy duty grease lubricated pillow block bearings selected for minimum average life (AFBMA L-50) of at least 200,000 hours at maximum class speed.

### Shaft

AISI 1045, turned, ground and polished for accuracy. Designed to provide first critical speed of at least 1.43 times the maximum class speed.

### Outlet Flange

Standard on all DCV, Class L sizes and Class II sizes 222 and larger.



## CLOCKWISE (CW) - ROTATION & DISCHARGE (ROTATION VIEW FROM DRIVE SIDE)

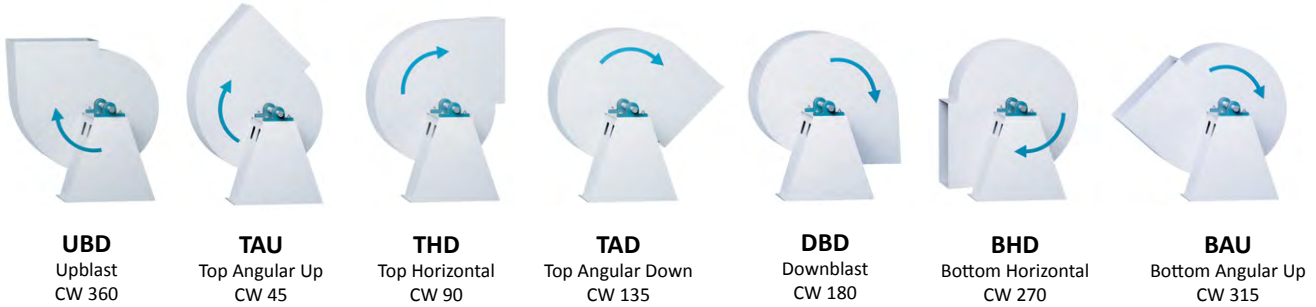

## COUNTER CLOCKWISE (CCW) - ROTATION & DISCHARGE (ROTATION VIEW FROM DRIVE SIDE)

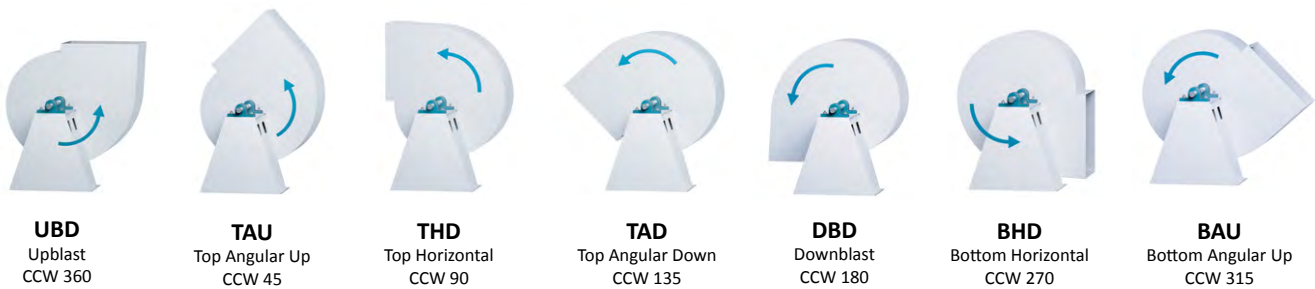

AVAILABLE DISCHARGES	
<b>BCV Class L</b>	BAU, BHD, TAU, THD, UBD
<b>DCV</b>	BAU, BHD, TAU, THD, UBD
<b>BCV, Size 90-105</b>	BAU, BHD, TAU, THD, UBD
<b>BCV</b>	BAU, BHD, DBD, TAD, TAU, THD, UBD
<b>BCVR</b>	BHD, DBD, THD, UBD
<b>BCVSH</b>	BHD, DBD, THD, UBD
<b>BAV</b>	BAU, BHD, DBD, TAD, TAU, THD, UBD
<b>DDF</b>	BAU, BHD, TAU, THD, UBD
<b>FCV, Size 75-105</b>	BAU, BHD, TAU, THD, UBD
<b>FCV</b>	BAU, BHD, DBD, TAD, TAU, THD, UBD



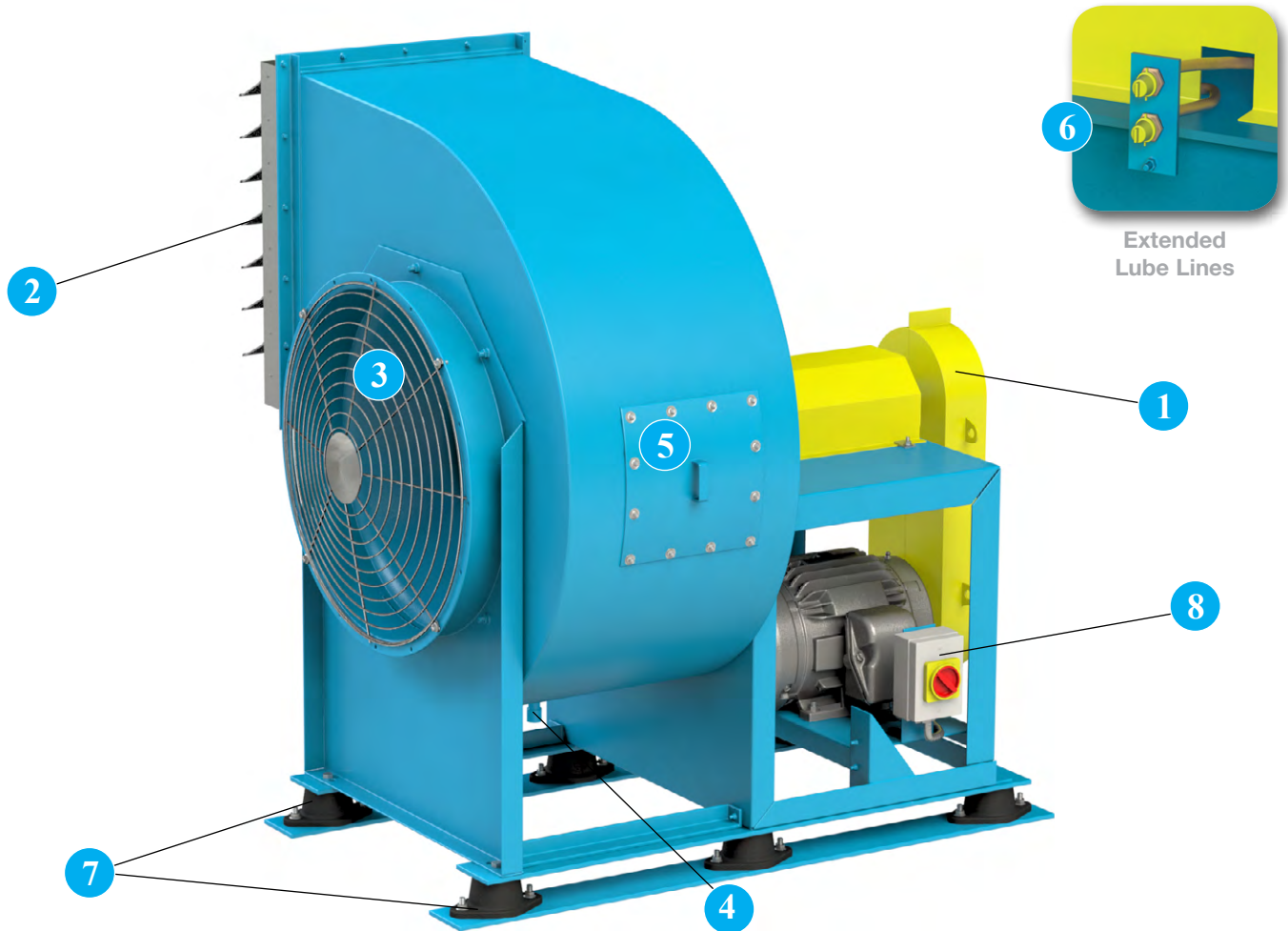

Extended Lube Lines

- 1 Belt Guard** Standard belt guards are of the open back style, and are readily removable for belt or pulley adjustments. For OSHA-style belt guards, see notes on weather cover.
- 2 Gravity Dampers** Flange mounted damper is available for exhaust or supply applications. If outlet velocity of the fan is less than 600 fpm, a spring kit must be specified.
- 3 Inlet and Outlet Screens** Safety screens are available for mounting in the fan inlet or outlet in non-ducted applications.
- 4 Standard Drain** All fans are constructed with a weep hole in the bottom of the housing. A threaded pipe coupling is welded to the lowest point in the housing scroll to permit wash water or condensation to drain from the fan. All fans are constructed with a weep hole in the bottom of the housing.
- 5 Bolted Access Door** Bolted access door allows for inspection and maintenance of internal fan components.
- 6 Extended Lube Lines** Allow for easy lubrication of bearings on belt driven units without disassembly by extending polyethylene lines from fan bearings to exterior of the guard.
- 7 Vibration Isolation - Spring** Spring type vibration isolation mounts are available to reduce the transmission of fan vibration in 1" or 2" deflection.
- 8 Disconnect Switch (NEMA 4)** A NEMA 4, water and dust tight, disconnect is available shipped loose for field mounting and wiring or factory mounted and wired externally.



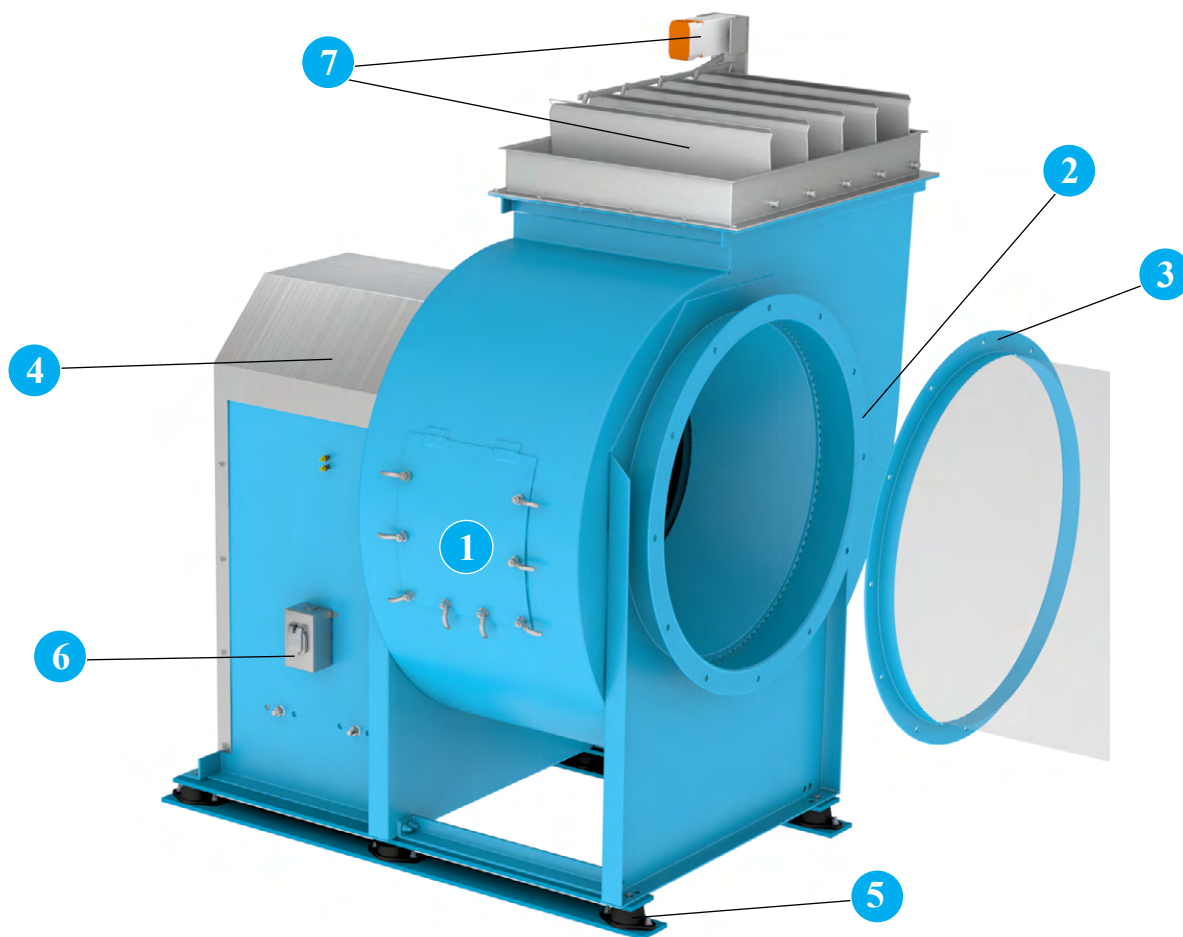

**1 Quick Open Access Doors** For quick wheel inspection and maintenance. Access doors are specified where examination and cleaning of the fan interior is required.

**2 Inlet Flange** Inlet and outlet flanges with prepunched mounting holes are available on all sizes to provide a bolted connection to ductwork.

**3 Inlet Companion Flange** Companion flanges are commonly connected to a user's duct for easy installation of flexible connections between the fan and duct. Companion flanges and flex connectors are punched to match the fan's inlet or outlet punching.

**4 Weather Cover** An easily removable weather cover is available for either Class L, I or Class II fans. The weather cover provides complete protection for the motor, fan bearings, and V-belt drive. If an OSHA-style belt guard is specified on vent sets, a weather cover will be supplied.

**5 Vibration Isolation - RIS Rails** Vibration Rails with RIS Isolators are designed to limit forces transmitted to the support structure of an operating fan. Constructed of structural angle, the rails extend the distance between mounting points distributing a more even load to the isolators. Rubber-in-shear type isolators and flexible connectors at inlet and outlet are required.

**6 Disconnect Switch (NEMA 3R)** A NEMA 3R, rain proof, disconnect is available shipped loose for field mounting and wiring or factory mounted and wired externally.

**7 Motorized Shutter** Motorized shutters are recommended for low CFM applications to assure unrestricted airflow.

#### OTHER ACCESSORIES:

- Shaft Seal
- Shaft Cooler
- 4" Raised Access Door



Model DCV  
With GridSmart™ EC Motor

Twin City Fan offers its own line of custom engineered Electronically Commutated (EC) motors. Electronic commutation is the latest motor technology to be used in direct drive fans. Also known in the industry as Brush Free or Brushless DC, the EC motors utilize an electronic circuit board to control the functionality of the motor. The motor operates off of single phase AC power, which is converted to DC power within the motor's circuitry. TCF has motor options available for 115V or 208-230V single phase electrical power. The result is a highly efficient motor, even at part load, with an expanded speed control range and a variety of speed control options from which to choose. EC motors are available in ODP, TENV and TEFC enclosures.



## Benefits

- Efficiencies up to 85%
- Constant efficiency as the motor speed is varied
- Up to 66% energy savings over traditional PSC motors
- Performance range comparable to a belt drive fan with reduced maintenance benefits of a direct drive fan
- 80% usable turndown range as compared with 40% maximum on PSC motors
- Soft start gives fans smooth, quiet start
- Lower operating temperatures result in longer life and reduces energy consumption
- Heavy duty ball bearings are permanently lubricated
- Elimination of VFD results in lower initial cost



1/4HP to 1HP  
GridSmart™ EC Motors

## EC Motor Options

### 1/4HP to 1HP

- 115V single phase
- ODP Enclosure
- Motor mounted speed control dial as standard
- 0-10VDC control leads as standard
- Available with remote mounted speed control dial

### 1HP & 2HP

- 1HP - 115V, 208-230V, single phase
- 2HP - 208-230V, single phase
- TEFC enclosure (totally enclosed fan cooled)
- Available with motor mounted speed dial or 0-10VDC control lead

### 1HP to 3HP - 3 Phase

- 230-460V, 3 phase
- Open enclosure
- Available with remote mounted speed control dial



1HP & 2HP  
GridSmart™ EC Motors



1HP to 3HP 3 phase  
GridSmart™ EC motors

## High Temperature Construction

Standard fan design options are available to handle airstream temperatures to 600°F. Consult your Twin City Fan & Blower representative for applications over 600°F. High temperature operating limits and necessary modifications are shown in Table 1.

Table 1. High Temperature Construction Requirements

TEMPERATURE (°F)	WHEEL MATERIAL	BEARING LUBRICATION	OTHER REQUIREMENTS
-20 TO 250°F	Riveted Aluminum on 90-270 BCV Class I. All Others Steel.	Grease	Standard Fan
251 TO 300°F	Steel	Grease	Standard Fan
301 TO 500°F	Steel	High Temperature Grease	Shaft Cooler, Shaft Seal, Expansion & Non-Expansion Bearings; Class II: Insulated Heat Gap
501 TO 600°F CLASS II ONLY	Steel	High Temperature Grease	Shaft Cooler, Shaft Seal, Expansion & Non-Expansion Bearings; High Temperature Aluminum Paint, Insulated Heat Gap

1. When selecting the performances at elevated temperatures and altitudes, refer to the method used in Catalog 300.
2. Excludes DCV & Class L.

## Spark Resistant Construction

AMCA TYPE	FAN CONSTRUCTION
A	All Airstream Parts are Aluminum (Wheel, Housing, and Shaft Seal). Limited to 250°F.
B	Aluminum Wheel and Rubbing Plate. Limited to 250°F.
C	To 250°F — 90 To 270 BCV Class I: Aluminum Wheel and Rubbing Plate
	251 To 500°F — 90 To 270 BCV Class I & II: Steel Wheel, Aluminum Inlet Cone and Rubbing Plate
	All Other To 500°F — Aluminum Inlet Cone and Rubbing Plate

### NOTES:

1. Bearings shall be placed outside the airstream.
2. The user shall electrically ground all fan parts.
3. The use of the above standard in no way implies a guarantee of safety for any level of spark resistance. "Spark resistant construction also does not protect against ignition of explosive gases caused by catastrophic failure or from any airstream material that may be present in the system."

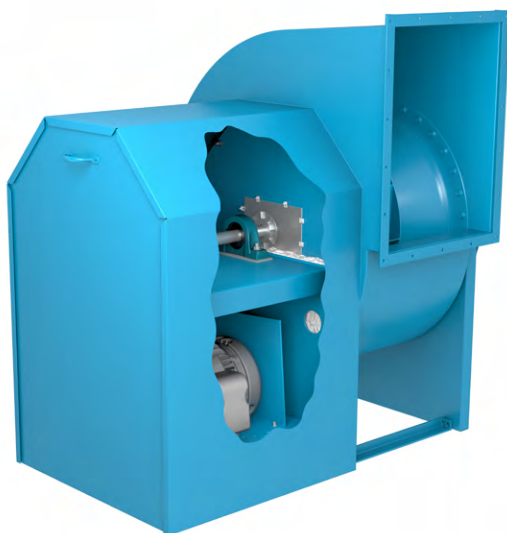

BCV  
High Temperature Construction

### High Temp Options/Accessories Include:

- High Temp Grease
- Heat Shield
- Insulated Drive Stand
- Shaft Seal





## Derating Factors For High Temperature

Fan operation at high temperature adversely affects the strength of fan wheels. As a result, the maximum safe speed (RPM) of the fan from Table 3 must be derated by the temperature factor from Table 2.

**Example:** Maximum safe speed at 400°F for a size 245 BCV Class II steel wheel = 0.95 x 2033 = 1931 RPM (2033 RPM is maximum RPM at 70°F).

Table 2. Derating Factors for High Temperature

TEMPERATURE (°F)	ALUMINUM	STANDARD STEEL	STAINLESS STEEL
70	1.00	1.000	1.00
200	1.00	0.980	0.95
250	1.00	0.970	0.93
300	—	0.960	0.91
400	—	0.950	0.88
500	—	0.900	0.84
600	—	0.860	0.81

Table 3. Maximum RPM at 70°F

FAN SIZE	DCV	BCV			FCV	
		CLASS L	CLASS I	CLASS II	CLASS I	CLASS II
90	2576	2576	3682	—	2200	—
105	2723	2723	3682	—	1637	—
122	2158	2158	3167	4119	1559	1871
135	2039	2039	2874	3738	1415	1698
150	1832	1832	2587	3364	1273	1528
165	1604	1604	2352	3058	1157	1389
182	1508	1508	2118	2729	1046	1256
200	1376	1376	1932	2490	955	1146
222	—	1237	1737	2238	858	1030
245	—	1123	1577	2033	780	935
270	—	950	1397	1803	707	849
300	—	—	1257	1623	637	764
330	—	—	1143	1475	579	694
365	—	—	995	1283	523	628
402	—	—	903	1163	—	—
445	—	—	817	1052	—	—
490	—	—	742	956	—	—
542	—	—	670	863	—	—
600	—	—	606	780	—	—

Table 4. DCV & BCV Bare Fan Weights (lb)

FAN SIZE	DCV	BCV		
		CLASS L	CLASS I	CLASS II
90-105	66	73	—	—
122	72	78	121	133
135	81	87	139	153
150	93	101	162	178
165	106	113	198	218
182	127	136	220	242
200	150	163	287	316
222	—	202	348	383
245	—	237	453	498
270	—	274	507	559
300	—	—	662	728
330	—	—	758	834
365	—	—	940	1034
402	—	—	1275	1403
445	—	—	1525	1678
490	—	—	1910	2101
542	—	—	2280	2508
600	—	—	3300	3630

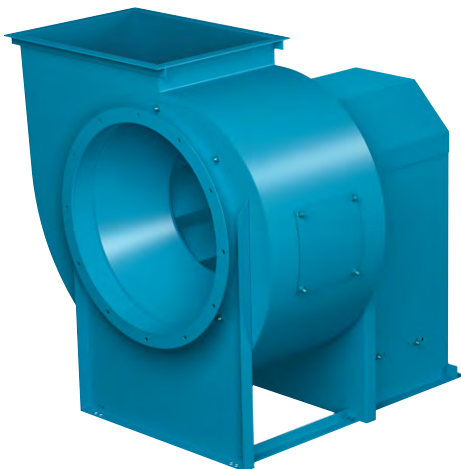

# Backward Inclined

## 90 DCV

Wheel Dia. = 10.50 inches

Outlet Area = 0.653 ft<sup>2</sup>

Max. BHP = 0.019 (RPM÷1000)<sup>3</sup>

RPM	Max BHP	0" SP		0.25" SP		0.5" SP		0.75" SP		1" SP		1.25" SP		1.50" SP		1.75" SP		2" SP		2.25" SP		2.50" SP	
		CFM	BHP	CFM	BHP	CFM	BHP	CFM	BHP	CFM	BHP	CFM	BHP	CFM	BHP	CFM	BHP	CFM	BHP	CFM	BHP	CFM	BHP
1160	0.04	480	0.03	363	0.04	241	0.03																
1750	0.12	724	0.11	650	0.11	566	0.12	494	0.12	408	0.12												

## 105 DCV

Wheel Dia. = 10.50 inches

Outlet Area = 0.653 ft<sup>2</sup>

Max. BHP = 0.026 (RPM÷1000)<sup>3</sup>

RPM	Max BHP	0" SP		0.25" SP		0.5" SP		0.75" SP		1" SP		1.25" SP		1.50" SP		1.75" SP		2" SP		2.25" SP		2.50" SP	
		CFM	BHP	CFM	BHP	CFM	BHP	CFM	BHP	CFM	BHP	CFM	BHP	CFM	BHP	CFM	BHP	CFM	BHP	CFM	BHP	CFM	BHP
1160	0.05	677	0.04	530	0.05	339	0.05																
1750	0.17	1022	0.15	933	0.16	830	0.16	720	0.17	607	0.16	412	0.15										

## 122 DCV

Wheel Dia. = 12.25 inches

Outlet Area = 0.86 ft<sup>2</sup>

Max. BHP = 0.064 (RPM÷1000)<sup>3</sup>

RPM	Max BHP	0" SP		0.25" SP		0.5" SP		0.75" SP		1" SP		1.25" SP		1.50" SP		1.75" SP		2" SP		2.25" SP		2.50" SP	
		CFM	BHP	CFM	BHP	CFM	BHP	CFM	BHP	CFM	BHP	CFM	BHP	CFM	BHP	CFM	BHP	CFM	BHP	CFM	BHP	CFM	BHP
1160	0.12	1264	0.11	1081	0.12	872	0.12	606	0.11														
1750	0.41	1908	0.39	1795	0.40	1669	0.40	1528	0.41	1393	0.41	1250	0.40	1088	0.39	860	0.37						

## 135 DCV

Wheel Dia. = 13.50 inches

Outlet Area = 1.05 ft<sup>2</sup>

Max. BHP = 0.104 (RPM÷1000)<sup>3</sup>

RPM	Max BHP	0" SP		0.25" SP		0.5" SP		0.75" SP		1" SP		1.25" SP		1.50" SP		1.75" SP		2" SP		2.25" SP		2.50" SP	
		CFM	BHP	CFM	BHP	CFM	BHP	CFM	BHP	CFM	BHP	CFM	BHP	CFM	BHP	CFM	BHP	CFM	BHP	CFM	BHP	CFM	BHP
1160	0.19	1692	0.19	1496	0.19	1266	0.19	1022	0.19														
1750	0.66	2553	0.64	2430	0.64	2297	0.65	2146	0.66	1991	0.66	1842	0.66	1684	0.66	1510	0.64	1304	0.62				

## 150 DCV

Wheel Dia. = 15.00 inches

Outlet Area = 1.29 ft<sup>2</sup>

Fan Efficiency Grade: FEG75

Max. BHP = 0.176 (RPM÷1000)<sup>3</sup>

RPM	Max BHP	0" SP		0.25" SP		0.5" SP		0.75" SP		1" SP		1.25" SP		1.50" SP		1.75" SP		2" SP		2.25" SP		2.50" SP	
		CFM	BHP	CFM	BHP	CFM	BHP	CFM	BHP	CFM	BHP	CFM	BHP	CFM	BHP	CFM	BHP	CFM	BHP	CFM	BHP	CFM	BHP
1160	0.33	2321	0.31	2108	0.32	1853	0.33	1600	0.33	1309	0.31												
1750	1.12	3502	1.08	3366	1.09	3222	1.10	3065	1.11	2891	1.12	2722	1.12	2556	1.12	2383	1.12	2201	1.10	1998	1.08	1755	1.05

## 165 DCV

Wheel Dia. = 16.50 inches

Outlet Area = 1.57 ft<sup>2</sup>

Fan Efficiency Grade: FEG75

Max. BHP = 0.284 (RPM÷1000)<sup>3</sup>

RPM	Max BHP	0" SP		0.25" SP		0.5" SP		0.75" SP		1" SP		1.25" SP		1.50" SP		1.75" SP		2" SP		2.25" SP		2.50" SP	
		CFM	BHP	CFM	BHP	CFM	BHP	CFM	BHP	CFM	BHP	CFM	BHP	CFM	BHP	CFM	BHP	CFM	BHP	CFM	BHP	CFM	BHP
1160	0.53	3090	0.51	2858	0.52	2588	0.52	2308	0.53	2020	0.52	1683	0.50										
1604	1.39	4273	1.34	4110	1.35	3937	1.36	3749	1.38	3541	1.39	3337	1.39	3139	1.39	2933	1.39	2715	1.37	2474	1.35	2196	1.31

## 182 DCV

Wheel Dia. = 18.25 inches

Outlet Area = 1.92 ft<sup>2</sup>

Fan Efficiency Grade: FEG80

Max. BHP = 0.466 (RPM÷1000)<sup>3</sup>

RPM	Max BHP	0" SP		0.25" SP		0.5" SP		0.75" SP		1" SP		1.25" SP		1.50" SP		1.75" SP		2" SP		2.25" SP		2.50" SP	
		CFM	BHP	CFM	BHP	CFM	BHP	CFM	BHP	CFM	BHP	CFM	BHP	CFM	BHP	CFM	BHP	CFM	BHP	CFM	BHP	CFM	BHP
1160	0.86	4153	0.76	3942	0.80	3715	0.84	3468	0.86	3181	0.86	2822	0.84	2304	0.76								
1508	1.90	5399	1.66	5239	1.73	5073	1.78	4898	1.83	4715	1.87	4522	1.89	4312	1.90	4076	1.89	3805	1.86	3484	1.80	3068	1.70

## 200 DCV

Wheel Dia. = 20.00 inches

Outlet Area = 2.30 ft<sup>2</sup>

Fan Efficiency Grade: FEG80

Max. BHP = 0.737 (RPM÷1000)<sup>3</sup>

RPM	Max BHP	0" SP		0.25" SP		0.5" SP		0.75" SP		1" SP		1.25" SP		1.50" SP		1.75" SP		2" SP		2.25" SP		2.50" SP	
		CFM	BHP	CFM	BHP	CFM	BHP	CFM	BHP	CFM	BHP	CFM	BHP	CFM	BHP	CFM	BHP	CFM	BHP	CFM	BHP	CFM	BHP
1160	1.37	5466	1.20	5236	1.26	4992	1.31	4731	1.35	4447	1.37	4117	1.36	3717	1.32	3180	1.24						
1376	2.29	6484	2.00	6292	2.07	6092	2.14	5882	2.20	5662	2.24	5431	2.27	5178	2.29	4894	2.27	4570	2.23	4185	2.16	3685	2.04

Performance is for installation Type B & D: Free or ducted inlet, ducted outlet.  
 Power rating (bhp) does not include transmission losses.  
 Performance ratings do not include the effects of appurtenances (accessories).

# Backward Inclined

## 90 BCV/BCVR

Wheel Dia. = 10.50 inches  
Outlet Area = 0.653 ft<sup>2</sup>

Fan Efficiency Grade: FEG67  
Max. BHP = 0.023 (RPM ÷ 1000)<sup>3</sup>

CFM	OV	0.125" SP		0.25" SP		0.5" SP		0.75" SP		1" SP		1.5" SP		2" SP		3" SP		4" SP	
		RPM	BHP	RPM	BHP	RPM	BHP	RPM	BHP	RPM	BHP	RPM	BHP	RPM	BHP	RPM	BHP	RPM	BHP
261	400	829	0.01	970	0.02	1190	0.04												
327	500	964	0.02	1088	0.03	1305	0.05	1470	0.07	1626	0.09								
392	600	1095	0.03	1220	0.04	1409	0.06	1584	0.09	1722	0.12								
457	700	1232	0.04	1352	0.05	1527	0.08	1688	0.11	1836	0.14	2069	0.20						
522	800	1374	0.05	1483	0.07	1659	0.10	1799	0.13	1940	0.17	2184	0.24	2380	0.30				
588	900	1521	0.07	1618	0.09	1794	0.13	1927	0.16	2051	0.20	2295	0.28	2495	0.35	2840	0.50		
653	1000	1668	0.10	1756	0.11	1926	0.16	2059	0.20	2173	0.23	2399	0.32	2608	0.41	2938	0.57	3251	0.75
718	1100	1817	0.12	1898	0.14	2056	0.19	2193	0.23	2304	0.28	2508	0.36	2712	0.46	3052	0.65	3334	0.82
784	1200	1970	0.16	2044	0.18	2190	0.22	2327	0.28	2440	0.32	2631	0.42	2819	0.52	3168	0.73	3444	0.92
849	1300	2121	0.19	2190	0.22	2325	0.27	2457	0.32	2573	0.38	2760	0.48	2932	0.58	3274	0.81	3560	1.03
914	1400	2274	0.24	2338	0.26	2463	0.31	2588	0.37	2705	0.43	2893	0.54	3055	0.65	3377	0.89	3673	1.14
980	1500	2429	0.29	2489	0.32	2606	0.37	2723	0.43	2837	0.49	3029	0.62	3186	0.73	3485	0.98		
1045	1600	2582	0.35	2639	0.38	2749	0.43	2858	0.49	2968	0.56	3162	0.70	3319	0.82	3600	1.07		
1110	1700	2736	0.41	2789	0.44	2894	0.50	2996	0.57	3100	0.64	3294	0.78	3453	0.92				
1175	1800	2890	0.49	2940	0.52	3040	0.58	3137	0.65	3234	0.72	3424	0.87	3587	1.02				
1241	1900	3046	0.57	3094	0.60	3189	0.67	3282	0.74	3373	0.81	3556	0.97						

MAXIMUM RPM: Class L — 2576 Class I — 3682

Selections above 4000 RPM not recommended. Consult factory.

## 105 BCV/BCVR

Wheel Dia. = 10.50 inches  
Outlet Area = 0.653 ft<sup>2</sup>

Fan Efficiency Grade: FEG75  
Max. BHP = 0.031 (RPM ÷ 1000)<sup>3</sup>

CFM	OV	0.25" SP		0.5" SP		0.75" SP		1" SP		1.5" SP		2" SP		3" SP		4" SP		5" SP	
		RPM	BHP	RPM	BHP	RPM	BHP	RPM	BHP	RPM	BHP	RPM	BHP	RPM	BHP	RPM	BHP	RPM	BHP
327	500	901	0.02	1151	0.04	1360	0.07												
392	600	980	0.03	1203	0.05	1403	0.08	1579	0.11										
457	700	1063	0.04	1267	0.06	1453	0.09	1623	0.12	1920	0.19								
522	800	1149	0.05	1346	0.08	1512	0.10	1674	0.14	1961	0.21	2214	0.29						
588	900	1239	0.06	1429	0.09	1585	0.12	1732	0.15	2009	0.24	2255	0.32						
653	1000	1330	0.07	1512	0.11	1665	0.14	1800	0.18	2061	0.26	2300	0.35	2720	0.55				
718	1100	1422	0.09	1598	0.13	1751	0.17	1891	0.22	2157	0.31	2405	0.41	2806	0.63	3158	0.87	3477	1.12
784	1200	1517	0.11	1686	0.14	1831	0.19	1961	0.23	2187	0.32	2405	0.41	2907	0.72	3246	0.98	3555	1.25
849	1300	1614	0.14	1776	0.18	1921	0.24	2051	0.28	2277	0.38	2535	0.49	2907	0.72	3246	0.98	3555	1.25
914	1400	1721	0.15	1868	0.20	2003	0.24	2126	0.30	2343	0.40	2535	0.49	2907	0.72	3246	0.98	3555	1.25
1045	1600	1927	0.21	2058	0.26	2183	0.31	2298	0.37	2509	0.49	2693	0.60	3025	0.83	3348	1.10	3647	1.40
1110	1700	2135	0.29	2253	0.34	2367	0.40	2476	0.45	2676	0.59	2857	0.72	3169	0.97	3462	1.24		
1175	1800	2347	0.38	2455	0.44	2559	0.50	2661	0.57	2850	0.70	3024	0.85	3331	1.14	3600	1.41		
1241	1900	2562	0.49	2660	0.56	2756	0.63	2850	0.70	3030	0.83	3196	0.99	3496	1.32				
1567	2400	2776	0.62	2867	0.70	2956	0.77	3043	0.85	3213	1.00	3371	1.15	3662	1.51				
1698	2600	2994	0.77	3078	0.86	3160	0.94	3241	1.02	3400	1.18	3553	1.34						
1828	2800	3210	0.95	3289	1.04	3366	1.13	3442	1.22	3591	1.39								
1959	3000	3429	1.15	3503	1.25	3575	1.35	3647	1.44										

MAXIMUM RPM: Class L — 2723 Class I — 3682

## 122 BCV/BCVR/BCVSH

Wheel Dia. = 12.25 inches  
Outlet Area = 0.86 ft<sup>2</sup>

Fan Efficiency Grade: FEG80  
Max. BHP = 0.076 (RPM ÷ 1000)<sup>3</sup>

CFM	OV	0.25" SP		0.5" SP		1" SP		1.5" SP		2" SP		3" SP		4" SP		5" SP		6" SP		7" SP		8" SP	
		RPM	BHP	RPM	BHP	RPM	BHP	RPM	BHP	RPM	BHP	RPM	BHP	RPM	BHP	RPM	BHP	RPM	BHP	RPM	BHP	RPM	BHP
688	800	869	0.05	1044	0.08	1335	0.17																
860	1000	994	0.07	1152	0.12	1413	0.21	1642	0.31														
1032	1200	1123	0.11	1271	0.16	1512	0.26	1720	0.37	1911	0.49												
1204	1400	1256	0.15	1397	0.21	1622	0.32	1816	0.45	1992	0.58	2317	0.87										
1376	1600	1396	0.20	1525	0.27	1738	0.40	1922	0.54	2088	0.68	2390	0.98	2671	1.33								
1548	1800	1539	0.27	1655	0.34	1861	0.49	2035	0.64	2193	0.79	2480	1.12	2741	1.48	2989	1.87						
1720	2000	1685	0.36	1790	0.43	1988	0.60	2154	0.76	2305	0.93	2578	1.27	2827	1.65	3059	2.05	3283	2.48	3500	2.94		
1892	2200	1834	0.46	1929	0.54	2116	0.72	2277	0.90	2421	1.08	2683	1.45	2922	1.84	3144	2.26	3355	2.71	3559	3.18	3758	3.67
2236	2600	2135	0.72	2216	0.81	2377	1.01	2531	1.23	2667	1.44	2909	1.87	3131	2.31	3337	2.77	3533	3.25	3719	3.75	3898	4.27
2580	3000	2439	1.07	2511	1.17	2650	1.40	2789	1.64	2921	1.89	3151	2.38	3358	2.88	3552	3.39	3735	3.90	3910	4.44	4079	5.00
2924	3400	2746	1.52	2810	1.64	2934	1.89	3057	2.15	3179	2.43	3402	2.99	3599	3.55	3781	4.11	3955	4.69				
3268	3800	3055	2.09	3112	2.22	3224	2.49	3334	2.78	3444	3.08	3658	3.71	3849	4.34	4023	4.96						

MAXIMUM RPM: Class L — 3167 Class I — 4119

Selections above 4000 RPM not recommended. Consult factory.

Performance is for installation Type B & D: Free or ducted inlet, ducted outlet.  
Power rating (bhp) does not include transmission losses.  
Performance ratings do not include the effects of appurtenances (accessories).

Class L fans are shown in shaded area.  
Class I fans are shown in regular face type.  
Class II fans are shown in bold face type.  
Underlined figures indicate maximum static efficiencies.

















### 75 FCV

Wheel Dia. = 7.6875" inches

Outlet Area = 0.325 ft<sup>2</sup>

Max. BHP = 0.98 (RPM÷1000)<sup>3</sup>

CFM	OV	1/8" SP		1/4" SP		3/8" SP		1/2" SP		5/8" SP		3/4" SP		1" SP		1 1/4" SP		1 1/2" SP	
		RPM	BHP	RPM	BHP	RPM	BHP	RPM	BHP	RPM	BHP	RPM	BHP	RPM	BHP	RPM	BHP	RPM	BHP
260	800	632	0.02	832	0.03	-996	0.05												
292	900	659	0.02	847	0.04	1008	0.05	1148	0.07	1273	0.09								
325	1000	691	0.03	866	0.04	1022	0.06	1159	0.08	1283	0.10	1396	0.12						
357	1100	728	0.03	887	0.05	1037	0.06	1172	0.08	1293	0.11	1405	0.13						
390	1200	769	0.04	912	0.05	1056	0.07	1187	0.09	1306	0.12	1416	0.14	1616	0.19				
422	1300	812	0.05	940	0.06	1075	0.08	1203	0.10	1320	0.13	1428	0.15	1626	0.20	1803	0.25		
455	1400	858	0.05	972	0.07	1099	0.09	1222	0.11	1336	0.14	1443	0.16	1637	0.22	1812	0.27	1973	0.33
487	1500	905	0.07	1008	0.08	1125	0.10	1242	0.13	1354	0.15	1458	0.18	1649	0.23	1823	0.29	1982	0.35
520	1600	954	0.08	1048	0.09	1154	0.11	1265	0.14	1373	0.16	1475	0.19	1663	0.25	1834	0.31	1992	0.37
552	1700	1003	0.09	1088	0.11	1185	0.13	1290	0.15	1393	0.18	1493	0.21	1678	0.26	1847	0.33	2003	0.39
585	1800	1054	0.11	1132	0.12	1222	0.14	1318	0.17	1417	0.19	1513	0.22	1695	0.28	1861	0.35	2015	0.42
617	1900	1104	0.12	1176	0.14	1259	0.16	1348	0.18	1443	0.21	1535	0.24	1713	0.30	1876	0.37	2029	0.44
650	2000	1156	0.14	1223	0.16	1299	0.18	1382	0.20	1470	0.23	1559	0.26	1732	0.33	1893	0.39		
682	2100	1206	0.16	1269	0.18	1340	0.20	1418	0.23	1499	0.25	1585	0.28	1751	0.35				
715	2200	1259	0.19	1319	0.20	1384	0.22	1457	0.25	1533	0.28	1613	0.31	1774	0.37				
747	2300	1310	0.21	1367	0.23	1428	0.25	1496	0.27	1568	0.30	1642	0.33	1798	0.40				
780	2400	1364	0.24	1417	0.26	1474	0.28	1538	0.30	1606	0.33	1675	0.36						
812	2500	1415	0.27	1466	0.29	1521	0.31	1580	0.33	1644	0.36								

### 90 FCV

Wheel Dia. = 9.1875" inches

Outlet Area = 0.451 ft<sup>2</sup>

Max. BHP = 0.291 (RPM÷1000)<sup>3</sup>

CFM	OV	1/8" SP		1/4" SP		3/8" SP		1/2" SP		5/8" SP		3/4" SP		1" SP		1 1/4" SP		1 1/2" SP	
		RPM	BHP	RPM	BHP	RPM	BHP	RPM	BHP	RPM	BHP	RPM	BHP	RPM	BHP	RPM	BHP	RPM	BHP
361	800	495	0.02	665	0.04	804	0.06	924	0.08	1032	0.10	1132	0.12						
406	900	511	0.03	673	0.04	809	0.06	927	0.08	1033	0.11	1130	0.13	1308	0.18				
451	1000	531	0.03	683	0.05	816	0.07	932	0.09	1036	0.12	1132	0.14	1305	0.20				
496	1100	554	0.04	695	0.06	824	0.08	938	0.10	1041	0.13	1135	0.15	1306	0.21	1460	0.27	1603	0.34
541	1200	579	0.04	710	0.06	834	0.09	946	0.12	1047	0.14	1140	0.17	1308	0.23	1459	0.29	1599	0.35
586	1300	607	0.05	728	0.07	845	0.10	954	0.13	1054	0.15	1146	0.18	1312	0.24	1461	0.31	1599	0.38
631	1400	636	0.06	748	0.08	859	0.11	964	0.14	1062	0.17	1153	0.20	1317	0.26	1465	0.33	1600	0.40
676	1500	666	0.07	770	0.10	875	0.12	976	0.15	1071	0.18	1161	0.22	1323	0.28	1469	0.35	1603	0.42
722	1600	698	0.09	795	0.11	893	0.14	990	0.17	1082	0.20	1170	0.23	1330	0.30	1475	0.38	1608	0.45
767	1700	730	0.10	820	0.12	913	0.15	1005	0.18	1094	0.22	1180	0.25	1338	0.33	1481	0.40	1612	0.48
812	1800	763	0.12	848	0.14	935	0.17	1022	0.20	1108	0.23	1191	0.27	1346	0.35	1487	0.43	1618	0.51
857	1900	796	0.13	876	0.16	958	0.19	1041	0.22	1124	0.26	1204	0.29	1356	0.37	1495	0.46	1624	0.54
902	2000	830	0.15	905	0.18	983	0.21	1062	0.24	1141	0.28	1218	0.32	1366	0.40	1504	0.48	1632	0.57
947	2100	864	0.17	936	0.20	1009	0.23	1085	0.26	1159	0.30	1234	0.34	1378	0.42	1513	0.51	1640	0.61
992	2200	899	0.20	967	0.22	1037	0.25	1108	0.29	1180	0.33	1251	0.37	1391	0.45	1523	0.54	1648	0.64
1037	2300	934	0.22	998	0.25	1065	0.28	1133	0.32	1202	0.36	1270	0.40	1405	0.48	1534	0.58	1658	0.68
1082	2400	969	0.25	1030	0.28	1094	0.31	1159	0.35	1225	0.39	1290	0.43	1421	0.52	1547	0.61	1668	0.71
1127	2500	1004	0.28	1063	0.31	1124	0.34	1186	0.38	1249	0.42	1312	0.46	1437	0.55	1561	0.65	1679	0.75

### 105 FCV

Wheel Dia. = 10.625" inches

Outlet Area = 0.594 ft<sup>2</sup>

Max. BHP = 0.85 (RPM÷1000)<sup>3</sup>

CFM	OV	1/8" SP		1/4" SP		3/8" SP		1/2" SP		5/8" SP		3/4" SP		1" SP		1 1/4" SP		1 1/2" SP	
		RPM	BHP	RPM	BHP	RPM	BHP	RPM	BHP	RPM	BHP	RPM	BHP	RPM	BHP	RPM	BHP	RPM	BHP
475	800	404	0.04	519	0.06	617	0.08												
535	900	425	0.04	533	0.07	627	0.10	710	0.12										
594	1000	447	0.05	548	0.08	638	0.11	719	0.14	794	0.17	863	0.20						
653	1100	472	0.07	566	0.10	652	0.13	730	0.16	802	0.19	870	0.23						
713	1200	498	0.08	585	0.11	667	0.14	743	0.18	813	0.22	878	0.25	999	0.33				
772	1300	524	0.10	606	0.13	684	0.16	757	0.20	825	0.24	889	0.28	1006	0.36	1115	0.44		
832	1400	551	0.12	629	0.15	703	0.19	773	0.23	839	0.27	901	0.31	1016	0.39	1121	0.48	1220	0.57
891	1500	579	0.14	653	0.17	723	0.21	790	0.25	854	0.30	914	0.34	1026	0.43	1129	0.52	1226	0.62
950	1600	607	0.16	678	0.20	744	0.24	808	0.28	870	0.33	928	0.37	1038	0.47	1139	0.56	1233	0.66
1010	1700	636	0.19	704	0.23	767	0.27	828	0.32	887	0.36	944	0.41	1051	0.51	1150	0.61	1243	0.71
1069	1800	665	0.22	731	0.26	791	0.31	849	0.35	906	0.40	961	0.45	1065	0.55	1162	0.66	1253	0.77
1129	1900	695	0.25	758	0.30	816	0.34	872	0.39	926	0.44	979	0.49	1080	0.60	1175	0.71	1264	0.83
1188	2000	725	0.29	785	0.34	841	0.39	895	0.44	947	0.49	998	0.54	1096	0.65	1189	0.77	1277	0.89
1247	2100	754	0.33	813	0.38	867	0.43	919	0.48	969	0.54	1018	0.59	1113	0.71	1204	0.83	1290	0.95
1307	2200	785	0.37	841	0.43	894	0.48	944	0.53	992	0.59	1039	0.64	1132	0.77	1220	0.89	1304	1.02
1366	2300	815	0.42	870	0.48	920	0.53	969	0.59	1016	0.65	1061	0.70	1150	0.82	1237	0.96	1319	1.09
1426	2400	846	0.47	899	0.53	948	0.59	995	0.65	1040	0.71	1084	0.77	1170	0.89	1254	1.02	1335	1.16
1485	2500	876	0.53	928	0.59	975	0.65	1021	0.71	1065	0.77	1108	0.83	1191	0.96	1273	1.10	1351	1.24

Performance is for installation Type B & D: Free or ducted inlet, ducted outlet. Power rating (bhp) does not include transmission losses. Performance ratings do not include the effects of appurtenances (accessories).

Class I fans are shown in regular face type. Class II fans are shown in bold face type. Underlined figures indicate maximum static efficiencies.



# Forward Curved

## 182 FCV

Wheel Dia. = 18.25 inches  
Outlet Area = 1.92 ft<sup>2</sup>

Fan Efficiency Grade: FEG71  
Max. BHP = 4.78 (RPM÷1000)<sup>3</sup>

CFM	OV	0.25" SP		0.5" SP		1" SP		1.5" SP		2" SP		2.5" SP		3" SP		3.5" SP		4" SP		4.5" SP		5" SP	
		RPM	BHP	RPM	BHP	RPM	BHP	RPM	BHP	RPM	BHP	RPM	BHP	RPM	BHP	RPM	BHP	RPM	BHP	RPM	BHP	RPM	BHP
1536	800	293	0.11																				
1920	1000	313	0.16																				
2304	1200	339	0.23			566	0.60																
2688	1400	368	0.33	406	0.26	441	0.44	574	0.73														
3072	1600	399	0.46	466	0.58			697	1.22														
3456	1800	432	0.62	494	0.76	605	1.06	708	1.43	804	1.82												
3840	2000	466	0.81	524	0.97	626	1.28	722	1.66	812	2.08	898	2.52										
4224	2200	501	1.04	555	1.22	651	1.56	740	1.93	825	2.37	906	2.84	984	3.33								
4992	2600	572	1.63	620	1.84	706	2.24	785	2.65	861	3.10	934	3.61	1004	4.15	<b>1072</b>	<b>4.71</b>	<b>1138</b>	<b>5.27</b>	<b>1203</b>	<b>5.87</b>		
5760	3000	646	2.43	689	2.68	767	3.15	838	3.60	906	4.07	972	4.58	1036	5.14	<b>1099</b>	<b>5.76</b>	<b>1159</b>	<b>6.38</b>	<b>1219</b>	<b>7.04</b>		
6528	3400	721	3.46	760	3.75	831	4.28	897	4.80	959	5.32	1019	5.86	<b>1078</b>	<b>6.44</b>	<b>1135</b>	<b>7.04</b>	<b>1191</b>	<b>7.69</b>	<b>1246</b>	<b>8.39</b>		
7296	3800	797	4.76	832	5.07	898	5.68	959	6.27	1017	6.85	<b>1072</b>	<b>7.43</b>	<b>1126</b>	<b>8.03</b>	<b>1179</b>	<b>8.66</b>	<b>1230</b>	<b>9.30</b>				

MAXIMUM RPM: Class I — 1046 Class II — 1256

## 200 FCV

Wheel Dia. = 20.00 inches  
Outlet Area = 2.30 ft<sup>2</sup>

Fan Efficiency Grade: FEG71  
Max. BHP = 5.24 (RPM÷1000)<sup>3</sup>

CFM	OV	0.25" SP		0.5" SP		1" SP		1.5" SP		2" SP		2.5" SP		3" SP		3.5" SP		4" SP		4.5" SP		5" SP	
		RPM	BHP	RPM	BHP	RPM	BHP	RPM	BHP	RPM	BHP	RPM	BHP	RPM	BHP	RPM	BHP	RPM	BHP	RPM	BHP	RPM	BHP
1840	800	268	0.13																				
2300	1000	286	0.19	371	0.31																		
2760	1200	309	0.28	384	0.41	517	0.72																
3220	1400	335	0.40	402	0.53	523	0.87																
3680	1600	364	0.55	425	0.70	535	1.05	636	1.46														
4140	1800	394	0.74	450	0.90	551	1.26	645	1.70	733	2.18												
4600	2000	424	0.96	477	1.15	571	1.53	659	1.99	741	2.49	819	3.02										
5060	2200	456	1.24	505	1.45	593	1.86	675	2.31	753	2.85	827	3.41	898	3.99								
5980	2600	521	1.95	565	2.20	643	2.67	716	3.17	785	3.71	852	4.32	916	4.97	<b>978</b>	<b>5.64</b>	<b>1038</b>	<b>6.31</b>	<b>1097</b>	<b>7.02</b>		
6900	3000	588	2.90	627	3.19	699	3.76	764	4.30	826	4.87	886	5.48	945	6.15	<b>1002</b>	<b>6.88</b>	<b>1057</b>	<b>7.63</b>	<b>1112</b>	<b>8.42</b>		
7820	3400	656	4.12	692	4.47	757	5.11	817	5.72	874	6.35	929	7.00	<b>982</b>	<b>7.67</b>	<b>1035</b>	<b>8.42</b>	<b>1086</b>	<b>9.19</b>	<b>1136</b>	<b>10.02</b>		
8740	3800	725	5.66	758	6.06	818	6.78	874	7.49	<b>926</b>	<b>8.16</b>	<b>977</b>	<b>8.87</b>	<b>1026</b>	<b>9.59</b>	<b>1074</b>	<b>10.33</b>	<b>1122</b>	<b>11.14</b>				

MAXIMUM RPM: Class I — 955 Class II — 1146

## 222 FCV

Wheel Dia. = 22.25 inches  
Outlet Area = 2.85 ft<sup>2</sup>

Fan Efficiency Grade: FEG71  
Max. BHP = 5.83 (RPM÷1000)<sup>3</sup>

CFM	OV	0.25" SP		0.5" SP		1" SP		1.5" SP		2" SP		2.5" SP		3" SP		3.5" SP		4" SP		4.5" SP		5" SP	
		RPM	BHP	RPM	BHP	RPM	BHP	RPM	BHP	RPM	BHP	RPM	BHP	RPM	BHP	RPM	BHP	RPM	BHP	RPM	BHP	RPM	BHP
2280	800	241	0.16																				
2850	1000	257	0.24	333	0.39																		
3420	1200	278	0.35	345	0.50	465	0.89																
3990	1400	302	0.50	362	0.66	470	1.07																
4560	1600	327	0.68	382	0.86	481	1.30	572	1.81														
5130	1800	354	0.91	405	1.12	496	1.57	580	2.11	659	2.70												
5700	2000	382	1.20	429	1.43	513	1.90	592	2.46	666	3.09	736	3.73										
6270	2200	410	1.54	455	1.80	533	2.30	607	2.87	677	3.53	743	4.22	807	4.94								
7210	2600	469	2.43	508	2.73	579	3.33	644	3.94	706	4.60	766	5.35	823	6.15	<b>879</b>	<b>6.98</b>	<b>934</b>	<b>7.84</b>	<b>986</b>	<b>8.69</b>		
8550	3000	529	3.60	564	3.96	629	4.67	687	5.33	743	6.05	797	6.80	850	7.64	<b>901</b>	<b>8.53</b>	<b>951</b>	<b>9.48</b>	<b>999</b>	<b>10.42</b>		
9690	3400	591	5.14	622	5.53	681	6.34	735	7.11	786	7.88	835	8.68	<b>883</b>	<b>9.52</b>	<b>930</b>	<b>10.41</b>	<b>976</b>	<b>11.38</b>	<b>1021</b>	<b>12.41</b>		
10830	3800	653	7.05	682	7.52	736	8.42	786	9.29	<b>833</b>	<b>10.13</b>	<b>878</b>	<b>10.98</b>	<b>923</b>	<b>11.91</b>	<b>966</b>	<b>12.82</b>	<b>1009</b>	<b>13.81</b>				

MAXIMUM RPM: Class I — 858 Class II — 1030

## 245 FCV

Wheel Dia. = 24.50 inches  
Outlet Area = 3.45 ft<sup>2</sup>

Fan Efficiency Grade: FEG71  
Max. BHP = 6.41 (RPM÷1000)<sup>3</sup>

CFM	OV	0.25" SP		0.5" SP		1" SP		1.5" SP		2" SP		2.5" SP		3" SP		3.5" SP		4" SP		4.5" SP		5" SP	
		RPM	BHP	RPM	BHP	RPM	BHP	RPM	BHP	RPM	BHP	RPM	BHP	RPM	BHP	RPM	BHP	RPM	BHP	RPM	BHP	RPM	BHP
2760	800	218	0.20																				
3450	1000	233	0.29	302	0.47																		
4140	1200	252	0.42	313	0.61	422	1.08																
4830	1400	274	0.60	328	0.79	427	1.30																
5520	1600	297	0.82	347	1.05	437	1.57	519	2.19														
6210	1800	321	1.10	367	1.35	450	1.89	527	2.56	598	3.26												
6900	2000	346	1.45	389	1.72	466	2.30	538	2.98	605	3.74	669	4.53										
7590	2200	372	1.86	413	2.18	484	2.78	551	3.47	614	4.26	675	5.11	733	5.99								
8970	2600	425	2.92	461	3.30	525	4.01	584	4.75	641	5.57	695	6.46	748	7.46	<b>798</b>	<b>8.44</b>	<b>848</b>	<b>9.49</b>	<b>896</b>	<b>10.54</b>		
10350	3000	480	4.35	512	4.79	570	5.62	623	6.43	674	7.30	724	8.24	771	9.21	<b>818</b>	<b>10.32</b>	<b>863</b>	<b>11.46</b>	<b>907</b>	<b>12.60</b>		
11730	3400	536	6.20	564	6.68	618	7.66	667	8.59	713	9.51	<b>758</b>	<b>10.49</b>	<b>802</b>	<b>11.53</b>	<b>845</b>	<b>12.63</b>	<b>886</b>	<b>13.77</b>	<b>927</b>	<b>15.02</b>		
13110	3800	592	8.50	618	9.06	<b>667</b>	<b>10.14</b>	<b>713</b>	<b>11.21</b>	<b>756</b>	<b>12.25</b>	<b>797</b>	<b>13.28</b>	<b>838</b>	<b>14.41</b>	<b>877</b>	<b>15.51</b>	<b>916</b>	<b>16.71</b>				

MAXIMUM RPM: Class I — 780 Class II — 935

Performance is for installation Type B & D: Free or ducted inlet, ducted outlet.  
Power rating (bhp) does not include transmission losses.  
Performance ratings do not include the effects of appurtenances (accessories).

Class I fans are shown in regular face type.  
Class II fans are shown in **bold** face type.  
Underlined figures indicate maximum static efficiencies.





**DDF**

MODEL NO.	MOTOR HP	RPM	0.125" SP		0.25" SP		0.375" SP		0.5" SP		0.625" SP		0.75" SP		1" SP	
			CFM	OV	CFM	OV	CFM	OV	CFM	OV	CFM	OV	CFM	OV	CFM	OV
DDF60L	1/6	1150	324	1466	254	1149	—	—	—	—	—	—	—	—	—	—
DDF60H	1/6	1750	545	2466	506	2290	464	2100	421	1905	362	1638	292	1321	—	—
DDF75L	1/6	1150	668	2264	586	1986	516	1749	447	1515	—	—	—	—	—	—
DDF75M	1/3	1750	—	—	—	—	—	—	—	—	874	2963	828	2807	741	2512
DDF75H	1/2	1750	1085	3678	1033	3502	978	3315	923	3129	874	2963	828	2807	741	2512
DDF90L	1/3	1150	—	—	1216	2916	1129	2707	1042	2499	946	2269	802	1923	—	—
DDF90M	1/2	1150	1300	3118	1216	2916	1129	2707	1042	2499	946	2269	802	1923	—	—
DDF90J	1½	1750	2048	4911	1994	4782	1940	4652	1886	4523	1830	4388	1772	4249	1657	3974
DDF105L	1	1150	2127	3648	2036	3492	1945	3336	1855	3182	1766	3029	1681	2883	1484	2545

MODEL NO.	MOTOR HP	RPM	1" SP		1.25" SP		1.5" SP		1.75" SP	
			CFM	OV	CFM	OV	CFM	OV	CFM	OV
DDF90H	1	1750	—	—	1543	3700	1408	3376	1205	2890
DDF90J	1½	1750	1657	3974	1543	3700	1408	3376	1205	2890

Model DDF is not licensed to bear the AMCA Seal.

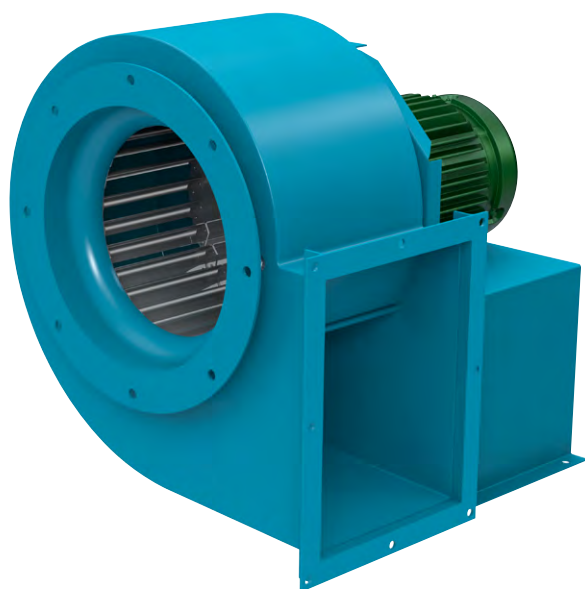

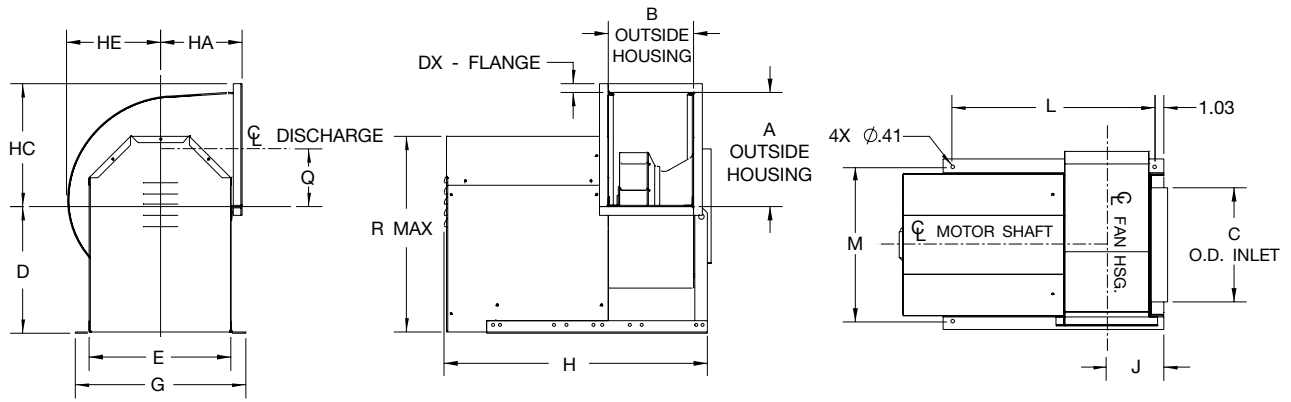

CW THD

FOUNDATION PLAN

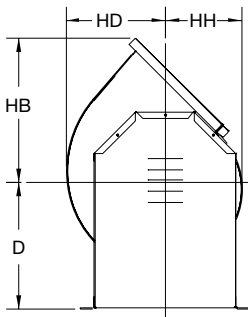

CW TAU

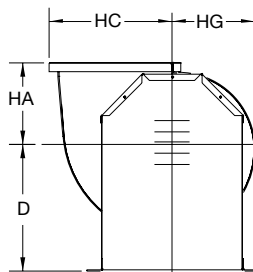

CW UBD

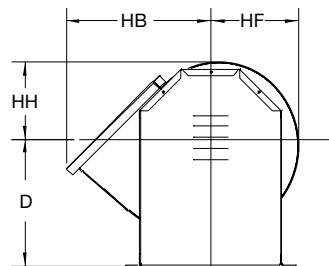

CW BAU

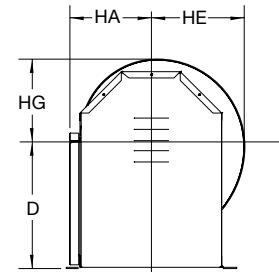

CW BHD

SIZE	A	B	C	D	DX	E	G	H	HA	HB	HC	HD	HE	HF	HH	J	L	M	Q	R	
<b>90-105</b>	11.24	8.59	11.13	14.5	1.00	16.18	19.50	28.55	9.06	15.07	12.24	9.74	9.17	8.64	8.10	7.57	5.92	21.44	17.75	5.61	22.43
<b>122</b>	13.05	9.72	13.13	14.5	1.00	16.18	19.50	30.18	9.31	16.52	14.05	11.34	10.67	10.04	9.42	8.79	6.49	23.13	17.75	6.52	22.43
<b>135</b>	14.37	10.78	14.25	15.75	1.00	17.68	21.00	31.24	10.31	18.16	15.37	12.47	11.73	11.04	10.35	9.67	7.02	24.19	19.25	7.18	24.43
<b>150</b>	15.93	11.90	15.75	17.75	1.00	19.18	22.50	33.43	11.50	20.10	16.93	13.79	12.98	12.23	11.48	10.73	7.58	26.38	20.75	7.96	27.18
<b>165</b>	17.49	13.15	17.50	19.00	1.00	20.68	24.00	34.68	12.69	22.05	18.49	15.11	14.23	13.42	12.60	11.79	8.20	27.63	22.25	8.74	29.18
<b>182</b>	19.43	14.53	19.25	21.00	1.25	22.68	26.00	36.06	14.06	24.57	20.68	16.80	15.79	14.85	13.92	12.98	8.89	29.01	24.25	9.71	32.18
<b>200</b>	21.24	15.90	21.31	22.75	1.25	25.18	28.50	38.43	15.37	26.78	22.49	18.55	17.42	16.35	15.29	14.23	9.58	31.38	26.75	10.61	35.18

33370140C

DIMENSIONS ARE SUBJECT TO CHANGE. CERTIFIED DRAWINGS AVAILABLE UPON REQUEST.

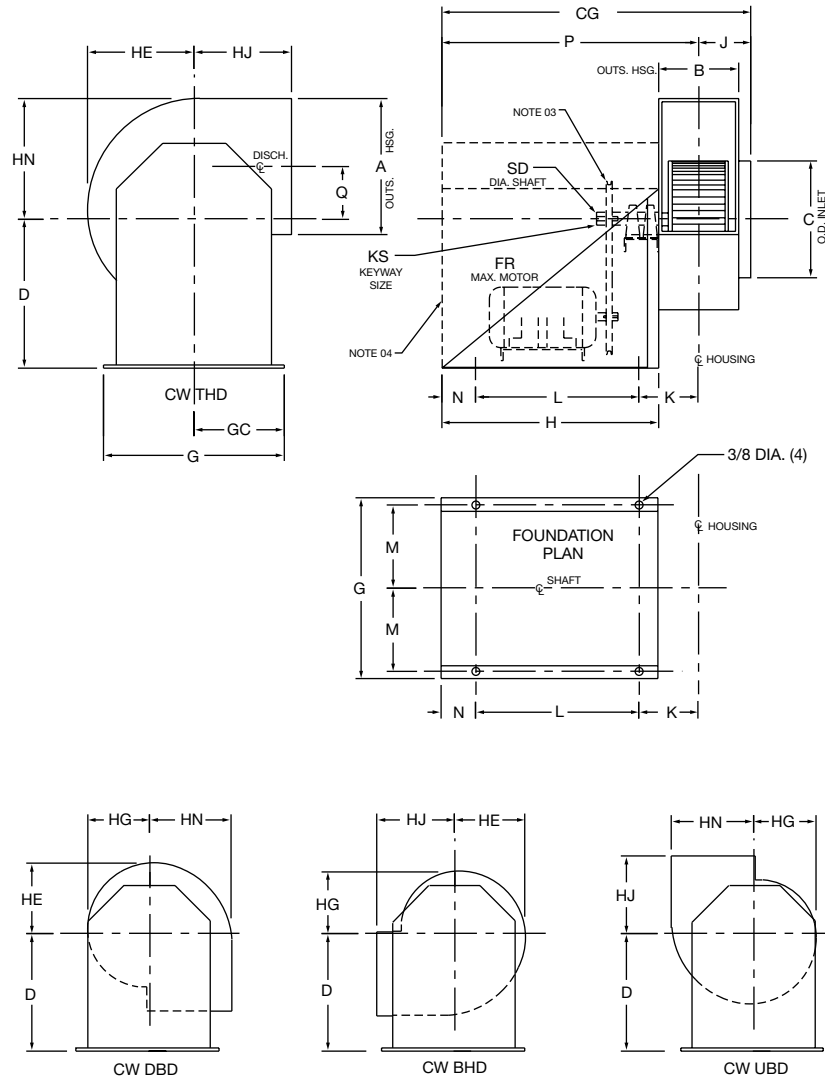

**NOTES:**

1. Housing sides and scroll are 14 GA.
2. 'CW' rotation is shown. 'CCW' rotation is similar but opposite.
3. Package includes adjustable speed v-belt drive.
4. Optional weather cover shown.
5. Optional inlet screens per AS15506.

SIZE	A	B	C	CG	D	FR	G	GC	H	HE	HG
75	8.50	5.00	7.50	25.19	13.00	56	12.25	6.13	18.88	6.56	5.81
90	10.00	6.00	9.00	26.19	13.00	56	14.00	7.00	18.88	8.00	6.81

SIZE	HJ	HN	J	K	KS	L	M	N	P	Q	SD
75	6.13	7.88	3.56	3.69	.19 x .09	14.75	5.63	3.06	21.63	3.63	0.625
90	7.00	9.25	4.06	4.19	.19 x .09	14.75	6.50	3.06	22.13	4.25	0.625

AC10748B

DIMENSIONS ARE SUBJECT TO CHANGE. CERTIFIED DRAWINGS AVAILABLE UPON REQUEST.

**FCV (Size 105)**

**BCV (Class I & II, Sizes 90 – 105)**

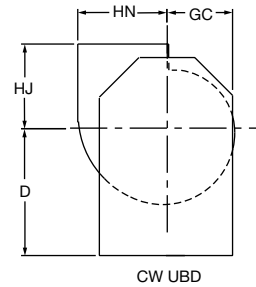
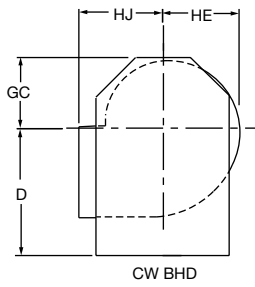
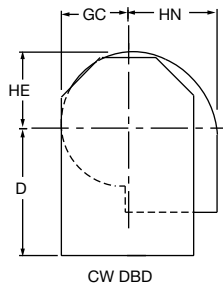
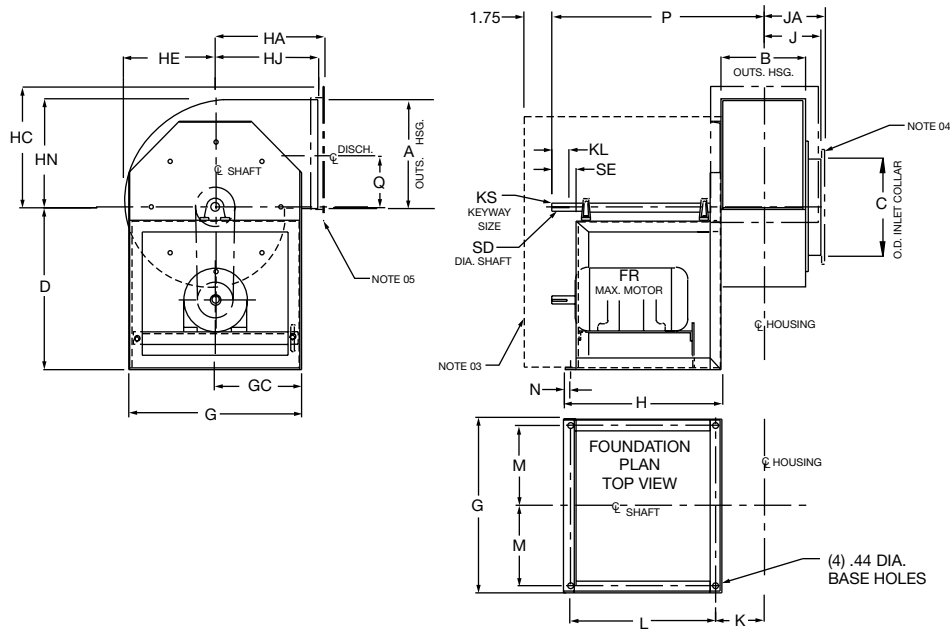

**NOTES:**

1. Housing sides and scroll are 14 GA.
2. 'CW' rotation is shown. 'CCW' rotation is similar but opposite.
3. Optional weather cover shown.
4. Optional inlet flange per AS12403 (FCV).
5. Optional discharge flange per AC14986 (BCV) & AS11741 (FCV).
6. Optional inlet screens per AS15506.

SIZE	A	B	C	D	FR	G	GC	H	HA	HC	HE	HJ	HN
90 BCV	11.19	8.63	10.75	14.50	145T	16	8	13.44	9.50	12.13	9.06	9	11.13
105 BCV	11.19	8.63	10.75	14.50	145T	16	8	13.44	9.50	12.13	9.06	9	11.13
105 FCV	12.00	7.00	10.50	14.50	145T	16	8	13.44	9.50	11.56	9.38	9	10.56

SIZE	J	JA	K	KL	KS	L	M	N	P	Q	SD	SE
90 BCV	5.38	5.50	5.19	2	.25 x .13	12	6.75	0.56	19.19	5.53	1.00	2.75
105 BCV	5.38	5.50	5.19	2	.25 x .13	12	6.75	0.56	19.19	5.53	1.00	2.75
105 FCV	4.56	4.69	4.38	2	.25 x .13	12	6.75	0.56	18.38	4.56	1.00	2.75

AC13485E

DIMENSIONS ARE SUBJECT TO CHANGE. CERTIFIED DRAWINGS AVAILABLE UPON REQUEST.

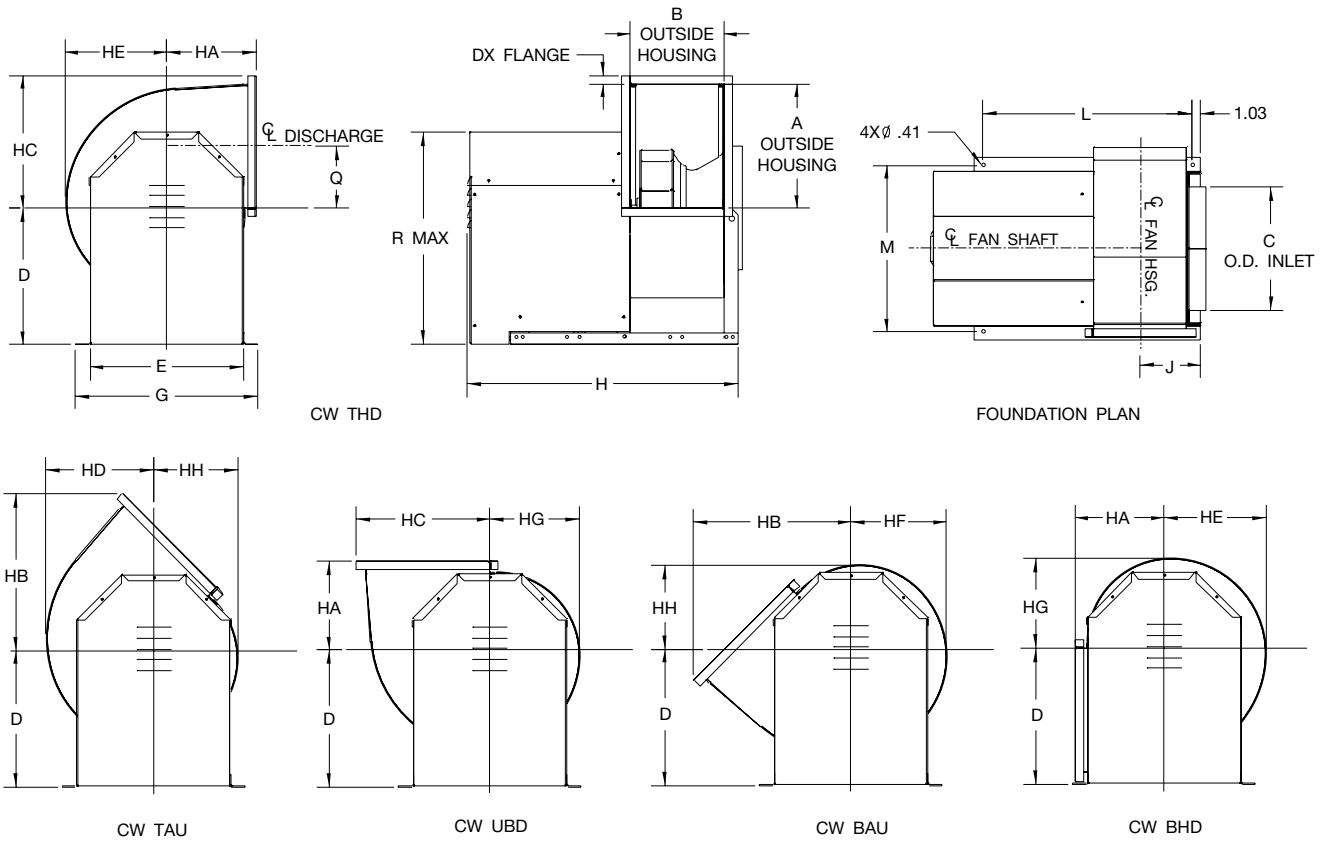

SIZE	A	B	C	D	DX	E	FR	G	H	HA	HB	HC	HD	HE	HF	HG	HH	J	L	M	Q	R
90-105	11.24	8.59	11.13	14.50	1.00	16.18	56	19.50	28.55	9.06	15.07	12.24	9.74	9.17	8.64	8.10	7.57	5.95	21.50	17.75	5.61	22.43
122	13.05	9.72	13.13	14.50	1.00	16.18	143T	19.50	30.18	9.31	16.52	14.05	11.34	10.67	10.04	9.42	8.79	6.49	23.13	17.75	6.52	22.43
135	14.37	10.78	14.25	15.75	1.00	17.68	143T	21.00	31.24	10.31	18.16	15.37	12.47	11.73	11.04	10.35	9.67	7.02	24.19	19.25	7.18	24.43
150	15.93	11.90	15.75	17.75	1.00	19.18	145T	22.50	33.43	11.50	20.10	16.93	13.79	12.98	12.23	11.48	10.73	7.58	26.38	20.75	7.96	27.18
165	17.49	13.15	17.50	19.00	1.00	20.68	145T	24.00	34.68	12.69	22.05	18.49	15.11	14.23	13.42	12.60	11.79	8.20	27.63	22.25	8.74	29.18
182	19.43	14.53	19.25	21.00	1.25	22.68	145T	26.00	36.06	14.06	24.57	20.68	16.80	15.79	14.85	13.92	12.98	8.89	29.01	24.25	9.71	32.18
200	21.24	15.90	21.31	22.75	1.25	25.18	182T	28.50	38.43	15.38	26.78	22.49	18.55	17.42	16.35	15.29	14.23	9.58	31.38	26.75	10.61	35.18
222	23.62	17.59	23.94	25.50	1.25	27.43	184T	31.75	41.68	17.25	29.78	24.87	20.39	19.17	18.04	16.92	15.79	10.42	34.63	29.75	11.80	39.06
245	25.99	19.34	26.00	28.00	1.25	29.93	184T	34.25	43.44	19.06	32.74	27.24	22.45	21.10	19.85	18.60	17.35	11.31	36.39	32.25	12.99	42.81
270	28.68	21.28	28.38	30.50	1.50	33.18	184T	37.50	45.38	21.00	36.19	30.18	24.78	23.29	21.92	20.54	19.17	12.28	38.33	35.50	14.33	46.93

33370142B

DIMENSIONS ARE SUBJECT TO CHANGE. CERTIFIED DRAWINGS AVAILABLE UPON REQUEST.

BCV (Class I & II, Sizes 122 – 365)

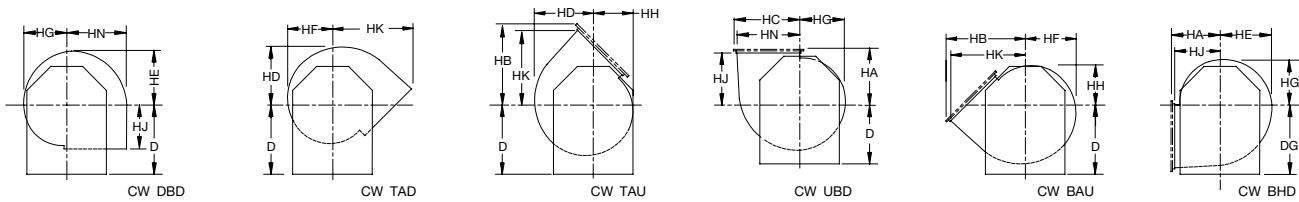
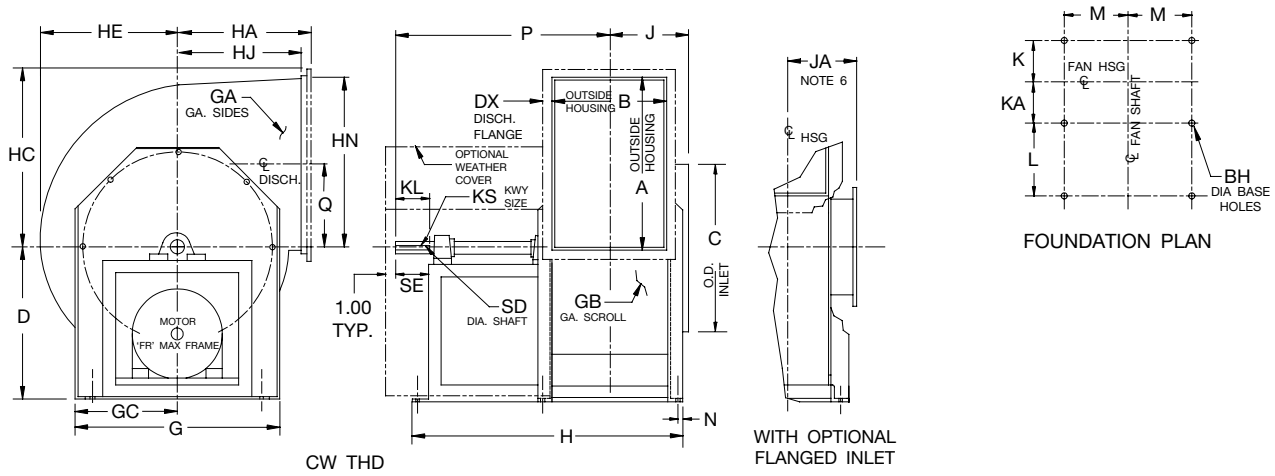

NOTES:

1. Flanged outlet is optional on Sizes 122-200. Flanged outlet is standard on Sizes 222-365 (except on TAD & DBD).
2. 'CW' rotation is shown. 'CCW' rotation is similar but opposite.
- \* 3. Shaft diameter is increased to 1.187 on Hi-temp. fans which require shaft coolers.
4. All units are rotatable to all positions (except Sizes 300-365 with "D" centerline height are not rotatable to BHD).
5. 'FL' is NEMA 'C' max motor length.
6. Optional inlet flange punching per AS363.

SIZE	A	B	BH	C	D		DG		DX	FL	FR	G	GA	GB	GC	H		HA	HB	HC	HD	HE	HF	HG
					CL I	CL II	CL I	CL II								CL I	CL II							
122	13.00	9.75	0.44	13.13	14.50	17.63	14.50	17.63	1.00	14.75	145T	16.00	14	14	8.00	24.50	32.00	9.75	16.75	13.94	11.19	10.56	9.94	9.31
135	14.31	10.81	0.44	14.25	15.75	19.13	15.75	19.13	1.00	14.75	145T	17.50	14	14	8.75	25.63	34.81	10.75	18.38	15.25	12.31	11.63	10.94	10.25
150	15.88	11.94	0.44	15.75	17.75	19.38	17.75	19.38	1.00	17.00	184T	19.00	14	14	9.50	28.75	36.00	11.94	20.31	16.81	13.75	12.88	12.13	11.38
165	17.44	13.19	0.44	17.50	19.00	19.38	19.00	19.38	1.00	17.00	184T	20.50	14	14	10.25	30.13	37.31	13.13	22.25	18.38	15.06	14.13	13.31	12.50
182	19.38	14.56	0.44	19.25	21.00	21.88	21.00	21.88	1.25	20.50	215T	22.50	12	14	11.25	34.38	43.44	14.50	24.81	20.56	16.69	15.69	14.75	13.81
200	21.19	15.94	0.56	21.31	22.75	22.75	22.75	22.75	1.25	20.50	215T	25.00	12	14	12.50	35.75	44.81	15.81	27.00	22.38	18.38	17.31	16.25	15.19
222	23.56	17.69	0.56	23.94	25.50	25.50	25.50	25.50	1.25	18.75	215T	27.25	12	14	13.63	40.75	47.13	17.69	30.00	24.75	20.44	19.06	17.94	16.81
245	25.94	19.44	0.56	26.00	28.00	28.00	28.00	28.00	1.25	19.75	215T	29.75	12	14	14.88	43.50	48.81	19.50	33.00	27.13	22.38	21.00	19.75	18.50
270	28.63	21.38	0.56	28.25	30.50	30.50	30.50	30.50	1.50	21.75	215T	33.00	12	14	16.50	47.38	53.00	21.44	36.44	30.06	24.69	23.19	21.81	20.44
300	31.81	23.81	0.56	31.63	27.50	27.50	34.25	34.25	1.50	24.50	215T	36.13	10	12	18.06	52.88	56.00	23.81	40.31	33.25	27.44	25.75	24.25	22.75
330	35.13	26.06	0.56	34.75	30.00	30.00	37.25	37.25	1.50	26.00	256T	38.88	10	12	19.44	56.13	61.75	26.25	44.44	36.56	30.13	28.38	26.69	25.00
365	38.75	28.88	0.56	38.50	33.50	33.50	41.00	41.00	1.50	32.25	286T	43.75	10	12	21.88	64.56	64.56	29.00	48.88	40.13	33.50	31.50	29.63	27.75

SIZE	HH	HJ	HK	HN	J	JA	K	KA	KL	KS		L		M	N	P		Q	SD		SE		MAX. MTR.	
										CL I	CL II	CL I	CL II			CL I	CL II		CL I	CL II	CL I	CL II	CL I	CL II
122	8.69	9.25	15.69	12.94	7.44	11.44	5.75	5.75	2.00	.25x.13	.25x.13	12.00	18.50	6.75	0.50	19.75	26.50	6.44	1.000	1.187	2.75	2.75	145T	184T
135	9.56	10.25	17.31	14.25	8.00	12.00	6.31	6.31	2.00	.25x.13	.25x.13	12.00	20.25	7.38	0.50	20.31	29.56	7.13	1.000	1.187	2.75	3.38	145T	215T
150	10.63	11.44	19.25	15.81	9.06	12.56	6.88	6.88	2.50	.25x.13	.25x.13	13.88	20.25	8.25	0.50	23.13	30.13	7.88	1.000	1.187	3.25	3.38	184T	215T
165	11.69	12.63	21.19	17.38	9.69	13.19	7.50	7.50	2.50	.25x.13	.25x.13	13.88	20.00	8.75	0.63	23.75	30.75	8.69	1.000*	1.187	3.25	3.38	184T	215T
182	12.88	14.00	23.56	19.31	10.88	13.94	8.19	8.19	3.00	.25x.13	.38x.19	16.75	24.75	9.63	0.63	27.94	36.81	9.63	1.187	1.437	3.75	4.00	215T	256T
200	14.13	15.31	25.75	21.13	11.56	14.63	8.88	8.88	3.00	.38x.19	.38x.19	16.75	24.63	10.63	0.63	28.63	37.50	10.56	1.437	1.437	3.75	4.00	215T	256T
222	15.69	17.19	28.75	23.50	12.44	15.50	10.00	10.00	3.00	.38x.19	.38x.19	19.00	23.88	11.13	0.88	27.63	38.38	11.75	1.437	1.437	3.75	4.00	215T	256T
245	17.25	19.00	31.75	25.88	13.31	16.38	10.88	10.88	3.00	.38x.19	.38x.19	20.00	23.88	11.63	0.88	29.00	39.25	12.94	1.437	1.687	3.75	4.00	215T	256T
270	19.06	20.94	35.00	28.56	14.25	17.31	11.81	11.81	3.25	.38x.19	.38x.19	22.00	26.13	13.13	0.88	31.69	43.13	14.25	1.437	1.687	4.00	4.63	215T	286T
300	21.25	23.31	38.94	31.75	15.50	15.50	13.31	13.31	3.00	.50x.25	.50x.25	24.00	25.38	12.13	1.13	40.38	44.44	15.81	1.937	1.937	3.75	4.63	215T	286T
330	23.31	25.75	43.00	35.06	16.63	16.63	14.44	14.44	3.00	.50x.25	.50x.25	25.00	28.88	12.13	1.13	42.50	49.69	17.50	1.937	2.187	3.75	5.25	256T	326T
365	25.88	28.50	47.44	39.63	18.00	18.00	15.81	17.63	4.00	.50x.25	.63x.31	28.88	28.88	14.13	1.13	50.56	51.06	19.25	1.937	2.437	4.75	5.25	286T	326T

AC9260N

DIMENSIONS ARE NOT TO BE USED FOR CONSTRUCTION. CERTIFIED DRAWINGS AVAILABLE UPON REQUEST.

BCV (Class I & II, Sizes 402 – 600)

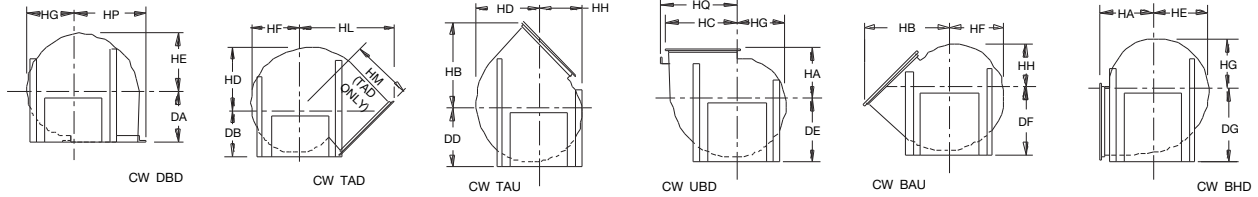
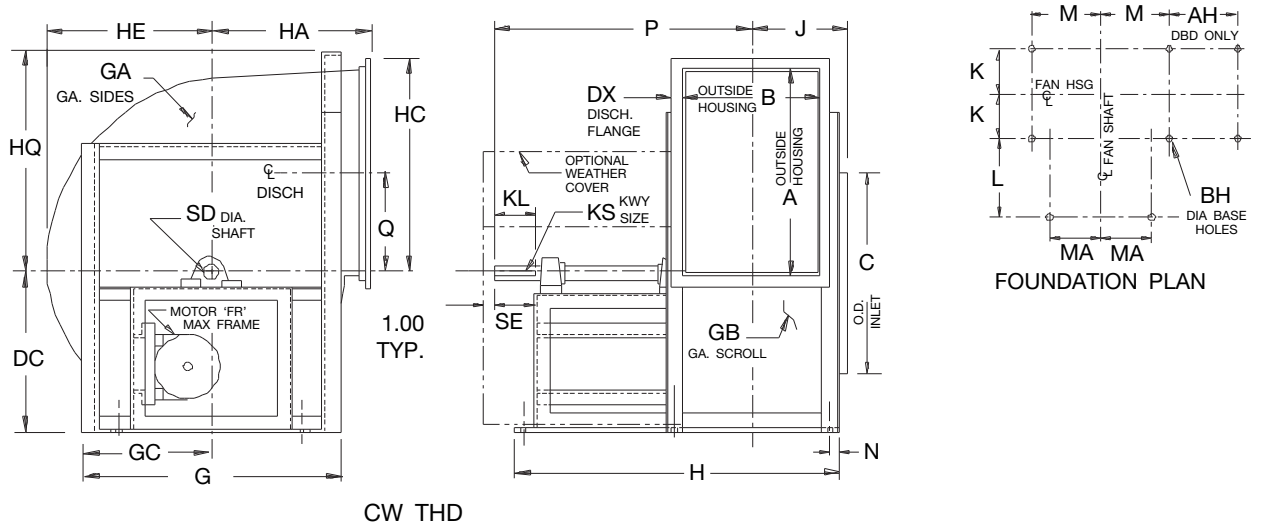

NOTES:

1. Discharge angles are included on all discharges.
2. 'CW' rotation is shown. 'CCW' rotation is similar but opposite.
3. Frame supports vary in construction by size and by discharge position.
4. 'FL' is NEMA 'C' max motor length.

SIZE	A	AH	B	BA	BH	C	DA	DB	DC	DD	DE	DF	DG	DX	FL	FR	G	GA	GB	GC	H	HA	HB	HC
402	42.63	23.31	31.81	3.0x3.0	0.81	42.44	32.00	31.75	33.00	35.25	37.00	39.50	45.50	1.50	29.75	286T	52.50	10	12	26.25	67.88	32.00	53.81	44.06
445	47.13	25.81	35.19	3.0x3.0	0.81	46.88	35.38	36.25	35.50	38.50	40.00	43.25	50.00	1.50	29.75	286T	56.50	10	12	28.25	71.25	35.38	59.38	48.56
490	51.94	28.13	38.63	3.0x3.0	0.81	51.63	39.00	38.75	39.00	42.25	44.00	47.50	54.75	2.00	29.75	326T	61.50	10	12	30.75	74.63	39.00	65.69	53.88
542	57.38	31.81	42.88	3.0x4.0	0.81	57.13	43.06	42.25	43.50	46.50	49.00	52.25	60.25	2.00	35.75	365T	67.00	10	12	33.50	86.88	43.06	72.38	59.31
600	63.50	34.94	47.31	3.0x4.0	0.81	63.13	47.69	45.00	48.00	51.25	54.00	57.50	66.25	2.00	35.75	365T	73.00	10	12	36.50	91.38	47.69	80.00	65.44

SIZE	HD	HE	HF	HG	HH	HL	HM	HP	HQ	J	K	KL	KS		L	M	MA	N	P	Q	SD		SE
													CL I	CL II							CL I	CL II	
402	37.00	34.69	32.63	30.56	28.50	60.50	41.56	45.56	-	20.00	17.56	3.50	.50x.25	.63x.31	30.00	20.88	13.63	1.38	45.19	21.25	2.187	2.437	4.25
445	40.88	38.25	36.00	33.75	31.50	65.69	44.38	50.06	-	21.69	19.25	3.50	.63x.31	.63x.31	30.00	22.88	13.63	1.38	47.13	23.50	2.437	2.687	4.50
490	44.88	42.19	39.69	37.19	34.69	72.31	48.44	54.88	-	23.38	20.94	3.50	.63x.31	.75x.38	30.00	25.38	13.63	1.38	48.81	25.88	2.687	2.937	4.50
542	49.75	46.69	43.94	41.19	38.44	78.88	52.31	61.31	59.75	26.50	23.56	4.25	.75x.38	.88x.44	36.00	27.63	16.13	1.88	56.94	28.83	2.937	3.437	5.50
600	55.00	51.69	48.63	45.56	42.50	86.25	56.56	67.44	65.75	28.75	25.81	4.25	.75x.38	.88x.44	36.00	30.63	16.13	1.88	59.19	31.69	2.937	3.437	5.50

AC9261H

DIMENSIONS ARE NOT TO BE USED FOR CONSTRUCTION. CERTIFIED DRAWINGS AVAILABLE UPON REQUEST.



DDF (Sizes 60, 75, 90, 105)

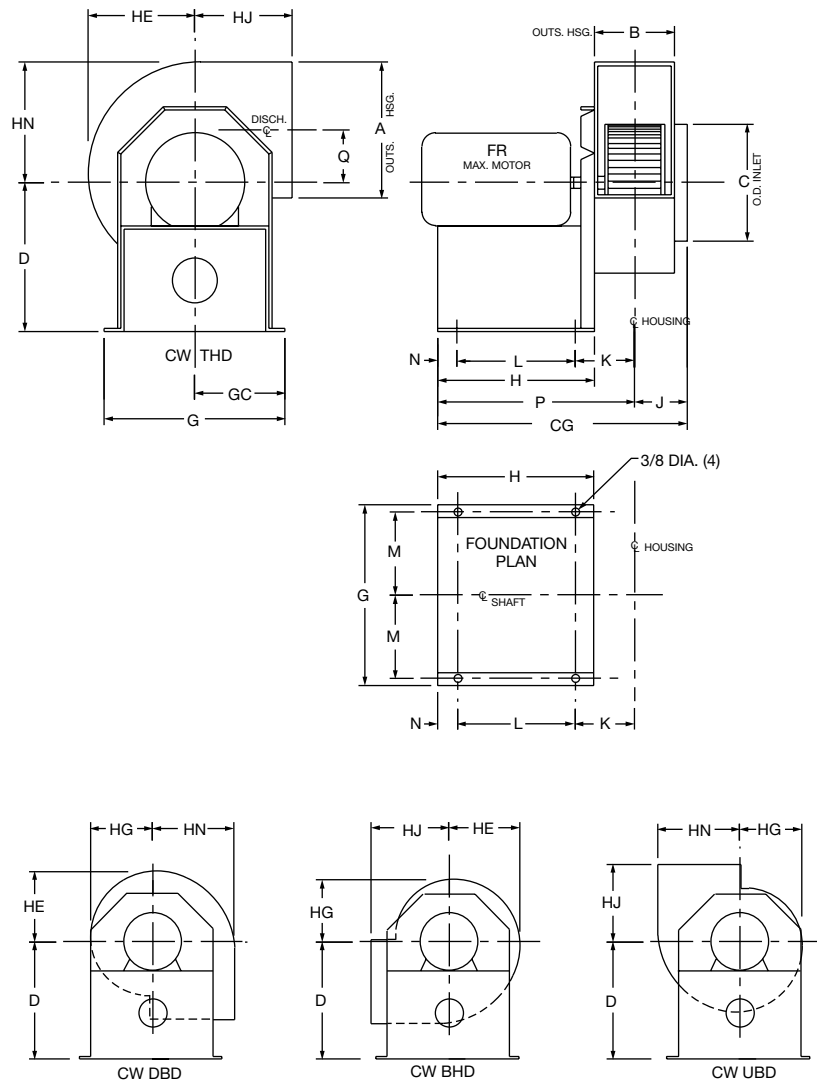

NOTES:

1. Housing sides and scroll are 14 GA.
2. 'CW' rotation is shown. 'CCW' rotation is similar but opposite.
3. Optional inlet screens per AS15506B.

SIZE	A	B	C	CG	D	FR	G	GC	H	HE
60	7.50	4.25	6.00	13.38	8.13	56	9.75	4.88	8.00	5.50
75	8.50	5.00	7.50	14.13	9.75	56	11.25	5.63	8.00	6.56
90	10.00	6.00	9.00	18.13	10.50	145T	12.63	6.31	11.00	8.00
105	12.00	7.00	10.50	20.13	12.63	145T	15.88	7.94	11.00	9.38

SIZE	HG	HJ	HN	J	K	L	M	N	P	Q
60	4.75	5.50	6.63	3.19	3.19	6.00	4.31	1.00	10.19	2.88
75	5.81	6.13	7.88	3.56	3.56	6.00	5.13	1.00	10.56	3.63
90	6.81	7.00	9.25	4.06	4.06	9.00	5.81	1.00	14.06	4.25
105	7.94	9.00	10.56	4.56	4.56	9.00	7.44	1.00	14.56	4.56

AC10804B

DIMENSIONS ARE SUBJECT TO CHANGE. CERTIFIED DRAWINGS AVAILABLE UPON REQUEST.

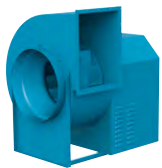

## Models

BCV | DCV | BAV | FCV

Fans shall be Model BCV Backward Inclined, Model DCV Backward Inclined, Model BAV Backward Inclined Airfoil or Model FCV Forward Curved Utility Sets, as manufactured by Twin City Fan & Blower, Minneapolis, Minnesota.

**PERFORMANCE** — Fans shall be tested in accordance with AMCA 211 and AMCA 311 test codes for air moving devices and shall be guaranteed by the manufacturer to deliver rated published performance levels. DCV, BCV and BAV fans shall be licensed to bear the AMCA certified ratings seal for both sound and air, and fan efficiency grade (FEG). FCV fans sizes 122, 135, 150, 165, 182, 200, 222, 245, 270, 300, 330, and 365 shall be licensed to bear the AMCA certified ratings seal for air and fan efficiency grade (FEG).

**HOUSING** — Class I and Class II fan housings shall be heavy gauge, continuously welded construction. Housings with partially welded construction are not acceptable. Class L fan housings shall be lock seam construction. Housings shall be suitably braced to prevent vibration or pulsation. Housings shall have tapered spun, aerodynamically designed inlet cones or shrouds providing stable flow and high rigidity. Class I and Class II housings shall be of the rotatable design, convertible to seven standard discharge configurations. Class L housings shall be of the rotatable design, convertible to five standard discharge configurations.

**WHEELS** — BCV & DCV backward inclined wheels shall be single thickness plate type designed for maximum efficiency and quiet operation and shall be of the non-overloading type. Class I wheels, sizes 90 through 270 and Class L wheels, shall be constructed of aluminum, with blades riveted and welded to the spun wheel cone and backplate. Class I wheels, sizes 300 through 365, and all Class II wheels shall be constructed of heavy gauge steel with welded (not riveted) blades.

BAV backward inclined airfoil wheels shall be of the non-overloading type and include die-formed, airfoil type blades, continuously welded to the wheel cone and backplate. Partial welding will not be acceptable on airfoil blades. Size 245 and smaller use extruded aluminum blades. Sizes 270 and larger shall have die-formed airfoil steel blades.

FCV forward curved wheels shall be constructed of heavy gauge steel and solidly riveted to a steel shroud and backplate.

DDF forward curved wheels shall be constructed of aluminum with blades riveted to the centerplate and wheel outer rim.

All wheels shall be statically and dynamically balanced.

**SHAFT** — Shafts shall be AISI 1045 hot rolled steel, accurately turned, ground, polished, and ring gauged for accuracy. Shafts shall be sized for the first critical speed of at least 1.43 times the maximum speed.

**BEARINGS** — Bearings shall be heavy duty, grease lubricated, anti-friction ball, self-aligning, pillow block type and selected for a minimum average bearing life (AFBMA L-50) in excess of 200,000 hours at the maximum fan RPM.

**DRIVE** — Motor sheaves shall be cast iron, and supplied as either variable pitch or fixed pitch. Drives and belts shall be rated for a minimum of 120% of the required motor HP.

**FINISH AND COATING** — Class I and Class II fan assemblies, excluding the shaft, shall be thoroughly degreased and deburred before application of a rust-preventative primer for Class I and Class II construction. After the fan is completely assembled, a finish coat of paint shall be applied to the entire assembly of Class I and Class II fans. The fan shaft shall be coated with a petroleum-based rust protectant. Galvanized steel and aluminum components shall be unpainted.

**ACCESSORIES** — When specified, accessories such as belt guards, weather covers, access doors, variable inlet vanes, outlet shutters, inlet screens, etc., shall be provided by Twin City Fan & Blower to maintain one source responsibility.

**FACTORY RUN TEST** — All fans prior to shipment shall be completely assembled and test run as a unit at operating speed or maximum RPM allowed for the particular construction type. Each wheel shall be statically and dynamically balanced in accordance with ANSI/AMCA 204-96 "Balance Quality and Vibration Levels for Fans" to Fan Application Category BV-3, Balance Quality Grade G6.3. Balance readings shall be taken by electronic type equipment in the axial, vertical, and horizontal directions on each of the bearings. Records shall be maintained and a written copy shall be available upon request.

**GUARANTEE** — The manufacturer shall guarantee the workmanship and materials for its BCV, DCV, BAV and FCV Utility Sets for at least one (1) year from startup or eighteen (18) months from shipment, whichever occurs first.



## Models

### BCVR | BCVSH

Fans shall be Model BCVR (UL 762) or BCVSH (UL Smoke & Heat) Backward Inclined Utility Sets, as manufactured by Twin City Fan & Blower, Minneapolis, Minnesota.

**PERFORMANCE** — Fans shall be tested in accordance with AMCA 211 and AMCA 311 test codes for air moving devices and shall be guaranteed by the manufacturer to deliver rated published performance levels. BCVR and BCVSH fans shall be licensed to bear the AMCA certified ratings seal for both sound and air.

**HOUSING** — Fan housings shall be heavy gauge, continuously welded construction. Housings with lock seam or partially welded construction are not acceptable. Housings shall be suitably braced to prevent vibration or pulsation. Housings shall have tapered spun, aerodynamically designed inlet cones or shrouds providing stable flow and high rigidity. Housings shall be of the rotatable design, convertible to seven standard discharge configurations.

**WHEELS** — BCV backward inclined wheels shall be single thickness plate type designed for maximum efficiency and quiet operation and shall be of the non-overloading type. BCVR and BCVSH Class I, sizes 90 through 270 and Class L wheels, shall be constructed of aluminum, with blades riveted and welded to the spun wheel cone and backplate. Class I wheels, sizes 300 through 365, and all Class II wheels shall be constructed of heavy gauge steel with welded (not riveted) blades. BCVSH fans shall have steel wheels on all fan sizes.

All wheels shall be statically and dynamically balanced.

**SHAFT** — Shafts shall be AISI 1045 hot rolled steel, accurately turned, ground, polished, and ring gauged for accuracy. Shafts shall be sized for the first critical speed of at least 1.43 times the maximum speed.

**BEARINGS** — Bearings shall be heavy duty, grease lubricated, anti-friction ball, self-aligning, pillow block type and selected for a minimum average bearing life (AFBMA L-50) in excess of 200,000 hours at the maximum fan RPM.

**DRIVE** — Motor sheaves shall be cast iron, and supplied as either variable pitch or fixed pitch. BCVR drives and belts shall be rated for a minimum of 120% of the required motor HP. BCVSH fans shall have drives and belts rated for 150% of the required motor HP with a minimum of two belts.

**FINISH AND COATING** — The entire fan assembly, excluding the shaft, shall be thoroughly degreased and deburred before application of a rust-preventative primer for Class I and Class II construction. After the fan is completely assembled, a finish coat of paint shall be applied to the entire assembly of Class I and Class II fans. The fan shaft shall be coated with a petroleum-based rust protectant. Galvanized steel and aluminum components shall be unpainted.

**ACCESSORIES** — When specified and dependent upon the fan type, accessories such as belt guards, weather covers, access doors, outlet shutters, inlet screens, etc., shall be provided by Twin City Fan & Blower to maintain one source responsibility.

**FACTORY RUN TEST** — All fans prior to shipment shall be completely assembled and test run as a unit at operating speed or maximum RPM allowed for the particular construction type. Each wheel shall be statically and dynamically balanced in accordance with ANSI/AMCA 204-96 "Balance Quality and Vibration Levels for Fans" to Fan Application Category BV-3, Balance Quality Grade G6.3. Balance readings shall be taken by electronic type equipment in the axial, vertical and horizontal directions on each of the bearings. Records shall be maintained and a written copy shall be available upon request.

**GUARANTEE** — The manufacturer shall guarantee the workmanship and materials for its BCVR and BCVSH Utility Sets for at least one (1) year from startup or eighteen (18) months from shipment, whichever occurs first.



## Model DDF

Fans shall be Model DDF Forward Curved Junior Utility Set, as manufactured by Twin City Fan & Blower, Minneapolis, Minnesota.

**PERFORMANCE** - Fans shall be tested in accordance with ANSI/AMCA Standard 210 (air performance) and 300 (sound performance) in an AMCA accredited laboratory. Fans shall have a sharply rising pressure characteristic extending through the operating range and continuing to rise beyond the peak efficiency to ensure quiet and stable operation. Fans shall have a non-overloading design with self-limiting horsepower characteristics and shall reach a peak in the normal selection area. All fans shall be capable of operating over the minimum pressure class limits as specified in AMCA Standard 99.

**HOUSING** - Fan housings shall be of heavy gauge, continuously welded construction. Housings with lock seams or partially welded construction are not acceptable. Housings shall be suitably braced to prevent vibration or pulsation. Housings shall have tapered spun, aerodynamically designed inlet cones or funnels providing stable flow and high rigidity.

**WHEEL** - Forward curved wheels shall be designed for maximum efficiency and quiet operation. Wheels shall be constructed of aluminum, with blades securely riveted to the end rings and center plate. All wheels shall be statically and dynamically balanced.

**FINISH AND COATING** - The entire fan assembly shall be thoroughly degreased and deburred before application of a rust-preventative primer. After the fan is completely assembled, a finish coat of paint shall be applied to the entire assembly.

**ACCESSORIES** - When specified, accessories such as weather cover, access doors, companion flanges, discharge shutters, inlet screens, etc., shall be provided by Twin City Fan & Blower to maintain one source responsibility.

**FACTORY BALANCE AND RUN TESTING** - All fan wheels shall be statically and dynamically balanced in accordance with ANSI/AMCA 204 "Balance Quality and Vibration Levels for Fans" to Fan Application Category BV-3. This corresponds to a Balance Quality Grade G6.3. All assembled fans are test run at the rated operating speed or at the maximum RPM of the fan. Vibration readings are recorded in the horizontal, vertical and axial directions on both bearings. Trim balancing is performed if necessary to maintain BV-3 vibration limits. Records shall be maintained and a written copy shall be available upon request.

**GUARANTEE** - The manufacturer shall guarantee the workmanship and materials for its DDF Forward Curved Junior Utility Sets for at least one (1) year from startup or eighteen (18) months from shipment, whichever occurs first.



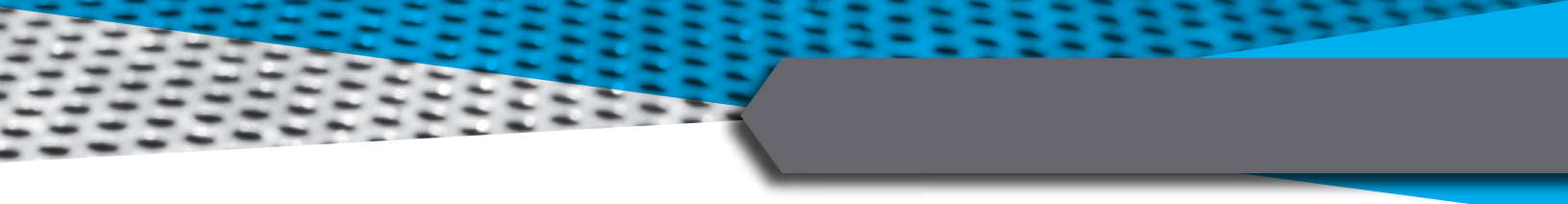

# INDUSTRIAL PROCESS AND COMMERCIAL VENTILATION SYSTEMS

CENTRIFUGAL FANS | UTILITY SETS | PLENUM & PLUG FANS | INLINE CENTRIFUGAL FANS  
MIXED FLOW FANS | TUBEAXIAL & VANEAXIAL FANS | PROPELLER WALL FANS | PROPELLER ROOF VENTILATORS  
CENTRIFUGAL ROOF & WALL EXHAUSTERS | CEILING VENTILATORS | GRAVITY VENTILATORS | DUCT BLOWERS  
RADIAL BLADED FANS | RADIAL TIP FANS | HIGH EFFICIENCY INDUSTRIAL FANS | PRESSURE BLOWERS  
LABORATORY EXHAUST FANS | FILTERED SUPPLY FANS | MANCOOLERS | FIBERGLASS FANS | CUSTOM FANS



**TWIN CITY FAN & BLOWER**  
**[WWW.TCF.COM](http://WWW.TCF.COM)**

5959 TRENTON LANE N | MINNEAPOLIS, MN 55442 | PHONE: 763-551-7600 | FAX: 763-551-7601

©2018 Twin City Fan Companies, Ltd., Minneapolis, MN. All rights reserved. Catalog illustrations cover the general appearance of Twin City Fan & Blower products at the time of publication and we reserve the right to make changes in design and construction at any time without notice.