



WASHINGTON ASSOCIATION OF BUILDING OFFICIALS

**WABO
WELDER AND WELDING OPERATOR
PERFORMANCE QUALIFICATION
STANDARD
FOR**

- **STRUCTURAL STEEL**
- **SHEET STEEL**
- **REINFORCING STEEL**
- **SEISMIC RESTRICTED ACCESS**

**WABO Standard No. 27-13
Seventh Edition**

Effective December 2014

FOREWARD

This seventh edition of the *Welder and Welding Operator Performance Qualification Standard* No. 27-13 updates and replaces previous editions of this Standard and reflects the applicable requirements and intent of most recent editions of the *Washington State Building Code; Structural Welding Code-Steel (ANSI/AWS D1.1); Structural Welding Code – Seismic Supplement (ANSI/AWS D1.8); Structural Welding Code-Sheet Steel (ANSI/AWS D1.3)* and the *Structural Welding Code-Reinforcing Steel (ANSI/AWS D1.4)*.

This Standard has been compiled through the joint efforts of members of the Washington Association of Building Officials (WABO) and members of the American Welding Society (AWS).

This Standard has been published as follows:

1st edition November 1980

2nd edition May 1982

3rd edition May 1989

4th edition October 2002

5th edition July 2008

6th edition November 2013

7th edition December 10, 2014

Washington Association of Building Officials

PO Box 7310

Olympia, Washington 98507-7310

(360) 628-8669

Toll Free: 888-664-9515

Fax: 360-918-8021

E-mail: wabo@wabo.org

Web page: www.wabo.org

PREFACE

The Washington Association of Building Officials (WABO) is a nonprofit corporation established to research, develop, and promote the uniform implementation and enforcement of building codes in the State of Washington. The Association's membership includes building officials from jurisdictions at all levels (state, county, city, and town) who are responsible for administering and enforcing building codes.

Building codes adopted within the State of Washington include requirements for qualifications of welders. To provide greater confidence in compliance with these requirements, WABO Standard 27-13 establishes uniform qualification and testing procedures for certification of welders, welding operators, and tackers.

TABLE OF CONTENTS

Section	Topic	Page
21-13.1	Purpose.....	5
27-13.2	Scope.....	5
27-13.3	Welder Qualifying Agency Requirements.....	5
27-13.4	Welder Certification.....	7
27-13.5	Welder Qualification General Requirements.....	9
27-13.6	Welder Qualification Tests	10
27-13.7	Qualification Tests Required and Limitations	13
27-13.8	Visual Inspection Criteria for Acceptance	13
27-13.9	Test Specimens, Root, Face, or Side-bend	15
27-13.10	Methods of Testing Specimens.....	15
27-13.11	Technical Inquiries.....	17
27-13.12	Challenges and Appeals.....	17
27-13.13	Suspension and Withdrawals	18
	List of Figures	19
	List of Tables	46
27-13-Q	Terms and Definitions.....	59
	Sample Welding Procedure Specifications.....	68

SECTION 27-13.1 - PURPOSE

The purpose of this Standard is to provide greater confidence to design professionals, owners, and building officials that welders, welding operators, and tackers are qualified to perform the work for which they have been certified for building construction.

Certification of personnel in accordance with this Standard is intended to be part of an overall welding quality assurance program. Other components of welding quality assurance may include but are not limited to the following:

- Approved construction documents
- Contractor quality control
- Approved welding procedures
- Welder qualifications not covered by this Standard
- Material testing
- Building department inspections
- Special inspections
- Structural observation

The qualification tests described in this Standard are not intended to be used as a guide for welding during actual construction, and certification of personnel in accordance with this Standard shall not be used as a substitute for other requirements of welding quality assurance.

SECTION 27-13.2 – SCOPE

The provisions of this Standard shall apply to the qualification and certification of welders, welding operators and tackers performing structural steel, sheet steel, seismic, and reinforcing steel welding. The limitations of welder and welding operator qualifications are found in Table 27-13-I.

SECTION 27-13.3 - WELDER QUALIFYING AGENCY REQUIREMENTS

1. GENERAL

Only WABO Approved Welder Examiners employed at WABO Welder Qualifying Agencies are authorized to perform the welder and welding operator performance qualification tests required by this Standard at WABO approved facilities.

Welder Qualifying Agencies interested in becoming approved by WABO to perform the tests may obtain application forms and information concerning certification by contacting the WABO office or by visiting the WABO website at www.wabo.org.

2. ELIGIBILITY

The following organizations are eligible to become approved WABO Welder Qualifying Agencies:

- 2.1 Independent testing laboratories
- 2.2 Private and public welder vocational training institutions, including those operated by labor unions
- 2.3 Steel fabricator plants certified by the AISC Quality Certification Program
- 2.4 Others granted approval by WABO

3. INSPECTION-EVALUATION

Inspection-Evaluation of welder qualifying agencies will be performed by one or more persons selected by WABO who are knowledgeable in welding and welder qualification. The agency will receive a technical survey of its testing facility and methods of record keeping.

4. CERTIFICATION OF WELDER QUALIFYING AGENCIES

Upon recommendation for certification by the Inspection-Evaluation team, WABO will issue certificates identifying the agency and its key personnel. The agency certificate will be valid for a three year period, subject to periodic reinspections of the agency.

5. AGENCY PERSONNEL

Agency personnel witnessing the tests and approving the mechanical and visual test coupons must be WABO Approved Welder Examiners. Agency personnel can become WABO Approved Welder Examiners by submitting proof that they are an AWS Certified Welding Inspector (CWI) qualified and certified in accordance with the provisions of AWS QCI, Standard for Qualification and Certification of Welding Inspectors and successfully completing the WABO written Welder Examiner Test based on the contents of this Standard. Upon successful completion of the written exam, an Approved Welder Examiner card will be issued. Examiner cards are valid for one year and are required to be renewed annually.

Personnel performing radiographic testing will be qualified in accordance with the current edition of the American Society for Nondestructive Testing Recommended Practice No. SNT-TC-1A. Only individuals qualified for NDT Level II may perform and interpret radiographic testing.

SECTION 27-13.4 - WELDER CERTIFICATION

Welders and welding operators may become certified by WABO in one or more of the following categories and processes by satisfactory completion of the applicable qualification tests described in this Standard.

Following are the welder certification classifications available through the WABO Welder Certification Program.

1. Structural Welder

Process	Method
Shielded Metal Arc Welding (SMAW)	Manual
Gas Tungsten Arc Welding (GTAW)	Manual
Gas Metal Arc Welding (GMAW)	Semi-automatic
Flux Cored Arc Welding (FCAW)	Semi-automatic

2. Sheet Steel Welder

Process	Method
Shielded Metal Arc Welding (SMAW)	Manual
Gas Tungsten Arc Welding (GTAW)	Manual
Gas Metal Arc Welding (GMAW)	Semi-automatic
Flux Cored Arc Welding (FCAW)	Semi-automatic

3. Welding Operator

Process	Method
Submerged Arc Welding (SAW)	Automatic

4. Reinforcing Steel Welder

Process	Method
Shielded Metal Arc Welding (SMAW)	Manual
Gas Metal Arc Welding (GMAW)	Semi-automatic
Flux Cored Arc Welding (FCAW)	Semi-automatic

5. Seismic Restricted Access Welder

(Prerequisite: WABO Certification for Field Structural Welder)

Process	Method
Shielded Metal Arc Welding (SMAW)	Manual
Flux Cored Arc Welding (FCAW)	Semi-automatic

6. WELDER CERTIFICATES

- 6.1 Welder certificates are issued for a period of one year. For certifications to remain valid, the welder must have the certificate endorsed by his/her supervisor or designee, or by a WABO Approved Welding Examiner. The endorser shall have witnessed the individual's welding during the calendar quarter being endorsed.
- 6.2 To renew the certificate, the welder must return the certification card and properly endorsed signature form to WABO and pay a renewal fee.
- 6.3 The qualification of the welder or welding operator shall remain in effect indefinitely unless:
 - 6.3.1 The welder or welding operator is not engaged in the weld process for which he/she is qualified for a period exceeding six (6) months, in which case a new qualification test shall be required.
 - 6.3.2 There is some specific reason to question a welder or welding operator's ability, in which case, a new qualification test may be required. In the event the welder or welding operator fails to pass the new qualification test, certification shall be suspended until he/she can successfully complete the welding test.
 - 6.3.3 The welder fails to renew his/her certification on or before the expiration date. EXCEPTION: An expired certification may be reinstated within sixty (60) days after the expiration date. Thereafter, a new qualification test shall be required.
 - 6.3.4 Certification for Seismic Restricted Access Welder shall remain valid for 36 months, providing the continuity requirements for process use outlined above are met. After 36 months a new qualification test is required.

6.4 Welder Certification Revocation

Each certification card carries the statement "This card is the property of WABO," which entitles all possession rights to WABO, thereby extending authority beyond the officers, executive board and program managers to any representative acting on behalf of WABO, i.e. building officials, inspectors, and examiners to confiscate any certification card for probable cause. Confiscated certification cards must be forwarded to the WABO office, accompanied by a written explanation of circumstances, within five (5) working days of the infraction date.

Any Certificate issued by WABO for certification and registration programs presented as qualification by an individual:

- 6.4.1 Other than the certificate holder, for any reason, will deem any and all WABO certificates held by the certificate holder revoked for a period of not less than three (3) years from the date of infraction.
- 6.4.2 The person presenting another certificate holders certificate, for any reason, will also automatically have any and all WABO certificates revoked for a period of not less than three (3) years from the date of infraction.

- 6.4.3 If the person presenting another individual's certificate is not currently certified by WABO, that person will be prohibited from obtaining any WABO certification for a period of not less than three (3) years from the date of infraction.
- 6.4.4 Altered certificates, other than those approved and currently on file at WABO carry the same three (3) year revocation provision.

Section 27-13.5 - WELDER QUALIFICATION GENERAL REQUIREMENTS

1. KNOWLEDGE AND ABILITY

- 1.1 **Work Performance.** Each welder and welding operator shall perform one or more test welds on prepared test coupons in accordance with the following:
 - 1.1.1 Welding machines shall be set at zero or minimum setting prior to the welder or welding operator adjusting the machine.
 - 1.1.2 Prior to welding, each test weldment shall be identified by placing a welder or welding operator identification mark and laboratory test number on the test weldment for each process and position.
 - 1.1.3 Each specimen removed from the test weldment shall be stamped with laboratory test number and specimen number.
 - 1.1.4 Test weldments may not be removed from position during the test.
 - 1.1.5 Cleaning and removal of slag, undercut and excess bead convexity between passes is acceptable if made in position with the approval of the Welder Examiner.
 - 1.1.6 Grinding of root and cover passes not permitted.
 - 1.1.6.1 Root pass grinding on pipe is acceptable with permission of the Welder Examiner.

2. RECORDS

A complete record shall be made of the tests performed by each welder or welding operator, and of the results of those tests.

Original copies shall be forwarded by the Welder Examiner to the WABO office within thirty (30) days, together with the application and processing fee.

A copy of each record shall be kept by the Welder Examiner, at the qualifying agency, for a period of three (3) years. Bend test specimens and radiographic specimens shall be retained by the Welder Examiner, at the qualifying agency, for a period of six (6) months. Copies of radiograph reports shall be forwarded to the WABO office with the original record. The original copies of the tests shall be kept for current welders at the WABO office indefinitely.

Certificates shall be issued by the WABO office. A roster of currently certified welders and welding operators shall be kept at the WABO office.

Records and specimens shall be available to those authorized by WABO to examine them. Visual specimens and bend specimens shall be maintained securely fastened together with identification stamping clearly visible.

Section 27-13.6 - WELDER QUALIFICATION TESTS

1. QUALIFICATION TEST FOR STRUCTURAL WELDERS

The welder qualification test for manual and semi-automatic welding shall be one of the following:

- 1.1 Groove weld test for plate of unlimited thickness.
- 1.2 Groove weld test for butt joints on pipe or square or rectangular tubing of unlimited thickness.
- 1.3 Groove weld test for T-, K-, or Y-connections on pipe or tubing of unlimited thickness.

2. QUALIFICATION TEST FOR SHEET STEEL WELDERS (See Figure 27-13.09.7)

The welder qualification test for Sheet Steel welding shall be a fillet welded T-joint test (sheet to supporting member).

3. QUALIFICATION TEST FOR WELDING OPERATOR (See Figure 27-13.09.8)

The welding operator qualification test shall be a groove weld test on plate.

4. QUALIFICATION TEST FOR REINFORCING STEEL WELDERS (See Figure 27-13.09.9)

The welder qualification test for reinforcing steel welders shall be a flare bevel groove indirect butt joint.

5. QUALIFICATION TEST FOR SEISMIC RESTRICTED ACCESS WELDER

5.1 General

This test is used to qualify welders for flat position groove welding. Backgouging is part of this test when steel backing is used and required to be removed. It is also used to qualify welders when non-steel backing is used, or when open root groove welds are used.

5.2 Test Plate Configuration

The test plate configurations and dimensions shall be as shown in Figure 27-13.14.1 or Figure 27-13.14.2, and Figure 27-13.14.3 as applicable.

5.3 Test Plate Fabrication

5.3.1 General Requirements

5.3.1.1 Test Plate Assembly

The parts for the test plate assembly may be cut and tack welded together by an individual other than the welder performing the qualifications test, except that the welder being qualified shall attach the required weld tabs.

5.3.1.2 Welding Procedure Specification

The test plate assembly shall be welded in accordance with a WPS using the process for which the welder is being qualified. The combination of variables shall be such that the deposition rate used in the qualification test is equal to or greater than the highest deposition rate that will be used in production.

5.3.2 Additional Requirements for Option A

Option A shall be used to qualify welders to use steel backing.

5.3.2.1 Steel Backing

The steel backing shall be a minimum thickness of ¼ in. (6 mm), and a maximum of ¾ in. (18 mm), and shall be at least 1 in. (25 mm) wide. Backing width should be at 3 in. wide if radiography will be used to evaluate weld. The backing shall be attached to the test plate assembly with tack welds.

5.3.2.2 Groove Weld Detail

The groove weld detail shall use a 3/8 in. (6 mm) root opening, +/- 1/16 in. (1.5 mm). The included angle shall be 30 degrees, +/- 5 degrees.

5.3.3 Option A Limitations

Welders qualified in accordance to Option A shall be permitted to weld on any joint that uses steel backing. Separate qualification shall be required if the type of backing is changed (e.g., a change from steel to ceramic, or from steel backing to open root joints, etc.).

5.3.4 Additional Requirements for Option B

Option B shall be used to qualify welders for the use of other than steel backing, including the use of ceramic or copper backing, or open root welding.

5.3.5 Backing Removal

After the groove weld has been completed, the non-steel backing (if used) shall be removed by the welder being qualified.

5.3.6 Backgouging and Backwelding.

Removal shall be done in the overhead position. The root of the weld shall be backgouged to sound metal. The backgouged cavity shall be backwelded. The backwelding shall be performed in the overhead position. The welding process for the overhead welding need not be the same as that used for the flat position welding.

5.3.7 Option B Limitations

Welders qualified in accordance to Option B shall be qualified to use the specific backing type used during the test. Root openings shall be no greater than that used in the welder qualification test. Separate qualifications shall be required if the type of backing is changed (e.g., a change from copper to ceramic, or copper to steel, etc.).

5.4 Specimen Testing

5.4.1 Visual Inspection

After removal of the web plate, column plate and attachment plate, the weldment shall be visually inspected.

5.4.2 Additional Testing

The test plate shall be subject to one of the following tests, at the option of the WABO Examiner:

- (1) Bend tests (See Section 27-13.10.1)
- (2) RT inspection (See Section 27-13.10.4)

5.4.2.1 Bend Tests

5.4.2.1.1 Specimen Locations

The flat test plate shall be cut to prepare four transverse side-bend tests, with each test sample 3/8 inch (10 mm) thick. Two side-bend specimens shall be from the region that was under the 1 inch (25 mm) web plate. Two side bends shall be taken from within 1/4 inch (6 mm) of the ends of the welds. The side of the specimen nearest to the end of the weld shall be clearly marked.

5.4.2.1.2 Specimen Testing Procedure

For the two specimens taken from the ends of the weld, the specimens shall be bent so that the side of the bend specimen that was nearest to the end of the weld becomes the convex side of the bend specimen (e.g., sees the greatest tension).

6. RETEST

In case a welder or welding operator fails to meet the requirements of one or more test welds, a retest may be allowed under the following conditions:

- 6.1 An immediate retest within seven (7) days of notification of failure. The retest shall consist of two test welds of each type in each position on which the welder or welding operator failed.
- 6.2 A subsequent retest may be made provided the welder or welding operator submits documented proof of eight (8) hours minimum further training or practice, in which case a single retest weld of each type and position failed shall be made.

Section 27-13.7 - QUALIFICATION TESTS REQUIRED AND LIMITATIONS

1. General Notes

Field qualification qualifies for shop, but shop qualification does not qualify for field.

Qualified thickness range and positions are shown on Tables 27-13-A through H. The limitations of these certifications are shown on Table 27-13-I.

A welding operator qualified with an approved electrode and shielding medium combination shall be considered qualified to weld with any other approved electrode and shielding medium combination for the process used in the procedure qualification test.

For structural and reinforced steel qualifications, vertical position welding progression shall be upwards.

For each weld process (SMAW, GMAW, FCAW, GTAW, SAW) for which certification is required, test plates or pipe shall be welded using any of the structural steels listed in Table 27-13-J using the electrodes, positions and plate or pipe thicknesses in Tables 27-13-A through E.

For sheet steel welder qualifications, T-joint test plates shall be welded using one of the sheet steels listed in Table 27-13-K using electrodes and positions shown in Tables 27-13-F and 27-13-G. For SMAW, GMAW, and FCAW, Sheet Steel qualification test qualifies welder for both galvanized and uncoated steel. For GTAW, the Sheet Steel Qualification test qualifies the welder for uncoated steel only.

For reinforcing steel welder qualifications No. 4 ASTM A706 bars shall be welded to any of the structural steels listed in Table 27-13-J with the electrodes and in the positions shown on Table 27-13-H. Two (2) test assemblies are required.

The welder shall be certified for the welding process and method used in qualification tests only (SMAW, GMAW, GTAW, FCAW, and SAW). Certifications for all others, including short circuiting ("Short Arc") GMAW, are not covered by this Standard.

Welder shall be qualified to weld all filler metals of the same designation and lower strength than that used in the test (F4 and lower for SMAW process). See Table 27-13-L.

Upgrading from shop to field certifications do not need to be administered by the same examiner or the same WABO testing agency.

SECTION 27-13.8 - VISUAL INSPECTION CRITERIA FOR ACCEPTANCE

All welds shall be visually inspected. The root pass shall be visually inspected and approved by the WABO Approved Welder Examiner prior to continuation. Final visual inspection of welds may begin immediately after the completed welds have cooled to ambient temperature.

1. PLATE AND REINFORCING STEEL WELDS

A weld shall be acceptable by visual inspection if it shows the following:

- 1.1 The weld has no cracks or arc strikes outside the weld area.
- 1.2 Thorough fusion exists between adjacent layers of weld metal and between weld metal and base metal.
- 1.3 All craters are filled to the full cross section of the weld.
- 1.4 Weld profiles are in accordance with Section 27-13.8.4.
- 1.5 Undercut is no more than 1/32 " deep, nor exceeds ten percent (10%) of the test weld length.
- 1.6 The piping porosity does not exceed one pore.
- 1.7 Welds are started and terminated at the end of a joint in a manner that will insure sound welds.

2. PIPE AND TUBING WELDS

A pipe weld shall be acceptable by visual inspection if it shows the following:

- 2.1 The weld has no cracks or arc strikes outside the weld area.
- 2.2 All craters are filled to the full cross section of the weld.
- 2.3 The face of the weld is at least flush with the outside surface of the pipe, and the weld is merged smoothly with the base metal. Undercut shall not exceed 1/32" and weld reinforcement shall not exceed the following:

Pipe Wall Thickness (Inches)	Reinforcement, Maximum (Inches)
3/8 or less	3/32
3/8 to 3/4 incl.	1/8
Over 3/4	3/16

- 2.4 There is no evidence of cracks, incomplete fusion, or inadequate joint penetration in the root. A concave root surface is permitted, within the limits of Section 27-13.8.2.2.5, below, provided the total weld thickness is equal to or greater than that of the base metal.
- 2.5 The maximum root surface concavity is 1/16 ", and the maximum melt-through is 1/8 inch.

3. SHEET STEEL FILLET WELDS

A fillet weld shall be acceptable by visual inspection if it is reasonably uniform in appearance and is free of overlap, cracks, and excessive undercut.

4. ACCEPTABLE AND UNACCEPTABLE WELD PROFILES

Groove welds shall preferably be made with slight or minimum reinforcement. The reinforcement shall not exceed 1/8 inch in height and shall have gradual transition to the plane of the base metal surface (see Figure 27-13.10.1). Welds shall be free of the discontinuities shown for butt joints (See Figure 27-13.10.2).

Section 27-13.9 - TEST SPECIMENS, ROOT-, FACE-, OR SIDE-BEND

1. TYPE AND NUMBER

The type and number of test specimens that must be mechanically tested to qualify a welder when radiographic testing is not used are shown in Figures 27-13-11.1 through 11.8.

Section 27-13.10 – METHODS OF TESTING SPECIMENS

1. ROOT-, FACE-, OR SIDE-BEND TEST AND EVALUATION

The entire length of the groove weld shall be examined visually prior to cutting specimens.

Each specimen shall be bent in a jig having the contour shown in Figure 27-13-12.1 and otherwise substantially in accordance with that Figure. Any convenient means may be used to move the plunger member with relation to the die member.

The specimen shall be placed on the die member of the jig with the weld at midspan.

Root-bend specimens shall be placed with the root of the weld directed toward the die member.

Face-bend specimens shall be placed with the face of the weld directed toward the die member.

Side-bend specimens shall be placed with that side showing the greater discontinuity, if any, directed toward the die member.

The plunger member shall force the specimen into the die member until the specimen becomes U-shaped. The weld and heat-affected zones shall be centered and completely within the bent portion of the specimen after testing.

The convex surface of the bend test specimen shall be visually examined for surface discontinuities. For acceptance, the surface shall contain no discontinuities exceeding the following dimensions:

1.1 1/8 inch - measured in any direction on the surface

- 1.2 3/8 inch - the sum of the greatest dimensions of all discontinuities exceeding 1/32 inch, but less than or equal to 1/8 inch
- 1.3 1/4 inch - the maximum corner crack, except when that corner crack resulted from visible slag inclusion or other fusion type discontinuities, then the 1/8 inch maximum shall apply. Specimens with corner cracks exceeding 1/4 inch with no evidence of slag inclusions or other fusion type discontinuities shall be disregarded, and a replacement test specimen from the original weldment shall be tested

2. SHEET STEEL FILLET WELD BREAK TEST AND EVALUATION

The entire length of the fillet weld (see Figure 27-13-12.2) shall be examined visually and then the 5 inch long specimen shall be loaded in such a way that the root of the weld is in tension. The load shall be steadily increased or repeated until the specimen fractures, or bends flat upon itself.

The specimen shall pass the test if it bends flat upon itself or, if the fillet weld fractures, the fractured surface shows complete fusion to the root of the joint.

3. REINFORCING STEEL WELD TEST AND EVALUATION

The entire length of the flare bevel groove welds shall be visually examined. Then each test assembly shall be mechanically cut at two locations to provide two transverse cross sections of each weld assembly.

A macrotech test shall be performed by polishing and etching cross sections with a suitable solution to give a clear definition of the weld. The etched cross section shall show the minimum designated effective weld size for the flare groove test assemblies. (See Figure 27-13.09.9)

4. RADIOGRAPHIC TESTING

Radiographic examination of the welder or welding operator test plate may be made in lieu of a bend test.

If radiographic testing is used in lieu of the prescribed bend tests, the weld reinforcement need not be ground or otherwise smoothed for inspection unless its surface irregularities or juncture with the base metal would cause objectionable weld discontinuities to be obscured in the radiograph. If the backing is removed for radiography, the root shall be ground flush with the base metal.

Exclude 1-1/4 inch at each end of the weld from evaluation in the plate test for welder qualification and exclude three (3) inches at each end of the length of the test plate for welding operator qualification.

Welded test pipe shall be examined for a minimum of one-half of the weld perimeter selected to include a sample of all positions welded. (For example, a test pipe or tube welded in the 5G, 6G or 6GR position shall be radiographed from the top center line to the bottom center line on either side.)

The radiographic procedure and technique shall be in accordance with the current requirements of ANSI/AWS D1.1.

For acceptable qualification by the radiograph, the weld shall have no cracks and shall conform to the following:

- 4.1 The greatest dimension of any porosity or fusion-type discontinuity that is 1/16 inch or larger in greatest dimension shall not exceed size (B), indicated in Figure 27-13-13.1 for the effective throat or weld size involved. The distance from any porosity or fusion-type discontinuity described above to another such discontinuity shall not be less than the minimum clearance allowed (C) indicated in Figure 27-13-13.1 for the size of discontinuity under examination.
- 4.2 Discontinuities having a greatest dimension of less than 1/16 inch shall be unacceptable if the sum of their greatest dimension exceeds 3/8 inch in any linear inch of weld.

SECTION 27-13.11 – TECHNICAL INQUIRIES

All inquiries must be submitted in writing to:
Welding Performance Standard Technical Advisory Task Force
WABO
PO Box 7310
Olympia WA 98507-7310

All inquiries must contain the name, address, and affiliation of the inquirer and they must provide enough information for the Task Force members to fully understand the point of concern in the inquiry. Where that point is not clearly defined, the inquiry will be returned for clarification. Inquiries should be typewritten – electronic mail is acceptable.

Each inquiry should be limited to a single point unless the inquiry involves two or more interrelated concerns. And, the inquiry should be concise, yet complete, to enable the Task Force members to quickly and fully understand the point of inquiry. Sketches should be used when appropriate and all paragraphs, figures and tables, which relate to the inquiry, must be provided.

Telephone inquiries to WABO concerning the WABO Standard 27-13 should be limited to questions of a general nature or to matters directly related to administration of the WABO Welder Certification Program. WABO Board of Directors policy requires that all program support personnel respond to a telephone request for a technical inquiry with information that such an inquiry can only be obtained through a written request. Welder program support personnel can not provide consulting services.

SECTION 27-13.12 – CHALLENGES AND APPEALS

An agency contact of a registered agency or certified welder in the WABO Welder Qualifying Agency Registration and Welder Certification Program may challenge or appeal, in writing, upon any ground, the result of an agency survey/audit; individual application review, examination or interview; or, any program-related disciplinary action.

A challenge shall be submitted in writing to and reviewed by the WABO executive director, or designee, pursuant to the procedures adopted to implement this policy.

If the challenge is rejected by the executive director, or their designee, the challenger may then appeal in writing to the WABO Certification and Registration Committee.

If the challenge is rejected by the Certification and Registration Committee, the challenger may then appeal in writing to the WABO Executive Board.

If the WABO Executive Board denies the appeal, the challenger's final right of appeal shall be to a Hearing Officer appointed by the WABO Executive Board, pursuant to the procedures adopted to implement this policy.

SECTION 27.13.13 – SUSPENSION AND WITHDRAWALS

The registration of a specific agency and/or the certification of its personnel may be suspended or withdrawn, pursuant to the procedures adopted to implement this policy.

Failure to abide by any terms of a suspension may result in registration for the agency and/or certification of its personnel being withdrawn.

A registration or certification need not have been suspended before being withdrawn.

WABO executive director shall advise the agency contact person of his/her right to challenge or appeal a suspension or withdrawal action.

LIST OF FIGURES

QUALIFICATION TEST POSITIONS – GROOVE

Figure		Page
27-13.01	Test Position 1G (Plates)	21
27.13.01	Test Position 2G (Plates)	21
27.13.01	Test Position 3G (Plates)	21
27.13.01	Test Position 4G (Plates)	21

QUALIFICATION TEST POSITIONS – FILLET

27.13.02	Test Position 3F (Plates)	22
27.13.02	Test Position 4F (Plates)	22

QUALIFICATION TEST POSITIONS – PIPE OR TUBING

27.13.03	Test Position 2G (Pipe or Tubing)	23
27.13.03	Test Position 5G (Pipe or Tubing)	23
27.13.04	Test Position 6G (Pipe)	24
27.13.04	Test Position 6GR (Pipe)	24
27.13.05	Parts of a Tubular Connection	25

(Figures 27-13.6 through 27-13.7 intentionally left blank)

QUALIFICATION TEST POSITIONS – REINFORCING STEEL

27.13.08	Test Position - Vertical	26
27.13.08	Test Position - Overhead	26

QUALIFICATION TEST CONFIGURATIONS

27.13.09.1	Test Plate – Unlimited Thickness	27
27.13.09.2	Test Plate – Limited Thickness (GMAW and GTAW only)	28
27.13.09.3	Test Plate – Optional Unlimited Thickness	29
27.13.09.4	Test Plate – Optional Limited Thickness	29
27.13.09.5	Pipe – Butt Joint (Without Backing)	30
27.13.09.5	Pipe – Butt Joint (With Backing)	30

LIST OF FIGURES

Figure	Page
QUALIFICATION TEST CONFIGURATIONS (continued)	
27.13.09.6 Test Joint for T-, K-, and Y-Connections on Pipe or Tubing	31
27.13.09.7 Sheet Steel Fillet Weld Test Assembly.....	32
27.13.09.8 Welding Operator – Unlimited Thickness	33
27.13.09.9 Reinforcing Steel Test Assembly.....	34
27.13.10.1 Acceptable Groove Weld Profile (Plate)	35
27.13.10.2 Unacceptable Groove Weld Profiles (Plate).....	35
TEST SPECIMENS, ROOT-, FACE-, OR SIDE BEND	
27.13.11.1 Groove Test Plate – Unlimited Thickness	36
27.13.11.2 Groove Test Plate – Limited Thickness (GMAW and GTAW only)	37
27.13.11.3 Pipe Test – 2G Position.....	37
27.13.11.4 Pipe Test – 5G and 6G Position.....	38
27.13.11.5 Pipe Test – 6GR Position.....	38
27.13.11.6 Welding Operator Test Plate – Unlimited Thickness	39
27.13.11.7 Side-Bend.....	40
27.13.11.8 Face and Root-Bend.....	40
27.13.12.1 Guided Bend Test Jig Specifications	41
27.13.12.2 Fillet Break Specimen.....	42
27.13.13.1 Radiographic Weld Quality Requirements for Discontinuities	43
QUALIFICATION TEST CONFIGURATIONS – SEISMIC	
27.13.14.1 Test Plate Configuration for Option A.....	44
27.13.14.2 Test Plate Configuration for Option B.....	45
27.13.14.3 Test Plate Configuration Illustration.....	45

QUALIFICATION TEST POSITIONS – GROOVE

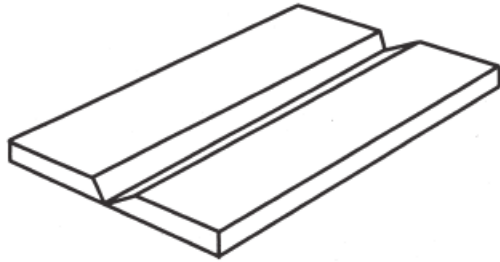

FLAT
TEST POSITION 1G

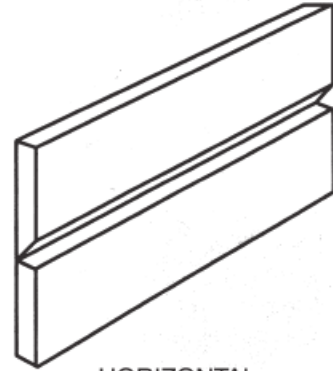

HORIZONTAL
TEST POSITION 2G



VERTICAL
TEST POSITION 3G

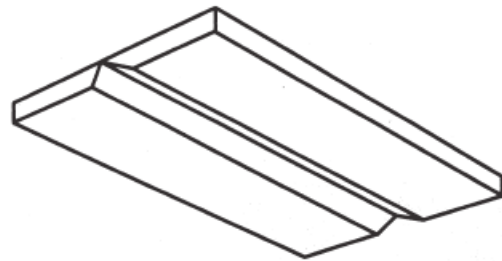

OVERHEAD
TEST POSITION 4G

FIGURE 27-13.01

QUALIFICATION TEST POSITIONS – FILLET

AXIS OF WELD VERTICAL

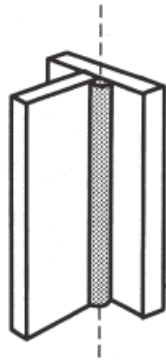

VERTICAL
TEST POSITION 3F

AXIS OF WELD
HORIZONTAL

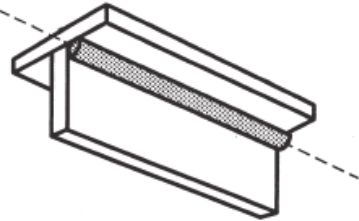

NOTE: ONE PLATE MUST BE HORIZONTAL

OVERHEAD
TEST POSITION 4F

FIGURE 27-13.02

QUALIFICATION TEST POSITIONS – PIPE

TEST POSITION 2G

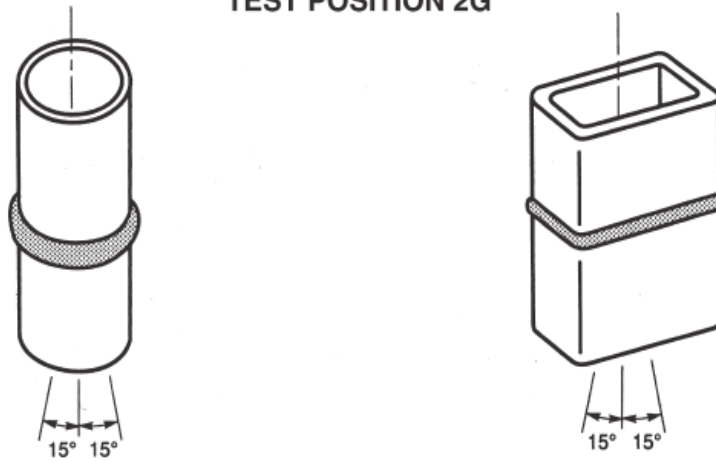

THE TEST PIPE SHALL BE PLACED WITH ITS AXIS WITHIN $\pm 15^\circ$ OF THE VERTICAL AND THE WELDING GROOVE HORIZONTAL. THE PIPE IS NOT ROTATED DURING WELDING.

TEST POSITION 5G

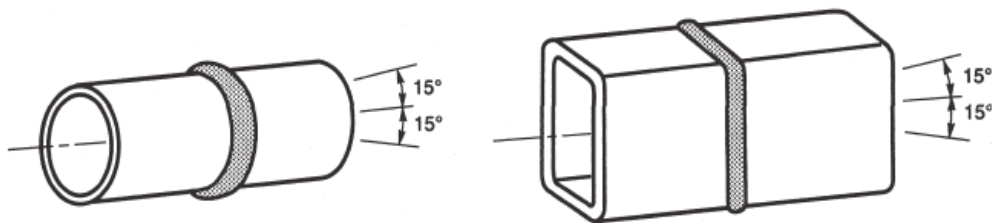

THE TEST PIPE SHALL BE PLACED WITH ITS AXIS WITHIN $\pm 15^\circ$ OF THE HORIZONTAL AND THE GROOVE VERTICAL. THE PIPE IS NOT ROTATED DURING WELDING.

FIGURE 27-13.03

QUALIFICATION TEST POSITIONS – PIPE

TEST POSITION 6G

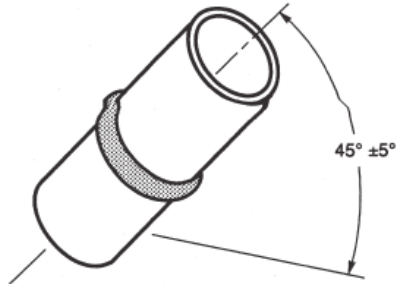

THE TEST PIPE SHALL BE INCLINED AT $45^\circ, \pm 5^\circ$, WITH THE HORIZONTAL.
THE PIPE IS NOT ROTATED DURING WELDING.

TEST POSITION 6GR (T-, K-, AND Y-CONNECTIONS)

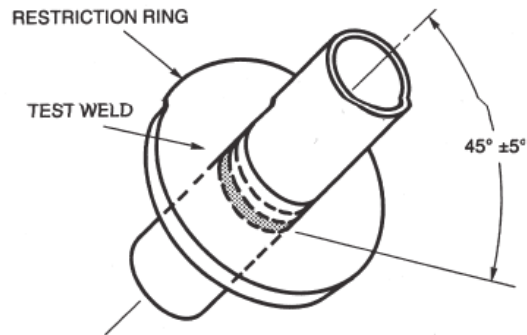

THE TEST PIPE SHALL BE INCLINED AT $45^\circ, \pm 5^\circ$, WITH THE HORIZONTAL.
THE PIPE OR TUBE IS NOT ROTATED DURING WELDING.

FIGURE 27-13.04

PARTS OF A TUBULAR CONNECTION

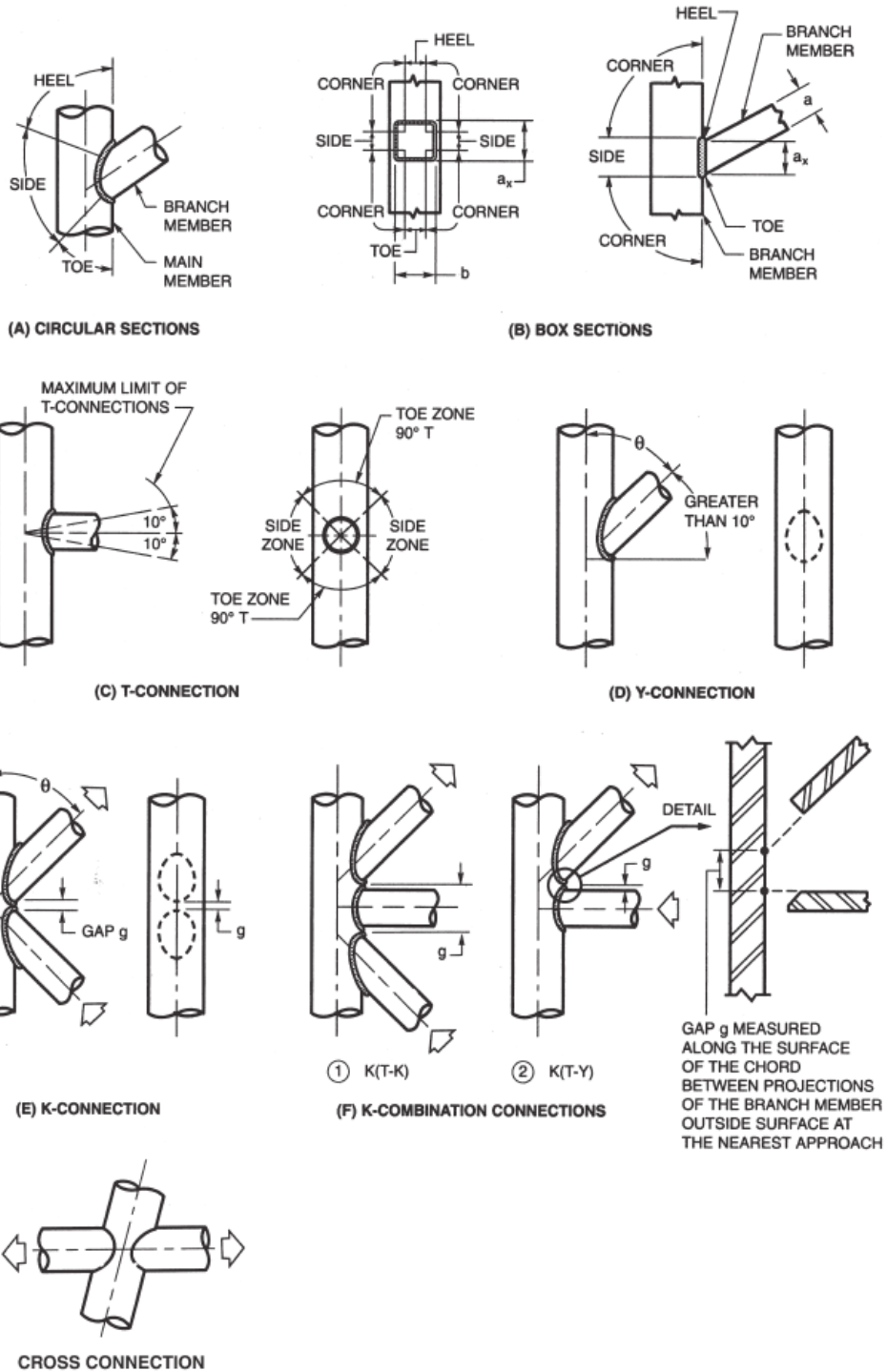
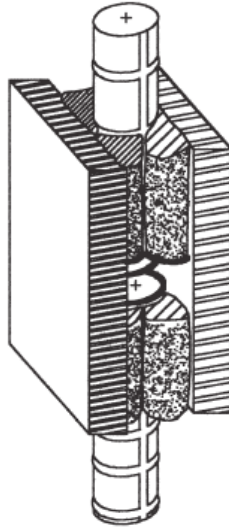
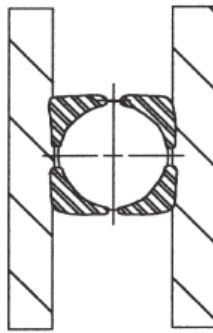

FIGURE 27-13.05

QUALIFICATION TEST POSITIONS – REINFORCING STEEL



TEST POSITION; VERTICAL
(AXIS OF WELD VERTICAL)



TEST POSITION; OVERHEAD
(AXIS OF WELD HORIZONTAL)

FIGURE 27-13.08

TEST PLATE FOR WELDER QUALIFICATION
UNLIMITED THICKNESS

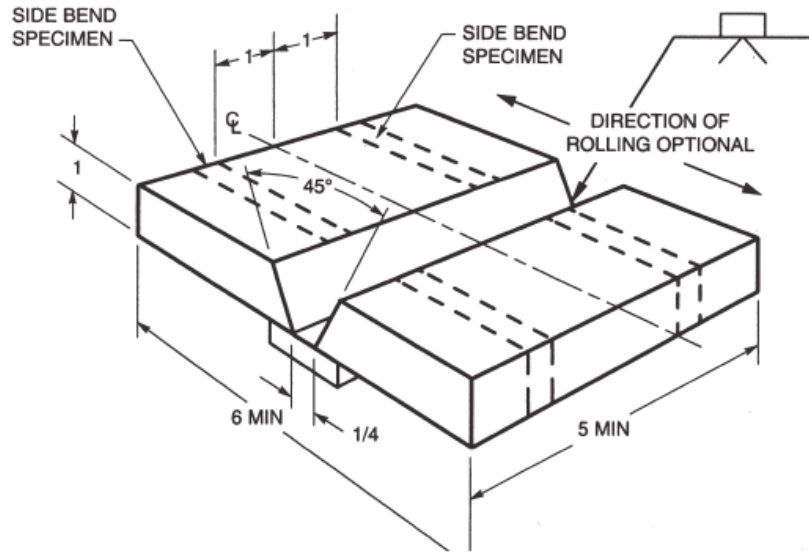

Note: When radiography is used for testing, no tack welds shall be in the test area.

The joint detail shall be as follows:

1 inch plate, single-V-groove, 45 degree included angle, 1/4 inch maximum root opening with backing. Backing must be 1/4 inch to 3/8 inch by 1 inch.* Minimum length of welding groove shall be 5 inch.

When radiography is used for qualification, backing must be at least 3/8 inch by 3 inch, if backing is not removed prior to test.

FIGURE 27-13.09.1

TEST PLATE FOR WELDER QUALIFICATION
LIMITED THICKNESS (GMAW AND GTAW ONLY)

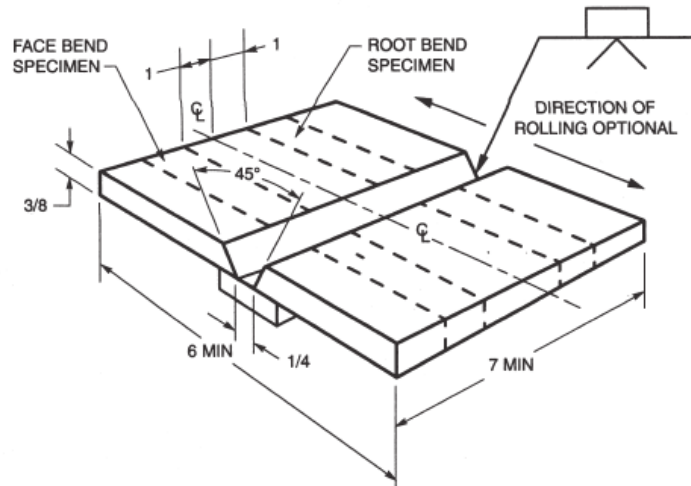

Note: When radiography is used for testing, no tack welds shall be in the test area.

The joint detail shall be as follows:

Plate of designated thickness, single-V-groove, 45 degree angle, 1/4 inch maximum root opening with backing. Backing must be 1/4 inch to 3/8 inch by 1 inch.* Minimum length of welding groove shall be 7 inch.

*When radiography is used for qualification attempts, backing must be at least 3/8 inch by 3 inch (1/4 inch by 3 inch for GTAW), if backing is not removed prior to test.

FIGURE 27-13.09.2

**OPTIONAL TEST PLATE FOR WELDER QUALIFICATIONS
HORIZONTAL POSITION**

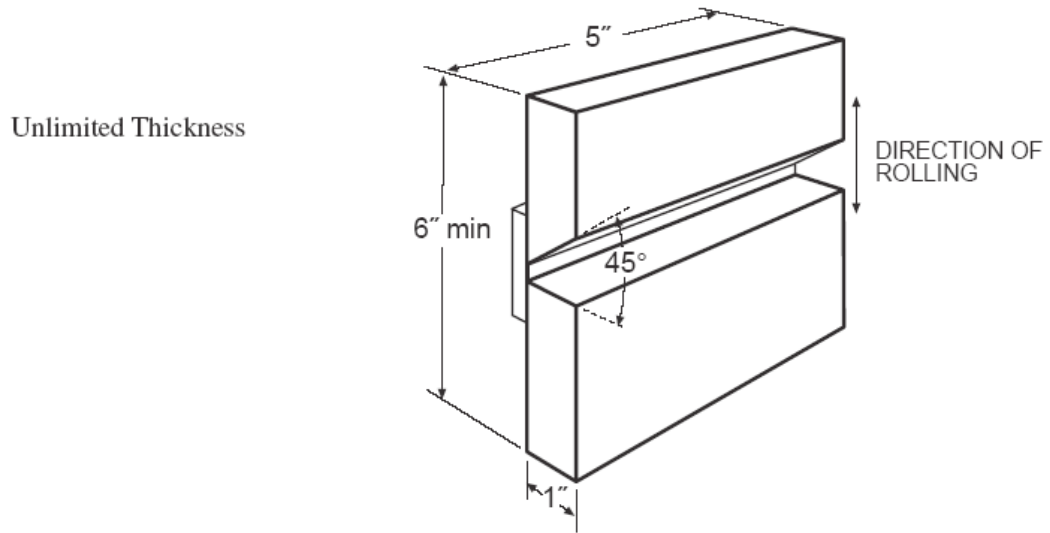
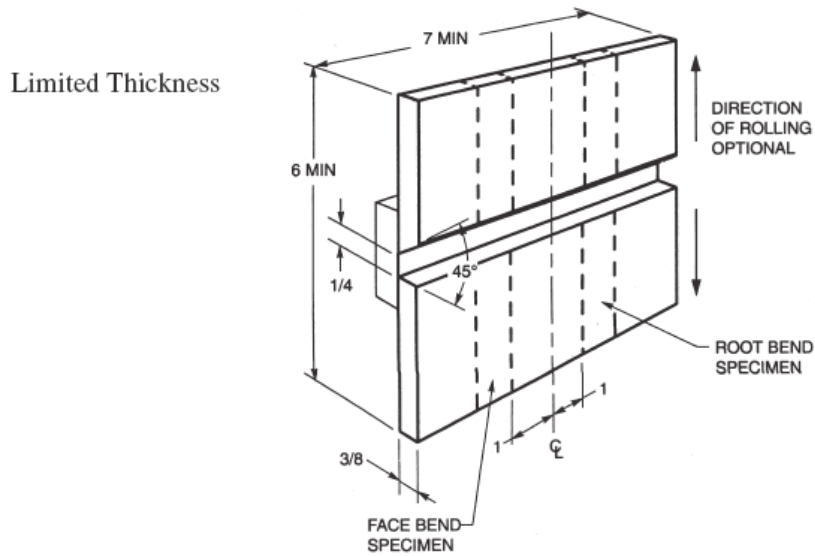

FIGURE 27-13.09.3



Note: When radiography is used for testing, no tack welds shall be in the test area.

For horizontal position qualification, the joint detail may be as follows: single-bevel groove, 45 degree angle, 1/4 inch maximum root opening with backing.

FIGURE 27-13.09.4

**PIPE BUTT JOINT
Welder Qualification - Without Backing**

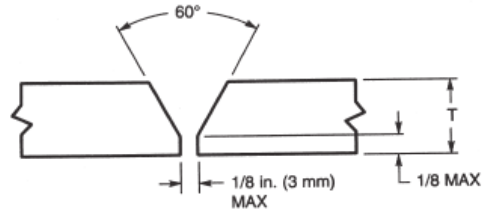

The joint detail shall be as follows:

Pipe diameter-wall thickness as designated, single-V-groove, 60 degree included angle, 1/8 inch maximum root face and root opening without backing strip.

**PIPE BUTT JOINT
Welder Qualification - With Backing**

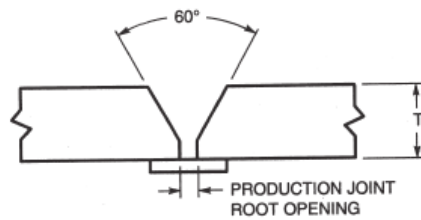

Note: Qualification with backing strip or ring does not qualify for welding without backing strip.

FIGURE 27-13.09.5

TEST JOINT FOR T-, K-, AND Y-CONNECTIONS ON PIPE OR TUBING

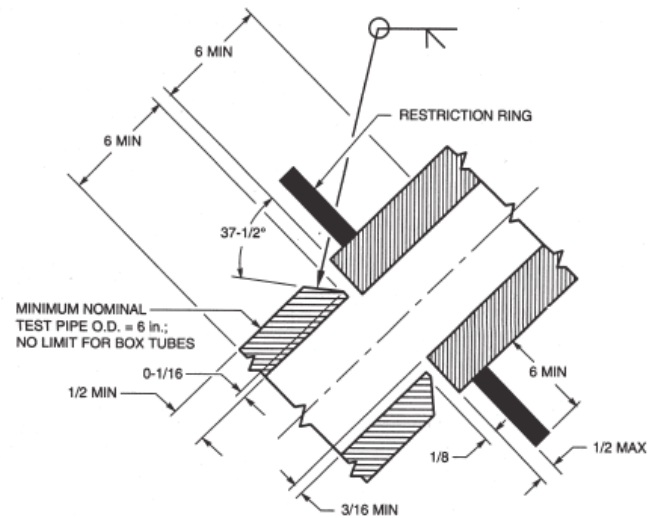

The joint detail shall be as follows: Single-bevel, 37 1/2 degree included angle with bevel on pipe or tube at least 1/2 inch thick; the square edge of the pipe or tube shall be at least 3/16 inch thicker than the beveled pipe thickness; 1/16 inch maximum root face and 1/8 inch root opening. A restriction ring shall be placed on the thicker material, within 1/2 inch of the joint and shall extend at least 6 inches beyond the surface of the pipe or tube.

FIGURE 27-13.09.6

**QUALIFICATION TEST CONFIGURATION –
SHEET STEEL FILLET WELD TEST ASSEMBLY**

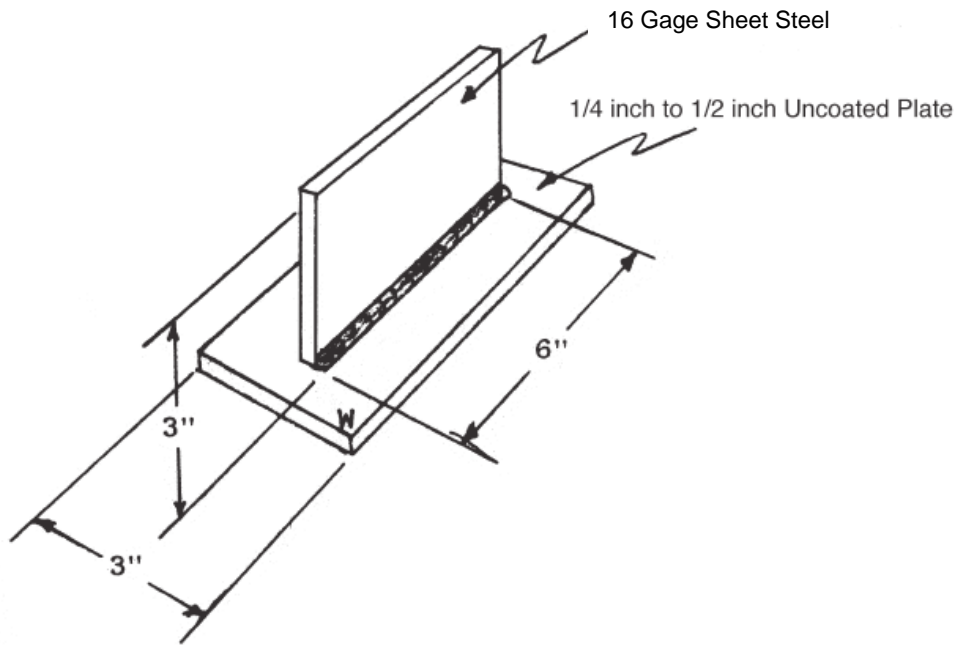
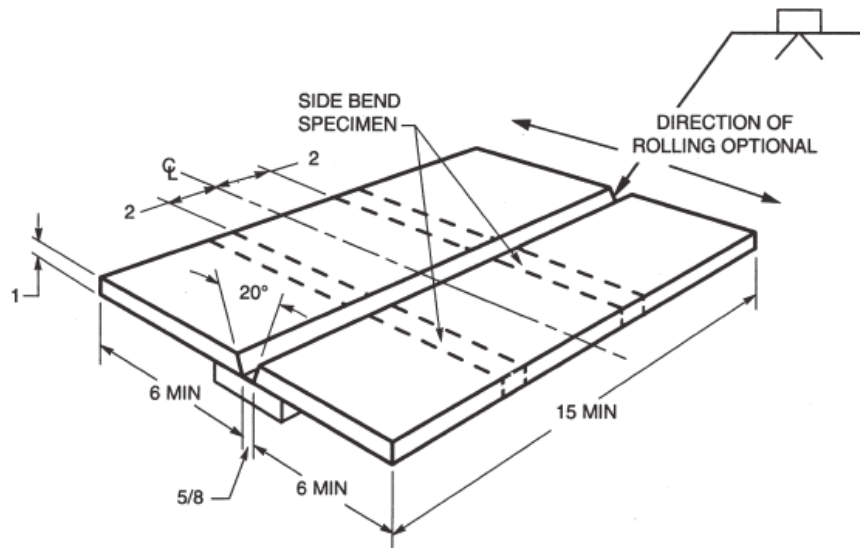

FIGURE 27-13.09.7

QUALIFICATION TEST CONFIGURATION – WELDING OPERATOR – UNLIMITED THICKNESS



The joint detail shall be as follows: 1 inch plate, single-V-groove, 20 degree included angle, 5/8 inch root opening with backing plate. Backing must be at least 3/8 inch by 3 inch if radiography is used for testing without removal of backing. Backing must be at least 3/8 inch by 1 1/2 inch for mechanical testing, or for radiographic testing after the backing is removed. Minimum length of welding groove shall be 15 inches.

FIGURE 27-13.09.8

ACCEPTABLE GROOVE WELD PROFILE – PLATE

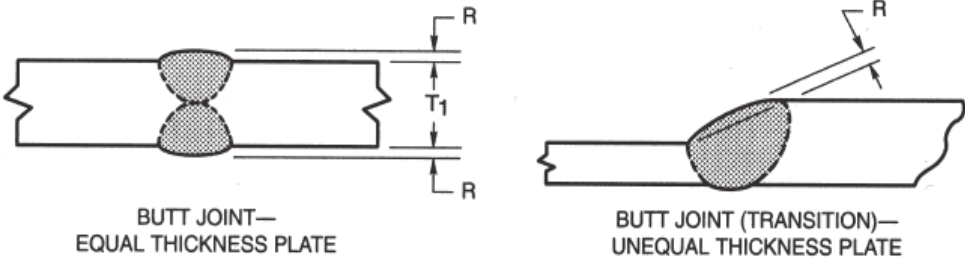

NOTE: REINFORCEMENT R SHALL NOT EXCEED 1/8 in. (3 mm).

FIGURE 27-13.10.1

UNACCEPTABLE GROOVE WELD PROFILES – PLATE

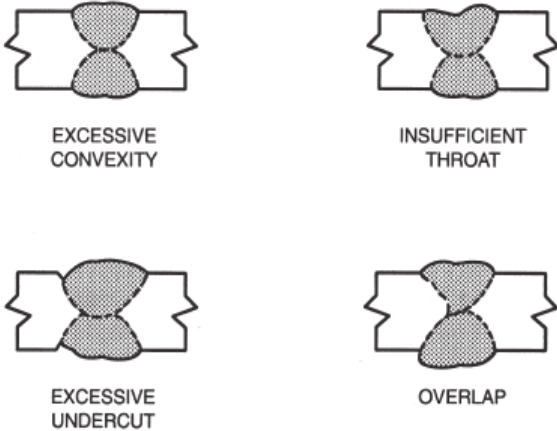

UNACCEPTABLE GROOVE WELD PROFILES IN BUTT JOINTS

FIGURE 27-13.10.2

**GROOVE TEST PLATE –
UNLIMITED THICKNESS**

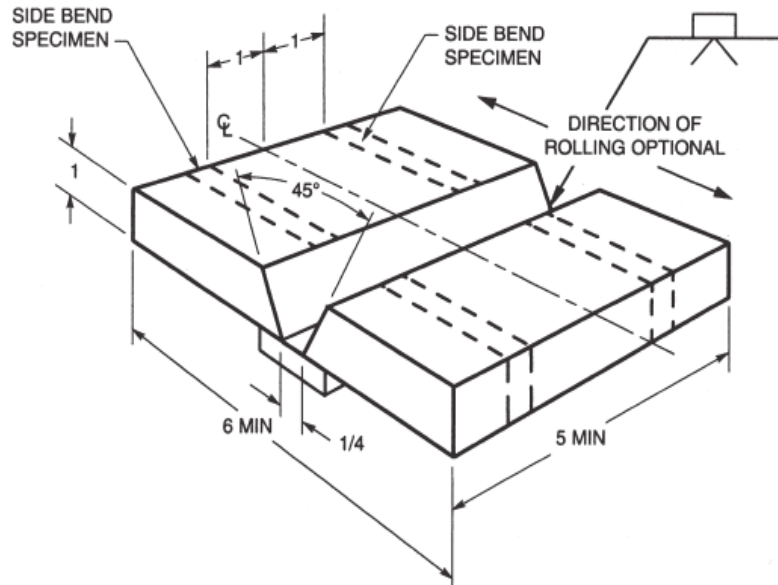
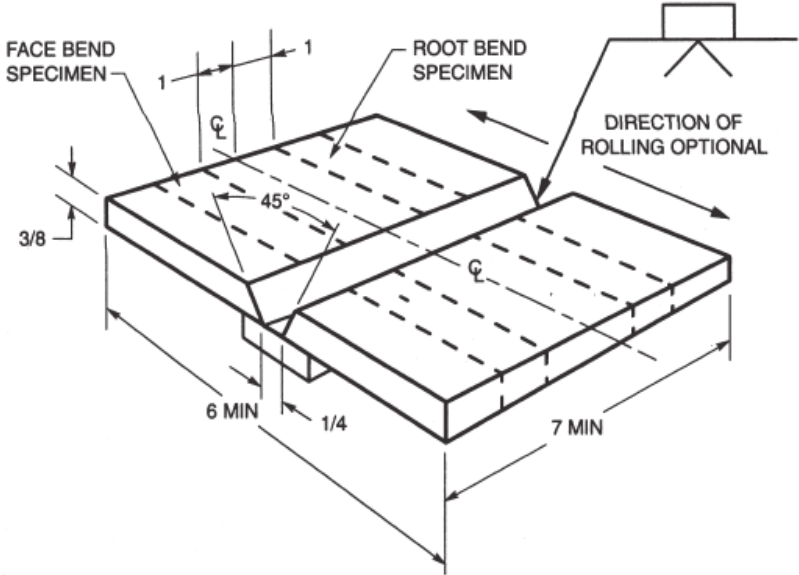

FIGURE 27-13.11.1

**GROOVE TEST PLATE –
LIMITED THICKNESS (FOR GMAW AND GTAW ONLY)**



Note: When radiography is used for testing, no tack welds shall be in the test area.

FIGURE 27-13.11.2

**PIPE TEST
2G POSITION**

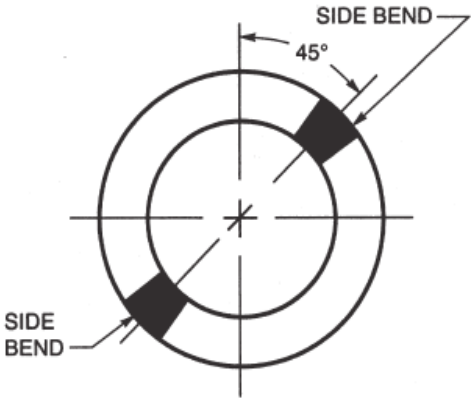

FIGURE 27-13.11.3

PIPE TEST – 5G AND 6G POSITIONS

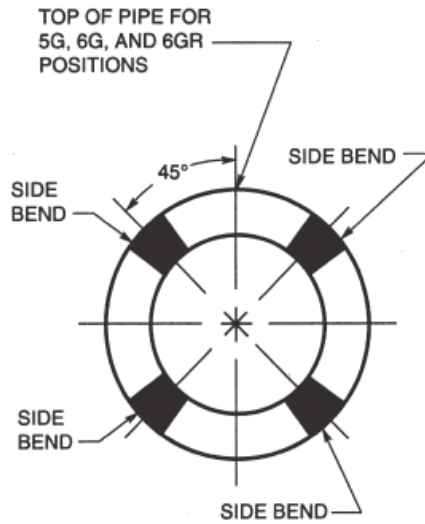
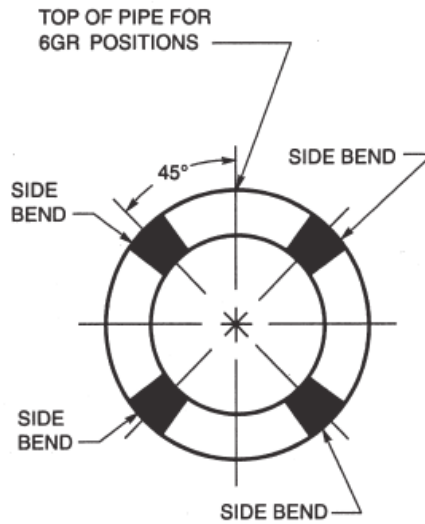

FIGURE 27-13.11.4

PIPE TEST – 6GR POSITION



Specimens for side bends shall be taken as indicated and machined to be standard specimens with parallel sides.

FIGURE 27-13.11.5

WELDING OPERATOR TEST PLATE UNLIMITED THICKNESS

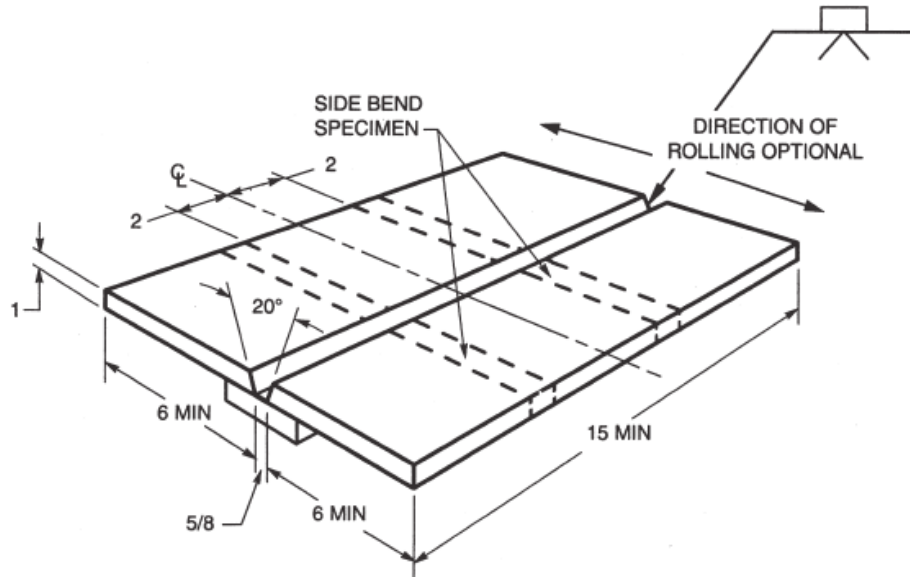

Note: When radiography is used for testing, no tack welds shall be in the test area.

FIGURE 27-13.11.6

SIDE-BEND

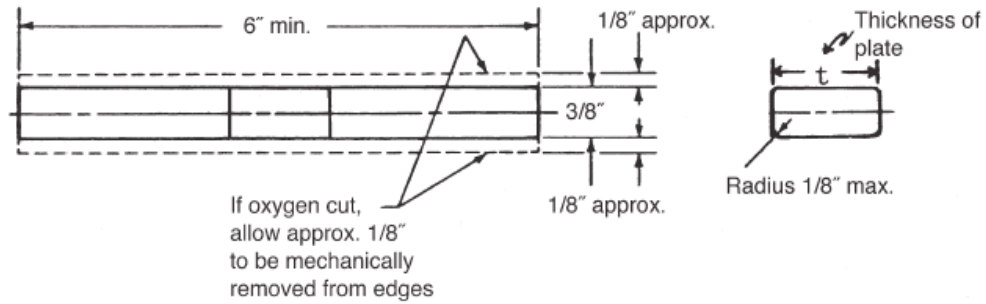
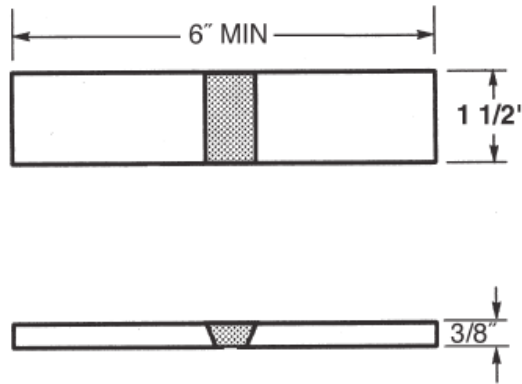

FIGURE 27-13.11.7

FACE AND ROOT-BEND



- Notes: 1. These edges may be oxygen-cut and may or may not be machined.
2. The weld reinforcement and backing, if any, shall be removed flush with the surface of the specimen. If a recessed backing is used, this surface may be machined to a depth not exceeding the depth of the recess to remove the backing; in such cases, the thickness of the finished specimen shall be that specified above. Cut surfaces shall be smooth and parallel.

FIGURE 27-13.11.8

FILLET BREAK SPECIMEN

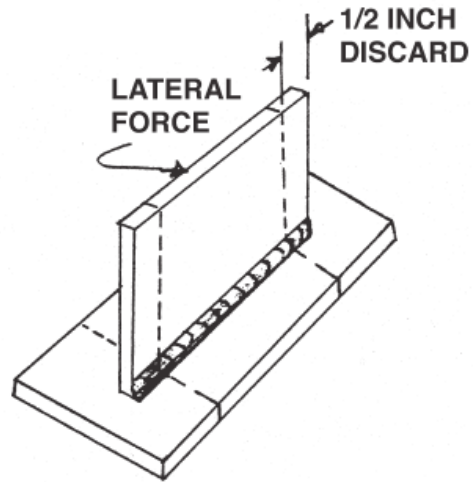

The fillet weld break specimen shall be cut from the test coupon as shown.

FIGURE 27-13.12.2

RADIOGRAPHIC WELD QUALITY REQUIREMENTS FOR DISCONTINUITIES

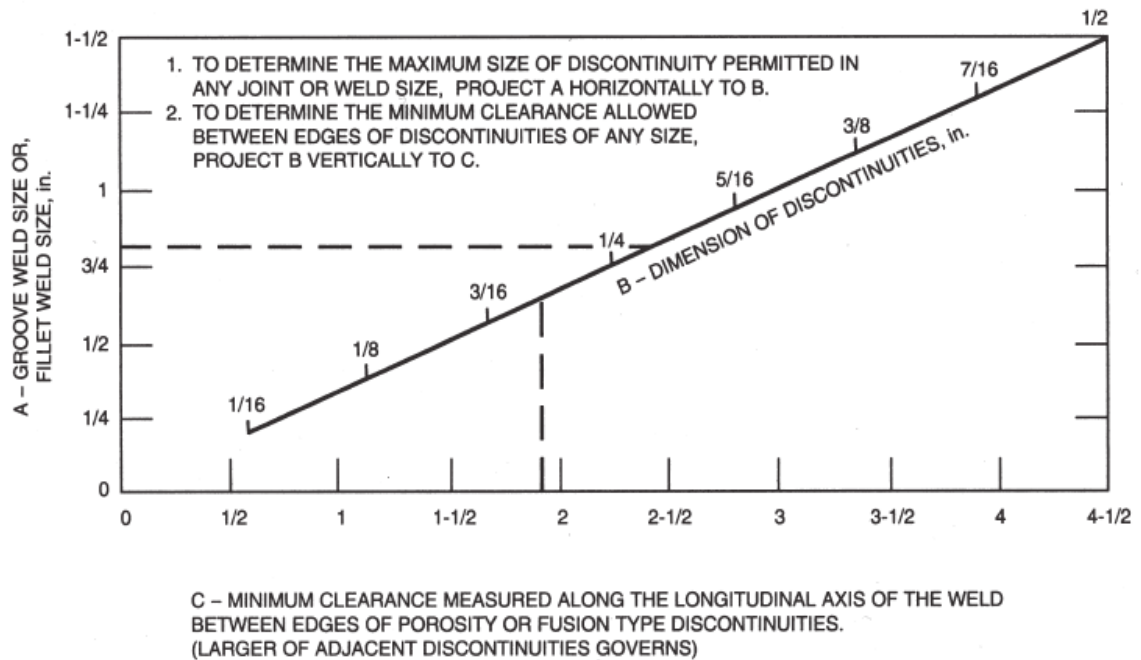

Note: Adjacent discontinuities, spaced less than the minimum spacing required by Figure 27-13-32 shall be measured as one length equal to the sum of the total length of the discontinuities plus the length of the space between them and evaluated as a single discontinuity.

FIGURE 27-13.13.1

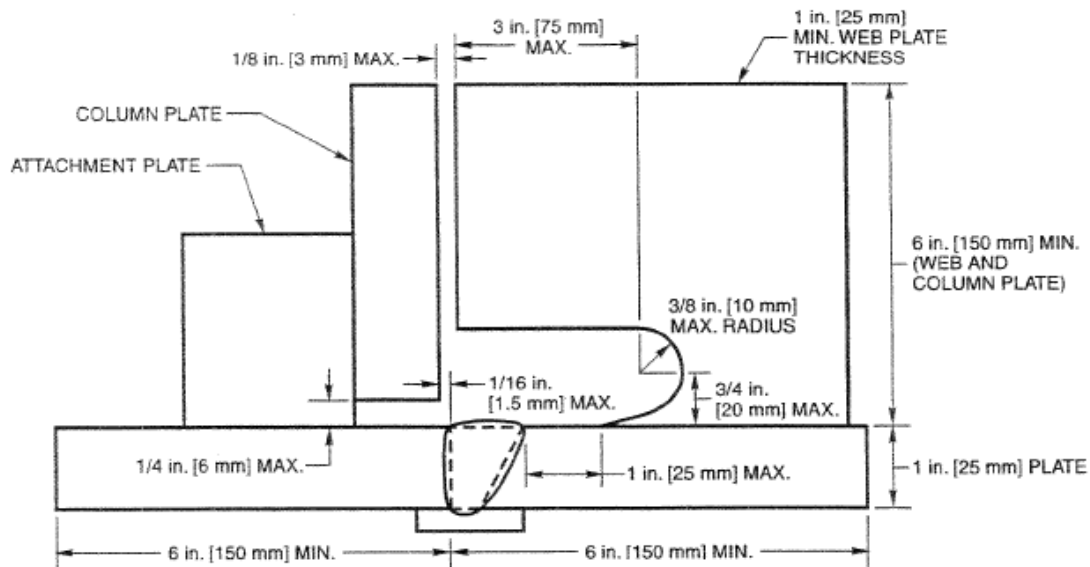

Notes:

1. The weld access hole dimensions are applicable for this test only.
2. Groove dimensions shall be 3/8 in. [10mm] root opening and 30° bevel.
3. Steel backing shall be equal to or greater than 1/4 in. [6mm] but not greater than 3/4 in. [20mm] thick, and shall be a minimum of 1 in. [25mm] wide. The length of the backing shall be 12 in. [300mm], plus run off length, min.
4. The test plates and column plate shall be same length, 12 in. [300mm] min.
5. The attachment plate may be of any size and dimension.
6. The column plate may be any thickness.

FIGURE 27-13.14.1 – TEST PLATE CONFIGURATION FOR OPTION A

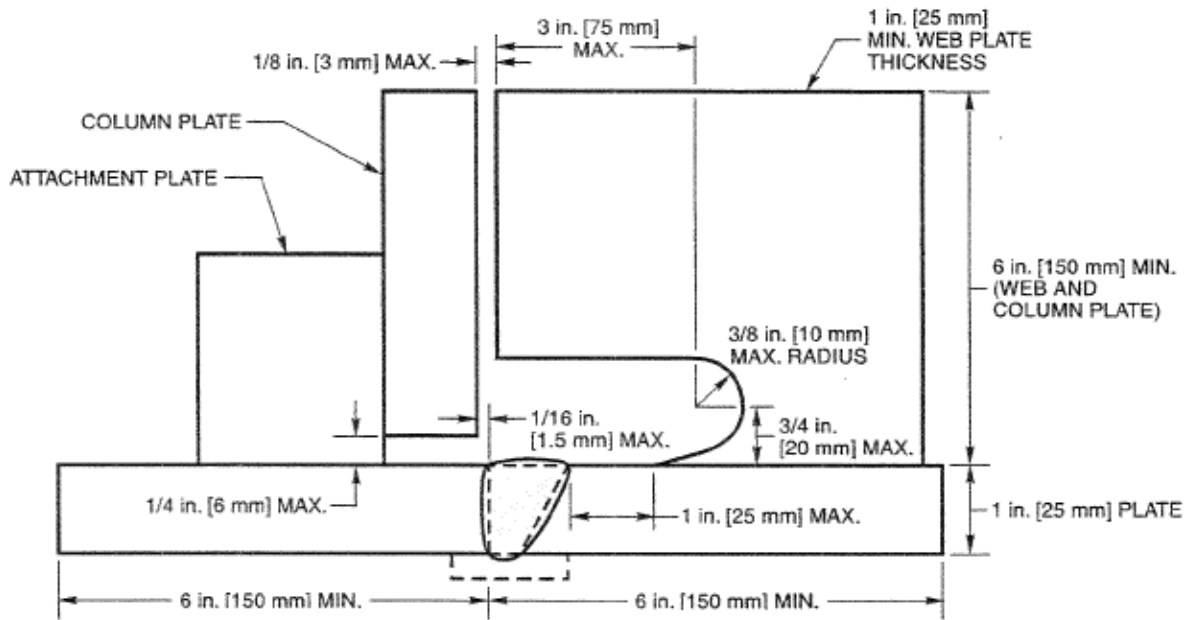

Notes:

1. The weld access hole dimensions are applicable for this test only.
2. Non-steel backing shall be used or shall be open root.
3. Groove shall be 30° bevel. Root opening used for test will be the maximum that weld is qualified for.
4. The test plates and column plate shall be same length, 12 in. [300mm] min.
5. The attachment plate may be of any size and dimension.
6. The column plate may be any thickness.

FIGURE 17-13.14.2 – TEST PLATE CONFIGURATION FOR OPTION B

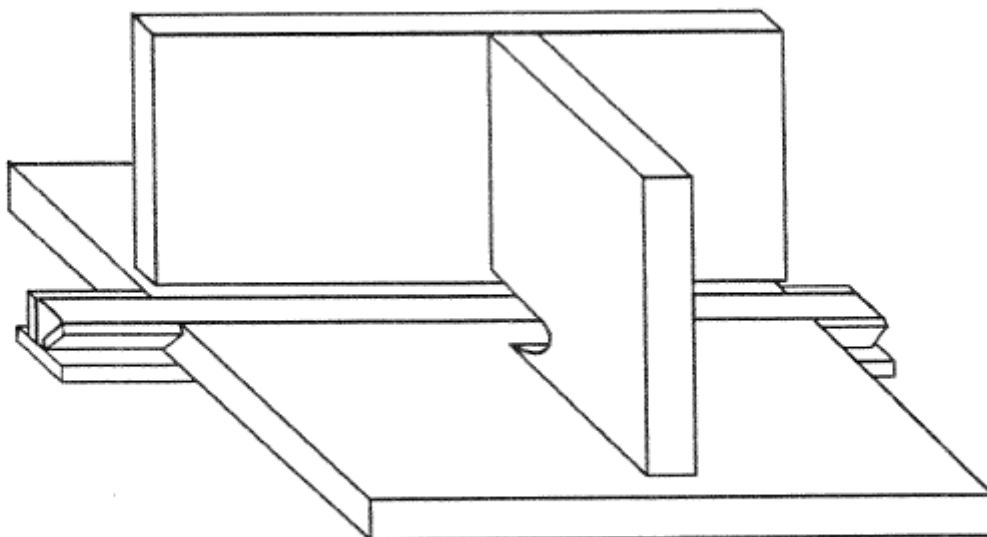

Note:

1. The web location shall be marked on the test plates prior to disassembling the test configuration (see C3.1.4).
2. The web plate shall be centered on the test plate.

FIGURE 17-13.14.3 – TEST PLATE CONFIGURATION ILLUSTRATION

LIST OF TABLES

Table		Page
27-13-A	Specifications for Field Certification Structural Welder - Plate	47
27-13-B	Specifications for Shop Certification Structural Welder - Plate	47
27-13-C	Specifications for Field Certification Structural Welder - Pipe	47
27-13-D	Specifications for Shop Certification Structural Welder - Pipe	48
27-13-E	Specifications for Field & Shop Certification T-, K- and Y- Connections - Pipe or Tubing	48
27-13-F	Specifications for Field Certification Sheet Steel Fillet Weld	49
27-13-G	Specifications for Shop Certification Sheet Steel Fillet Weld	49
27-13-H	Specifications for Shop Certification	49
27-13-I	Limitation of Certificates	50
27-13-J	Matching Filler Metal Requirements	51
27-13-K	Sheet Steel	52
27-13-L	Filler Metal Numbers – SMAW Process	52
27-13-M	Nominal Dimensions of Standard Reinforcing Bars	53
27-13-N	Designations for Welding and Allied Processes (Alphabetically by Process)	54
27-13-O	Designations for Welding and Allied Processes (Alphabetically by Designation)	55
27-13-P	Standard Welding Symbols	56
27-13-Q	Terms and Definitions	59

TABLE 27-13-A
SPECIFICATIONS FOR *FIELD* CERTIFICATION
STRUCTURAL WELDER – PLATE

	USE ELECTRODE WITH AWS DESIGNATION	QUANTITY OF TEST PLATES TO WELD IN POSITIONS			THICKNESS OF EACH TEST PLATE	THICKNESS RANGE QUALIFIED	POSITION QUALIFIED
		1G	3G	4G			
SMAW	E7018 E7016	--	1	1	1"	1/8" & OVER	ALL
GMAW	E70S-X ER70S-X	--	1	1	3/8"	1/8" – 3/4"	ALL
FCAW	E71T-X	--	1	1	1"	1/8" & OVER	ALL
GTAW	ER70S-X	--	1	1	3/8"	1/8" – 3/4"	ALL
SAW	F7X - EXXX	1	--	--	1"	1/8" & OVER	FLAT

TABLE 27-13-B
SPECIFICATIONS FOR *SHOP* CERTIFICATION
STRUCTURAL WELDER – PLATE

	USE ELECTRODE WITH AWS DESIGNATION	QUANTITY OF TEST PLATES TO WELD IN POSITIONS			THICKNESS OF EACH TEST PLATE	THICKNESS RANGE QUALIFIED	POSITION QUALIFIED
		1G	2G	3G			
SMAW	E7018 E7016	--	1	-- OR 1	1"	1/8" & OVER	FH FHV
GMAW	E70S-X ER70S-X	--	1	-- OR 1	3/8"	1/8" – 3/4"	FH FHV
FCAW	E71T-X	--	1	-- OR 1	1"	1/8" & OVER	FH FHV
GTAW	ER70S-X	--	1	-- OR 1	3/8"	1/8" – 3/4"	FH FHV
SAW	F7X - EXXX	1	--	--	1"	1/8" & OVER	FLAT

TABLE 27-13-C
SPECIFICATIONS FOR *FIELD* CERTIFICATION
STRUCTURAL WELDER – PIPE

	USE ELECTRODE WITH AWS DESIGNATION	QUANTITY OF TEST PLATES TO WELD IN POSITIONS		TEST PIPE SIZE	PIPE SIZE QUALIFIED	MATERIAL THICKNESS QUALIFIED	PIPE OR PLATE POSITION QUALIFIED
		2G	5G				
SMAW	E7018* E7016*	(1 & 1)	OR 1	8" SCHEDULE 80 1/2"	4" OR LARGER	3/16" & OVER	ALL
GMAW	E70S-X ER70S-X	(1 & 1)	OR 1		OR	4" OR LARGER	3/16" & OVER
FCAW	E71T-X	(1 & 1)	OR 1	6" SCHEDULE 120 9/16"	4" OR LARGER	3/16" & OVER	ALL
GTAW	ER70S-X	(1 & 1)	OR 1		4" OR LARGER	3/16" & OVER	ALL

*ROOT PASS MAY BE E6010, E6011, OR GTAW

TABLE 27-13-D
SPECIFICATIONS FOR *SHOP* CERTIFICATION
STRUCTURAL WELDER – PIPE

	USE ELECTRODE WITH AWS DESIGNATION	QUANTITY OF TEST PLATES TO WELD IN POSITIONS		TEST PIPE SIZE	PIPE SIZE QUALIFIED	MATERIAL THICKNESS QUALIFIED	PIPE OR PLATE POSITION QUALIFIED
		2G	5G				
SMAW	E7018*	1	--	8" SCHEDULE 80 1/2" OR 6" SCHEDULE 120 9/16"	4" OR LARGER	3/16" & OVER	FH ALL
	E7016*	OR	1				
GMAW	E70S-X	1	--		4" OR LARGER	3/16" & OVER	FH ALL
	ER70S-X	OR	1				
FCAW	E71T-X	1	--	4" OR LARGER	3/16" & OVER	FH ALL	
		OR	1				
GTAW	ER70S-X	1	--	4" OR LARGER	3/16" & OVER	FH ALL	
		OR	1				

*ROOT PASS MAY BE E6010, E6011, OR GTAW

TABLE 27-13-E
SPECIFICATIONS FOR *FIELD & SHOP* CERTIFICATION
T-, K-, AND Y-CONNECTIONS – PIPE OR TUBING

	USE ELECTRODE WITH AWS DESIGNATION	QUANTITY OF TEST PLATES TO WELD IN POSITIONS		TEST PIPE SIZE	PIPE SIZE QUALIFIED	MATERIAL THICKNESS QUALIFIED	PIPE OR PLATE POSITION QUALIFIED
		6GR					
SMAW	E7018*	1		AT LEAST 1/2" THICK	T, Y, AND K CONNECTIONS	3/16" & OVER	ALL
	E7016*						
GMAW	E70S-X	1			T, Y, AND K CONNECTIONS	3/16" & OVER	ALL
	ER70S-X						
FCAW	E71T-X	1	T, Y, AND K CONNECTIONS	3/16" & OVER	ALL		
GTAW	ER70S-X	1	T, Y, AND K CONNECTIONS	3/16" & OVER	ALL		

*ROOT PASS MAY BE E6010, E6011, OR GTAW

TABLE 27-13-F
SPECIFICATIONS FOR *FIELD* CERTIFICATION
SHEET STEEL FILLET WELDER

	USE ELECTRODE WITH AWS DESIGNATION	QUANTITY OF TEST PLATES TO WELD IN POSITIONS	THICKNESS OF EACH TEST PLATE	THICKNESS RANGE QUALIFIED	POSITION QUALIFIED
		<u>3F</u> <u>4F</u>			
SMAW	E6011 E6010	1 1	16 GA. Galvanized to ¼" – ½" uncoated plate, tee joint	1/16" – 1/8"	ALL
GMAW	E70S-X ER70S-X	1 1		1/16" – 1/8"	ALL
FCAW	E71T-X	1 1		1/16" – 1/8"	ALL
GTAW	ER70S-X	1 1	16 GA. uncoated sheet to ¼" – ½" plate tee joint	1/16" – 1/8"	ALL

TABLE 27-13-G
SPECIFICATIONS FOR *SHOP* CERTIFICATION
SHEET STEEL FILLET WELDER

	USE ELECTRODE WITH AWS DESIGNATION	QUANTITY OF TEST PLATES TO WELD IN POSITIONS	THICKNESS OF EACH TEST PLATE	THICKNESS RANGE QUALIFIED	POSITION QUALIFIED
		<u>3F</u>			
SMAW	E6010 E6011	1	16 GA. Galvanized to ¼" – ½" uncoated plate, tee joint	1/16" – 1/8"	FHV
GMAW	E70S-X	1		1/16" – 1/8"	FHV
FCAW	E71T-X	1		1/16" – 1/8"	FHV
GTAW	ER70S-X	1	16 GA. uncoated sheet to ¼" – ½" plate tee joint	1/16" – 1/8"	FHV

TABLE 27-13-H
SPECIFICATIONS FOR REINFORCING STEEL WELDER

	USE ELECTRODE WITH AWS DESIGNATION	QUANTITY OF TEST PLATES TO WELD IN POSITIONS	BAR SIZE TESTED	BAR SIZE QUALIFIED	POSITION QUALIFIED
		<u>3G</u> <u>4G</u>			
SMAW	E7018 E7016 E8018	2 2	NO. 4	NO. 4 & ABOVE	ALL
GMAW	E70S-X	2 2	NO. 4	NO. 4 & ABOVE	ALL
FCAW	E71T-X	2 2	NO. 4	NO. 4 & ABOVE	ALL

Note: Welder may rotate test piece 180° allowing both sides to be welded in the overhead position.
The Welder Examiner may choose to lower the test plate.

TABLE 27-13-I
LIMITATION OF CERTIFICATIONS

CATEGORY OF WELDER CERTIFICATE AND TEST REQUIRED					The Welder/Welding Operator is qualified for the following:
Reinforcing Steel Welder	Structural Welder		Sheet Steel Welder	Welding Operator	
Indirect Butt Joint	Groove Plate Test	Pipe Butt & T-K-Y Connection Test	Fillet Weld Test	Groove Plate Test	
	X	X		X	<ol style="list-style-type: none"> 1. All steels listed in Table 27-13-J with yield strengths of 60 ksi or less, and other carbon steels of similar chemistry. Certification welding steels with yield strengths over 60 ksi requires a separate qualification test on that material (e.g., A514 or A572, Gr. 65; or A572, Gr. 70). 2. All those steels listed in this Standard, and other carbon steels of similar chemistry with yield strengths of 80 ksi or less. 3. Indirect butt joints, lap joints and for fillet welds bar to plate. Direct butt and bar to bar joints are not covered by this Standard. 4. The welding process and method used in qualification tests only (SMAW, GMAW, FCAW, SAW) certification for all others, including short circuiting ("Short Arc") GMAW, requires a separate qualification test. 5. All filler metals designated F4 and lower (SMAW process). See Table 27-13-L. 6. All filler metals of the same designation and lower strength than that used in the test. 7. Grooves and fillets, welding and tacking of plate and pipe or tubing over 24 inches in diameter. 8. Grooves and fillets, welding and tacking. 9. Fillet welding and tacking T-, butt- and lap-joints in sheet to sheet and sheet to supporting members. (Observe thickness and material limitation, 1/16 inch – 1/8 inch). 10. Equal to or less than 1/8 inch. 11. All sheet thicknesses between and including 1/16 inch and 1/8 inch. 12. All reinforcing steel no. 4 and above. 13. GTAW thickness between and including 1/8 inch and 3/4 inch. 14. GMAW thickness between and including 1/8 inch and 3/4 inch. 15. Welding with backing material in complete joint penetration welds welded from one side. 16. Welding with or without backing material in complete joint penetration welds welded from one side, if the qualification test is done without backing. 17. Welding of sheet to sheet and sheet to supporting members.
X			X		
X	X	X	X	X	
X	X	X			
X	X	X	X	X	
	X	X		X	
	X	X	X		
X			X		
	X				
	X	X		X	
	X	X			
			X		
			X		
			X		
			X		
			X		

ANY SEPARATE TESTS REQUIRED TO QUALIFY A WELDER FOR CONDITIONS NOT COVERED ARE TO BE APPROVED BY WABO AND ADMINISTERED BY A WABO QUALIFIED TESTING AGENCY.

**TABLE 27-13-J
MATCHING FILLER METAL REQUIREMENTS**

G R O U P	STEEL SPECIFICATION REQUIREMENTS			FILLER METAL REQUIREMENTS		
	Steel Specification	Minimum Yield Point ksi	Tensile Strength Range ksi	Electrode Specification	Minimum Yield Point ksi	Tensile Strength Range ksi
I	ASTM A36	36	58-809	SMAW		
	ASTM A53 Grade B	35	60 min			
	ASTM A106 Grade B	35	60 min	AWS A5.1 or A5.5		
	ASTM A131 Grades A, B, CS, D, DS, E	34	58-71	E7016, E7018	60	72 min
	ASTM A139 Grade B	35	60 min			
	ASTM A381 Grade Y35	35	60 min			
	ASTM A500 Grade A	33/39	45 min	SAW		
	ASTM A500 Grade B	41/46	58 min			
	ASTM A501	36	58 min	AWS A5.17 or A5.23		
	ASTM A516 Grade 55	30	55-65	F7X-EXXX	60	70-90
	ASTM A516 Grade 60	32	60-72			
	ASTM A524 Grade I	35	60-85			
	ASTM A524 Grade II	30	55-60			
	ASTM A529	42	60-85	GMAW		
	ASTM A1011 Grade 30	30	49 min			
	ASTM A1011 Grade 36	36	53 min			
	ASTM A1011 Grade 40	40	55 min	AWS A5.18		
	ASTM A1011 Grade 45	45	60 min	ER70S-X	60	72 min
	ASTM A1011 Grade 50	50	65 min			
	ASTM A573 Grade 65	35	65-77			
ASTM A709 Grade 36	36	58-80	FCAW			
API 5L Grade B	35	60				
API 5LX Grade X42	42	60	AWS A5.20			
ABS Grades A, B, D, CS, DS		58-71	E7XT-X	60	72 min	
Grade E		58-71	(except -2, -3, -10, -GS)			
II	ASTM A131 Grades AH32, DH32, EH32	45.5	68-85	SMAW		
	ASTM A131 Grades AH36, DH36, EH36	51	71-90	AWS A5.1 or A5.5		
	ASTM A242	42-50	63-70 min	E7016, E7018	60	72 min
	ASTM A441	42-50	63-70 min			
	ASTM A516 Grade 65	35	65-77			
	ASTM A516 Grade 70	38	70-85	SAW		
	ASTM A537 Class I	50	70-90			
	ASTM A572 Grade 42	42	60 min	AWS A5.17 or A5.23		
	ASTM A572 Grade 50	50	65 min	F7X-EXXX	60	70-90 min
	ASTM A588 (4: and under)	50	70 min			
	ASTM A595 Grade A	55	65 min			
	ASTM A595 Grades B and C	60	70 min			
	ASTM A606	45	65 min	GMAW		
	ASTM A1008/A1011 Grade 45	45	60 min			
	ASTM A1008/A1011 Grade 50	50	65 min			
	ASTM A1008/A1011 Grade 55	55	70 min	AWS A5.18		
	ASTM A618 Grades I b, II, III	50	65 min	ER70S-X	60	72 min
	ASTM A633 Grades A, B	42	63-83			
	ASTM A633 Grades C, D (2-1/2" and under)	50	70-90			
	ASTM A709 Grade 50	50	65 min	FCAW		
ASTM A709 Grade 50W	50	70 min				
ASTM A710 Grade A, Class 2 (2" and over)	55	65 min	AWS A5.20			
ASTM A710 Grade A, Class 2 (2-1/2" and under)	42	60 min	E7XT-X	60	72 min	
ASTM A808 (2-1/2" and under)	42	62-80	(Except -2, -3, -10, -GS)			
API 2H	42	62-80				
API 5LX Grade X52	52	66-72				
ABS Grades AH32, CH32, EH32	45.5	71-90				
ABS Grades AH36, DH36, EH36	51	71-90				

TABLE 27-13-K
SHEET STEEL

Steel Specification	Minimum Yield Point ksi	Minimum Tensile Strength ksi	Filler Metal Requirements
A653	Gr A	33	SMAW AWS A5.1 or A5.5 E6010
	Gr B	37	
	Gr C	40	
A1011	Gr A	25	SMAW AWS A5.1 or A5.5 E6010 E6011
	Gr B	30	
	Gr C	33	
	Gr D	40	
	Gr E	42	
A606		45	GMAW AWS A5.18 E70S-X
A1008/ A1011		60	
	Gr 45	45	FCAW AWS A5.20 E71T-X
	Gr 50	50	
A1008	Gr A	25	
	Gr B	30	
	Gr C	33	
	Gr D	40	

TABLE 27-13-L
FILLER METAL NUMBERS – SMAW PROCESS

Group Designation	AWS Electrode Classification*
F4	EXX15, EXX16, EXX18
F3	EXX10, EXX11
F2	EXX12, EXX13, EXX14
F1	EXX20, EXX24, EXX27, EXX28
<p>*The letters “XX” used in the classification-designation in this table stand for the various strength levels (60, 70, 80, 90, 100 and 120) for deposited weld metal.</p>	

TABLE 27-13-M**NOMINAL DIMENSIONS OF STANDARD REINFORCING BARS**

Bar Size ^{1,2}		Unit Weight		Diameter		Cross-Sectional Area	
in.	mm	lb/ft	kg/m	in.	mm	in. ²	mm ²
3	10	0.376	0.56	0.375	9.52	0.11	71.0
4	13	0.668	1.00	0.500	12.70	0.20	129.0
5	16	1.043	1.55	0.625	15.88	0.31	200.0
6	19	1.502	2.26	0.750	19.05	0.44	283.9
7	22	2.044	3.64	0.875	22.22	0.60	387.1
8	25	2.670	3.98	1.000	25.40	0.79	509.7
9	29	3.400	5.07	1.128	28.65	1.00	645.2
10	32	4.303	6.41	1.270	32.26	1.27	819.4
11	36	5.313	7.92	1.410	35.81	1.56	1006.5
14	43	7.65	11.40	1.693	43.00	2.25	1451.7
18	57	13.60	20.26	2.257	57.33	4.00	2580.8

Notes:

1. The nominal dimensions of a deformed bar are equivalent to those of a plain round bar having the same weight per foot as the deformed bar.
2. The bar size number is based on the number of eighths of an inch in the nominal diameter of the bar.

TABLE 27-13-N
DESIGNATION OF WELDING AND ALLIED PROCESSES
(Alphabetically by Process)

Welding and allied processes	Letter designation	Welding and allied processes	Letter designation
adhesive bonding	ABD	resistance welding	RW
arc welding	AW	flash welding	FW
atomic hydrogen welding	AHW	high frequency resistance welding	HFRW
bare metal arc welding	BMAW	percussion welding	PEW
carbon arc welding	CAW	projection welding	RPW
electro gas welding*	EGW	resistance seam welding	RSEW
flux cored arc welding	FCAW	resistance spot welding	RSW
gas metal arc welding	GMAW	upset welding	UW
gas tungsten arc welding	GTAW	soldering	S
plasma arc welding	PAW	dip soldering	DS
shielded metal arc welding	SMAW	furnace soldering	FS
stud arc welding	SW	induction soldering	IS
submerged arc welding	SAW	infrared soldering	IRS
arc welding process variations		iron soldering	INS
gas carbon arc welding	CAW-G	resistance soldering	RS
gas metal arc welding - pulsed arc	GMAW-P	torch soldering	TS
gas metal arc welding - short circuiting arc	GMAW-S	wave soldering	WS
gas tungsten arc welding - pulsed arc	GTAW-P	solid state welding	SSW
series submerged arc welding	SAW-S	cold welding	CW
shielded carbon arc welding	CAN-S	diffusion welding	DFW
twin carbon arc welding	CAW-T	explosion welding	EXW
brazing	B	forge welding	FOW
arc brazing	AB	friction welding	FRW
block brazing	BB	hot pressure welding	HPW
diffusion brazing	DFB	roll welding	ROW
dip brazing	DB	ultrasonic welding	USW
flow brazing	FLB	thermal cutting	TC
furnace brazing	FB	arc cutting	AC
induction brazing	IB	air carbon arc cutting	AAC
infrared brazing	IRB	carbon arc cutting	CAC
resistance brazing	RB	gas metal arc cutting	GMAC
torch brazing	TB	gas tungsten arc cutting	GTAC
twin carbon arc brazing	TCAB	metal arc cutting	MAC
other welding processes		plasma arc cutting	PAC
electron beam welding	EBW	shielded metal arc cutting	SMAC
electroslag welding	ESW	electron beam cutting	EBC
flow welding	FLOW	laser beam cutting	LBC
induction welding	IW	oxygen cutting	OC
laser beam welding	LBW	chemical flux cutting	FOC
thermit welding	TW	metal powder cutting	POC
oxyfuel gas welding	OFW	oxyfuel gas cutting	OFC
air acetylene welding	AAW	oxyacetylene cutting	OFC-A
oxyacetylene welding	OAW	oxyhydrogen cutting	OFC-H
oxyhydrogen welding	OHW	oxynatural gas cutting	OFC-N
pressure gas welding	PGW	oxypropane cutting	AOC
		oxygen arc cutting	AOC
		oxygen lance cutting	LOC
		thermal spraying	THSP
		electric arc spraying	EASP
		flame spraying	FLSP
		plasma spraying	PSP

*In the 1976 edition of AWS A24, electro gas welding was designated FCAW-EG and GMAW-EG, depending on the manner of application.

TABLE 27-13-O
DESIGNATION OF WELDING AND ALLIED PROCESSES
 (Alphabetically by Designation)

Letter designation	Welding and allied processes	Letter designation	Welding and allied processes
AAC	air carbon cutting	IB	induction brazing
AAW	air acetylene welding	INS	iron soldering
ABD	adhesive bonding	IRB	infrared brazing
AB	arc brazing	IRS	infrared soldering
AC	arc cutting	IS	induction soldering
AHW	atomic hydrogen welding	IW	induction welding
AOC	oxygen arc cutting	LBC	laser beam cutting
AU	automatic	LBW	laser beam welding
AN	arc welding	LOC	oxygen lance cutting
B	brazing	MA	manual
BB	block brazing	MAC	metal arc cutting
BMAW	bare metal arc welding	ME	machine
CAC	carbon arc cutting	OAW	oxyacetylene welding
CAW	carbon arc welding	OC	oxygen cutting
CAW-G	gas carbon arc welding	OFC	oxyfuel gas cutting
CAW-S	shielded carbon arc welding	OFC-A	oxyacetylene cutting
CAW-T	twin carbon arc welding	OFC-H	oxyhydrogen cutting
CW	cold welding	OFC-N	oxynatural gas cutting
DB	dip brazing	OFC-P	oxypropane, cutting
DFB	diffusion brazing	OFW	oxyfuel gas welding
DFW	diffusion welding	OHW	oxyhydrogen welding
DS	dip soldering	PAC	plasma arc cutting
EASP	electric arc spraying	PAW	plasma arc welding
EBC	electron beam cutting	PEW	percussion welding
EBW	electron beam welding	PGW	pressure gas welding
EGW	electrode gas welding	POC	metal powder cutting
ESW	electroslag welding	PSP	plasma spraying
EXW	explosion welding	RB	resistance brazing
FB	furnace brazing	RPW	projection welding
FCAW	flux cored arc welding	RS	resistance soldering
FLB	flow brazing	RSEW	resistance seam welding
FLOW	flow welding	RSW	resistance spot welding
FLSP	flame spraying	ROW	roll welding
FOC	chemical flux cutting	RW	resistance welding
FOW	forge welding	S	soldering
FRW	friction welding	SA	semiautomatic
FS	furnace soldering	SAW	submerged arc welding
FW	flash welding	SAW-S	series submerged arc cutting
GMAC	gas metal arc cutting	SMAC	shielded metal arc cutting
GMAW	gas metal arc welding	SMAK	shielded metal arc -welding
GMAW-P	gas metal arc welding - pulsed arc	SSW	solid state welding
GMAW-S	gas metal arc welding - short circuiting arc	SW	stud arc welding
GTAC	gas tungsten arc cutting	TB	torch brazing
GTAW	gas tungsten arc welding	TC	thermal cutting
GTAW-P	gas tungsten arc welding pulsed arc	TCAB	twin carbon arc brazing
HFRW	high frequency resistance welding	THSP	thermal spraying
HPW	hot pressure welding	is	torch soldering
		TW	thermit welding
		UsW	ultrasonic welding
		UW	upset welding

Table 27-13-P
STANDARD WELDING SYMBOLS

Basic Welding Symbols and Their Location Significance								
Location Significance	Fillet	Plug or Slot	Spot or Projection	Seam	Back or Backing	Surfacing	Scarf for Brazed Joint	Flange Edge
Arrow Side								
Other Side						Not used		
Both Side		Not used	Not used	Not used	Not used	Not used		Not used
No Arrow Side or Other Side Significance	Not used	Not used			Not used	Not used	Not used	Not used

Supplementary Symbols Used with Welding Symbols						
Convex Contour Symbol	Weld-All-Around Symbol					
<p>Convex contour symbol indicates face of weld to be finished to convex contour</p> <p>Finish symbol (user's standard) indicates method of obtaining specific contour but not degree of finish.</p>	<p>Weld-all-around symbol indicates that weld extends completely around the joint.</p>					
Joint with Backing	Joint with Spacer	Melt-Thru Symbol				
<p>With groove weld symbol</p> <p>Note: Material and dimensions of spacer are as specified</p>	<p>With Modified groove weld symbol</p> <p>Note: Material and dimensions of spacer are as specified</p>	<p>Any applicable weld symbol</p> <p>Melt-thru symbol is not dimensioned (except height)</p>				
Flush Contour Symbol	Multiple Reference Lines					
<p>Flush contour symbol indicates face of weld to be made flush. When used without a finish symbol, indicates weld without subsequent finishing.</p> <p>Finish symbol (user's standard) indicates method of obtaining specified contour but not degree of finish</p>	<p>First operation shown on reference line nearest arrow</p> <p>2nd: Second operation, or supplementary data</p> <p>3rd: Third operation, or test information</p>					
Field Weld symbol	Complete Penetration	Location of Elements of a Welding Symbol				
<p>Field Weld symbol indicates that weld is to be made at a place other than that of initial construction</p>	<p>Indicates complete penetration regardless of type of weld or joint preparation</p>	<p>Labels in diagram: Finish symbol, Contour symbol, Groove angle: included angle of countersink for plug welds, Length of weld, Pitch (center-to-center spacing) of welds, Field weld symbol, Arrow connecting reference line to arrow side member of joint, Weld-all-around symbol, Reference line, Elements in this area remain as shown when tail and arrow are reversed, Number of spot or projection welds, Tail (Tail omitted when reference is not used), Basic weld symbol or detail reference, Depth of preparation; size or strength for certain welds specification, process, or other reference, Root opening: depth of filling for plug and slot welds, Effective throat, (BOTH SIDES), (ARROW SIDE), (OTHER SIDE), 1st, 2nd, 3rd, L-P, F, A, P, S, E, T, CP.</p>				
Supplementary Symbols						
Weld-All-Around	Field Weld	Melt-Thru	Backing, Spacer	Contour		
				Flush	Convex	Concave

Table 27-13-P
STANDARD WELDING SYMBOLS
 (continued)

Basic Joints-Identification of Arrow Side and Other Side of Joint

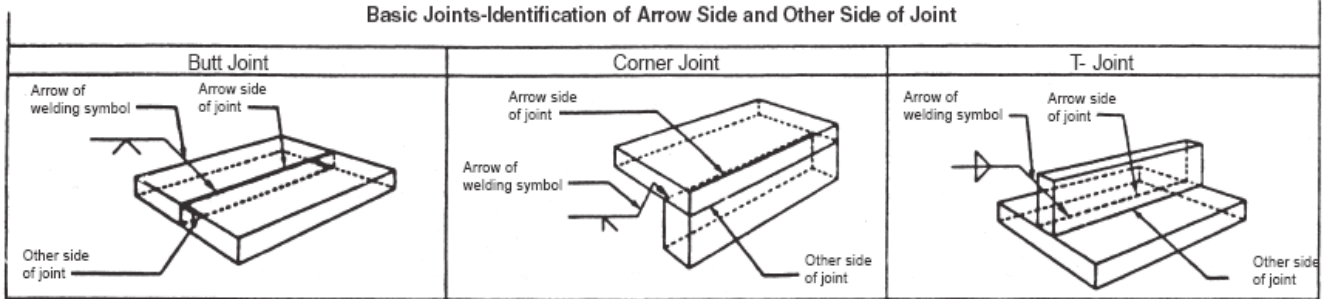

Flange	Groove							Location Significance
	Corner	Square	V	Bevel	U	J	Flare-V	
								Arrow Side
								Other Side
Not Used								Both Sides
Not Used		Not Used	Not Used	Not Used	Not Used	Not Used	Not Used	No Arrow Side or Other Side Significance

Typical Welding Symbols

<p>Slot Welding Symbol</p> <p>Depth of filling in inches (omission indicates filling is complete)</p> <p>Orientation, location and all dimensions other than depth of filling are shown on the drawing</p>	<p>Square-Groove Welding Symbol</p> <p>Omission of size indicates complete joint penetration</p> <p>Root opening</p>	<p>Flare-V and Flare-Bevel-Groove Welding Symbol</p> <p>Root opening</p> <p>Size is considered as extending only to tangent points</p> <p>Root opening</p>
<p>Plug Welding Symbol</p> <p>Included angle of countersink</p> <p>Pitch (distance between centers) of welds</p> <p>Depth of filling in inches (omission indicates filling is complete)</p> <p>Size (diameter of hole as root)</p>	<p>Chain Intermittent Fillet Welding Symbol</p> <p>Pitch (distance between centers) of increments</p> <p>Length of increments</p> <p>Size (length of leg)</p>	<p>Edge-and-Corner-Flange Welding Symbol</p> <p>Radius</p> <p>Size of weld</p> <p>height above point of tangency</p>
<p>Background Welding Symbol</p> <p>Back Gouge</p> <p>Second reference line used for back gouging and welding as a second operation</p> <p>Note: Total effective throat not to exceed thickness of member</p>	<p>Back or Backing Welding Symbol</p> <p>Any applicable single groove weld symbol</p>	<p>Surfacing Welding Symbol Indicating Built-up Surface</p> <p>Orientation, location and all dimensions other than size are shown on the drawing</p>
<p>Flash or Upset Welding Symbol</p> <p>No arrow side or other side significance</p> <p>Process references must be used to indicate process desired</p>	<p>Staggered Intermittent Fillet Welding Symbol</p> <p>Pitch (distance between centers) of increments</p> <p>Length of increments</p> <p>Size (length of leg)</p>	<p>Single-V Groove Welding Symbol Indication Root Penetration</p> <p>Size</p> <p>Depth of preparation</p> <p>Effective throat</p> <p>Root opening</p> <p>Groove angle</p>
<p>Spot Welding Symbol</p> <p>Size (diameter of weld) Strength (in lb per weld) may be used instead</p> <p>Number of welds</p> <p>Pitch (distance between centers) of weld</p> <p>Process reference must be used to indicate process desired</p>	<p>Double-Bevel-Groove Welding Symbol</p> <p>Arrow points toward member to be prepared</p> <p>Omission of size dimension indicates a total depth of preparation equal to thickness of members</p> <p>Root opening</p> <p>Groove angle</p>	
<p>Seam Welding Symbol</p> <p>Length of weld or increments</p> <p>Omission indicates that weld extends between abrupt changes in direction or as dimensioned</p> <p>Size (width of weld) Strength (in lb per linear inch) may be used instead</p> <p>Pitch (distance between centers) of increments</p> <p>Process reference must be used to indicate process desired</p>	<p>Projection Welding Symbol</p> <p>Projection welding reference must be used</p> <p>Size (strength in lb per weld) Diameter of weld may be used instead for circular projection welds</p> <p>Pitch (distance between centers) of welds</p> <p>Number of welds</p>	

Table 27-13-P
STANDARD WELDING SYMBOLS
 (continued)

Welding Symbols for Combined Welds		Double-Fillet Welding Symbol	
		Size (length of leg)	Length Omission indicates that weld extends between abrupt changes in direction or as dimensioned
		Specification, process, or other reference	
Basic Joints-Identification of Arrow Side and Other Side of Joint			Process Abbreviations
Lap Joint		Edge Joint	
			<p>Where process abbreviations are to be included in the tail of the welding symbol, reference is made to Table A, Designation of Welding and Allied Processes by letters. Of AWS 2.4-79.71.</p> <p align="center">AMERICAN WELDING SOCIETY, INC. 2501 N 7th Street, Miami, Florida 33125</p>

Table 27-13-Q
TERMS AND DEFINITIONS

ALL-WELD-METAL TEST SPECIMEN - A test specimen with the reduced section composed wholly of weld metal.

ANGLE OF BEVEL - See preferred term *bevel angle*.

ARC GOUGING - An arc cutting procedure used to form a bevel or groove.

AS-WELDED - The condition of weld metal, welded joints and weldments after welding prior to any subsequent thermal, mechanical, or chemical treatments.

AUTOMATIC WELDING - Welding with equipment which performs the welding operation without adjustment of the controls by a welding operator. The equipment may or may not perform the loading and unloading of the work. See *machine welding*.

AXIS OF A WELD - A line through the length of a weld perpendicular to and at the geometric center of its cross section.

BACK GOUGING - The removal of weld metal and base metal from the other side of a partially welded joint to assure complete penetration upon subsequent welding from that side.

BACKING - Material (metal, weld metal, carbon or granular) placed at the root of a weld joint for the purpose of supporting molten weld metal.

BACKING PASS - A pass made to deposit a backing weld.

BACKING RING - Backing in the form of a ring, generally used in the welding of piping.

BACKING STRAP - See preferred term *backing strip*.

BACKING STRIP - Backing in the form of a strip.

BACKING WELD - Backing in the form of a weld.

BACKUP WELD (tubular structures) - The initial closing pass in a complete joint penetration groove weld, made from one side only, which serves as a backing for subsequent welding but is not considered as a part of the theoretical weld.

BACK WELD - A weld deposited at the back of a single-groove weld.

BASE METAL - The metal to be welded, soldered, or cut.

BEVEL ANGLE - The angle formed between the prepared edge of a member and a plane perpendicular to the surface of the member.

BOXING - The continuation of a fillet weld around a corner of a member as an extension of the principal weld.

BUTT JOINT - A joint between two members aligned approximately in the same plane.

BUTT WELD - An erroneous term for a weld in a butt joint. See butt joint.

COMPLETE FUSION - Fusion that has occurred over the entire base material surfaces intended for welding and between all layers and weld beads.

COMPLETE JOINT PENETRATION - Joint penetration in which the weld metal completely fills the groove and is fused to the base metal throughout its total thickness.

COMPLETE PENETRATION - See preferred term *complete joint penetration*.

CONSUMABLE GUIDE ELECTROSLAG WELDING - See *electroslag welding*.

CONTINUOUS WELD - A weld which extends continuously from one end of a joint to the other. Where the joint is essentially circular, it extends completely around the joint.

CORNER JOINT - A joint between two members located approximately at right angles to each other.

CO₂ WELDING - See preferred term *gas metal arc welding*.

CRATER - In arc welding, a depression at the termination of a weld bead or in the molten weld pool.

DEFECT - A discontinuity or discontinuities which by nature or accumulated effect render a part or product unable to meet minimum applicable acceptance standards or specifications. This term designates rejectability.

DEFECTIVE WELD - A weld containing one or more defects.

DEPTH OF FUSION - The distance that fusion extends into the base metal or previous pass from the surface melted during welding.

DISCONTINUITY - An interruption of the typical structure of a weldment such as a lack of homogeneity in the mechanical or metallurgical or physical characteristics of the material or weldment. A discontinuity is not necessarily a defect.

DOWNHAND - See preferred term *flat position*.

EFFECTIVE LENGTH OF WELD - The length of weld throughout which the correctly proportioned cross section exists. In a curved weld, it shall be measured along the axis of the weld.

ELECTROGAS WELDING (EGW) - An arc welding process which produces coalescence of metals by heating with an arc between a continuous filler metal (consumable) electrode and the work. Molding shoe(s) are used to confine the molten weld metal for vertical position welding. The electrodes may be either flux cored or solid. Shielding may or may not be obtained from an externally supplied gas or mixture.

ELECTROSLAG WELDING (ESW) - A welding process producing coalescence of metals with molten slag which melts the filler metal and the surfaces of the work to be welded. The molten weld pool is shielded by this slag which moves along the FULL cross section of the joint as welding progresses. The process is initiated by an arc which heats the slag. The arc is then extinguished and the conductive slag is maintained in a molten condition by its resistance to electric current passing between the electrode and the work.

CONSUMABLE GUIDE ELECTROSLAG WELDING - A method of electroslag welding in which filler metal is supplied by an electrode and its guiding member.

FAYING SURFACE - The mating surface of a member which is in contact or in close proximity with another member to which it is to be joined.

FILLER METAL - The metal to be added in making a welded joint. See *electrode* and *welding rod*.

FLARE-BEVEL-GROOVE WELD - A weld in a groove formed by a member with a curved surface in contact with a planar member.

FLARE-V-GROOVE WELD - A weld in a groove formed by two members with curved surfaces.

FLASH - The material which is expelled or squeezed out of a weld joint and which forms around the weld.

FLAT POSITION - The welding position used to weld from the upper side of the joint and the face of the weld is approximately horizontal.

FLUX CORED ARC WELDING (FCAW) - An arc welding process which produces coalescence of metals by heating them with an arc between a continuous filler metal (consumable) electrode and the work. Shielding is provided by a flux contained within the electrode. Additional shielding may or may not be obtained from an externally supplied gas or gas mixture.

FUSION - The melting together of filler metal and base metal, or the melting of base metal only, which results in coalescence. See *depth of fusion*

FUSION TYPE DISCONTINUITY - Signifies slag inclusion, incomplete fusion, incomplete joint penetration, and similar discontinuities associated with fusion.

FUSION ZONE - The area of base metal melted as determined on the cross section of a weld.

GAS METAL ARC WELDING (GMAW) - An arc welding process which produces coalescence of metals by heating them with an arc between a continuous filler metal (consumable) electrode and the

work. Shielding is obtained entirely from an externally supplied gas or gas mixture. Some methods of this process are called MIG or CO₂ welding (nonpreferred terms).

GAS METAL ARC WELDING - SHORT CIRCUIT ARC (GMAW-S) - A gas metal arc welding process variation in which the consumable electrode is deposited during repeated short circuits. Sometimes this process is referred to as MIG or CO₂ welding (nonpreferred terms).

GAS POCKET - A cavity caused by entrapped gas.

GOUGING - The forming of a bevel or groove by material removal. See also *back gouging*, *arc gouging*, and *oxygen gouging*.

GROOVE ANGLE - The total included angle of the groove between parts to be joined by a groove weld.

GROOVE FACE - That surface of a member included in the groove.

GROOVE WELD - A weld made in the groove between two members to be joined.

HEAT-AFFECTED ZONE - That portion of the base metal which has not been melted, but whose mechanical properties or microstructure have been altered by the heat of welding, brazing, soldering, or cutting.

HORIZONTAL FIXED POSITION (PIPE WELDING) - The position of a pipe joint in which the axis of the pipe is approximately horizontal and the pipe is not rotated during welding.

HORIZONTAL POSITION - FILLET WELD - The position in which welding is performed on the upper side of an approximately horizontal surface and against an approximately vertical surface.

HORIZONTAL POSITION - GROOVE WELD - The position of welding in which the axis of the weld lies in an approximately horizontal plane and the face of the weld lies in an approximately vertical plane.

HORIZONTAL ROLLED POSITION (PIPE WELDING) - The position of a pipe joint in which the axis of the pipe is approximately horizontal, and welding is performed in the flat position by rotating the pipe.

INERT GAS METAL ARC WELDING - See preferred term *gas metal arc welding*.

INTERMITTENT WELD - A weld in which the continuity is broken by recurring unwelded spaces.

INTERPASS TEMPERATURE - In a multiple-pass weld, the temperature (minimum or maximum as specified) of the deposited weld before the next pass is started.

JOIN - The junction of members of the edges of members that are to be joined or have been joined.

JOINT PENETRATION - The minimum depth of a groove or flange weld extends from its face into a joint exclusive of reinforcement. Joint penetration may include root penetration.

JOINT WELDING PROCEDURE - The materials and detailed methods and practices employed in the welding of a particular joint.

LAP JOINT - A joint between two overlapping members.

LAYER - A stratum of weld metal or surfacing material. The layer may consist of one or more welds beads laid side by side.

LEG OF A FILLET WELD - The distance from the root of the joint to the toe of the fillet weld.

MACHINE WELDING - Welding with equipment which performs the welding operation under the constant observation and control of an operator. The equipment may or may not perform the loading and unloading of the work. See *automatic welding*.

MANUAL WELDING - A welding operation performed and controlled completely by hand. See *automatic welding, machine welding, and semiautomatic welding*.

OVERHEAD POSITION - The position in which welding is performed from the underside of the joint.

OVERLAP - The protrusion of weld metal beyond the toe, face, or root of the weld.

OXYGEN CUTTING (OC) - A group of cutting processes used to sever or remove metals by means of the chemical reaction of oxygen with the base metal at elevated temperatures. In the case of oxidation-resistant metals, the reaction is facilitated by the use of a chemical flux or metal powder.

OXYGEN GOUGING - An application of oxygen cutting in which a bevel or groove is formed.

PARALLEL ELECTRODE - See *submerged arc welding (SAW)*.

PARTIAL JOINT PENETRATION - Joint penetration which is less than complete.

PASS - See preferred term *weld pass*.

PEENING - The mechanical working of metals using impact blows.

PIPE - Tubular-shaped product of circular cross section. See *tubular*

PIPING POROSITY (GENERAL) - Elongated porosity whose major dimension lies in a direction approximately normal to the weld surface. Frequently referred to as "pin holes" when the porosity extends to the weld surface.

PLUG WELD - A circular weld made through a hole in one member of a lap or T-joint fusing that member to the other. The walls of the hole may or may not be parallel and the hole may be partially or completely filled with weld metal. (A fillet welded hole or a spot weld should not be construed as conforming to this definition.)

POROSITY - Cavity type discontinuities formed by gas entrapment during solidification.

POSITIONED WELD - A weld made in a joint which has been so placed as to facilitate making the weld.

POSTWELD HEAT TREATMENT - Any heat treatment subsequent to welding. PREHEATING. The application of heat to the base metal immediately before welding, brazing, soldering, or cutting.

PREHEAT TEMPERATURE - A specified temperature that the base metal must attain in the welding, brazing, soldering, or cutting area immediately before these operations are performed.

PROCEDURE QUALIFICATION - The demonstration that welds made by a specific procedure can meet prescribed standards.

QUALIFICATION - See preferred terms *welder performance qualification* and *procedure qualification*.

RANDOM SEQUENCE - See preferred term *wandering sequence*.

REINFORCEMENT OF WELD - Weld metal in excess of the quantity required to fill a joint.

REJECTABLE DISCONTINUITY - See preferred term *defect*.

ROOT FACE - That portion of the groove face adjacent to the root of the joint.

ROOT GAP - See preferred term *root opening*.

ROOT OF JOINT - That portion of a joint to be welded where the members approach closest to each other. In cross section, the root of the joint may be either a point, a line, or an area.

ROOT OF WELD - The points, as shown in cross section, at which the back of the weld intersects the base metal surfaces.

ROOT OPENING - The separation, at the root of the joint, between the members to be joined.

SEMI-AUTOMATIC ARC WELDING - Arc welding with equipment which controls only the filler metal feed. The advance of the welding is manually controlled.

SHIELDED METAL ARC WELDING (SMAW) - An arc welding process which produces coalescence of metals by heating with an arc between a covered metal electrode and the work. Shielding is obtained from decomposition of the electrode covering. Pressure is not used and filler metal is obtained from the electrode.

SHIELDING GAS - Protective gas used to prevent atmospheric contamination.

SINGLE-WELDED JOINT - In arc and gas welding, any joint welded from one side only.

SIZE OF WELD:

GROOVE WELD - The joint penetration (depth of bevel plus the root penetration when specified). The size of a groove weld and its effective throat are one and the same.

FILLET WELD - *For equal leg fillet welds*, the leg length of the largest isosceles right triangle that can be inscribed within the fillet weld cross section. *For unequal leg fillet welds*, the length of the largest right triangle that can be inscribed within the fillet weld cross section.

Note: When one member makes an angle with the other member greater than 105 degrees, the leg length (size) is of less significance than the effective throat which is the controlling factor for the strength of a weld.

SLOT WELD - A weld made in an elongated hole in one member of a lap or T-joint joining that member to that portion of the surface of the other member which is exposed through the hole. The hole may be open at one end and may be partially or completely filled with weld metal. (A fillet welded slot should not be construed as conforming to this definition.)

SPATTER - The metal particles expelled during welding; they do not form a part of the weld.

STRINGER BEAD - A type of weld bead made without appreciable weaving motion.

STUD ARC WELDING (SW) - An arc welding process which produces coalescence of metals by heating with an arc between a metal stud or similar part and the other work part. When the surfaces to be joined are properly heated, they are brought together under pressure. Partial shielding may be obtained by the use of a ceramic ferrule surrounding the stud. Shielding gas or flux may or may not be used.

SUBMERGED ARC WELDING (SAW) - An arc welding process which produces coalescence of metals by heating with an arc or arcs between a bare metal electrode or electrodes and the work. The arc is shielded by a blanket of granular, fusible material on the work. Pressure is not used and filler metal is obtained from the electrode and sometimes from a supplementary welding rod.

SINGLE ELECTRODE - One electrode connected exclusively to one power source which may consist of one or more power units.

PARALLEL ELECTRODE - Two electrodes connected electrically in parallel and exclusively to the same power source. Both electrodes are usually fed by means of a single electrode feeder. Welding current, when specified, is the total for the two electrodes.

MULTIPLE ELECTRODES - The combination of two or more parallel electrode systems. Each of the component systems has its own independent power source and its own electrode feeder.

TACK WELD - A weld made to hold parts of a weldment in proper alignment until the final welds are made.

TACKER - A fitter, or someone under the direction of a fitter, who tack welds parts of a weldment to hold them in proper alignment until the final welds are made.

TANDEM - Refers to a geometrical arrangement of electrodes in which a line through the arcs is parallel to the direction of welding.

TEMPORARY WELD - A weld made to attach a piece or pieces to a weldment for temporary use in handling, shipping, or working on the weldment.

THROAT OF A FILLET WELD:

THEORETICAL THROAT - The distance from the beginning of the root of the joint perpendicular to the hypotenuse of the largest right triangle that can be inscribed within the fillet cross section.

ACTUAL THROAT - The shortest distance from the root of a fillet weld to its face.

THROAT OF A GROOVE WELD - See preferred term *size of weld*.

T-JOINT - A joint between two members located approximately at right angles to each other in the form of a T.

TOE OF WELD - The junction between the face of a weld and the base metal.

TRANSVERSE DISCONTINUITY - A weld discontinuity whose major dimension is in a direction perpendicular to the weld axis "X."

TUBULAR - Tubular products is a generic term for a family of hollow section products of various cross-sectional configuration. The term "pipe" denotes cylindrical products to differentiate from square and rectangular hollow section products. However, a tube or tubing can also be cylindrical. User should note the AISC designation of tubular sections: TSC x t for circular tubes (pipe) TSa x b x t for square and rectangular tubes (referred to collectively as box sections in Section 10) Where TS = the group symbol t nominal wall thickness D nominal outside diameter a nominal major width b nominal minor width

TUBULAR CONNECTION - A connection in the portion of a tubular structure which contains two or more intersecting tubular members.

TUBULAR JOINT - A joint in the interface created by one tubular member intersecting another.

UNDERCUT - A groove melted into the base metal adjacent to the toe or root of a weld and left unfilled by weld metal.

VERTICAL POSITION - The position of welding in which the axis of the weld is approximately vertical.

VERTICAL POSITION PIPE WELDING - The position of a pipe joint wherein welding is performed in the horizontal position and the pipe shall not be rotated during welding.

WANDERING SEQUENCE - A longitudinal sequence in which the weld bead increments are deposited at random.

WEAVE BEAD - A type of weld bead made with transverse oscillation.

WELD - A localized coalescence of metals produced either by heating to suitable temperatures, with or without the application of pressure or by the application of pressure alone, and with or without the use of filler metal.

WELDABILITY - The capacity of a metal to be welded under the fabrication conditions imposed into a specific suitably designed structure and to perform satisfactorily in the intended service.

WELD BEAD - A weld deposit resulting from a pass. See *stringer bead* and *weave bead*.

WELDER - One who performs a manual or semiautomatic welding operation.

WELDER CERTIFICATION - Certification in writing that a welder has produced welds meeting prescribed standards.

WELDER PERFORMANCE QUALIFICATION - The demonstration of a welder's ability to produce welds meeting prescribed standards.

WELDING - A metal joining process used in making welds.

WELDING MACHINE - Equipment used to perform the welding operation. For example, spot welding machine, arc welding machine, seam welding machine, etc.

WELDING OPERATOR - One who operates machine or automatic welding equipment.

WELDING PROCEDURE - The detailed methods and practices including all joint welding procedures involved in the production of a weldment. See *joint welding procedure*.

WELDING SEQUENCE - The order of making the welds in a weldment.

WELDMENT - An assembly whose component parts are joined by welding.



SAMPLE WELDING PROCEDURE SPECIFICATION

PREQUALIFIED SMAW
 Yes No

WPS # WABO 201

Supporting PQR #

JOINT DESIGN USED
Type: Butt- Single-Vee _____
 Single Double _____

POSITION
 Groove 3G, 4G Fillet _____

Backing: Yes No _____
 Material Type Mild steel
 Root Opening 1/4" Root Face N/A
 Groove Angle 45° Radius J-U N/A
 Back Gouging: Yes _____ No
 Method N/A

Vertical Progression:
 Up Down _____

BASE METALS
Material Spec. _____ Group I
 Type or Grade A36
 Thickness: _____
 Groove 1" Fillet _____
 Diameter (Pipe) _____

ELECTRICAL CHARACTERISTICS
Transfer Mode (GMAW)
 Short - Circuiting _____
 Globular _____
 Spray _____
 Current: _____
 AC _____
 DCEP
 DCEN _____
 Pulse _____

FILLER METALS
 AWS Specification AWS A5.1
 AWS Classification E-7018

TECHNIQUE
Bead Type:
 Stringer Weave _____
 Multi Pass
 Single Pass _____
 Stick Out N/A
 Interpass Cleaning Chip and wire brush.

SHIELDING
 Gas Type N/A
 Flow Rate N/A
 Gas Nozzle Size N/A

POSTWELD HEAT TREATMENT
 Temp. N/A
 Time. N/A

PREHEAT
 Preheat Temp., Min 50° F Max _____
 Interpass Temp., Min 50° F Max _____

BACK-BEAD N/A

WELDING PROCEDURE

PASS OR LAYERS **AMPS.**
 All 100-140

WIRE SPEED in/min
 N/A

PROCESS
 SMAW

VOLTAGE
 21-25

FILLER METALS
 E7018
 1/8" dia.

TRAVEL SPEED
 6-12 IPM

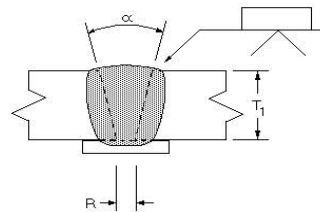

CURRENT
 DCEP

JOINT DETAILS $\alpha = 45^\circ$ $T = 1"$
 B-U2a $R = 1/4"$ maximum



SAMPLE WELDING PROCEDURE SPECIFICATION

PREQUALIFIED FCAW		WPS # WABO 301	
Yes	X	No	
JOINT DESIGN USED		POSITION	
Type:	Butt- Single-Vee	Groove	<u>3G, 4G</u> Fillet _____
Single	<u>X</u> Double _____		
Backing:	Yes <u>X</u> No _____	Vertical Progression:	Up <u>X</u> Down _____
Material Type	Mild steel	ELECTRICAL CHARACTERISTICS	
Root Opening Max.	<u>1/4"</u> Root Face <u>N/A</u>	Transfer Mode (GMAW)	
Groove Angle	<u>45°</u> Radius J-U <u>N/A</u>	Short - Circuiting _____	
Back Gouging:	Yes _____ No <u>X</u>	Globular _____	
Method	<u>N/A</u>	Spray <u>X</u>	
BASE METALS		Current: _____	
Material Spec.	Group I	AC _____	
Type or Grade	<u>A36</u>	DCEP <u>X</u>	
Thickness:		DCEN _____	
Groove	<u>1"</u> Fillet _____	Pulse _____	
Diameter (Pipe)		TECHNIQUE	
FILLER METALS		Bead Type:	
AWS Specification	<u>AWS A5.20</u>	Stringer <u>X</u> Weave _____	
AWS Classification	<u>E-71T-1</u>	Multi Pass <u>X</u>	
SHIELDING		Single Pass _____	
Gas Type	<u>75% Ar, 25% Co2</u>	Stick Out <u>1/4" - 3/4"</u>	
Flow Rate	<u>30-70 CFH</u>	Interpass Cleaning <u>Chip and wire brush.</u>	
Gas Nozzle Size	<u>All</u>	POSTWELD HEAT TREATMENT	
PREHEAT		Temp. <u>N/A</u>	
Preheat Temp., Min	<u>50°F</u> Max _____	Time. <u>N/A</u>	
Interpass Temp., Min	<u>50°F</u> Max _____	BACK-BEAD <u>N/A</u>	

WELDING PROCEDURE

PASS OR LAYERS	WIRE SPEED in/min	AMPS.
All	150 - 320 ipm	150-400
PROCESS	VOLTAGE	
FCAW	23-28	
FILLER METALS	TRAVEL SPEED	
E-71T-1	12 - 25 IPM	
.052" - 1/16"	JOINT DETAILS	$\alpha = 45^\circ$ R = 1/4" maximum
CURRENT	B-U2a-GF	T = 1"
DCEP		



SAMPLE WELDING PROCEDURE SPECIFICATION

PREQUALIFIED GMAW		WPS # WABO 401	
Yes	X	No	
JOINT DESIGN USED		POSITION	
Type:	Butt- Single-Vee	Groove	<u>3G, 4G</u> Fillet _____
Single	<u>X</u> Double _____		
Backing:	Yes <u>X</u> No _____	Vertical Progression:	
Material Type	Mild steel	Up	<u>X</u> Down _____
Root Opening Max.	<u>1/4"</u> Root Face <u>N/A</u>	ELECTRICAL CHARACTERISTICS	
Groove Angle	<u>45°</u> Radius J-U <u>N/A</u>	Transfer Mode (GMAW)	
Back Gouging:	Yes _____ No <u>X</u>	Short - Circuiting	<u>X</u>
Method	<u>N/A</u>	Globular	<u>X</u>
BASE METALS		Spray	<u>X</u>
Material Spec.	Group I	Current:	_____
Type or Grade	<u>A36</u>	AC	_____
Thickness:		DCEP	<u>X</u>
Groove	<u>3/8"</u> Fillet _____	DCEN	_____
Diameter (Pipe)		Pulse	_____
FILLER METALS		TECHNIQUE	
AWS Specification	<u>AWS A5.18</u>	Bead Type:	
AWS Classification	<u>E70S-3, E70S-4</u>	Stringer	<u>X</u> Weave _____
SHIELDING		Multi Pass	<u>X</u>
Gas Type	<u>75% Ar, 25% Co2</u>	Single Pass	_____
Flow Rate	<u>30-70 CFH</u>	Stick Out	<u>1/8" - 3/4"</u>
Gas Nozzle Size	<u>All</u>	Interpass Cleaning	<u>Chip and wire brush.</u>
PREHEAT		POSTWELD HEAT TREATMENT	
Preheat Temp., Min	<u>50°F</u> Max _____	Temp.	<u>N/A</u>
Interpass Temp., Min	<u>50°F</u> Max _____	Time.	<u>N/A</u>
		BACK-BEAD <u>N/A</u>	

WELDING PROCEDURE

PASS OR LAYERS	WIRE SPEED in/min	AMPS.
All	100 - 400 ipm	100-300
PROCESS	VOLTAGE	
GMAW	17-25	
FILLER METALS	TRAVEL SPEED	
E70S-3, E70S-4 .035"	6 - 18 ipm	
CURRENT	JOINT DETAILS	
DCEP	B-U2a-GF	$\alpha = 30^\circ$ T = 3/8" R = 1/4" maximum



SAMPLE WELDING PROCEDURE SPECIFICATION

Restricted Access Supplemental Welder Qualification Removable Backing

PREQUALIFIED

Yes No

WABO WPS # 102-10

Supporting PQR # prequalified

JOINT DESIGN USED

Type: Butt- Bevel Groove
Single Double

Backing: Yes No

Material Type Ceramic / Copper

Root Opening 3/8 Root Face N/A

Groove Angle 30° Radius J-U N/A

Back Gouging: Yes No

Method CAC-A

BASE METALS

Material Spec. Group I

Type or Grade A36 / A572 grd 50

Thickness: _____

Groove 1" Fillet _____

Diameter (Pipe) _____

FILLER METALS

AWS Specification AWS A5.1

AWS Classification E7018

SHIELDING

Gas Type N/A

Flow Rate N/A

Gas Nozzle Size N/A

PREHEAT

Preheat Temp., Min 50°F Max _____

Interpass Temp., Min 50°F Max _____

POSITION

Groove 1G

Fillet _____

Vertical Progression:

Up N/A Down N/A

ELECTRICAL CHARACTERISTICS

Transfer Mode (GMAW) N/A

Short - Circuiting N/A

Globular N/A

Spray N/A

Current: DCEP

AC

DCEP

DCEN

Pulse

TECHNIQUE

Bead Type:

Stringer Weave N/A

Multi Pass

Single Pass N/A

Stick Out N/A

Interpass Cleaning Chip and wire brush.

POSTWELD HEAT TREATMENT

Temp. N/A

Time. N/A

BACK-BEAD

Yes Back-bead must be welded in the overhead position.

WELDING PROCEDURE

PASS OR LAYERS

All

WIRE SPEED in/min

N/A

AMPS.

180-300

PROCESS

SMAW

VOLTAGE

21-25

FILLER METALS

E7018

3/16" dia.

TRAVEL SPEED

6-15 IPM

CURRENT

DCEP

JOINT DETAILS

B-U4a

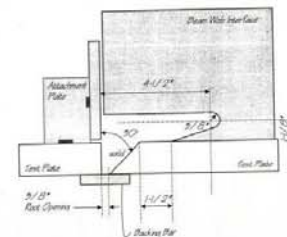



SAMPLE WELDER QUALIFICATION PROCEDURE

Seismic Restricted Access Supplemental Welder Qualification

PREQUALIFIED

 Yes No
JOINT DESIGN USED
Type: Butt- Bevel Groove
 Single Double
Backing: Yes No

 Material Type Mild Steel
 Root Opening 3/8 Root Face N/A
 Groove Angle 30° Radius J-U N/A
Back Gouging: Yes No

Method _____

BASE METALS

 Material Spec. Group I & II
 Type or Grade A36 / A572 gr. 50
 Thickness: _____
 Groove 1" Fillet _____
 Diameter (Pipe) _____

FILLER METALS

 AWS Specification AWS A5.20
 AWS Classification E71T-6
SHIELDING

 Gas Type N/A
 Flow Rate N/A
 Gas Nozzle Size N/A
PREHEAT

 Preheat Temp., Min 50°F Max _____
 Interpass Temp., Min 50°F Max _____

 WABO WPS # 101-6

 Supporting PQR # prequalified
POSITION

 Groove 1G Fillet _____

Vertical Progression:

Up _____ Down _____

TECHNIQUE
Bead Type:

 Stringer Weave _____

 Multi Pass

Single Pass _____

 Stick Out 1"

 Interpass Cleaning Chip and wire brush.
POSTWELD HEAT TREATMENT

 Temp. N/A

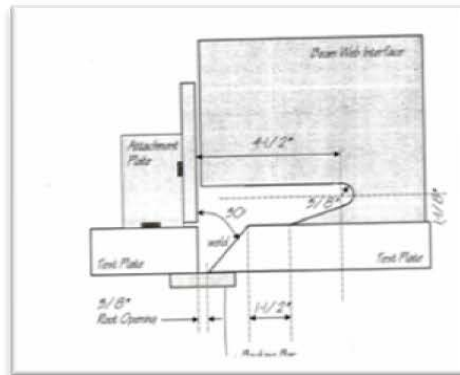
 Time. N/A

WELDING PROCEDURE

PASS OR LAYERS

All

WIRE SPEED in/min

200-400 imp

AMPS.

275-475

PROCESS

FCAW-S

VOLTAGE

23-27

FILLER METALS

E71T-6

5/64"

TRAVEL SPEED

15-30 ipm

CURRENT

DCEP

JOINT DETAILS

B-U4a-GF



SAMPLE WELDER QUALIFICATION PROCEDURE

Seismic Restricted Access Supplemental Welder Qualification

PREQUALIFIED

Yes No

JOINT DESIGN USED

Type: Butt- Bevel Groove
Single Double

Backing: Yes No

Material Type Mild Steel

Root Opening 3/8 Root Face N/A

Groove Angle 30° Radius J-U N/A

Back Gouging: Yes No

Method

BASE METALS

Material Spec. Group I & II

Type or Grade A36 / A572 gr. 50

Thickness:

Groove 1" Fillet

Diameter (Pipe)

FILLER METALS

AWS Specification AWS A5.20

AWS Classification E71T-8 (ESAB Core Shield 8)

SHIELDING

Gas Type N/A

Flow Rate N/A

Gas Nozzle Size N/A

PREHEAT

Preheat Temp., Min 50°F Max

Interpass Temp., Min 50°F Max

WABO WPS # 101-8

Supporting PQR # prequalified

POSITION

Groove 1G Fillet

Vertical Progression:

Up Down

TECHNIQUE

Bead Type:

Stringer Weave

Multi Pass

Single Pass

Stick Out 1/2" - 1"

Interpass Cleaning Chip and wire brush.

POSTWELD HEAT TREATMENT

Temp. N/A

Time. N/A

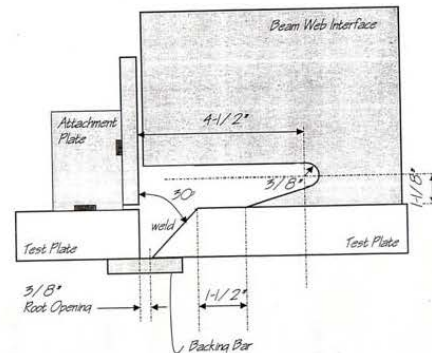

WELDING PROCEDURE

PASS OR LAYERS

All

WIRE SPEED in/min

230-290 ipm

AMPS.

340-380

PROCESS

FCAW-S

VOLTAGE

23-25

FILLER METALS

E71T-8 (ESAB Core Shield 8)
.072"

TRAVEL SPEED

12-20 ipm

CURRENT

DCEN

JOINT DETAILS

B-U4a-GF



SAMPLE WELDER QUALIFICATION PROCEDURE

Seismic Restricted Access Supplemental Welder Qualification Removable Backing

PREQUALIFIED
Yes X No _____

WABO WPS # 102-6

Supporting PQR # prequalified

JOINT DESIGN USED

Type: Butt- Bevel Groove
Single X Double _____

Backing: Yes X No _____

Material Type Ceramic / Copper

Root Opening 3/8 Root Face N/A

Groove Angle 30° Radius J-U N/A

Back Gouging: Yes X No _____

Method CAC-A

BASE METALS

Material Spec. Group I

Type or Grade A36 / A572 grd 50

Thickness: _____

Groove 1" Fillet _____

Diameter (Pipe) _____

FILLER METALS

AWS Specification AWS A5.20

AWS Classification E71T-6

SHIELDING

Gas Type N/A

Flow Rate N/A

Gas Nozzle Size N/A

PREHEAT

Preheat Temp., Min 50°F Max _____

Interpass Temp., Min 50°F Max _____

POSITION

Groove 1G Fillet _____

Vertical Progression: _____

Up _____ Down _____

TECHNIQUE

Bead Type:

Stringer X Weave _____

Multi Pass X

Single Pass _____

Stick Out 1"

Interpass Cleaning Chip and wire brush.

POSTWELD HEAT TREATMENT

Temp. N/A

Time. N/A

BACK-BEAD Back-bead must be welded

Process change OK in the overhead position.

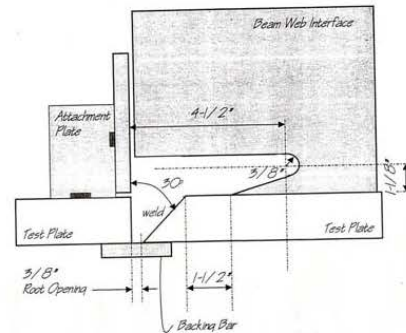

WELDING PROCEDURE

PASS OR LAYERS All **WIRE SPEED in/min** 200-400 **AMPS.** 275-475

PROCESS FCAW-S **VOLTAGE** 23-27

FILLER METALS E71T-6 **TRAVEL SPEED** 15-30
5/64"

CURRENT DCEP **JOINT DETAILS** B-U4a-GF



SAMPLE WELDER QUALIFICATION PROCEDURE

Seismic Restricted Access Supplemental Welder Qualification Removable Backing

PREQUALIFIED		WABO WPS #	102-8
Yes <input checked="" type="checkbox"/> No <input type="checkbox"/>		Supporting PQR #	prequalified
JOINT DESIGN USED			
Type:	Butt- Bevel Groove	Groove	1G
Single	<input checked="" type="checkbox"/> Double <input type="checkbox"/>	Fillet	<input type="checkbox"/>
Backings: Yes <input checked="" type="checkbox"/> No <input type="checkbox"/>			
Material Type	Ceramic / Copper		
Root Opening	3/8" Root Face	N/A	
Groove Angle	30° Radius J-U	N/A	
Back Gouging: Yes:	<input checked="" type="checkbox"/> No <input type="checkbox"/>		
Method	CAC-A		
BASE METALS			
Material Spec.	Group I		
Type or Grade	A36 / A572 grd 50		
Thickness:			
Groove	1" Fillet <input type="checkbox"/>		
Diameter (Pipe)			
FILLER METALS			
AWS Specification	AWS A5.20		
AWS Classification	E71T-8 (ESAB Core Shield 8)		
SHIELDING			
Gas Type	N/A		
Flow Rate	N/A		
Gas Nozzle Size	N/A		
PREHEAT			
Preheat Temp., Min	50°F	Max	<input type="checkbox"/>
Interpass Temp., Min	50°F	Max	<input type="checkbox"/>
TECHNIQUE			
POSITION			
Vertical Progression:			
Up <input type="checkbox"/>		Down <input type="checkbox"/>	
TECHNIQUE			
Bead Type:			
Stringer <input checked="" type="checkbox"/>		Weave <input type="checkbox"/>	
Multi Pass <input checked="" type="checkbox"/>			
Single Pass <input type="checkbox"/>			
Stick Out <u>1/2-1"</u>			
Interpass Cleaning <u>Chip and wire brush.</u>			
POSTWELD HEAT TREATMENT			
Temp.	N/A		
Time.	N/A		
BACK-BEAD Back-bead must be welded			
Process change OK	in the overhead position.		

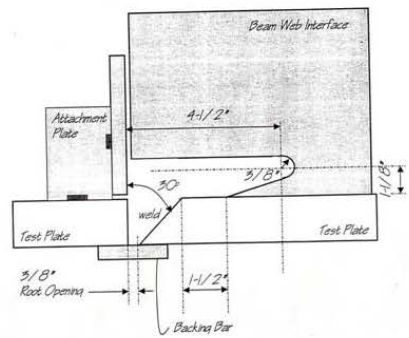

WELDING PROCEDURE

PASS OR LAYERS	WIRE SPEED in/min	AMPS.
All	230-290 ipm	340-380
PROCESS	VOLTAGE	
FCAW-S	23-25	
FILLER METALS	TRAVEL SPEED	
E71T-8 (ESAB Core Shield 8) .072"	12-20 ipm	
CURRENT	JOINT DETAILS	
DCEN	B-U4a-GF	