

DSPTM

HITCHES

www.dsphitches.com

EST. 1961

2011

Catalogue and Hitch Application Book

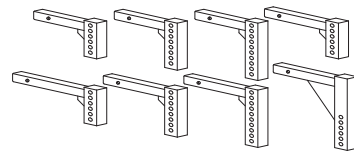
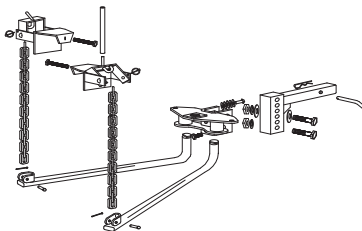
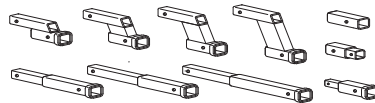
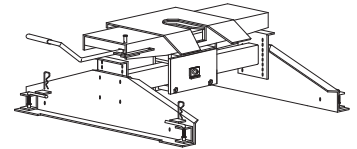
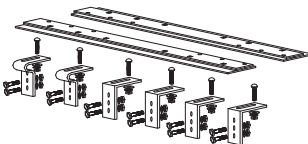
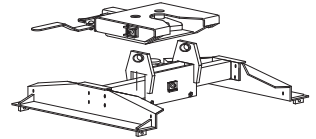
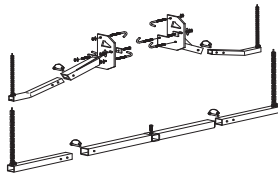
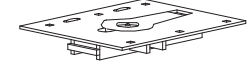
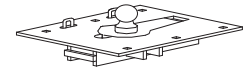
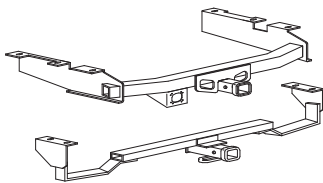
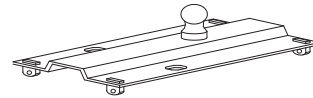
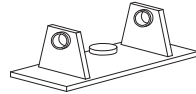
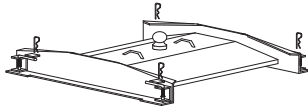
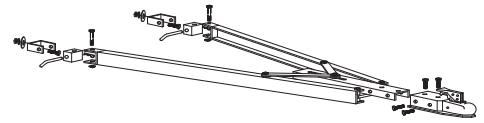
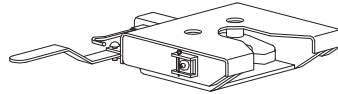
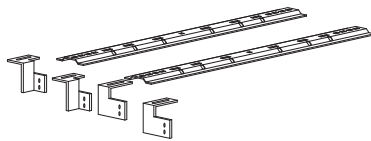

PROUDLY CANADIAN OWNED & OPERATED

Products manufactured and assembled in Canada

Thank you for supporting DSP and your North American communities

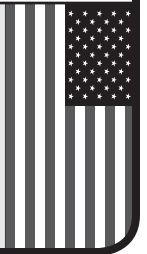

Over 50 new products

Weight Distribution System

New v-nose clamp
call for more details

Ballmounts

16" length; see page 4

Bolt on Receivers:

Truck body 14/15K
page 10

Camper Tiedown

See pages 11 – 12

Application

page 13

Camper Yard Jack

page 14

Camper Steps

page 14

Receiver extension

Solid shaft
page 14

Gooseneck

Crossbed 26K
Folding Hide-Away Hitchball
page 24

Fifth Wheel Mounting Kit

page 25

Motorhome Adaptors

Solid 10K
page 27

Fit Applications DP Series

See page 25

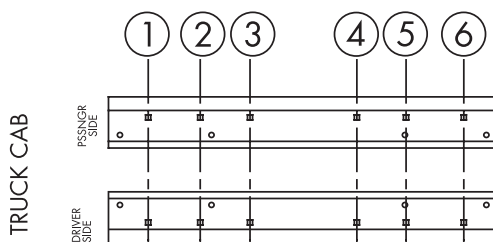

X Series

See page 26

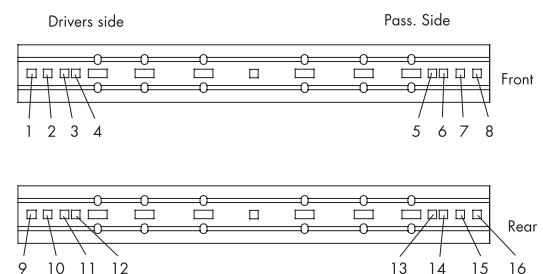

CONTENTS

Ballmounts and Hitchballs

Ballmounts	4
Specialty Ballmounts	5
Adjustable Shanks	2
Hitchballs	4

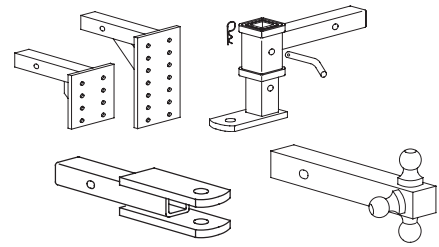

Bolt On Hitch Receivers

Ratings and General Information	6
Listings by Vehicle Make and Model	7 – 10
Listings by Item Number	39 – 44
Receiver Adapters/Reducer Sleeves	3
Towbar Adapters	3

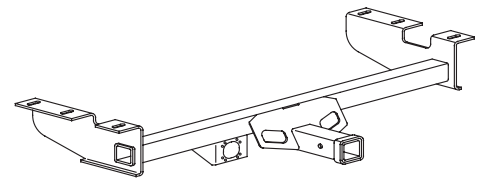

Camper Products

Camper Tiedowns — Complete Kits (Drawings)	11 – 12
Camper Tiedown Fit List	13
Camper Steps	4
Receiver Extensions	3
Camper Yard Jacks	14

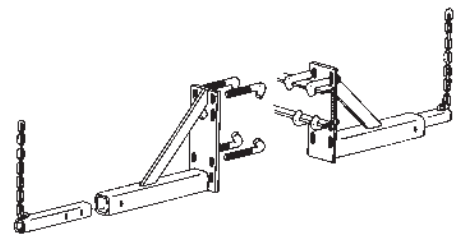

Fifth Wheel and Gooseneck Trailer Hitches

Fifth Wheel Hitches	15
Dual Position Sliding Original & Easy Level —	
Double Tilt	17
Cross Bed (Original and Double Tilt Application)	18
Falcon Light Commercial	19 – 23
Fifth Wheel Hitches (Rail Kits)	
Dual Position Installation	25
Cross Bed Original & Double Tilt Application	26
Fifth Wheel Hitches (Parts & Accessories)	35 – 36
Fifth Wheel Hitch General Information	37 – 38
Gooseneck Fifth Wheel Hitches	24
King Pins & Gooseneck Hitchballs Parts & Accessories	36

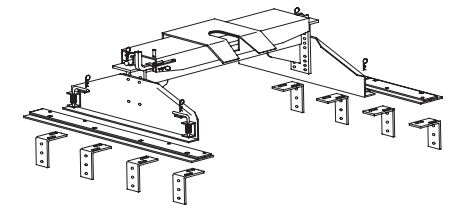

Motorhome Products/Truck Body

Receiver Extensions	10
Towbar Adapters	3
Towbars	29

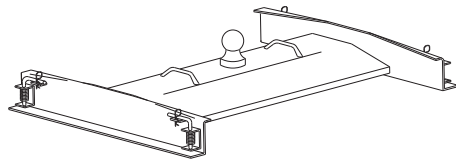

Weight Distribution Systems

Weight Distribution Systems — Complete Kits	1
Weight Distribution System Replacement Packs	33
Weight Distribution System Parts & Accessories	31 – 32
Dust Caps	3
Single Pole Tongue Adapter	2

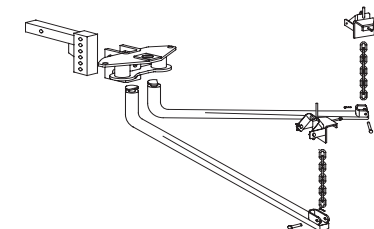

Polar Sled Lock

Numerical Product Listings	46 – 48
Freight and Return Policy	51
Warranty Policy & Return Procedure	52

DSP Weight Distribution System Kits

- once assembled, no tools are required to connect or disconnect
- distributes weight to all trailer and towing vehicle axles
- increases steering capability, brake control and towing safety
- reduces sway from traffic and sudden crosswinds
- all systems must be used with a Bolt On Hitch Receiver rated for the same T.W. & G.T.W.
- no left & right torsion bars, both are interchangeable
- torsion bars must always be used to achieve T.W. & G.T.W.
- five Tongue Weight (T.W.) capacities to choose from: ranging from 350 – 1,200 lbs

**Since
1961**

DSP Classic Weight Distribution System

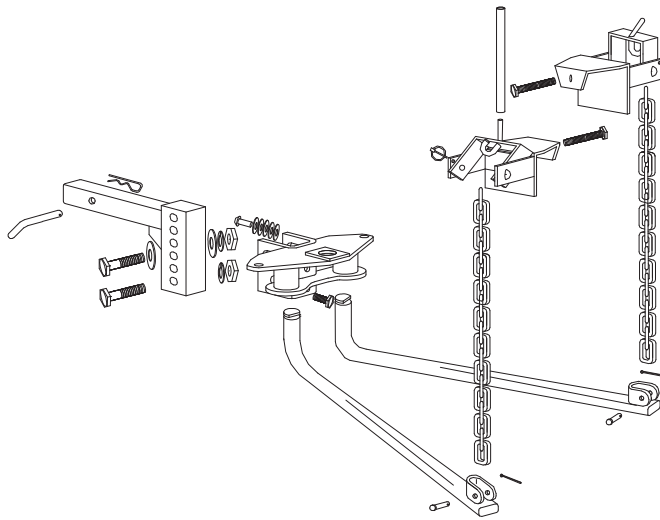

Item #	T.W.	G.T.W.	Retail
41653	400 lbs	4,000 lbs	
41654	600 lbs	6,000 lbs	
41655	800 lbs	8,000 lbs	
41656	1,000 lbs	10,000 lbs	
41657	1,200 lbs	12,000 lbs	

- Shank #43201 included with Weight Distribution System Kits. Upgrade to greater drop or length available on request. Upgrade charges will apply. See price list under shanks (WDS)
- All kits supplied with the DSP clamps
- Dual integrated sway control brackets for usage of sway control bracket systems on the passenger and/or driver's side, provides the option of using more than one sway control with large trailers

Now available V-nose clamps, with weight distribution special order

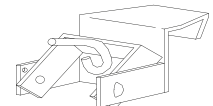

DSP Trunnion Style Weight Distributions Systems

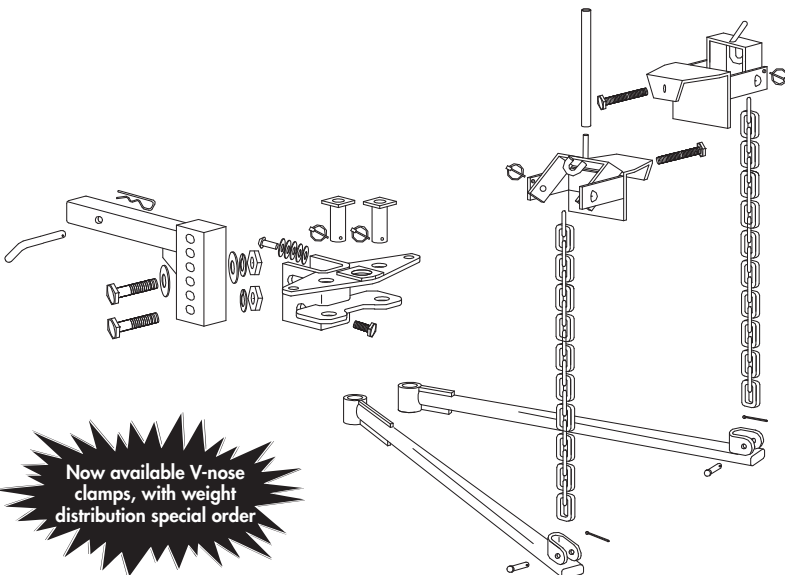

Item #	T.W.	G.T.W.	Retail
42153	400 lbs	4,000 lbs	
42154	600 lbs	6,000 lbs	
42155	800 lbs	8,000 lbs	
42156	1,000 lbs	10,000 lbs	

- Gives more ground clearance for combinations of vehicles and/or trailers with limited suspensions
- Gives more ground clearance while traveling on rough terrain
- Dual integrated sway control brackets for usage of sway control bracket systems on the passenger and/or driver's side, provides the option of using more than one sway control with large trailers
- All kits supplied with the DSP clamps
- Shank #43201 included with Weight Distribution System Kits. Upgrade to greater drop or length available on request. Upgrade charges will apply. See price list under shanks (WDS)

Now available V-nose clamps, with weight distribution special order

Adjustable Shanks	Item #	Drop (G)	Rise (E)	Length (F)	Holes	Receiver Size	Retail
	43201	2"	7"	10"	6	2" x 2"	
	43202	4"	9.5"	10"	8	2" x 2"	
	43203	7"	12.5"	10"	10	2" x 2"	
	43204	2"	7"	12"	6	2" x 2"	
	43205	2"	7"	14"	6	2" x 2"	
	43206	4"	9.5"	12"	8	2" x 2"	
	43207	7"	12"	12"	10	2" x 2"	
	43208	10"	15"	12"	6 DD	2" x 2"	
	43209	4"	9.5"	14"	8	2" x 2"	
	43210	2"	7"	16"	6	2" x 2"	
	43211	13"	18"	14"	6 XD	2" x 2"	

— Shank #43201 included with Weight Distribution System Kits. Upgrade to greater drop or length available on request. Upgrade charges will apply. See price list under shanks (WDS)

DD — Deep Drop equivalent to 12 hole.

XD — Extra Deep Drop equivalent to 14 hole.

All shanks rated for 12,000 lbs.

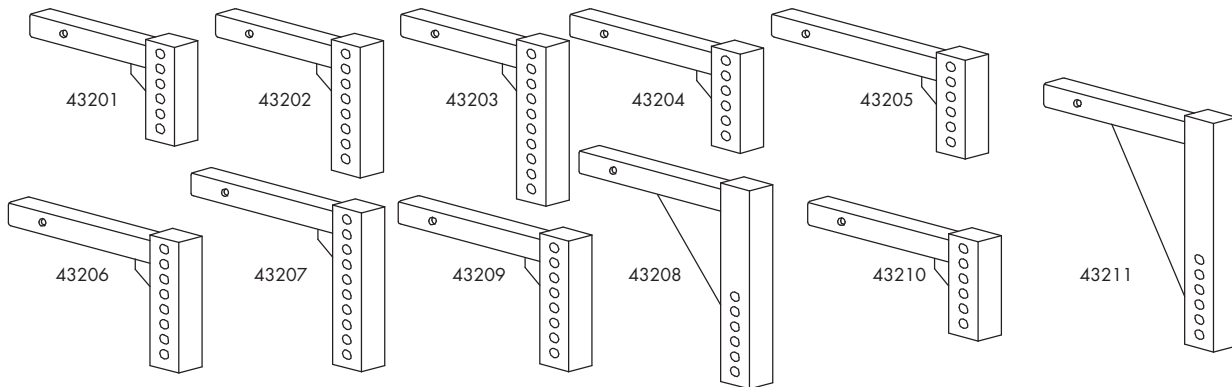

Single Pole Tongue Adapter (for Weight Distribution Systems)	Item #	Description	Ship Wgt	Retail
	43811	Adjusts 2" x 2" to 5" x 5" tube or channel frames	23.5 lbs	

— For use on trailers with single tongues that require a Weight Distribution System

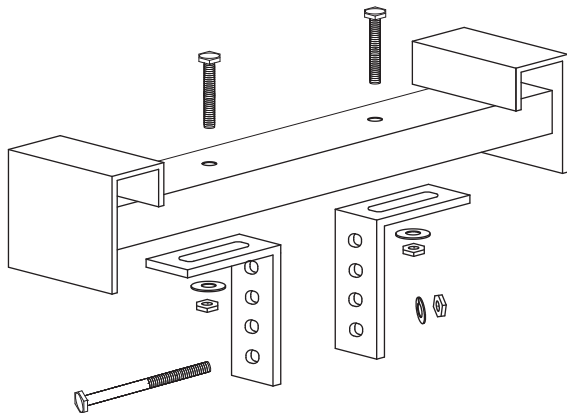

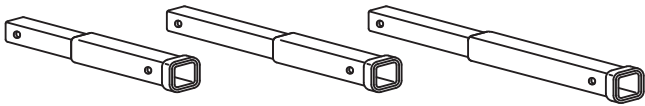
Receiver Hitch Extensions	Item #	Description	Extends	Ship Wgt	Retail
	43371	2" x 2" (T)	7"	6.4	
	43372	2" x 2" (T)	10"	8.4	
	43373	2" x 2" (T)	14"	10.0	
	43374	2" x 2" (T)	18"	12.2	
	NEW 43376	2" x 2" (S)	7"		
	NEW 43377	2" x 2" (S)	10"		
	NEW 43378	2" x 2" (S)	14"		
	NEW 43379	2" x 2" (S)	18"		
	- intended to extend receivers with overhanging campers Note: will reduce WC and WD up to 50%				

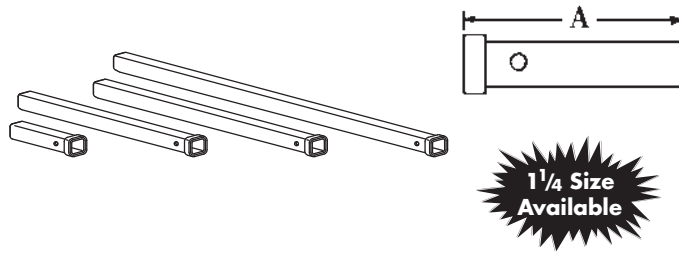
Sleeves	Item #	Length (A)	Receiver Size	Ship Wgt	Retail
	43301	10"	2" x 2"	6.0	
	43302	36"	2" x 2"	20.4	
	43303	48"	2" x 2"	26.8	
	43304	24"	2" x 2"	13.6	
	43305	6"	2" x 2"		
	43311	6"	1 1/4" x 1 1/4"	1.8	
	43312	10"	1 1/4" x 1 1/4"	2.6	

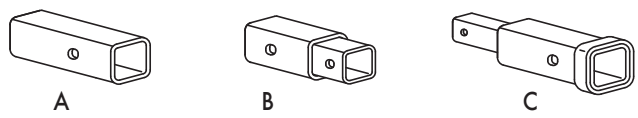
Receiver Adapters	Item #	Description	Ship Wgt	Retail
	43331	(A) Reducer, reduces 2 1/2 to 2"	2.6	
	43332	(A) Reducer, reduces 1 5/8" to 1 1/4"	4.0	
	43333	(B) Reducer, reduces 2" to 1 1/4"	3.2	
	43361	(C) Increaser, increases 1 1/4" to 2"	7.2	
Helps to reduce/increase larger/smaller receivers to accommodate accessories				

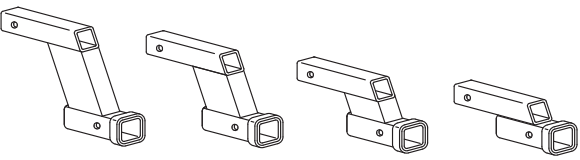
Towbar Adapters	Item #	Description	Rating	Ship Wgt	Retail
	43381	Drop: 2" Receiver: 2" x 2" (T)	6K	7.6	
	43382	Drop: 4" Receiver: 2" x 2" (T)	6K	8.8	
	43383	Drop: 6" Receiver: 2" x 2" (T)	6K	9.5	
	43384	Drop: 8" Receiver: 2" x 2" (T)	6K	11.00	
	NEW 43386	Drop: 2" Length: 13" (S)	10K		
	NEW 43387	Drop: 4" Length: 13" (S)	10K		
	NEW 43388	Drop: 6" Length: 13" (S)	10K		
	NEW 43389	Drop: 8" Length: 13" (S)	10K		
Tube = T Solid = S					

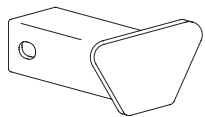
Dust Caps	Item #	Receiver Size	Ship Wgt	Retail
	43781 ☼	1 1/4" x 1 1/4"	.07	

☼ while supplies last

CNC Machined Hitchballs		Item #	Finish	HSD (N)	TL	G.T.W.	Thread
<p>Now Available Chrome Plated</p> <p>Larger Variety Available</p>		Ball Size (B) 1 7/8"					
		11147	Chrome	1"	2"	3,500	External
		11148	Chrome	3/4"	1 3/4"	2,000	Internal
		11151	Chrome	3/4"	1 1/2"	2,000	External
		Ball Size (B) 2"					
		11149	Chrome	3/4"	1 3/4"	3,500	Internal
		11152	Chrome	3/4"	1 1/2"	3,500	External
		11258	Chrome	1 1/4"	2 1/4"	8,000	External
		48501	Paint	3/4"	1 3/4"	6,000	External
		48602	Paint	1"	1 3/4"	6,000	External
		48604	Paint	1 1/4"	1 3/4"	7,500	External
		Ball Size (B) 2 5/16"					
		48603	Paint	1"	1 3/4"	7,500	External
		11154	Chrome	1"	2"	5,000	External
		11155	Chrome	1 1/4"	2"	7,500	External
		11259	Chrome	1 1/4"	Standard	30,000	External
		11261	Chrome	1 1/4"	2"	30,000	External
		11155H	Chrome	1 1/4"	2"	10,000	External
11155X	Chrome	1 1/4"	2"	12,000	External		
Ballmounts		Item #	Style	Rise/Drop (A)	Length (B)	Receiver Size	Retail
<p>NEW 16" LENGTH</p> <p>NEW 16" LENGTH</p> <p>NEW 16" LENGTH</p> <p>New 10,000 lb Capacity Available</p>		Ratings: T.W. 350 lbs/159 kg (HSD = 3/4") G.T.W. 3,500 lbs/1,590 kg					
		49233	i	3	10	1 5/8 x 1 5/8	
		49234	i	3	8	1 5/8 x 1 5/8	
		49311	ii	1	7	1 1/4 x 1 1/4	
		49312	ii	1	9.5	1 1/4 x 1 1/4	
		49331	i	3	7.5	1 1/4 x 1 1/4	
		49342	no pic	4	10	1 1/4 x 1 1/4	
		49343	no pic	4	11	1 1/4 x 1 1/4	
		49352	no pic	5	10	1 1/4 x 1 1/4	
		49361	i	6	8	1 1/4 x 1 1/4	
		Ratings: T.W. 600 lbs/272 kg (HSD = 1") G.T.W. 6,000 lbs/2,727 kg					
		49523	ii	2"	8"	2" x 2"	
		49524	ii	2"	10"	2" x 2"	
		49532	i	3"	10"	2" x 2"	
		49542	i	4"	10"	2" x 2"	
		49546	ii	4"	16"	2" x 2"	
		49562	i	6"	10"	2" x 2"	
		49566	ii	6"	16"	2" x 2"	
		49582	i	8"	10"	2" x 2"	
		49592	i	10"	8"	2" x 2"	
49621	iii	2"	8"	2" x 2"			
49622	iii	2"	10"	2" x 2"			
49626	iii	2"	16"	2" x 2"			
49642	iii	4"	10"	2" x 2"			
49662	iii	6"	10"	2" x 2"			
49682	iii	8"	8"	2" x 2"			
Ratings: T.W. 800 lbs/363 kg (HSD = 1 1/4") G.T.W. 8,000 lbs/3,636 kg (Solid Shank)							
49842	i	4"	10"	2" x 2" (s)			
49882	i	8"	10"	2" x 2" (s)			
Ratings: T.W. 1,000 lbs/454 kg (HSD = 1 1/4") G.T.W. 10,000 lbs/4,545 kg (Solid Shank)							
49922	ii	2"	10"	2" x 2" (s)			
49942	i	4"	10"	2" x 2" (s)			
49962	i	6"	10"	2" x 2" (s)			
49982	i	8"	10"	2" x 2" (s)			

HSD - Hitchball Shank Diameter

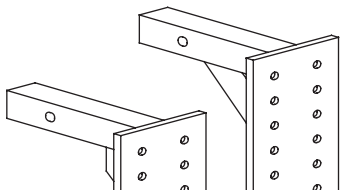
Pintle Hook Adapter Mounts	Item #	Shank Length	Hole Settings	Ratings		Retail
				T.W.	G.T.W.	
	47132	10"	4	1,000 lbs 454 kg	10,000 lbs 4,545 kg	
	47133	12"	4	1,000 lbs 454 kg	10,000 lbs 4,545 kg	
	47134	12"	7	1,000 lbs 454 kg	10,000 lbs 4,545 kg	

Note: Face plate thickness 5/8", width 6", hole diameter 17/32", hole separation vertical 1-3/4", horizontal 3-1/2"
Warning: Must be used with Bolt On Hitch Receiver with an adequate W.C.

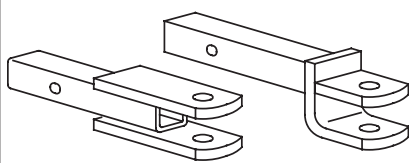
Clevis Ballmounts (2" x 2" tubing)	Item #	Hitchball Shank Dia.	Length	Rise/Drop	As Clevis		As Ballmount		Retail
					T.W.	G.T.W.	T.W.	G.T.W.	
	47211	1"	10"	1" Straight	600 lbs 272 kg	6,000 lbs 2,727 kg	600 lbs 272 kg	6,000 lbs 2,727 kg	
	47212	1"	10"	1" Straight	800 lbs 363 kg	8,000 lbs 3,636 kg	600 lbs 272 kg	6,000 lbs 2,727 kg	
	47223	1"	10"	2" Drop	600 lbs 272 kg	6,000 lbs 2,727 kg	600 lbs 272 kg	6,000 lbs 2,727 kg	
	47291	Pin & Clip for Clevis Ballmounts							

Warning: Must be used with Bolt On Hitch Receiver with an adequate W.C.
Note: Pin & Clip not included with Ballmount

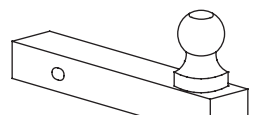
Multi-Ball (2) Ballmounts (2" x 2" solid shank)	Item #	Hitchball Dia.	Hitchball Dia.	Length	T.W.	G.T.W.	Retail
	47421 ⚠	1-7/8"	2"	10"		See Note Below	
	Not Available	2"	2-5/16"	10"			

Note: Hitchball G.T.W. Rating: 1-7/8" = 2,000 lbs, 2" and 2-5/16" = 6,000 lbs

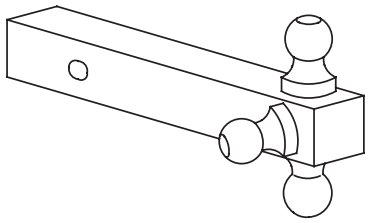
Multi-Ball (3) Ballmounts (2" x 2" solid shank)	Item #	Hitchball Diameters			Length	T.W.	G.T.W.	Retail
	47501	1-7/8"	2"	2-5/16"	10"	See Note Below		

Note: Hitchball G.T.W. Rating: 1-7/8" = 2,000 lbs, 2" and 2-5/16" = 6,000 lbs

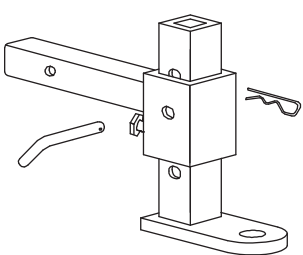
Adjustable Ballmounts (2" x 2" tubing)	Item #	Length	T.W.	G.T.W.	Retail
	47601	10"	600 lbs 272 kg	6,000 lbs 2,727 kg	

- Universal for 2" x 2" Receivers
- 4 rise and drop settings: 4", 6-1/2", 8-1/2" and 10"
- Rattle reducing Set Screw

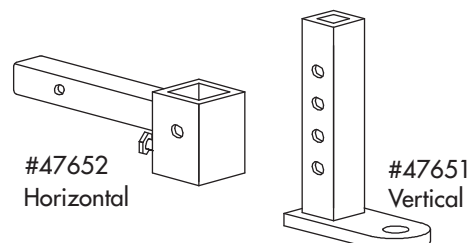

Replacement Parts	
47651	Vertical replacement
47652	Horizontal Shank replacement

⚠ while supplies last

DSP Bolt On Hitch Receivers (General Information)

DSP currently manufactures over 50 Bolt On Hitch Receivers.

Front Mount: Great for backing up RV and boats; for use with winch mounts and many other options.

Class II: Built for smaller towing vehicles, towing light trailers or bicycle racks.

Class III: Built for mid and fullsize vehicles, towing heavier loads using Weight Distribution Systems.

Class III Contoured: Same application as the regular Class III receivers with an extra attractive style.

Class IV: Built for heavier trailers, for towing vehicles with heavier load towing capability.

Class II Receiver Hitch

Bolts included

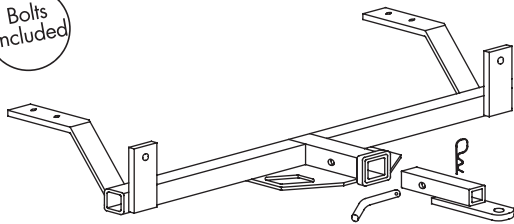

Series	Receiver	G.T.W.	T.W.	Ballmount
52000	1-5/8" x 1-5/8"	3,500 lbs 1,590 kg	350 lbs 159 kg	1-5/8" x 1-5/8" included
53000	1-1/4" x 1-1/4"	3,500 lbs 1,590 kg	350 lbs 159 kg	1-1/4" x 1-1/4" included
54000	2" x 2"	3,500 lbs 1,590 kg	350 lbs 159 kg	not included

Warning: Class II Receivers are not intended to be used with Weight Distribution Systems.

Class III and IV Receiver Hitch; 2" x 2"

Bolts included

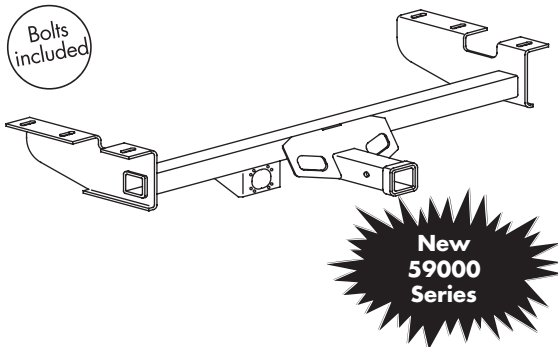

Series	Weight Distribution System (WD)*		Weight Carrying with Ballmount	
	G.T.W.	T.W.	G.T.W.	T.W.
55000	5,000 lbs 2,272 kg	500 lbs 227 kg	3,500 lbs 1,590 kg	350 lbs 159 kg
56000	8,000 lbs 3,636 kg	800 lbs 363 kg	5,000 lbs 2,272 kg	500 lbs 227 kg
57000	10,000 lbs 4,545 kg	1,000 lbs 454 kg	6,000 lbs 2,727 kg	600 lbs 272 kg
58000	12,000 lbs 5,454 kg	1,200 lbs 545 kg	8,000 lbs 3,636 kg	800 lbs 363 kg
59000	14,000 lbs 6,350 kg	1,400 lbs 635 kg	12,000 lbs 5,454 kg	1,200 lbs 545 kg

Crossmember Mounted "Stubbie"

Crossmember mounted BOR are not fullsize receivers. Installs directly to the crossmember located behind the bumper for an easier installation.

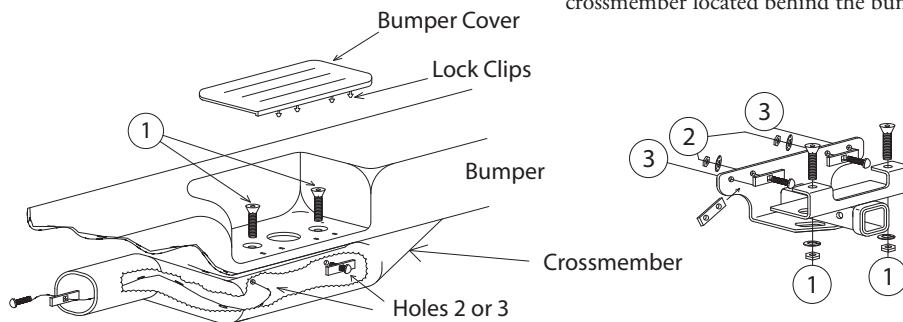

***Warning:** To achieve the higher rating, a Weight Distribution System must be used at all times. For Weight Distribution Systems see Page 1.

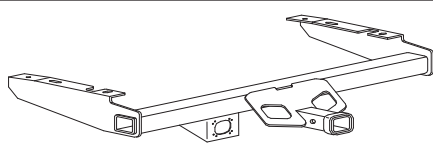

Frame Mounted Receiver

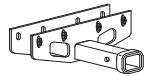

"Stubbie"
 Crossmember
 Mounted Receiver

Ratings Series	Receiver Size	Weight Distribution		Carrying Weight	
		G.T.W.	T.W.	G.T.W.	T.W.
54000	2x2	3,500 lbs	350 lbs	3,500 lbs	350 lbs
55000	2x2	5,000 lbs	500 lbs	3,500 lbs	350 lbs
56000	2x2	8,000 lbs	800 lbs	5,000 lbs	500 lbs
57000	2x2	10,000 lbs	1,000 lbs	6,000 lbs	600 lbs
58000	2x2	12,000 lbs	1,200 lbs	10,000 lbs	1,000 lbs
59000	2x2	14,000 lbs	1,400 lbs	12,000 lbs	1,200 lbs

Buick/Cadillac			Frame	Year	PCS	Drill	Receiver	Rating	Part #
Van	Buick Terraza	includes AWD	33"	2005-2007	1 pcs	no	2x2	3.5K	54354
SUV	Cadillac Escalade	includes Ext & Esv	39"	2003-2006	1 pcs	no	2x2	6/10K	57474 ☞
Chev/GMC			Frame	Year	PCS	Drill	Receiver	Rating	Part #
SUV	Equinox		43"	2004-2011	1 pcs	no	2x2	3.5K	54476
	Avalanche/ Tahoe/ Yukon (inc.XL)		39"	2001-2006	1 pcs	no	2x2	6/10K	57474 ☞
	Blazer S10/Jimmy S15 (Olds Bravada 1991-1999)		38"	1984-1991	1 pcs	no	2x2	5/8K	56452 ☞
	Suburban & Tahoe/ Yukon	old body	34"	1992-1999	1 pcs	no	2x2	5/8K	56473 ☞
		new body incXL	39"	2000-2006	1 pcs	no	2x2	6/10K	57474 ☞
	GMC Terrain		43"	2010-2011	1 pcs	no	2x2	3.5K	54476
Vans	Astro/ Safari	regular & extended (exposed crossbar)	38"	1985-1995	3 pcs	no	2x2	5/8K	56352 ☞
	Venture		33"	1997-2009	1 pcs	no	2x2	3.5K	54354
	Lumina Apv		33"	1990-1993	1 pcs	no	1 5/8 x 15/8	3.5K	52351 ☞
	Uplander	includes AWD	33"	2005-2011	1 pcs	no	2x2	3.5K	54354
	Full-size Chev Express/Gmc Savanna			43"	1978-1995	1 pcs	no	2x2	6/10K
			56.5"	1996-2011	1 pcs	no	2x2	6/10K	57372
Trucks	Sierra/ Silverado	New generation 1500 Light Duty	39"	2007-2011	1 pcs	no	2x2	6/10K	57432
		Heavy Duty 2500, 3500	38.5"	2001-2011	1 pcs	no	2x2	12/14K	59431
		Classic body style	39"	1999-2007	1 pcs	no	2x2	6/10K	57428
		pre 1998	35.5"	1988-1998	1 pcs	no	2x2	6/10K	57426
		long box only	39"	1988-1998	1 pcs	no	2x2	6/10K	57701 ☞
		short & long box		1973-1987	3 pcs	no	2x2	5/8K	56425
		long box only	34"	1962-1987	1 pcs	yes	2x2	12/14K	59431
	Cab & Chassis		34"	1988-2011	1 pcs	yes	2x2	12/14K	59431
	S10 & S15, Sonoma		40.75"	1983-2004	1 pcs	no	2x2	3.5/5K	55403 ☞
	Colorado/ Canyon		48"	2004-2007	1 pcs	no	2x2	3.5/5K	55407 ☞
			48"	2008-2011	1 pcs	no	2x2	3.5/5K	
Dodge/Chrysler			Frame	Year	PCS	Drill	Receiver	Rating	Part #
Car	Intrepid		37.5"	1998-2004	1 pcs	no	1 1/4 x 1 1/4	3.5K	53501 ☞
Van	Chrysler Town & Country, Caravan (+ Voyager 01-04)		37"	1996-2006	1 pcs	no	2x2	3.5/5K	55552
			56.5"	2005-2007	1 pcs	no	2x2	3.5/5K	N/A
			53"	2008-2011	1 pcs	no	2x2	3.5/5K	55554
	Dodge Caravan	except stow and go	37"	1996-2004	1 pcs	no	2x2	3.5/5K	55552
	Dodge Grand Caravan	except stow and go	37"	2005-2006	1 pcs	no	2x2	3.5/5K	55552
		stow and go only	56.5"	2005-2007	1 pcs	no	2x2	3.5/5K	N/A
		stow and go only	53"	2008-2011	1 pcs	no	2x2	3.5/5K	55554
	Full-size Van		43"	1971-2004	1 pcs	no	2x2	6/10K	57526 ☞
Trucks	Ram 1500 Full-size	2002-2008 use 57631	stubbie	2009-2011	1 pcs	no	2x2	6/10K	57632
	Ram 2500 & 3500 Full-size	built after 11/01/02	stubbie	2003-2011	1 pcs	no	2x2	6/10K	57631
	Ram Full-size	inc. 2500 & 3500 2002	36"	1994-2001	1 pcs	yes	2x2	6/10K	57626 ☞
		inc. 2500 & 3500 2002	35"	1994-2001	1 pcs	no	2x2	6/10K	57629 ☞
	Ram	pre-1993	36/40"	1973-1993	3 pcs	yes	2x2	6/10K	57702 ☞
	Dakota	inc. Extended body	35.5"	1987-2004	1 pcs	no	2x2	5/8K	56604
		Stubbie	2005-2011	1 pcs	no	2x2	5/5K	55605 ☞	
			39"	2005-2011	1 pcs	no	2x2	5/8K	56605

Notes

☞ While supplies last. Clearance price available.



HITCHES

www.dsphitches.com
EST.1961

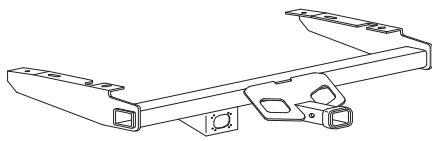

Frame Mounted Receiver

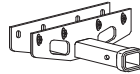

"Stubbie"
Crossmember
Mounted Receiver

Series	Receiver Size	Weight Distribution		Carrying Weight	
		G.T.W.	T.W.	G.T.W.	T.W.
54000	2x2	3,500 lbs	350 lbs	3,500 lbs	350 lbs
55000	2x2	5,000 lbs	500 lbs	3,500 lbs	350 lbs
56000	2x2	8,000 lbs	800 lbs	5,000 lbs	500 lbs
57000	2x2	10,000 lbs	1,000 lbs	6,000 lbs	600 lbs
58000	2x2	12,000 lbs	1,200 lbs	10,000 lbs	1,000 lbs
59000	2x2	14,000 lbs	1,400 lbs	12,000 lbs	1,200 lbs

Ford	Frame	Year	PCS	Drill	Receiver	Rating	Part #
SUV	Escape including hybrid	40"	2001-2004	1 pcs	no	2x2	3.5K 54282
	<i>Note: No cutting of plastic bumper</i>	40"	2005-2011	1 pcs	no	2x2	3.5K 54283
	Explorer	37"	1991-1997	1 pcs	no	2x2	3.5/5K 55275 ☒
		47"	1998-2001	1 pcs	no	2x2	3.5/5K 55976 ☒
	Ford Expedition	47"	1997-2002	1 pcs	no	2x2	6/10K 57281 ☒
	Bronco (fullsize)	36/40"	1980-1996	3 pcs	no	2x2	3.5K 57702 ☒
Bronco II (downsize)	n/a	1983-1990	1 pcs	no	2x2	3.5K 55251 ☒	
Vans	Aerostar extended only		1989-1998	3 pcs	no	2x2	3.5K 52152 ☒
	Windstar (Mini-van)	37"	1995-2003	1 pcs	no	2x2	3.5/5K 55151
	Econoline (Full-size) step bumper	38.5"	1992-2009	1 pcs	no	2x2	6/10K 57178
Trucks	F-150	34"	2009-2011	1 pcs	no	2x2	6/10K 57234
		inc. 2007-2008 Mark LT	29"	2006-2008	1 pcs	no	2x2 6/10K 57233
			36.5"	2004-2005	1 pcs	yes	2x2 6/10K 57230 ☒
	F-250, F-350 & Super duty	34.5"	1999-2011	1 pcs	no	2x2	6/10K 57232
			39.5	1999-2011	1 pcs	no	2x2 12/14K 59229
	F-150 & F-250	Light Duty only will not fit Heavy Duty	33.5"	1997-2003	1 pcs	no	2x2 6/10K 57226
	F-series	inc. 1997-1998 F-250,350 Heavy Duty pre 1998 pre 1979	35"	1980-1996	1 pcs	no	2x2 6/10K 57225
			39"	1967-1979	1 pcs	no	2x2 6/10K 57701 ☒
	Cab & Chassis	34"	1999-2011	1 pcs	no	2x2	12/14K 59230
	36/40"	1980-1996	3 pcs	yes	2x2	6/10K 57702 ☒	
Ranger	31"	1983-2010	1 pcs	no	2x2	3.5/5K 55201	

GMC See Chev/GMC

Honda	Frame	Year	PCS	Drill	Receiver	Rating	Part #
Van Honda Odyssey	53"	1999-2011	1 pcs	no	2x2	3.5K/5K	
SUV	Honda CRV	2002-2006	1 pcs	no	2x2	3.5K	54854
		2007-2011	1 pcs	no	2x2	3.5K	
	Honda Pilot (inc. Acura MDX 2001-08)	2003-2008	1 pcs	no	2x2	3.5/5K	
	Honda Element	2003-2011	1 pcs	no	2x2	3.5K	
Truck Honda Ridge Line		2005-2011	1 pcs	no	2x2	5/8K	

Hyundai	Frame	Year	PCS	Drill	Receiver	Rating	Part #
SUV	Hyundai Santa Fe	will not fit 2010	52"	2007-2009	1 pcs	no	2x2 3.5K 54891
				2010-2011	1 pcs	no	2x2 3.5K
	Hyundai Veracruz	53.5"	2007-2011	1 pcs	no	2x2	3.5K 54892
	Hyundai Tucson	will not fit 2010	2005-2009	1 pcs	no	2x2	3.5K
		2010-2011	1 pcs	no	2x2	3.5K	
Van Hyundai Entourage		2007-2009	1 pcs	no	2x2	5/8K 56894	

Kia	Frame	Year	PCS	Drill	Receiver	Rating	Part #
SUV Sportage		2005-2008	1 pcs	no	2x2	3.5K	
Van Sedona (118.4" long wheel base only)		2006-2010	1 pcs	no	2x2	3.5/5K	

Infiniti	Frame	Year	PCS	Drill	Receiver	Rating	Part #
SUV QX4	37"	1997-2003	1 pcs	no	2x2	3.5/5K	55831 ☒

Isuzu	Frame	Year	PCS	Drill	Receiver	Rating	Part #
Truck "I" Series Trucks I350, I280, I290, I370		2006-2008	1 pcs	no	2x2	3.5/5K	55408

Notes

☒ While supplies last. Clearance price available.

Bolt On Hitch Receivers

Ford • GMC • Honda • Hyundai • Kia • Infiniti • Isuzu

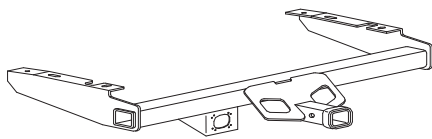

Frame Mounted Receiver

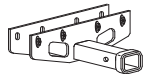

"Stubbie"
 Crossmember
 Mounted Receiver

Series	Receiver Size	Weight Distribution		Carrying Weight	
		G.T.W.	T.W.	G.T.W.	T.W.
54000	2x2	3,500 lbs	350 lbs	3,500 lbs	350 lbs
55000	2x2	5,000 lbs	500 lbs	3,500 lbs	350 lbs
56000	2x2	8,000 lbs	800 lbs	5,000 lbs	500 lbs
57000	2x2	10,000 lbs	1,000 lbs	6,000 lbs	600 lbs
58000	2x2	12,000 lbs	1,200 lbs	10,000 lbs	1,000 lbs
59000	2x2	14,000 lbs	1,400 lbs	12,000 lbs	1,200 lbs

Jeep	Frame	Year	PCS	Drill	Receiver	Rating	Part #		
SUV	Jeep YJ	includes 1987-1996 Wrangler	43"	1987-1996	1 pcs	no	2x2	3.5K	54653 ☒
	TJ & Wrangler	exp. 1991-2002 Renegade	40"	2004-2006	1 pcs	no	2x2	3.5K	54654 ☒
	Wrangler Unlimited		stubbie	2007-2011	1 pcs	no	2x2	3.5K	54655
	Liberty		38"	2000-2007	1 pcs	no	2x2	5/8K	N/A
			38.5"	2008-2011	1 pcs	no	2x2	5/8K	56656
	Cherokee		35"	1984-2001	1 pcs	no	2x2	3.5/5K	55652 ☒
	Grand Cherokee		36"	1993-1998	1 pcs	no	2x2	5/8K	56552 ☒
			n/a	1999-2004	1 pcs	no	2x2	5/8K	56553 ☒
	Grand Wagoneer		36"	1993-1998	1 pcs	no	2x2	5/8K	56552 ☒
	Wagoneer		n/a	1999-2004	1 pcs	no	2x2	5/8K	56553 ☒
Lexus	Frame	Year	PCS	Drill	Receiver	Rating	Part #		
SUV	Lexus RX300	inc. Lexus 350 2007-2009, RX400H 2006-2009	42"	2004-2005	1 pcs	no	2x2	3.5K	54804 ☒
Lincoln	Frame	Year	PCS	Drill	Receiver	Rating	Part #		
SUV	Navigator		47"	1997-2002	1 pcs	no	2x2	6/10K	57281 ☒
Truck	Mark LT		29"	2007-2008	1 pcs	no	2x2	6/10K	57233
Mazda	Frame	Year	PCS	Drill	Receiver	Rating	Part #		
Truck	Mazda B Series		31"	2006-2008	1 pcs	no	2x2	3.5/5K	55201
SUV	Mazda Tribute		40"	2001-2004	1 pcs	no	2x2	3.5K	54282
		<i>Note: No cutting of Plastic Bumper</i>	40"	2005-2011	1 pcs	no	2x2	3.5K	54283
Mercury	Frame	Year	PCS	Drill	Receiver	Rating	Part #		
SUV	Mountaineer		37"	1991-1997	1 pcs	no	2x2	3.5/5K	55275 ☒
			47"	1998-2001	1 pcs	no	2x2	3.5/5K	55976 ☒
	Mariner	<i>Note: No cutting of Plastic Bumper</i>	40"	2005-2009	1 pcs	no	2x2	3.5K	54283
Car	Sable		37.5"	1986-2004	1 pcs	no	1 1/4x 1 1/4	3.5K	53501 ☒
Mitsubishi	Frame	Year	PCS	Drill	Receiver	Rating	Part #		
Truck	Raider		39"	2005-2008	1 pcs	no	2x2	3.5/5K	55605 ☒
Nissan	Frame	Year	PCS	Drill	Receiver	Rating	Part #		
SUV	Nissan Pathfinder 2 & 4 Door	inc. 97-03 Infinity QX4	37"	1996-2004	1 pcs	no	2x2	3.5/5K	55831 ☒
Trucks	Nissan Titan		44"	2004-2009	1 pcs	no	2x2	6/10K	
	Nissan Frontier		35"	2005-2011	1 pcs	no	2x2	3.5/5K	56832
Oldsmobile	Frame	Year	PCS	Drill	Receiver	Rating	Part #		
Van	Silhouette	120" wheel base only	33"	1990-1993	1 pcs	no	1 1/4x 1 1/4	3.5K	52351 ☒
			33"	1997-2004	1 pcs	no	2x2	3.5K	54354
Plymouth	Frame	Year	PCS	Drill	Receiver	Rating	Part #		
Van	Voyager & Grand Voyager	except stow and go	37"	1996-2004	1 pcs	no	2x2	3.5/5K	55552
		stow and go only	56.5"	2005-2007	1 pcs	no	2x2	3.5/5K	N/A
		stow and go only	53"	2008-2011	1 pcs	no	2x2	3.5/5K	55554
SUV	Trail Blazer/ Duster		34"	1974-1993	3 pcs	yes	2x2	6/10K	57651 ☒
Notes									

☒ While supplies last. Clearance price available.

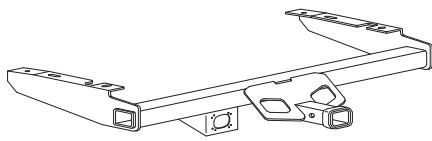

Frame Mounted Receiver

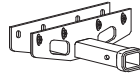

"Stubbie"
Crossmember
Mounted Receiver

Ratings Series	Receiver Size	Weight Distribution		Carrying Weight	
		G.T.W.	T.W.	G.T.W.	T.W.
54000	2x2	3,500 lbs	350 lbs	3,500 lbs	350 lbs
55000	2x2	5,000 lbs	500 lbs	3,500 lbs	350 lbs
56000	2x2	8,000 lbs	800 lbs	5,000 lbs	500 lbs
57000	2x2	10,000 lbs	1,000 lbs	6,000 lbs	600 lbs
58000	2x2	12,000 lbs	1,200 lbs	10,000 lbs	1,000 lbs
59000	2x2	14,000 lbs	1,400 lbs	12,000 lbs	1,200 lbs

Pontiac		Frame	Year	PCS	Drill	Receiver	Rating	Part #
Van	Transport	33"	1997-2006	1 pcs	no	2x2	3.5K	54354
	Montana SV6 inc. AWD	33"	2005-2010	1 pcs	no	2x2	3.5K	54354
SUV	Torrent	43"	2006-2011	1 pcs	no	2x2	3.5K	54476
Saturn		Frame	Year	PCS	Drill	Receiver	Rating	Part #
SUV	Relay inc. AWD	33"	2005-2007	1 pcs	no	2x2	3.5K	54354
	Vue except redline	43"	2002-2007	1 pcs	no	2x2	3.5K	54476
Suzuki		Frame	Year	PCS	Drill	Receiver	Rating	Part #
SUV	Equator	41"	2009-2011	1 pcs	no	2x2	3.5/5K	55827
Toyota		Frame	Year	PCS	Drill	Receiver	Rating	Part #
Van	Toyota Sienna	54"	2004-2011	1 pcs	no	2x2	3.5K	54828
SUV	Toyota Highlander inc. Hybrid	42"	2004-2007	1 pcs	no	2x2	3.5K	54804 ☒
	4 Runner		1987-1995	3 pcs	no	2x2	3.5/5K	55801 ☒
			1996-2002	3 pcs	no	2x2	3.5/5K	55802 ☒
Trucks	Toyota Tacoma	35"	2005-2011	1 pcs	no	2x2	3.5/5K	55827
	Toyota Tundra	41"	2000-2006	1 pcs	no	2x2	5/8K	56825 ☒
Volkswagon		Frame	Year	PCS	Drill	Receiver	Rating	Part #
Van	Routan		2009-2011	1 pcs	no	2x2	3.5/5K	55554

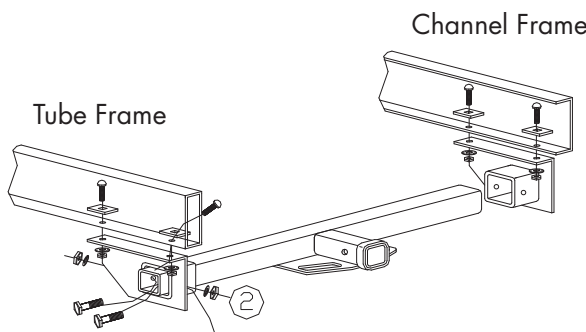

Motorhome (telescoping 3 pcs bolt on end brackets)

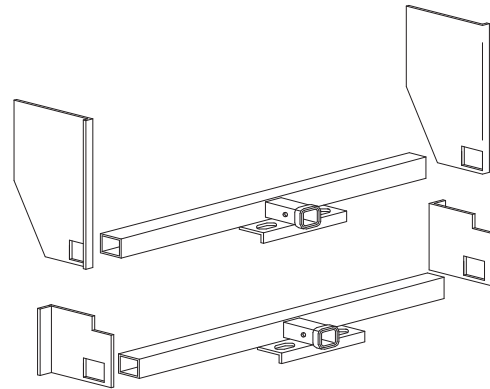

Truck Body Receiver (telescoping weld on brackets)

Motorhome (telescoping 3 pcs bolt on end brackets)		Frame	PCS	Drill	Receiver	Rating	Part #
Motorhome 33" Frame		12" - 33"	3 pcs	yes	2x2	3.5/5K	55701
Motorhome 71" Frame		12" - 71"	3 pcs	yes	2x2	3.5/5K	55702
Motorhome 46" Frame		12" - 46"	3 pcs	yes	2x2	3.5/5K	55703
Truck Body Receiver (telescoping 3 pcs weld on brackets)	Bracket	Frame	PCS	Drill	Receiver	Rating	Part #
Truck Body Receiver	9"x 9.5"	24" - 44"	3 pcs	yes	2 x 2	14/15K	59741
Truck Body Receiver	11"x 21"	24" - 44"	3 pcs	yes	2 x 2	14/15K	59742
Truck Body Receiver	9"x 9.5"	24" - 62"	3 pcs	yes	2 x 2	14/15K	59761
Truck Body Receiver	11"x 21"	24" - 62"	3 pcs	yes	2 x 2	14/15K	59762
Truck Body (Fixed Position one pcs)		Frame	PCS	Drill	Receiver	Rating	Part #
Truck Body Drop 18" Bumper Drop: 18"		44"	1 pcs	yes	2 x 2	14/15K	59777

☒ While supplies last. Clearance price available.

Front Mount Tiedowns

61000 Series

61152 (No Drill)
Ford Super Duty
Short Box 1997 – 2007
Long Box 1997 – 2010

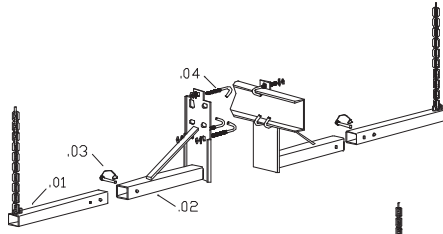

61311 (May Require Drilling)
Chevy/GMC
1500/2500/3500
Long box 1988 – 2000

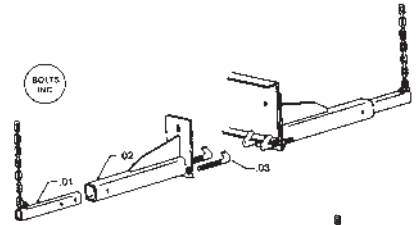

61153 (No Drill)
Ford 150 2004 – 2008
Short box only

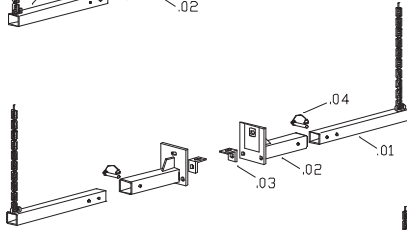

61313 (May Require Drilling)
Chev/GMC
1500 1999 – 2007
2500 Classic 2001 – 2007
3500 Classic 2001 – 2007
*see list for more details

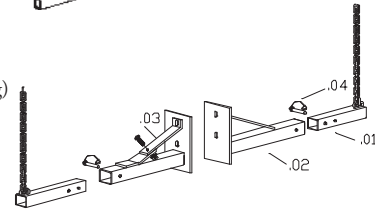

61154 (No Drill)
Ford 150 2004 – 2008
Short box only
2004 – 2008

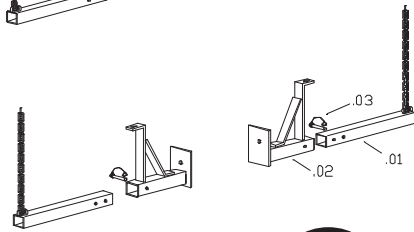

61314 (No Drill)
Classic Channel Frame
1997 – 2009

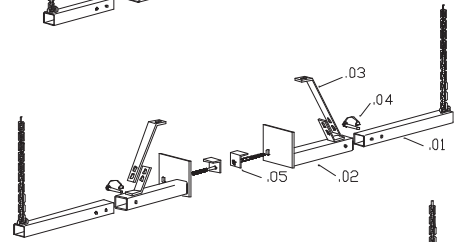

61155 (No Drill)
Ford SD
Short Box 6.5
2008 – 2010

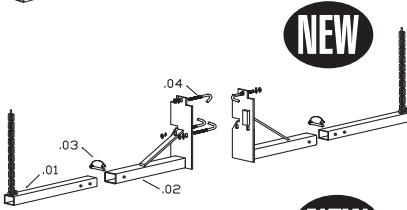

61315 (No Drill)
New Generation
Half Tube Frame
2007 – 2009

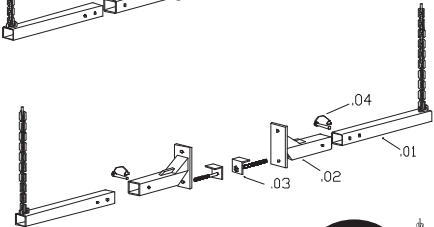

61157 (No Drill)
Ford Super Duty
2008 – 2011
Short box 2000 – 2011

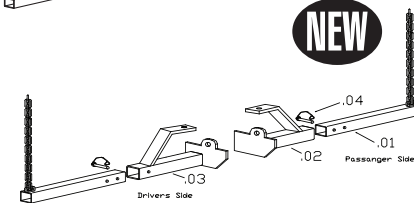

61316 (No Drill)
Chev/GMC 1500
2010 – 2011

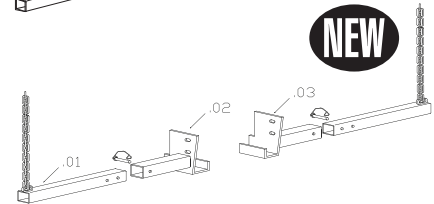

61158 (No Drill)
Ford Super Duty
Long box 2011

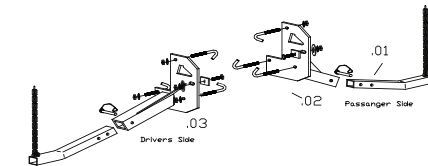

61317 (No Drill)
Chev/GMC 2500/3500
2011

No Drawing Available



61309 (No Drill)
Chev/GMC 1979 – 1987
Dodge 1975 – 2002
Ford 1980 – 1996

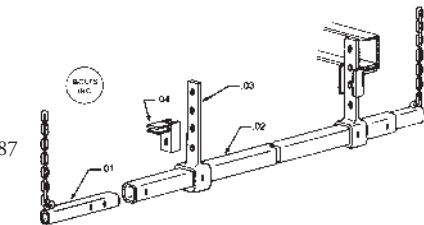

61601 (No Drill)
Dodge Long Box
2003 – 2010

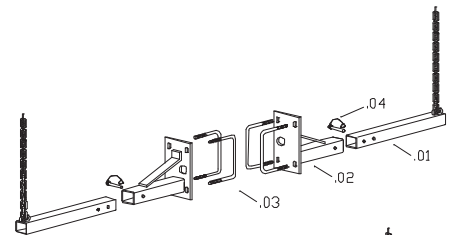

61310 (No Drill)
Chev/GMC 1979 – 1987
Dodge 1975 – 2002
Ford 1980 – 1996

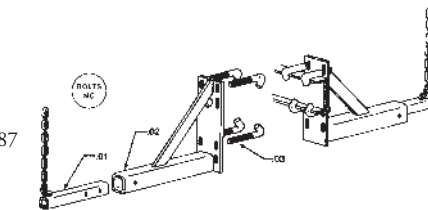

61602 (No Drill)
Dodge Short Box
2003 – 2010
Leaf spring only

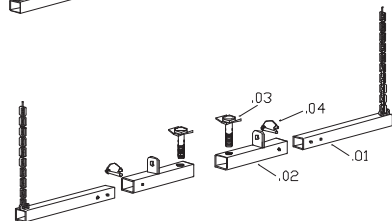

Rear Mount Tiedowns

62000 Series

62702 (Universal)

- Crossbar
 - 2.5" x 2.5"
 - Square
 - No bend

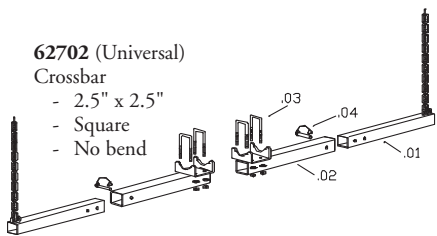

62603

- (Dodge Factory Hitch)

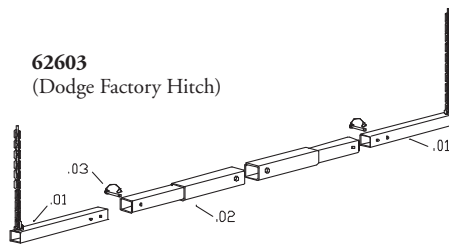

62703 (Universal)

- Crossbar
 - 2.5" x 2.5"
 - Round
 - No bend

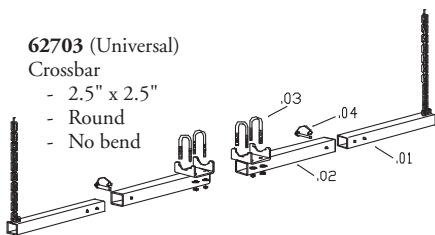

62711 (Universal)

- 2" x 2" Ball Mount
 Mounts

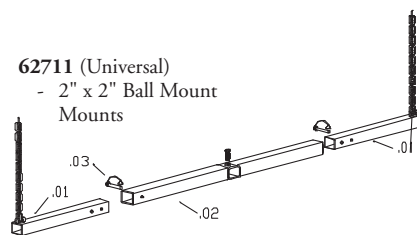

62704 (Universal)

- Crossbar
 - 2.5" x 2.5"
 - Square
 - With bend

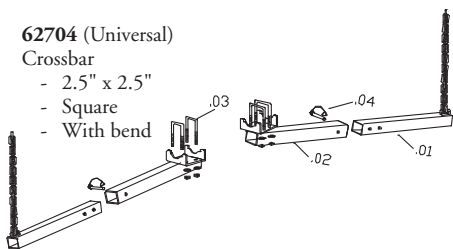

62705 (Universal)

- Crossbar
 - 3" x 3"
 - Square/Round
 - With bend

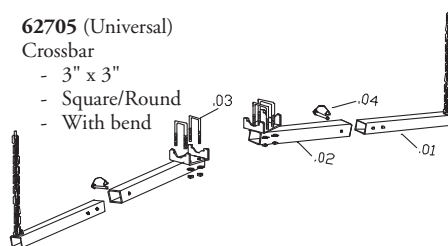

62315 (No Drill)

- Chev/GMC Factory Hitch
 2007 - 2010

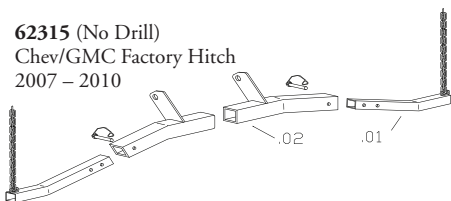

Box Mount

Set of Four

62528

NEW

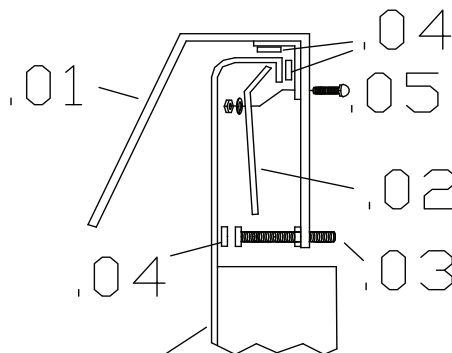
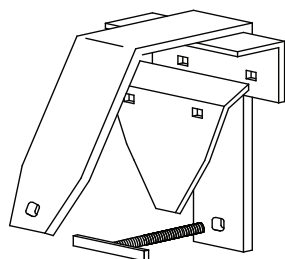

Truck Box

Note: This is not a stake pocket tie down, can also be used with rear mounted tiedowns.

Warning: Not to be used on boxes with no lip or thin material, or composite boxes.

Front Mount Belly Bar

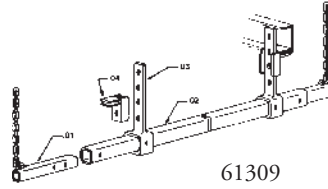

61309

Front Split Mount

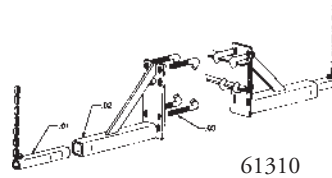

61310

Rear Mount

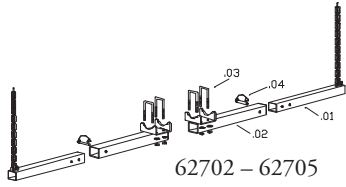

62702 - 62705

Rear Mount Drawbar

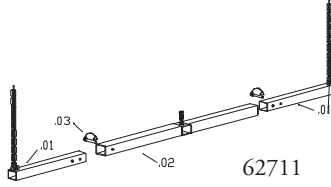

62711

Box Mount



62528

Vehicle					Front Mount		Rear Mount (with Receiver)					Universal Mount	
Model	Year	Box	Cab	Frame	Bellybar (full)	Split Mount	Factory (OEM)	After Market (receiver crossbar)				2" x 2" Draw bar	Box Mount set of 4
								Crossbar 2-1/2" x 2-1/2"		3" x 3"			
								sq. straight	sq. bend	rd. straight	All		
Chev/GMC													
1500	1979-1987	All	All	Channel	61309	61310	⇨	62702	62704	62703	62705	62711	62528
	1988-2000	long only	All	Channel	-	61311	⇨	62702	62704	62703	62705	62711	62528
	1999-2007	All exc 04-07 Crew cab s.box		Channel	-	61313	⇨	62702	62704	62703	62705	62711	62528
	1997-2009	classic	All	Channel	-	61314	⇨	62702	62704	62703	62705	62711	62528
	2007-2009	new gen	All	1/2 Tube	-	61315	⇨	62702	62704	62703	62705	62711	62528
	2010-2011	long box, 2WD	Standard Cab	Tube	-	61316	⇨	62702	62704	62703	62705	62711	62528
2500 & 3500	1979-1987	All	All	Channel	61309	61310	⇨	62702	62704	62703	62705	62711	62528
	1988-2000	long only	All	Channel	-	61311	⇨	62702	62704	62703	62705	62711	62528
	2001-2007	classic	All	Channel	-	61313	⇨	62702	62704	62703	62705	62711	62528
	2007-2010	new gen (2010/2011)	All	1/2 Tube	-	61315	62315	62702	62704	62703	62705	62711	62528
	2011	full tube	All	Full Tube				62702	62704	62703	62705	62711	62528
Dodge													
1500	1975-2002	All	All	Channel	61309	61310	⇨	62702	62704	62703	62705	62711	62528
	2003-2010	All	Reg & Quad	Tube	-	⇨	62603	62702	62704	62703	62705	62711	62528
2500 & 3500	1975-2002	All	All	Channel	61309	61310	⇨	62702	62704	62703	62705	62711	62528
	2006-2008	All 2WD	Mega only	lip chan	-	⇨	⇨	62702	62704	62703	62705	62711	62528
	2003-2010	6.5' only; leaf spring only	All	Tube	-	61602	62603	62702	62704	62703	62705	62711	62528
	2003-2010	8' only	All	Tube	-	61601	62603	62702	62704	62703	62705	62711	62528
Ford													
150	1980-1996	All	All	Channel	61309	61310	⇨	62702	62704	62703	62705	62711	62528
	1997-2003	All	All	Channel	-	⇨	⇨	62702	62704	62703	62705	62711	62528
	2004-2008	short only	All inc Heritage	Tube	-	61153	⇨	62702	62704	62703	62705	62711	62528
	2004-2008	long only	All	Tube	-	61154	⇨	62702	62704	62703	62705	62711	62528
	2009-2010	All	All	Tube	-	⇨	⇨	62702	62704	62703	62705	62711	62528
250 & 350	1980-1996	All	All	Channel	61309	61310	⇨	62702	62704	62703	62705	62711	62528
	1997-2003	All 205 LD	All	Channel	-	⇨	62704	62702	62704	62703	62705	62711	62528
	1997-1998	All HD	All	Channel	-	61152	62704	62702	62704	62703	62705	62711	62528
	1999-2007	long only	All	Channel	-	61152	62704	62702	62704	62703	62705	62711	62528
	2008-2010	short only	All	Channel	-	61155	⇨	62702	62704	62703	62705	62711	62528
	2008-2010	long only	All	Channel	-	61152	⇨	62702	62704	62703	62705	62711	62528
	2008-2010	6.75' short only	All	Channel	-	61157	⇨	62702	62704	62703	62705	62711	62528
	2011	long only	All	Channel	-	61158	⇨	62702	62704	62703	62705	62711	62528
Toyota													
Nissan													

Notes ⇨ For best application see bold listing in chart. For options, will require receiver crossbar size & style
6XXXX Bold underscore = new listings

① Call for instruction

Camper Tiedown Accessories

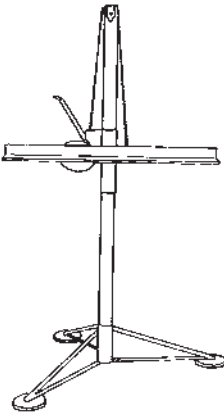
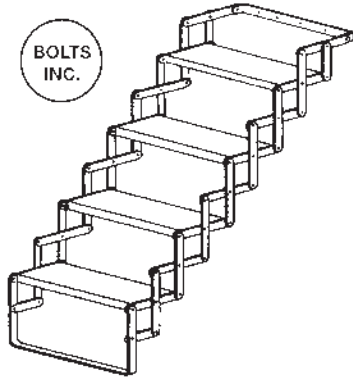
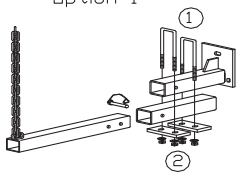
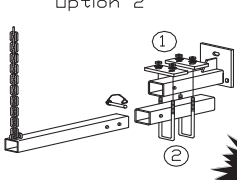
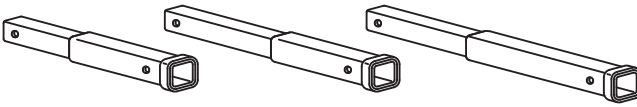
Camper Yard Jack (Folding Winch Style)		Item #	Qty	Capacity	Range	Box #
		64101	2	1000 lbs 453.6 kg	17-57"	
		64102	2	1000 lbs 453.6 kg	17-67"	
<p>- Simple winch design for easy operation - Disassembles into 3 parts for storage - Black Powder Coat finish</p> <p>NEW</p>						
Camper Steps (Scissor Steel Style)		Item #	Steps	Width	Height	Retail
 <p>BOLTS INC.</p>		68473	3	19"	23"	
		68474	4	19"	33"	
		68475	5	19"	43"	
<p>- Mounting hardware included - Fully assembled ready for usage - Folds for storage - Zinc Plated</p> <p>NEW</p>						
Camper Tiedown Adapter for Running Boards		Item #	Description			Retail
<p>Option 1</p> 	<p>Option 2</p> 	61101	CTD Adapter for Running Boards			
<p>- Attaches to camper tiedown with U-Bolts - Drop down tiedown below running boards to avoid altering running boards - Comes in a set - Tube chain and tiedown not included</p> <p>NEW</p>						
Receiver Extensions		Item #	Description	Extends	Ship Wgt	Retail
		43371	2" x 2" (T)	7"	6.4	
		43372	2" x 2" (T)	10"	8.4	
		43373	2" x 2" (T)	14"	10.0	
		43374	2" x 2" (T)	18"	12.2	
		43376	2" x 2" (S)	7"		
		43377	2" x 2" (S)	10"		
		43378	2" x 2" (S)	14"		
		43379	2" x 2" (S)	18"		
<p>T= Tube S= Solid - intended to extend receivers with overhanging campers Note: will reduce WC and WD up to 50%</p>						

The Original (DPO)

The DSP Dual Position "Original" Super Fifth Wheel Hitch (DPO)

- Dual Position:**
- a must for the increasingly popular short box trucks.
 - lift four (4) pins (no tools needed) to set the hitch back 8" when backing into tight areas with short box trucks to prevent damage caused from contact with the RV, which is the same system used by semi-trucks.
 - increases fuel efficiency & traveling ease when the hitch is in travel position.
- Compatible with:**
- DSP Super Fifth Wheels & Sliding Gooseneck Hitches are universal for all pick-up trucks (frame bracket kits may vary, see Page 257).
 - DSP Super Fifth Wheels & Sliding Gooseneck Hitches are interchangeable and fit on slide/bed rails for the same crossbar width.
- Installation:**
- all around solid construction, bolted directly to the frame with grade 5 carriage bolts and 8-3/8" thick frame brackets.

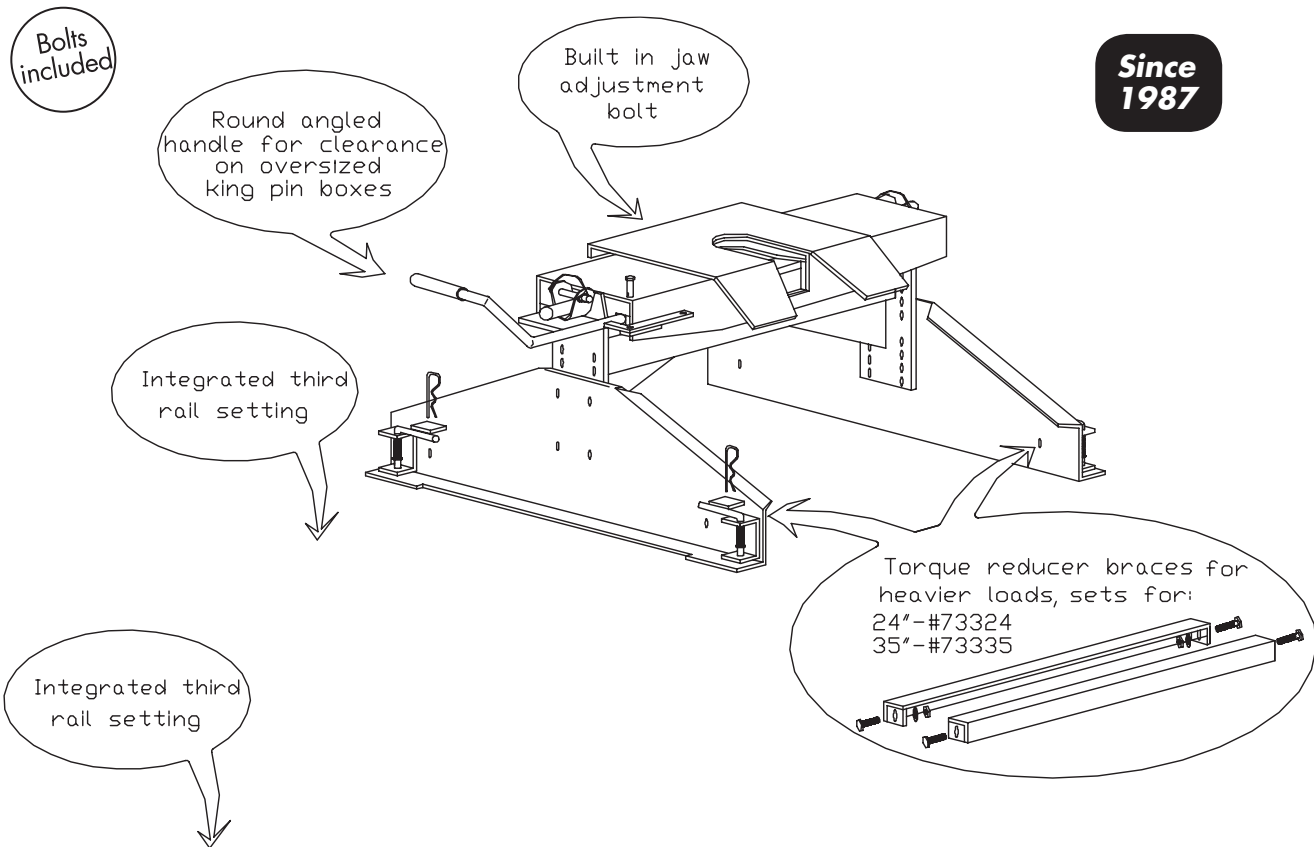

Since 1987

Rails and vehicle specific frame bracket kit sold separately on page 25

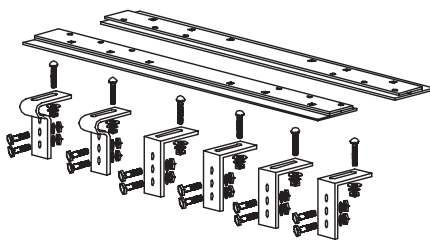

Item #	Crossbar Width	Vertical Load	G.T.W.	Box Numbers	Retail
72994	24"	4,250 lbs 1,932 kg	17,000 lbs 7,728 kg	73101 (CB) 73202 (HBR) S3980 (SD)	
72995	35"	4,250 lbs 1,932 kg	17,000 lbs 7,728 kg	73102 (CB) 73201 (HBR) S3980 (SD)	
72998	35"	5,000 lbs 2,273 kg	20,000 lbs 9,091 kg	73103 (CB) 73201 (HBR) S3980 (SD)	

Also available Rib Spacers #73351 (1pcs)

CB = Crossbar SD = Sides HBR = H-Bracket

The Easy-Level (DPEC)

The DSP Self-Adjusting Dual Position "Easy-Level" Super Fifth Wheel Hitch (DPEL)

- Self-Adjusting:** — spring loaded cradle on the "H" bracket is self adjusting. Made to deal with the difficulties associated with the engaging and disengaging of the RV on unlevel ground, commonly found on campsites. The springs compensate for any small or large angles created by unlevel ground.
- Locking Position:** — built-in locking position restricts the spring loaded device from movement after engaging or disengaging is complete. No extra costs for optional accessories for a locking device!
- Upgrading:** — if you already have a DSP Super Fifth Wheel, the "H" Bracket with the spring loaded device is compatible and interchangeable with all DSP 35" & 24" Super Fifth Wheel Hitches.

All the same benefits as the "Original" Dual Position Super Fifth Wheel (see Page 15).

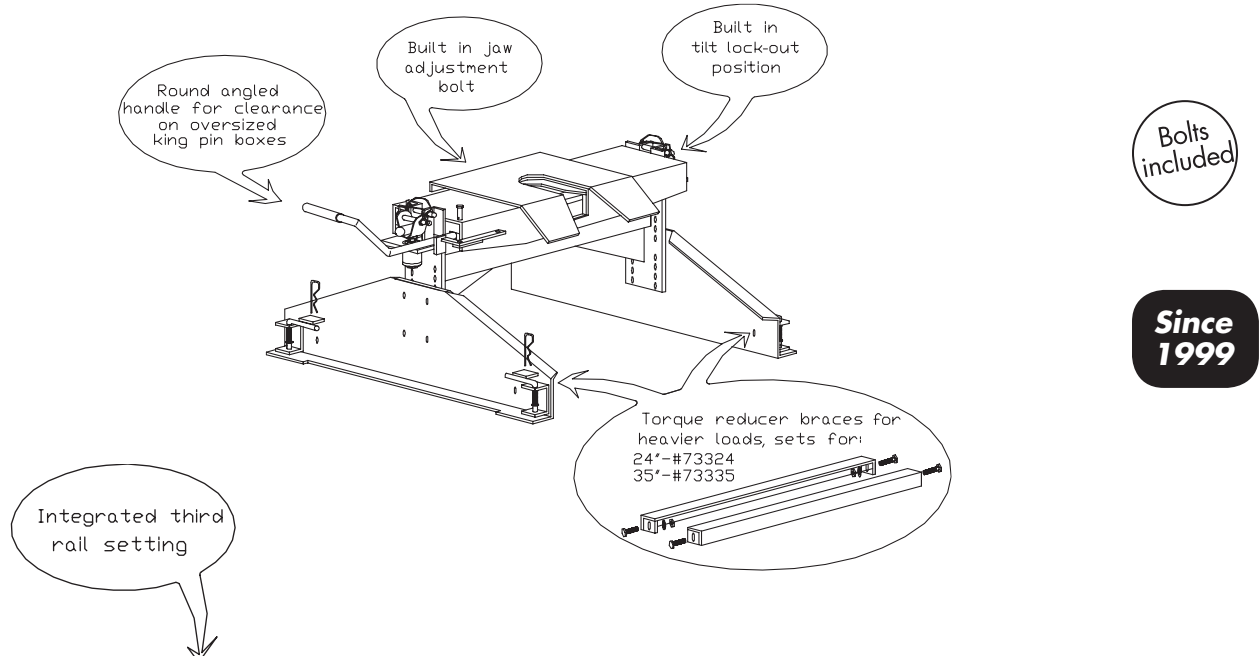

Bolts included

Since 1999

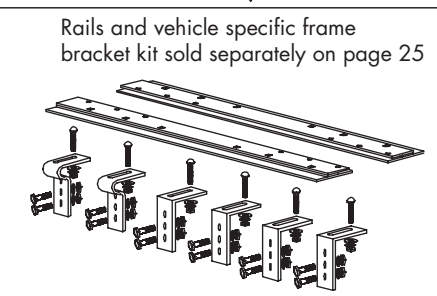

Also available Rib Spacers 73351 (1pcs)

"Easy-Level" Self-Adjusting SFW					
Item #	Crossbar Width	Vertical Load	G.T.W.	Box Numbers	Retail
72996	24"	4,250 lbs 1,932 kg	17,000 lbs 7,728 kg	73101 (CB) S3980 (SD) 73203 (HBR)	
72997	35"	4,250 lbs 1,932 kg	17,000 lbs 7,728 kg	73102 (CB) S3980 (SD) 73204 (HBR)	
72999	35"	5,000 lbs 2,273 kg	20,000 lbs 9,091 kg	73103 (CB) S3980 (SD) 73204 (HBR)	

Self-adjusting

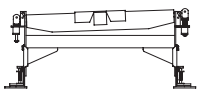

Lock Position

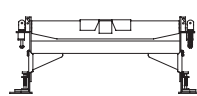

Upgrade

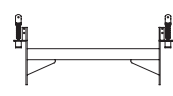

Spring Loaded "H" Bracket Up-Grade		
Item #	Width	Retail
73203	24"	
73204	35"	

CB = Crossbar
 SD = Sides
 HBR = H-Bracket

Please Note: Vehicle Specific Rail Kits found on Page 25.

The Double Tilt (DPDT)

DSP "Double Tilting" Dual Position Super Fifth Wheel Hitch (DPDT)

- Double Tilting** — Double tilting feature intended for traveling on rough terrain while reducing stress on the truck frame, and the trailer pin box and frame.
- Compatible with:** — DSP Super Fifth Wheels & Sliding Gooseneck Hitches are universal for all Pick-up trucks (frame brackets may vary).
- DSP Super Fifth Wheels & Sliding Gooseneck Hitches are interchangeable and fit on slide/bed rails for the same crossbar width.
- Installation:** — all around solid construction, bolted directly to the frame with grade 5 carriage bolts and 8-3/8" thick frame brackets.

All the same benefits as the original Dual Position Fifth Wheels. See page 15.

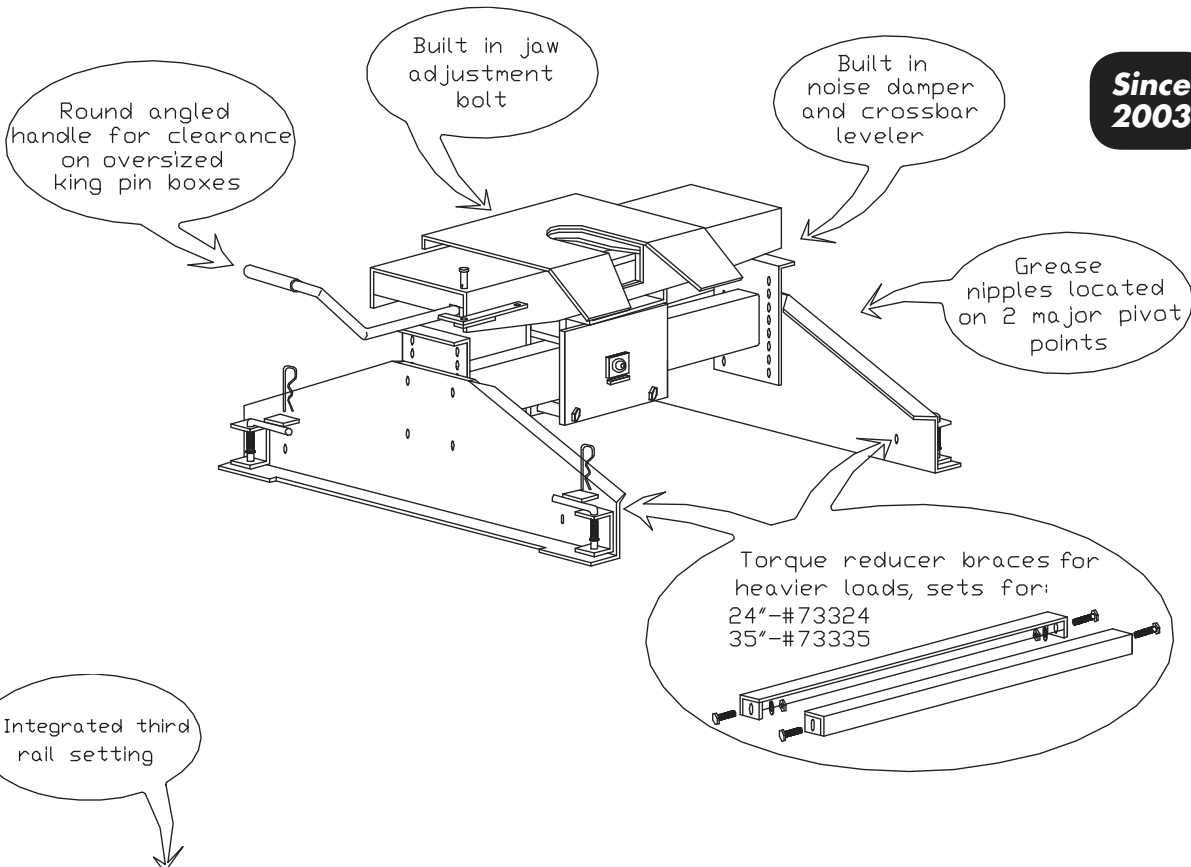

Since 2003

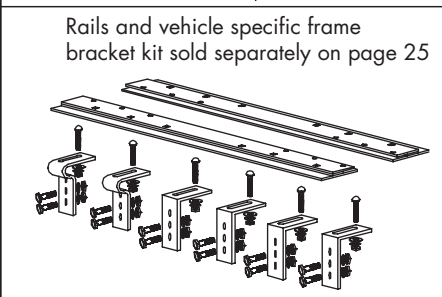

Item #	Crossbar Width	Vertical Load	G.T.W.	Box Numbers	Retail
72991	24" (24 H bracket)	4,250 lbs 1,932 kg	17,000 lbs 7,728 kg	73151 (CB) S3950 (SD) 73215 (HBR)	
72990	35" (35 H bracket)	4,250 lbs 1,932 kg	17,000 lbs 7,728 kg	73151 (CB) S3950 (SD) 73216 (HBR)	

CB = Crossbar
 SD = Sides
 HBR = H-Bracket

Now Available 20K Falcon Series.
 See Page 21

Also available Rib Spacers 73351 (1pcs)

Please Note: Vehicle Specific Rail Kits found on Page 25.

The Cross Beds

Cross Bed Fifth Wheel Hitches "X" Series

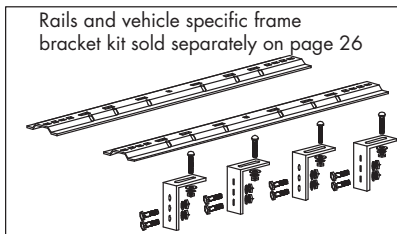
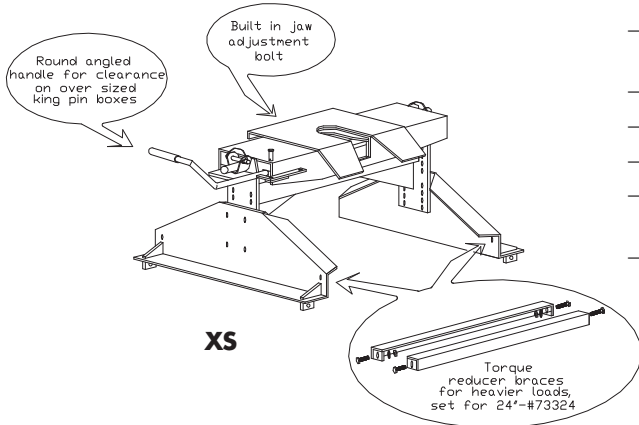

Also available Rib Spacers 73351 (1pcs)

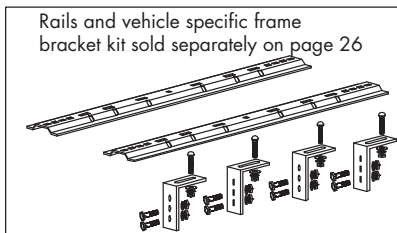
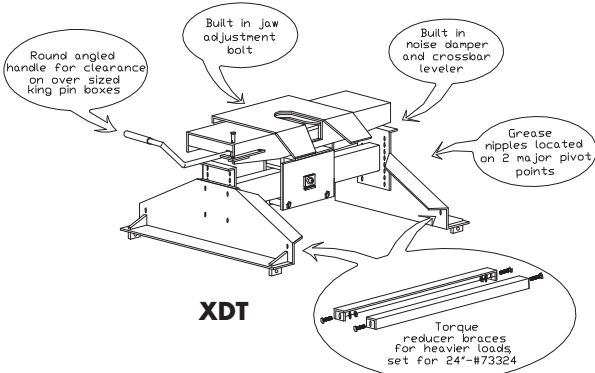

Also available Rib Spacers 73351 (1pcs)

- Solid construction, second to none in the industry
 - Four 5/8" brackets installed directly to the frame with Grade 5-5/8" bolts on Cross Bed Hitches
 - Baked-on powder coat finish
 - Once installed, removes quickly without tools, leaving the 1-1/4" bed rails in the truck bed
 - solid shaft jaw system for definite lock position
 - manual closing device, for safety while in storage
 - Industry standard cross bed rails
 - Vehicle specific rail kits, for easier installation with no need to purchase additional parts for post millennium built trucks
 - 4 box packaging, UPS shippable
- Note: Cross Bed Fifth Wheel Hitches are intended for mostly 8' long box trucks, with proper installation and/or accessories can be installed on 6-1/2' short box trucks, not intended for 5-1/2' boxes

Since 2003

XS Series (Cross Bed Standard)

Order Item #	Cross-bar Width	Vertical Load	Gross Trailer Weight (G.T.W.)	Boxes Packaging	Regular Price
71991	24"	4,250 lbs 1,932 kg	17,000 lbs 7,728 kg	73101 (CB) S3971 (SD) 73202 (HBR)	

- the most economical Fifth Wheel, for the basic towing requirements

Since 2003

XDT Series (Cross Bed Double Tilting)

Order Item #	Cross-bar Width	Vertical Load	Gross Trailer Weight (G.T.W.)	Boxes Packaging	Regular Price
71993	24"	4,250 lbs 1,932 kg	17,000 lbs 7,728 kg	73151 (CB) S3850 (SD) 73215 (HBR)	

- Double tilting feature intended for traveling on rough terrain to reduce stress on the truck frame, trailer pin box & frame

Please Note: Vehicle Specific X Series Cross Bed Rail Kits on page 26

The Falcon

DSP Vice Jaws "V series" System Fifth Wheel Hitches for RV and commercial usage

- the scissor jaw system surrounds the king pin for increased surface area to reduce wear and tear on the jaws on heavy usage RVing or commercial applications.
- 3/4" thick jaws reduce the vertical movement of the trailer king pin which also reduces the wear and tear on the jaw system.
- major pivot points are supplied with grease nipples for easy lubrication to reduce wear and tear.
- replacement parts are available for easy replacement of the jaw system and pins of the pivot points.
- five mounting systems to select from, correct installation application must be applied.
 - Low Profile weld on 32K must be installed by a certified installer.
 - High profile DP Series 20K must have 6 bolts fastened to the Frame Brackets and frame.

**Since
2007**

Low Profile (weld on)

Item #	Vertical Load	G.T.W.	Box Number	Retail
71401	8,000 lbs	32,000 lbs	73181 (CB) 73941 (MH)	

CB = Crossbar
MH = Mounting Hardware

— correct installation is the responsibility of the installer, retailer and end user

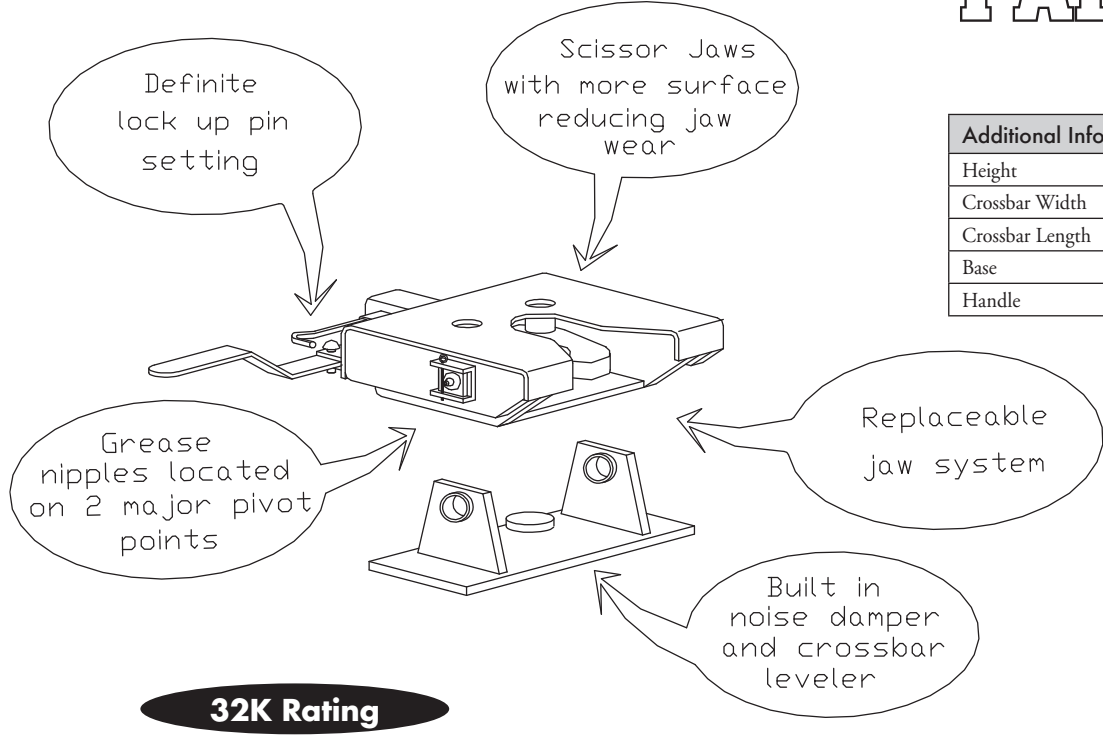

Additional Information	
Height	5-1/2"
Crossbar Width	12"
Crossbar Length	12"
Base	14" x 6.5"
Handle	Additional 8" to width

Replacement Jaw Number	#
Replacement Pin with Grease Nipple	#

The Falcon

DSP Vice Jaws "V series" System Fifth Wheel Hitches for RV and commercial usage

- the scissor jaw system surrounds the king pin for increased surface area to reduce wear and tear on the jaws on heavy usage RVing or commercial applications.
- 3/4" thick jaws reduce the vertical movement of the trailer king pin which also reduces the wear and tear on the jaw system.
- major pivot points are supplied with grease nipples for easy lubrication to reduce wear and tear.
- replacement parts are available for easy replacement of the jaw system and pins of the pivot points.
- five mounting systems to select from, correct installation application must be applied.
 - Low Profile weld on 32K must be installed by a certified installer.
 - High profile DP Series 20K must have 6 bolts fastened to the Frame Brackets and frame.



**Since
2007**

Low Profile (Dual Position "DP" series)	Item #	Rail Width	Vertical Load	G.T.W.	Box Numbers	Retail
	72411	24"	6,250 lbs	25,000 lbs	73181(CB), 73951(MH), S3951(HBR)	
	72412	35"	6,250 lbs	25,000 lbs	73181(CB), 73952(HBR), S3951	

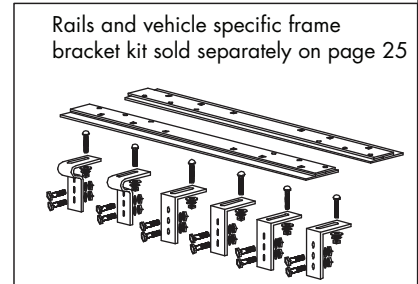
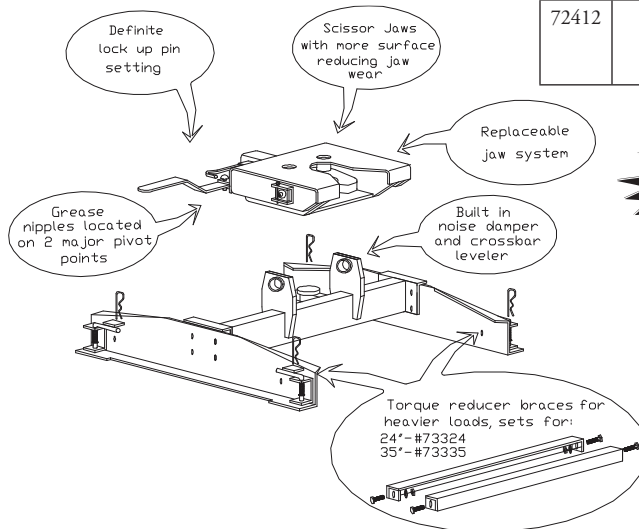

Also available Rib Spacers

Low Profile (Double Tilt "DT" Series)	Item #	Rail Width	Vertical Load	G.T.W.	Box Numbers	Retail
	72421	24"	6,250 lbs	25,000 lbs	73181(CB), 73953(MH), (HBR) S3951(SD)	
	72422	35"	6,250 lbs	25,000 lbs	73181(CB), 73954(HBR), S3951(SD)	

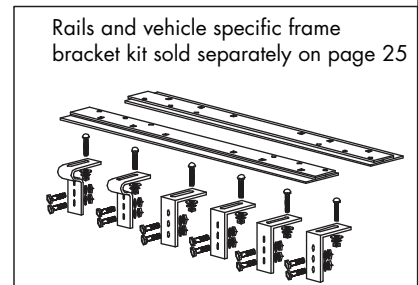
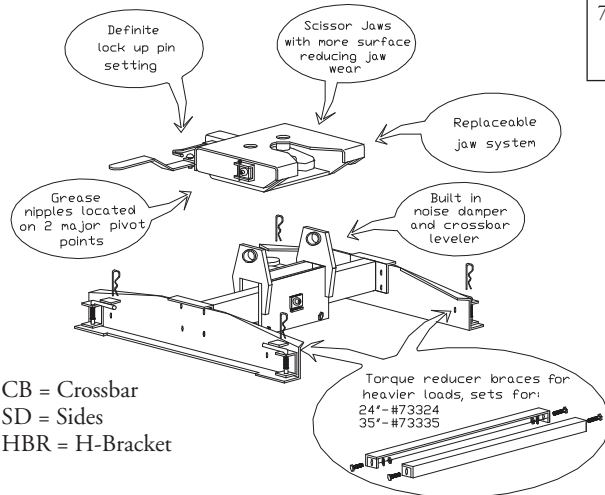

Also available Rib Spacers

CB = Crossbar
 SD = Sides
 HBR = H-Bracket

The Falcon

DSP Vice Jaws "V series" System Fifth Wheel Hitches for RV and commercial usage

- the scissor jaw system surrounds the king pin for increased surface area to reduce wear and tear on the jaws on heavy usage RVing or commercial applications.
- 3/4" thick jaws reduce the vertical movement of the trailer king pin which also reduces the wear and tear on the jaw system.
- major pivot points are supplied with grease nipples for easy lubrication to reduce wear and tear.
- replacement parts are available for easy replacement of the jaw system and pins of the pivot points.
- five mounting systems to select from, correct installation application must be applied.
 - Low Profile weld on 32K must be installed by a certified installer.
 - High profile DP Series 20K must have 6 bolts fastened to the frame brackets and frame.

Since 2007



High Profile (Dual Position "DP" series)	Item #	Rail Width	Vertical Load	G.T.W.	Box Numbers	Retail
	72431	24"	5,000 lbs	20,000 lbs	73181(CB), 73961(HBR), S3950(SD)	
	72432	35"	5,000 lbs	20,000 lbs	73181(CB), 73962(HBR), S3950(SD)	

High Profile 20K

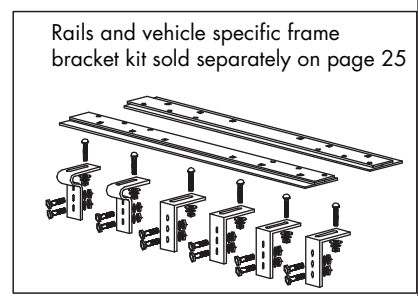

Also available Rib Spacers

High Profile (Double Tilt "DT" Series)	Item #	Rail Width	Vertical Load	G.T.W.	Box Numbers	Retail
	72451	24"	5,000 lbs	20,000 lbs	73181(CB), 73963(HBR), S3950(SD)	
	72452	35"	5,000 lbs	20,000 lbs	73181(CB), 73964(HBR), S3950(SD)	

High Profile 20K

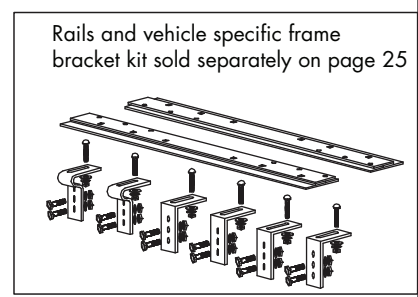

Also available Rib Spacers

CB = Crossbar
SD = Sides
HBR = H-Bracket

The Cross Bed Falcon

DSP Vice Jaws "V series" System Fifth Wheel Hitches for RV and commercial usage

- the scissor jaw system surrounds the king pin for increased surface area to reduce wear and tear on the jaws on heavy usage RVing or commercial applications.
- 3/4" thick jaws reduce the vertical movement of the trailer king pin which also reduces the wear and tear on the jaw system.
- major pivot points are supplied with grease nipples for easy lubrication to reduce wear and tear.
- replacement parts are available for easy replacement of the jaw system and pins of the pivot points.
- five mounting systems to select from, correct installation application must be applied.
 - Low Profile weld on 32K must be installed by a certified installer.
 - High Profile "X" Series 20K must have 4-5/8 bolts fastened to the frame brackets and frame.

Since
2007



Low Profile (Cross Bed "X" series)	Item #	Rail Width	Vertical Load	G.T.W.	Box Number	Retail
	71311	24"	6,250 lbs	25,000 lbs	73181(CB), 73931(HBR), S3840 (SD)	

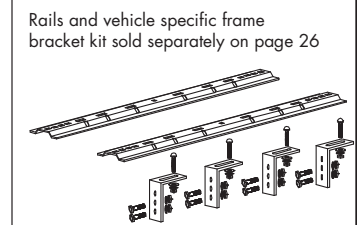
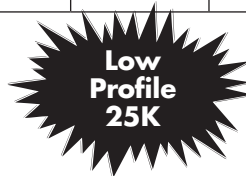
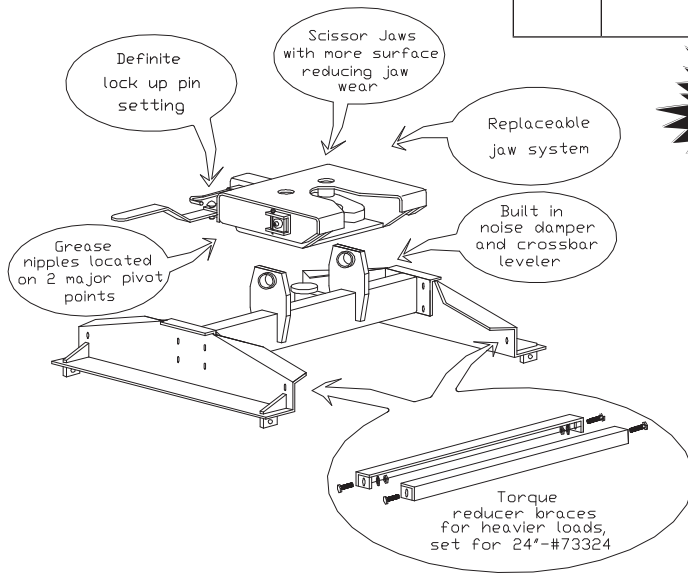

Also available Rib Spacers

Low Profile (Double Tilt "DT" Series)	Item #	Rail Width	Vertical Load	G.T.W.	Box Number	Retail
	71321	24"	6,250 lbs	25,000 lbs	73181(CB), 73932(HBR), S3840(SD)	

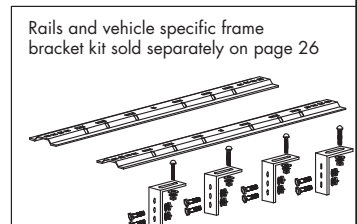
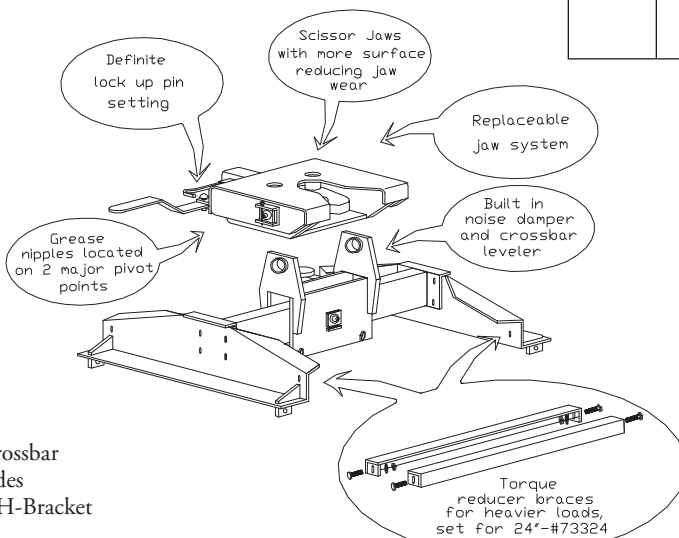

Also available Rib Spacers

CB = Crossbar
 SD = Sides
 HBR = H-Bracket

The Cross Bed Falcon

DSP Vice Jaws "V series" System Fifth Wheel Hitches for RV and commercial usage

- the scissor jaw system surrounds the king pin for increased surface area to reduce wear and tear on the jaws on heavy usage RVing or commercial applications.
- 3/4" thick jaws reduce the vertical movement of the trailer king pin which also reduces the wear and tear on the jaw system.
- major pivot points are supplied with grease nipples for easy lubrication to reduce wear and tear.
- replacement parts are available for easy replacement of the jaw system and pins of the pivot points.
- five mounting systems to select from, correct installation application must be applied.
 - Low Profile weld on 32K must be installed by a certified installer.
 - High Profile "X" Series 20K must have 4-5/8 bolts fastened to the frame brackets and frame.

Since 2007



High Profile (Cross Bed "X" series)	Item #	Rail Width	Vertical Load	G.T.W.	Box Number	Retail
	71311	24"	5,000 lbs	20,000 lbs	73181(CB), 73941(HBR), S3850 (SD)	

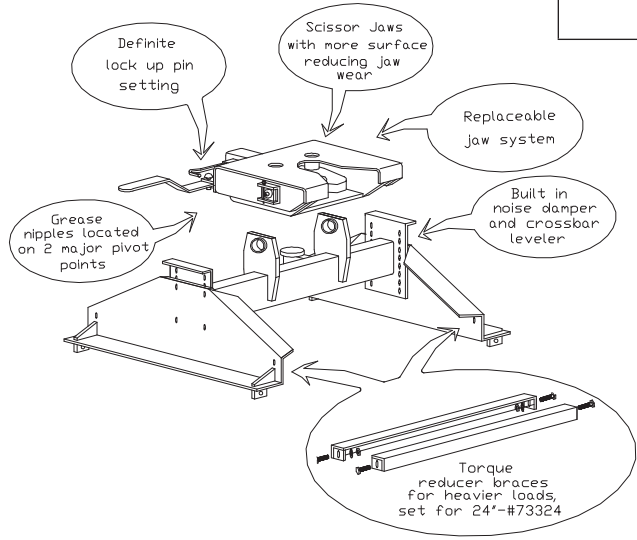

High Profile 20K

Rails and vehicle specific frame bracket kit sold separately on page 26

Also available Rib Spacers

High Profile (Double Tilt "DT" Series)	Item #	Rail Width	Vertical Load	G.T.W.	Box Number	Retail
	71341	24"	5,000 lbs	20,000 lbs	73181(CB), 73942(HBR), S3850(SD)	

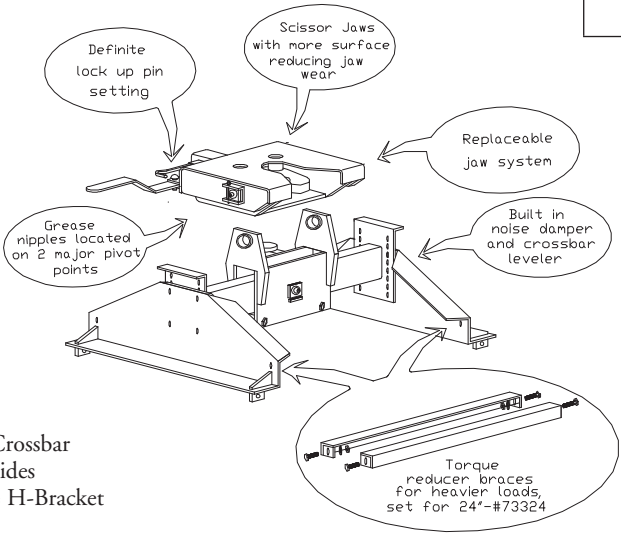

High Profile 20K

Rails and vehicle specific frame bracket kit sold separately on page 26

Also available Rib Spacers

CB = Crossbar
SD = Sides
HBR = H-Bracket

Gooseneck Hitches

The DSP "Sliding Gooseneck" Hitch

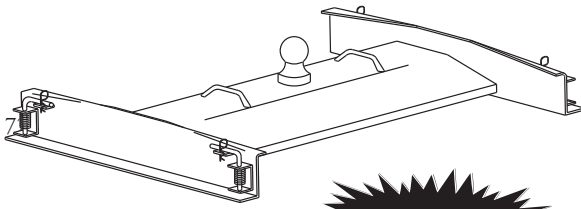

Bolts included

Now shipped in 2 boxes

Note: Distance of truck bed to top of Hitchball is 8.5" to 9"

Item #	Width	Ver. Load	G.T.W.	Box numbers	Retail
72924	24"	6,500 lbs 2,954 kg	26,000 lbs 11,818 kg	G2924(CB) S3302(MH)	
72935	35"	6,500 lbs 2,954 kg	26,000 lbs 11,818 kg	G2935(CB) S3302(MH)	
72937	37"	6,500 lbs 2,954 kg	26,000 lbs 11,818 kg	G2935(CB) S33??(MH)	

Installation:

- unlike a folding ball, a large hole does not need to be cut into the truck bed, just 6-1/2" holes need to be drilled.
- fabrication of Mounting Hardware is not required, all parts are available from DSP.
- all around solid construction, bolted directly to the frame with Grade 5 Carriage Bolts and 8-3/8" thick Frame Brackets.

Compatible with:

- DSP Super Fifth Wheels & Sliding Gooseneck Hitches are universal for all pick-up trucks (Frame Brackets may vary, see Page 25).

Warning:

- vehicles towing 26,000 lbs must have the correct towing package.
- warranty is void with the usage of parts other than DSP products, exceeding hitch G.T.W. and alterations to products.

Note:

- Slide/Bed Rails and frame brackets are sold separately.
- threaded king pin (part # 73702) and Hitchball (part # 73703) are interchangeable.

Rails and vehicle specific frame bracket kit sold separately on page 25

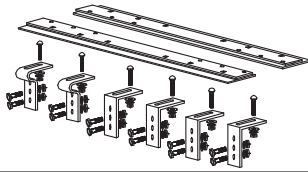

CB = Crossbar MH = Mounting Hardware

DSP "X Series" Crossbed Gooseneck Hitch

Item #	Width	Ver. Load	G.T.W.	Retail
71923	N/A	6,500 lbs 2,954 kg	26,000 lbs 11,818 kg	

- Heavy duty construction.
- Easy to remove.
- Compatible with all major brands of cross bed rails.
- Rails and frame brackets kit not included.
- Pin and clips sold separately #73831 (4 pk)

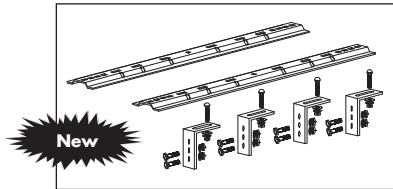
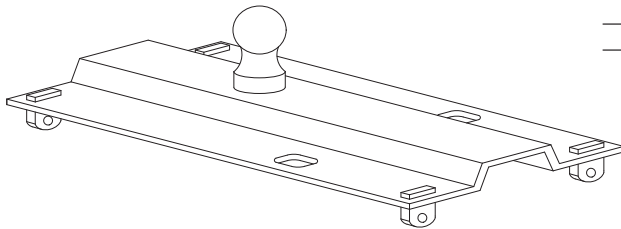

26K Hide Away Hitch Ball

NEW

26K Rating

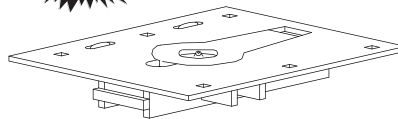
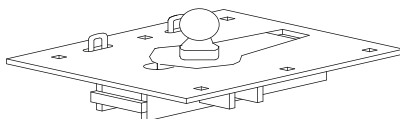

Item #	Vertical Load	G.T.W.
74710	6,500 lbs 2,954 kg	26,000 lbs 11,818 kg

- Completely flush when closed
- 3/8" Top Plate and trap door
 - integrated stabilizer ring with key stone shape door
 - counter sunk 1/2" safety chains links
 - grease nip assessable when closed

Dual Position Installation

Frame Bracket Application and Bed Rail Installation for Dual Position Fifth Wheel Hitches

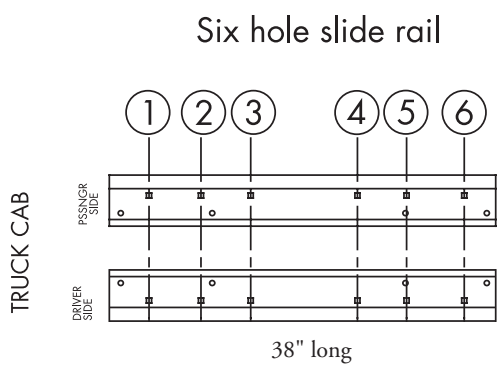
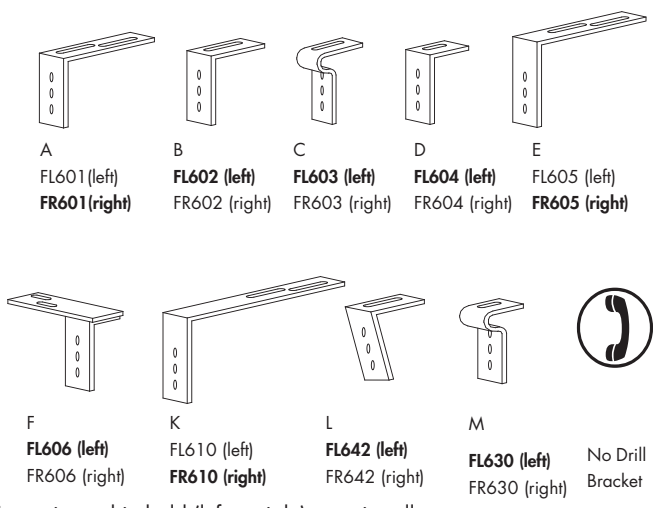

Note: 4 hole rail (1987 – 2000) holes 1, 3, 4, 6
See chart below for compatibility.

Make	Year	Model (frame)	Vehicle Specific Rail Kit		Drill app	Best app easy install	Compact Box (6.3')	Short Box (6.5')	Long Box (8')	Rail Length 38"										
			24"	35"						DSP 24"			DSP 35"							
										1	2	3	4	5	6	1	2	3	4	5
Ford																				
F-Series	2011	F150																		
	2011	Super Duty																		
	2008-2010	Super Duty	72793	72718	yes	35		21.25	21.25					L	B		F			
	2004-2010	150 (tube)	72717	72719	no	35		19.75	20.5	⊙	⊙		⊙	⊙	⊙					
	2004-2007	Light Duty (ch)	72793	72715	yes	35		20.5	20.5	A	A		A	D	D		B			
		Super Duty (ch)	72793	72792	yes	35		21.25	21.25	A	A		A	C	B		B			
	1997-2003	Light Duty (ch)	72793	72715	yes	35		20.5	21.25	A	A		A	D	D		B			
		Super Duty (ch)	72793	72792	yes	35		20.5	21.25	A	A		A	C	B		B			
1973-1996	all (channel)	72793	72792	yes	35		19	23.25	A	A		A	C	B		B				
Ranger	1984-2011	all		N/A		24											use 24"			
Chev/GMC																				
Silver & Sierra	2011	Tube Frame	72749	72745	yes	35		18	25		A	A		A		M	M		M	
	2009-2010	New Generation	72793	72744	yes	35		18	23	A	A		A		A	C	C			
	1999-2011	Lt. Duty (classic)	72793	72743	yes	35		18	23	A	A		A		C	C	B			
		Hvy Duty (new frame)	72732	72743	yes	35		18	23	E	E		A	B		C	C			
	1988-1998	all (classic)	72793	72743	yes	35		18	23	A	A		A		C	C	B			
1967-1987	all (classic)	72793	72764	yes	35		18	23	A	A		A		B		B	B		B	
Dodge																				
Ram	2008-2011	1500 coil spring only	72751	72768	yes	35		18.75	21.5			K		K	K		C		C	C
	2003-2011	all (tube frame)	72751	72765	yes	35		19	21.5			K	K		K		C	C		F
	2001-2002	1500 only (tube frame)	72751	72765	yes	35		19	21.5			K	K		K		C	C		F
		2500 & up (channel)	72793	72764	yes	35		19	21.5		A	A		A		B	B		B	
	1973-2001	all (channel)	72793	72764	yes	35		18.25	21.75	A			A		A	B			B	B
Dakota	1987-2007	all		N/A		24														use 24"
Toyota																				
Tundra	2000-2007	reg & ext inc 4X4	72732	72781	yes	24		25				E	E	A			A	E	A	
															E		A		A	
T-100	2000-2007	reg & ext inc 4X4		N/A		24														use 24"

NOTE: RAIL KIT LISTED ABOVE IN GREY ARE BASED ON AND SUPPLIED WITH SIX HOLE RAILS ONLY

To order frame bracket kit only — replace first three digits of Rail Kit number with "727__" or "737__"

Cross Bed Installation

Frame Bracket and Bed Rail Installation for Cross Bed Fifth Wheel Hitches

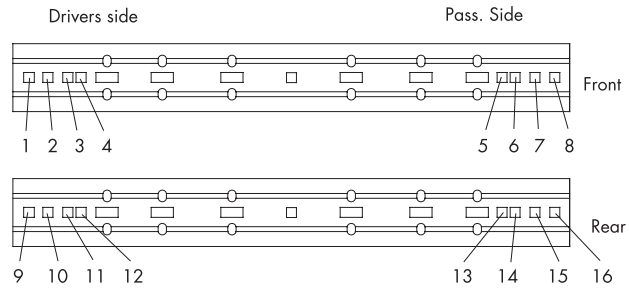
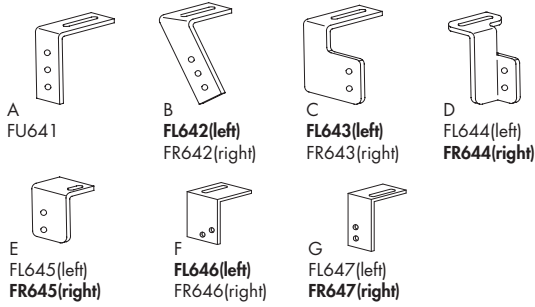

Item pictured in bold (left or right)

Make	Year	Model	Vehicle Specific Rail Kit	drill app	Centre of rear rail to edge of truck bed			Ahead of Axle	Holes to use in Bed Rail Frame Bracket			
					Compact Box (6.3')	Short Box (6.5')	Long Box (8')		Front Bed Rail		Rear Bed Rail	
									Driver Side	Passenger Side	Driver Side	Passenger Side
Ford												
F-series	2008-2011	Super Duty										
	2004-2011	150 reg & super cab	71716	yes	29 1/2"	29 1/2"		2 (f)	7 (f)	11 (g)	14 (g)	
	1999-2007	250, 350 Super Duty	71715	yes	31 3/4"	31 3/4"		1 (a)	8 (a)	9 (c)	16 (c)	
	1997-2003	150 (Light Duty & 1998 F-250)	71731	yes	29 1/4"	29 1/4"	3/4"	3 (a)	6 (a)	11 (a)	14 (a)	
	2000-2001	450, 550 Super Duty	71771	yes	37 1/2"			2 (b)	4 (b)	10 (a)	15 (a)	
	1992-1998	350, 250 (97 - 98) S.D.	71771	yes	31 3/4"	31 3/4"		1 (b)	8 (b)	9 (a)	16 (a)	
	1989-1996	150, 250	71771	yes	32"	32"		1 (b)	8 (b)	9 (a)	16 (a)	
1973-1988	all	71771	yes	32"			1 (b)	8 (b)	9 (a)	16 (a)		
Chev/ GMC												
Silver. & Sierra	2011											
	2001-2003	1500, 2500 Heavy Duty	71731	yes	28"			2 (a)	7 (a)	1 (a)	14 (a)	
	2001-2010	3500 HD inc Quad cab	71731	yes	34"			2 (a)	7 (a)	10 (a)	15 (a)	
	2001-2010	2500 Heavy Duty	71731	yes	30"	33 3/4"		2 (a)	7 (a)	10 (a)	15 (a)	
	1999-2007	1500, 2500	71731	yes	28"	32"		2 (a)	7 (a)	10 (a)	15 (a)	
	1988-1998	1500, 2500, 3500	71731	yes	34 1/4"			2 (a)	7 (a)	11 (a)	14 (a)	
	1998-2000	3500	71731	yes								
	1988-1998	1500, 2500, 3500	71731	yes	28"			2 (a)	7 (a)	10 (a)	15 (a)	
	1998-2000	3500	71731	yes								
1987-pre	all	71762	yes	34 1/2"	34 1/4"		1 (a) +	8 (a) +	9 (b)	16 (b)		
Dodge												
Ram	2002-2010	1500 (4x2 & 4x4)	71733	yes	32"	34"		2 (d)	5 (d)	13 (e)	12 (e)	
	2003-2009	3500 (4x2 only)	71762	yes	32"	34"		1 (a)	8 (a)	8 (e) +	13 (b) +	
	1998-2001	1500	71761	yes	34 1/2"			1 (a)	8 (a)	9 (a) +	16 (a) +	
	1998-2002	2500, 3500	71732	yes								
	1994-1997	1500, 2500, 3500	71732	yes	35 1/2"			1 (a)	8 (a)	9 (a) +	16 (a) +	
	1994-2001	1500, 2500	71732	yes	31"			1 (a)	8 (a)	9 (a) +	16 (a) +	
	1993-pre	all	71731	yes	37"			3 (a)	6 (a)	11 (a)	14 (a)	
Dakota	2002-earlier		71731	yes	29"			3 (a)	6 (a)	11 (a)	14 (a)	
	2003-2007	not including quad cab	71771	yes	28"			3 (a)	6 (a)	11 (a)	14 (a)	
Toyota												
Tundra	2000-2007	reg & extend cab (inc 4x4)	71731	yes	35"			1 (a)	8 (a)	9 (a)	16 (a)	
T100	2000-earlier	reg & extend cab (inc 4x4)	71731	yes	39"			1 (a)	8 (a)	9 (a)	16 (a)	

+ Must drill through cross member on frame to install, longer carriage bolts required

To order frame bracket kit only — replace first three digits of Rail Kit number with "711_ _" or "717_ _"

For quick listing of the frame bracket kit box contents please see page 38.

Motorhome Towing Systems

DSP Classic Folding Towbar

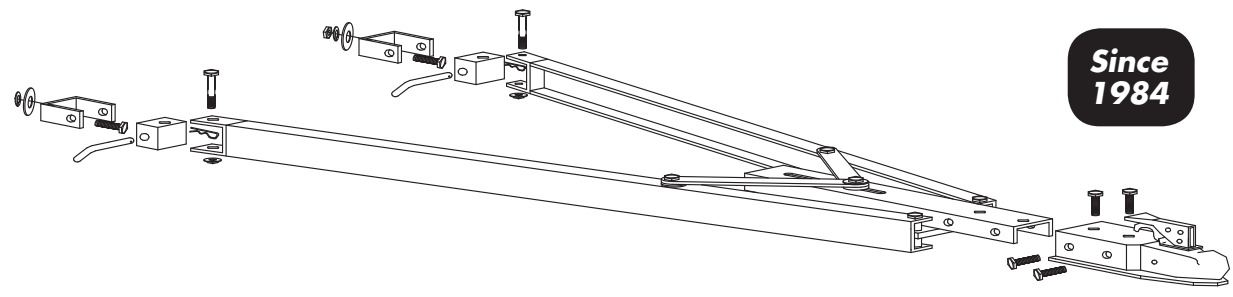

Since 1984

- mounting brackets must be attached to the frame
- 1/2" pins are for the quick and easy removal
- Maximum width 40" / 101.5cm
- coupler must be pinned or locked before towing
- **MUST BE USED WITH SAFETY CHAINS**
- Powder Coated Finish

Item #	Capacity	Ship. Wgt
81351	3,500 lbs/ 1,590 kg	
81501	5,000 lbs/ 2,272 kg	

Motorhome Adapters/Towbar Adapters

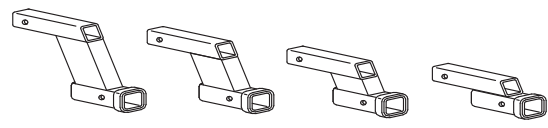

Item #	Description	Ship. Wgt
43381	Drop: 2" Receiver: 2x2 (T)	7.6 lbs.
43382	Drop: 4" Receiver: 2x2 (T)	
43383	Drop: 6" Receiver: 2x2 (T)	
43384	Drop: 8" Receiver: 2x2 (T)	
43386	Drop: 2" Receiver: 2x2 (S)	
43388	Drop: 6" Receiver: 2x2 (S)	

- 2 x 2 Receiver T=Tube S=Solid
- Rated 6,000 lbs
- Powder Coated Finish

Motorhome Receivers (with bolt on end brackets)

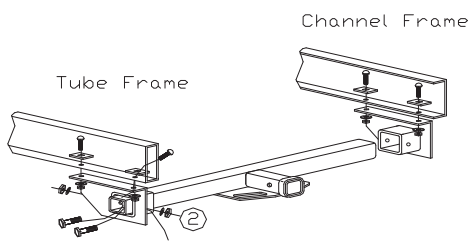

Item #	Description	Ship. Wgt
55701	24"-33" frame	
55702	24"-71" frame	
55703	24"-46" frame	

- 2 x 2 Receiver
- for Channel or tube frame
- Rated 3,500/5,000lbs
- Powder Coated Finish

Truck Body Receivers (with weld on end brackets)

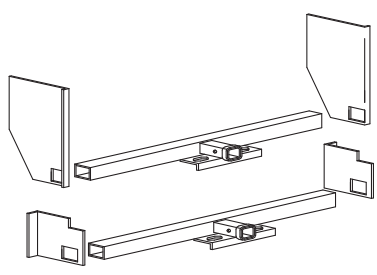

Item #	Description	Ship. Wgt
59741	width: 44" Bracket: 9"x 9.5"	
59742	width: 44" Bracket: 11"x 21"	
59761	width: 62" Bracket: 9"x 9.5"	
59762	width: 62" Bracket: 11"x 21"	

- Heavy duty construction rating:14/15K
- must be welded by certified welder
- 2 x 2 receiver
- Powder Coated Finish

DSP Headache Racks & Side Rails

Features: 4 styles to choose from, Zinc Plated, Tube: 0.125 wall, Pre drilled holes for installation
Also available special order only, bare metal or black powder coating.

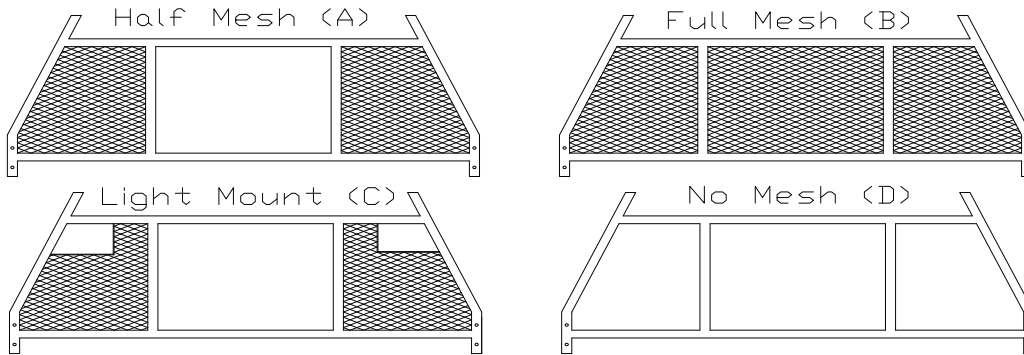

Make Model & Main Frame				Half Mesh (A)	Full Mesh (B)	Light Mount (C)	No Mesh (D)	Rear (R) Not Illustrated
Chev/GMC (Main Frame 84412)	Box	Year						
Silverado/Sierra	new body	All	2007-2010 ☉	84412-A	84412-B	84412-C	84412-D	84701-R
Silverado/Sierra	classic	All	1988-2007	84412-A	84412-B	84412-C	84412-D	84701-R
Dodge (Main Frame 84611)	Box	Years						
Ram 1500	All	1994-2010 ☉		84611-A	84611-B	84611-C	84611-D	84701-R
Ram 2500 & 3500	All	1995-2010 ☉		84611-A	84611-B	84611-C	84611-D	84701-R
Ford (Main Frame 84110)	Box	Years						
F-250, F-350 Super duty	All	1999-2010 ☉		84110-A	84110-B	84110-C	84110-D	84701-R
		1997-2010 ☉		84110-A	84110-B	84110-C	84110-D	84701-R
F-Series	All	1973-1996						
Ford (Main Frame 84109)	Box	Years						
F-150	All	2004-2010 ☉		84109-A	84109-B	84109-C	84109-D	84701-R
F-150 & LD 250 inc 04 Heritage	All	1997-2003						

☉ This catalogue was printed in Nov. 2010. For any 2011 updates, please call

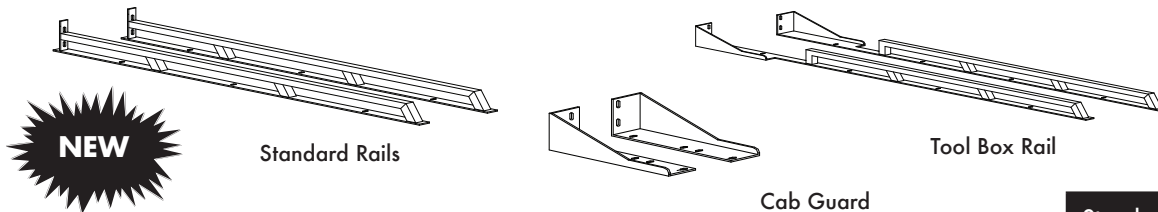

Side Rails	Box	Cab	Standard Side Rail	Tool Box Side Rail
Long Box	8'	Universal	85780-S	85780-T
Short Box	6.5'	Universal	85765-S	85765-T
Compact Box	5.5'	Ford crew	85755-S	85755-T
Cab Guard (no rails)	All	Universal	86711-G	
Bolt Pack	All	Universal	8500-B	

Protector Caps (Sold in bundles of 20)			Tire Chain Hooks (Sold in boxes of 100)		
Item	Description		Item	Description	
20013	Chain Caps		32300	Boomer Hooks	
20014	Strap Caps		32100	Clevis Hooks	
			32200	C Hooks	

DSPTM

HITCHES

Polar Sled Lock



*REST ASSURED
YOUR SLED IS SAFE*

Toll free: 1-800-265-3377 • www.dsphitches.com
MADE IN CANADA

What's holding your sled down?
*Introducing the Polar Sled-Lock (39111)
the newest in sled tie down devices.*

This easy to install, heavy-duty sled clasp is perfect to keep your sled safe and secure on your truck or trailer.

- Canadian Made and Designed – ready to handle tough Canadian winters!
- Effective theft prevention with a standard pad lock



- Fits all sled makes and models
- Does not require professional installation – easy, do-it-yourself, installation process!
- Made of high quality steel tubing
- Durable Black Powder-Coated finish
- Snow and ice resistant rubber pads to protect your skis from damage

Makes a great gift!

Item # 39111

DSP TERMS AND CONDITIONS OF SALES

PAYMENT & PRICING TERMS

- Net 30 calendar days from invoice date
- 2% discount on subtotal, when payment is received by the 10th calendar day from invoice date
- Customers with an unpaid invoice(s) over 60 days will not be shipped additional goods until account is current
- NSF Cheques and others are subject to a \$75.00 surcharge
- Overdue accounts are subject to a 2% interest per month (24% per year)
- Prices and conditions of sale are subject to change without notice

ORDER PLACEMENT

- Orders can be placed by calling the DSP customer service department, fax or email.
- Same day shipping deadline is 1:00 pm. Orders placed after 1:00 pm will be shipped on the next business day.
- Pick-up orders require a minimum 1 hour preparation time during peak season
- Special Order cannot be cancelled or returned once placed.

FREIGHT/SHIPPING

- Prepaid for the (invoice subtotal) minimum orders as indicated in the chart below. All invoices will be charged freight, then it can only be deducted should the invoice payment be received on or before the invoice due date. For all orders under the PPD minimums, freight charges as outlined below will be added to each invoice.
- Freight charges are subject to change resulting from the fluctuation of fuel surcharges.
- The conditions do not apply to power tailgate delivery surcharges

Important Update see following chart new Freight Territories

Destinations	PPD Minimum (Invoice subtotal)
BC Vancouver Island	\$3,500
BC Lower ML & Kootneys	\$3,000
BC Northern & Okanagan	\$2,500
AB Edmonton-Calgary	\$1,500
AB Northern & Southern	\$2,500

Destinations	PPD Minimum (Invoice subtotal)
Saskatchewan	\$3,000
Manitoba	\$3,500
Southern Ontario	\$4,000
Northern Ontario	\$6,000



LOST OR DAMAGED GOODS

- All complaints for lost, damaged, or short shipped goods must be submitted to a DSP Customer Service Representative within 24 hours following the reception of an order. We recommend to attentively inspect each article at the time of the reception and to communicate with the customer service department to ensure reasonable tracing can be done.

RETURNS POLICY

- All returns request must be authorized with a Returned Goods Authorization (RGA) Number. This can be issued by calling a DSP Customer service representative
- All return requests must be accompanied by a copy of the original bill of sale. No Exceptions.
- No refunds, credit to account only.
- All returns are subject to a 25% restocking charge. Restocking charge may be waived should the product be returned in a directly saleable condition (ie complete without repackaging) and should an order equal to or greater than the value (subtotal) be shipped at the time of the RGA request.
- All returns are subject to a 33% Broken Kit charge. Should the product NOT be returned in a directly saleable condition (ie any componants missing).
- Any stock return must be sent prepaid
- All merchandise which has been modified, painted or installed will be refused and returned at the customers expense. The same applies should the product not be a DSP product.
- Any returns of discontinued items purchased within the last calendar year may be accepted, but would be considered only on a case to case basis. Please inquire with the DSP Customer Service Representative.
- Any discontinued items purchased through a liquidation sale will be refused
- Any Special order items cannot be returned.

DSP's Warranty Policy & Limited Warranty

Diversified Steel Products Mfg. Ltd. (hereinafter called the company) warrants THE ORIGINAL PURCHASER ONLY of the DSP products listed below. To make good by repair or replacement of any part, which is shown to the Company's satisfaction to be defective under usage in any materials or proper workmanship within the warranty listed below, within the original date of purchase. This warranty does not apply to the damage resulting from common daily wear and tear,* improper installation or misuse.

The company does not cover finish placed on products. Accordingly, the company will not replace, repair or refinish any products if the finish on the product is worn in any manner.

The company's liability shall be limited to make good repair, replacement or refitting free of charge any defective parts provided such parts are promptly returned to the retailer. Transport charges on parts are to be paid by the customer.

This warranty is in lieu of all warranty conditions or liabilities implied by law or expressed by statute. In the event shall the Company be liable for consequential damage, the Company shall not be bound by any conditions. Warranties or representatives, save as herein contained, unless same are in writing and signed by duly appointed officer of the Company.

This warranty will only come into effect when the customer (end user or general public) returns a DSP warranty card within thirty (30) days of purchase. FOR ANY ADJUSTMENT, RETURN OR CLAIM CALL 1-800-265-3377 for claim and authorization number, including information on DSP claim and return terms on policy and procedures.

For warranty procedures see your local DSP retailer or call DSP at 1-800-265-3377.

*Common wear and tear is considered direct friction created from metal contact. Lubricants used, such as grease, will trap in foreign materials creating a grinding compound and is also common daily wear and tear. Keeping clean before use should reduce this. For lubrication on all moving parts for DSP products, use graphite spray and clean before using. For reduction of metal to metal contact on DSP Fifth Wheel Horseshoes (on crossbar) use a replaceable teflon plate.

DSP Limited Warranties are:	
DSP Weight Distribution Hitch Systems	— Lifetime Limited Warranty
DSP Ballmounts	— Five (5) Year Limited Warranty
DSP Adjustable and Specialty Ballmounts	— Five (5) Year Limited Warranty
DSP Hitchballs	— Five (5) Year Limited Warranty
DSP Camper Tiedowns	— Five (5) Year Limited Warranty
DSP Super Fifth Wheel Hitches	— Five (5) Year Limited Warranty
DSP Gooseneck Hitches	— Five (5) Year Limited Warranty
DSP Bolt On Hitch Receivers	— Five (5) Year Limited Warranty

Note: all products used by professional haulers are subject to DSP's one (1) year limited warranty.

DSP Warranty Policy & Procedure

Credit or repair, according to DSP manufacturer's warranty, upon inspection of the defective item. Any item refused for warranty upon inspection will automatically be returned to the customer. A precise description of the defect must be provided.

To receive the DSP limited warranties listed above, the customer (general public) must follow these steps. DSP will refuse any warranties if these steps are not followed:

- 1.) The original purchaser must fill out the Warranty Card within thirty (30) days of the original purchase and have returned to the address on the card or listed below.
- 2.) The customer must contact DSP for a claim number, call 1-800-265-3377 or www.dsphitches.com.
- 3.) The product in question must have a toe tag clearly marked with a claim number, name, phone number, address, the courier company and waybill number and a copy of the receipt from the original purchase/bill of sale of the end user.
- 4.) The product must be sent PREPAID to DSP's address listed below.
- 5.) DSP's representatives will decide over five (5) working days if the product applies to the limited warranty. If not, DSP's representatives will contact and advise the customer using the information on the claim toe tag from #3.
- 6.) DSP will send back the product COLLECT to the address supplied on the claim toe tag.

Diversified Steel Products Mfg. Ltd.
5645 – 92 Street
Edmonton, Alberta, Canada
T6E 3A4
Phone: 1-800-265-3377



HITCHES

www.dsphitches.com

EST.1961

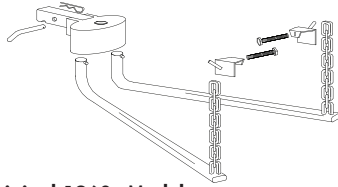

Original 1960s Model
Still seen in use today

1970 - 1999
Weld-on
Bolt-on

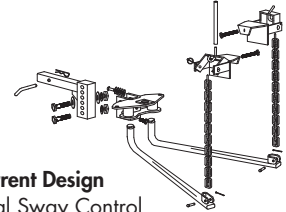
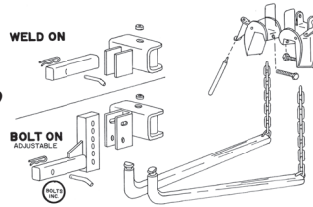

Current Design
Dual Sway Control
Bolt Adjustable
Canada's Last
Domestic Manufacturer

Our Mission

*DSP is dedicated to manufacturing
Towing Accessories and other steel products
of foremost quality, value, and safety.*

Diversified Steel Products Mfg. Ltd. (AB)
"Celebrating 50 Years SeRVing Western Canada"
Edmonton, Alberta, Canada
5645 - 92 Street, T6E 3A4

Ph: 1-780-435-6226
Fax: 1-780-435-6221

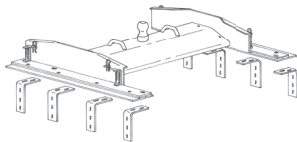

Canada's 1st
Removable Gooseneck Hitch

Toll Free 1 (800) 265-3377

or visit us at

www.dsphitches.com

Email: customersupport@dsphitches.com

Brian Teske blteske@dsphitches.com

Darlene Teske

Katja Teske

Richard Teske

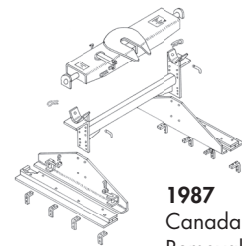

1987
Canada's 1st
Removable
Fifth Wheel

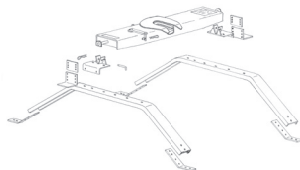

1981 - 1991
Over Fender
Canada's 1st Fifth Wheel

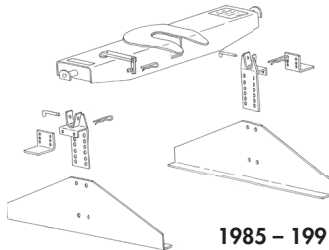

1985 - 1991
Canada's 1st
Between Fender

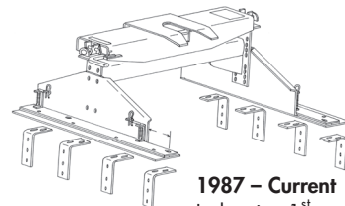

1987 - Current
Industries 1st
Integration Dual
Position Fifth Wheels